



**Axonm L.L.C.
FCC Part 15, Certification Application
AXC550 (Internal), Rev B Transmitter**

**UST Project: 02-0266
September 12, 2002**

MEASUREMENT/TECHNICAL REPORT

COMPANY NAME: **Axon L.L.C.**

MODEL: **AXC550 (Internal), Rev B Transmitter**

FCC ID: **L2VAXC550INT**

DATE: **September 12, 2002**

This report concerns (check one): Original grant X
Class II change _____

Equipment type: **Direct Sequence Spread Spectrum (Modular)**

Deferred grant requested per 47 CFR 0.457(d)(1)(ii)? yes _____ No X

If yes, defer until: _____
date

N.A. agrees to notify the Commission by N.A.
date

of the intended date of announcement of the product so that the grant can be issued on that date.

Report prepared by:

United States Technologies, Inc.
3505 Francis Circle
Alpharetta, GA 30004

Phone Number: (770) 740-0717
Fax Number: (770) 740-1508

TABLE OF CONTENTS

AGENCY AGREEMENT LETTER OF CONFIDENTIALITY

SECTION 1

GENERAL INFORMATION

- 1.1 Product Description
- 1.2 Related Submittal(s)

SECTION 2

TESTS AND MEASUREMENTS

- 2.1 Configuration of Tested EUT
- 2.2 Test Facility
- 2.3 Test Equipment
- 2.4 Modifications
- 2.5 Test Procedure and Results
- 2.6 Antenna Description
- 2.7 Peak Power (Antenna Conducted at Antenna Terminal)
- 2.8 Antenna Conducted Spurious Emissions
- 2.9 Peak Radiated Spurious Emissions
- 2.10 Average Radiated Spurious Emissions
- 2.11 Minimum 6 dB Bandwidth
- 2.12 Power Spectral Density
- 2.13 Power Line Conducted Emissions for Transmitter
- 2.14 Radiated Emissions for Digital Device & Receiver (if Applicable)
- 2.15 Power Line Conducted for Digital Device & Receiver

SECTION 3

LABELING INFORMATION

SECTION 4

BLOCK DIAGRAM(S)/ SCHEMATIC(S)

SECTION 5

PHOTOGRAPHS

SECTION 6

RF EXPOSURE INFORMATION

SECTION 7

USER'S MANUAL

LIST OF FIGURES AND TABLES

- 1) Test Configuration
- 2) Photograph(s) for Spurious and Digital Device Emissions
- 3) Peak Power Output
- 4) Antenna Conducted Spurious Emissions
- 5) Peak Radiated Spurious Emissions
- 6) Average Radiated Spurious Emissions
- 7) Minimum 6 dB Bandwidth
- 8) Power Spectral Density

TABLES

- 1) EUT and Peripherals
- 2) Test Instruments
- 3) Peak Power Output
- 4) Peak Radiated Spurious Emissions
- 5) Average Radiated Spurious Emissions
- 6) Power Spectral Density
- 7) Conducted Emissions Data (Transmitter)
- 8) Radiated Emissions Data (Digital Device)
- 9) Conducted Emissions Data (Digital Device)

SECTION 1

GENERAL INFORMATION

GENERAL INFORMATION

1.1 Product Description

The Equipment Under Test (EUT) is the Axonn L.L.C.'s, Model AXC550 (Internal), Rev B Transmitter. The EUT utilizes direct sequence spread spectrum technology for communication on the following channels: 905.58, 908.58, 911.58, 914.58, 917.58, 920.58, 923.58, and 926.58 MHz. The transmitter modulation incorporates BPSK modulation for generating a direct-sequence, spread spectrum carrier. The data modulation for the device utilizes either OOK or BPSK data modulation techniques as selectable by the user application.

The EUT is identical to a previously approved version (which was modularly approved under FCC ID: L2VAX550) with the exception that one of the regulators has been removed from the transmitter board and is to be implemented by the outside host devices. This application is being submitted in order to approve the EUT as a stand-alone limited modular approval (limited for use within Axonn L.L.C. products only) since Axonn will maintain control of the final products and ensure that the transmitter module is fully supplied with the proper external regulated voltage. Please refer to the following letter from Axonn L.L.C.



L.L.C

2021 Lakeshore Dr. Suite 500 □ New Orleans, Louisiana 70122 □ (504) 282-8119

July 2, 2002

Federal Communication Commission
Equipment Authorization Division
7435 Oakland mills Road
Columbia, MD 21046

Dear Sir or Madam

This letter requests that the attached filing (FCC ID L2VAXC550INT) and be submitted for Limited Modular Approval. In reference to FCC Public Notice DA 00-1407, the following is stated:

1. All components except the antennas are enclosed by the metal shielding and ground plane.
2. All data inputs are buffered. The AXC550INT provides buffering for all of it's external inputs and outputs obtainable by the end user through connectors J1 and J2. No direct connection between any of the AXC550 INT RF circuitry is provided without on-board buffering. The inputs and outputs to the AXC550INT are digital, with the exception of the +5 Volt, DC supply input. Through specification and interaction with the end user this +5 volt input is closely controlled. The digital inputs to the AXC550 are buffered through the AX602 transmit controller ASIC (UXXX), the TIP processor (UXX), or by dedicated circuitry intended for that purpose. Please refer to the theory of operations document that is supplied with this report for further discussion of these functions
3. The device was submitted as a stand-alone unit for testing.
4. Limited – Modular Approval conditions:

Axon is launching a product family that incorporates radio products that have previously received modular approval from the FCC. The new Axonn product number is AXC550INT, which is being combined with a product family marketed under an Axonn part number of AX16xxI where the xx is replaced with numerals denoting specific hardware configurations not impacting radio operation.

The embedded radio to be used in this product family has been previously evaluated as modular compliant and assigned FCC ID of L2VAXC550. A slight power supply modification is necessary to accommodate battery operation in the AX16xxI product

CONFIDENTIAL
TO BE USED ONLY FOR THE PURPOSE FOR WHICH IT IS SUBMITTED. ALL RIGHTS RESERVED TO AXONN CORPORATION. REPRODUCTION WITHOUT PRIOR WRITTEN CONSENT IS PROHIBITED.

family making it necessary to re-evaluate the overall unit for FCC compliance in light of Public Notice (DA 00-1407, Released: June 26, 2000) item 3 which states:

3. The modular transmitter must have its own power supply regulation. This is intended to ensure that the module will comply with Part 15 requirements regardless of the design of the power supplying circuitry in the device into which the module is installed.

Our intention is to re-certify the radio operation of the unit seeking limited-modular approval. It is the intention of this letter to fully explain the justification for this action.

Circuit Change:

The radio module L2VAXC550 incorporates a linear regulator as the power conditioning circuit. Provisions were made on the copper of the existing device to remove this regulator and bypass it with a wire jumper. This forces the line regulation of the radio device to the outside host and negates the modular approval of the device.

The L2VAXC550INT will be combined with the L2VAX16xxI product family that takes the identical regulator removed from the radio transceiver and locates it with isolation switches on the host carrier board. This is to provide for complete power shutdown of the device to preserve battery life. While in operation mode, the isolation switches are closed and the regulator operates exactly as designed into the radio product.

There exists no other load on the regulator. The regulator on the host board provides power only for the radio device providing an electrical equivalence to the original configuration.

Failsafe operation of the radio is assured through lock detect circuitry in the radio product. If power fails on the device or on the host carrier board, the radio will disable the transmit section thus protecting the device from transmitting outside the band of allocation.

Additionally, testing of the configuration indicates there is no impact to output power either in band or out of band and to all measurable means any difference in operation of the radio device as a whole.

Intent and Action:

It is therefore our desire to seek limited-modular approval of the L2VAXC550INT and device as provided for in the Public Notice. This device will only be used with Axonn products.

Sincerely,
[Gary Naden](#)

Gary Naden
V.P. Engineering
Axonn LLC

1.2 Related Submittal(s)/Grant(s)

The EUT will be used with part of a system to send/receive data. The transmitter presented in this report will be used with similar transceivers or previously approved receivers.

The EUT is subject to the following authorizations:

- a) Certification as a transmitter (limited modular approval)

The information contained in this report is presented for the certification authorization for the EUT.

SECTION 2

TESTS AND MEASUREMENTS

TEST AND MEASUREMENTS

2.1 Configuration of Tested System

The sample was tested per ANSI C63.4, Methods of Measurement from Low-Voltage Electrical and Electronic Equipment in the Range of 9 kHz to 40 GHz (1992). Conducted and radiated emissions data were taken with the test receiver or spectrum analyzer's resolution bandwidth adjusted to 9 kHz and 120 kHz, respectively. All measurements are peak unless stated otherwise. The video filter associated with the spectrum analyzer was off throughout the evaluation process. Interconnecting cables were manipulated as necessary to maximize emissions. Interconnecting cables were manipulated as necessary to maximize emissions. A block diagram of the tested system is shown in Figure 1. Test configuration photographs for spurious and fundamental emissions are shown in Figure 2.

The sample used for testing was received by U.S. Technologies on July 30, 2002 in good condition.

2.2 Test Facility

Testing was performed at US Tech's measurement facility at 3505 Francis Circle, Alpharetta, GA. This site has been fully described and submitted to the FCC, and accepted in their letter marked 31040/SIT. Additionally this site has also been fully described and submitted to Industry Canada (IC), and has been approved under file number IC2982.

2.3 Test Equipment

Table 2 describes test equipment used to evaluate this product.

2.4 Modifications

No modifications were made by US Tech, to bring the EUT into compliance with FCC Part 15 limits for the transmitter portion of the EUT.

FIGURE 1
TEST CONFIGURATION

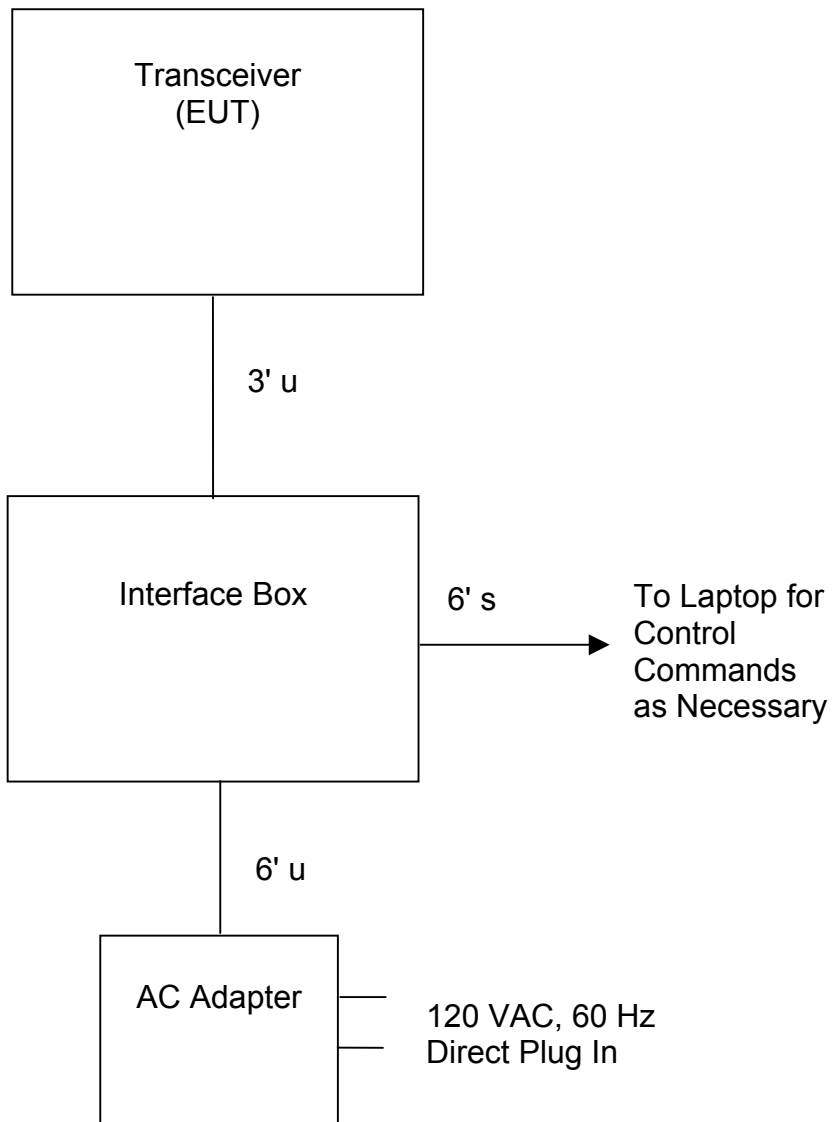

Test Date: July 30 – July 31, 2002
UST Project: 02-0266
Customer: Axonn L.L.C.
Model: AXC550 (Internal), Rev B Transmitter

FIGURE 2a

Photograph(s) for Spurious Emissions (Front)

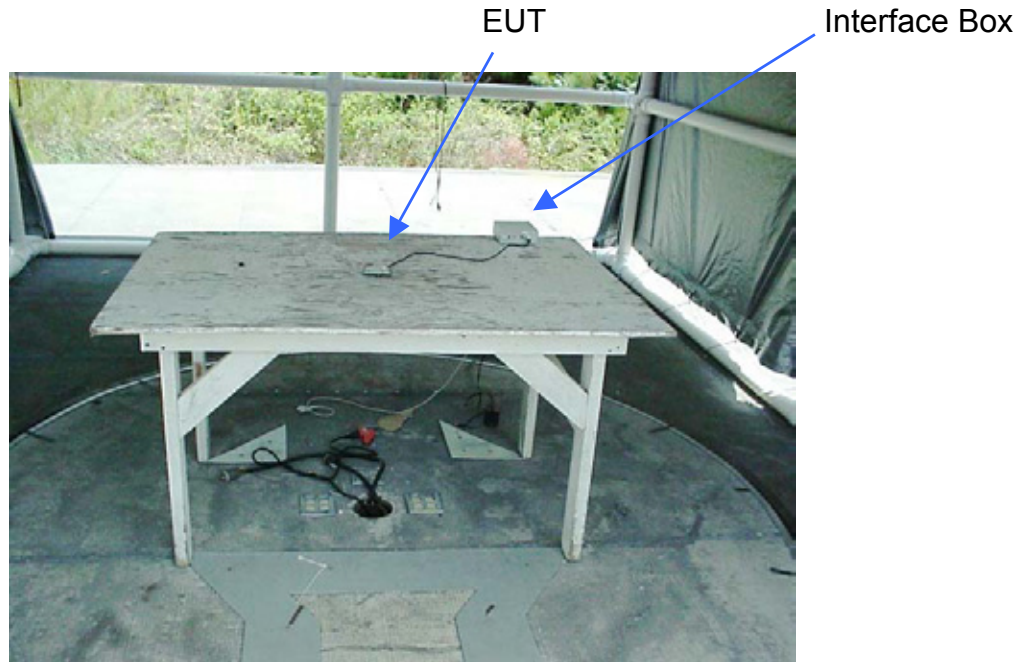

Test Date: July 30 – July 31, 2002
UST Project: 02-0266
Customer: Axonn L.L.C.
Model: AXC550 (Internal), Rev B Transmitter

FIGURE 2b

Photograph(s) for Spurious Emissions (Back)

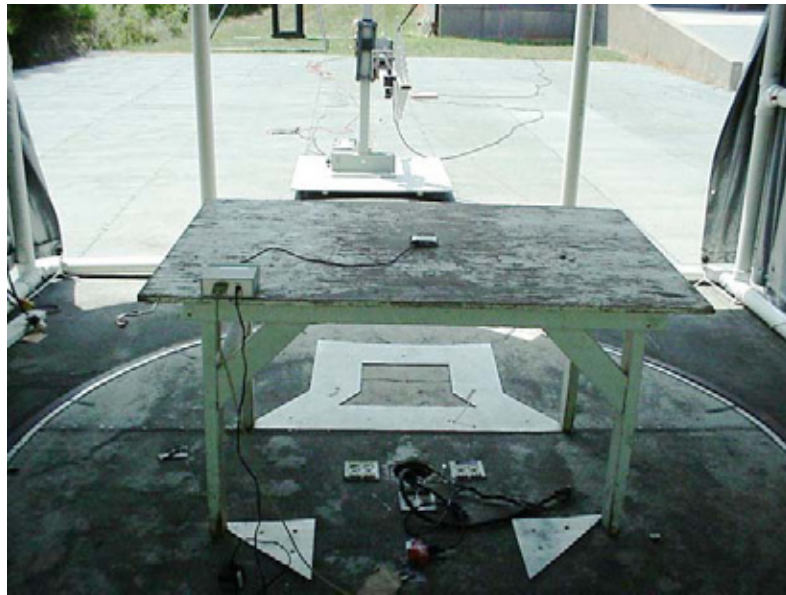

Test Date: July 30 – July 31, 2002
UST Project: 02-0266
Customer: Axonn L.L.C.
Model: AXC550 (Internal), Rev B Transmitter

FIGURE 2c

Photograph(s) for Digital Device/Receiver Emissions (Front)



Test Date: July 30 – July 31, 2002
UST Project: 02-0266
Customer: Axonn L.L.C.
Model: AXC550 (Internal), Rev B Transmitter

FIGURE 2d

Photograph(s) for Digital Device/Receiver Emissions (Back)

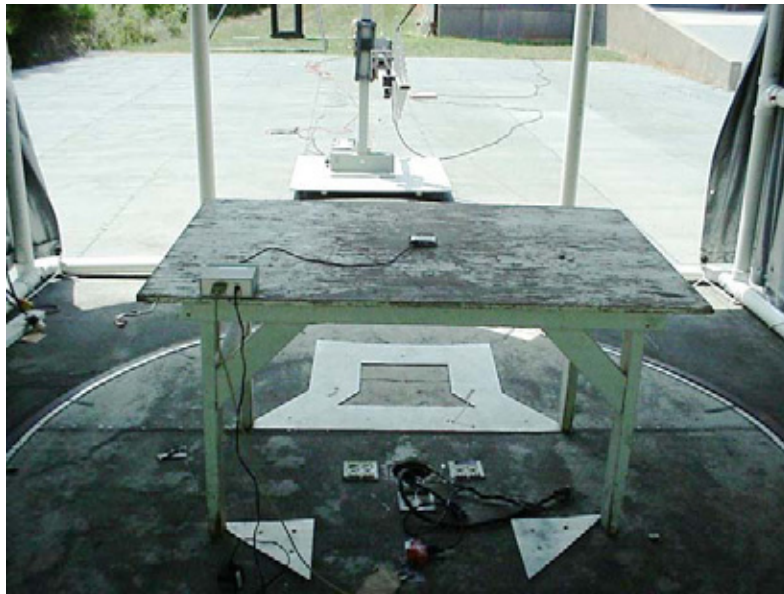

Test Date: July 30 – July 31, 2002
UST Project: 02-0266
Customer: Axonn L.L.C.
Model: AXC550 (Internal), Rev B Transmitter

FIGURE 2e

Photograph(s) for Conducted Emissions

Transmitter



Test Date: July 30 – July 31, 2002
UST Project: 02-0266
Customer: Axonn L.L.C.
Model: AXC550 (Internal), Rev B Transmitter

FIGURE 2f

Photograph(s) for Conducted Emissions

Receiver



TABLE 1**EUT and Peripherals**

PERIPHERAL MANUFACTURER	MODEL NUMBER	SERIAL NUMBER	FCC ID:	CABLES P/D
Modular TX Board Axonn L.L.C.	AXC550 (Internal), Rev B	None	L2VAXC550INT (pending)	3'u
Interface Box Axonn L.L.C.	None	None	None	6's
AC Adapter View Port Technology, Inc.	DV-91A	None	None	6' u

**TABLE 2
TEST INSTRUMENTS**

TYPE	MANUFACTURER	MODEL	SN.
SPECTRUM ANALYZER	HEWLETT-PACKARD	8593E	3205A00124
SPECTRUM ANALYZER	HEWLETT-PACKARD	8558B	2332A09900
S A DISPLAY	HEWLETT-PACKARD	853A	2404A02387
COMB GENERATOR	HEWLETT-PACKARD	8406A	1632A01519
RF PREAMP	HEWLETT-PACKARD	8447D	1937A03355
RF PREAMP	HEWLETT-PACKARD	8449B	3008A00480
HORN ANTENNA	EMCO	3115	3723
BICONICAL ANTENNA	EMCO	3110	9307-1431
LOG PERIODIC ANTENNA	EMCO	3146	9110-3600
BILOG	CHASE	CBL6112A	2238
LISN	SOLAR ELE.	8028	910494
LISN	SOLAR ELE.	8028	910495

2.6 Antenna Description (Paragraph 15.203)

An intentional radiator shall be designed to ensure that no antenna other than that furnished by the responsible party shall be used with the device. The use of a permanently attached antenna or of an antenna that uses a unique coupling to the intentional radiator shall be considered sufficient to comply with the provisions of this section.

The Axonn L.L.C. Model AXC550 (Internal), Rev B Transmitter incorporates an internal (integrated) antenna only. The EUT contains 1 transmit antenna and 2 receive antennas. The manufacture has performed testing on the antenna and considers it to have a 0 dBi gain antenna. A different model certified under a separate FCC ID incorporates a connector and external antennas.

2.7 Peak Power Within the Band 902 - 928 MHz per FCC Section 15.247(b)

Peak power within the band 902 - 928 MHz has been measured with a spectrum analyzer. Since the EUT incorporated an integrated antenna, this measurement was made on a OAT's site. The measurement was made with a spectrum analyzer using a peak detector with the $VBW \geq RBW \geq 6$ dB bandwidth and the EIRP from the EUT was calculated. Field strength of the peak fundamental emissions is shown in Table 3 and Figure 3.

The EUT did not incorporate any antennas of directional gain greater than 6 dBi, therefore the output power has not been reduced as required by 15.247(b)(3).

**TABLE 3
PEAK POWER OUTPUT**

Test Date: July 30, 2002
UST Project: 02-0266
Customer: Axonn L.L.C.
Model: AXC550 (Internal), Rev B Transmitter

Frequency (MHz)	Receiver Reading (dBm) @3m	Correction Factor (dB)	Corrected Reading (V/m) @3m	Measured Power (Watt)	FCC Limit (Watt)
905.58	-20.9	31.0	0.716143	0.154	1.0
914.58	-20.4	30.8	0.741310	0.165	1.0
926.58	-21.7	31.3	0.676083	0.137	1.0

Transmitters peak power calculated using:

$$P (W) = \frac{(E*d)^2}{30*G}$$

where d = 3 meters, E = corrected measured field strength in V/m, and G = numeric gain of transmitting antenna (1.0 for 0 dBi).

SAMPLE CALCULATIONS:

CORRECTED READING @ 3m (V/m) = Antilog ((-20.9 + 31.0 + 107)/20)* 10⁻⁶ = 0.716143
CONVERSION FROM dBm TO dBuV = 107 dB

Tester
Signature: David P. Blethen **Name:** David Blethen

Figure 3a
Peak Power per FCC Section 15.247(b) - low

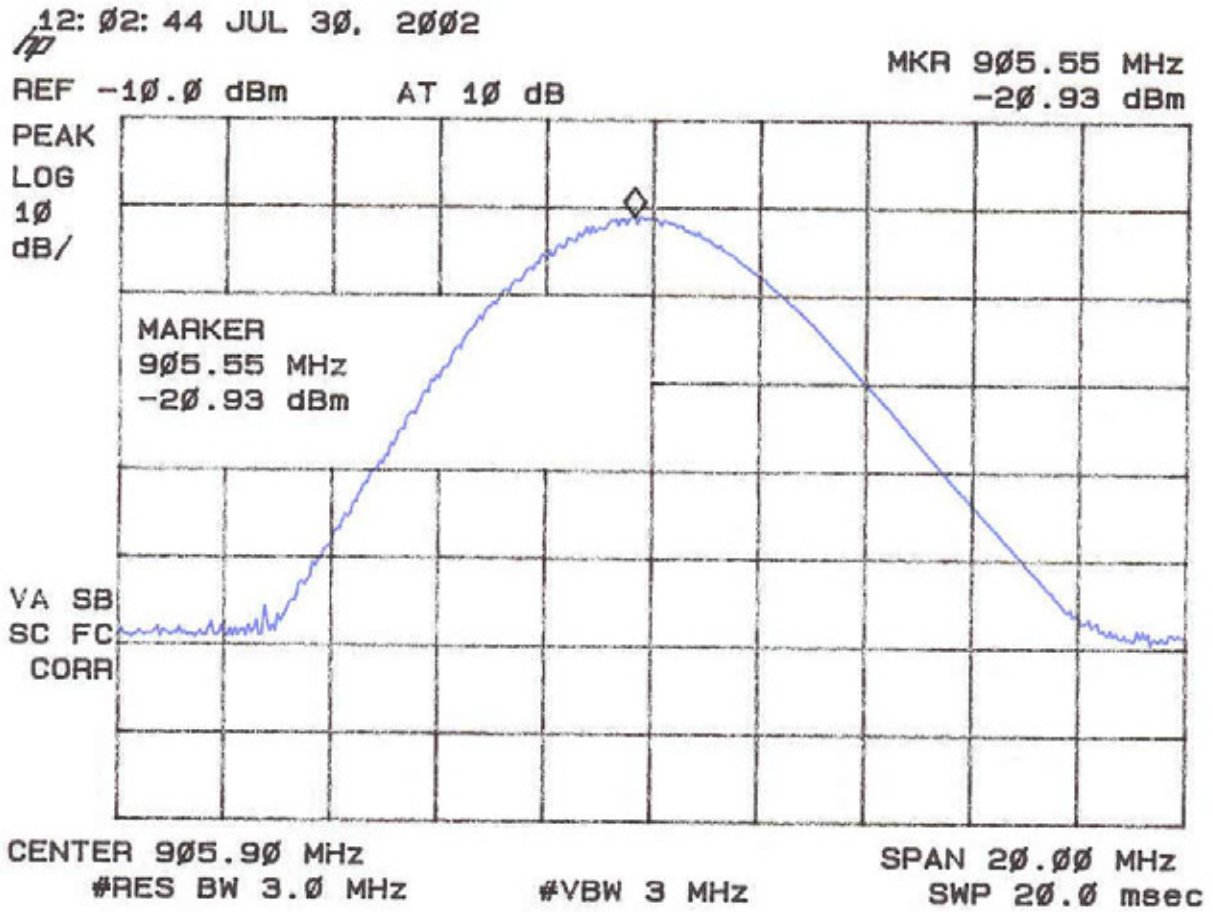

Figure 3b
Peak Power per FCC Section 15.247(b) - mid

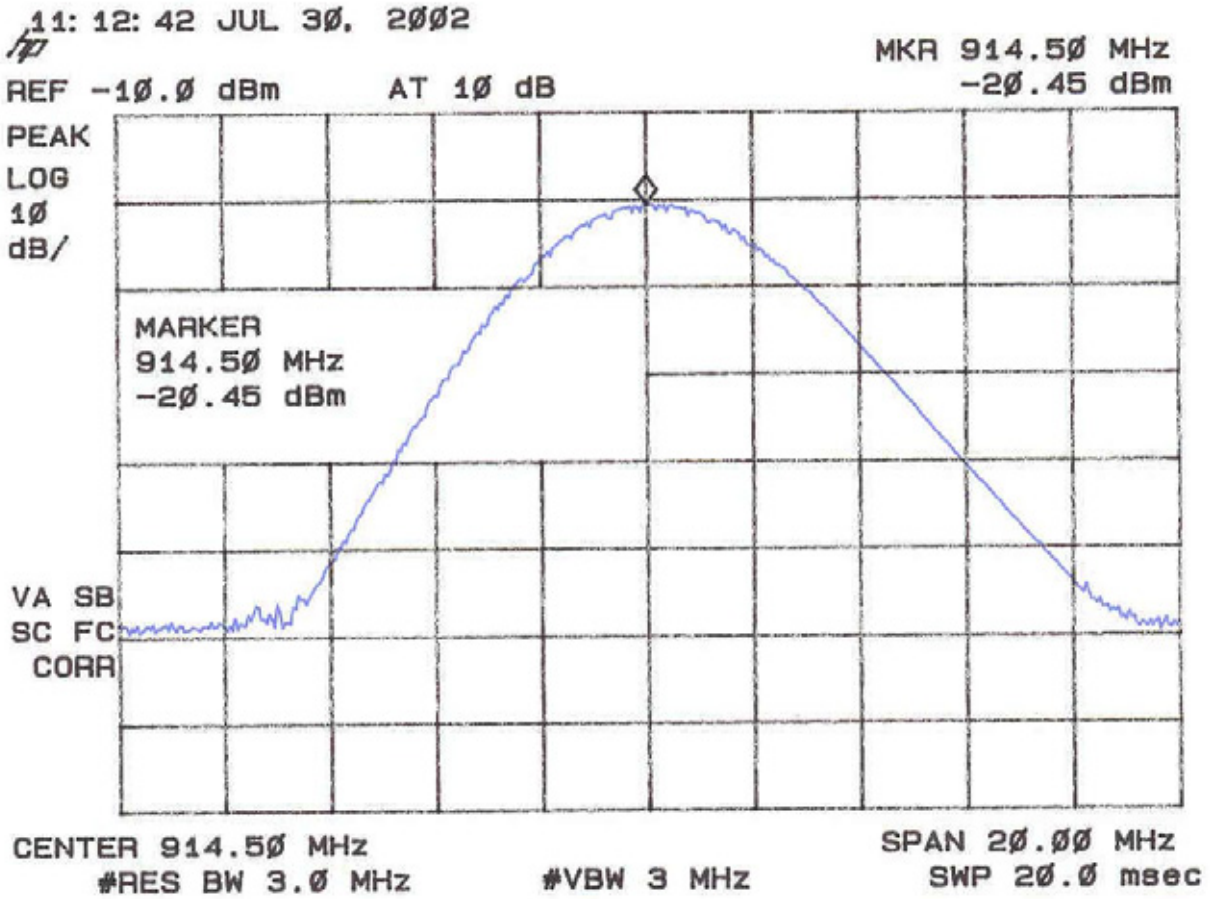
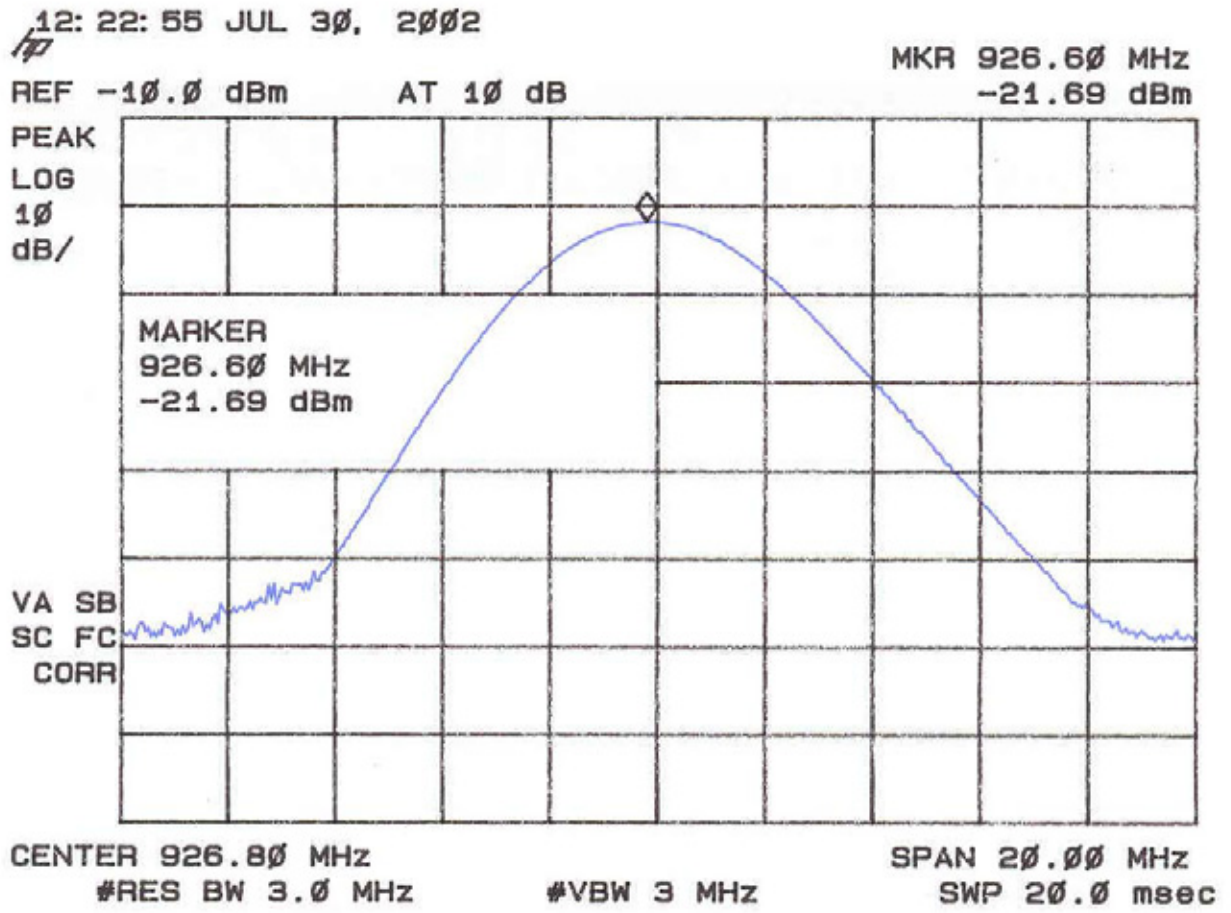

Figure 3c
Peak Power per FCC Section 15.247(b) - high



2.8 Antenna Conducted Spurious Emission in the Frequency Range 30 - 10000 MHz (FCC Section 15.247(c))

Since the EUT has an integrated antenna only, Antenna Conducted Spurious Emissions have been deemed not necessary.

2.9 Peak Radiated Spurious Emission in the Frequency Range 30 -10000 MHz (FCC Section 15.247(c))

A preliminary scan was performed on the EUT to determine frequencies that were caused by the transmitter portion of the product. Significant emissions that fell within restricted bands were then measured on an OAT's site. Radiated measurements below 1 GHz were tested with a RBW = 120 kHz. Radiated measurements above 1 GHz were measured using a RBW = VBW = 1 MHz. The results of peak radiated spurious emissions falling within restricted bands are given in Table 4a through Table 4c and Figure 5a-5k.

Emissions that did not fall within a restricted band were measured using a 100 kHz RBW and compared to the fundamental at 100 kHz to ensure that they meet with the 20 dBc requirement specified by 15.247.

Figure 5a
Peak Radiated Spurious Emission 15.247(c) - Low

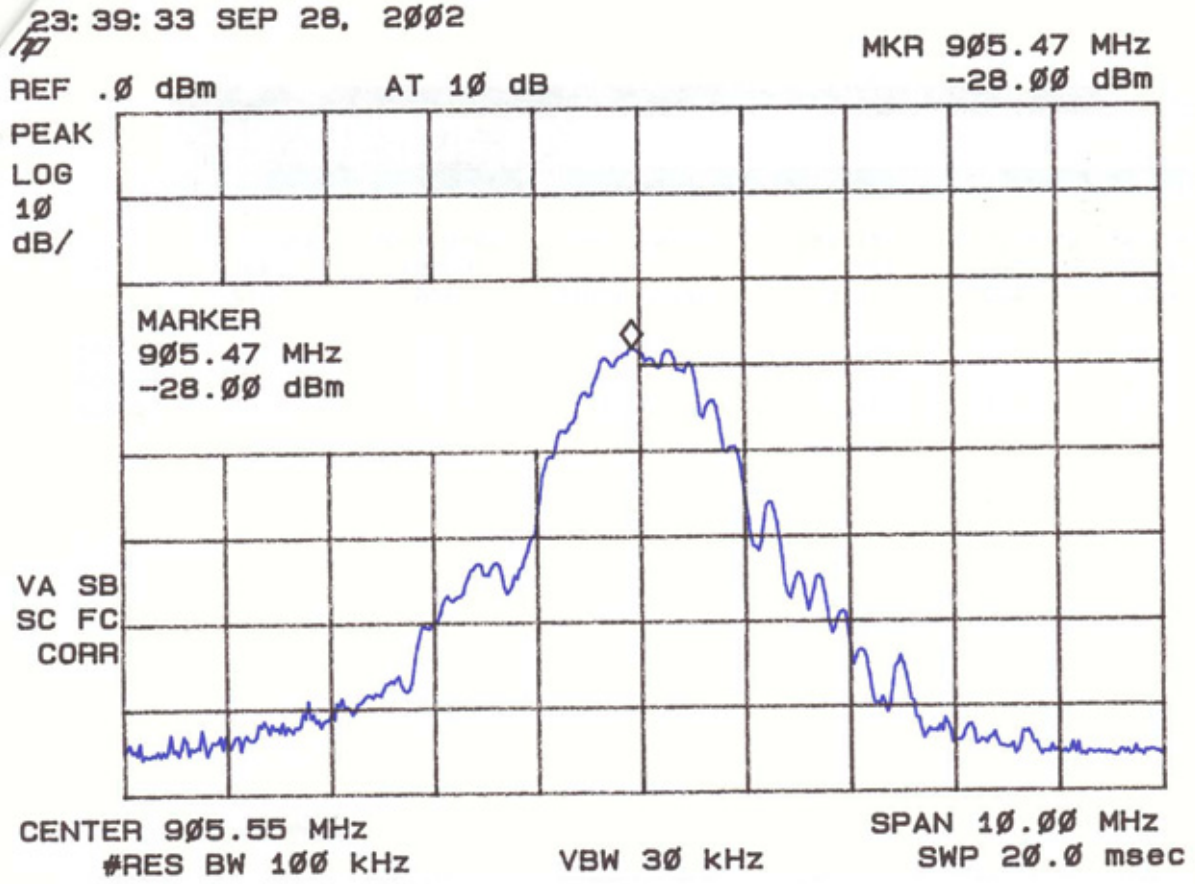

Figure 5b
Peak Radiated Spurious Emission 15.247(c) - Low

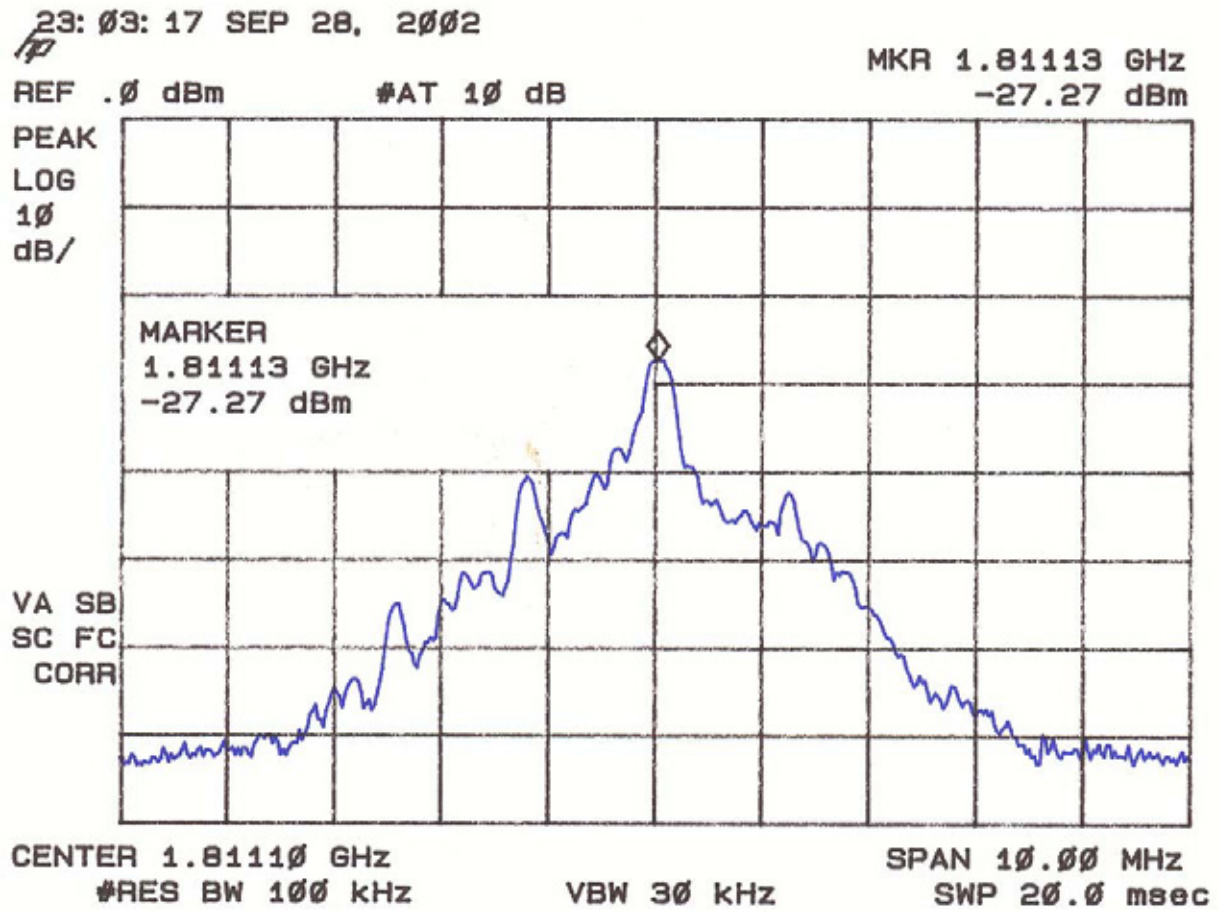

Figure 5c
Peak Radiated Spurious Emission 15.247(c) - Low

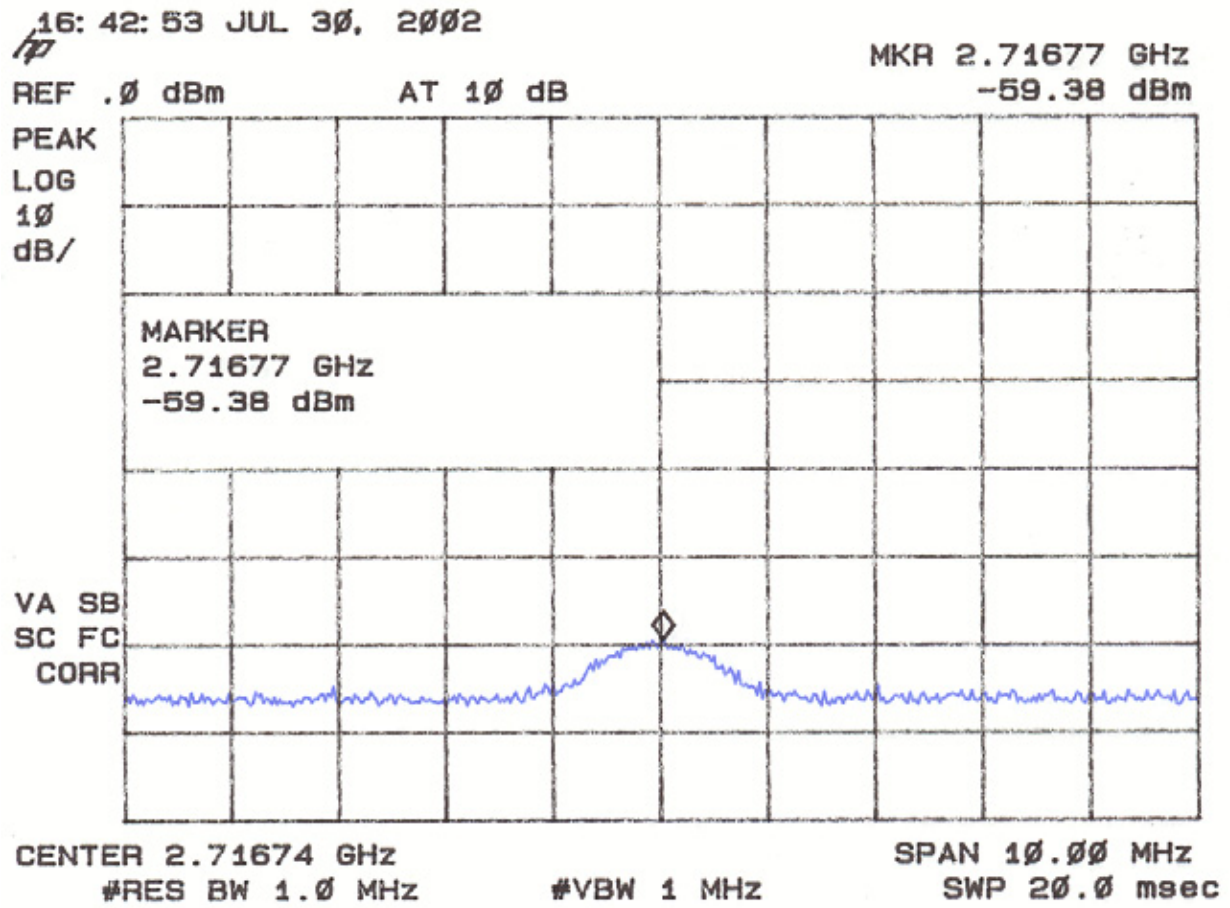

Figure 5d
Peak Radiated Spurious Emission 15.247(c) - Mid

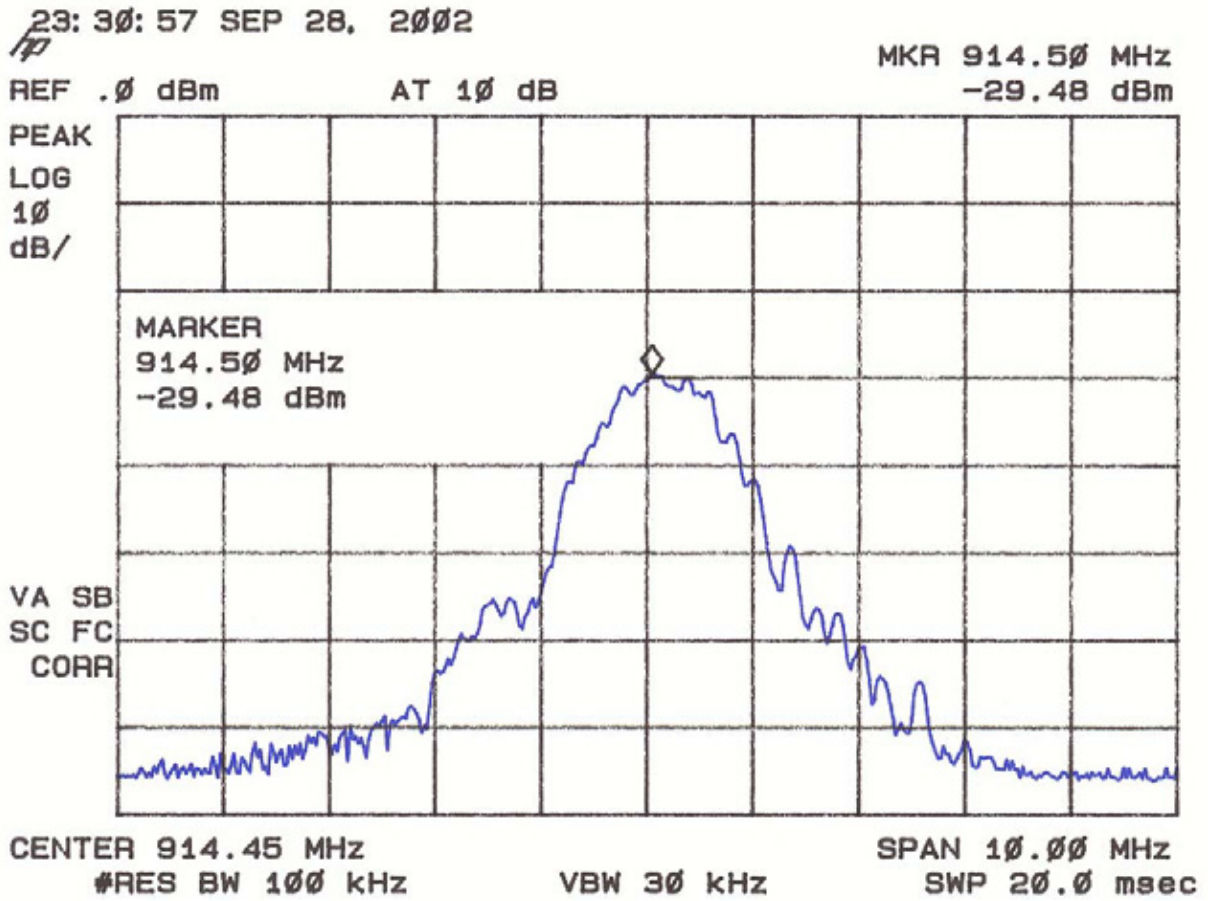

Figure 5e
Peak Radiated Spurious Emission 15.247(c) - Mid

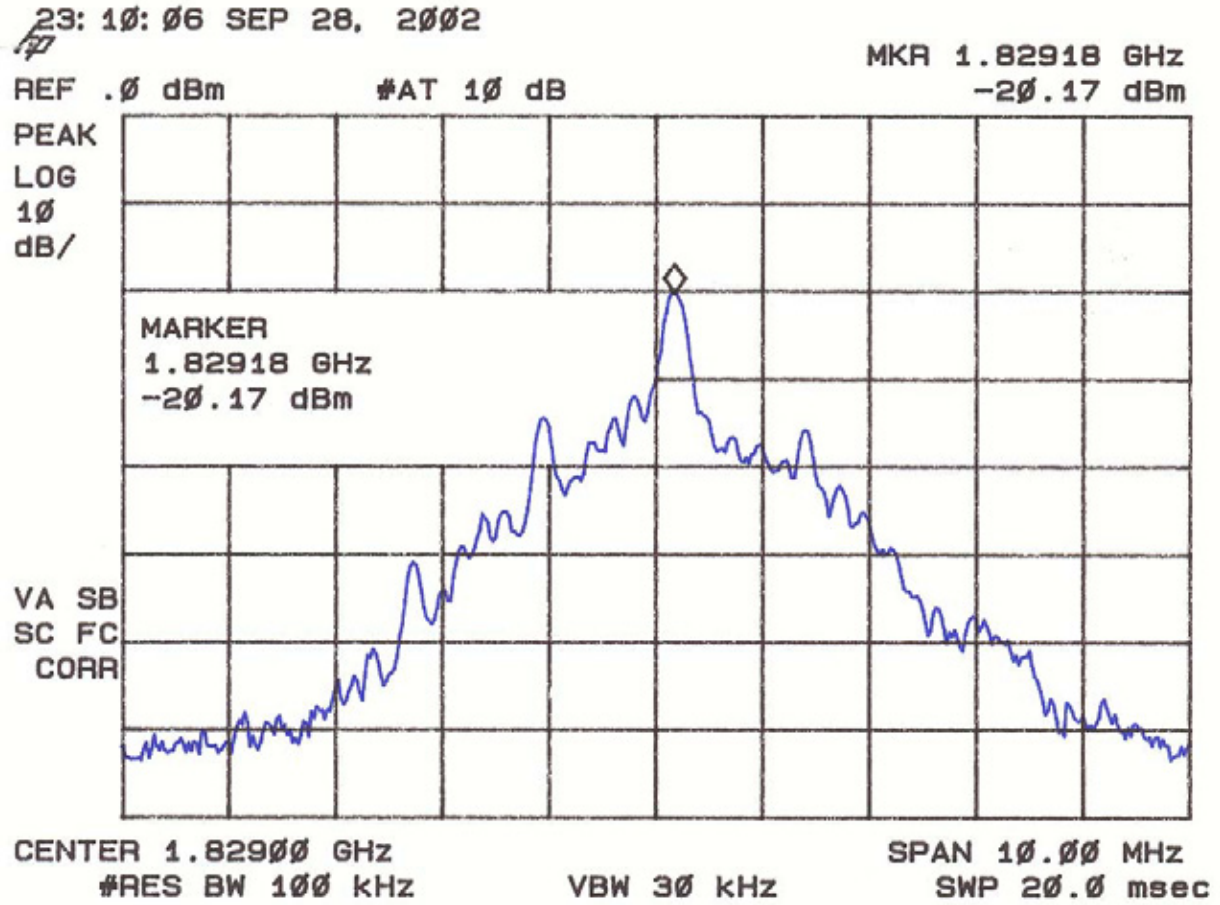

Figure 5f
Peak Radiated Spurious Emission 15.247(c) - Mid

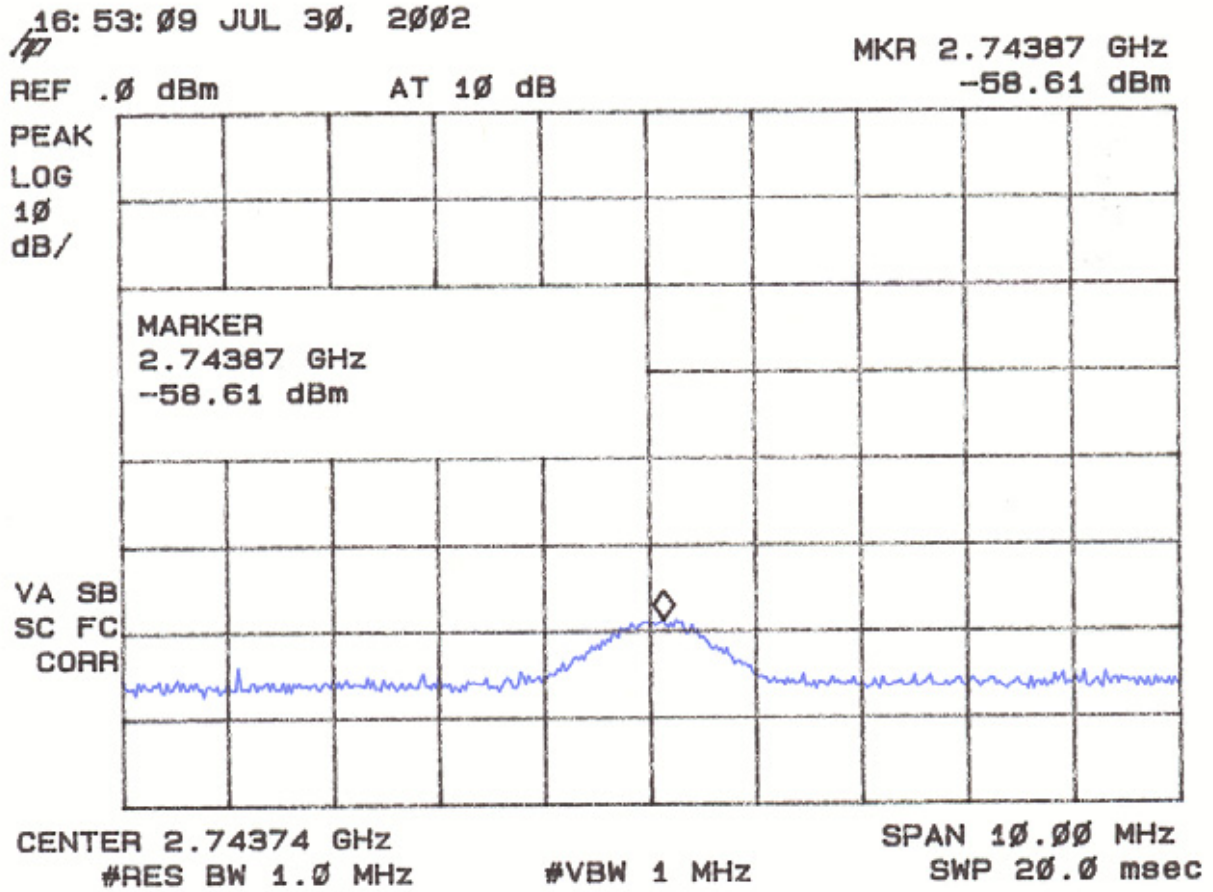

Figure 5g
Peak Radiated Spurious Emission 15.247(c) - Mid

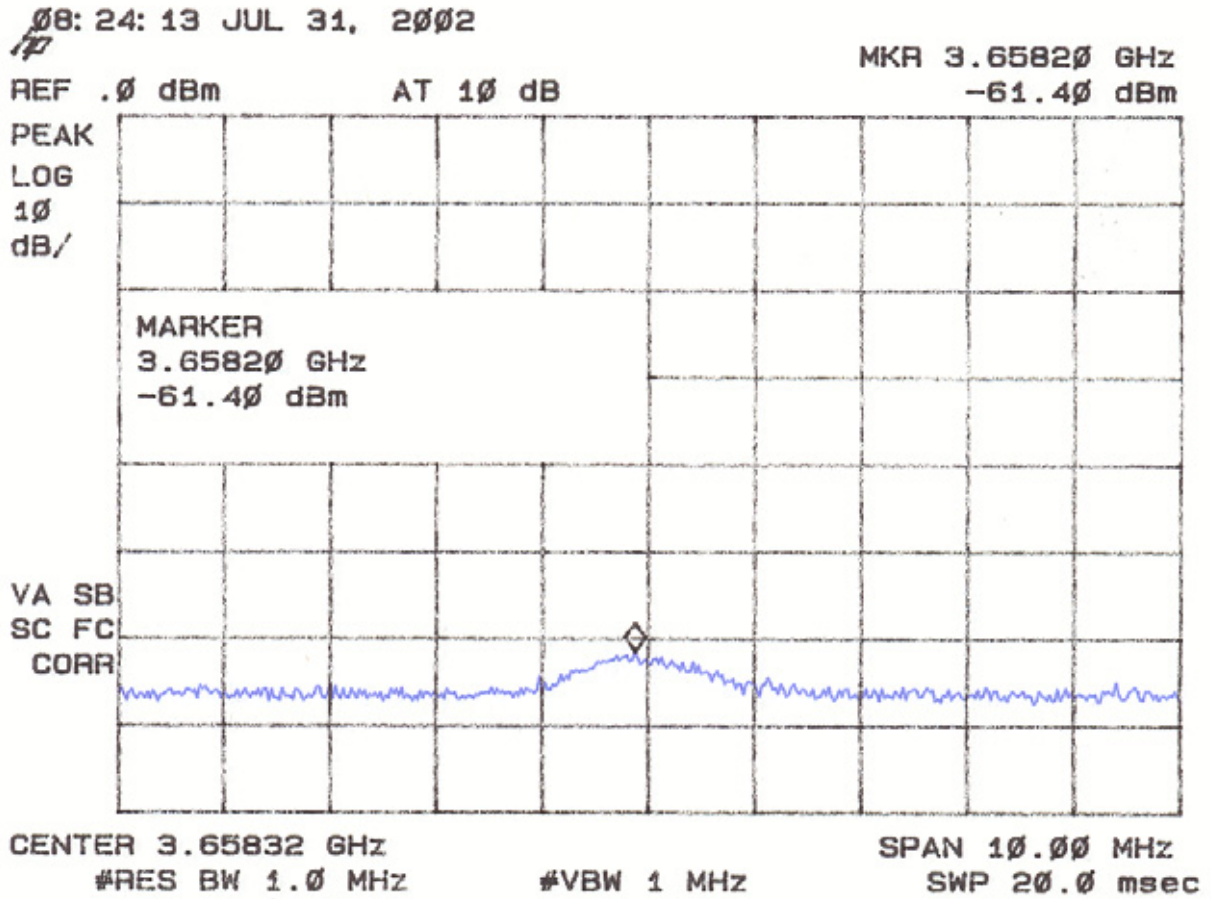

Figure 5h
Peak Radiated Spurious Emission 15.247(c) - High

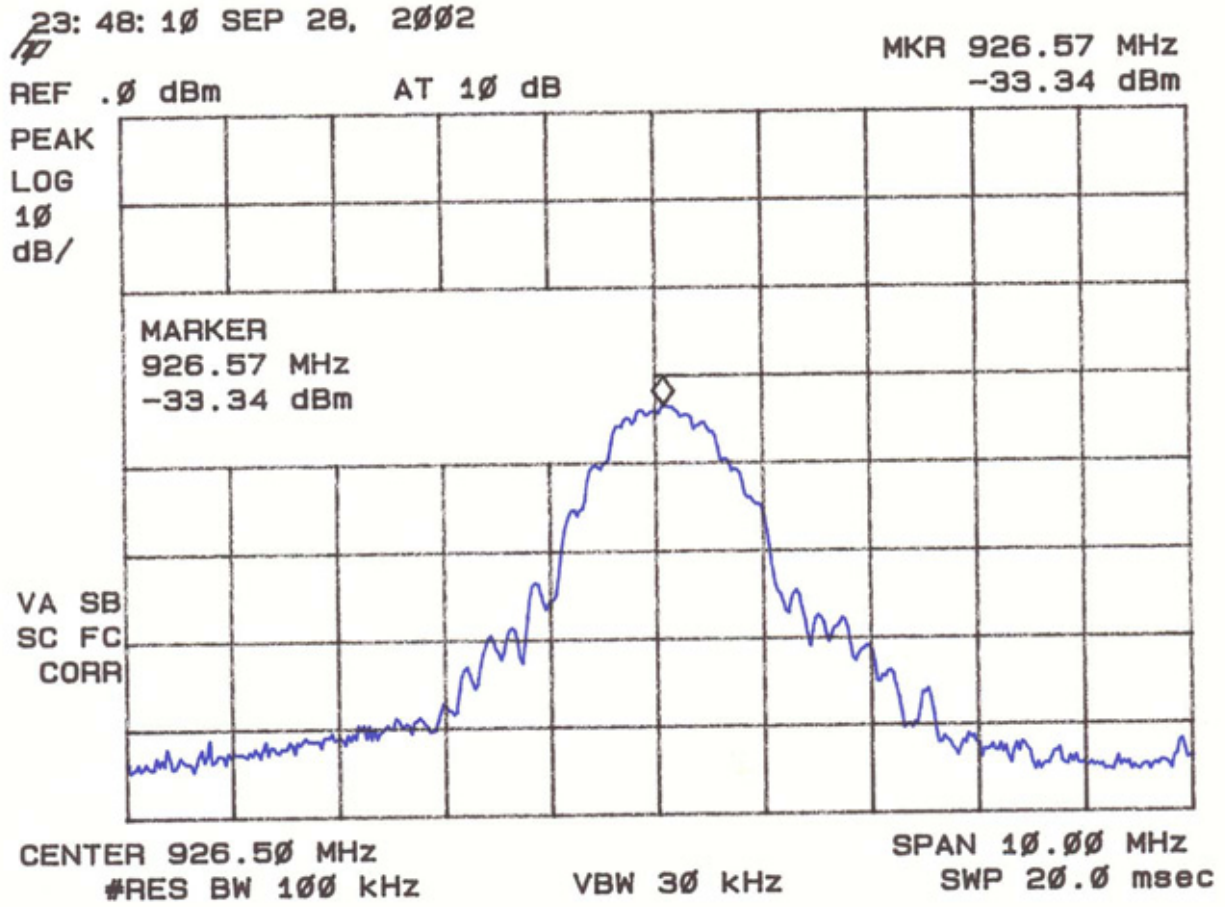

Figure 5i
Peak Radiated Spurious Emission 15.247(c) - High

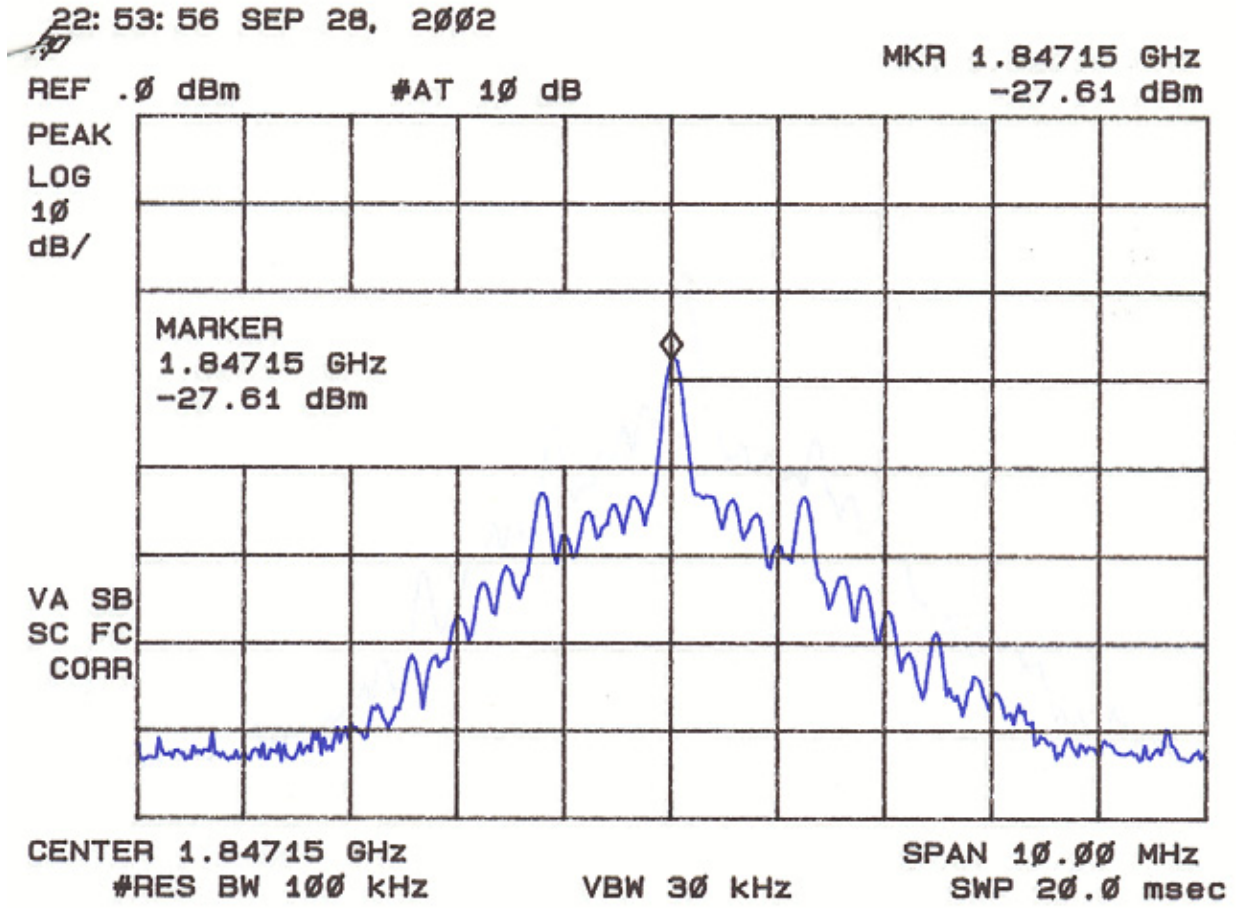

Figure 5j
Peak Radiated Spurious Emission 15.247(c) - High

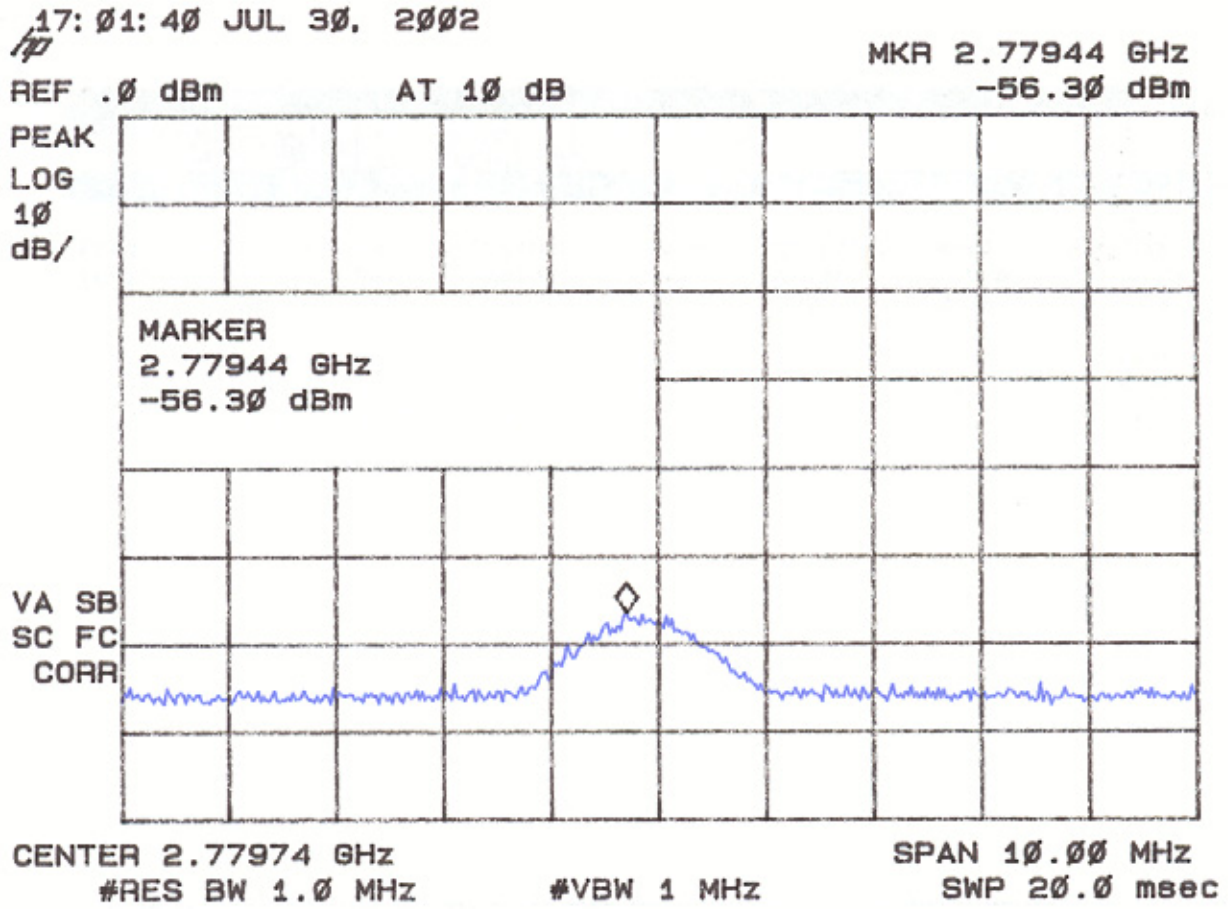

Figure 5k
Peak Radiated Spurious Emission 15.247(c) - High

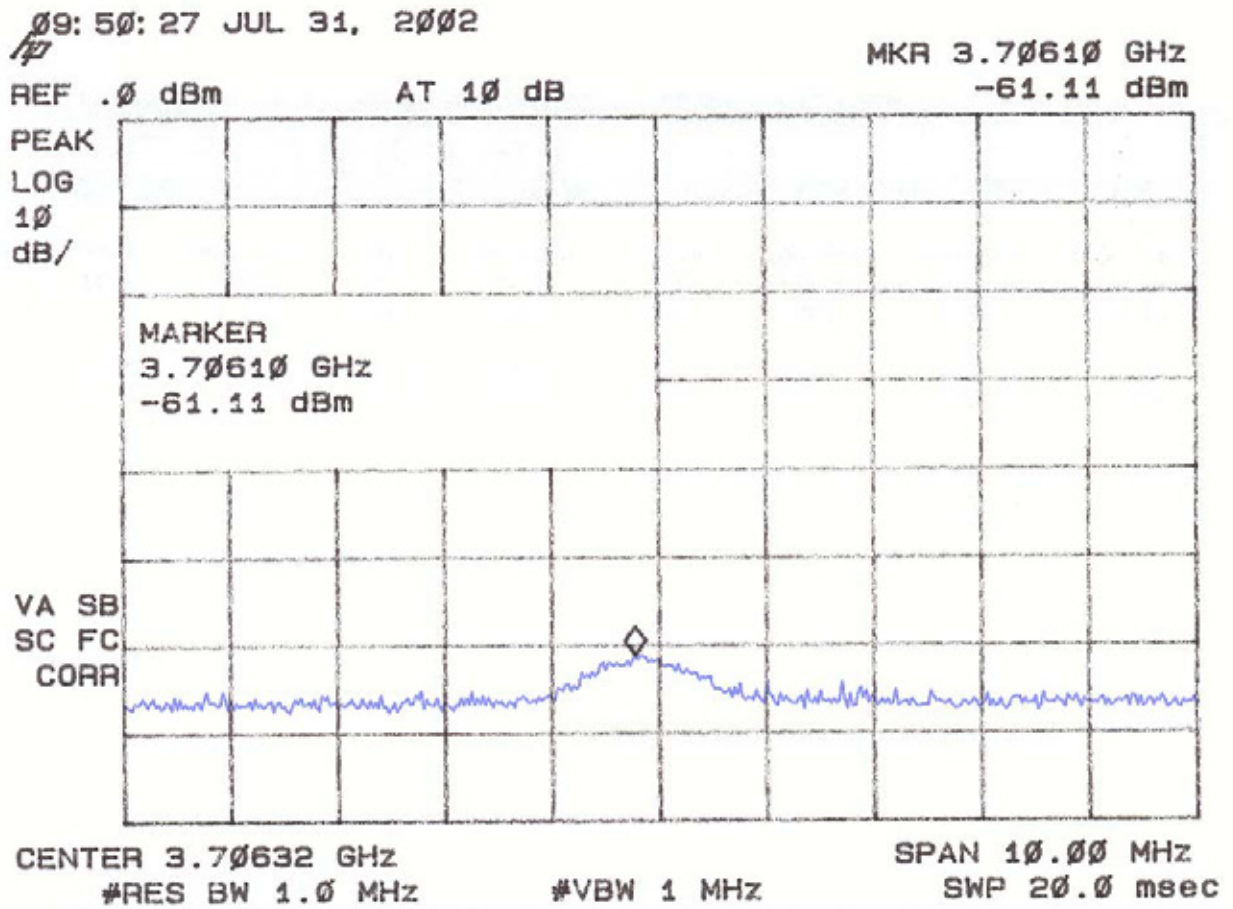

TABLE 4a. PEAK RADIATED SPURIOUS EMISSIONS

Test Date: July 30 & July 31, 2002
UST Project: 02-0266
Customer: Axonn L.L.C.
Product: AXC550 (Internal), Rev B Transmitter

Peak Measurements > 1GHz (Low)

FREQ. (GHz)	TEST DATA* (dBm) @ 3m	AMP GAIN (dB)	ANT. FACTOR (dB)	CABLE LOSS (dB)	RESULTS (uV/m) @ 3m	FCC LIMITS (uV/m) @ 3m
905.5	-28.0	-	29.1 (AF+CL)	-	252,730	-
1.811	-27.2	34.5	28.5	3.0	6849.7 (31.3 dBc)	>20 dBc
2.716	-58.4	34.2	30.7	3.8	278.6	5000.0

* = Data above 1 GHz adjusted by + 1 dB for high pass filter

SAMPLE CALCULATION:

RESULTS (uV/m @ 3m) = Antilog ((-58.4 - 34.2 + 30.7 + 3.8 + 107)/20) = 278.6

CONVERSION FROM dBm TO dBuV = 107 dB

Tester

Signature: David P. Blethen Name: David Blethen

TABLE 4b. PEAK RADIATED SPURIOUS EMISSIONS

Test Date: July 30 & July 31, 2002
UST Project: 02-0266
Customer: Axonn L.L.C.
Product: AXC550 (Internal), Rev B Transmitter

Peak Measurements > 1GHz (Mid)

FREQ. (GHz)	TEST DATA* (dBm) @ 3m	AMP GAIN (dB)	ANT. FACTOR (dB)	CABLE LOSS (dB)	RESULTS (uV/m) @ 3m	FCC LIMITS (uV/m) @ 3m
914.5	-29.5	-	29.3 (AF+CL)	-	219,432	-
1.829	-20.2	34.5	28.6	3.0	15,755.9 (22.9 dBc)	>20 dBc
2.743	-57.6	34.2	30.8	3.8	309.0	5000.0
3.658	-60.4	33.8	33.2	5.0	354.8	5000.0

* = Data above 1 GHz adjusted by + 1 dB for high pass filter

SAMPLE CALCULATION:

RESULTS (uV/m @ 3m) = Antilog ((-57.6 - 34.2 + 30.8 + 3.8 + 107)/20) = 309.0

CONVERSION FROM dBm TO dBuV = 107 dB

Tester

Signature: David P. Blethen

Name: David Blethen

TABLE 4c. PEAK RADIATED SPURIOUS EMISSIONS

Test Date: July 30 & July 31, 2002
 UST Project: 02-0266
 Customer: Axonn L.L.C.
 Product: AXC550 (Internal), Rev B Transmitter

Peak Measurements > 1GHz (High)

FREQ. (GHz)	TEST DATA* (dBm) @ 3m	AMP GAIN (dB)	ANT. FACTOR (dB)	CABLE LOSS (dB)	RESULTS (uV/m) @ 3m	FCC LIMITS (uV/m) @ 3m
926.6	-33.3	-	29.6 (AF+CL)	-	145,757	-
1.847	-27.6	34.5	28.7	3.0	6794.9 (26.6 dBc)	>20 dBc
2.779	-55.3	34.1	30.8	3.9	412.1	5000.0
3.706	-60.1	33.7	33.4	5.0	380.2	5000.0

* = Data above 1 GHz adjusted by + 1 dB for high pass filter

SAMPLE CALCULATION:

RESULTS (uV/m @ 3m) = Antilog $((-55.3 - 34.1 + 30.8 + 3.9 + 107)/20)$ = 412.1

CONVERSION FROM dBm TO dBuV = 107 dB

Tester

Signature: David P. Blethen Name: David Blethen

2.10 Average Spurious Emission in the Frequency Range 30 - 10000 MHz (FCC Section 15.247(c))

The results of average radiated spurious emissions falling within restricted bands are given in Table 5a through Table 5c and Figure 6a through Figure 6f.

Duty Cycle Correction During 100 msec:

Duty cycle correction has not been applied to the measurement data.

Figure 6a
Average Radiated Spurious Emission 15.247(c) - Low

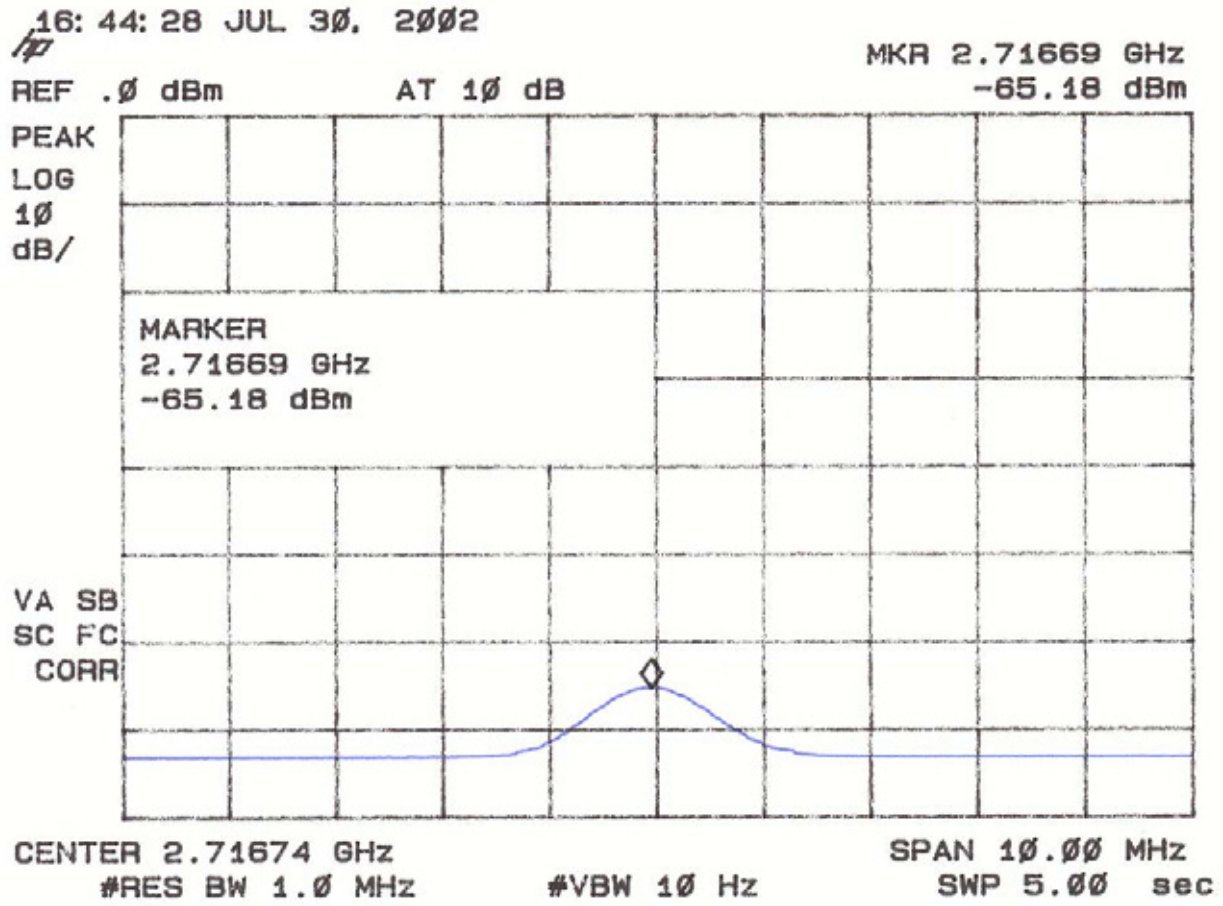

Figure 6b
Average Radiated Spurious Emission 15.247(c) - Mid

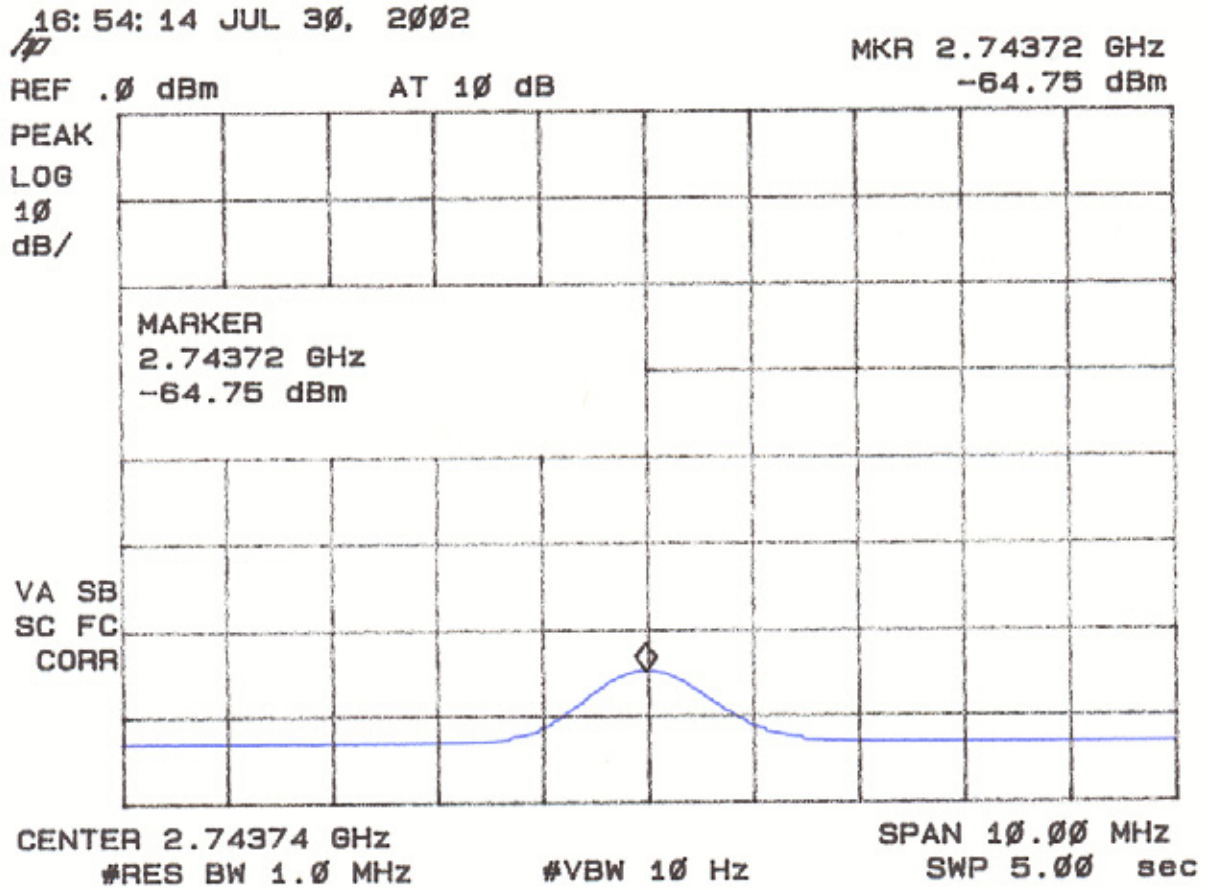

Figure 6c
Average Radiated Spurious Emission 15.247(c) - Mid

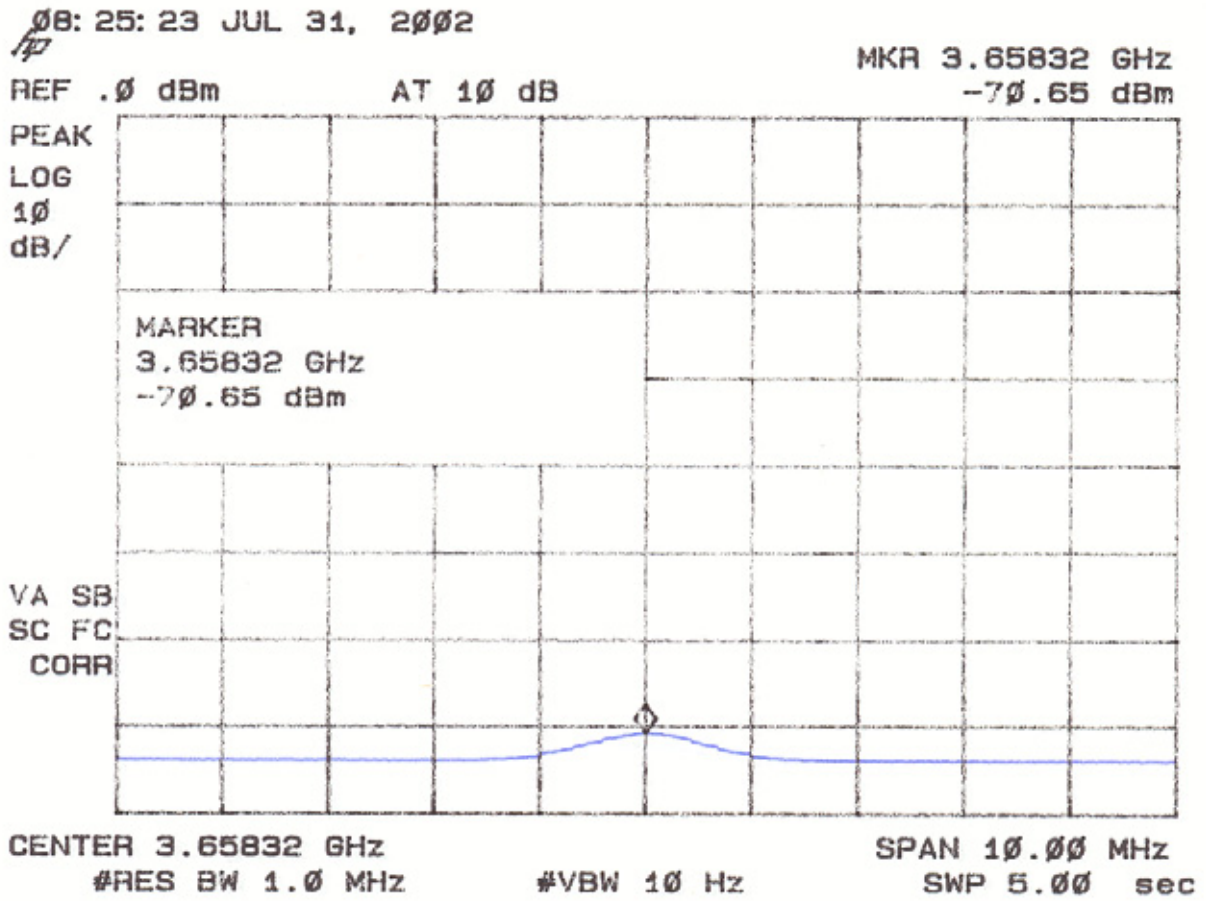

Figure 6d
Average Radiated Spurious Emission 15.247(c) - High

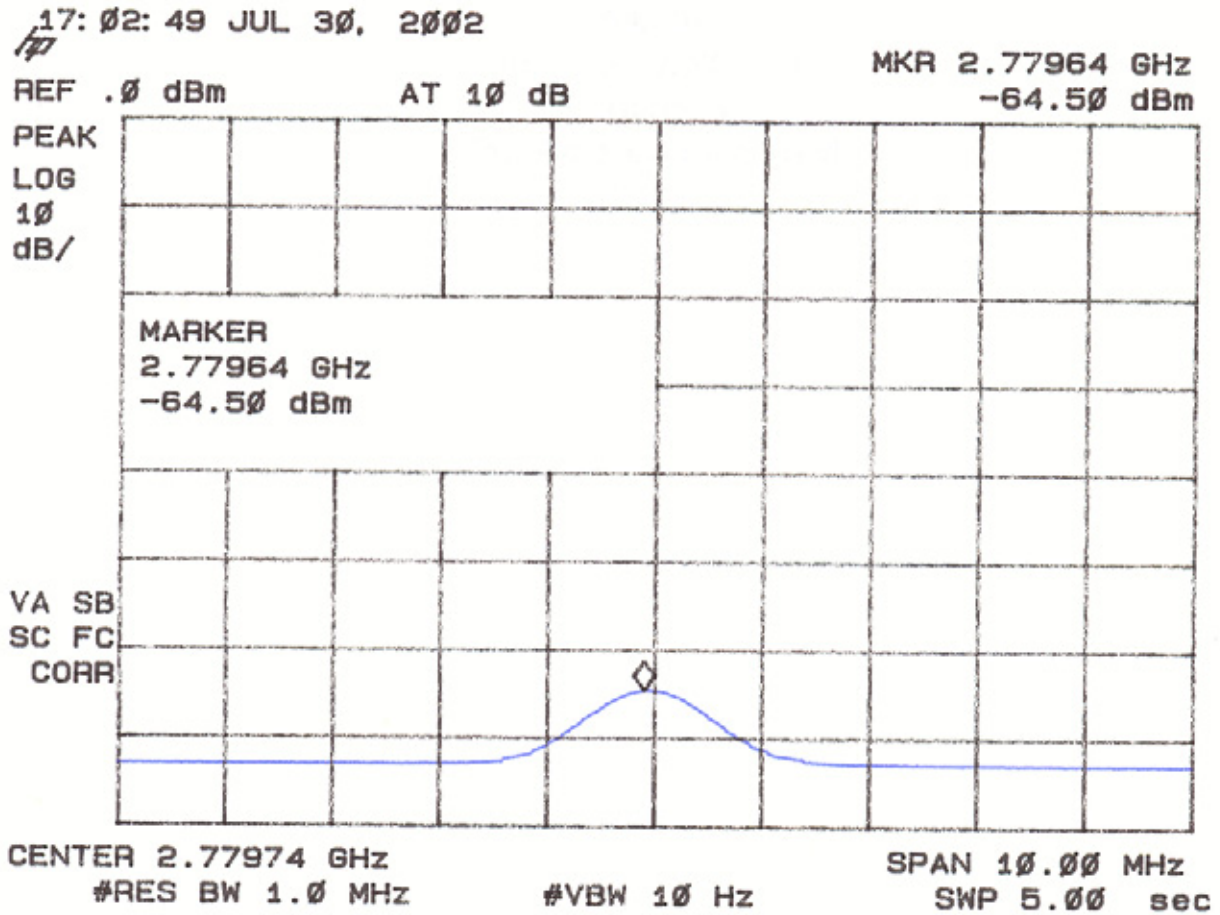

Figure 6e
Average Radiated Spurious Emission 15.247(c) - High

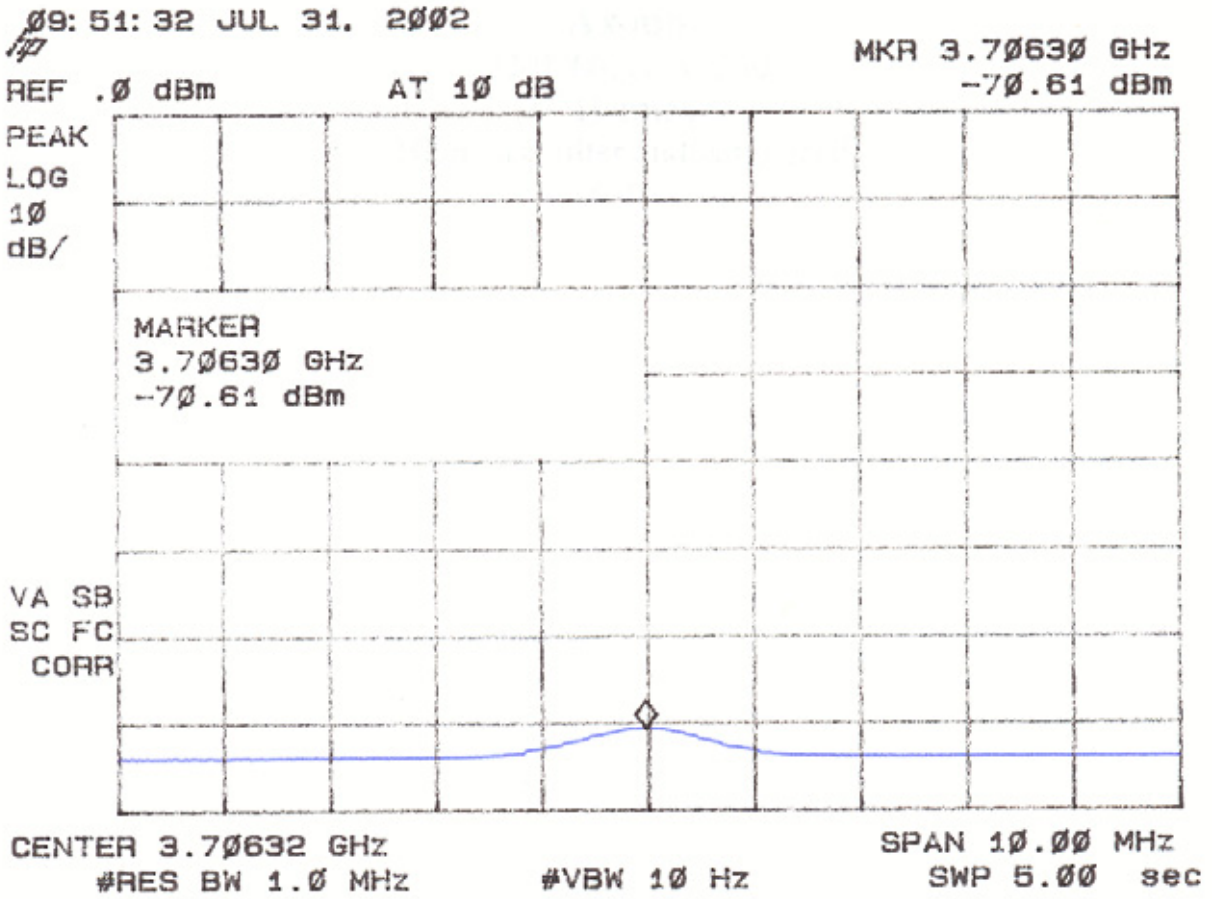

TABLE 5a. AVERAGE RADIATED SPURIOUS EMISSIONS

Test Date: July 30 & July 31, 2002
UST Project: 02-0266
Customer: Axonn L.L.C.
Product: AXC550 (Internal), Rev B Transmitter

Average Measurements > 1GHz (Low)

FREQ. (GHz)	TEST DATA* (dBm) @ 3m	AMP GAIN (dB)	ANT. FACTOR (dB)	CABLE LOSS (dB)	RESULTS (uV/m) @ 3m	FCC LIMITS (uV/m) @ 3m
2.716	-64.2	34.2	30.7	3.8	142.8	500.0

* = Data above 1 GHz adjusted by + 1 dB for high pass filter

SAMPLE CALCULATION:

RESULTS (uV/m @ 3m) = Antilog ((-64.2 - 34.2 + 30.7 + 3.8 + 107)/20) = 142.8

CONVERSION FROM dBm TO dBuV = 107 dB

Tester

Signature:  Name: David Blethen

TABLE 5b. AVERAGE RADIATED SPURIOUS EMISSIONS

Test Date: July 30 & July 31, 2002
UST Project: 02-0266
Customer: Axonn L.L.C.
Product: AXC550 (Internal), Rev B Transmitter

Average Measurements > 1GHz (Mid)

FREQ. (GHz)	TEST DATA* (dBm) @ 3m	AMP GAIN (dB)	ANT. FACTOR (dB)	CABLE LOSS (dB)	RESULTS (uV/m) @ 3m	FCC LIMITS (uV/m) @ 3m
2.743	-63.7	34.2	30.8	3.8	153.1	500.0
3.658	-69.6	33.8	33.2	5.0	126.0	500.0

* = Data above 1 GHz adjusted by + 1 dB for high pass filter

SAMPLE CALCULATION:

RESULTS (uV/m @ 3m) = Antilog ((-63.7 - 34.2 + 30.8 + 3.8 + 107)/20) = 153.1

CONVERSION FROM dBm TO dBuV = 107 dB

Tester

Signature: David P. Blethen Name: David Blethen

TABLE 5c. AVERAGE RADIATED SPURIOUS EMISSIONS

Test Date: July 30 & July 31, 2002
UST Project: 02-0266
Customer: Axonn L.L.C.
Product: AXC550 (Internal), Rev B Transmitter

Average Measurements > 1GHz (High)

FREQ. (GHz)	TEST DATA* (dBm) @ 3m	AMP GAIN (dB)	ANT. FACTOR (dB)	CABLE LOSS (dB)	RESULTS (uV/m) @ 3m	FCC LIMITS (uV/m) @ 3m
2.779	-63.5	34.1	30.8	3.9	160.3	500.0
3.706	-69.6	33.7	33.4	5.0	127.4	500.0

* = Data above 1 GHz adjusted by + 1 dB for high pass filter

SAMPLE CALCULATION:

RESULTS (uV/m @ 3m) = Antilog ((-63.5 - 34.1 + 30.8 + 3.9 + 107)/20) = 160.3

CONVERSION FROM dBm TO dBuV = 107 dB

Tester

Signature: David P. Blethen **Name:** David Blethen

2.11 Minimum 6 dB Bandwidth per FCC Section 15.247(a)(2)

The minimum requirement is given in Figure 7a through 7c. If the EUT incorporates different spreading codes or data rates these were each investigated and the one which produced the smallest 6 dB bandwidth was selected for test.

Figure 7a
6 dB Bandwidth per FCC Section 15.247(a)(2) - low

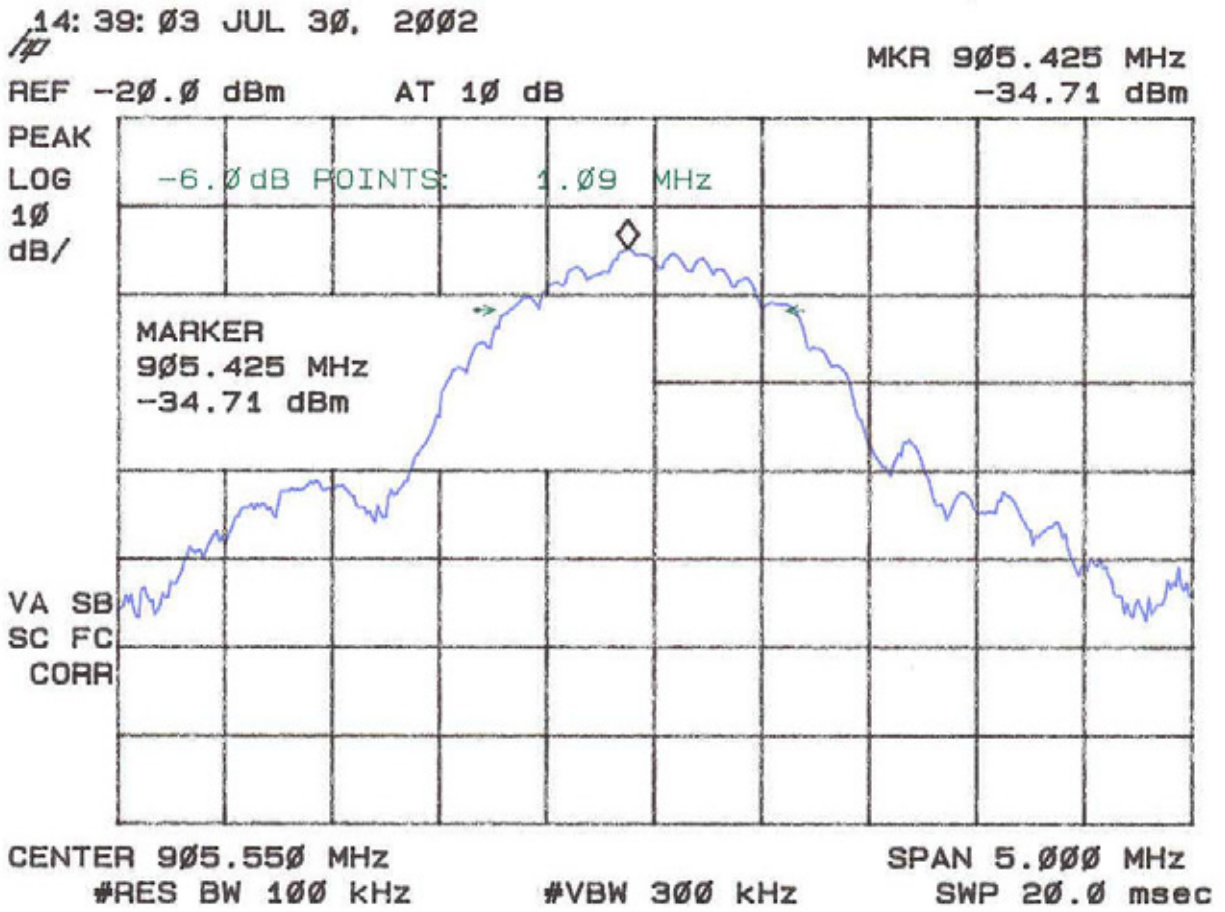

Figure 7b
6 dB Bandwidth per FCC Section 15.247(a)(2) – mid

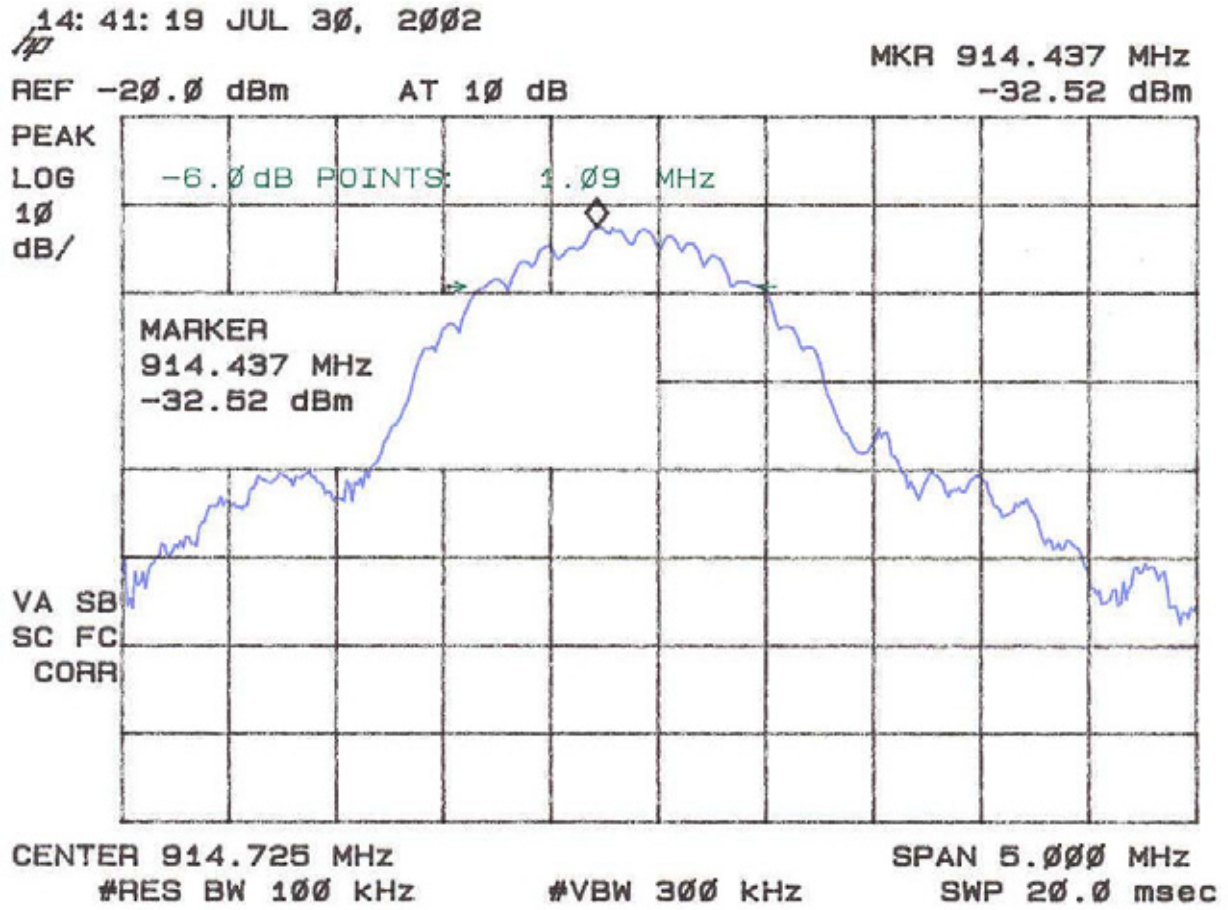
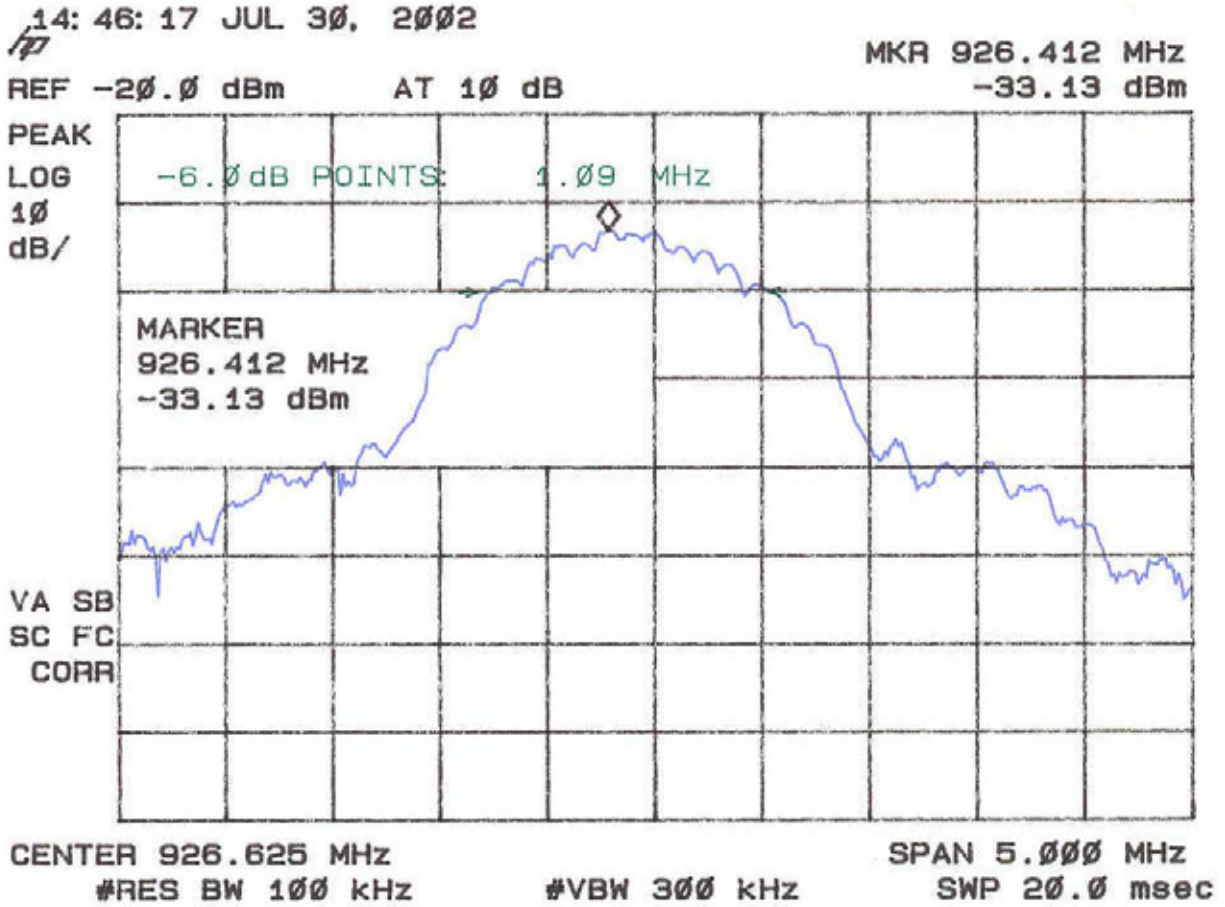

Figure 7c
6 dB Bandwidth per FCC Section 15.247(a)(2) - high



2.12 Power Spectral Density FCC Section 15.247(d)

The transmitter power spectral density averaged over any 1 second interval is given in Table 6 and Figure 8. If the EUT incorporates different spreading codes or data rates these were each investigated and the one which produced the smallest 6 dB bandwidth was selected for test.

This measurement was made on using a direct connection across the antenna terminals as directed by the manufacturer. The measurement was made by tuning a spectrum analyzer to the highest point of the maximized fundamental emission and zooming in on this portion of the emission utilizing the following spectrum analyzer settings: RBW = 3 kHz, VBW > RBW, span = 300 kHz, sweep = 100 seconds. The maximized point obtained by this method was then used to calculate the power spectral density as shown in Table 6.

**TABLE 6
POWER SPECTRAL DENSITY**

Test Date: August 9, 2002
UST Project: 02-0267
Customer: Axonn L.L.C.
Model: AXC550 (External), Rev B Transmitter

Frequency (GHz)	Test Data (dBm) Normalized to 1 Hz	Results (dBm)	FCC Limit (dBm)
905.4	4.3	4.3	8.0
914.4	5.0	5.0	8.0
926.4	5.6	5.6	8.0

* Measurement cable considered negligible

Tester
Signature:  **Name:** David Blethen

Figure 8a
Power Spectral Density 15.247(d) - low

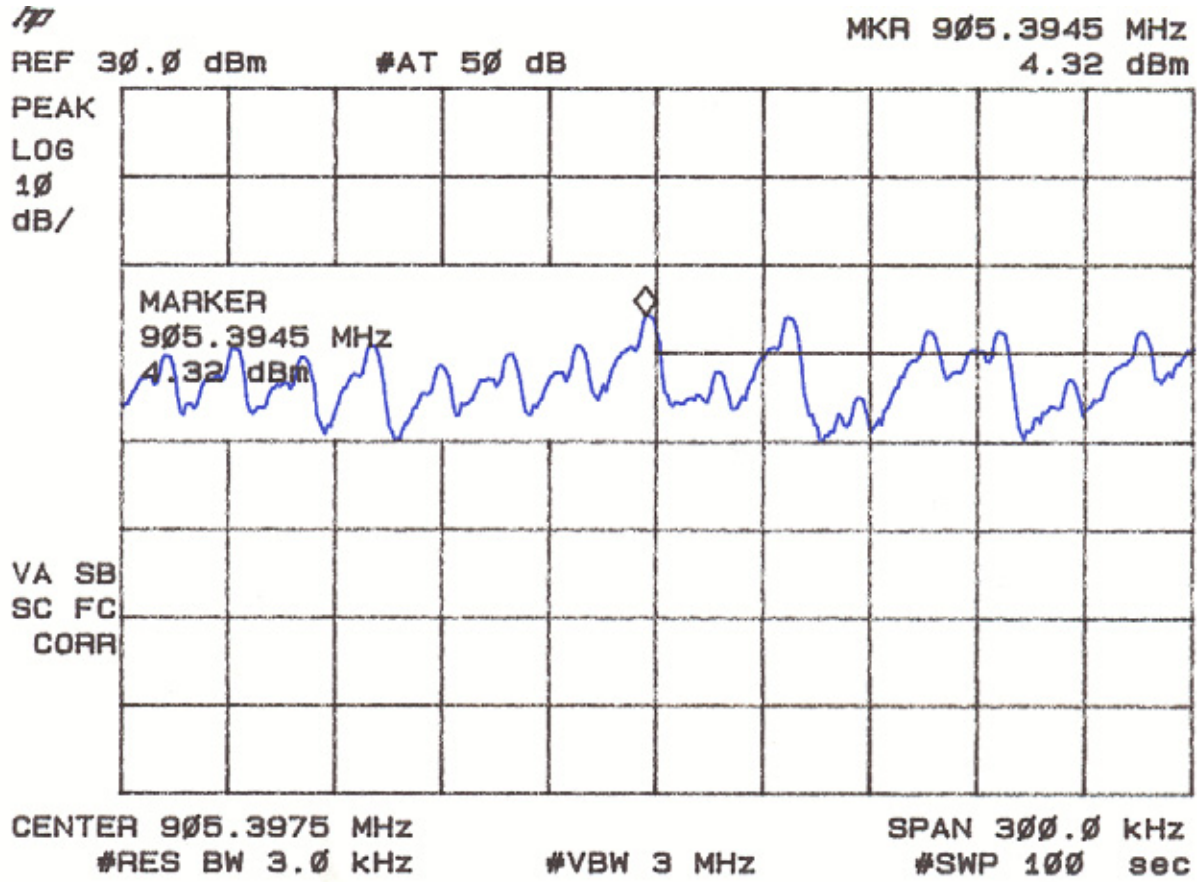

Figure 8b
Power Spectral Density 15.247(d) - mid

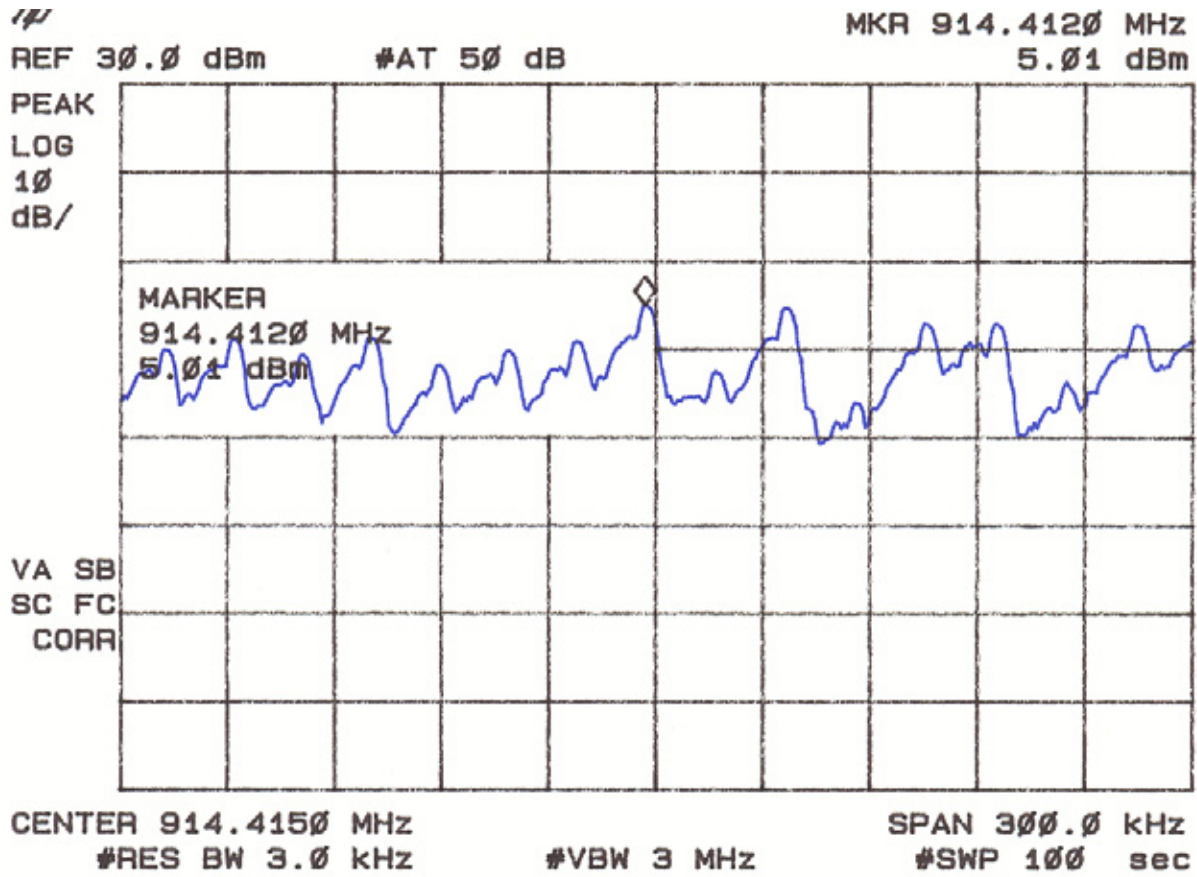
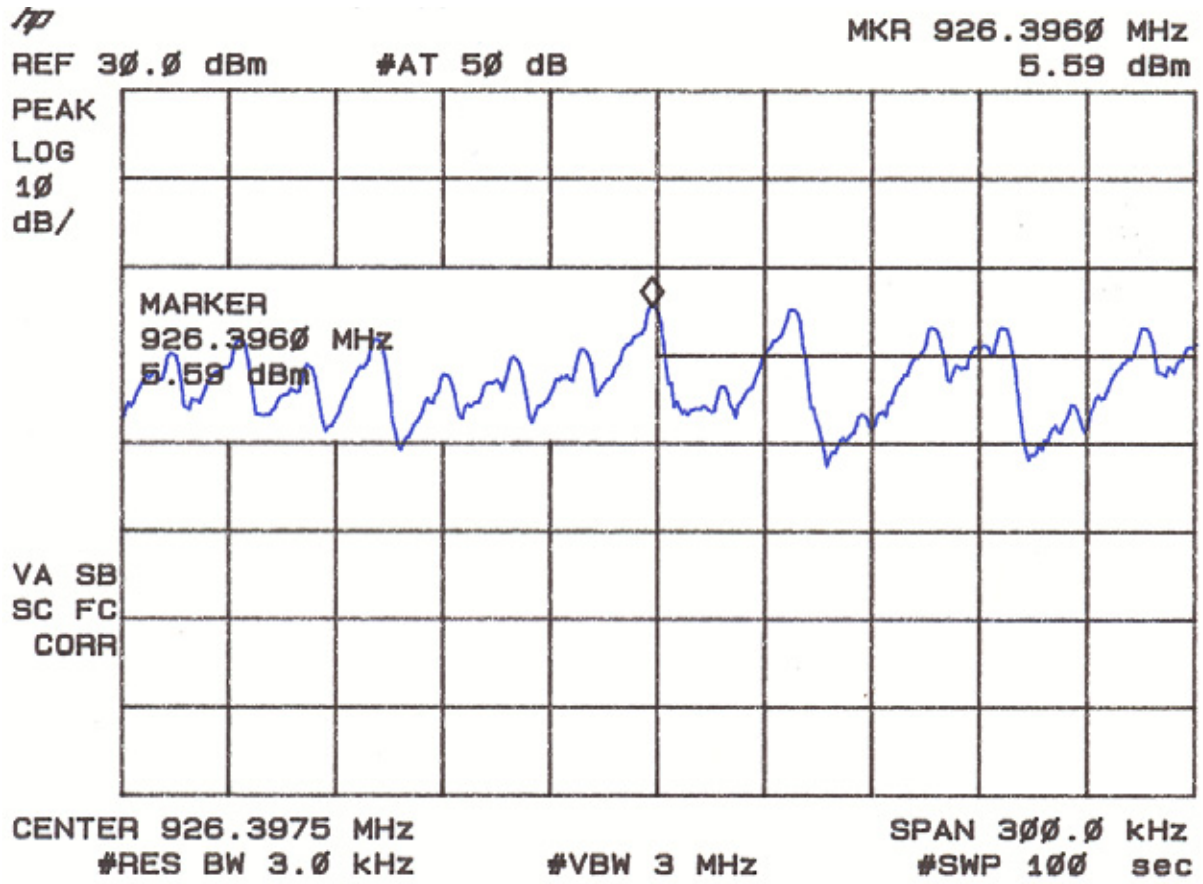

Figure 8c
Power Spectral Density 15.247(d) – high



2.13 Power Line Conducted Emissions for Transmitter FCC Section 15.207

The conducted voltage measurements have been carried out in accordance with FCC Section 15.207, with a spectrum analyzer connected to a LISN and the EUT placed into a continuous mode of transmit. The results are given in Table 7.

**TABLE 7. CONDUCTED EMISSIONS DATA
CLASS B**

Test Date: July 31, 2002
UST Project: 02-0266
Customer: Axonn L.L.C.
Product: AXC550 (Internal), Rev B Transmitter

FREQ. (MHz)	TEST DATA (dBm)		LISN LOSS (dB)		CABLE FACTOR (dB)	RESULTS (uV)		FCC LIMITS (uV)	MARGIN BELOW LIMIT (dB) PHASE	MARGIN BELOW LIMIT (dB) NEUTRAL
	PHASE	NEUTRAL	PHASE	NEUTRAL		PHASE	NEUTRAL			
4.07	-76.9	-69.8	0.1	0.1	0.3	33.4	75.8	250.0	17.5	10.4
13.25	-66.8	-63.1	0.1	0.1	0.6	110.7	169.8	250.0	7.1	3.4
17.80	-71.4	-67.7	0.1	0.1	0.7	66.1	101.3	250.0	11.6	7.8
21.34	-78.2	N/M	0.1	N/M	0.8	30.4	N/M	250.0	18.3	N/M
22.45	-79.8	-74.6	0.1	0.1	0.8	25.4	46.5	250.0	19.8	14.6
24.34	N/M	-76.2	N/M	0.1	0.8	N/M	38.3	250.0	N/M	16.3

N/M = Not Measured
 * - Quasi-Peak

SAMPLE CALCULATIONS:
 RESULTS uV = Antilog $(-76.9 + 0.1 + 0.3 + 107)/20$ = 33.4
 CONVERSION FROM dBm TO dBuV = 107 dB

Tested by David P. Blethen
 Signature: David P. Blethen Name: David Blethen

2.14 Radiated Emissions (47 CFR 15.109a)

Radiated emissions were evaluated from 30 to 5000 MHz. Measurements were made with the analyzer's bandwidth set to 120 kHz measurements for measurements made less than 1 GHz and 1 MHz for measurements over 1 GHz. Results are shown in Table 8.

TABLE 8. RADIATED EMISSIONS DATA

CLASS B

Test Date: July 31, 2002
UST Project: 02-0266
Customer: Axonn L.L.C.
Product: AXC550 (Internal), Rev B Transmitter

Frequency (MHz)	Receiver Reading (dBm) @3m	Correction Factor (dB)	Corrected Reading (uV/m)	FCC Limit (uV/m) @3m
No emissions were detected within 10 dB of the FCC Limit				

Tester
Signature: David P. Blethen **Name:** David Blethen

2.15 Power Line Conducted Emissions for Digital Device FCC Section 15.107

The conducted voltage measurements have been carried out in accordance with FCC Section 15.107, with a spectrum analyzer connected to a LISN and the EUT placed into a continuous mode of transmit. The results are given in Table 9.

TABLE 9. CONDUCTED EMISSIONS DATA – DIGITAL DEVICE

Test Date: July 31, 2002
UST Project: 02-0266
Customer: Axonn L.L.C.
Product: AXC550 (Internal), Rev B Transmitter

FREQ. (MHz)	TEST DATA (dBm)		LISN LOSS (dB)		CABLE FACTOR (dB)	RESULTS (uV)		FCC LIMITS (uV)	MARGIN BELOW LIMIT (dB) PHASE	MARGIN BELOW LIMIT (dB) NEUTRAL
	PHASE	NEUTRAL	PHASE	NEUTRAL		PHASE	NEUTRAL			
4.07	-76.9	-69.8	0.1	0.1	0.3	33.4	75.8	250.0	17.5	10.4
13.25	-66.8	-63.1	0.1	0.1	0.6	110.7	169.8	250.0	7.1	3.4
17.80	-71.4	-67.7	0.1	0.1	0.7	66.1	101.3	250.0	11.6	7.8
21.34	-78.2	N/M	0.1	N/M	0.8	30.4	N/M	250.0	18.3	N/M
22.45	-79.8	-74.6	0.1	0.1	0.8	25.4	46.5	250.0	19.8	14.6
24.34	N/M	-76.2	N/M	0.1	0.8	N/M	38.3	250.0	N/M	16.3

N/M = Not Measured

* - Quasi-Peak

SAMPLE CALCULATIONS:

RESULTS uV = Antilog ((-76.9 + 0.1 + 0.3 +107)/20) = 33.4
CONVERSION FROM dBm TO dBuV = 107 dB

Tested by David P. Blethen **Name:** David Blethen
Signature: