



# H.B. Compliance Solutions

## Intentional Radiator Test Report

For the

**Globalstar, Inc.**

**ST100**

Tested under

The FCC Rules contained in Title 47 of the CFR, Part 15.247 and ISSED RSS-247 Issue 2 Class II  
Permissive Change for

Digitally Transmitting Sequence

**Prepared for:**

Globalstar. Inc.

1351 Holiday Square Blvd.

Covington, LA 70433

**Prepared By:**

H.B. Compliance Solutions

5005 S. Ash Avenue, Suite # A-10

Tempe, Arizona 85282

**Reviewed By:**

Hoosamuddin Bandukwala



Cert # ATL-0062-E

**Engineering Statement:** The measurements shown in this report were made in accordance with the procedure indicated, and the emissions from this equipment were found to be within the limits applicable. I assume full responsibility for the accuracy and completeness of these measurements, and for the qualifications of all persons taking them. It is further stated that upon the basis of the measurement made, the equipment tested is capable of operation in accordance with the requirements of Part 15 of the FCC Rules under normal use and maintenance. All results contained herein relate only to the sample tested.



## Report Status Sheet

Revision #	Report Date	Reason for Revision
∅	February 23, 2022	Initial Issue

## Table of Contents

EXECUTIVE SUMMARY .....	4
1. Testing Summary.....	4
EQUIPMENT CONFIGURATION.....	5
1. Overview .....	5
2. Test Facility.....	6
3. Description of Test Sample .....	7
4. Equipment Configuration .....	7
5. Support Equipment .....	7
6. Ports and Cabling Information.....	7
7. Method of Monitoring EUT Operation.....	8
8. Mode of Operation.....	8
9. Modifications .....	8
10. Disposition of EUT .....	8
Criteria for Intentional Radiators .....	9
1. Radiated Spurious Emissions and Restricted Band .....	9
6. Test Equipment.....	12
7. Measurement Uncertainty.....	13

## EXECUTIVE SUMMARY

### 1. Testing Summary

These tests were conducted on a sample of the equipment for the purpose of demonstrating compliance with Part 15.247. All tests were conducted using measurement procedure from ANSI C63.10-2013, FCC Guidance document 558074 D01 v05r02 April 02, 2019 as appropriate.

Test Name	Test Method/Standard	ISED Standard	Result	Comments
Radiated Spurious Emissions & Restricted Band	15.247(d), 15.209(a), 15.205	RSS-247 (5.5) RSS-Gen (7.0)	Pass	

#### Class II Permissive Change:

ST100 is enclosed in the Recon Dynamics WACTag. Battery is enclosed to provide power to the ST100.



## EQUIPMENT CONFIGURATION

### 1. Overview

H.B Compliance Solutions was contracted by Recon Dynamics to perform testing on the ST100 under the quotation number Q22011002.

This document describes the test setups, test methods, required test equipment, and the test limit criteria used to perform compliance testing of the Globalstar, ST100.

The tests were based on FCC Part 15 Rules. The tests described in this document were formal tests as described with the objective of the testing was to evaluate compliance of the Equipment Under Test (EUT) to the requirements of the aforementioned specifications. Recon Dynamics should retain a copy of this document and it should be kept on file for at least five years after the manufacturing of the EUT has been permanently discontinued. The results obtained relate only to the item(s) tested.

<b>Product Name:</b>	ST100
<b>Model(s) Tested:</b>	ST100
<b>FCC ID:</b>	L2V-ST100
<b>IC ID:</b>	3989A-ST100
<b>Supply Voltage Input:</b>	Primary Power: +3.7 VDC
<b>Frequency Range:</b>	2402MHz - 2480MHz
<b>No. of Channels:</b>	Bluetooth Low Energy Specification
<b>Necessary Bandwidth</b>	N/A
<b>Type(s) of Modulation:</b>	GFSK (Bluetooth BLE)
<b>Range of Operation Power:</b>	0.0009W
<b>Emission Designator:</b>	N/A
<b>Channel Spacing(s)</b>	None
<b>Test Item:</b>	Pre-Production
<b>Type of Equipment:</b>	Portable
<b>Antenna Requirement (§15.203):</b>	Type of Antenna: PCB Trace Gain of Antenna: -0.14 dBi
<b>Environmental Test Conditions:</b>	Temperature: 15-35°C Humidity: 30-60% Barometric Pressure: 860-1060 mbar
<b>Modification to the EUT:</b>	None
<b>Evaluated By:</b>	Staff at H.B. Compliance Solutions
<b>Test Date(s):</b>	03/03/2022

## 2. Test Facility

All testing was performed at H.B. Compliance Solutions. This facility is located at 5005 S. Ash Avenue, Suite # A-10, Tempe AZ-85282. All equipment used in making physical determination is accurate and bears recent traceability to the National Institute of Standards and Technology.

Radiated Emissions measurements were performed in a GTEM chamber (equivalent to an Open Area Test Site). In accordance with §2.948(a)(3), a complete site description is contained at H.B. Compliance Solutions.

Test facility H.B. Compliance Solutions is an ANAB accredited test site. The ANAB certificate number is L2458. The scope of accreditation can be found on ANAB website [www.anab.org](http://www.anab.org)



### 3. Description of Test Sample

The Globalstar ST100 is an IoT board which is a simplex Satellite transmitter designed to send small packets of user defined data to a network of low earth orbiting (LEO) satellites using the Globalstar simplex satellite network. This module is used inside the Recon Dynamics WACTag which is a solar powered Satellite data communication device designed to communicate directly with the Globalstar Sattelite network to track, monitor, and manage outdoor assets nearly anywhere in the world without the need for a local gateway, phone or any other terrestrial wireless backhaul. The WACTag is powered by a battery.

### 4. Equipment Configuration

Ref. ID	Name / Description	Model Number	Serial Number
# 1	Globalstar (Recon Dynamics WACTag)	ST100	-

Table 1. Equipment Configuration

### 5. Support Equipment

All support equipment supplied is listed in the following Support Equipment List.

Ref ID	Name / Description	Manufacturer	Model #	Serial #
# 2	DC Power Supply	Lambda	LA-200	LA2-AA20-1433 3535
# 3	Laptop Computer	Acer	Aspire One	LUSAL0B13701153D401601

Table 2. Support Equipment

### 6. Ports and Cabling Information

Ref ID	Port name on the EUT	Cable Description	Qty.	Length (m)	Shielded? (Y/N)	Termination Box ID & Port ID
# 4	Power	2 Wire	1	2	N	DC Power Supply
# 5	USB	USB cable w/ Serial Adapater	1	1.5	N	Laptop Computer

Table 3. Ports and Cabling Information

## **7. Method of Monitoring EUT Operation**

A test receiver will be used to monitor the data transmission from the EUT.

## **8. Mode of Operation**

The EUT will be configured to transmit at maximum power level. Customer supplied test tool software (Putty Terminal) that allowed to program the EUT. Test mode was provided to select the lower, middle and upper band of the transmitter. This software allowed the selection of all the channels and to operate in CW and with modulation on. These settings were created for testing purpose only.

## **9. Modifications**

### **9.1 Modifications to EUT**

No modifications were made to the EUT

### **9.2 Modifications to Test Standard**

No Modifications were made to the test standard.

## **10. Disposition of EUT**

The test sample including all support equipment submitted to H.B Compliance Solutions for testing will be returned to Recon Dynamics at the completion of testing & certification.



## Criteria for Intentional Radiators

### 1. Radiated Spurious Emissions and Restricted Band

<b>Test Requirement(s):</b>	§15.247(d), 15.209(a), 15.205 and RSS-247 §5.5, RSS GEN §7.0	<b>Test Engineer(s):</b>	Sean E.
<b>Test Results:</b>	Pass	<b>Test Date(s):</b>	03/03/2022

**Test Procedures:** As required by 47 CFR 15.247 and RSS-247 §5.5, Radiated spurious measurements were made in accordance with the procedures of the FCC Guidance Document 558074 D01 and ANSI C63.10.

The EUT was placed on a non-reflective table inside a 3-meter semi-anechoic room. The EUT was set on continuous transmit.

The measurement antenna was placed at a distance of 3 meters from the EUT. During the tests, the antenna height and polarization as well as EUT azimuth were varied in order to identify the maximum level of emissions from the EUT. The frequency range up to the 10<sup>th</sup> harmonic was investigated included all the restricted band frequencies include 2483.5MHz. Measurement 10dB below the limits were not reported.

To get a maximum emission level from the EUT, the EUT was rotated throughout the X-axis, Y-axis and Z-axis. Worst case is X-axis

Detector Setting	Resolution Bandwidth	Video Bandwidth	Span
Peak	1MHz	3MHz	As necessary
Average	1MHz	10Hz	0 Hz

**Table 11. Analyzer Settings**

**Test Setup:**

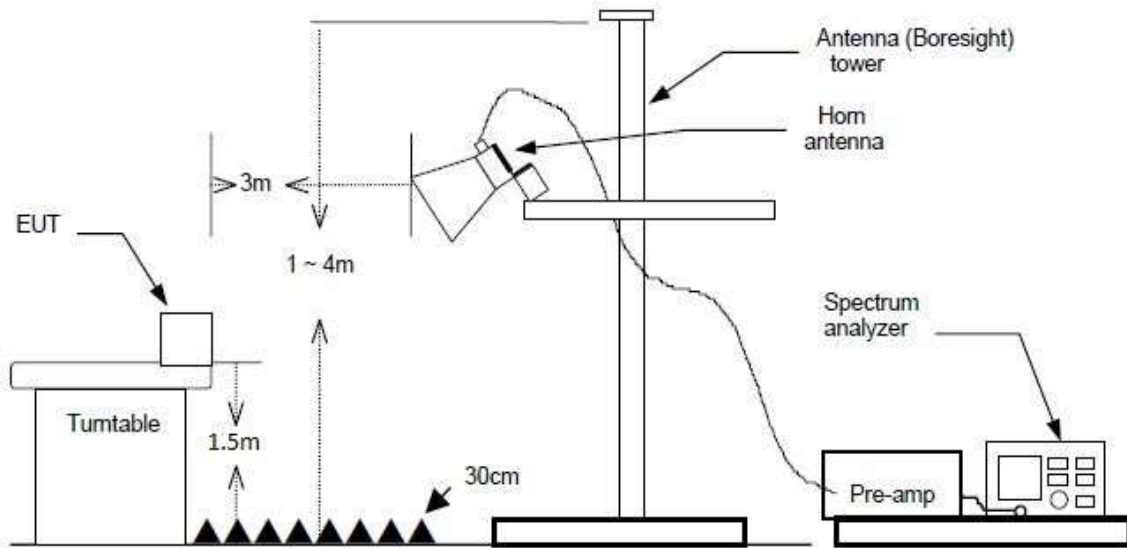

**Figure 5. Radiated Emission Above 1GHz Test Setup**

**Test Result:**

Frequency (MHz)	Peak Amplitude (dbuV/m)	Peal Limit (dBuV/m)	Average Amplitude (dBuV/m)	Average Limit (dBuV/m)
4804*	34.88	74.0	-	54.0
7206	-	115.5	-	95.5

**Table 12 - Spurious Radiated Emission Data – Low Band - Internal Antenna**

Frequency (MHz)	Peak Amplitude (dbuV/m)	Peak Limit (dBuV/m)	Average Amplitude (dBuV/m)	Average Limit (dBuV/m)
4880*	36.03	74.0	-	54.0
7320	-	115.5	-	95.5

**Table 13– Spurious Radiated Emission Data – Mid Band - Internal Antenna**

Frequency (MHz)	Peak Amplitude (dbuV/m)	Peak Limit (dBuV/m)	Average Amplitude (dBuV/m)	Average Limit (dBuV/m)
4960*	38.23	74.0	-	54.0
7440	-	115.5	-	95.5

**Table 14- Spurious Radiated Emission Data – High Band - Internal Antenna**

**NOTE 1:** There were no detectable emissions above the 2nd harmonic.

**NOTE 2:** Frequency marked with “\*” falls under the restricted band

## 6. Test Equipment

Equipment	Manufacturer	Model	Serial #	Last Cal Date	Cal Due Date
Spectrum Analyzer	Hewlett Packard	8563E	3821A09316	Apr/28/21	Apr/28/22
High Pass Filter	Mini-Circuits	VHF-3100+	1023	Verified	
Power Supply	Hewlett Packard	E3610A	KR83021468	Verified	
High Pass Filter	Mini-Circuits	VHF-1320+	1034	Verified	
Attenuator 10dB	Huber+Suhner	6810.17.A	747300	Verified	
Horn Antenna	Com-Power	AHA-118	711150	Dec/17/20	Dec/17/22
Antenna	EMCO	GTEM 5417	1063	Verified	

Table 19 – Test Equipment List

**\*Statement of Traceability:** Test equipment is maintained and calibrated on a regular basis. All calibrations have been performed by a 17025 accredited test facility, traceable to National Institute of Standards and Technology (NIST)

## 7. Measurement Uncertainty

ISO/IEC 17025 requires that an estimate of the measurement uncertainties associated with the emissions test results be included in the report. These measurements figures are calculated in accordance with ETSI TR 100 028 Parts 1 and 2. Instrumentation measurement uncertainty has **not** been taken into account to determine compliance.

The following measurement uncertainty values have been calculated as show in the table below:

Measured Parameter	Measurement Unit	Frequency Range	Expanded Uncertainty
Conducted Emissions (AC Power)	dBuV or dBuA	150kHz – 30MHz	± 4.3dB
Radiated Emission below 30MHz	dBuV/m	9kHz-30MHz	± 2.96dB
Radiated Emissions below 1GHz	dBuV/m	30 – 1000MHz	± 5.6dB
Radiated Emissions above 1GHz	dBuV/m	1 – 26.5GHz	± 4.1dB

The reported expanded uncertainty has been estimated at a 95% confidence level (k=2)

**END OF TEST REPORT**