



The University of Michigan Radiation Laboratory  
3228 EECS Building  
Ann Arbor, Michigan 48109-2122 USA  
Tel: (734) 483-4211  
Fax: (734) 647-2106  
e-mail: liepa@umich.edu

Testing of

# Electromagnetic Emissions

per

USA: CFR Title 47, Part 15.253  
Canada: IC RSS-210/GENe

are herein reported for

## Delphi Electronics & Safety L2C0055TR

Test Report No.: 417124-681  
Copyright © 2014

Applicant/Provider:  
Delphi Electronics & Safety  
One Corporate Center, Kokomo Indiana 46904-9005 USA  
Phone: 765 451-5770, Fax: 765-451-0900  
Contact Person: Brian W. Johnson; brian.w.johnson@delphi.com

Measured by: Valdis V. Liepa Report Approved by: Valdis V. Liepa  
Valdis V. Liepa, Ph.D. Valdis V. Liepa, Ph.D.  
Report by: Valdis V. Liepa Report Date of Issue: November 21, 2014  
Valdis V. Liepa, Ph.D.

Results of testing completed on (or before) November 16, 2014 are as follows.

**Emissions:** The transmitter intentional emissions **COMPLY** with the regulatory limit(s) by no less than 13.8 dB.  
Transmit chain spurious harmonic emissions **COMPLY** by no less than 21.3 dB.

## Contents

<b>1</b>	<b>Test Specifications, General Procedures, and Location</b>	<b>4</b>
1.1	Test Specification and General Procedures . . . . .	4
1.2	Test Location and Equipment Used . . . . .	5
<b>2</b>	<b>Configuration and Identification of the Equipment Under Test</b>	<b>6</b>
2.1	Description and Declarations . . . . .	6
2.1.1	EUT Configuration . . . . .	6
2.1.2	Modes of Operation . . . . .	6
2.1.3	Variants . . . . .	6
2.1.4	Test Samples . . . . .	7
2.1.5	Functional Exerciser . . . . .	7
2.1.6	Modifications Made . . . . .	7
2.1.7	Production Intent . . . . .	7
2.1.8	Declared Exemptions and Additional Product Notes . . . . .	7
<b>3</b>	<b>Emissions</b>	<b>8</b>
3.1	General Test Procedures . . . . .	8
3.1.1	Radiated Test Setup and Procedures . . . . .	8
3.1.2	Conducted Emissions Test Setup and Procedures . . . . .	11
3.1.3	Power Supply Variation . . . . .	11
3.2	Intentional Emissions . . . . .	12
3.2.1	Fundamental Emission Pulsed Operation . . . . .	12
3.2.2	Fundamental Emission Bandwidth . . . . .	15
3.2.3	Fundamental Emission . . . . .	18
3.2.4	Exposure and Potential Health Hazard . . . . .	19
3.3	Unintentional Emissions . . . . .	20
3.3.1	Transmit Chain Spurious Emissions . . . . .	20

## List of Tables

1	The University of Michigan Radiation Laboratory Equipment List. . . . .	5
2	EUT Declarations. . . . .	6
3	Pulsed Emission Characteristics (Duty Cycle). . . . .	12
4	Intentional Emission Bandwidth. . . . .	15
5	Fundamental Radiated Emissions. . . . .	18
6	Electromagnetic Field Exposure. . . . .	19
7	Transmit Chain Spurious Emissions. . . . .	20

## List of Figures

1	Photos of EUT. . . . .	6
2	EUT Test Configuration Diagram. . . . .	7
3	Radiated Emissions Diagram of the EUT. . . . .	8
4	Radiated Emissions Test Setup Photograph(s). . . . .	10
5	Pulsed Emission Characteristics (Duty Cycle). . . . .	13
5	Pulsed Emission Characteristics (Duty Cycle). . . . .	14
6	Intentional Emission Bandwidth. . . . .	16
6	Intentional Emission Bandwidth. . . . .	17

# 1 Test Specifications, General Procedures, and Location

## 1.1 Test Specification and General Procedures

The ultimate goal of Delphi Electronics & Safety is to demonstrate that the Equipment Under Test (EUT) complies with the Rules and/or Directives below. Detailed in this report are the results of testing the Delphi Electronics & Safety L2C0055TR for compliance to:

Country/Region	Rules or Directive	Referenced Section(s)
United States	Code of Federal Regulations	CFR Title 47, Part 15.253
Canada	Industry Canada	IC RSS-210/GENe

Delphi Electronics & Safety has determined that the equipment under test is subject to the rules and directives above at the date of this testing. In conjunction with these rules and directives, the following specifications and procedures are followed herein to demonstrate compliance (in whole or in part) with these regulations.

ANSI C63.4-2003	"Methods of Measurement of Radio-Noise Emissions from Low-Voltage Electrical and Electronic Equipment in the Range of 9 kHz to 40 GHz"
KDB 200443 D02 MMW	"FCC/TCB Council Millimeter Wave Test Procedures"
Industry Canada	"The Measurement of Occupied Bandwidth"

## 1.2 Test Location and Equipment Used

**Test Location** The EUT was fully tested by **The University of Michigan Radiation Laboratory**, 3228 EECS Building, Ann Arbor, Michigan 48109-2122 USA. The Test Facility description and attenuation characteristics are on file with the FCC Laboratory, Columbia, Maryland (FCC Reg. No: 91050) and with Industry Canada, Ottawa, ON (File Ref. No: IC 2057A-1).

**Test Equipment** Pertinent test equipment used for measurements at this facility is listed in Table 1. The quality system employed at The University of Michigan Radiation Laboratory has been established to ensure all equipment has a clearly identifiable classification, calibration expiry date, and that all calibrations are traceable to the SI through NIST, other recognized national laboratories, accepted fundamental or natural physical constants, ratio type of calibration, or by comparison to consensus standards.

Table 1: The University of Michigan Radiation Laboratory Equipment List.

<b>Test Instrument</b>	<b>Manufacturer/Model</b>	<b>Q Number</b>
Spectrum Analyzer (9kHz-26GHz)	Hewlett-Packard 8593E, SN: 3412A01131	HP8593E1
Spectrum Analyzer (10Hz-2.9GHz)	Hewlett-Packard 8593E, SN: 3412A01131	HP8560E1
Power Meter	Hewlett-Packard, 432A	HP432A1
Harmonic Mixer (26-40 GHz)	Hewlett-Packard 11970A, SN: 3003A08327	HP11970A1
Harmonic Mixer (40-60 GHz)	Hewlett-Packard 11970U, SN: 2332A00500	HP11970U1
Harmonic Mixer (75-110 GHz)	Hewlett-Packard 11970W, SN: 2521A00179	HP11970W1
Harmonic Mixer (140-220 GHz)	Pacific Millimeter Prod., GMA, SN: 26	PMPGMA1
S-Band Std. Gain Horn	S/A, Model SGH-2.6	SBAND1
C-Band Std. Gain Horn	University of Michigan, NRL design	CBAND1
XN-Band Std. Gain Horn	University of Michigan, NRL design	XNBAND1
X-Band Std. Gain Horn	S/A, Model 12-8.2	XBAND1
X-band horn (8.2- 12.4 GHz)	Narda 640	XBAND2
X-band horn (8.2- 12.4 GHz)	Scientific Atlanta , 12-8.2, SN: 730	XBAND3
K-band horn (18-26.5 GHz)	FXR, Inc., K638KF	KBAND1
Ka-band horn (26.5-40 GHz)	FXR, Inc., U638A	KABAND1
U-band horn (40-60 GHz)	Custom Microwave, HO19	UBAND1
W-band horn(75-110 GHz)	Custom Microwave, HO10	WBAND1
G-band horn (140-220 GHz)	Custom Microwave, HO5R	GBAND1
Bicone Antenna (30-250 MHz)	University of Michigan, RLBC-1	LBBIC1
Bicone Antenna (200-1000 MHz)	University of Michigan, RLBC-2	HBBIC1
Dipole Antenna Set (30-1000 MHz)	University of Michigan, RLDP-1,-2,-3	UMDIP1
Dipole Antenna Set (30-1000 MHz)	EMCO 3121C, SN: 992 (Ref. Antennas)	EMDIP1
Active Rod Antenna (30 Hz-50 MHz)	EMCO 3301B, SN: 3223	EMROD1
Active Loop Antenna (30 Hz-50 MHz)	EMCO 6502, SN:2855	EMLOOP1
Ridge-horn Antenna (300-5000 MHz)	University of Michigan	UMRH1
Magnetic Field Strength Probe	HP 11941A	HPMFSP1
Electric Field Strength Probe	EG&G ACD-4A(R)	EGGACD41
Amplifier (5-1000 MHz)	Avantek, A11-1, A25-1S	AVAMP1
Amplifier (5-4500 MHz)	Avantek	AVAMP2
Amplifier (4.5-13 GHz)	Avantek, AFT-12665	AVAMP3
Amplifier (6-16 GHz)	Trek	TRAMP1
Amplifier (16-26 GHz)	Avantek	AVAMP4
LISN Box	University of Michigan	UMLISN1
Signal Generator	Hewlett-Packard 8657B	HPSG1

## 2 Configuration and Identification of the Equipment Under Test

### 2.1 Description and Declarations

The EUT is an automotive radar. The EUT is approximately 8 x 6 x 2 cm in dimension, and is depicted in Figure 1. It is powered by a 13.2 VDC vehicle power system. In use, this device is permanently affixed in a motor vehicle. Table 2 outlines provider declared EUT specifications.



Figure 1: Photos of EUT.

Table 2: EUT Declarations.

General Declarations			
<b>Equipment Type:</b>	Radar	<b>Country of Origin:</b>	Not Declared
<b>Nominal Supply:</b>	13.2 VDC	<b>Oper. Temp Range:</b>	Not Declared
<b>Frequency Range:</b>	76.049 to 76.985 GHz	<b>Antenna Dimension:</b>	4 cm
<b>Antenna Type:</b>	integral patch arrays	<b>Antenna Gain:</b>	14 dBi (declared)
<b>Number of Channels:</b>	more than two	<b>Channel Spacing:</b>	Not Declared
<b>Alignment Range:</b>	Not Declared	<b>Type of Modulation:</b>	FMCW
United States			
<b>FCC ID Number:</b>	L2C0055TR	<b>Classification:</b>	FDS
Canada			
<b>IC Number:</b>	3432A-0055TR	<b>Classification:</b>	Radar, Vehicular Device

#### 2.1.1 EUT Configuration

The EUT is configured for testing as depicted in Figure 2.

#### 2.1.2 Modes of Operation

The manufacturer considers the modes of operation of this product to be of a proprietary nature. Please reference the confidential Modes of Operation exhibit for complete details.

#### 2.1.3 Variants

There is only a single variant of the EUT, as tested.

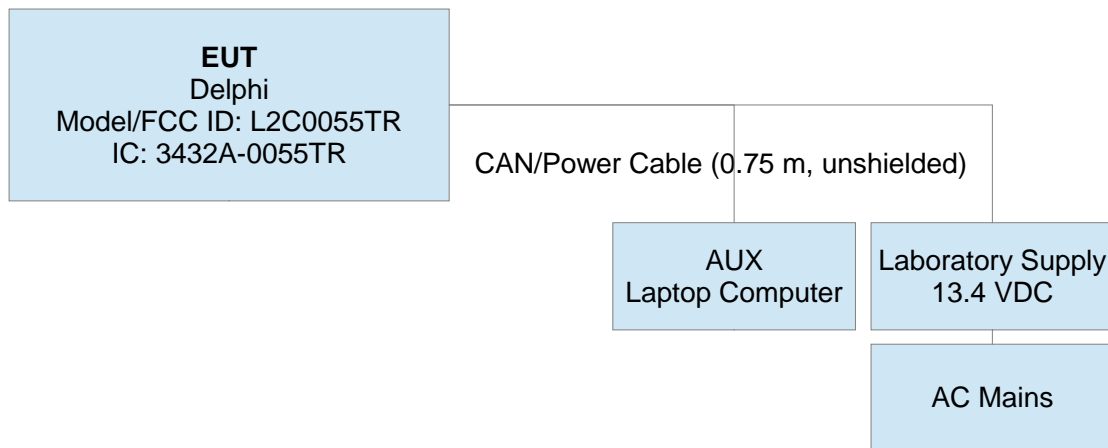

Figure 2: EUT Test Configuration Diagram.

#### 2.1.4 Test Samples

Three samples were provided; two normal operating (modulating) devices capable of re-programming via an auxiliary computer into each of the different modulations employed, and into each channel of operation, as well as CW transmission at select frequencies. One further sample was provided, unsealed, for photos.

#### 2.1.5 Functional Exerciser

Normal operating EUT functionality was verified by CAN bus activity.

#### 2.1.6 Modifications Made

No modifications were made to the EUT.

#### 2.1.7 Production Intent

The EUT appears to be a production ready sample.

#### 2.1.8 Declared Exemptions and Additional Product Notes

The EUT is permanently installed in a transportation vehicle. As such, digital emissions are exempt from US and Canadian digital emissions regulations (per FCC 15.103(a) and IC correspondence on ICES-003). Narrow pulses arise as the FMCW signal chirps past the receiver tuned frequency. To avoid amplitude measurement error due to Pulse Desensitization, we measure peak emissions only when the radar is either placed into CW mode or when the signal Dwells at a single frequency for an extended period of time. In computation of duty cycle for the FMCW chirp modulation, pulse desensitization may cause the measurement receiver to report wider than actual pulse widths, and thus greater on-time and lower duty cycle based on the calculation method. Duty cycle in the FMCW modes is thus a worst-case computation, applied to a properly measured peak emission.

### 3 Emissions

#### 3.1 General Test Procedures

##### 3.1.1 Radiated Test Setup and Procedures

Radiated electromagnetic emissions from the EUT are first evaluated in our shielded fully anechoic chamber. Spectrum and modulation characteristics of all emissions are recorded, and emissions above 1 GHz are fully characterized. The anechoic chamber contains a set-up similar to that of our outdoor 3-meter site, with a turntable and antenna mast. Instrumentation, including spectrum analyzers and other test equipment as detailed in Section 1.2 are employed. After indoor pre-scans, emission measurements are made on our outdoor 3-meter Open Area Test Site (OATS). If the EUT connects to auxiliary equipment and is table or floor standing, the configurations prescribed in ANSI C63.4 / CISPR-22 are followed. Alternatively, a layout closest to normal use (as declared by the provider) is employed if the resulting emissions appear to be worst-case in such a configuration. See Figure 3. All

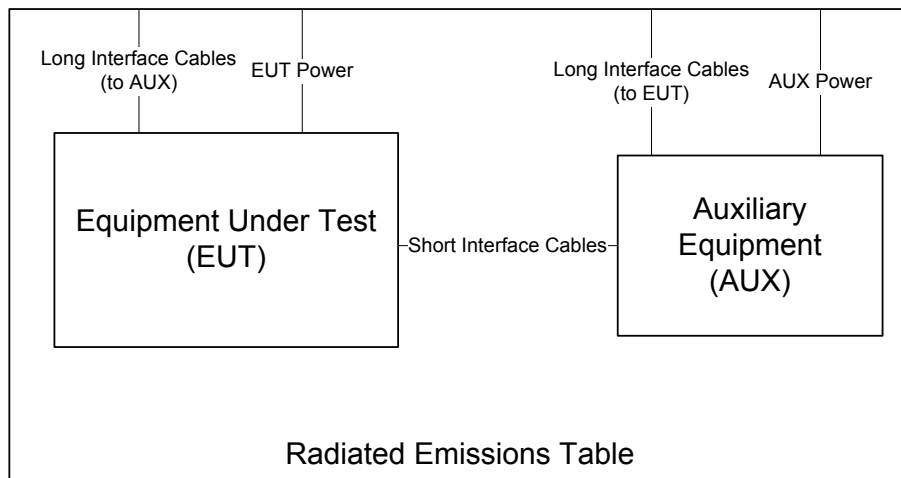

Figure 3: Radiated Emissions Diagram of the EUT.

intentionally radiating elements that are not fixed-mounted in use are placed on the test table lying flat, on their side, and on their end (3-axes) and the resulting worst case emissions are recorded. If the EUT is fixed-mounted in use, measurements are made with the device oriented in the manner consistent with installation and then emissions are recorded.

If the EUT exhibits spurious emissions due to internal receiver circuitry, such emissions are measured with an appropriate carrier signal applied. For devices with intentional emissions below 30 MHz, a shielded loop antenna is used as the test antenna. It is placed at a 1 meter receive height and appropriate low frequency magnetic field extrapolation to the regulatory limit distance is employed. Emissions between 30 MHz and 1 GHz are measured using tuned dipoles and/or calibrated broadband antennas. For both horizontal and vertical polarizations, the test antenna is raised and lowered from 1 to 4 m in height until a maximum emission level is detected. The EUT is then rotated through 360° in azimuth until the highest emission is detected. The test antenna is then raised and lowered one last time from 1 to 4 m and the worst case value is recorded. Emissions above 1 GHz are characterized using standard gain horn antennas or calibrated broadband ridge-horn antennas. Care is taken to ensure that test receiver resolution and video bandwidths meet the regulatory requirements, and that the emission bandwidth of the EUT is not reduced. Photographs of the test setup employed are depicted in Figure 4.

Where regulations allow for direct measurement of field strength, power values (dBm) measured on the test receiver / analyzer are converted to dBμV/m at the regulatory distance, using

$$E_{dist} = 107 + P_R + K_A - K_G + K_E - C_F$$

where  $P_R$  is the power recorded on spectrum analyzer, in dBm,  $K_A$  is the test antenna factor in dB/m,  $K_G$  is the combined pre-amplifier gain and cable loss in dB,  $K_E$  is duty correction factor (when applicable) in dB, and  $C_F$  is



a distance conversion (employed only if limits are specified at alternate distance) in dB. This field strength value is then compared with the regulatory limit. If effective isotropic radiated power (EIRP) is compute, it is computed as

$$EIRP(dBm) = E_{3m}(dB\mu V/m) - 95.2.$$

When presenting data at each frequency, the highest measured emission under all possible EUT orientations (3-axes) is reported.

Where regulations call for substitution method measurements, the EUT is replaced by a substitution dipole or standard gain antenna if field strength measurements indicate the emission is close to the regulatory limit. This antenna is co-polarized with the test antenna and tuned (when necessary) to the emission frequency, after which the test antenna height is again optimized. The substitution antenna input signal level is then adjusted such that its emission is equal to the level measured from the EUT. The signal level applied to the substitution antenna is then recorded. Effective isotropic radiated power (EIRP) and effective radiated power (ERP) in dBm are formulated from

$$EIRP = P_T - G_A = ERP + 2.16, \quad (1)$$

where  $P_T$  is the power applied to substitution antenna in dBm, including correction for cable loss, and  $G_A$  is the substitution antenna gain, in dBi.

When microwave measurements are made at a range different than the regulatory distance or made at close-range to improve receiver sensitivity, the reading is corrected back to the regulatory distance. This is done using a 20 dB/decade far-field behavior relation and a 40 dB/decade near-field relation, as outlined in the FCCs mm-wave measurement procedures. The near-field/far-field boundary (N/F) is computed based on

$$N/F = 2D^2/\lambda$$

where  $D$  is the maximum dimension of the transmitter or receiver antenna , and  $\lambda$  is the wavelength at the measurement frequency. For example, suppose  $N/F = 2$  m, but the measurement is made at 1 m. Here, the 40 dB/decade relation would be applied from 1 to 2 m, and the 20 dB/decade relation would be applied from 2 to 3 m. In dB, this gives a 15.6 dB adjustment. Typically, for microwave measurements either the receive antenna is connected directly to the spectrum analyzer, or it is connected to an external mixer followed by an insignificant length of cable. In this case, no cable loss term is used and mixer conversion losses are programmed in the spectrum analyzer to be included in the recorded dB values.

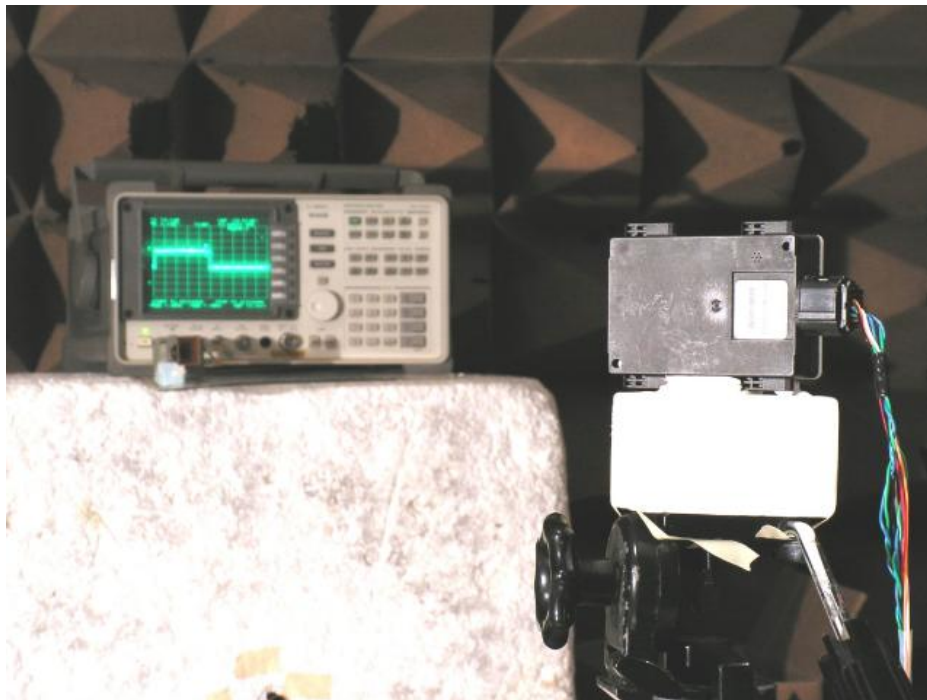

Figure 4: Radiated Emissions Test Setup Photograph(s).

### **3.1.2 Conducted Emissions Test Setup and Procedures**

**Vehicle Power Conducted Spurious** The EUT is not subject to power line conducted emissions regulations as it is powered solely by the vehicle power system for use in said motor vehicle.

### **3.1.3 Power Supply Variation**

Tests at extreme supply voltages are made if required by the the procedures specified in the test standard, and results of this testing are detailed in this report.

## 3.2 Intentional Emissions

### 3.2.1 Fundamental Emission Pulsed Operation

The details and results of testing the EUT for pulsed operation are summarized in Table 3. Plots showing the measurements made to obtain these values are provided in Figure 5.

Table 3: Pulsed Emission Characteristics (Duty Cycle).

**Frequency Range**  
f > 1 000 MHz

**Det**  
Pk

**IFBW**  
1 MHz

**VBW**  
3 MHz

**Test Date:** 22-Sep-14  
**Test Engineer:** Valdis V. Liepa  
**EUT:** Delphi SRR2 77GHz  
**Meas. Distance:** 30 cm

Pulsed Operation / Duty Cycle										
Transmit Mode	Voltage (V)	Test Frequency <sup>(1)</sup> (GHz)	Cycle Time (ms)	On-Time <sup>(2)</sup> (ms)	Exposure Duty Correction <sup>(3)</sup> (dB)	FMCW Period (ms)	Max Dwell/Chirp <sup>(4)</sup> (ms)	Chirps / On-Time <sup>(5)</sup> (#)	Max On-Time/Cycle (ms)	Spread Duty <sup>(6)</sup> (dB)
LR FMCW worst case (subfigure (a))	13.4	76.793	50.0	18.00	-4.4	0.033	0.00483	545	2.635	-12.8
MR FMCW worst case (subfigure (b))	13.4	76.460	50.0	18.00	-4.4	0.033	0.00483	548	2.648	-12.8

(1) Mid Range and Long Range Chirp Duty is worst-case at highest emission detected due to longest dwell time at these frequencies

(2) Mid-Range On-Time = 18 ms (FMCW sweep – wide band).  
Long Range On-Time = 18.0 ms (FMCW sweep – narrow band)

(3) Exposure Duty Correction =  $10 \cdot \log(\text{Total On-Time} / \text{Cycle-Time})$ ;

(4) Max Dwell / MHz / Chirp is the measured worst case pulse length measured in any given 1 MHz RBW, per chirp.

(5) Chirps / On-Time = On-Time / FMCW Period

(6) Spread Duty =  $10 \cdot \log_{10}(\text{Total On-Time} / \text{Cycle} / \text{Total Cycle Time}) = 10 \cdot \log_{10}(2.635\text{ms} / 50\text{ms}) = -12.8$

Equipment Used: HP8560E1, HP8593E1, HP11970W1, WBAND1

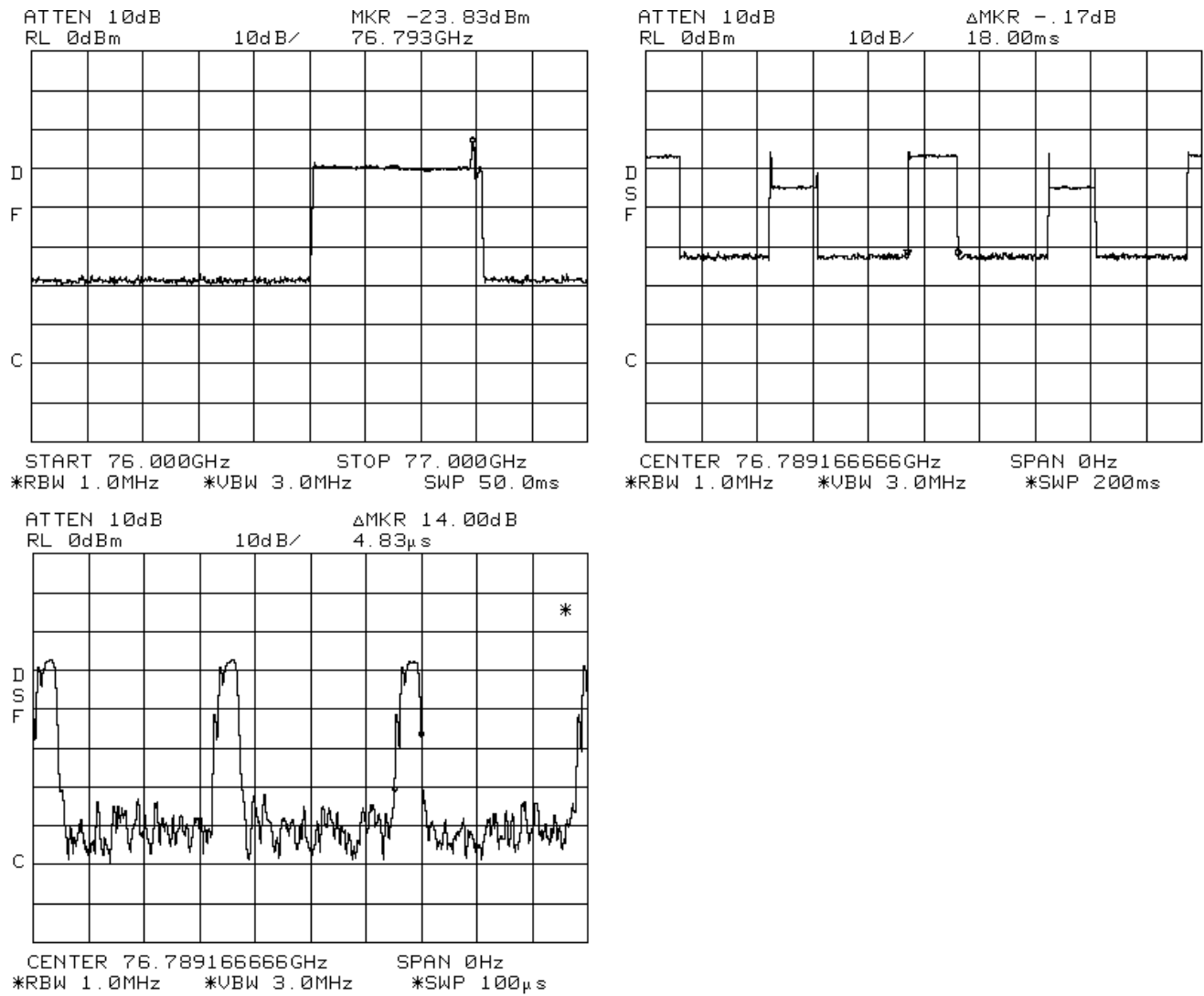

Figure 5(a): Pulsed Emission Characteristics (Duty Cycle).

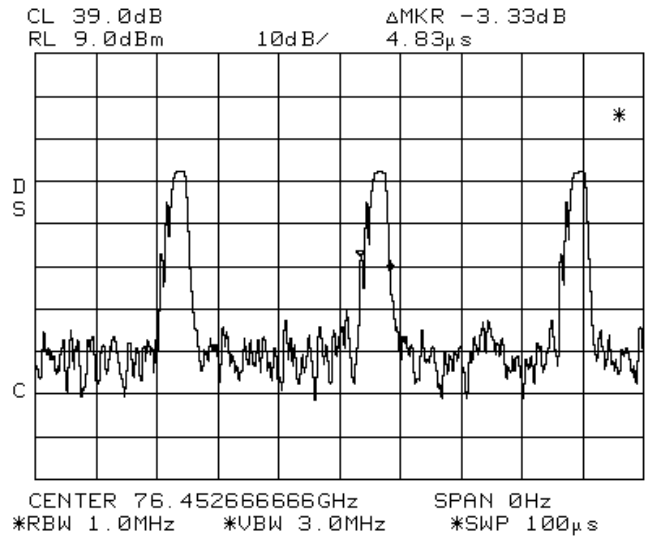
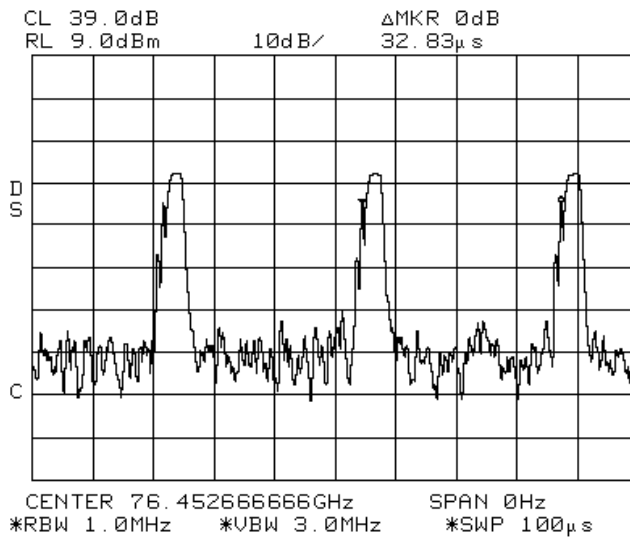
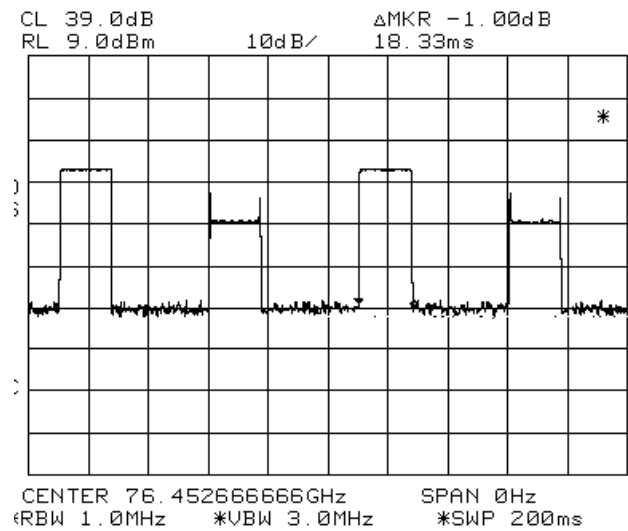
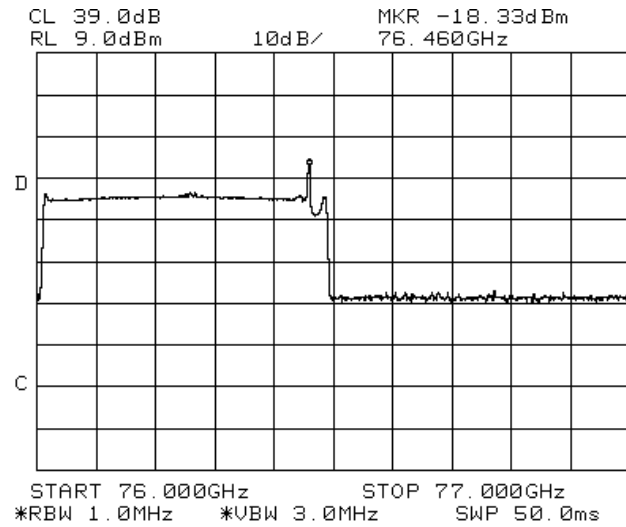

Figure 5(b): Pulsed Emission Characteristics (Duty Cycle).

### 3.2.2 Fundamental Emission Bandwidth

Emission bandwidth (EBW) of the EUT is measured with the device placed in the worst case test mode. Radiated emissions are recorded following the test procedures listed in Section 1.1. The 20 dB EBW is measured as the max-held peak-detected signal when the IF bandwidth is greater than or equal to 1% of the receiver span. For complex modulations other than ASK and FSK, the 99% emission bandwidth per IC test procedures has a different result, and is also separately reported. The results of EBW testing are summarized in Table 4. Plots showing measurements employed to obtain the emission bandwidth reported are provided in Figure 6.

Table 4: Intentional Emission Bandwidth.

<b>Frequency Range</b> Freq > 1 GHz	<b>Det</b> Pk	<b>IFBW</b> 1 MHz	<b>Test Date:</b> 16-Nov-14
	<b>VBW</b> 3 MHz	<b>Span</b> 1200 MHz	<b>Test Engineer:</b> Valdis V. Liepa
			<b>EUT</b> Delphi SRR2 77GHz
			<b>Meas. Distance:</b> 1 m

Occupied Bandwidth					
Transmit Mode	Temperature ( C )	Voltage (V)	26dB OBW (MHz)	OBW Limit (MHz)	Notes/Pass/Fail
LR Low	20.0	13.4	313.0	1000.0	subfigure (a)
LR Mid	20.0	13.4	308.0	1000.0	subfigure (a)
LR High	20.0	13.4	307.0	1000.0	subfigure (a)
MR Low	20.0	13.4	483.0	1000.0	subfigure (b)
MR High	20.0	13.4	477.0	1000.0	subfigure (b)
Maximum OBW			<b>483.0</b>	1000.0	Pass

Equipment Used: HP8560E1, HP8593E1, HP11970W1, WBAND1

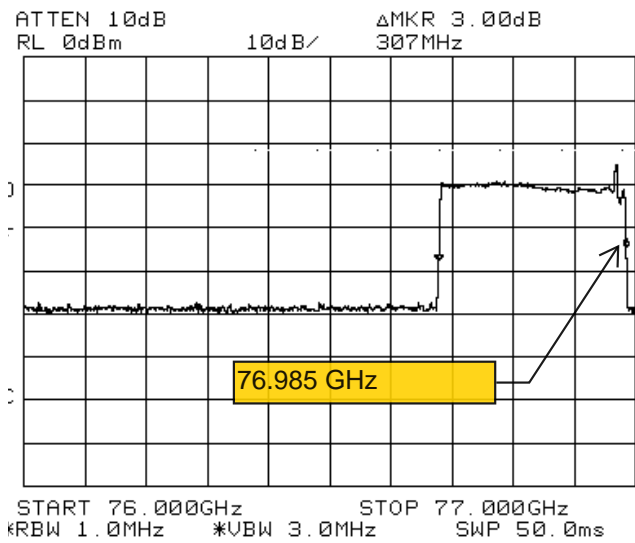
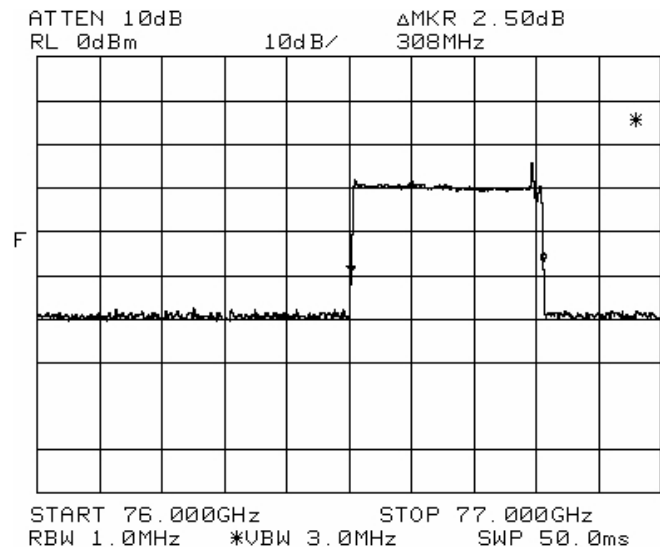
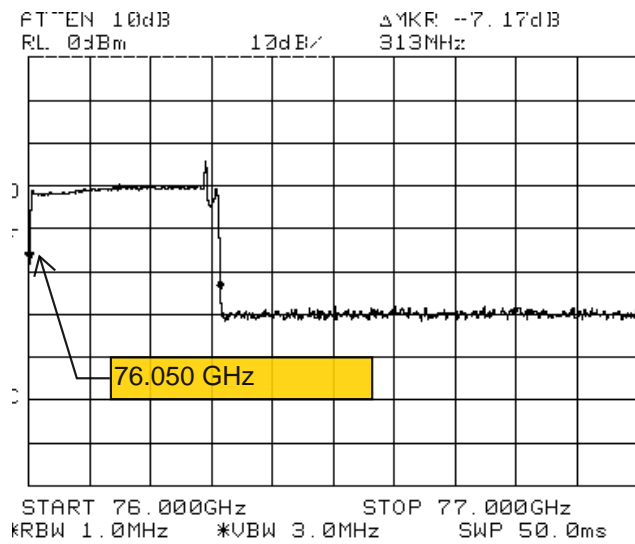

Figure 6(a): Intentional Emission Bandwidth.



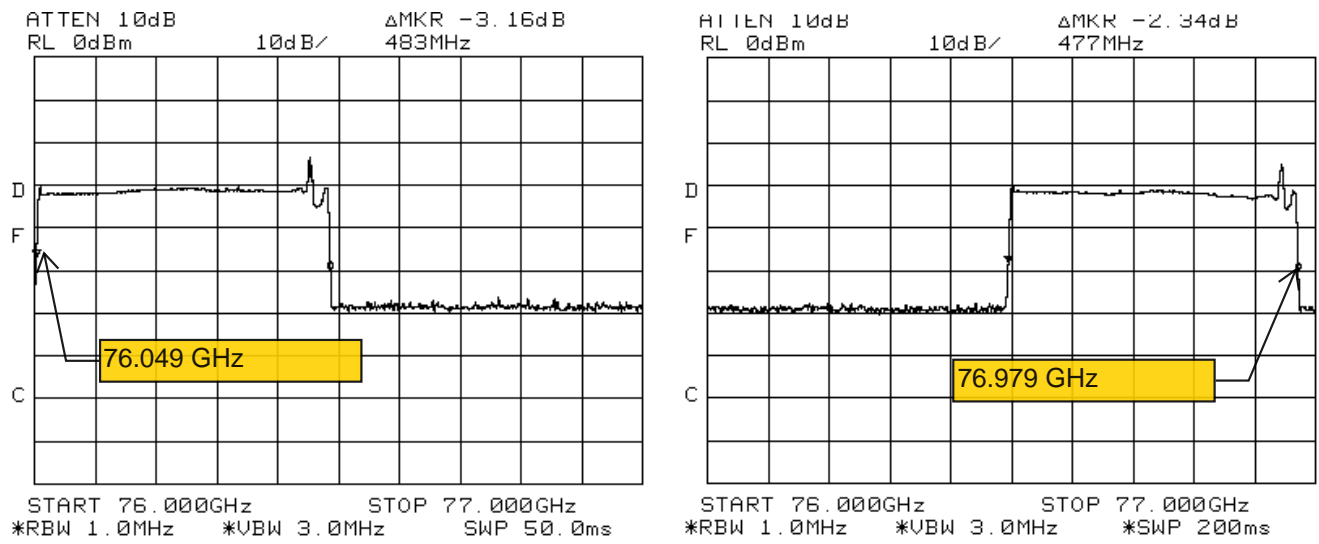

Figure 6(b): Intentional Emission Bandwidth.

### 3.2.3 Fundamental Emission

Following the test procedures listed in Section 1.1, radiated emissions measurements are made on the EUT for both Horizontal and Vertical polarized fields. Table 5 details the results of these measurements.

Table 5: Fundamental Radiated Emissions.

<b>Frequency Range</b>	<b>Det</b>	<b>IF Bandwidth</b>	<b>Video Bandwidth</b>	<b>Test Date:</b>	30-Oct-14
25 MHz f 1 000 MHz	Pk/QPk	120 kHz	300 kHz	<b>Test Engineer:</b>	Valdis V. Liepa
f > 1 000 MHz	Pk	1 MHz	3 MHz	<b>EUT:</b>	Delphi SRR2 77GHz
f > 1 000 MHz	Avg	1 MHz	10 kHz	<b>Mode:</b>	CW
				<b>Meas. Distance:</b>	See Table.

#	Env.		Frequency Band		Type	Antenna + Cable				Rx. Power		Range Correction <sup>(1)</sup>				E3-Field		EIRP <sup>(3)</sup>		S3 <sup>(5)</sup>		FCC S3 Limit		IC S3 Limit <sup>(6)</sup>			Pass By	Comments
	Temp. (C)	Volt. (V)	Start MHz	Stop MHz		Pol.	Dim. <sup>(4)</sup> cm	Ka dB/m	Kg dB	Pk dBm	Avg <sup>(1)</sup> dBm	MR m	DR m	N/F	CF dB	Pk dBuV/m	Avg dBuV/m	Pk dBm	Avg dBm	Pk dBm/cm2	Avg dBm/cm2	Pk dBm/cm2	Avg dBm/cm2	FWD dBm/cm2 (Avg)	SIDE dBm/cm2	STA dBm/cm2		
1	20	13.4	76293.0	76293.0	Horn W	H/V	4.0	45.3	0.0	-34.6	-47.4	3.0	3.0	0.8	0.0	117.7	104.9	22.5	9.7	-38.0	-50.8	-5.5	-10.6	-12.2	-15.2	-37.0	13.8	LOW LR CHANNEL
2	20	13.4	76788.0	76788.0	Horn W	H/V	4.0	45.3	0.0	-35.9	-48.7	3.0	3.0	0.8	0.0	116.4	103.6	21.2	8.4	-39.3	-52.1	-5.5	-10.6	-12.2	-15.2	-37.0	15.1	MID LR CHANNEL
3	20	13.4	76969.0	76969.0	Horn W	H/V	4.0	45.3	0.0	-36.4	-49.2	3.0	3.0	0.8	0.0	115.9	103.1	20.7	7.9	-39.8	-52.6	-5.5	-10.6	-12.2	-15.2	-37.0	15.6	HIGH LR CHANNEL
4																												
5	20	13.4	76453.0	76453.0	Horn W	H/V	4.0	45.3	0.0	-35.3	-48.0	3.0	3.0	0.8	0.0	117.1	104.3	21.9	9.1	-38.7	-51.5	-5.5	-10.6	-12.2	-15.2	-37.0	14.5	LOW MR CHANNEL
6	20	13.4	76944.0	76944.0	Horn W	H/V	4.0	45.3	0.0	-36.5	-49.3	3.0	3.0	0.8	0.0	115.8	103.0	20.6	7.8	-39.9	-52.7	-5.5	-10.6	-12.2	-15.2	-37.0	15.7	HIGH MR CHANNEL
7																												

- (1) Avg. is computed from the Peak measurement via the worst-case Spread Duty Cycle detailed in the Duty Cycle section of this test report.
- (2) CF is computed assuming a 40 dB/decade Near-Field Decay Rate and a 20 dB/Decade Far-field Decay Rate. DR is Regulatory Range Distance. MR is Measurement Distance. N/F is near-far boundary.
- (3) EIRP is computed from field strength at 3 meter distance. If emission is within 6 dB of regulatory limit, then substitution method measurement is employed to determine exact EIRP.
- (4) Dimension of antenna is taken to be the larger of the test antenna and the DUT antenna; DUT antenna is 4cm in dimension.
- (5) Spacial Power Density S @ 3m (dBm/cm<sup>2</sup>) = EIRP (dBm) - 10\*log10(4\*pi\*(300cm)^2) = EIRP (dBm) - 60.5 dB
- (6) Industry Canada S3 Limit for fundamental is 60uW/cm<sup>2</sup> (-12.2 dBm) for forward looking, 30 uW/cm<sup>2</sup> (-15.2 dBm) for side looking, and 200nW/cm<sup>2</sup> (-37.0 dBm) for stationary radars.

#	Temp. (C)	Freq. MHz	Pr (dBm)	Volt. (V)	Freq. MHz	Pr (dBm)
8				18.0	76789.0	-35.9
9	55	76500.38	-38.0		76789.0	-35.8
10	20	76499.90	-35.9	14.0	76789.0	-35.9
11	.0	76500.00	-36.0	12.0	76789.0	-35.9
12	-20	76501.10	-35.8	10.0	76789.0	-36.0
13				8.0	76789.0	-35.9
14				6.0	76790.0	-35.7
15						
16						
17						
18						
19						

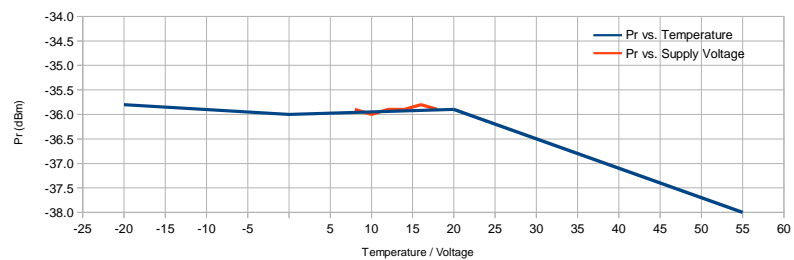

Equipment Used: HP8560E1, HP8593E1, HP11970W1, WBAND1

### 3.2.4 Exposure and Potential Health Hazard

To demonstrate compliance with with regulations that place limitations on human electromagnetic field exposure for both the general public and for workers, we measured localized field strength in close proximity to the EUT. These levels are compared with limits placed by the directives and recommendations detailed in Section 1.1. Table 6 details the results of these computations.

Table 6: Electromagnetic Field Exposure.

		Level	Units			Test Date:	30-Oct-14		
MPE Field Strength Limit		61	V/m			Test Engineer:	Valdis V. Liepa		
MPE Power Density Limit		1.0	mW/cm2			EUT Mode:	CW		
						Meas. Distance:	3m		
Freq.	Temp	EIRP (Pk)	Exposure Duty	EIRP (Avg)	EUT Ant. Dim.	Far-field Distance	S = 1mW/cm2 Dist.*	S @ 20 cm Distance	Comments
MHz	°C	dBm	dB	dBm	cm	m	cm	mW/cm2	
76293	20	22.5	-4.4	18.1	4.00	0.81	1.2	0.013	LOW LR CHANNEL
76788	20	21.2	-4.4	16.8	4.00	0.82	1.2	0.009	MID LR CHANNEL
76969	20	20.7	-4.4	16.3	4.00	0.82	1.1	0.008	HIGH LR CHANNEL
76453	20	21.9	-4.4	17.4	4.00	0.82	1.2	0.011	LOW MR CHANNEL
76944	20	20.6	-4.4	16.2	4.00	0.82	1.1	0.008	HIGH MR CHANNEL

$$S @ 20\text{cm} = \text{EIRP} - 10 * \log_{10}(4 * \pi * 20^2)$$

$$S = 1\text{mW/cm}^2 \text{ Distance} = \sqrt{30 * (\text{EIRP}(\text{Avg})/1000)} / 61 * 100$$

S = 1mW/cm2 Distance is an overestimated value(when less than the DUT far field distance, and demonstrates compliance with FCC Part 1.1307, 1.1310, 2.1091, and 2.0193 requirements when the DUT is mounted into the motor vehicle.

### 3.3 Unintentional Emissions

#### 3.3.1 Transmit Chain Spurious Emissions

The results for the measurement of transmit chain spurious emissions at the nominal voltage and temperature are provided in Table 7.

Table 7: Transmit Chain Spurious Emissions.

<b>Frequency Range</b>	<b>Det</b>	<b>IF Bandwidth</b>	<b>Video Bandwidth</b>	<b>Test Date:</b>	10/30/14
25 MHz f 1 000 MHz	Pk/QPk	120 kHz	300 kHz	<b>Test Engineer:</b>	Valdis V. Liepa
f > 1 000 MHz	Pk	1 MHz	3 MHz	<b>EUT:</b>	Delphi SRR2 77GHz
f > 1 000 MHz	Avg	1 MHz	10 kHz	<b>Mode:</b>	Modulated
				<b>Meas. Distance:</b>	See Table.

FREQ < 40 GHZ																										
#	Env.		Frequency Band		Antenna + Cable***				Rx. Power		Range Correction*				E-Field @ DR		EIRP*		S @ DR		E-Field Limit		Pass By	Comments		
	Temp. (C)	Volt. (V)	Start MHz	Stop MHz	Type	Pol. H/V	Dim. cm	Ka dB/m	Kg dB	Pk dBm	Avg dBm	MR m	DR m	N/F m	CF dB	Pk dBuV/m	Avg dBm	Pk dBm/cm2	Avg dBm/cm2	Pk dBm/cm2	Avg dBm/cm2					
1																										
2																										
3			THE EUT EMPLOYS NO INTERNAL OSCILLATORS OR CRYSTALS BELOW 40 GHZ RELATED TO THE RF CHAIN (TX OR RX) FOR THE DEVICE. THE EUT IS PHASE LOCKED FROM A 25 MHZ CRYSTAL. ANY EMISSIONS BELOW 40 GHZ WOULD BE NON-RF RELATED (DIGITAL) EMISSIONS WHICH ARE EXEMPT FOR VEHICULAR MOUNTED APPLICATIONS.																							
4																										
5																										
6																										
FREQ >= 40 GHZ																										
#	Env.		Frequency Band		Antenna + Cable***				Rx. Power		Range Correction*				E-Field @ DR		EIRP*		S @ DR		FCC S Limit		IC S Limit		Pass By	Comments
	Temp. (C)	Volt. (V)	Start GHz	Stop GHz	Type	Pol. H/V	Dim. cm	Ka dB/m	Kg dB	Pk dBm	Avg dBm	MR m	DR m	N/F m	CF dB	Pk dBuV/m	Avg dBm	Pk dBm/cm2	Avg dBm/cm2	Pk dBm/cm2	Avg dBm/cm2	FWD dBm/cm2	SIDE dBm/cm2	Avg dBm/cm2		
7	20	13.4	40.0	60.0	Horn U	H/V	6.3	39.1	0.0	-61.2		0.30	3.0	1.6	-34.5	50.4		-44.8		-105.3		-62.2	-62.2	-65.2	40.1	LMH LR+MR Channels (max all)
8	20	13.4	50.0	75.0	Horn V	H/V	4.0	40.1	0.0	-60.5		0.30	3.0	0.8	-28.5	58.1		-37.1		-97.7		-62.2	-62.2	-65.2	32.4	LMH LR+MR Channels (max all)
9	20	13.4	75.0	76.0	Horn W	H/V	4.0	45.3	0.0	-57.0	-70.0	0.30	3.0	0.8	-28.6	66.7	53.7	-28.5	-41.5	-89.1	-102.1	-62.2	-62.2	-65.2	23.8	LR Low CH (low band edge)
10	20	13.4	77.0	110.0	Horn W	H/V	4.0	46.4	0.0	-52.3	-69.3	0.30	3.0	1.2	-31.8	69.3	52.3	-25.9	-42.9	-86.5	-103.5	-62.2	-62.2	-65.2	21.3	LR Low CH (high band edge)
11	20	13.4	75.0	76.0	Horn W	H/V	4.0	45.3	0.0	-57.3	-71.0	0.30	3.0	0.8	-28.6	66.4	52.7	-28.8	-42.5	-89.4	-103.1	-62.2	-62.2	-65.2	24.1	LR Mid CH (low band edge)
12	20	13.4	77.0	110.0	Horn W	H/V	4.0	46.4	0.0	-55.6	-70.8	0.30	3.0	1.2	-31.8	66.0	50.8	-29.2	-44.4	-89.8	-105.0	-62.2	-62.2	-65.2	24.6	LR Mid CH (high band edge)
13	20	13.4	75.0	76.0	Horn W	H/V	4.0	45.3	0.0	-56.2	-70.5	0.30	3.0	0.8	-28.6	67.5	53.2	-27.7	-42.0	-88.3	-102.6	-62.2	-62.2	-65.2	23.0	LR High CH (low band edge)
14	20	13.4	77.0	110.0	Horn W	H/V	4.0	46.4	0.0	-54.9	-69.3	0.30	3.0	1.2	-31.8	66.7	52.3	-28.5	-42.9	-89.1	-103.5	-62.2	-62.2	-65.2	23.9	LR High CH (high band edge)
15	20	13.4	75.0	76.0	Horn W	H/V	4.0	45.3	0.0	-57.5	-69.7	0.30	3.0	0.8	-28.6	66.2	54.0	-29.0	-41.2	-89.6	-101.8	-62.2	-62.2	-65.2	24.3	MR Low CH (low band edge)
16	20	13.4	77.0	110.0	Horn W	H/V	4.0	46.4	0.0	-55.9	-69.4	0.30	3.0	1.2	-31.8	65.7	52.2	-29.5	-43.0	-90.1	-103.6	-62.2	-62.2	-65.2	24.9	MR Low CH (high band edge)
17	20	13.4	75.0	76.0	Horn W	H/V	4.0	45.3	0.0	-58.0	-69.9	0.30	3.0	0.8	-28.6	65.7	53.8	-29.5	-41.4	-90.1	-102.0	-62.2	-62.2	-65.2	24.8	MR High CH (low band edge)
18	20	13.4	77.0	110.0	Horn W	H/V	4.0	46.4	0.0	-56.4	-68.6	0.30	3.0	1.2	-31.8	65.2	53.0	-30.0	-42.2	-90.6	-102.8	-62.2	-62.2	-65.2	25.4	MR High CH (high band edge)
19	20	13.4	110.0	140.0	Horn G	H/V	4.0	54.0	0.0	-58.5	-74.0	0.30	3.0	1.5	-33.9	68.6	53.1	-26.6	-42.1	-87.2	-102.7	-62.2	-62.2	-65.2	22.0	LMH LR+MR Channels (max all)
20	20	13.4	140.0	200.0	Horn G	H/V	4.0	54.0	0.0	-62.4	-74.4	0.30	3.0	2.1	-37.0	61.6	49.6	-33.6	-45.6	-94.2	-106.2	-62.2	-62.2	-65.2	28.9	LMH LR+MR Channels (max all)
21	20	13.4	200.0	231.0	Horn G	H/V	4.0	54.0	0.0	-65.3	-72.7	0.30	3.0	2.5	-38.3	57.4	50.0	-37.8	-45.2	-98.3	-105.7	-60.0	-60.0	-60.0	38.3	LMH LR+MR Channels (max all)
22																										

\* CF is computed assuming a 40 dB/decade Near-Field Decay Rate and a 20 dB/Decade Far-field Decay Rate. DR is Regulatory Range Distance. MR is Measurement Distance.  
 \*\* EIRP is computed from field strength at 3 meter distance. If emission is within 6 dB of regulatory limit, then substitution method measurement is employed to determine exact EIRP.  
 \*\*\* Dimension of antenna is taken to be larger of the test antenna and the DUT antenna; DUT antenna is 4cm in dimension.

Equipment Used: HP8560E1, HP8593E1, HP11970W1, GBAND1, WBAND1, UBAND1, KABAND1, KBAND1, XBAND1, XNBAND1, CBAND1, UMRH1, AVAMP2, AVAMP3