

Installing the FM Coupler in your vehicle

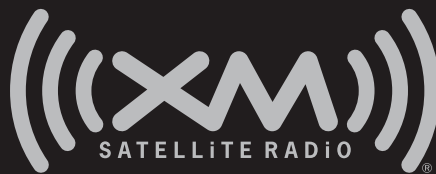

FCC Information

Please note that the CLA cable supplied with your device includes permanently attached ferrite beads at each end. It is the responsibility of the user to use the cable with the ferrite beads.

The user is cautioned that changes or modifications not expressly approved by XM Satellite Radio, Inc. can void the user's authority to operate this device.

This device complies with Part 15 of the FCC Rules. Operation is subject to the following two conditions: (1) This device may not cause harmful interference, and (2) this device must accept any interference received, including interference that may cause undesired operation.

This equipment has been tested and found to comply with the limits for a Class B digital device, pursuant to Part 15 of the FCC Rules. These limits are designed to provide reasonable protection against harmful interference in a residential installation.

This equipment generates, uses and can radiate radio frequency energy and, if not installed and used in accordance with the instructions, may cause harmful interference to radio communications. However, there is no guarantee that interference will not occur in a particular installation. If this equipment does cause harmful interference to radio or television reception, which can be determined by turning the equipment off and on, the user is encouraged to try to correct the interference by one or more of the following measures:

- Reorient or relocate the receiving antenna.
- Increase the separation between the equipment and receiver.
- Connect the equipment into an outlet on a circuit different from that to which the receiver is connected.
- Consult the dealer or an experienced radio/TV technician for help.

Contents

Installing the FM Coupler Overview	4
Installation Locations	5
Installation Setup	6
External FM Whip Antenna Routing	8
Internal On Glass Antenna Routing	12

Installing the FM Coupler Overview

To install the FM Coupler, first find a suitable location that works in your vehicle. You need to determine the location of your vehicle's FM Antenna and properly routing the FM Coupler cables to your FM antenna..

Your vehicle's FM antenna will be located in one of seven common locations:

1. front fender
2. rear fender
3. roof top front
4. roof top rear
5. adhered on edges of windshield
6. adhered on top of rear window
7. adhered on rear side glass (in some SUVs)

For best audio performance, install the FM Coupler by either clipping it directly to an external whip antenna (locations 1 through 4) or against an interior on-glass antenna using the additional window Contact Bracket (locations 5 through 7). Step by step installation instructions are provide later in this document.

Installation Locations

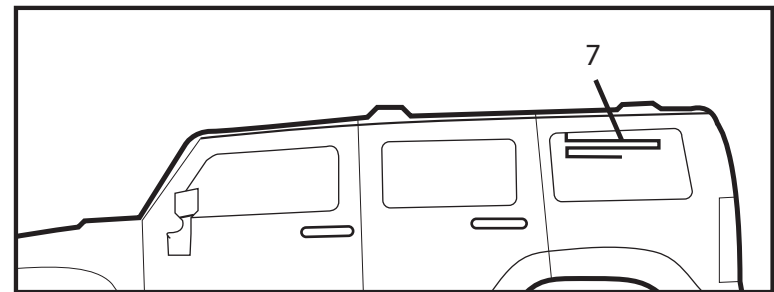
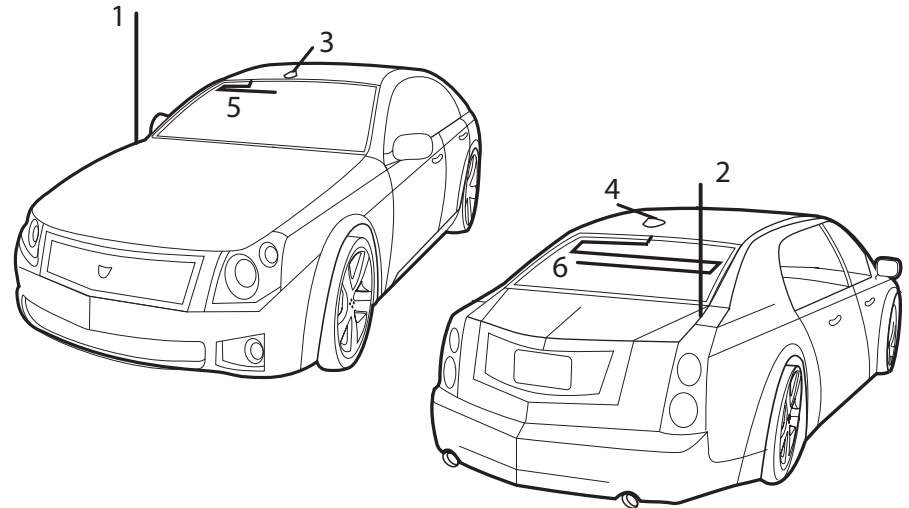

Installation Setup

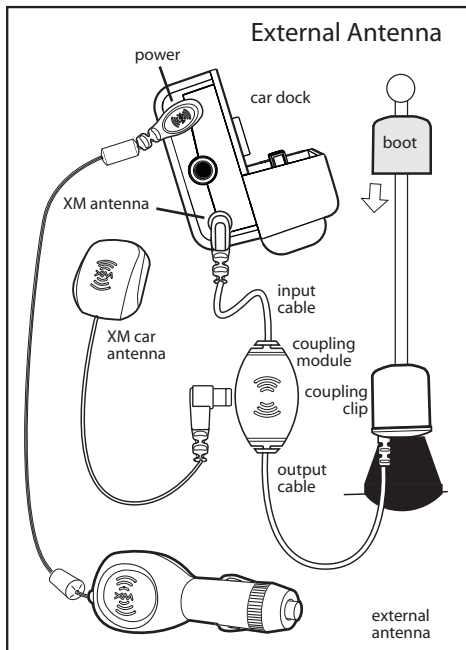

6

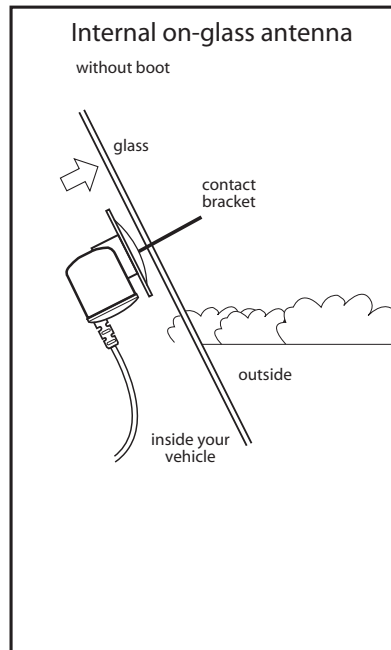

Installation Setup

The following steps will guide you through the installation of your FM Coupler

1. Install your XM Radio and vehicle kit as described in your XM Radio User's Manual but leave the XM antenna disconnected from the dock.
2. Locate your vehicle's FM antenna and determine the best routing method to get the FM Coupler output cable to the FM antenna. (For external whip antennas, the Coupling Clip needs to be routed outside of the vehicle. For internal on-glass antennas, all routing is inside the passenger compartment and the Contact Bracket is used.)
3. Connect the FM Coupler input cable to the vehicle dock antenna input.
4. Connect the XM Antenna to the FM Coupler antenna input, located on the coupler module about 2 feet from the end of the input cable. Tuck away any excess input cable and the coupler module behind dash or other hidden location for a clean installation.
5. Route the output cable with Coupling Clip to your vehicle FM antenna. (This guide assumes you have already installed your XM antenna per the instructions in your XM radio user guide. The position of the XM antenna in the illustration below is for example only. There is no need to change your XM antenna installation.)

Note: When routing the FM Coupler cable use pre-existing wire channels whenever possible to avoid loose wires on the interior of the vehicle which are susceptible to damage and to maintain a professional looking installation. Route cable carefully by taking notice of how doors open and close, as well as how seats move when they are adjusted so you can be certain there is ample clearance provided for the cable.

Avoid inadvertent damage that may be caused by kinking, crimping, twisting or chafing the cables. Secure and tie wrap the excess cable under your dash board, between the seat and the console, or on the floor under a seat or floor mat. Securing the excess cable will help to prevent it from interfering with the everyday use of your vehicle, improve the appearance of the installation, and avoid any undesirable accidental damage to the cables that might result in loss of satellite signal or FM Coupler performance.

7

External FM Whip Antenna Routing

For a whip antenna in the front, route the output cable under the dash or carpet to the door jam and outside as shown in the illustration. Route the cable across the weather seal near the bottom of the door to reduce water leaks.

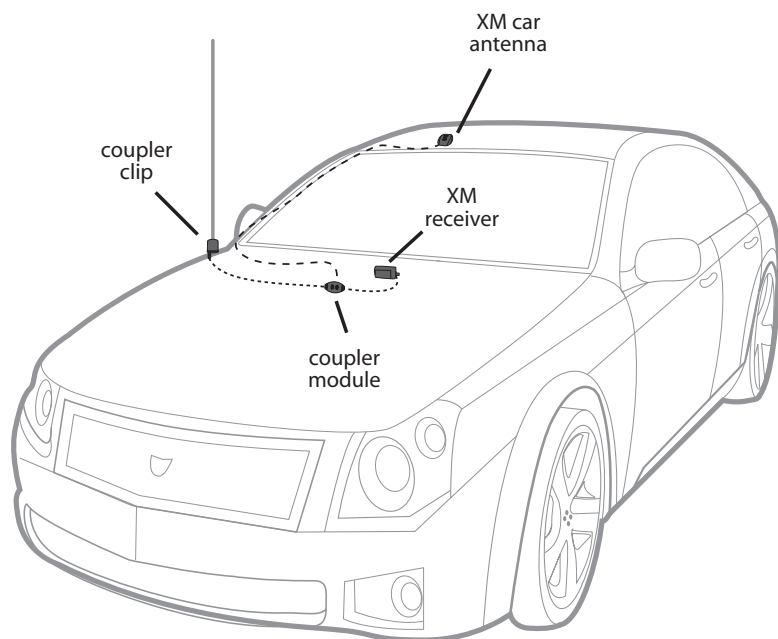

8

External FM Whip Antenna Routing

For a whip antenna in the rear, route the output cable along the floor under the door jam trim or under the carpet to the rear of the passenger compartment as shown in the illustration below. Route the cable into the trunk through available wire channels and out of the trunk to the external whip antenna. Always cross the weather seal at the lowest part of the trunk to reduce water leaks.

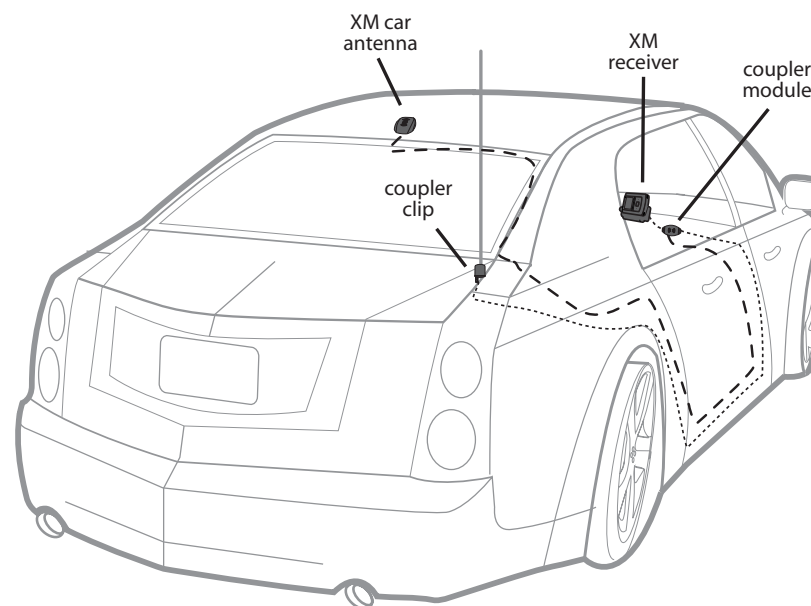

9

External FM Whip Antenna Routing

6. After routing the cable, if you have an external whip or roof mount FM antenna, attach the Coupling Clip directly to the base of the antenna as illustrated below. Cover the Clip with the rubber boot provided to protect and secure the clip. Secure the cable inside the trunk or hood to avoid interference or accidental damage.

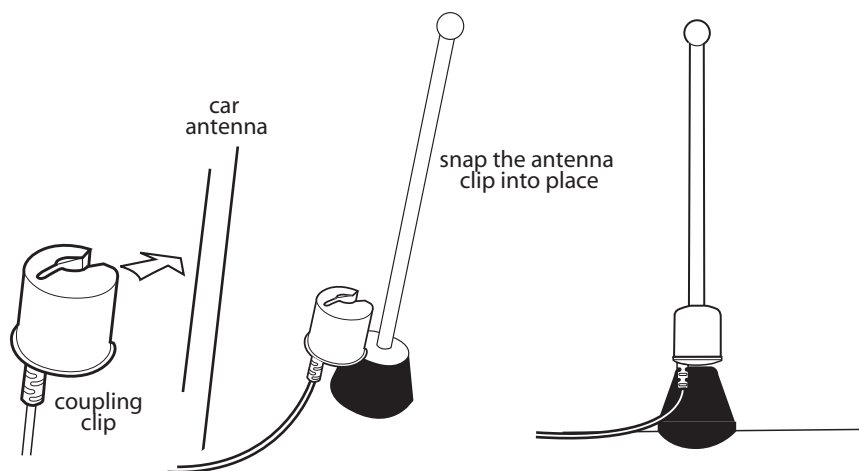

External FM Whip Antenna Routing

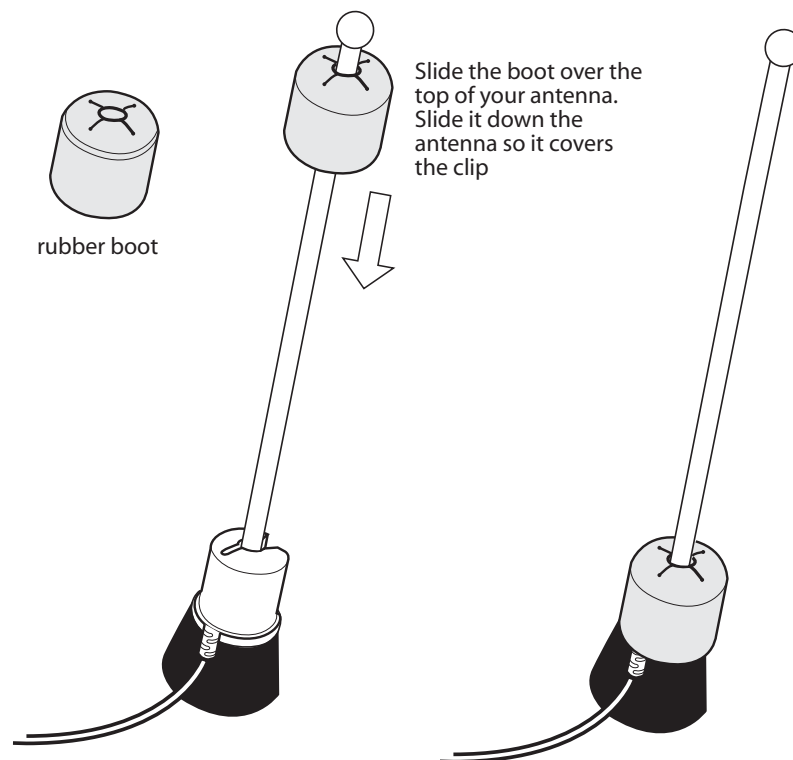

Internal On Glass Antenna Routing

For an on glass antenna in the front, route the output cable under the dash or along the floor and up to the window liner along the window edge up to the on glass antenna element.

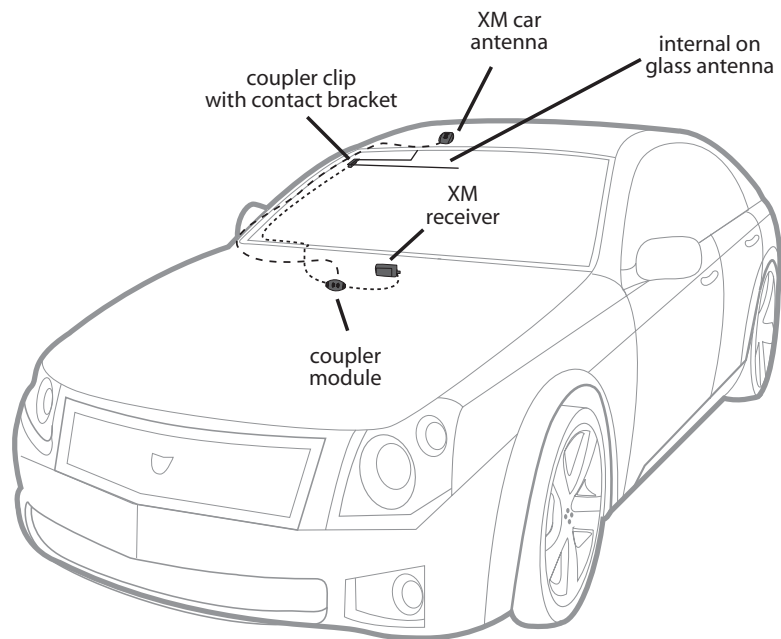

Internal On Glass Antenna Routing

For an on glass antenna in the rear, route the output cable along the floor under the door jam trim or under the carpet to the rear of the passenger compartment then up to the window liner along the window edge up to the one glass antenna element, as shown in the illustration below.

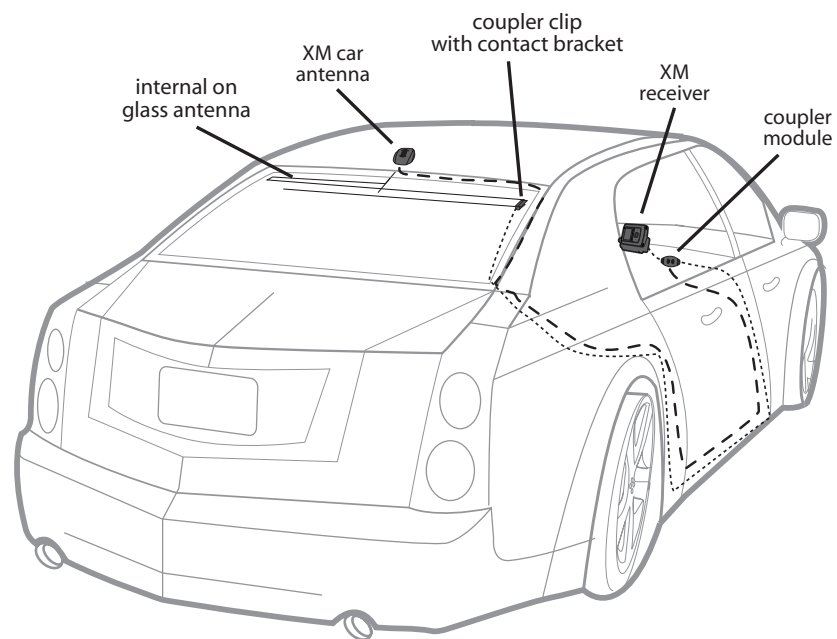

Internal On Glass Antenna Routing

7. If you have an on glass FM antenna, install the Contact Bracket on the interior window surface over the antenna element using the adhesive pad provided and the following steps. It may be mounted either vertical or horizontal depending on the portion of the antenna element most easily accessed. Select a bracket position that allows room to attach the Coupling Clip and cleanly run cables.
 - a. Clean the mounting location on the glass for the Contact Bracket with the included surface preparation kit.
 - b. The Contact Bracket has alignment arrows on the side opposite the adhesive pads. These arrows indicate the contact strip location on the base of the bracket. Align the arrows with the on glass antenna element to ensure you make direct contact between the strip and the antenna element.
 - c. Remove the red liner from the adhesive pad and press the Contact Bracket firmly at the identified mounting location on the glass. You can also view the alignment through the glass from outside the vehicle.
 - d. Once the Bracket is in place, attach the Coupling Clip to the flange on the Bracket and route any excess cable behind liners for a clean look.

Internal On Glass Antenna Routing

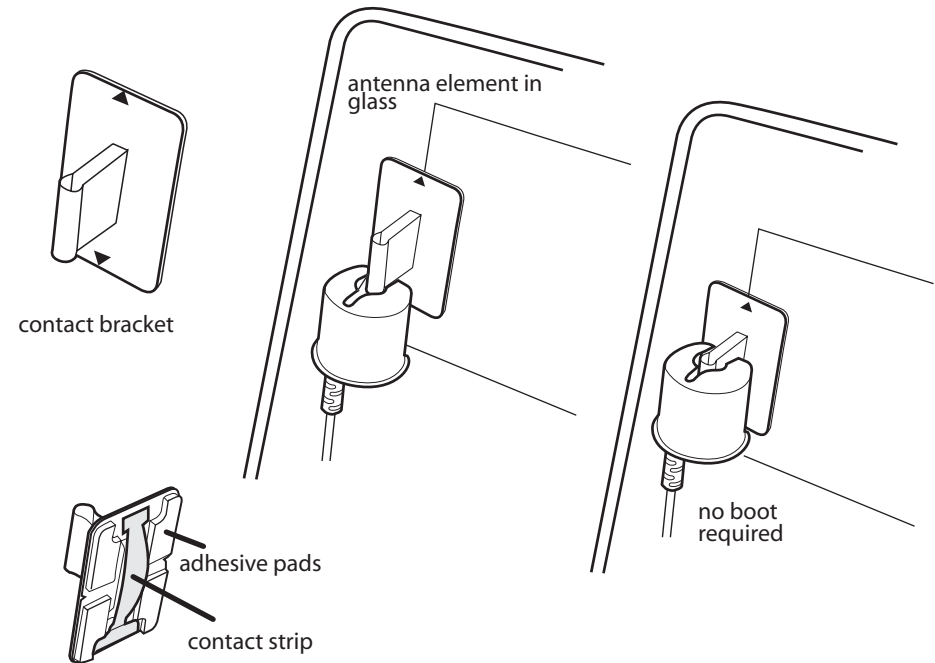

Internal On Glass Antenna Routing

CAUTION: Do not connect the contact bracket to the rear defogger elements. In some vehicles they look similar to the FM Antenna.

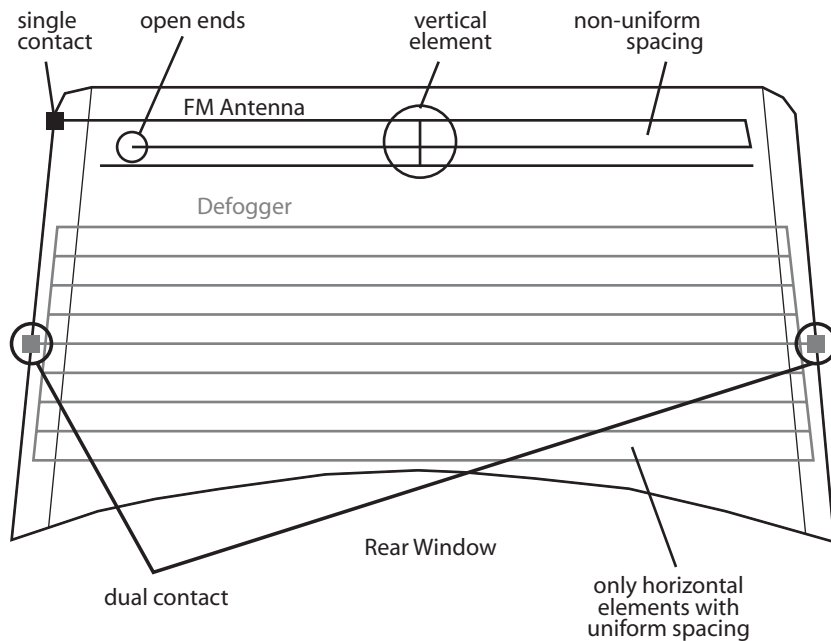

Internal On Glass Antenna Routing

You can distinguish the FM Antenna Elements from the Defogger Elements by several key features.

1. The FM antenna is typically found on the top 6 to 8 inches of the rear window and the Defogger is below.
2. The FM antenna has open ends (connected to nothing) and the Defogger does not.
3. The FM antenna can have vertical and horizontal (or even diagonal) with non-uniform line spacing. The Defogger has all horizontal lines of uniform spacing.
4. The FM antenna will have a single contact point and the Defogger will have two, which are typically on opposite sides of the window. (The contact points may be hidden behind interior liners or exterior glass tinting but the key is to locate where the elements go off the window edge. The FM antenna will have only one location where the defogger can have two or more.)

