



# DELPHI

## Delphi XM Satellite Radio Signal Repeater User Guide

For Use With Any Delphi XM Satellite  
Radio Unit Home Kit or Audio System

SA10116-11B1



**Caution:** The Delphi XM Satellite Radio Signal Repeater operates on a 900 MHz frequency and may cause interference with other wireless equipment. For best results, do not operate the Delphi XM Satellite Radio Signal Repeater in the vicinity of other equipment operating at this frequency. (See page 9 for more information.)

**Caution:** This manual contains important safety and operating information. Please read and follow the instructions in this manual. Failure to do so could result in damage to your audio system, your home, and/or other property.

This device complies with Part 15 of the FCC rules. Operation is subject to the following two conditions:

1. This device may not cause harmful interference, and
2. This device must accept any interference received, including interference that may cause undesired operation.

**IMPORTANT:** The FCC and FAA have not certified the Delphi XM<sup>®</sup> Satellite Radio Signal Repeater for use in any aircraft (neither portable nor permanent installation). Therefore, Delphi cannot support this type of application or installation.

## FCC Statement

This equipment has been tested and found to comply with the limits for a Class B digital device, pursuant to Part 15 of the FCC rules. These limits are designed to provide reasonable protection against harmful interference in a normal installation. This equipment generates, uses, and can radiate radio frequency energy and, if not installed and used in accordance with the instructions, may cause harmful interference to radio communications. However, there is no guarantee that interference will not occur in a particular installation. If this equipment does cause harmful interference to radio or television reception, which can be determined by turning the equipment off and on, the user is encouraged to try to correct the interference by one or more of the following measures:

- Find another location for the repeater antenna (this is the smaller product of the two).
- Move the transmitter and the repeater antenna farther away from each other.
- Try not to share one power outlet for the transmitter and the repeater antenna.
- Consult your dealer or an experienced electronics technician for help.

**Caution:** Modifications not expressly approved by the manufacturer could void the user's authority to operate the equipment under FCC rules.

# Signal Repeater Overview

introduction iii

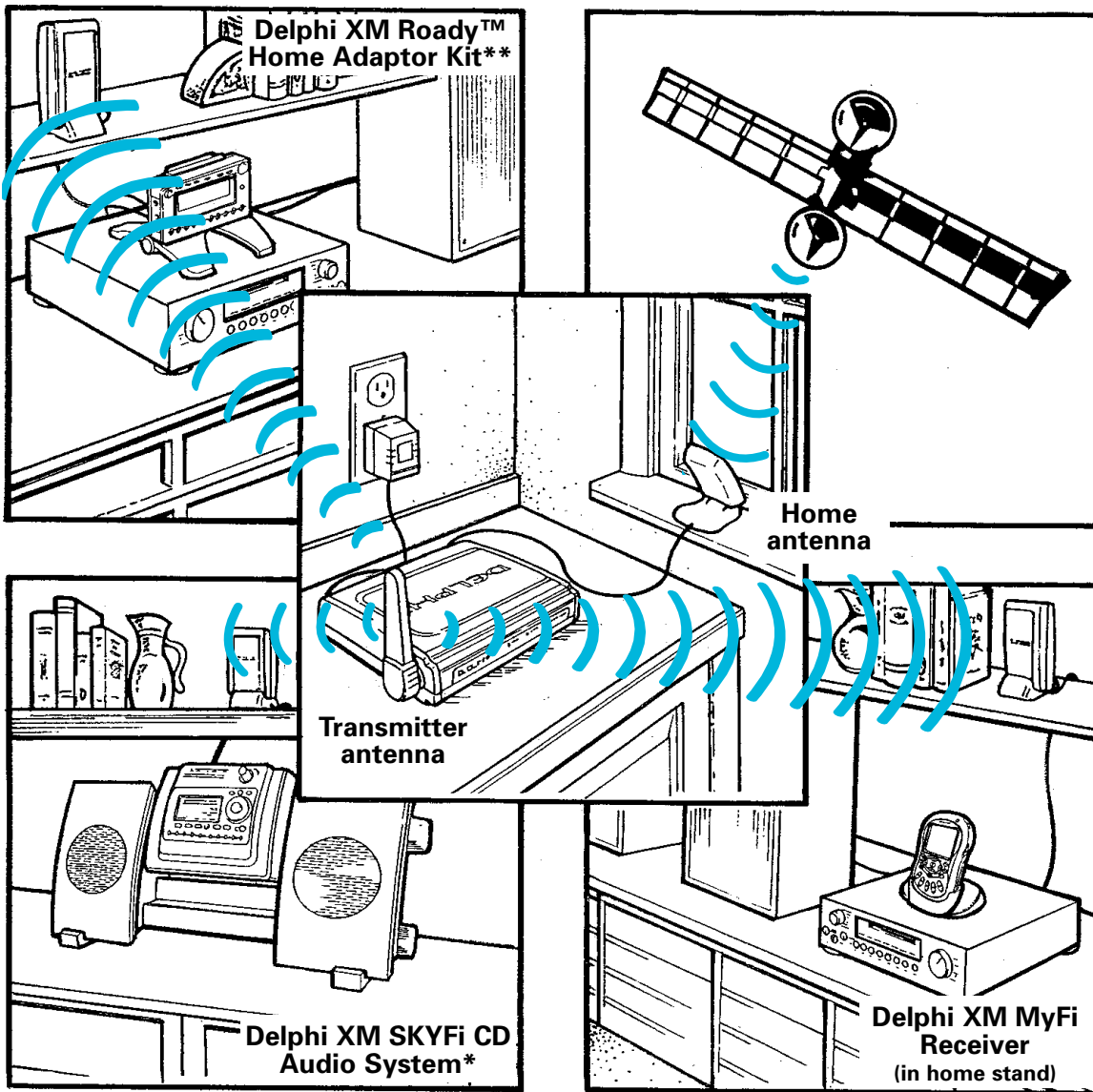

Also for use with Delphi XM SKYFi Audio System\*  
and Delphi XM SKYFi Home Adaptor Kit.\*

\*For use with either SKYFi or SKYFi2.  
\*\*For use with either Roady or Roady2.

# Welcome

Thank you for purchasing a Delphi XM Satellite Radio Signal Repeater. The Signal Repeater eliminates the need for long and unsightly antenna extensions by retransmitting the XM signal received from the satellite up to 75 feet, providing you better access to more than 150 channels of music, news, and information, even in homes and offices where it's not easy to locate the antenna near a window with direct access to the satellites. Plus, it allows multiple receivers located in a home or office to share a single XM antenna and signal. (Additional repeater antennas [SA10117-11P1] are available for purchase separately.)

Your Delphi XM Satellite Radio Signal Repeater must be used with the enclosed connecting devices to ensure maximum performance and **safety**.

---

**Additional hardware and XM subscription required for reception. Not available in Alaska or Hawaii. Satellite radio reception may vary or could potentially be degraded by satellite signal obstruction.**

---

**Caution:** Do not modify or alter wires or connections in any way. Shortening wires or connections may prevent proper functioning of the protection circuit. Doing so may damage your unit and will void your warranty.

**Caution:** When using the Delphi XM Satellite Radio Signal Repeater, follow the proper safety procedures in your receiver's manual. Not doing so could result in damage to your Signal Repeater, other accessories, and/or other property. Copies of Delphi satellite radio receiver user guides are available at [www.shopdelphi.com](http://www.shopdelphi.com).

## About the Delphi XM Satellite Radio Signal Repeater

The Delphi XM Satellite Radio Signal Repeater is the latest accessory to accompany Delphi's growing line of satellite radio products. The Signal Repeater helps you to enjoy XM programming even in locations without direct satellite reception. Just plug the repeater antenna into the antenna input of any XM satellite radio receiver and place it within **75 feet** of the transmitter, which rebroadcasts the XM signal picked up through your home antenna. Additional repeater antennas are available separately (SA10117-11P1), allowing multiple receivers to operate off a single transmitter.

**Note:** The Delphi XM Satellite Radio Signal Repeater may be used with any **home kit or audio system** compatible with SKYFi, SKYFi2, Rody, Rody2, or MyFi.

## About Delphi

Delphi is the premier provider of satellite radio products for the vehicle and home, selling more satellite digital audio receivers than any other company worldwide. A global leader in mobile electronics, vehicle components, and audio technology, Delphi created the first in-dash car radio in 1936 and continues its strong tradition of innovation in the audio industry. Now Delphi technology has helped make satellite radio a reality, and Delphi continues to expand its in-vehicle and consumer electronics technologies. With its exciting line of satellite radio products, Delphi offers a broad portfolio of products to answer a wide variety of information and entertainment needs—in the vehicle, home, office, or virtually anywhere. Visit [www.shopdelphi.com](http://www.shopdelphi.com) for more information.

## About XM

Established in October 1998, XM Satellite Radio launched its national broadcast service in November 2001. In just its first few years of commercial service, XM has grown faster than any other audio format in recent history. Broadcasting live daily from studios in Washington, D.C., New York City, and Nashville, Tenn., XM's channel lineup includes more than 150 digital channels of choice from coast to coast: 100 percent commercial-free music channels featuring hip hop to opera, classical to country, and bluegrass to blues; plus premier sports, talk, comedy, children's and entertainment programming; and more than 20 channels of the most advanced traffic and weather information for major metropolitan areas nationwide. And now, XM is the official satellite radio network of Major League Baseball, a new service that will provide real-time broadcast of all MLB games. For more information about XM, visit [www.xmradio.com](http://www.xmradio.com).





# Contents

<b>Section 1:</b> What's in the Box .....	1
<b>Section 2:</b> Setting Up the Delphi XM Satellite Radio Signal Repeater ..	2
Setting Up the Home Antenna .....	2
Setting Up the Transmitter .....	3
Setting Up the Repeater Antenna .....	4
<b>Section 3:</b> Operating Your Delphi XM Satellite Radio Signal Repeater ..	5
Placement and Mounting .....	5
Adjusting the Transmitter Antenna .....	7
Adjusting the Transmitter Output Power .....	8
Operating Near Other Wireless Devices .....	9
<b>Section 4:</b> References .....	11
Taking Care of Your Delphi XM Satellite Radio Signal Repeater System .....	11
Troubleshooting .....	12
Contacting Product Technical Support .....	14
Technical Information .....	14
Accessories .....	14
<b>Section 5:</b> Warranty .....	15

# Before You Begin

Please read all instructions thoroughly before setting up your Delphi XM Satellite Radio Signal Repeater.

# Section 1: What's in the Box

Your Delphi XM Satellite Radio Signal Repeater has the following components in the box:

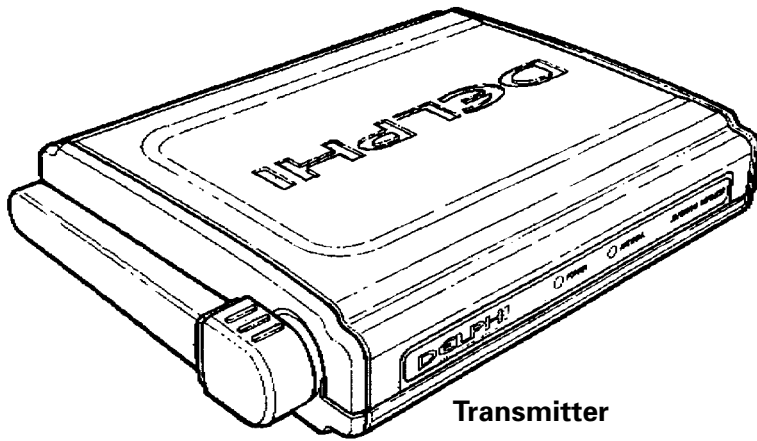

Transmitter

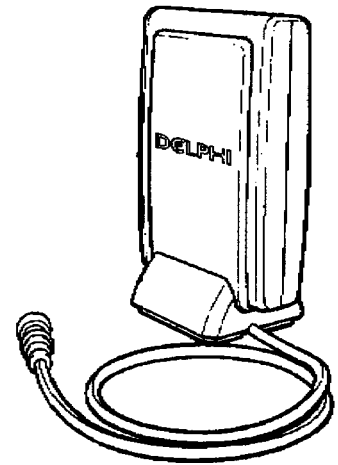

Repeater antenna

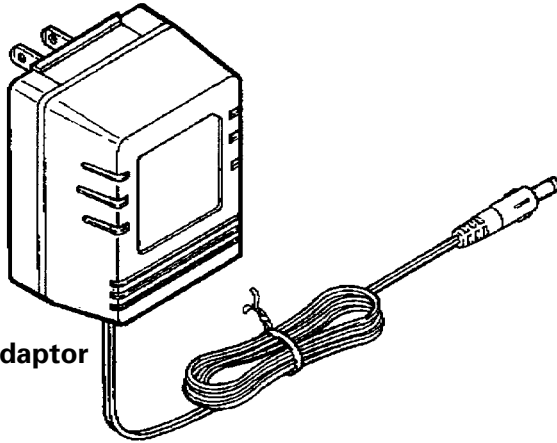

A/C power adaptor

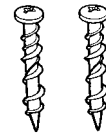

Mounting hardware

## Section 2: Setting Up the Delphi XM Satellite Radio Signal Repeater

To quickly begin using your Signal Repeater, follow the steps in this section. You may also have to refer to your satellite radio receiver user guide, available at [www.shopdelphi.com](http://www.shopdelphi.com).

### Setting Up the Home Antenna

Before setting up your Signal Repeater, set up your XM home antenna by following the instructions that came with your Delphi XM receiver home kit or audio system. Check to make sure you are receiving a signal with no error messages on the display. If you do not receive a signal or your satellite radio receiver's display reads "NO SIGNAL," try moving the satellite radio antenna to a new location. (A south-facing window is ideal.) If you are receiving an "ANTENNA" error message, do the following:

1. Turn your satellite radio receiver off, wait 10 seconds, then turn it back on.
2. Recheck the antenna connection.
3. Inspect the antenna cable to ensure it is not crimped, cut, or damaged.
4. If these actions do not have any effect, contact your retailer.

**Caution:** When testing the equipment, keep the transmitter and repeater antenna at least 3 feet apart. Placing them too close to each other could result in no operation due to an overly powerful signal.

## Setting Up the Transmitter

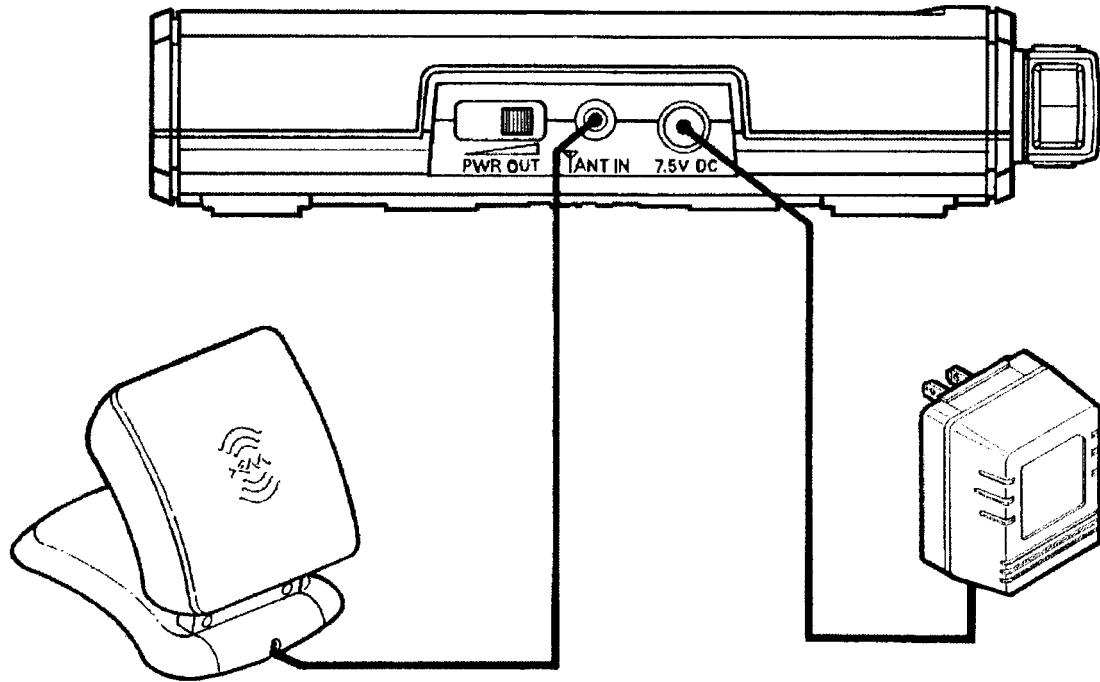

**Figure 1.** Connect your home kit's satellite radio antenna and the A/C power adaptor that came with your Delphi XM Satellite Radio Signal Repeater to the transmitter as shown. A blue light will turn on in the front of the unit when the A/C adaptor is plugged in, with a second blue light turning on when the antenna is connected.

**Caution:** Connect only appropriate input devices to the Delphi XM Satellite Radio Signal Repeater. Connecting an incorrect input device may damage the system and/or the external electronic device.

## Setting Up the Repeater Antenna

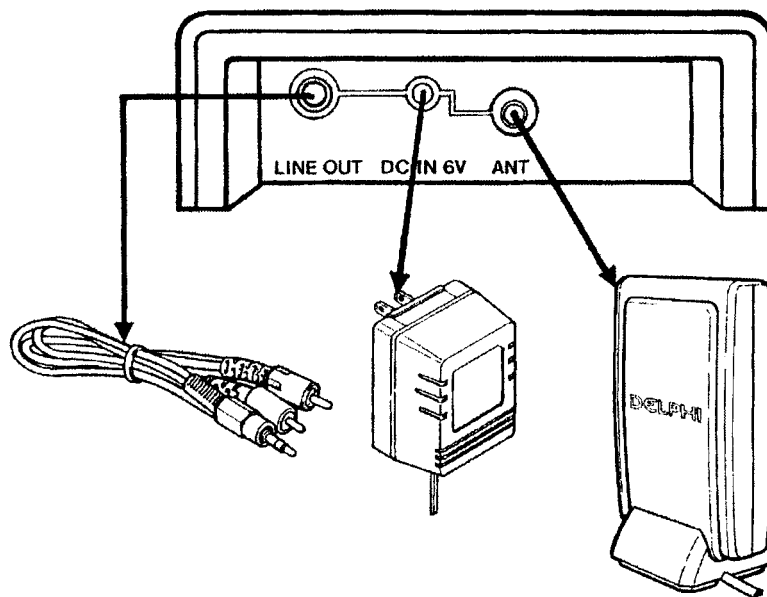

**Figure 2.** Connect the repeater antenna and the A/C adaptor that came with your home system to the back of your home stand as shown. If using a home kit, connect the ministereo (black connector) to the jack labeled “LINE OUT” on the back of the home stand. If your receiver does not have a built-in modulator or you choose not to use it, connect the red and white connectors to the input jacks on your home stereo equipment you want to use. See your satellite radio receiver user guide for more information. (Go to [www.shopdelphi.com](http://www.shopdelphi.com) to download a copy if you need a new one.)

**Caution:** Connect only appropriate input devices to your home stand. Connecting an incorrect input device may damage the system and/or the external electronic device. It is recommended that you use ONLY the A/C power adaptor that came with your home kit.

# Section 3: Operating Your Delphi XM Satellite Radio Signal Repeater

## Placement and Mounting

### Placement

Your Delphi XM Satellite Radio Signal Repeater transmitter should be placed in a location that allows for connection to a properly placed XM home antenna (i.e., near a south-facing window). See your satellite radio receiver user guide for more information on locating a suitable location for the antenna.

Your repeater antenna may be placed up to **75 feet** away from the transmitter. **The repeater antenna should be placed as high as possible for best reception. For optimal performance, place the repeater antenna in direct line of sight with the transmitter.**

**Note:** Any obstructions in the direct line of sight (such as furniture, walls, floors, or people) may result in degradation of signal.

Multiple repeater antennas may be operated off one transmitter device. Additional repeater antennas are sold separately. See page iii for example placements.

## Mounting

Your transmitter may rest flat on a horizontal surface, or it may be wall-mounted. To mount on a wall, insert two screws (provided) 2" apart in a horizontal line, leaving the screw heads approximately 1/4" from the wall. Slip the two holes located on the bottom of the transmitter over the screw heads and gently slide the unit down until it locks into place. (See figure 3.)

**Note:** The screws that came with your Signal Repeater may be fastened to wallboard or wood with an ordinary Phillips screwdriver; no pre-drilling is necessary. To fasten into concrete, hollow or grout filled block, brick, or plaster, pre-drill a 3/16" hole and fasten with an ordinary Phillips screwdriver.

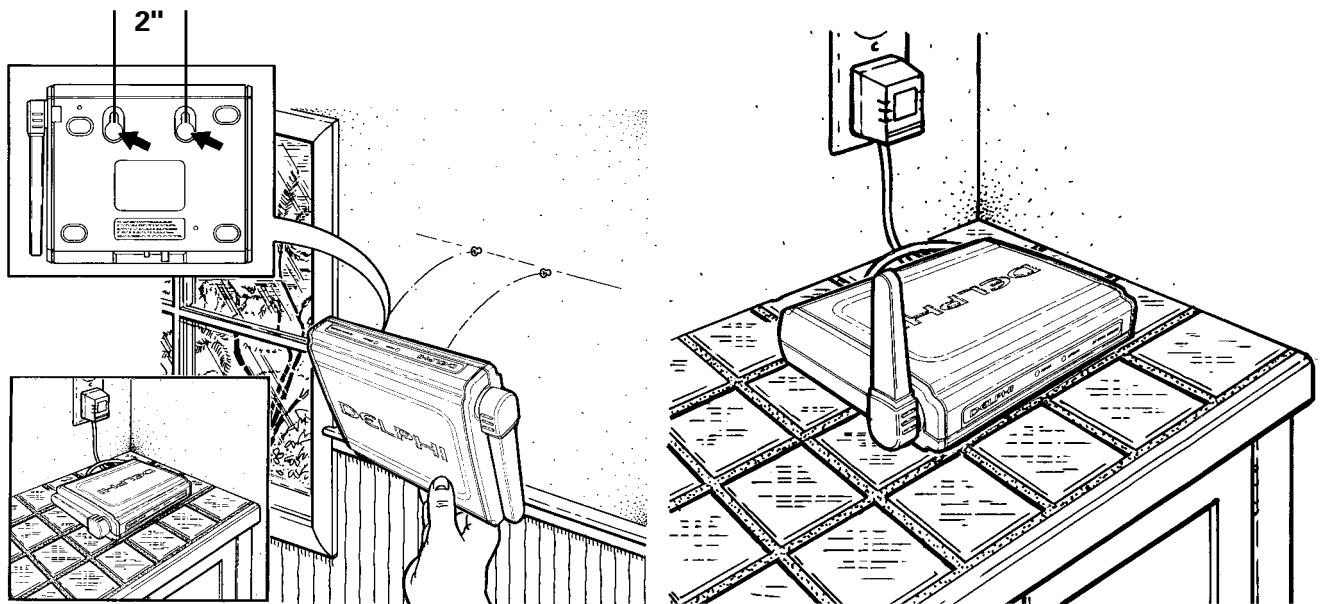

Figure 3.



Your repeater antenna is designed to stand vertically in the provided holder and should be placed on a horizontal surface near your satellite radio receiver.

## Adjusting the Transmitter Antenna

To ensure the strongest signal is being transmitted to your repeater antenna, adjust the transmitter's antenna as shown in figure 4. It is recommended you start with the antenna in a vertical position, then adjust it accordingly.

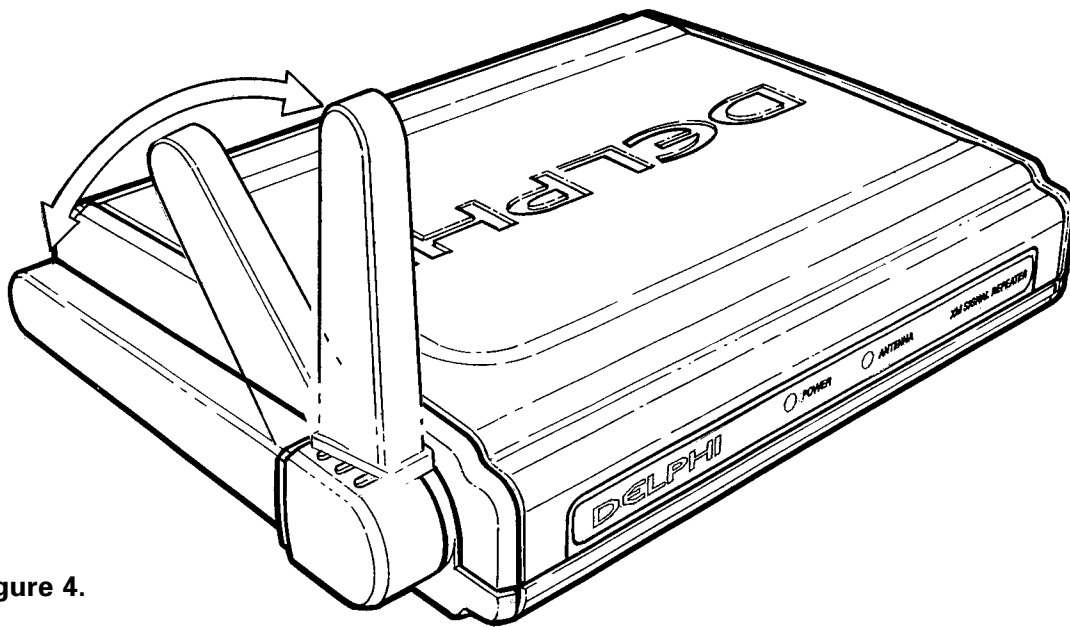

Figure 4.

## Adjusting the Transmitter Output Power

Your Delphi XM Satellite Radio Signal Repeater has four power output levels. These can be adjusted with the PWR OUT level switch located at the back of the transmitter. In situations where a lower output level may be desired (e.g., near other wireless devices or if someone else is using another transmitter), simply lower the output level by sliding the switch to the left. (See figure 5.)

**Note:** Operating at a lower output level decreases the range of your Delphi XM Satellite Radio Signal Repeater.

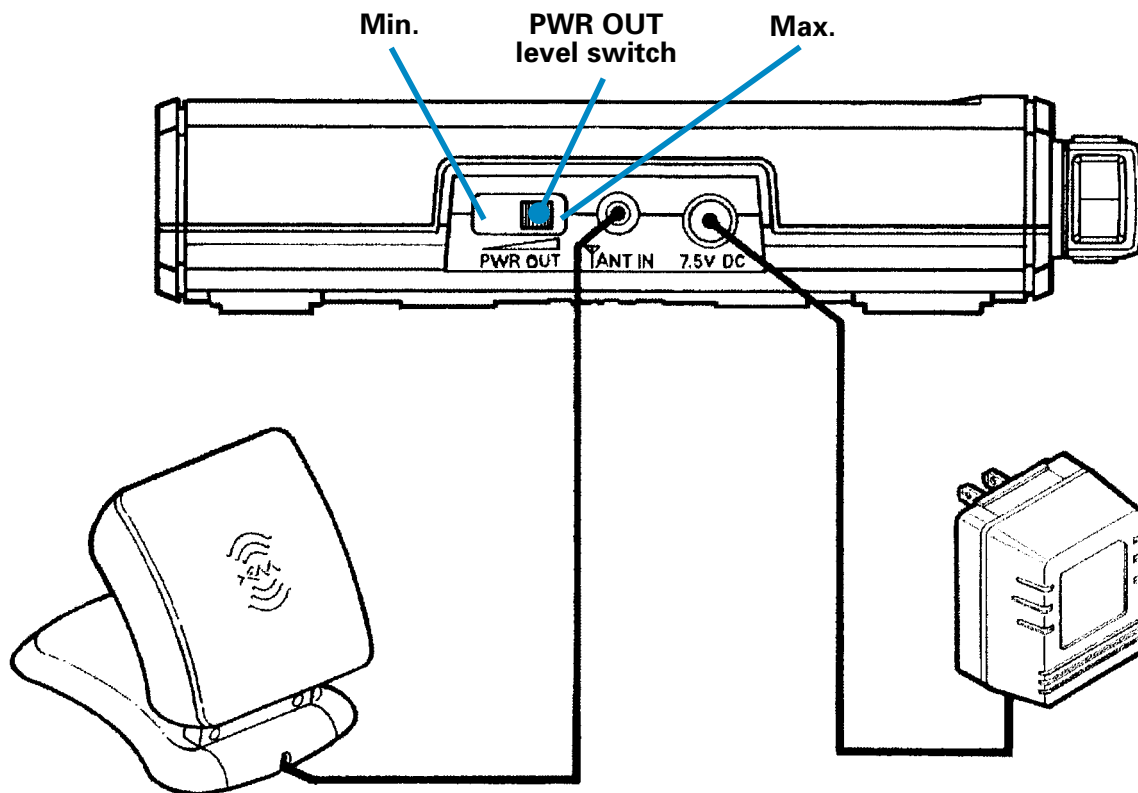

Figure 5.

## Operating Near Other Wireless Devices

Your satellite radio receiver may experience audio mutes when the repeater system is operated near other wireless devices such as phones, pagers, wireless computer peripherals, wireless LANS, etc. In addition, your repeater system may interfere with the operation of these wireless devices.

If it is determined other wireless devices are interfering with the transmitter, you should do one or more of the following:

- Move the interfering devices away from the transmitter.
- Disable other wireless devices, especially those in close proximity of the transmitter.
- Increase the repeater system output power as described on page 8 to enable the repeater to overcome the power from the interfering devices.
- Move the transmitter and/or the repeater antenna away from other wireless devices.
- Adjust the transmitter antenna position as described on page 7.

If it is determined the transmitter is interfering with other wireless devices, you should do one or more of the following:

- Decrease the repeater system output power as described on page 8.
- Move the transmitter and/or the repeater antenna away from other wireless devices.
- Adjust the transmitter antenna position as described on page 7.

## Section 4: References

### Taking Care of Your Delphi XM Satellite Radio Signal Repeater System

**Caution:**

- Use only a soft, dry cloth to clean the outside of your Delphi XM Satellite Radio Signal Repeater and any peripherals.
- Do not use any solvents, chemicals, or cleaning solutions containing alcohol, ammonia, or abrasives.
- Do not allow liquids to spill on the unit.
- Do not use sprays near your Delphi XM Satellite Radio Signal Repeater.
- It is best to keep your Delphi XM Satellite Radio Signal Repeater out of direct sunlight or other sources of extreme heat.
- Avoid placing your Delphi XM Satellite Radio Signal Repeater in a setting where air cannot circulate around it.

**Caution:** Refrain from consuming food or drinks near your Delphi XM Satellite Radio Signal Repeater. Spilling food or drinks on the transmitter or repeater antenna could cause damage to the product.

## Troubleshooting

Use the following troubleshooting section and the one from your satellite radio receiver user guide as needed. To obtain a copy of your satellite radio receiver user guide, go to [www.shopdelphi.com](http://www.shopdelphi.com).

Problem	Solution
The setup procedure does not work.	<ul style="list-style-type: none"> <li>• Ensure all components are plugged in correctly.</li> <li>• Check all connections and wires for noticeable damage.</li> <li>• Ensure you are in an open area with no obstructions such as large trees or buildings.</li> </ul>
You cannot receive XM channels.	<ul style="list-style-type: none"> <li>• Ensure your XM home antenna has a clear view of the sky. Try different locations.</li> </ul>
There is no audio.	<ul style="list-style-type: none"> <li>• Check to see if another transmitter or wireless device is in the area. Move your transmitter, or try a higher power level.</li> </ul>
Cordless phone does not work.	<ul style="list-style-type: none"> <li>• Move transmitter to a new location, set it to a lower power level, or turn off while phone is in use.</li> </ul>

<b>Problem</b>	<b>Solution</b>
You cannot receive XM signal.	<ul style="list-style-type: none"><li data-bbox="743 768 1354 940">• Ensure line of sight between transmitter and repeater antenna is not blocked. Move antenna to new location.</li><li data-bbox="743 974 1419 1108">• Make sure mobile phones or other similar devices are not being used in close proximity to Signal Repeater.</li></ul>

## Contacting Product Technical Support

For additional information or assistance with your Delphi XM Satellite Radio Signal Repeater, contact Delphi Technical Support at 1.877.GO DELPHI (1.877.463.3574) 8 a.m.—8 p.m. Eastern Time, Monday—Friday. *Technical Support is also available at [www.shopdelphi.com](http://www.shopdelphi.com).* To obtain a copy of any Delphi satellite receiver user guide, visit [www.shopdelphi.com](http://www.shopdelphi.com).

## Technical Information

### Dimensions:

Transmitter: 6.25 in. W x 4.7 in. D x 1.3 in. H  
(159 mm W x 119 mm D x 33 mm H)  
Repeater antenna: 2.75 in. W x 1.75 in. D x 4 in. H  
(70 mm W x 44.5 mm D x 102 mm H)

### Weight:

Transmitter: 7.23 oz. (205 g)  
Repeater antenna: 3.88 oz. (110 g)

### Inputs and Outputs:

Transmitter: Antenna in/out: RF SMB (jack) connector output,  
5.5 V DC, 100 mA maximum inputs  
Repeater antenna: Antenna in: RF SMB (plug) connector  
DC in: 2.5 mm power jack, 7.5 V DC,  
700 mA maximum inputs  
Power: 7.5 V, 700 mA maximum current, positive polarity

## Accessories

For a list of other accessories, visit [www.shopdelphi.com](http://www.shopdelphi.com).



## Section 5: Warranty

### Delphi Limited Consumer Warranty

Delphi Product and Service Solutions (“Delphi”) warrants all XM Satellite Radio Products sold by Delphi (each “Product”) to be free of defects in material and workmanship, subject to the following conditions:

The duration of Delphi’s warranty with respect to the Delphi XM Satellite Radio Signal Repeater Product is limited to one (1) year from the date of sale to the original consumer purchaser.

**No other express warranties are made with respect to any Product. All implied warranties, including warranties of merchantability and fitness for a particular purpose are limited to the warranty period set forth above. This warranty is not transferable and applies only to the original consumer purchaser of the Product.**

Delphi will, as its sole obligation under this warranty, replace or repair, at its option, any Product that does not conform to this warranty. Products may be repaired or replaced with new or with refurbished items. This limited warranty does not cover defects in appearance, cosmetic or decorative items, including any non-operative parts. Under no circumstances will Delphi be liable for any incidental or consequential damages under this warranty or any implied warranties. These remedies are the customer’s exclusive remedies for breach of warranty. This limited warranty only extends to customers who purchase the Products in the United States.

Delphi will not be responsible for damage resulting from any (i) deviation from Delphi’s operating instructions as printed in Delphi’s catalog or on any packaging, labels, or other literature provided with a Product, (ii) installation of a Product in a manner which is inconsistent with Delphi’s written instructions, (iii) alteration or modification of a Product, (iv) misuse, (v) neglect, (vi) abuse, (vii) accident, (viii) normal wear and tear, (ix) commercial use, (x) improper storage, (xi) environmental conditions, including excessive temperature or humidity, (xii) service by anyone other than a Delphi authorized repair facility, (xiii) other improper application, installation, or operation of the Product, or (xiv) defects or malfunctions of which Delphi is not advised within ten (10) days of the expiration of the limited warranty period.

## **How You (the Customer) Can Get Service**

To obtain warranty service during the first thirty (30) days after the date of purchase, you must return the defective Product with the original receipt to the original place of purchase. To obtain warranty service during the first thirty (30) days for Products purchased from [www.shopdelphi.com](http://www.shopdelphi.com) and for all Products for the remainder of the limited warranty period, you must contact Delphi by phone at 1.877.GO DELPHI (1.877.463.3574) or by fax at 1.866.790.3675. When contacting Delphi by fax, please include a letter detailing your complaint and a daytime telephone number where you can be reached. If further clarification or additional information is required from Delphi, you may call Delphi at 1.877.GO DELPHI (1.877.463.3574).

**If warranty service is needed at any time during the warranty period, the purchaser will be required to furnish a sales receipt/proof of purchase indicating the date of purchase, amount paid, and place of purchase. Customers who fail to provide such proof of purchase will be charged for the repair/replacement of any Product.**

## **How State Law Relates to the Warranty**

Some states do not allow limitations on how long implied warranties last, or the exclusion or the limitation of incidental or consequential damages. So the above limitations or exclusions may not apply to you. This warranty gives you specific legal rights. You may also have other rights that may vary from state to state.

**NO PERSON IS AUTHORIZED BY DELPHI TO MODIFY OR ADD TO THIS LIMITED WARRANTY.**



# DELPHI

Delphi Corporation  
1441 West Long Lake Road • Troy, Michigan 48098-5090 U.S.A.  
Customer Service/Technical Support: [1] 877.GO DELPHI

**[www.delphi.com](http://www.delphi.com)**

**[www.shopdelphi.com](http://www.shopdelphi.com)**

XM, SKYFi, and Roady are trademarks of XM Satellite Radio Inc.  
MyFi is a trademark of Delphi Corporation.

© 2005 Delphi Corporation. All rights reserved.  
DPSS-05-E-006