

Re: Certification for Delphi Delco SR Radar
PN: 09369080
FCC ID: L2C0015TR
CANADA: to be provided by IC

USER'S MANUAL INFORMATION

(PRELIMINARY)

The Vehicle User's Manual is in preparation. The following material will be contained in the manual:

FCC ID: L2C0015TR

CANADA: to be provided by IC

This device complies with Part 15 of the FCC Rules and with RSS-210 of Industry Canada. Operation is subject to the following two conditions:

- (1) This device may not cause harmful interference, and
- (2) This device must accept any interference received, including interference that may cause undesired operation.

WARNING: Changes or modifications not expressly approved by the party responsible for compliance could void the user's authority to operate the equipment.

**XK SERIES
DRIVERS
HANDBOOK
SUPPLEMENT**

JJM 13 02 14/001

2 Adaptive Cruise Control

Adaptive Cruise Control (ACC)

For your added comfort and convenience this vehicle is fitted with adaptive cruise control. This system maintains a gap from the vehicle ahead or a set road speed if there is no slower vehicle ahead. The system is intended to provide enhanced operation of the vehicle when following other vehicles which are in the same lane and travelling in the same direction.

Note: This Supplement supercedes the cruise control operation shown in the Driver's Handbook on pages 3-19 and 3-20.



WARNING:

Adaptive cruise control is not a collision warning or avoidance system. It will not detect:

- stationary or slow moving (below 10km/h) vehicles.
- pedestrians or objects in the roadway.
- oncoming vehicles in the same lane

Only use adaptive cruise control when conditions are favourable, that is, straight, dry, open roads with light traffic.

It is the drivers responsibility to stay alert, drive safely and be in control of the vehicle at all times.

Keep the front of the vehicle free from dirt, metal badges or objects which may prevent the sensor from operating.

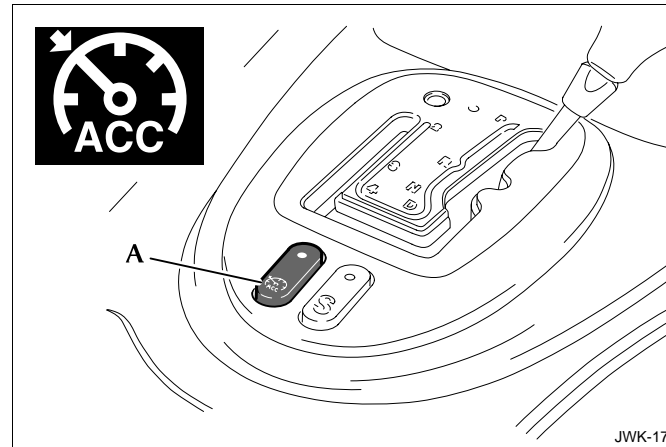

The system is operated by an ON/OFF master switch (A) mounted in the gear selector surround and six switches mounted on the steering wheel. Brake operation also influences the cruise control system.

Adaptive Cruise Control 3

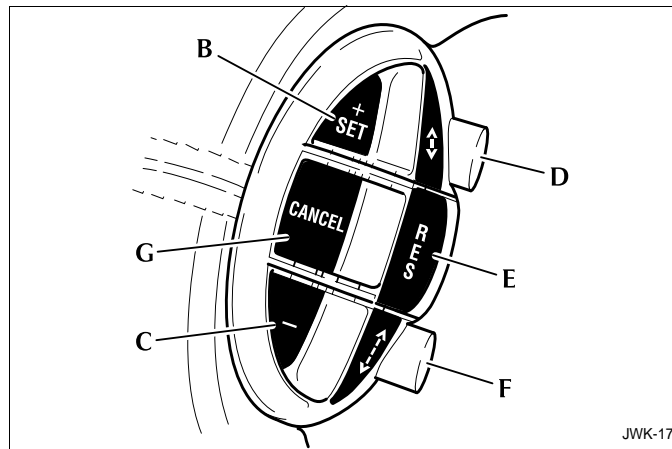

The steering wheel switches operate as follows:

- (B) 'SET +': Set speed or accelerate
- (C) '-': Decelerate
- (D) <=> Gap decrease
- (E) 'RESUME': Resume set speed
- (F) <- -> Gap increase
- (G) 'CANCEL': Cancels without erasing memorised speed

Setting a speed

Push the ON/OFF switch (A) and allow it to come to the raised position. A red warning light on the switch will come on indicating that the system is available for use, unless there is a fault with the system.

Accelerate as normal until the required speed is reached.

Press the 'SET +' button (B) briefly and the vehicle speed will then be stored in the memory and the system engaged. The set speed will be displayed on the message centre.

SETSPEED
130 km/h

Entering the follow mode



WARNING:

When in follow mode the vehicle will not decelerate automatically to a stop, nor will the vehicle always decelerate quickly enough to avoid a collision without driver intervention.

Once a set speed has been selected, the driver can release the accelerator and the set road speed will be maintained.

When a vehicle ahead enters the same lane or a slower vehicle is ahead in the same lane, the vehicle speed will be adjusted automatically until the time gap to the vehicle ahead corresponds to the gap allowed by the system. The vehicle is now in 'follow mode'.

The tell tale in the instrument cluster will be illuminated

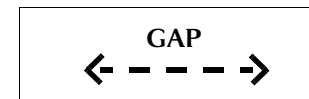

and the message centre will display the gap for four seconds.

4 Adaptive Cruise Control

The vehicle will then maintain the constant time gap to the vehicle ahead until:

- the vehicle ahead accelerates to a speed above the set speed.
- the vehicle ahead moves out of lane or out of view.
- the vehicle ahead slows so that 'low speed automatic switch off' occurs.
- a new gap distance is set.

If necessary, the vehicle brakes will be automatically applied to slow the vehicle to maintain the gap to the vehicle in front. The maximum braking rate which is applied by the ACC system is limited and can be overridden by the driver intervening and applying the brakes, if required.

Note: Driver braking will cancel the adaptive cruise control function.

If the ACC uses its maximum braking level then an audible warning will sound while the ACC continues to brake. This is accompanied by a red warning light and 'DRIVER INTERVENE' will be displayed on the message centre. The driver should take IMMEDIATE action.

When in follow mode the vehicle will automatically return to the set speed when the road ahead is clear or the vehicle in front is beyond the set gap or changes lane.

Low speed automatic switch off

If the speed of the vehicle decreases below 24 km/h, the ACC system will be automatically switched OFF and the tell tale will go out. If the brakes were being applied by the ACC system, they will be slowly released. This will be accompanied by an audible warning, a red warning light and 'DRIVER INTERVENE' will be displayed on the message centre. The driver must take control.

Overriding the set speed /follow mode

The set speed and gap can be overridden by pressing the accelerator pedal when cruising at constant speed or follow mode. If the vehicle is in follow mode, the tell tale indicator will go out when the ACC is overridden by the driver using the accelerator and 'CRUISE OVERRIDE' will be displayed on the message centre. When the accelerator is released the ACC function will operate again and vehicle speed will decrease to the set speed, or a lower speed if follow mode is active.



WARNING:

Whenever the driver is overriding the ACC, the ACC automatic braking will not be available to maintain separation from any vehicle ahead.

Adaptive Cruise Control 5

Changing the set speed

There are three ways to change the set speed:

1. Accelerate or brake to the required speed and press the 'SET +' button (B).
2. Increase or decrease the speed by pressing and holding either the 'SET +' (B) or '-' (G) button until the required set speed is shown on the message centre. The vehicle speed will gradually change to the selected speed.
3. Increase or decrease the speed in steps of 2 km/h (1 mph) by briefly pressing the 'SET +' (B) or '-' (G) button.

The ACC may apply the brakes to slow down the vehicle to the new set speed. The new set speed will be displayed on the message centre for four seconds after it has been changed.

Changing the gap

The distance (time gap) from the vehicle ahead can be decreased or increased by pressing the buttons (D) or (F) on the steering wheel. The selected gap will be displayed on the message centre when either button is pressed as shown below:

| Gap selected | Display |
|-------------------|---------|
| Maximum (default) | <-----> |
| Intermediate | <---> |
| Minimum | <-> |

After the ignition is switched ON the maximum gap will be automatically selected ready for ACC operation.

Note: It is the driver's responsibility to select a gap appropriate to the driving conditions.

ACC automatic switch off

Adaptive cruise control will disengage, but not clear the memory when:

- the CANCEL button (G) is pressed.
- the brake pedal is pressed.
- the vehicle speed falls below 24 km/h.
- Neutral, Park or Reverse gear positions are selected.
- traction control is activated.

Adaptive cruise control will disengage, and clear the memory when:

- the ON/OFF switch (A) is set to off.
- the ignition switch is set to position '0'.
- the handbrake is applied.
- maximum vehicle speed is reached.
- if a fault occurs in the ACC system.

Resuming the set speed/follow mode

By pressing the resume button (E) after ACC has been cancelled, for example, after braking, the ACC will become active again provided that the set speed memory has not been erased. The set speed will be displayed for four seconds and the original set speed will be resumed, unless a vehicle ahead causes the follow mode to become active.

Caution: 'RESUME' should only be used if the driver is aware of the set speed and intends to return to it.

6 Adaptive Cruise Control

ACC failure

If a fault occurs during operation of the system in cruise or follow modes, the ACC system will switch OFF and will not be able to be used until the fault is cleared. A red warning light will be displayed accompanied by the message 'DRIVER INTERVENE' on the message centre.

If failure of the ACC or any related system occurs at any other time an amber warning light will be displayed accompanied by the message 'CRUISE NOT AVAILABLE'. It will not be possible to activate the ACC system in any mode.

Notes on using cruise control

1. Cruise control operates when the gear selector lever is in position '2', '3' '4' or 'D'.
2. When engaged, the accelerator pedal rests in the raised position.
3. When braking is applied by the ACC the brake pedal will move down and up as braking is applied or removed. The vehicle brake lights will be switched on while braking applied.

Driving with ACC active

The system acts by regulating the speed of the vehicle through the accelerator and brakes only. Gear changes may occur in response to deceleration or acceleration whilst under ACC influence.

ACC is not a collision avoidance system, however, during some situations the system may provide the driver with an indication that intervention is required.

If the ACC detects:

- that it is using maximum braking level
 - that the vehicle speed has decreased below the minimum for ACC operation
 - a failure has occurred whilst the system is active
- then an audible alarm will sound, accompanied by a red warning light and the message 'DRIVER INTERVENE'

Adaptive Cruise Control 7

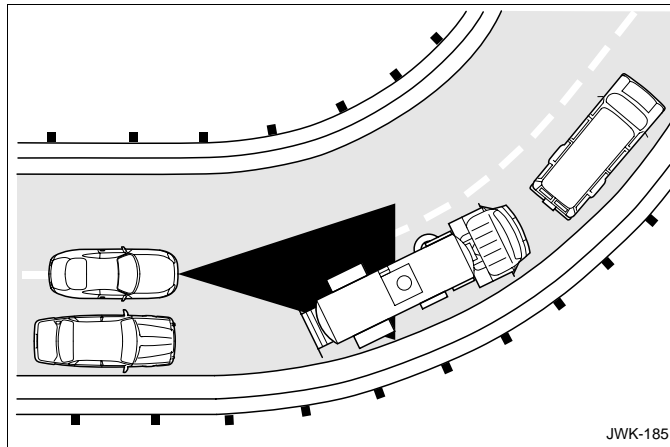

There may be problems with the detection of vehicles in front when going into and coming out of a bend.

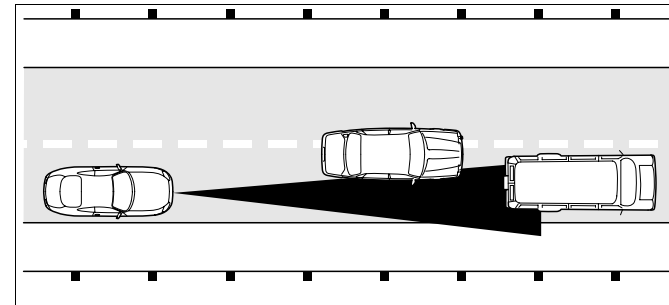

Detection problems can also occur:

- when driving on a different line to the vehicle in front (illustration above) or

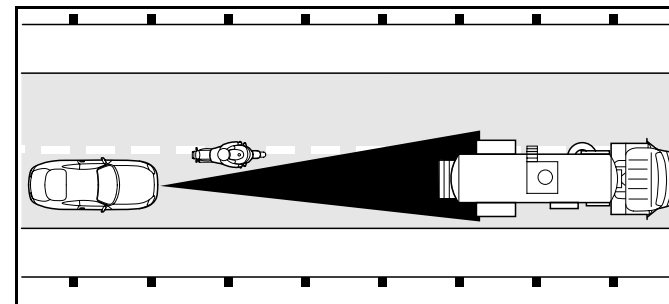

- with vehicles which edge into your lane which can only be detected once they have moved fully into your lane (lower illustration).

8 Adaptive Cruise Control
