



# Invisible Fence<sup>®</sup>

BRAND

***Installation Manual***  
***ICT 801, ICT 802, ICT 810 Transmitters***  
***R21 v4.0 Computer Collar<sup>®</sup> Receiver***

---

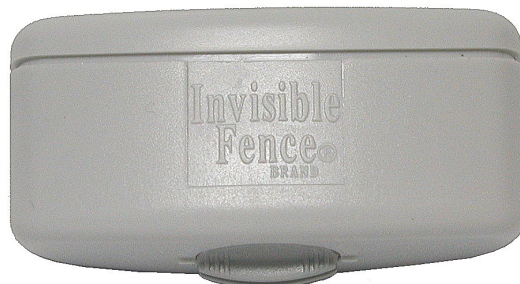
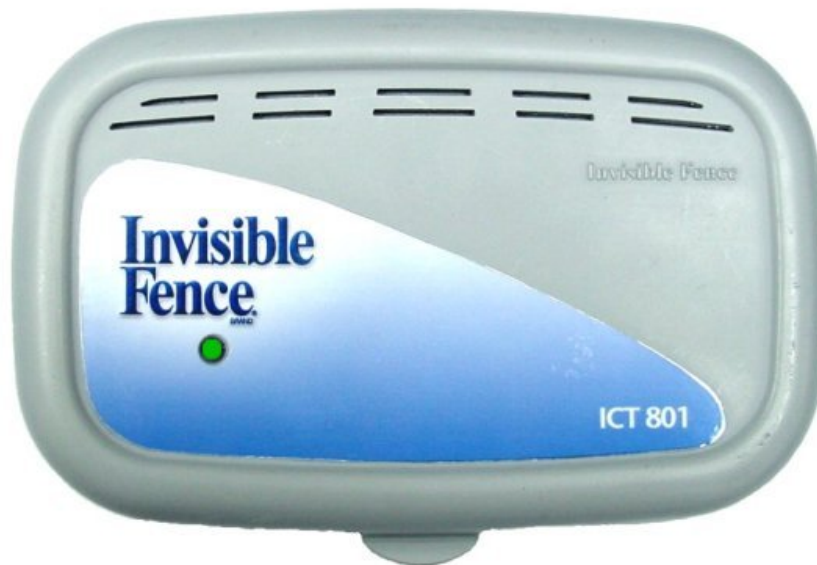

## Foreword

This document contains important information regarding the installation and operation of the ICT 801, ICT 802, and ICT 810 Transmitters, and the R21 v4.0 Titanium Computer Collar®. Prior installation of signal field wire is assumed. Review all instructions before installation and use.

## System Information

The ICT 801, ICT 802, and ICT 810 Transmitters are used as part of an Invisible Fence® Brand pet containment system. These transmitters must always be installed in a dry, protected area to insure they will not be exposed to the elements.

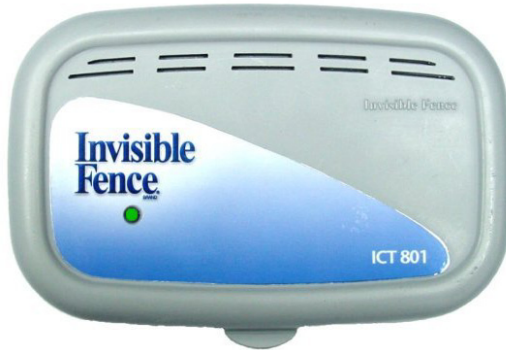

The transmitters are connected to an external signal field wire and send a coded, digital signal along the entire length of wire. The following wire specification should be followed:

	ICT 801 / ICT 802 Up to 3,000 ft.	ICT 810 Up to 5,000 ft.
Feet of twisted pair	150 feet	200 feet
Wire size	14 AWG	12 AWG *
Jacket	PE .045"	PE .045"

\*12 AWG is recommended, however, it may require a pigtail to 14 AWG for insertion into the LP-4100 or LP-4200 connectors.

The ICT 801 and ICT 802 are programmable to transmit a digital signal either at 7KHz or at 10KHz, whereas the ICT 810 transmits only a 7KHz digital signal. **The ICT 801, ICT 802, and ICT 810 Transmitters are only compatible with the R21 v4.0 Titanium Computer Collar®.** All ICT 801, ICT 802, and ICT 810 Transmitters have removable circuit boards that can be replaced if damaged.

## Planning the Installation

Install the transmitter in a dry indoor location, near a grounded 110VAC electric outlet that offers easy access to the outdoors. A garage or basement is usually the best location. **If you are not sure the intended outlet is grounded, use a 3-wire circuit analyzer or contact an electrician.** To fasten the transmitter base to the wall, you need four ¾ inch long (19mm), #8, or #10 pan-head sheet metal screws.



**Caution: Never install a system or equipment, or service any equipment, during a thunderstorm or electrical storm, or when thunder or lightning is in your area.**

## Connecting the Signal Field Wire



All Invisible Fence® Brand Pet Containment Systems must be grounded per the NATIONAL ELECTRICAL CODE (NEC) to be protected against lightning. ICT 801, ICT 802, and ICT 810 Transmitters must be installed using the LP-4100 (ICT 801 and ICT 810) or LP-4200 (ICT 802) Lightning Protection devices in accordance with the NEC and applicable local building codes.

1. Strip approximately ¼ inch (6.3mm) of insulation from each end of the signal field wires (in-ground containment loop). Using your finger, depress the tab of one red connector (marked LOOP) on the Lightning Protector. Insert one stripped end of the signal field wire into the red connector hole. Release the tab. Repeat for the remaining signal field wire. **Note: Insert only one wire per hole.**

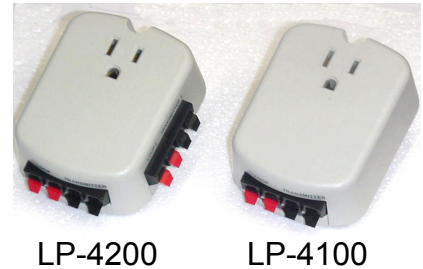

2. Next, connect the ICT 801, ICT 802, or ICT 810 transmitter to the LP-4100 or LP-4200 with a short length of twisted pair wire. Strip approximately ¼ inch (6.3mm) of insulation from each end of the twisted pair wires. Insert one of the twisted pair transmitter wires into a black connector hole (marked TRANSMITTER) of the LP-4100 or LP-4200 in the same manner as the signal field wires connected in step #1. Repeat for the remaining twisted pair wire. **(Remember — insert only one wire per hole)**

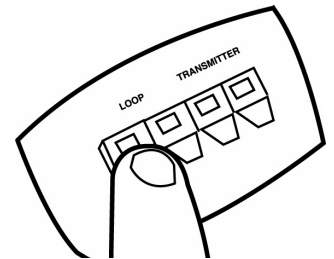

3. Connect the other end (stripped the same way as in step #2) of the twisted pair wires to the transmitter via the signal field connectors. Use your thumb to push back on the white tabs located on top of the signal field wire connectors. While pushing back the tabs, put the end of each wire into each opening of the connectors. Hold the wires steady, and release the tabs.

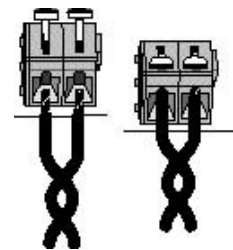

4. Before plugging in the LP-4100 or LP-4200, make sure the electric outlet is properly grounded. Remove the plastic cover that protects the plug on the LP-4100 or LP-4200 and plug it into a grounded 3-prong household outlet (110VAC) within five feet (5') of where you wish to install the transmitter. When possible, use the center screw that holds the outlet cover plate in place. If this screw is missing or not long enough, use the longer screw provided with the Lightning Protector. NOTE: This screw is for mechanical attachment only and does NOT provide electrical ground!

*Instructions are continued on the next page...*

5. Plug the transmitter power AC adapter into the 3-prong socket in the LP-4100 or LP-4200.

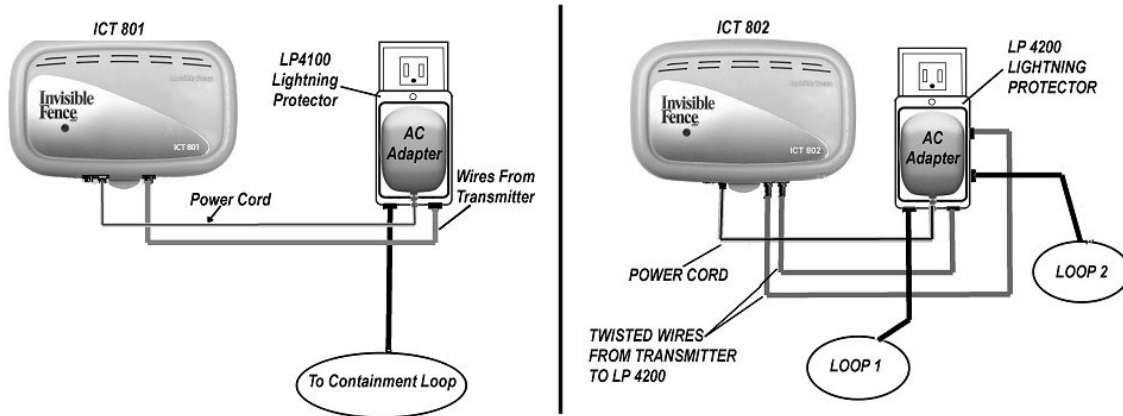

6. Install the transmitter base to the wall using four  $\frac{3}{4}$  inch long (19mm), #8, or #10 pan-head sheet metal screws. Insert the screws through the four mounting holes (shown below) in the base of the transmitter case.

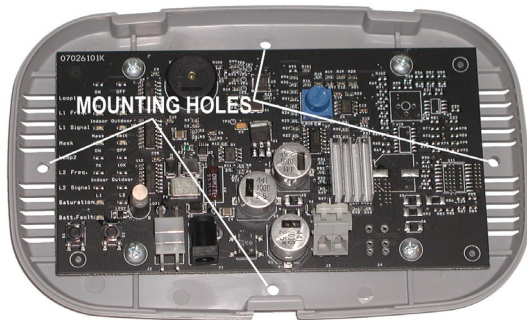

**NOTE:** The Invisible Fence® Brand system and the LP-4100/LP-4200 will function properly in a GFCI outlet. In rare cases, lightning strikes or overload fault conditions may cause the GFCI to trip. You must instruct the homeowner to reset the tripped CFCEI outlet in order for the Invisible Fence® Brand system to function properly.



**IMPORTANT NOTE:** Always use a grounded 3-prong 110VAC outlet with the LP-4100/LP-4200 in order to ensure maximum lightning surge protection. Please note that removing the center ground pin from an LP-4100/LP-4200 will void the warranty. This product must always be located in a dry, protected area where it will not be exposed to the elements. For installations with ungrounded, 2-prong 110VAC outlets, refer to Technical Bulletin #0204 – Procedure for Grounding LP-4000 Series Module.

## ICT 801 Transmitter

The ICT 801 is a single loop programmable transmitter designed for installations with up to 3,000 feet of signal field wire and up to 150 feet of twisted pair wire. The ICT 801 has one signal field adjustment to increase or decrease the width of the signal field. See page 11 for instructions for setting the signal field width.

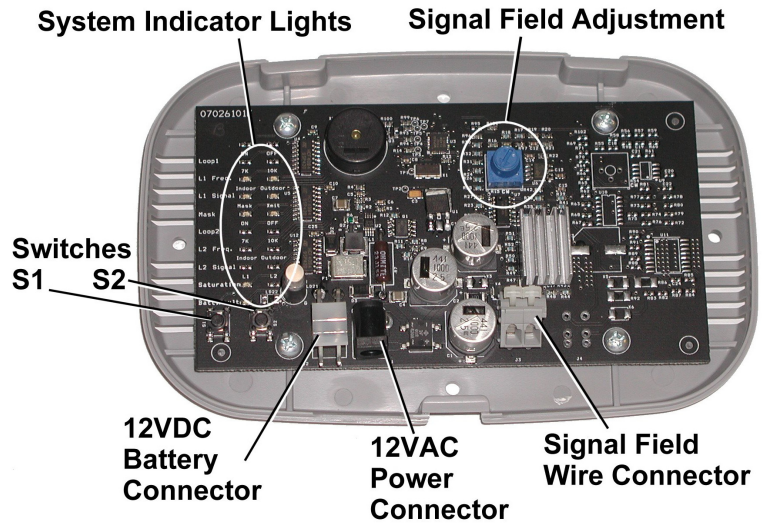

### User Settings and Functions for ICT 801 Transmitter:



System Indicator Lights

**Loop 1:** Loop 1 is always functioning on the ICT 801. (No indicator light on the circuit board.)

**L1 Freq.:** Select either 7K or 10K signal for Loop 1. The default setting is 7K.

**L1 Signal:** Select either Indoor or Outdoor mode for Loop 1. The default setting is Outdoor.

**Mask:** Select either Mask or Xmit to transmit a mask or boundary signal for Loop 1. The default setting is Xmit.

**Saturation:** Indicates Loop 1 transmitter output saturation. Loop saturation exists when the signal has reached maximum output level, which is caused by excessive loop size, excessive resistance, or poor connections.

**Batt. Fault:** Indicates when 12VDC backup battery is not installed or not working properly.

## ICT 802 Transmitter

The ICT 802 is a dual loop programmable transmitter. Each loop on the ICT 802 can have up to 3,000 feet of loop wire and up to 150 feet of twisted pair. Signal width for each loop can be adjusted by using the signal field adjustments for Loop 1 and Loop 2.

See page 11 for instructions for setting the signal field width.

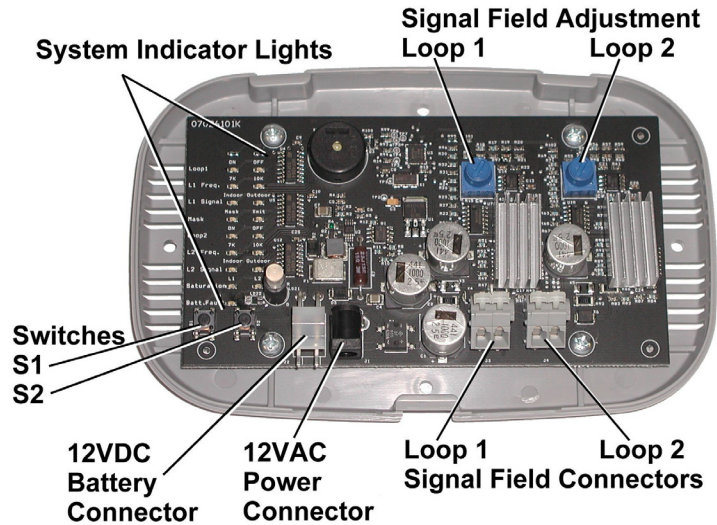

## User Settings and Functions for ICT 802 Transmitter:



System Indicator Lights

**Loop 1:** Used to turn Loop 1 LED circuitry ON or OFF. If OFF is selected, all LEDs for Loop 1 will not light.

**L1 Freq.:** Select either 7K or 10K signal for Loop 1. The default setting is 7K.

**L1 Signal:** Select either Indoor or Outdoor mode for Loop 1. The default setting is Outdoor.

**Mask:** Select either Mask or Xmit to transmit a mask or boundary signal for Loop 1. The default setting is Xmit.

**Loop 2:** Used to turn Loop 2 LED circuitry ON or OFF. If OFF is selected, all LEDs for Loop 2 will not light.

**L2 Freq.:** Select either 7K or 10K signal for Loop 2 if the loop is ON.

**L2 Signal:** Select either Indoor or Outdoor mode for Loop 2 if the loop is ON.

**Saturation:** Indicates Loop 1 and/or Loop 2 transmitter output saturation. Loop saturation exists when the signal has reached maximum output level, which is caused by excessive loop size, excessive resistance, or poor connections.

**Batt. Fault:** Indicates when 12VDC backup battery is not installed or not working properly.



**Important:** When using Loop 1 of the ICT 802 transmitter as a Mask, remember to adjust the Mask signal appropriately. Make sure the Mask signal is not radiating further than the actual signal bleed it is masking. To measure the Mask field, turn off the containment loop, change the Mask loop back to transmit mode (Xmit), and measure the signal field with a R21 v4.0 receiver where the Mask is placed. Change the loop back to Mask mode when finished.



## ICT 810 Transmitter

The ICT 810 is a single loop programmable transmitter designed for installations with up to 5,000 feet of signal field wire and up to 200 feet of twisted pair wire. The ICT 810 has one signal field adjustment to increase or decrease the width of the signal field. See page 11 for instructions for setting the signal field width.

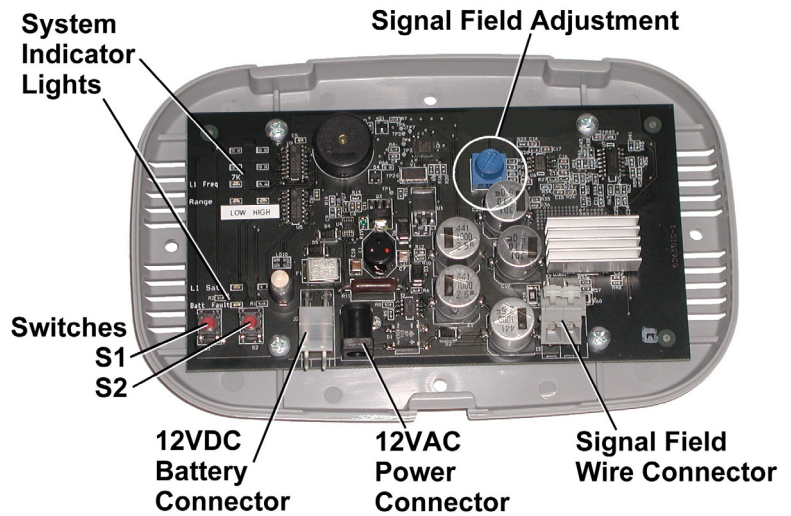

## User Settings and Functions for ICT 810 Transmitter:

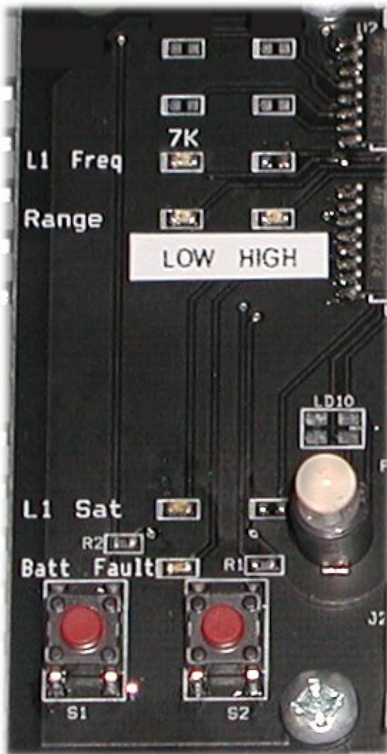

System Indicator Lights

**L1 Freq.:** ICT 810 is always set to **7K**.

**Range:** ICT 810 range can be set to **LOW** or **HIGH**. This setting adjusts the sensitivity of the signal field adjustment knob. Using the **LOW** range setting allows for smaller signal field setting while the **HIGH** range setting will create a larger signal field.

**L1 Sat:** Indicates Loop 1 transmitter output saturation. Loop saturation exists when the signal has reached maximum output level, which is caused by excessive loop size, excessive resistance, or poor connections.

**Batt. Fault:** Indicates when 12VDC backup battery is not installed or not working properly.

## Typical ICT 801 and ICT 810 Installation

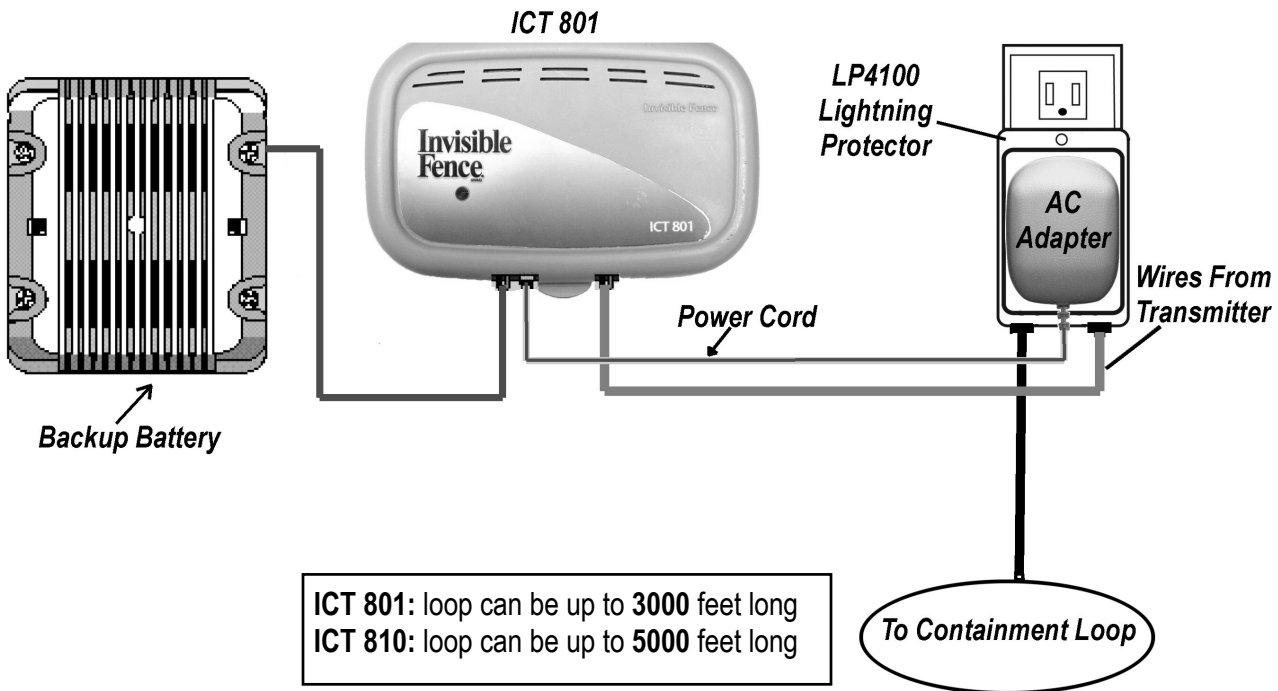

## Typical ICT 802 Installation

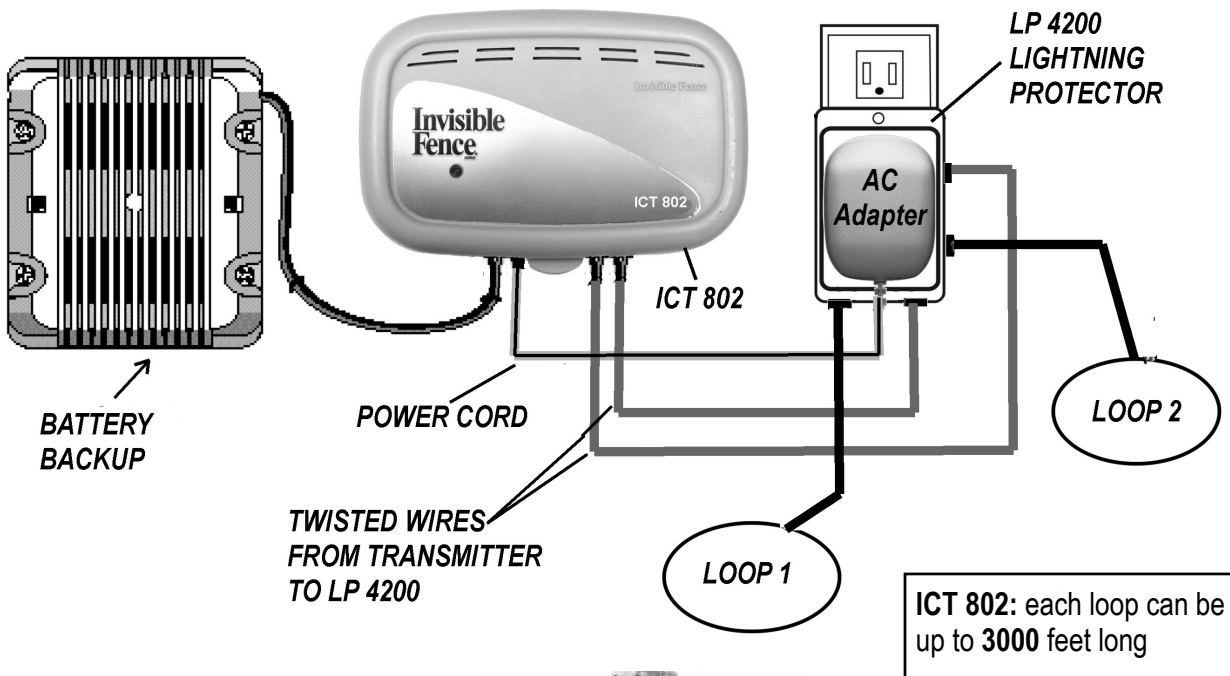



## Programming the ICT 801, ICT 802, and ICT 810 Transmitters

On first time power up, the LED status indicator lights will display the following default settings.

Indicator	Default Setting
Loop 1	ON
L1 Freq.	7K
L1 Signal	Outdoor
Mask	Xmit
Loop 2	Off (for 802 model only)
Range	LOW (for 810 model only)

Once the transmitter has been programmed, the settings will remain in the system memory. To program the transmitter:

1. Press and hold the S1 button for approximately 4 seconds until
  - a. For ICT 801: The L1 Freq. LED begins to blink.
  - b. For ICT 802: The Loop 1 LED begins to blink.
  - c. For ICT 810: The Range LED begins to blink.
2. Release the S1 button.
3. Momentarily press and release the S2 button to toggle between each setting option.
4. Press and release the S1 button to move to the next setting.
5. Continue until all choices are selected.
6. The cursor LED will stop blinking approximately ten seconds after the buttons are released, and the transmitter will automatically exit the programming mode.



**IMPORTANT:** If the transmitter is disconnected from the power source while the status indicator lights are still blinking, the settings will not be saved to the system memory.

**LED Status Indicator Light:** This is the only visible light from outside of the enclosure when the cover is closed.

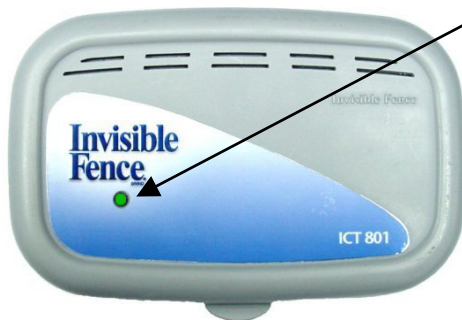

### LED Status Indicator Light

**Audible Alarm:** There is an audible alarm for certain alert conditions (See table on page 10). Press and release either the S1 or the S2 button on the circuit board to silence the alarm. The alarm will re-activate on power-up, or when exiting set-up mode (if a failure condition still exists).

## **ICT 800 Series – Status Light and Audible Alarm Troubleshooting**

<b>Status</b>	<b>LED Color</b>	<b>Indicator</b>	<b>Audible Alert</b>
System OK	<b>GREEN</b>	<ul style="list-style-type: none"> <li>• Slow green flash</li> <li>• 1 second on, 4 seconds off</li> </ul>	<ul style="list-style-type: none"> <li>• None</li> </ul>
AC Failure (Only if optional Backup Battery is installed)	<b>RED</b>	<ul style="list-style-type: none"> <li>• Slow red flash</li> <li>• 1 second on, 4 seconds off</li> </ul>	<ul style="list-style-type: none"> <li>• Chirp every 5 seconds (Can be silenced by pressing S1 or S2 button)</li> </ul>
Loop wire break or decrease in signal field	<b>RED</b>	<ul style="list-style-type: none"> <li>• Steady red light</li> </ul>	<ul style="list-style-type: none"> <li>• Constant beeping (Can be silenced by pressing S1 or S2 button)</li> </ul>
Defective backup battery	<b>RED</b>	<ul style="list-style-type: none"> <li>• Steady red light</li> </ul>	<ul style="list-style-type: none"> <li>• Chirp every 5 seconds (Can be silenced by pressing S1 or S2 button)</li> </ul>

Primary power: Primary power to the unit shall be provided by:

**ICT 801 Transmitter: AC Adapter Model 100-0020-01**

**ICT 802 Transmitter: AC Adapter Model 100-0018-01**

**ICT 810 Transmitter: AC Adapter Model 100-0018-01**

Backup Battery power: The ICT 801, ICT 802, and ICT 810 Transmitters can continue to function in the event of a power outage when connected to a fully charged backup battery system. A fully charged 12VDC battery with a 5.0Ah (Amp hours) rating provides enough power to the system for approximately 10 hours with the signal field set to the maximum width. Conversely, the narrower the signal field is set, the longer the battery will continue to power the system.

**Invisible Fence® Brand Backup Battery Model 10-900-0040-01 must be used.**

The ICT 801, ICT 802, and ICT 810 Transmitters are designed so the battery backup system is not necessary for normal operation. **If a backup battery is not installed, the Batt. Fault system indicator LED on the transmitter circuit board will be ON.**



**IMPORTANT:** The recommended battery has a limited shelf life and should be replaced every five years. The approved 5.0Ah battery (Model 10-900-0040-01) will take up to 50 hours to charge to full power.

## Setting the Signal Field Width

The signal field width is what activates the R21 v4.0 Titanium Computer Collar<sup>®</sup>. The signal field can be set to various distances from the signal field wire. The distance from the wire loop to the edge of the signal field is called the signal field width.

There is one signal field adjustment knob on ICT 801 and ICT 810 transmitters and two signal field adjustment knobs on the ICT 802 transmitter. See page 5, 6, or 7 as appropriate for location of signal field adjustment knobs. Turning the signal field adjustment knob clockwise increases the signal field width. Conversely, turning it counter-clockwise decreases the signal field width.



**IMPORTANT:** These adjustments do not change the correction level of the Invisible Fence<sup>®</sup> Brand R21 v4.0 Titanium Computer Collar<sup>®</sup> receiver, it only changes the width of the signal field.



You can check the width of the signal field by holding the Invisible Fence<sup>®</sup> Brand R21 v4.0 Titanium Computer Collar<sup>®</sup> receiver so that it is parallel to the signal field wire. Hold the collar so the receiver is about the same height and at the same angle as it will be when the pet is wearing it. Walk slowly toward the signal field wire. The receiver will activate when it is at the edge of the signal field.



**IMPORTANT:** Invisible Fence<sup>®</sup> Brand R21 v4.0 Titanium Computer Collar<sup>®</sup> receivers have a fail-safe mechanism. Should the pet become caught in the signal field, the receiver will go through three cycles of 10 seconds ON, 10 seconds OFF, and then shut down. The collar will not reactivate until it is completely removed from the signal field, and then brought back into it.

## Setting the Break-Alert<sup>®</sup> Detection Level:

The Break Alert<sup>®</sup> alarm can be set to make a sound when the signal field width is reduced by 25% or more of the set signal field width.

**Read entire procedure before performing. Only the loops turned on will be programmed.**

**Option #1:** To set the Break Alert<sup>®</sup> to activate when a 25% reduction in set signal field width occurs:

1. Set the signal field width for desired system operation.
2. If battery backup is being used, remove 12VDC battery power wire harness from transmitter connector J2 (see picture below).
3. Remove 12VAC power from transmitter connector J1.
4. Press and hold S2 button while reconnecting 12VAC power back to transmitter connector J1.
5. Continue holding S2 button for approximately five more seconds.
6. Release S2 button.
7. Break Alert<sup>®</sup> levels are now set. Setting will remain in memory even after power is removed.
8. Reconnect battery backup wire harness to transmitter connector J2, if applicable.

**Option #2:** To set the Break Alert<sup>®</sup> to activate at more than a 25% reduction in set signal field width:

1. Set the initial signal field width to the desired operational signal field width. Note the position of the indicator on the adjustment device.
2. Now adjust the signal field width to **less than** the desired operational signal field width.
3. Complete steps 2 – 6 under Option #1.
4. Adjust the signal field width to the **desired** operational field width.
5. Break Alert<sup>®</sup> levels are now set. Setting will remain in memory even after power is removed.

**Option #3:** To set the Break Alert<sup>®</sup> level back to the default settings (less than 1 foot).

1. Set the signal field width to the lowest setting (turn signal field adjustment all the way counterclockwise).
2. Complete steps 2 – 6 under Option #1.
3. Set the signal field width to the desired operational field width.
4. Break Alert<sup>®</sup> levels are now set. Setting will remain in memory even after power is removed.

 **IMPORTANT:** During a wire break, the alarm sounds and the Saturation LED L1 and/or L2 will light to notify which loop the break is on. The alarm will also sound if the signal field adjustment setting is below the programmed Break Alert<sup>®</sup> level.

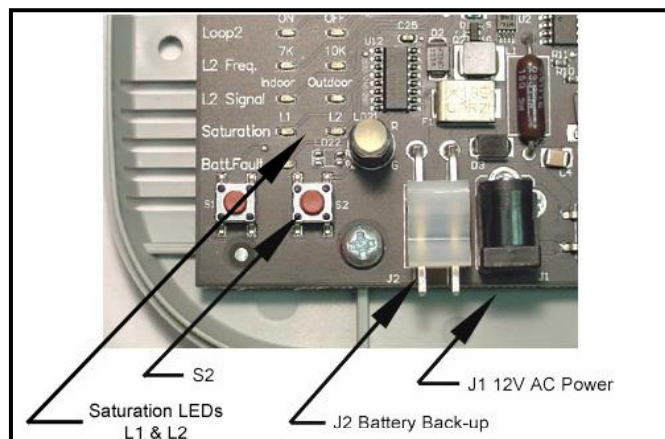

## R21 v4.0 Titanium Computer Collar® Receiver

Invisible Fence® Brand Computer Collar® receivers are microprocessor-controlled units powered by a Power Cap® battery .

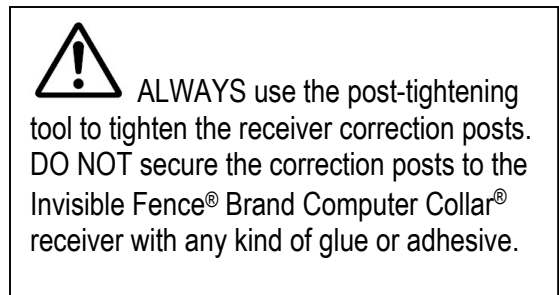
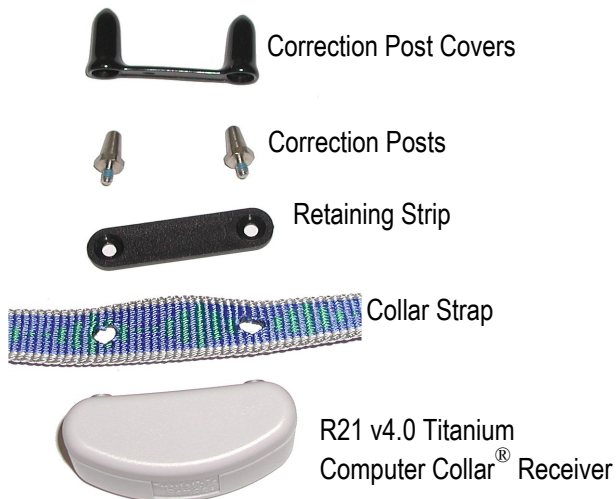

**Fitting the Invisible Fence® Brand Titanium Computer Collar® receiver on the Pet:**  
To work properly, the correction posts on the Invisible Fence® Brand Computer Collar® receiver must touch the pet's skin.

1. Position the Invisible Fence® Brand Computer Collar® receiver high up on the pet's neck with the receiver under its lower jaw.
2. To avoid having a collar that is too tight on a thick-haired pet, thin some hair away to make skin contact with the correction posts. DO NOT shave the pet's neck.
3. Tighten the strap of the Invisible Fence® Brand Computer Collar® receiver appropriately. Adjust the collar so it is snug enough to slide one finger between the correction post and the pet's neck.
4. The fit of the Invisible Fence® Brand Computer Collar® receiver should be adjusted as necessary as the pet's coat, weight, and age change.
5. Allow the pet to become accustomed to its new Invisible Fence® Brand Computer Collar® receiver. The collar should be removed each night during the first month of training and regularly thereafter. This ensures proper fit and avoids the possibility of skin irritation from the correction posts.

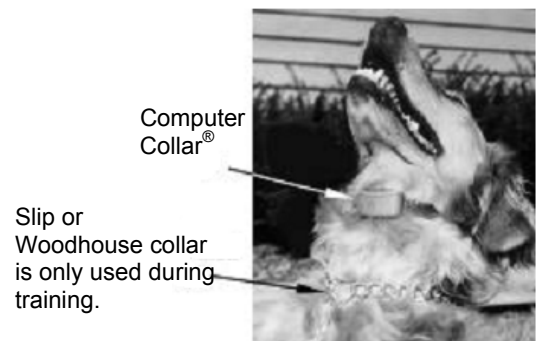

# Invisible Fence® Brand R21 v4.0 Titanium Computer Collar®

## Power Cap® Battery Status:

The ICT 801, ICT 802, and ICT 810 Transmitters utilize the R21 v4.0 Titanium Computer Collar® receiver. This receiver monitors Power Cap® battery status and will alert the owner when the Power Cap® battery needs to be replaced. A Power Cap® battery test is also performed each time it is inserted into the Computer Collar® receiver.

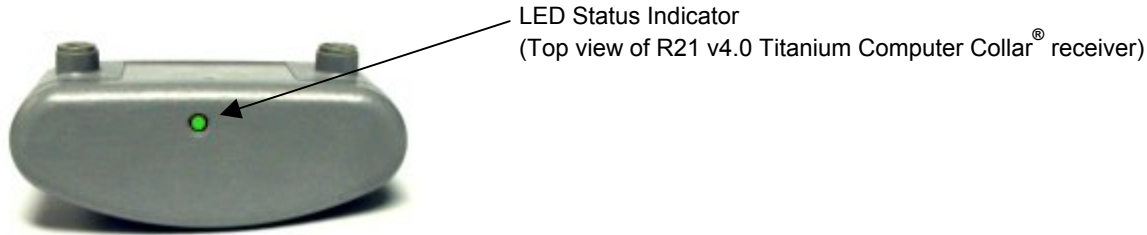

When the Power Cap® battery is inserted:

The LED status indicator shows GREEN for up to 1 second while testing, and then blinks (4 times) one of the following 3 colors to indicate the Power Cap® battery status:

- GREEN = Power Cap® battery is good.
- YELLOW = Replace the Power Cap® battery.
- RED = Replace NOW! Do not rely on the Invisible Fence® Brand system to contain the pet. The owner must become familiar with the Power Cap® battery status indicators.



R21 v4.0 Titanium Computer Collar® Status Light Indicator		
LED Indicator	Condition	Action Required
No light	Power Cap® is good	<ul style="list-style-type: none"> <li>• No Action Required</li> </ul>
Flashing Yellow	Power Cap® is low	<ul style="list-style-type: none"> <li>• Replace Power Cap® - The Power Cap® has lost most of its power.</li> </ul>
Flashing Red	Power Cap® is dead	<ul style="list-style-type: none"> <li>• DO NOT RELY ON THE INVISIBLE FENCE® BRAND SYSTEM TO KEEP THE PET CONTAINED!</li> <li>• Replace the Power Cap®</li> <li>• When a replacement Power Cap® is installed and signal field checked, the Invisible Fence® Brand System is ready for pet containment.</li> </ul>



For detailed instructions on how to program the R21 v4.0 Titanium Computer Collar® receiver, please refer to the CF-2200 Programming Tool Manual.

## Changing the Power Cap® Battery:

1. Use a small, thin coin to remove the Power Cap® battery from the R21 v4.0 Titanium Computer Collar® receiver. Insert the coin in the slot on top of the Power Cap® battery and turn it counter-clockwise. **Do not push down while turning.** The Power Cap® battery will rotate **up** and **out** of the R21 v4.0 Titanium Computer Collar® receiver's battery chamber.
2. Install a new Power Cap® battery using the following steps:
  - a. Line up the lugs on each side of the bottom of the Power Cap® battery with the grooves in the sides of the R21 v4.0 Titanium Computer Collar® receiver's battery chamber. Make sure the metal tabs on the bottom of the Power Cap® battery are not bent.
  - b. Place the Power Cap® battery into the chamber while gently, but firmly, turning it clockwise with your fingers.
  - c. Use a small, thin coin in the slot on top of the Power Cap® battery to turn it clockwise until the slot on the top of the Power Cap® battery is lined up with the two small raised tabs on the bottom of the receiver. **Do not over tighten by turning the slot past the tabs on the receiver.**

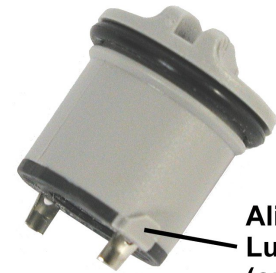

Alignment  
Lug  
(one on  
each side)



On average, the Power Cap® battery should be changed every 3 months. Low temperatures, the number of times the pet challenges the system boundary, and improper collar fit can all reduce Power Cap® battery life.



**Warning:** The use of any power source other than a Power Cap® battery will cause the receiver to operate erratically or fail. Failure of the receiver due to the use of an unauthorized power source will result in denial of a warranty claim.

The use of unnecessary force may damage the case and render the Power Cap® battery inoperable. NEVER open a Power Cap® battery, dispose of it in fire, recharge it, heat it above 212°F (100°C), or expose its contents to water. Doing so can cause leakage or explosion and may lead to personal injury.



**FCC ID# KZ3050261** "This device complies with Part 15 of the FCC Rules. Operation is subject to the following two conditions: 1) This device may not cause harmful interference, and 2) This device must accept any interference received, including interference that may cause undesirable operation. Changes or modifications not expressly approved by the party responsible for compliance could void the user's authority to operate the equipment."

**INDUSTRY CANADA CERTIFIED**  
Canada 2430A-050261

---