

DATE	REVISION NUMBER	INITIALS	DESCRIPTION
01/15/08	245-01616-010	TK	Initial design
03/05/08	245-01616-010	JL	Pin name modifications Board number to HB95
08/01/08	245-01616-020	JC	1.Q1 change SOT89 package 2. re-dispose component location
10/01/08	245-01616-030	JC	1.Q1 change SOT23 package,C133 change 10uF,R23 change 2.7K,C19 change 1uF,C27 change 1000pF, C28 change 100pF,C39 change 0.01uF,C29 change 0.01uF,C23 change 0.01uF, C20 change 0.01uF, C1 C2 change 22pF,C5 change 3.3pF,C6 C7 C11 change 10pF,C8 C9 C10 change 2pF,L1 L2 change 2nH, C13 C14 change 4.7pF,L5 change 2.2nH, C15 change 1.5pF 2.Add R26,C16,L6,C32,C40,C41
10/29/08	245-01616-040	JC	1.Add C42, C43, VR1, D1, R27 2.C34 from 1u change 0.1u, C41 from 1p change 1.5p, C6 C7 from 4.7p change 10p, R19 change NC L1 L2 from 2n change 2.2n, C8 C9 C10 C16 from 2p change 1.5p, C5 from 3p change 2p C31 C35 from 4.7u change 2.2u, C28 from 100p change 102p 3.Remove R25, C33, C29, Q1, R20
11/10/08	245-01616-050	JC	1.Add C43, R20, R25, Q1 2.C5 from 2p change 2.2p, C11 from 10p change 0ohm 3.Remove VR1
11/13/08	245-01616-060	JC	1.Add VR1, L3, C44, R27, R28, C33, R19 2.R20 from 10ohm change 5.1ohm/1206, C31 from 2.2u change 1u, Q1 change NC, 3.Remove C43, R25

# HB95- 802.11n Half-sized PCI Express Card Reference Design

**ATHEROS CONFIDENTIAL  
PRELIMINARY**

 <b>Atheros Communications, Inc.</b> 5480 Great America Parkway Santa Clara, CA 95054	Title			HB95 - Title Page							
	Date	Friday, November 14, 2008	Size	B	Rev	000	Sheet	1	of	3	DWG NO

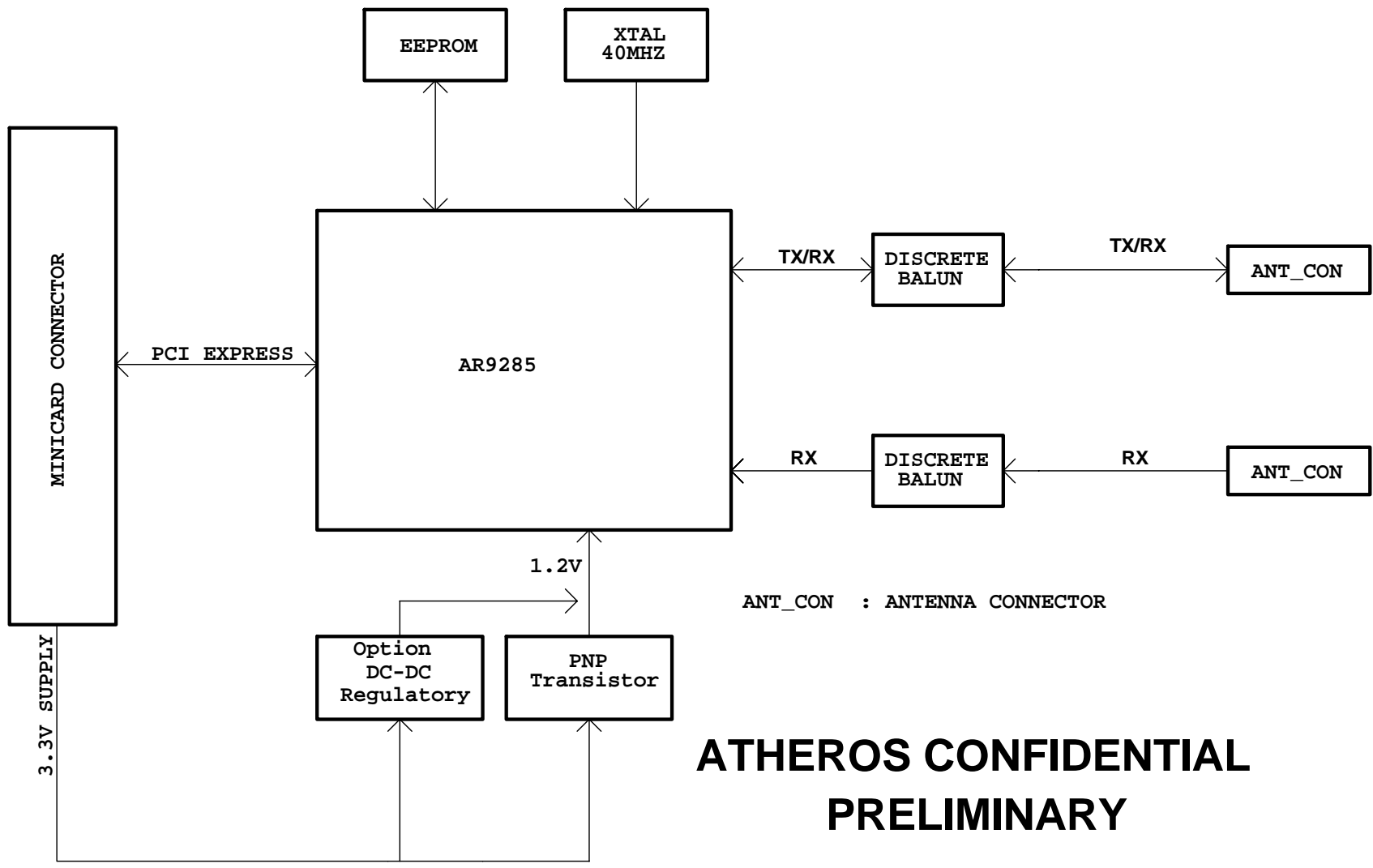

ANT\_CON : ANTENNA CONNECTOR

**ATHEROS CONFIDENTIAL  
PRELIMINARY**

 <b>Atheros Communications, Inc.</b> 5480 Great America Parkway Santa Clara, CA 95054				Title <b>HB95 - Block Diagram</b>	
Date	Wednesday, November 12, 2008	Size	B	Rev	000
Sheet	2	of	3	DWG NO <b>HB95-245-01616-060</b>	

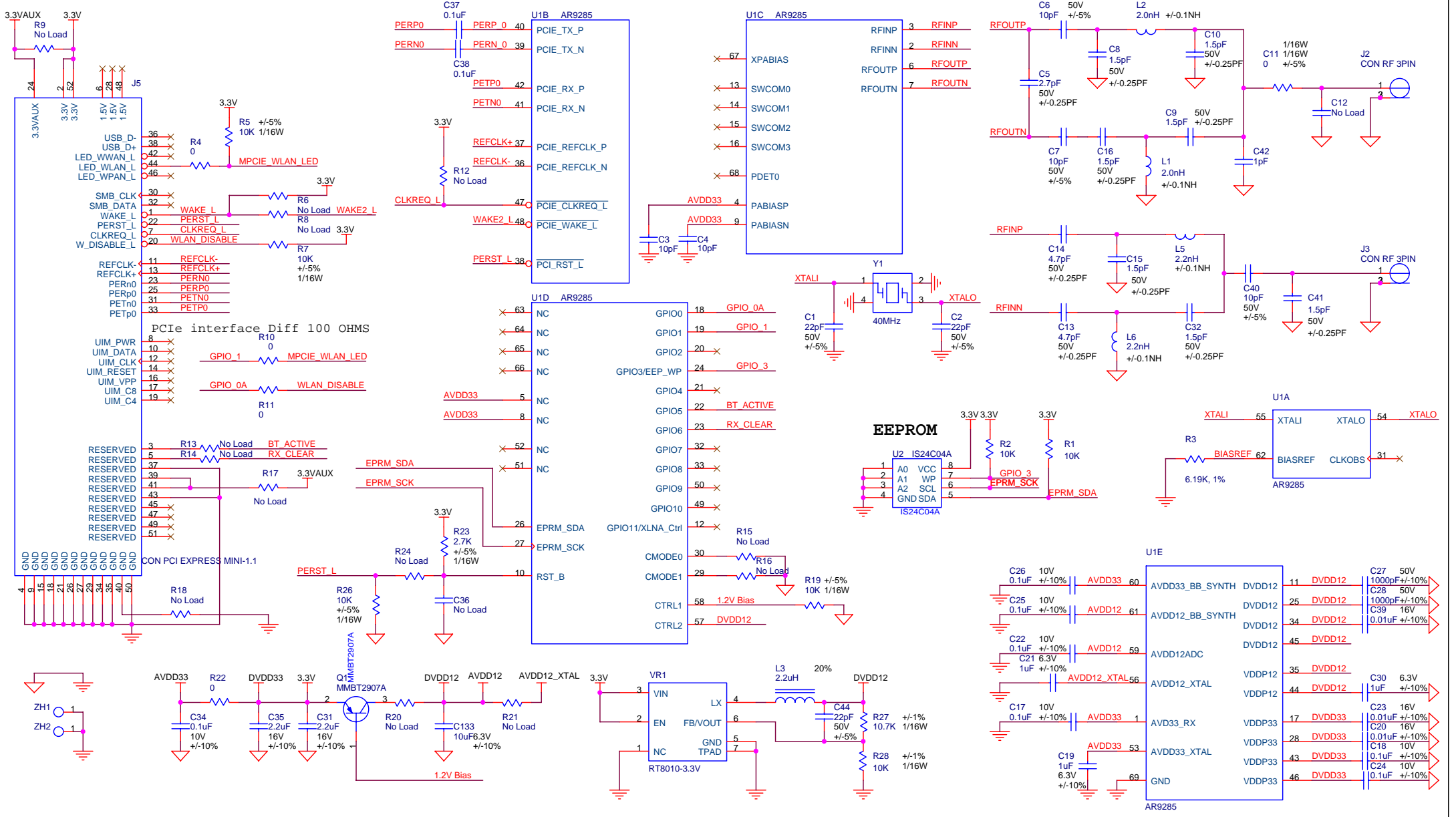

**ATHEROS CONFIDENTIAL  
PRELIMINARY**