

# CEILING FAN REMOTE CONTROLLER OPERATION AND INSTALLATION INSTRUCTIONS

(Please keep this instruction pamphlet.)

## IMPORTANT

YOU MUST SET CEILING FAN MANUAL SWITCH TO HIGH SPEED AND LIGHT KIT (IF ANY) TO ON POSITION BEFORE OPERATING REMOTE CONTROL.

## IMPORTANT POINTS TO REMEMBER:

1. Read and save these instructions.
2. Please note that all fixed wiring appliances should be installed by a qualified electrician.
3. The supply to the remote control receiver should be connected through a mains switch, i.e. existing wall switch.
4. Disconnect from power supply at wall switch before working on remote control receiver or ceiling fan.
5. Install receiver into the ceiling fan canopy of the fan to ensure proper protection.
6. This unit is to be used for the control of ceiling fan and in a AC110/120V 60Hz power supply only.
7. Do not install in damp locations or immerse in water. (For indoor use only.)
8. Do not pull on or cut leads shorter.
9. Do not drop or bump the unit.
10. PLEASE NOTE: The battery will weaken with age and should be replaced before leaking takes place as this will damage the transmitter. Dispose of used battery properly, keep the battery out of reach of children.
11. CAUTION: To reduce the risk of fire or injury, do not use this product in conjunction with any variable (rheostat) wall control.

## INSTALLATION INSTRUCTIONS

CAUTION: INCORRECT WIRE CONNECTION WOULD DAMAGE THIS RECEIVER.

1. Ceiling fan must be set at HIGH speed and light kit (If any) at ON position by pressing the "Light Switch" after installation.
2. Once the connection has been made, the receiver inserts into the drop rod hanging bracket. The canopy comes up to cover the receiver and bracket.

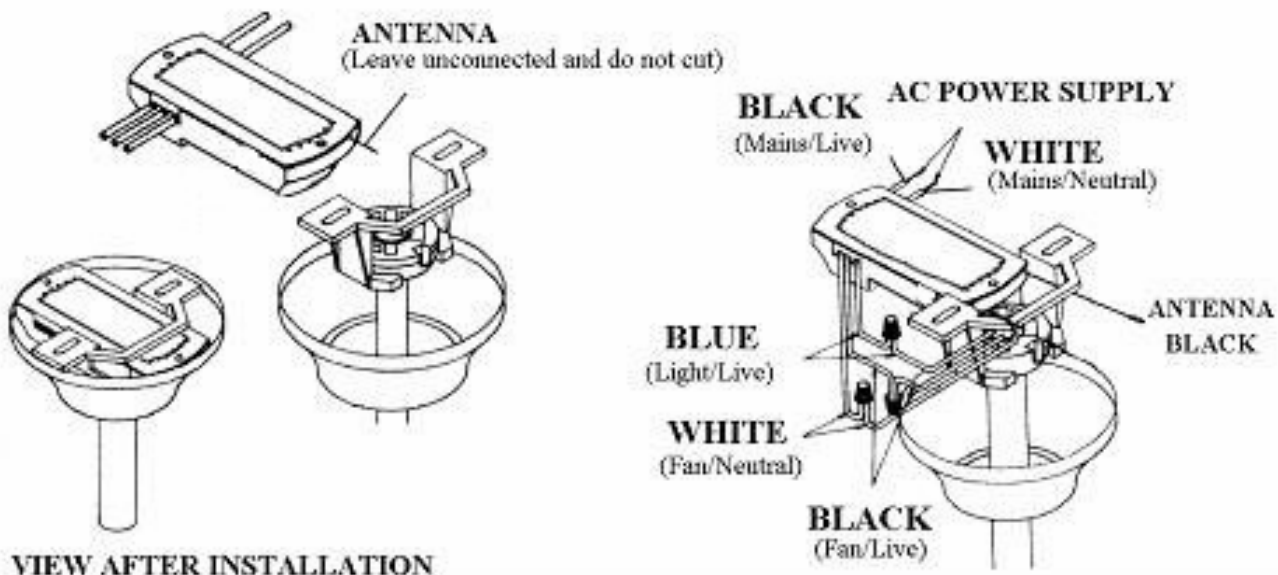

# CODE SWITCH

- 1.CODE SWITCH: Codes are set by pushing dip switches up or down. It is imperative that the code used for both transmitter and receiver is exactly the same, otherwise remote controller will not work. Please note the code switch will enable you to operate a second remote controller independently. For example, if you have two ceiling fans with 2 remote control units, set 2 different codes for each set of transmitter/receivers. This means you can operate each ceiling fan independently.
- 2.Your remote control is ready for use after battery installation.

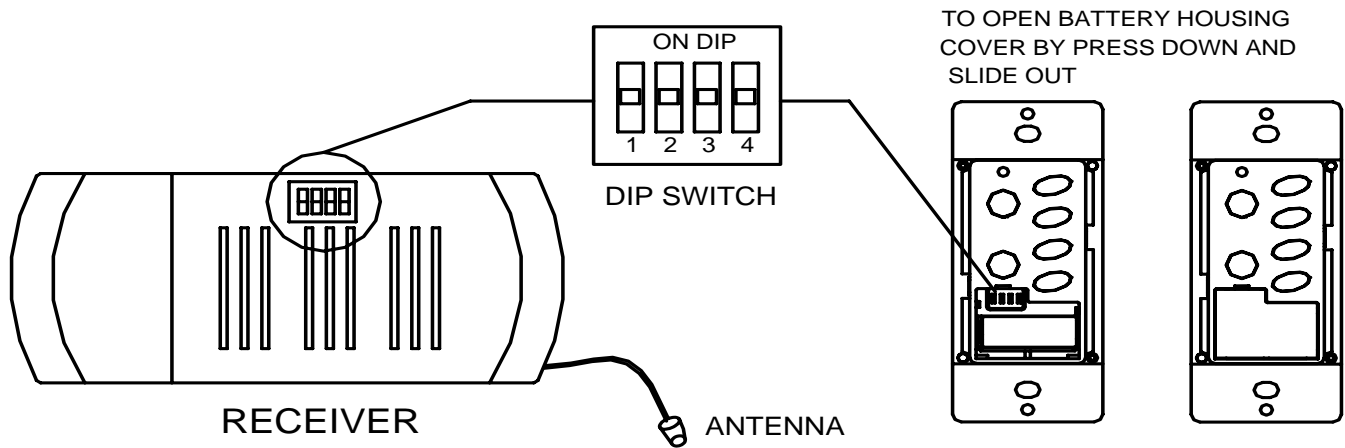

## FUNCTIONS OF TRANSMITTER

- OFF :Turn off the fan.
- HI :Turn on the fan at high speed.
- MED :Turn on the fan at medium speed
- LOW :Turn on the fan at low speed
- LIGHT :The first press and release immediately to turn on the up light and turn off the down light. The second press and release immediately to turn on the up light and down light, The third press and release immediately to turn off the up light and down light, The fourth press and release immediately to turn off the up light and turn off the down light
- F/R: Press the key ,the fan will run in Reverse direction

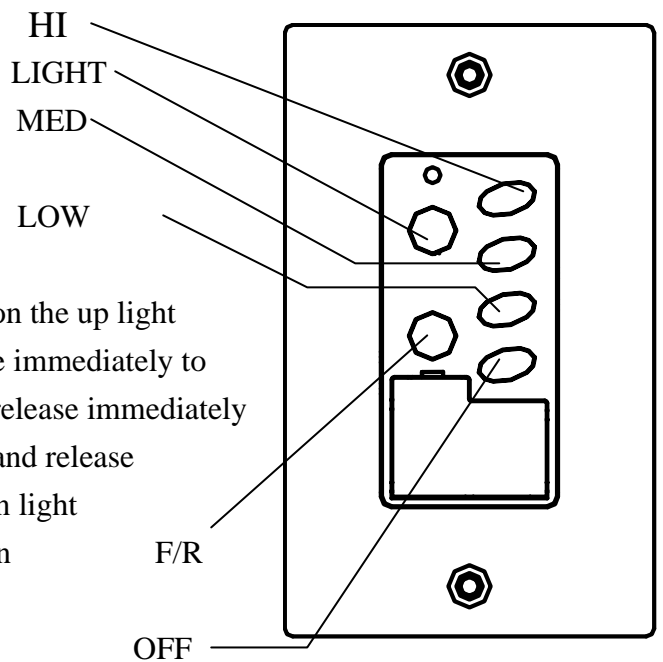

*Ceiling Fan Remote Control  
Wiring Connection*

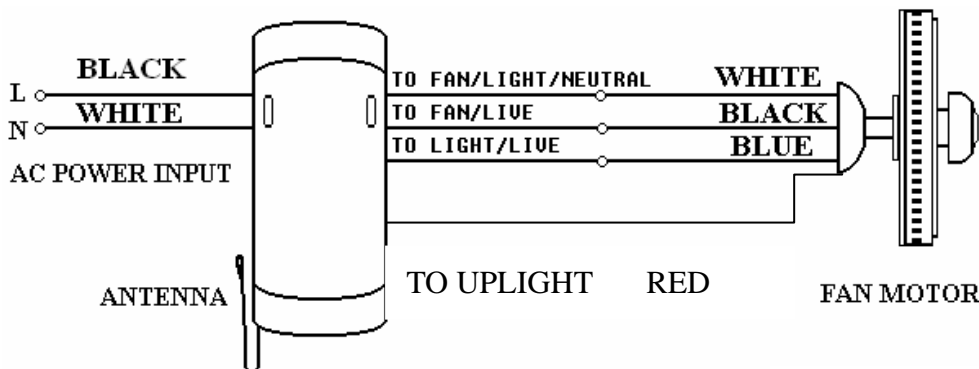

Installation of Transmitter  
Wall Mount Holder with  
two screws.

**FEDERAL COMMUNICATIONS COMMISSION  
INTERFERENCE STATEMENT**

This equipment has been tested and found to comply with the limits for a Class B digital device, pursuant to Part 15 of the FCC Rules. These limits are designed to provide reasonable protection against harmful interference in a residential installation. This equipment generates, uses and can radiate radio frequency energy and, if not installed and used in accordance with the instructions, may cause harmful interference to radio communications. However, there is no guarantee that interference will not occur in a particular installation. If this equipment does cause harmful interference to radio or television reception, which can be determined by turning the equipment off and on, the user is encouraged to try to correct the interference by one or more of the following measures:

- Reorient or relocate the receiving antenna.
- Increase the separation between the equipment and receiver.
- Connect the equipment into an outlet on a circuit different from that to which the receiver is connected.
- Consult the dealer or an experienced radio/TV technician for help.

**CAUTION:**

**To assure continued FCC compliance:**

Any changes or modifications not expressly approved by the grantee of this device could void the user's authority to operate the equipment.

**FCC ID : KUJCE9802**

This device complies with Part 15 of the FCC Rules. Operation is subject to the following two conditions: (1) This device may not cause harmful interference, and (2) this device must accept any interference received, including interference that may cause undesired operation.