

CEILING FAN REMOTE CONTROLLER OPERATION AND INSTALLATION INSTRUCTIONS

(Please keep this instruction pamphlet.)

IMPORTANT

YOU MUST SET CEILING FAN MANUAL SWITCH TO HIGH SPEED AND LIGHT KIT (IF ANY) TO ON POSITION BEFORE OPERATING REMOTE CONTROL.

IMPORTANT POINTS TO REMEMBER:

1. Read and save these instructions.
2. Please note that all fixed wiring appliances should be installed by a qualified electrician.
3. The supply to the remote control receiver should be connected through a mains switch, i.e. existing wall switch.
4. Disconnect from power supply at wall switch before working on remote control receiver or ceiling fan.
5. Install receiver into the ceiling fan canopy of the fan to ensure proper protection.
6. This unit is to be used for the control of ceiling fan and in an AC110V/120V 60Hz power supply only.
7. Do not install in damp locations or immerse into water. (For indoor use only.)
8. Do not pull on or cut leads shorter.
9. Do not drop or bump the unit.
10. PLEASE NOTE: The battery will weaken with age and should be replaced before leaking takes place as this will damage the transmitter. Dispose of used battery properly, keep the battery out of reach of children.
11. CAUTION: To reduce the risk of fire or injury, do not use this product in conjunction with any variable (rheostat) wall control.

INSTALLATION INSTRUCTIONS

CAUTION: INCORRECT WIRE CONNECTION WOULD DAMAGE THIS RECEIVER.

1. Ceiling fan must be set at HIGH speed and light kit (If any) at ON position by pulling the "Pull Switch" after installation.
2. Once the connection has been made, the receiver inserts into the drop rod hanging bracket. The canopy comes up to cover the receiver and bracket.

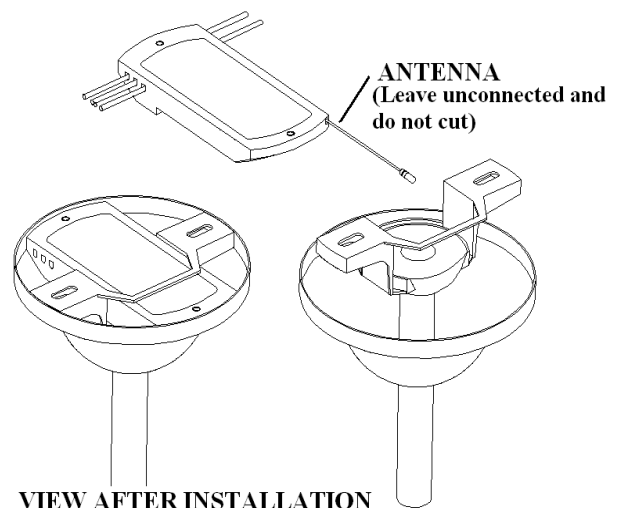
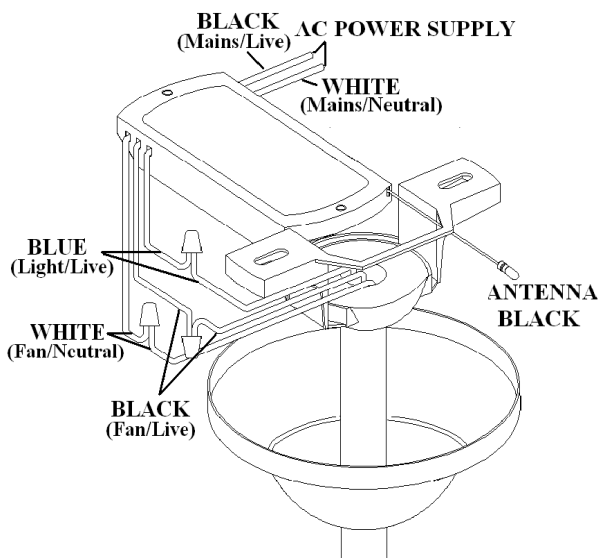

LEARNING PROCESS

1. After installing the unit and power on, open battery cover (with battery, DC1.5V/ AAA*2pcs, installed), use a ball pen to press and hold the "LEARN" key 1~3seconds. LIGHT will blink 3 times then turn off and FAN turn on at high speed, which indicate that learning process finished. Please note that must press the "LEARNING KEY" within 30 seconds after power on. If just replace batteries, no need to re-learn.
2. Please note that the transmitter can learn in multiple receiver, when doing learning process please make sure not learn in other receiver.

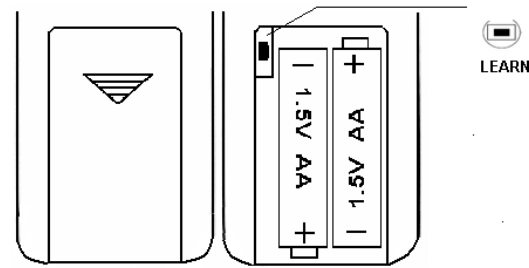

NOTE: The transmitter and receiver had completed learning setting when in ex-factory. You don't need to execute the LEARNING PROCESS until replace a new transmitter or interfered from other remote units

FUNCTIONS OF TRANSMITTER

HI : Turn on the fan at high speed

MED : Turn on the fan at medium speed

LOW : Turn on the fan at low speed

OFF : Turn off the ceiling fan.

FAN 3Hrs : Setting up that the ceiling fan will off power after 3 hours automatically.

LIGHT ON/OFF: Press and release immediately to turn on or off the light

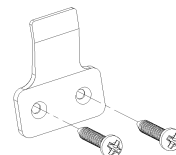

Installation of transmitter wall mount holder with two screws.

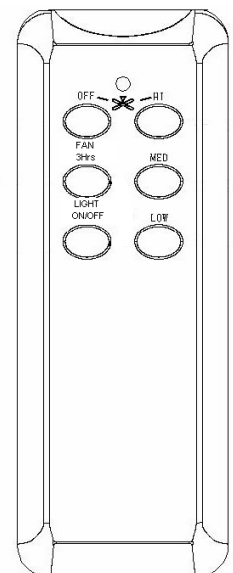

TR106A

To assure continued FCC compliance:

FEDERAL COMMUNICATIONS COMMISSION INTE

This equipment has been tested and found to comply with the limits for a Class B digital device, pursuant to Part 15 of the FCC Rules. These limits are designed to provide reasonable protection against harmful interference in a residential installation. This equipment generates, uses and can radiate radio frequency energy and, if not installed and used in accordance with the instructions, may cause harmful interference to radio communications. However, there is no guarantee that interference will not occur in a particular installation. If this equipment does cause harmful interference to radio or television reception, which can be determined by turning the equipment off and on, the user is encouraged to try to correct the interference by one or more of the following measures:

- Reorient or relocate the receiving antenna.
- Increase the separation between the equipment and receiver.
- Connect the equipment into an outlet on a circuit different from that to which the receiver is connected.
- Consult the dealer or an experienced radio/TV technician for help.

CAUTION:

To assure continued FCC compliance:

Any changes or modifications not expressly approved by the grantee of this device could void the user's authority to operate the equipment.

FCC ID : KUJCE10511

This device complies with Part 15 of the FCC Rules. Operation is subject to the following two conditions: (1) This device may not cause harmful interference, and (2) this device must accept any interference received, including interference that may cause undesired operation.