

APPLICATION FOR CERTIFICATION

On Behalf of

Chungear Industrial Co., Ltd.

Ceiling Fan Remote Controller

Model No. : MR101F

FCC ID : KUJCE10201

Prepared for : Chungear Industrial Co., Ltd.
106 Kanho Rd., Taichung, Taiwan

Prepared by : AUDIX Technology Corporation
EMC Department
No. 53-11, Dingfu, Linkou Dist.,
New Taipei City 244, Taiwan, R.O.C.

Tel : (02) 2609-9301, 2609-2133
Fax: (02) 2609-9303

File Number : C1M1307126
Report Number : EM-F1020564
Date of Test : Aug. 05 ~ 10, 2013
Date of Report : Aug. 14, 2013

TABLE OF CONTENTS

Description	Page
TEST REPORT CERTIFICATION	4
1. GENERAL INFORMATION	5
1.1. Description of Device (EUT).....	5
1.2. Tested Supporting System Details.....	6
1.3. Description of Test Facility	6
1.4. Measurement Uncertainty.....	7
2. CONDUCTED EMISSION MEASUREMENT	8
2.1. Test Equipment.....	8
2.2. Block Diagram of Test Setup.....	8
2.3. Powerline Conducted Emission Limit (§15.207, Class B)	8
2.4. Operating Condition of EUT	9
2.5. Test Procedure	9
2.6. Powerline Conducted Emission Measurement Results.....	9
3. RADIATED EMISSION MEASUREMENT	12
3.1. Test Equipment.....	12
3.2. Test Setup	12
3.3. Radiated Emission Limits (§15.209)	14
3.4. Operating Condition of EUT	14
3.5. Test Procedure	15
3.6. Test Results.....	16
4. 6dB BANDWIDTH MEASUREMENT	28
4.1. Test Equipment.....	28
4.2. Block Diagram of Test Setup.....	28
4.3. Specification Limits [§15.247(a)(2)]	28
4.4. Operating Condition of EUT	28
4.5. Test Procedure	28
4.6. Test Results.....	29
5. MAXIMUM PEAK OUTPUT POWER MEASUREMENT	32
5.1. Test Equipment.....	32
5.2. Block Diagram of Test Setup.....	32
5.3. Specification Limits [§15.247(b)-(3)].....	32
5.4. Operating Condition of EUT	32
5.5. Test Procedure	32
5.6. Test Results.....	33
6. EMISSION LIMITATIONS MEASUREMENT	34
7. BAND EDGES MEASUREMENT	35
7.1. Test Equipment.....	35
7.2. Block Diagram of Test Setup.....	35
7.3. Specification Limits [§15.247(c)].....	35
7.4. Operating Condition of EUT	35
7.5. Test Procedure	35
7.6. Test Results.....	36
8. POWER SPECTRAL DENSITY MEASUREMENT	37
8.1. Test Equipment.....	37
8.2. Block Diagram of Test Setup.....	37
8.3. Specification Limits [§15.247(d), RSS-210 §A8.2 (b)].....	37
8.4. Operating Condition of EUT	37
8.5. Test Procedure	37
8.6. Test Results.....	38
9. DEVIATION TO TEST SPECIFICATIONS.....	41

10. PHOTOGRAPHS.....42
10.1. Photos of Conducted Emission Measurement 42
10.2. Photos of Radiated Measurement at Semi-Anechoic Chamber 43
10.3. Photo of Section RF Conducted Measurement..... 44

TEST REPORT CERTIFICATION

Applicant : Chungear Industrial Co., Ltd.
 Manufacturer #1 : Chungear Industrial Co., Ltd.
 Manufacturer #2 : Satellite Electronic (Zhongshan) Ltd.
 Manufacturer #3 : Zhongshan Amity Electronic Ltd.
 EUT Description : Ceiling Fan Remote Controller
FCC ID : KIJCE10201
 (A) Model No. : MR101F
 (B) Serial No. : N/A
 (C) Power Supply : AC 120V/60Hz
 (D) Test Voltage : AC 120V/60Hz

Measurement Procedure Used:

FCC Rules and Regulations Part 15 Subpart C, Oct. 2012
 (FCC CFR 47 Part 15C, §15.205, §15.207, §15.209)
 AND ANSI C63.4:2003

The device described above was tested by AUDIX Technology Corporation to determine the maximum emission levels emanating from the device. The maximum emission levels were compared to the FCC Part 15 subpart C limits.

The measurement results are contained in this test report and AUDIX Technology Corporation is assumed full responsibility for the accuracy and completeness of these measurements. Also, this report shows that the EUT to be technically compliant with the FCC official limits.

This report applies to above tested sample only. This report shall not be reproduced in part without written approval of AUDIX Technology Corporation.

Date of Test: Aug. 05 ~ 10, 2013

Date of Report: Aug. 14, 2013

Producer: Annie Yu
 (Annie Yu/Administrator)

Signatory: Leon Liu
 (Leon Liu/Deputy General Manager)

1. GENERAL INFORMATION

1.1. Description of Device (EUT)

Product	Ceiling Fan Remote Controller
Model Number	MR101F
Serial Number	N/A
Applicant	Chungear Industrial Co., Ltd. 106 Kanho Rd., Taichung, Taiwan
Manufacturer	#1 Chungear Industrial Co., Ltd. 106 Kanho Rd., Taichung, Taiwan #2 Satellite Electronic (Zhongshan), Ltd. No.15, Torch Hi-Tech Industrial Development Zone, Zhong Shan City Guangdong Province China #3 Zhongshan Amity Electronic Ltd. No. 16 Torch Hi-Tech Industrial Development Zone, Zhong Shan City Guangdong Province China
FCC ID	KIJCE10201
Fundamental Range	2402MHz ~ 2480MHz
Frequency Channel	40 channels
Radio Technology	DSSS
ANT Gain	6.03dBi(Peak), PCB Type
Power Wire	Non-Shielded, Undetachable, 0.11m*2
Data Transfer Rate	1/2/3Mbps
Date of Receipt of Sample	Jul. 11, 2012
Date of Test	Aug. 05 ~ 10, 2013

1.2. Tested Supporting System Details

1.2.1. TRANSFORMER

Model Number : R9211047
Serial Number : NLION1149
Power Wire*2 : Non-Shielded, Detachable, 0.3m
Power Cord : Non-Shielded, Detachable, 2.4m

1.2.2. REMOTE CONTROLLER

Model Number : TR158A
Serial Number : N/A
Manufacturer : Chungear Industrial Co., Ltd.

1.3. Description of Test Facility

Name of Firm : **AUDIX Technology Corporation**
EMC Department
No. 53-11, Dingfu, Linkou Dist.,
New Taipei City 244, Taiwan, R.O.C.

Test Site : **No. 8 Shielded Room &**
(C8/Semi-AC) No. 53-11, Dingfu, Linkou Dist.,
New Taipei City 244, Taiwan, R.O.C.
Semi-Anechoic Chamber
No. 53-11, Dingfu, Linkou Dist.,
New Taipei City 244, Taiwan, R.O.C.
May 14, 2009 Renewal on
Federal Communication Commission
Registration Number: 90993

NVLAP Lab. Code : 200077-0

TAF Accreditation No : 1724

1.4. Measurement Uncertainty

Test Item	Frequency Range	Uncertainty (dB)
Conduction Test	150kHz~30MHz	±1.73dB
Radiation Test (Distance: 3m)	30MHz~300MHz	± 2.91dB
	300MHz~1000MHz	± 2.74dB
	Above 1GHz	± 5.02dB

Remark : Uncertainty = $ku_c(y)$

Test Item	Uncertainty
6dB Bandwidth	± 0.05kHz
Maximum peak output power	± 0.33dBm
Emission Limitations	± 0.13dB
Band edges	± 0.13dB
Power spectral density	± 0.13dB

2. CONDUCTED EMISSION MEASUREMENT

2.1. Test Equipment

The following test equipment was used during the powerline conducted emission measurement: (No. 8 Shielded Room)

Item	Type	Manufacturer	Model No.	Serial No.	Last Cal.	Next Cal.
1.	Test Receiver	R&S	ESCS30	100265	Aug. 24, 13'	Aug. 23, 14'
2.	A.M.N.	R&S	ESH2-Z5	100366	Mar. 19, 13'	Mar. 18, 14'

2.2. Block Diagram of Test Setup

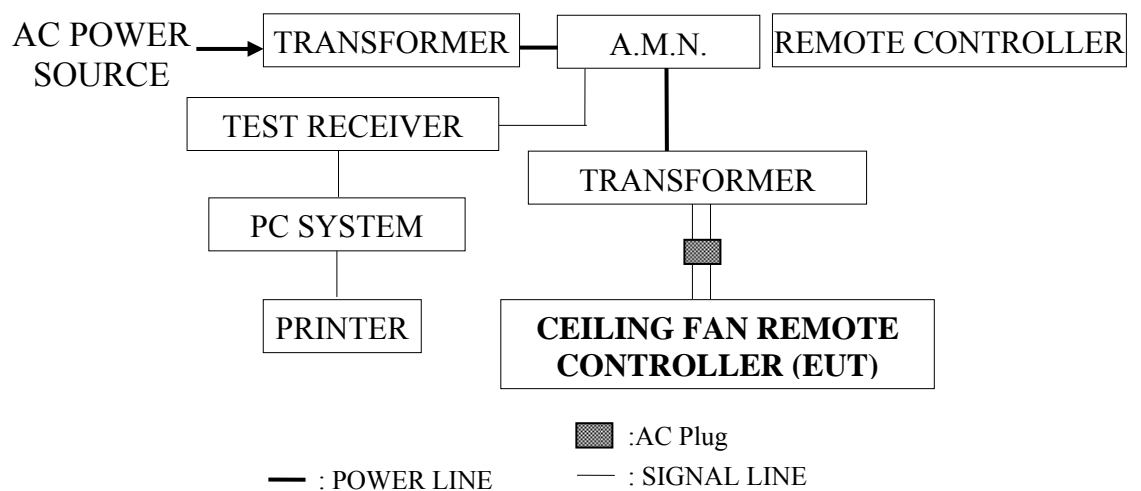

2.3. Powerline Conducted Emission Limit (§15.207, Class B)

Frequency	Maximum RF Line Voltage	
	Quasi-Peak Level	Average Level
150kHz ~ 500kHz	66 ~ 56 dB μ V	56 ~ 46 dB μ V
500kHz ~ 5MHz	56 dB μ V	46 dB μ V
5MHz ~ 30MHz	60 dB μ V	50 dB μ V

- Remark: 1. If the average limit is met when using a quasi-peak detector, the EUT shall be deemed to meet both limits and measurement with the average detector is unnecessary.
 2. The lower limit applies at the band edges.

2.4. Operating Condition of EUT

- 2.4.1. Setup the **EUT (Ceiling Fan Remote Controller)** as shown on 2.2.
- 2.4.2. Turn on the power of all equipment.
- 2.4.3. The **EUT (Ceiling Fan Remote Controller)** was on transmitting function with the remote controller at work during all testing.

2.5. Test Procedure

The EUT was placed on the table which was above the ground by 80cm and transformer's power cord connected to the AC mains through an Artificial Mains Network (A.M.N.). This provided a 50 ohm coupling impedance for the measuring equipment. (Please refer to the block diagram of the test setup and photographs.) Both sides of A.C. line were checked for maximum conducted interference. In order to find the maximum emission, the relative positions simulators of the interface cables should be manipulated according to ANSI C63.4-2003 regulation during conducted measurement.

The bandwidth of the R&S Test Receiver ESCS30 was set at 9kHz.

The frequency range from 150kHz to 30MHz was checked.

All the final readings from Test Receiver were measured with the Quasi-Peak detector and Average detector. Remark: If the Average limit is met when using a Quasi-Peak detector, the Average detector is unnecessary)

2.6. Powerline Conducted Emission Measurement Results

PASSED. All emissions not reported below are too low against the prescribed limits.

The EUT was measured during this section testing and all the test results are listed in next pages.

EUT : Ceiling Fan Remote Controller Model No. : MR101F

Test Date : Aug. 10, 2013 Temperature : 25 Humidity : 52%

The details are as follows :

Mode	Reference Test Data	
	Neutral	Line
1.	# 2	# 1



AUDIX TECHNOLOGY Corp. EMC Department
 No.53-11, Dingfu, Linkou Dist., New Taipei City
 24442, Taiwan R.O.C.
 Tel: +886-2-26092133 Fax: +886-2-26099303
 Email: emc@audixtech.com

Data: 2 File: D:\test data\REPORT\2013\1M1307XXX\1M1307126-C-D.EM6 (2)

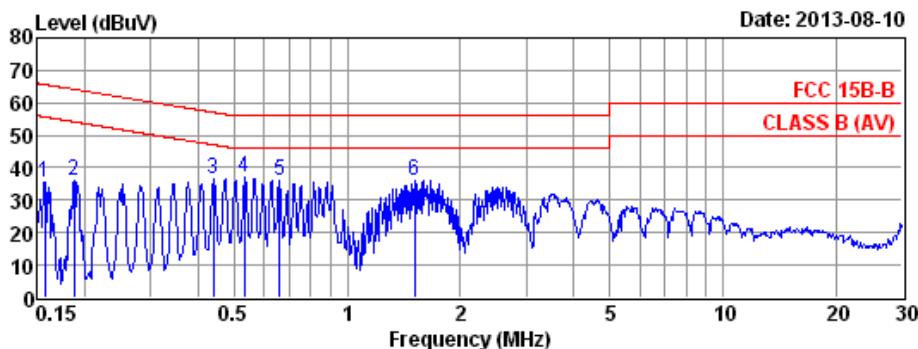

Site no. : No.8 Shielded Room Data no. : 2
 Dis. / Ant. : ESH2-Z5 366 Ant. pol. : NEUTRAL
 Limit : FCC 15B-B
 Env. / Ins. : 25°C / 52% ESCS (265) Engineer : Jack_Wu
 EUT : MR101F
 Power Rating : 120Vac/60Hz
 Test Mode : OPERATING

	Freq. (MHz)	AMI Factor (dB)	Cable Loss (dB)	Reading (dBμV)	Emission Level (dBμV)	Limits (dBμV)	Margin (dB)	Remark
1	0.156	0.10	0.04	35.61	35.75	65.65	29.90	QP
2	0.187	0.10	0.04	36.13	36.27	64.15	27.88	QP
3	0.440	0.11	0.04	36.67	36.82	57.07	20.25	QP
4	0.532	0.13	0.04	36.69	36.86	56.00	19.14	QP
5	0.661	0.15	0.04	36.07	36.26	56.00	19.74	QP
6	1.511	0.20	0.07	35.77	36.04	56.00	19.96	QP

Remarks: 1. Emission Level= AMI Factor + Cable Loss + Reading.
 2. If the average limit is met when using a quasi-peak detector, the EUT shall be deemed to meet both limits and measurement with average detector is unnecessary.



AUDIX TECHNOLOGY Corp. EMC Department
 No.53-11, Dingfu, Linkou Dist., New Taipei City
 24442, Taiwan R.O.C.
 Tel: +886-2-26092133 Fax: +886-2-26099303
 Email: emc@audixtech.com

Data: 1 File: D:\test data\REPORT\2013\1M1307XXX\1M1307126-C-D.EM6 (2)

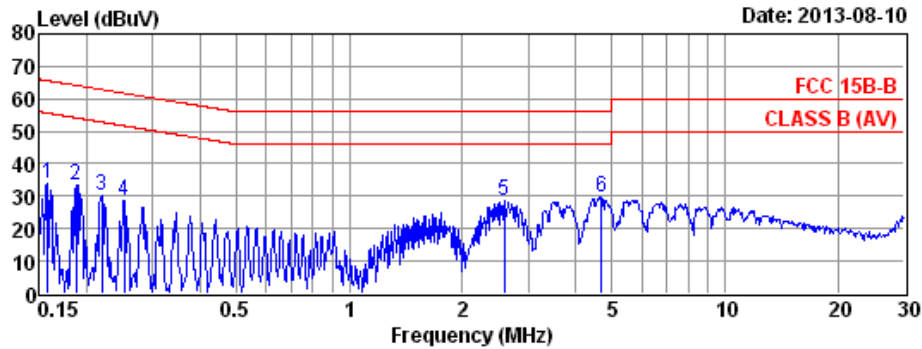

Site no. : No.8 Shielded Room Data no. : 1
 Dis. / Ant. : ESH2-Z5 366 Ant. pol. : LINE
 Limit : FCC 15B-B
 Env. / Ins. : 25°C / 52% ESCS (265) Engineer : Jack_Wu
 EUT : MR101F
 Power Rating : 120Vac/60Hz
 Test Mode : OPERATING

	Freq. (MHz)	AMI. Factor (dB)	Cable Loss (dB)	Reading (dBμV)	Emission Level (dBμV)	Limits (dBμV)	Margin (dB)	Remark
1	0.157	0.10	0.04	33.60	33.74	65.60	31.86	QP
2	0.187	0.10	0.04	33.12	33.26	64.15	30.89	QP
3	0.220	0.10	0.04	30.12	30.26	62.83	32.57	QP
4	0.252	0.10	0.04	28.69	28.83	61.69	32.86	QP
5	2.581	0.20	0.09	28.38	28.67	56.00	27.33	QP
6	4.696	0.22	0.13	29.57	29.92	56.00	26.08	QP

Remarks: 1. Emission Level= AMI Factor + Cable Loss + Reading.
 2. If the average limit is met when using a quasi-peak detector, the EUT shall be deemed to meet both limits and measurement with average detector is unnecessary.

3. RADIATED EMISSION MEASUREMENT

3.1. Test Equipment

The following test equipment was used during the radiated emission measurement:

3.1.1. For Frequency Range 30MHz~1000MHz (at Semi-Anechoic Chamber)

Item	Type	Manufacturer	Model No.	Serial No.	Last Cal.	Next Cal.
1.	Spectrum Analyzer	Agilent	E4446A	US44300366	Aug. 06, 13'	Aug. 05, 14'
2.	Test Receiver	R & S	ESCS30	100338	Jul. 01, 13'	Jun. 30, 14'
3.	Amplifier	HP	8447D	2944A06305	Feb. 19, 13'	Feb. 18, 14'
4.	Log Periodic Antenna	Schwarzbeck	UHALP 9108-A	0810	Mar. 02, 13'	Mar. 01, 14'
5.	Biconical Antenna	CHASE	VBA6106A	1264	Mar. 02, 13'	Mar. 01, 14'

3.1.2. For Frequency Above 1GHz (at Semi-Anechoic Chamber)

Item	Type	Manufacturer	Model No.	Serial No.	Last Cal.	Next Cal.
1.	Spectrum Analyzer	Agilent	E4446A	US44300366	Aug. 06, 13'	Aug. 05, 14'
2.	Test Receiver	R & S	ESCS30	100338	Jul. 01, 13'	Jun. 30, 14'
3.	Pre-Amplifier	HP	8449B	3008A02676	Mar. 01, 13'	Feb. 28, 14'
4.	2.4GHz Notch Filter	K&L	7NSL10-24 41.5E130.5 -00	1	Jun. 13, 13'	Jun. 12, 14'
5.	3.5G High Pass Filter	Microwave Circuits	H3G018G1	484796	Jun. 13, 13'	Jun. 12, 14'
6.	Horn Antenna	EMCO	3115	9112-3775	May 07, 13'	May 06, 14'
7.	Horn Antenna	EMCO	3116	2653	Oct. 15, 12'	Oct. 14, 13'

3.2. Test Setup

3.2.1. Block Diagram of connection between EUT and simulators

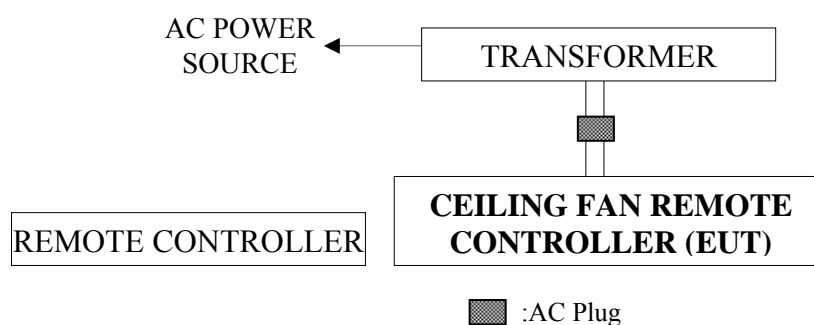

3.2.2. Semi-Anechoic Chamber (3m) Setup Diagram for 30-1000MHz

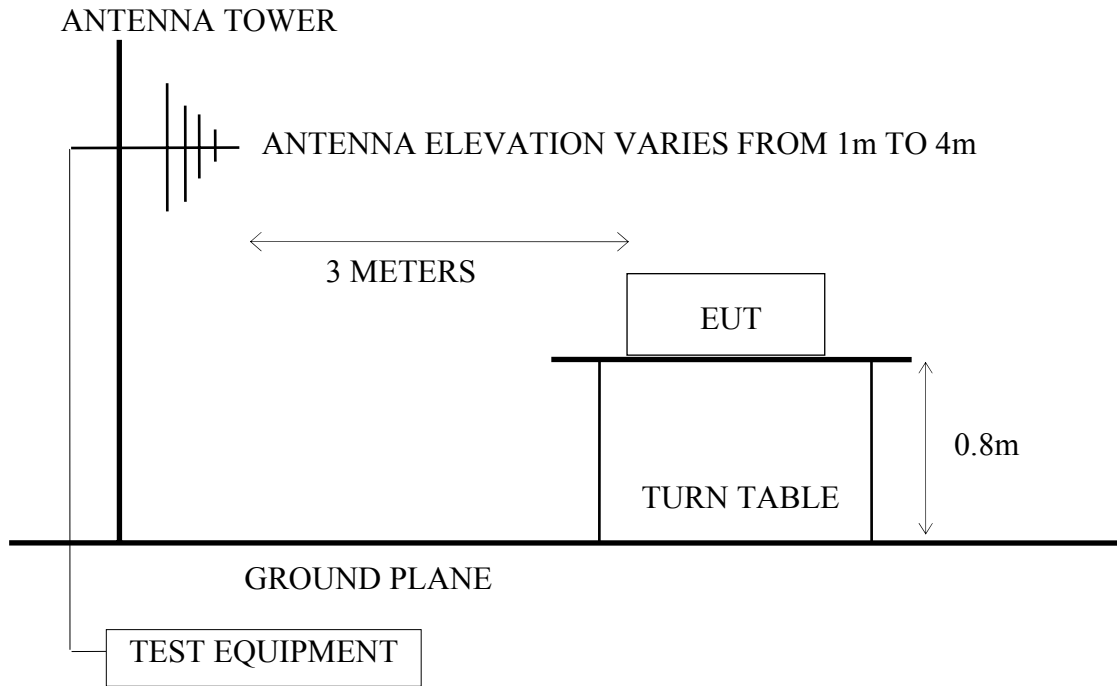

3.2.3. Semi-Anechoic Chamber (3m) Setup Diagram for above 1GHz

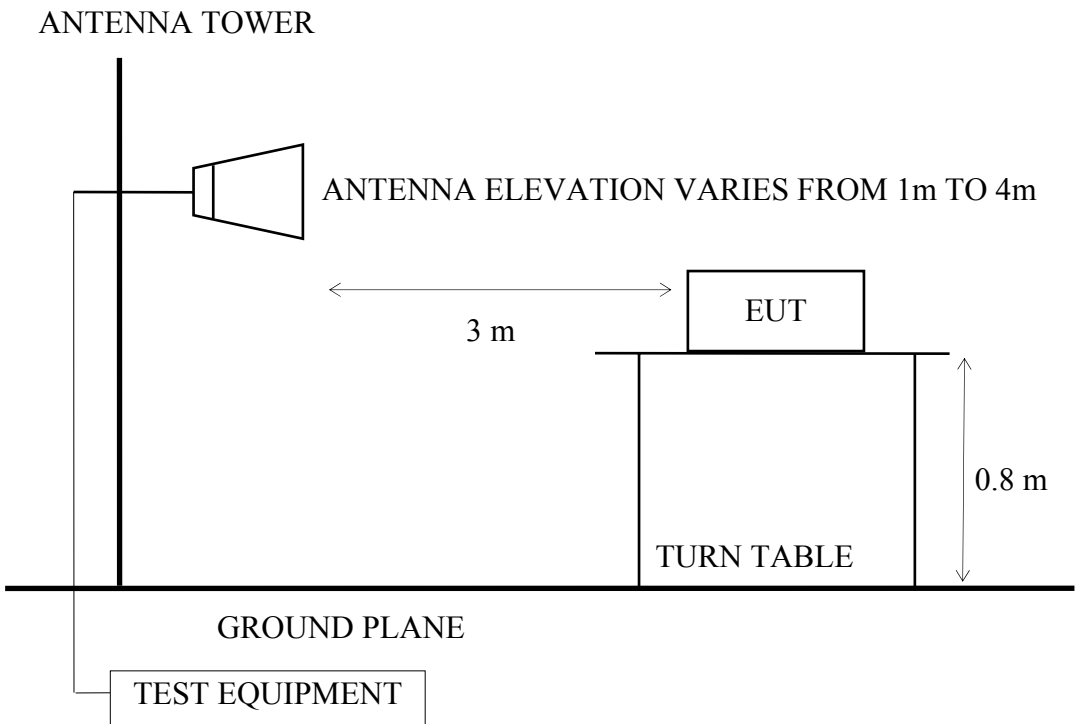

3.3. Radiated Emission Limits (§15.209)

FREQUENCY MHz	DISTANCE Meters	FIELD STRENGTHS LIMITS	
		$\mu\text{V/m}$	$\text{dB}\mu\text{V/m}$
30 ~ 88	3	100	40.0
88 ~ 216	3	150	43.5
216 ~ 960	3	200	46.0
Above 960	3	500	54.0
Above 1000	3	74.0 $\text{dB}\mu\text{V/m}$ (Peak) 54.0 $\text{dB}\mu\text{V/m}$ (Average)	

- Remark :
- (1) Emission level ($\text{dB}\mu\text{V/m}$) = 20 log Emission level ($\mu\text{V/m}$)
 - (2) The tighter limit applies at the edge between two frequency bands.
 - (3) Distance refers to the distance in meters between the measuring instrument antenna and the closed point of any part of the device or system.
 - (4) The limits in this table are based on CFR 47 Part 15.205(a)(b) and Part 15.209 (a).
 - (5) The over 1GHz limit, FCC limit is used based on CFR 47 Part 15.35 (b) and Part 15.205(b) & Part 15.209(e) and Part 15.207(c).

3.4. Operating Condition of EUT

- 3.4.1. Set up the EUT (Ceiling Fan Remote Controller) and simulator as shown on 3.2.1.
- 3.4.2. To turn on the power of all equipments.
- 3.4.3. The EUT set to continuously transmit signals at 2402MHz, 2440MHz and 2480MHz during all test time.

3.5. Test Procedure

The EUT and its simulators were placed on a turn table which was 0.8 meter above the ground. The turn table rotated 360 degrees to determine the position of the maximum emission level. EUT was set 3 meters away from the receiving antenna which was mounted on a antenna tower. The antenna moved up and down between 1 to 4 meters to find out the maximum emission level. Broadband antenna such as calibrated biconical and log-periodical antenna or horn antenna were used as a receiving antenna. Both horizontal and vertical polarization of the antenna were set on measurement. In order to find the maximum emission, all of the interface cables were manipulated according to ANSI C63.4-2003 regulation.

The bandwidth of the R&S Test Receiver was set at 120kHz. (For 30MHz to 1000MHz)

The resolution bandwidth and video bandwidth of test spectrum analyzer is 1MHz for peak detection (PK) at frequency above 1GHz.

The resolution bandwidth of test spectrum analyzer is 1MHz and the video bandwidth is 10Hz for average detection (AV) at frequency above 1GHz.

The frequency range from 30MHz to 25GHz (Up to 10th harmonics from fundamental frequency) was checked. 30MHz to 1000MHz was measured with Quasi-Peak detector.

Pursuant to ANSI C63.4 8.3.1.2, when peak value complies with the average limit, we didn't perform measurement in average detector.

3.6. Test Results

PASSED.

(All emissions not reported for there is no emission be found.)

For Frequency Range 30MHz~1000MHz:

The radiation tests on three different axes (stand, lie and side), we assessed the value and we selected the worse radiation position “lie” for our measured results.

The EUT with following test modes was performed during this section testing and all the test results are listed in section 3.6.1.

EUT: Ceiling Fan Remote Controller

M/N: MR101F

Test Date: Aug. 09, 2013 Temperature: 21 Humidity: 39%

No.	Test Mode and Frequency		Reference Test Data No.	
			Horizontal	Vertical
1.	Transmitting	2402MHz (CH0)	# 11	# 12
2.		2440MHz (CH19)	# 11	# 12
3.		2480MHz (CH39)	# 11	# 12

* Above all final readings were measured with Quasi-Peak detector.

For Frequency above 1GHz:

No.	Test Mode and Frequency		Reference Test Data	
			Horizontal	Vertical
1.	Transmitting	2402MHz (CH0)	# 3 ^(Note 2)	# 4 ^(Note 2)
2.		2440MHz (CH19)	# 3 ^(Note 2)	# 4 ^(Note 2)
3.		2480MHz (CH39)	# 3 ^(Note 2)	# 4 ^(Note 2)

Note: 1. Above all final readings were measured with Peak detector.

2. For measurements above 2.68GHz-4GHz, the peak measured value complies with the average limit, it is unnecessary to perform an average measurement. (According to ANSI C63.4-2003 section 8.3.1.2)

3. The emissions (up to 25GHz) not reported are too low to be measured.

For Restricted Bands:

The EUT was tested in restricted bands and all the test results are listed in section 3.6.2. (The restricted bands defined in part 15.205(a))

No	Test Mode and Frequency		Reference Test Data No.	
			Horizontal	Vertical
1.	Transmitting	2402MHz (CH0)	# 1, 2	# 3, 4
2.		2480MHz (CH39)	# 5, 6	# 7, 8

3.6.1. Frequency Range 30-1000MHz

Transmit, Frequency: 2402MHz

Site no. : Audix NO.1 3m Chamber Data no. : 11
 Dis. / Ant. : 3m VBA6106A/UHALP9108A Ant. pol. : HORIZONTAL
 Limit : FCC PART 15C
 Env. / Ins. : 21°C/39% N9030A(140) Engineer : Johnny_hsueh
 EUT : MR101F
 Power Rating : 120Vac/60Hz
 Test Mode : Tx 2402MHz

	Freq. (MHz)	Ant. Factor (dB/m)	Cable Loss (dB)	Reading (dBµV)	Emission Level (dBµV/m)	Limits (dBµV/m)	Margin (dB)	Remark
1	30.00	24.86	1.10	-0.11	25.85	40.00	14.15	Peak
2	148.49	20.27	2.50	10.77	33.54	48.50	9.96	Peak
3	299.66	26.77	3.90	1.92	32.59	46.00	13.41	Peak
4	360.77	16.24	4.43	14.59	35.26	46.00	10.74	Peak
5	664.38	22.61	6.31	6.62	35.54	46.00	10.46	Peak

Remarks: 1. Emission Level= Antenna Factor + Cable Loss + Reading.
 2. The emission levels that are 20dB below the official limit are not reported.

Site no. : Audix NO.1 3m Chamber Data no. : 12
 Dis. / Ant. : 3m VBA6106A/UHALP9108A Ant. pol. : VERTICAL
 Limit : FCC PART 15C
 Env. / Ins. : 21°C/39% N9030A(140) Engineer : Johnny_hsueh
 EUT : MR101F
 Power Rating : 120Vac/60Hz
 Test Mode : Tx 2402MHz

	Freq. (MHz)	Ant. Factor (dB/m)	Cable Loss (dB)	Reading (dBµV)	Emission Level (dBµV/m)	Limits (dBµV/m)	Margin (dB)	Remark
1	30.00	24.86	1.10	-0.43	25.53	40.00	14.47	Peak
2	148.34	20.58	2.60	12.20	35.38	48.50	8.12	Peak
3	294.81	26.43	3.99	1.44	31.86	46.00	14.14	Peak
4	869.05	25.77	7.20	1.82	34.79	46.00	11.21	Peak

Remarks: 1. Emission Level= Antenna Factor + Cable Loss + Reading.
 2. The emission levels that are 20dB below the official limit are not reported.

Transmit, Frequency: 2440MHz

Site no. : Audix NO.1 3m Chamber Data no. : 11
 Dis. / Ant. : 3m VBA6106A/UHALP9108A Ant. pol. : HORIZONTAL
 Limit : FCC PART 15C
 Env. / Ins. : 21°C/39% N9030A(140) Engineer : Johnny_hsueh
 EUT : MR101F
 Power Rating : 120Vac/60Hz
 Test Mode : Tx 2441MHz

	Freq. (MHz)	Ant. Factor (dB/m)	Cable Loss (dB)	Reading (dB μ V)	Emission Level (dB μ V/m)	Limits (dB μ V/m)	Margin (dB)	Remark
1	30.97	24.81	1.10	0.52	26.43	40.00	13.57	Peak
2	166.77	20.96	2.70	3.47	27.13	43.50	16.37	Peak
3	299.66	26.77	3.90	1.24	31.91	46.00	14.09	Peak
4	496.57	18.70	6.40	6.31	31.41	46.00	14.59	Peak
5	910.76	25.03	7.40	7.81	40.24	46.00	5.76	Peak

Remarks: 1. Emission Level= Antenna Factor + Cable Loss + Reading.
 2. The emission levels that are 20dB below the official limit are not reported.

Site no. : Audix NO.1 3m Chamber Data no. : 12
 Dis. / Ant. : 3m VBA6106A/UHALP9108A Ant. pol. : VERTICAL
 Limit : FCC PART 15C
 Env. / Ins. : 21°C/39% N9030A(140) Engineer : Johnny_hsueh
 EUT : MR101F
 Power Rating : 120Vac/60Hz
 Test Mode : Tx 2441MHz

	Freq. (MHz)	Ant. Factor (dB/m)	Cable Loss (dB)	Reading (dB μ V)	Emission Level (dB μ V/m)	Limits (dB μ V/m)	Margin (dB)	Remark
1	30.00	24.86	1.10	0.29	26.25	40.00	13.75	Peak
2	77.53	13.22	1.80	13.73	28.75	40.00	11.25	Peak
3	127.97	19.62	2.40	12.35	34.37	43.50	9.13	Peak
4	151.25	20.65	2.60	13.93	37.18	43.50	6.32	Peak
5	297.72	26.68	3.98	0.84	31.50	46.00	14.50	Peak
6	672.14	22.85	6.40	5.37	34.62	46.00	11.38	Peak

Remarks: 1. Emission Level= Antenna Factor + Cable Loss + Reading.
 2. The emission levels that are 20dB below the official limit are not reported.

Transmit, Frequency: 2480MHz

Site no. : Audix NO.1 3m Chamber
 Dis. / Ant. : 3m VBA6106A/UHALP9108A
 Limit : FCC PART 15C
 Env. / Ins. : 21°C/39% N9030A(140)
 EUT : MR101F
 Power Rating : 120Vac/60Hz
 Test Mode : Tx 2480MHz

Data no. : 11
 Ant. pol. : HORIZONTAL
 Engineer : Johnny_hsueh

	Freq. (MHz)	Ant. Factor (dB/m)	Cable Loss (dB)	Reading (dBµV)	Emission Level (dBµV/m)	Limits (dBµV/m)	Margin (dB)	Remark
1	30.00	24.86	1.10	0.66	26.62	40.00	13.38	Peak
2	115.36	18.69	2.30	6.34	27.33	43.50	16.17	Peak
3	293.84	26.33	3.96	1.58	31.87	46.00	14.13	Peak
4	515.97	19.98	6.80	3.97	30.75	46.00	15.25	Peak
5	861.29	26.09	7.20	2.12	35.41	46.00	10.59	Peak

Remarks: 1. Emission Level= Antenna Factor + Cable Loss + Reading.
 2. The emission levels that are 20dB below the official limit are not reported.

Site no. : Audix NO.1 3m Chamber
 Dis. / Ant. : 3m VBA6106A/UHALP9108A
 Limit : FCC PART 15C
 Env. / Ins. : 21°C/39% N9030A(140)
 EUT : MR101F
 Power Rating : 120Vac/60Hz
 Test Mode : Tx 2480MHz

Data no. : 12
 Ant. pol. : VERTICAL
 Engineer : Johnny_hsueh

	Freq. (MHz)	Ant. Factor (dB/m)	Cable Loss (dB)	Reading (dBµV)	Emission Level (dBµV/m)	Limits (dBµV/m)	Margin (dB)	Remark
1	31.94	24.26	1.10	0.66	26.02	40.00	13.98	Peak
2	172.59	21.04	2.80	10.59	34.43	43.50	9.07	Peak
3	294.81	26.43	3.99	1.74	32.16	46.00	13.84	Peak
4	369.50	16.93	4.60	14.78	36.31	46.00	9.69	Peak
5	600.36	21.31	6.30	11.28	38.89	46.00	7.11	Peak
6	861.29	26.09	7.20	2.58	35.87	46.00	10.13	Peak

Remarks: 1. Emission Level= Antenna Factor + Cable Loss + Reading.
 2. The emission levels that are 20dB below the official limit are not reported.

3.6.2. For Above 1GHz Frequency Range Measurement Results

Transmit, Frequency: 2402MHz

Site no. : Audix NO.1 3m Chamber
 Dis. / Ant. : 3m 3115(4927)
 Limit : FCC PART 15C(1G-PK)
 Env. / Ins. : 21°C/39% N9030A(140)
 EUT : MR101F
 Power Rating : 120Vac/60Hz
 Test Mode : Tx 2402MHz

Data no. : 3
 Ant. pol. : HORIZONTAL
 Engineer : Johnny_hsueh

	Freq. (MHz)	Ant. Factor (dB/m)	Cable Loss (dB)	Reading (dBµV)	Emission Level (dBµV/m)	Limits (dBµV/m)	Margin (dB)	Remark
1	3644.92	31.70	8.00	12.22	51.92	74.00	22.08	Peak

Remarks: 1. Emission Level= Antenna Factor + Cable Loss + Reading.
 2. The emission levels that are 20dB below the official limit are not reported.

Site no. : Audix NO.1 3m Chamber
 Dis. / Ant. : 3m 3115(4927)
 Limit : FCC PART 15C(1G-PK)
 Env. / Ins. : 21°C/39% N9030A(140)
 EUT : MR101F
 Power Rating : 120Vac/60Hz
 Test Mode : Tx 2402MHz

Data no. : 4
 Ant. pol. : VERTICAL
 Engineer : Johnny_hsueh

	Freq. (MHz)	Ant. Factor (dB/m)	Cable Loss (dB)	Reading (dBµV)	Emission Level (dBµV/m)	Limits (dBµV/m)	Margin (dB)	Remark
1	3644.92	31.70	8.00	13.77	53.47	74.00	20.53	Peak

Remarks: 1. Emission Level= Antenna Factor + Cable Loss + Reading.
 2. The emission levels that are 20dB below the official limit are not reported.

Transmit, Frequency: 2440MHz

Site no.	: Audix NO.1 3m Chamber	Data no.	: 3
Dis. / Ant.	: 3m 3115(4927)	Ant. pol.	: HORIZONTAL
Limit	: FCC PART 15C(1G-PK)	Engineer	: Johnny_hsueh
Env. / Ins.	: 21*C/39% N9030A(140)		
EUT	: MR101F		
Power Rating	: 120Vac/60Hz		
Test Mode	: Tx 2441MHz		

	Freq. (MHz)	Ant. Factor (dB/m)	Cable Loss (dB)	Reading (dB μV)	Emission Level (dB μV/m)	Limits (dB μV/m)	Margin (dB)	Remark
1	9646.24	31.70	8.00	11.38	51.08	74.00	22.92	Peak

Remarks: 1. Emission Level= Antenna Factor + Cable Loss + Reading.
 2. The emission levels that are 20dB below the official limit are not reported.

Site no.	: Audix NO.1 3m Chamber	Data no.	: 4
Dis. / Ant.	: 3m 3115(4927)	Ant. pol.	: VERTICAL
Limit	: FCC PART 15C(1G-PK)	Engineer	: Johnny_hsueh
Env. / Ins.	: 21*C/39% N9030A(140)		
EUT	: MR101F		
Power Rating	: 120Vac/60Hz		
Test Mode	: Tx 2441MHz		

	Freq. (MHz)	Ant. Factor (dB/m)	Cable Loss (dB)	Reading (dB μV)	Emission Level (dB μV/m)	Limits (dB μV/m)	Margin (dB)	Remark
1	9646.24	31.70	8.00	13.86	53.56	74.00	20.44	Peak

Remarks: 1. Emission Level= Antenna Factor + Cable Loss + Reading.
 2. The emission levels that are 20dB below the official limit are not reported.

Transmit, Frequency: 2480MHz

Site no. : Audix NO.1 3m Chamber
 Dis. / Ant. : 3m 3115(4927)
 Limit : FCC PART 15C(1G-PK)
 Env. / Ins. : 21°C/39% N9030A(140)
 EUT : MR101F
 Power Rating : 120Vac/60Hz
 Test Mode : Tx 2480MHz

Data no. : 3
 Ant. pol. : HORIZONTAL
 Engineer : Johnny_hsueh

	Freq. (MHz)	Ant. Factor (dB/m)	Cable Loss (dB)	Reading (dB μV)	Emission Level (dB μV/m)	Limits (dB μV/m)	Margin (dB)	Remark
1	3646.24	31.70	8.00	12.18	51.88	74.00	22.12	Peak

Remarks: 1. Emission Level= Antenna Factor + Cable Loss + Reading.
 2. The emission levels that are 20dB below the official limit are not reported.

Site no. : Audix NO.1 3m Chamber
 Dis. / Ant. : 3m 3115(4927)
 Limit : FCC PART 15C(1G-PK)
 Env. / Ins. : 21°C/39% N9030A(140)
 EUT : MR101F
 Power Rating : 120Vac/60Hz
 Test Mode : Tx 2480MHz

Data no. : 4
 Ant. pol. : VERTICAL
 Engineer : Johnny_hsueh

	Freq. (MHz)	Ant. Factor (dB/m)	Cable Loss (dB)	Reading (dB μV)	Emission Level (dB μV/m)	Limits (dB μV/m)	Margin (dB)	Remark
1	3646.24	31.70	8.00	14.17	53.87	74.00	20.13	Peak

Remarks: 1. Emission Level= Antenna Factor + Cable Loss + Reading.
 2. The emission levels that are 20dB below the official limit are not reported.

3.6.3. Restricted Bands Measurement Results

Date of Test : Aug. 09, 2013 Temperature : 21

EUT : Ceiling Fan Remote Controller Humidity : 39%

Test Mode : Transmitting Mode, Frequency: 2402MHz (CH0)

Data: 1 File: C:\Documents and Settings\rf_room\桌面\C1M1307126 RF0808\C1M1307126 BLE Date: 2013-08-09

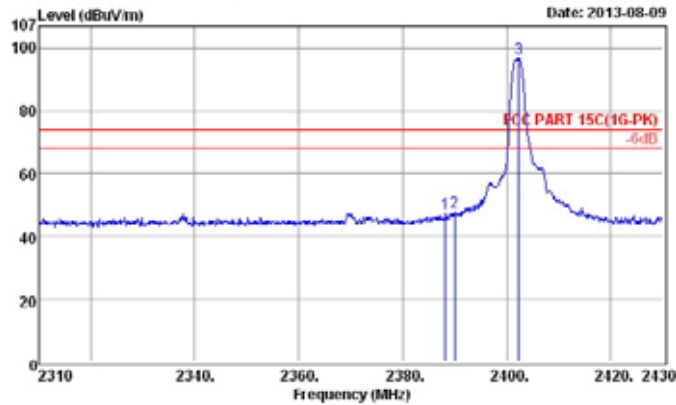

Site no. : Audix NO.1 3m Chamber Data no. : 1
 Dis. / Ant. : 3m 3115(4927) Ant. pol. : HORIZONTAL
 Limit : FCC PART 15C(1G-PK)
 Env. / Ins. : 21°C/38% N9030A(140) Engineer : Johnny_hsueh
 EUT : WR101F
 Power Rating : 120Vac/60Hz
 Test Mode : Tx 2402MHz

	Freq. (MHz)	Ant. Factor (dB/m)	Cable Loss (dB)	Reading (dBμV)	Emission Level (dBμV/m)	Limit (dBμV/m)	Margin (dB)	Remark
1	2388.24	28.47	8.34	12.44	47.25	74.00	26.75	Peak
2	2390.04	28.47	8.34	19.09	47.04	74.00	26.16	Peak
3	2402.28	28.47	8.38	61.88	88.78	74.00	-22.78	Peak

Remarks: 1. Emission Level= Antenna Factor + Cable Loss + Reading.
 2. The emission levels that are 20dB below the official limit are not reported.

Data: 2 File: C:\Documents and Settings\rf_room\桌面\C1M1307126 RF0808\C1M1307126 BLE Date: 2013-08-09

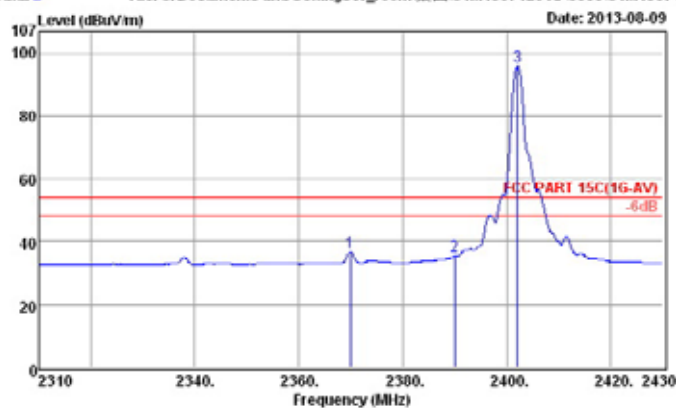

Site no. : Audix NO.1 3m Chamber Data no. : 2
 Dis. / Ant. : 3m 3115(4927) Ant. pol. : HORIZONTAL
 Limit : FCC PART 15C(1G-AV)
 Env. / Ins. : 21°C/38% N9030A(140) Engineer : Johnny_hsueh
 EUT : WR101F
 Power Rating : 120Vac/60Hz
 Test Mode : Tx 2402MHz

	Freq. (MHz)	Ant. Factor (dB/m)	Cable Loss (dB)	Reading (dBμV)	Emission Level (dBμV/m)	Limit (dBμV/m)	Margin (dB)	Remark
1	2370.00	28.43	8.31	1.99	36.73	54.00	17.27	Average
2	2380.04	28.47	8.34	0.42	35.23	54.00	18.77	Average
3	2402.04	28.47	8.36	61.11	35.94	54.00	-41.94	Average

Remarks: 1. Emission Level= Antenna Factor + Cable Loss + Reading.
 2. The emission levels that are 20dB below the official limit are not reported.

Date of Test : Aug. 09, 2013 Temperature : 21

EUT : Ceiling Fan Remote Controller Humidity : 39%

Test Mode : Transmitting Mode, Frequency: 2402MHz (CH0)

Data: 3 File: C:\Documents and Settings\rf_room\桌面\C1M1307126 RF-0808\C1M1307126 BLE Date: 2013-08-09

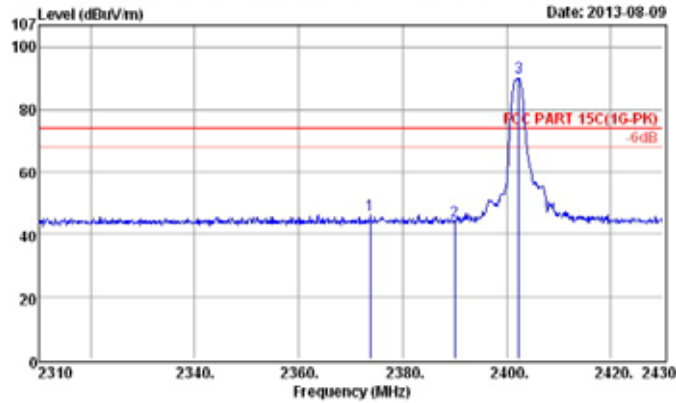

Site no. : Audix NO.1 3m Chamber Data no. : 3
 Dis. / Ant. : 3m 3115(4927) Ant. pol. : VERTICAL
 Limit : FCC PART 15C(1G-PK)
 Env. / Ins. : 21°C/39% N9030A(140) Engineer : Johnny_hsueh
 EUT : WR101F
 Power Rating : 120Vac/60Hz
 Test Mode : Tx 2402MHz

Peak	Freq. (MHz)	Ant. Factor (dB/m)	Cable Loss (dB)	Reading (dB μV)	Emission Level (dB μV/m)	Limit (dB μV/m)	Margin (dB)	Remark
1	2378.72	29.49	8.32	11.49	46.10	74.00	27.82	Peak
2	2380.04	29.47	8.34	8.40	44.21	74.00	28.79	Peak
3	2402.28	29.47	8.38	55.29	90.12	74.00	-16.12	Peak

Remarks: 1. Emission Level= Antenna Factor + Cable Loss + Reading.
 2. The emission levels that are 20dB below the official limit are not reported.

Data: 4 File: C:\Documents and Settings\rf_room\桌面\C1M1307126 RF-0808\C1M1307126 BLE Date: 2013-08-09

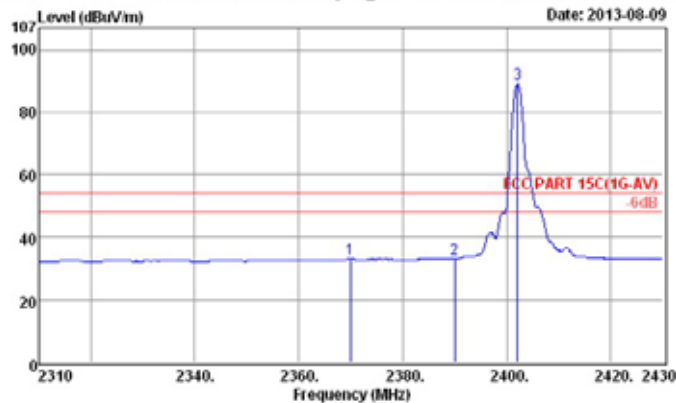

Site no. : Audix NO.1 3m Chamber Data no. : 4
 Dis. / Ant. : 3m 3115(4927) Ant. pol. : VERTICAL
 Limit : FCC PART 15C(1G-AV)
 Env. / Ins. : 21°C/39% N9030A(140) Engineer : Johnny_hsueh
 EUT : WR101F
 Power Rating : 120Vac/60Hz
 Test Mode : Tx 2402MHz

Peak	Freq. (MHz)	Ant. Factor (dB/m)	Cable Loss (dB)	Reading (dB μV)	Emission Level (dB μV/m)	Limit (dB μV/m)	Margin (dB)	Remark
1	2378.00	29.49	8.31	-1.62	39.12	54.00	20.00	Average
2	2380.04	29.47	8.34	-1.86	38.15	54.00	20.85	Average
3	2402.04	29.47	8.38	54.15	98.98	54.00	-34.98	Average

Remarks: 1. Emission Level= Antenna Factor + Cable Loss + Reading.
 2. The emission levels that are 20dB below the official limit are not reported.

Date of Test : Aug. 09, 2013 Temperature : 21

EUT : Ceiling Fan Remote Controller Humidity : 39%

Test Mode : Transmitting Mode, Frequency: 2480MHz (CH39)

Data: 5 File: C:\Documents and Settings\rf_room\桌面\C1M1307126 RF\0808\C1M1307126 BLE\ Date: 2013-08-09

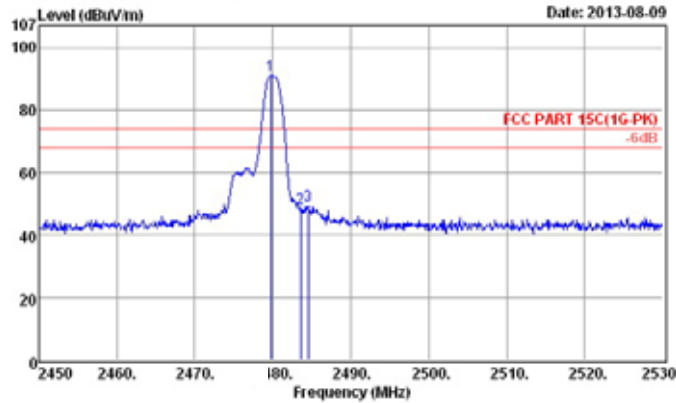

Site no. : Audix NO.1 3m Chamber Data no. : 5
 Dis. / Ant. : 3m 3115(4827) Ant. pol. : HORIZONTAL
 Limit : FCC PART 15C(1G-PK)
 Env. / Ins. : 21°C/38% N9030A(140) Engineer : Johnny_hsuoh
 EUT : MR101F
 Power Rating : 120Vac/60Hz
 Test Mode : Tx 2480MHz

Peak	Freq. (MHz)	Ant. Factor (dB/m)	Cable Loss (dB)	Reading (dBµV)	Emission Level (dBµV/m)	Limit (dBµV/m)	Margin (dB)	Remark
1	2479.78	28.88	8.44	58.00	91.10	74.00	-17.10	Peak
2	2488.80	28.88	8.45	18.44	48.55	74.00	25.45	Peak
3	2484.86	28.88	8.46	14.37	48.48	74.00	24.52	Peak

Remarks: 1. Emission Level= Antenna Factor + Cable Loss + Reading.
 2. The emission levels that are 20dB below the official limit are not reported.

Data: 6 File: C:\Documents and Settings\rf_room\桌面\C1M1307126 RF\0808\C1M1307126 BLE\ Date: 2013-08-09

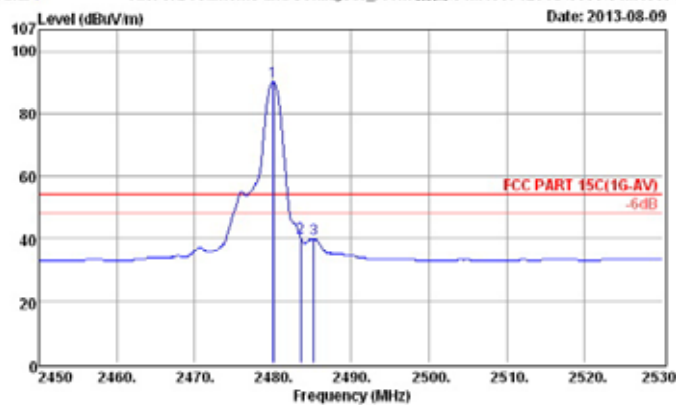

Site no. : Audix NO.1 3m Chamber Data no. : 6
 Dis. / Ant. : 3m 3115(4827) Ant. pol. : HORIZONTAL
 Limit : FCC PART 15C(1G-AV)
 Env. / Ins. : 21°C/38% N9030A(140) Engineer : Johnny_hsuoh
 EUT : MR101F
 Power Rating : 120Vac/60Hz
 Test Mode : Tx 2480MHz

Peak	Freq. (MHz)	Ant. Factor (dB/m)	Cable Loss (dB)	Reading (dBµV)	Emission Level (dBµV/m)	Limit (dBµV/m)	Margin (dB)	Remark
1	2480.08	28.88	8.44	55.24	90.34	54.00	-36.34	Average
2	2483.80	28.88	8.45	5.15	40.28	54.00	13.74	Average
3	2485.20	28.88	8.45	4.75	39.88	54.00	14.14	Average

Remarks: 1. Emission Level= Antenna Factor + Cable Loss + Reading.
 2. The emission levels that are 20dB below the official limit are not reported.

Date of Test : Aug. 09, 2013 Temperature : 21

EUT : Ceiling Fan Remote Controller Humidity : 39%

Test Mode : Transmitting Mode, Frequency: 2480MHz (CH39)

Data: 7 File: C:\Documents and Settings\rf_room\桌面\C1M1307126 RF0808\C1M1307126 BLE Date: 2013-08-09

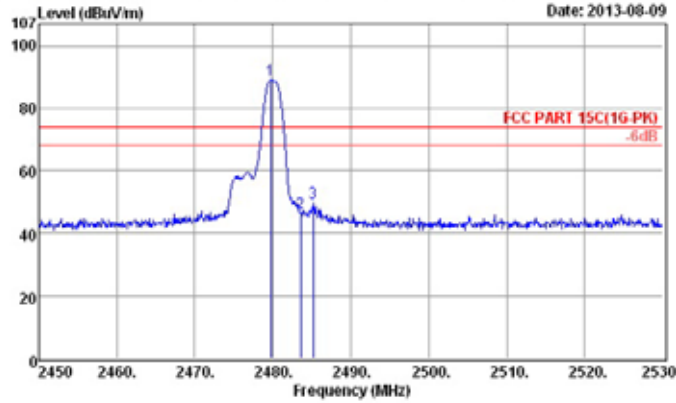

Site no. : Audix NO.1 3m Chamber Data no. : 7
 Dis. / Ant. : 3m 3115(4927) Ant. pol. : VERTICAL
 Limit : FCC PART 15C(1G-PK)
 Env. / Ins. : 21°C/38% N9030A(140) Engineer : Johnny_hsuoh
 EUT : WR101F
 Power Rating : 120Vac/60Hz
 Test Mode : Tx 2480MHz

Peak	Freq. (MHz)	Ant. Factor (dB/m)	Cable Loss (dB)	Reading (dBµV)	Emission Level (dBµV/m)	Limit (dBµV/m)	Margin (dB)	Remark
1	2479.76	28.66	6.44	54.86	89.80	74.00	-15.16	Peak
2	2483.80	28.66	6.45	11.53	46.70	74.00	27.30	Peak
3	2485.20	28.66	6.45	14.49	49.60	74.00	24.40	Peak

Remarks: 1. Emission Level= Antenna Factor + Cable Loss + Reading.
 2. The emission levels that are 20dB below the official limit are not reported.

Data: 8 File: C:\Documents and Settings\rf_room\桌面\C1M1307126 RF0808\C1M1307126 BLE Date: 2013-08-09

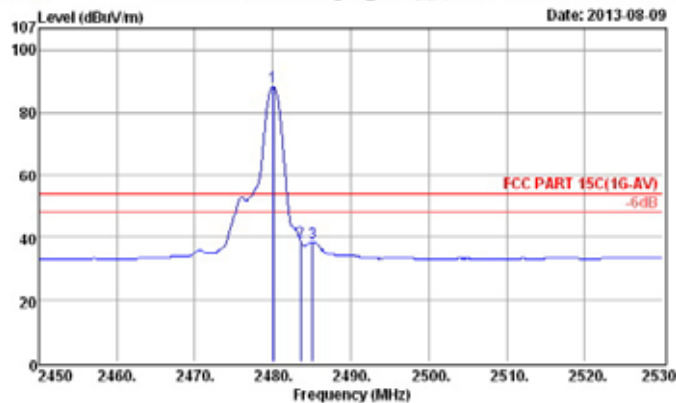

Site no. : Audix NO.1 3m Chamber Data no. : 8
 Dis. / Ant. : 3m 3115(4927) Ant. pol. : VERTICAL
 Limit : FCC PART 15C(1G-AV)
 Env. / Ins. : 21°C/38% N9030A(140) Engineer : Johnny_hsuoh
 EUT : WR101F
 Power Rating : 120Vac/60Hz
 Test Mode : Tx 2480MHz

Peak	Freq. (MHz)	Ant. Factor (dB/m)	Cable Loss (dB)	Reading (dBµV)	Emission Level (dBµV/m)	Limit (dBµV/m)	Margin (dB)	Remark
1	2480.00	28.66	6.44	58.23	88.83	54.00	-34.83	Average
2	2483.80	28.66	6.45	3.60	38.71	54.00	15.29	Average
3	2485.12	28.66	6.45	3.18	38.29	54.00	15.71	Average

Remarks: 1. Emission Level= Antenna Factor + Cable Loss + Reading.
 2. The emission levels that are 20dB below the official limit are not reported.

4. 6dB BANDWIDTH MEASUREMENT

4.1. Test Equipment

The following test equipment was used during the Emission Bandwidth measurement:

Item	Type	Manufacturer	Model No.	Serial No.	Last Cal.	Next Cal.
1.	Spectrum Analyzer	Agilent	N9030A-544	US51350140	Oct. 17, 12'	Oct. 16, 13'

4.2. Block Diagram of Test Setup

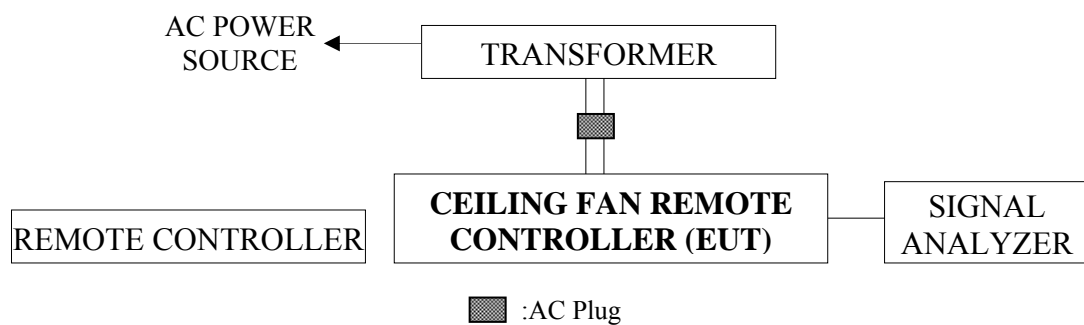

4.3. Specification Limits [§15.247(a)(2)]

The minimum 6dB bandwidth shall be at least 500kHz.

4.4. Operating Condition of EUT

- 4.4.1. Set up the EUT and simulator as shown on 4.2.
- 4.4.2. To turn on the power of all equipment.
- 4.4.3. The **EUT (Ceiling Fan Remote Controller)** was on transmitting function with the remote controller at work during all testing.

4.5. Test Procedure

The transmitter output was connected to the spectrum analyzer. The bandwidth of the fundamental frequency was measure by spectrum analyzer with 1.5% EBW, $VBW \geq 3 \times RBW$. The 6dB bandwidth is defined as the total spectrum the power of which is higher than peak power minus 6dB.

The measurement guideline was according to KDB 558074 D01 V03.

4.6. Test Results

PASSED. All the test results are attached in next pages.

Test Date : Aug. 05, 2013 Temperature : 21 Humidity : 39%

Mode	Channel	Frequency	6dB Bandwidth
1.	CH0	2402MHz	0.705MHz
2.	CH19	2440MHz	0.705MHz
3.	CH39	2480MHz	0.705MHz

[Limit: least 500kHz]

Frequency: 2402MHz

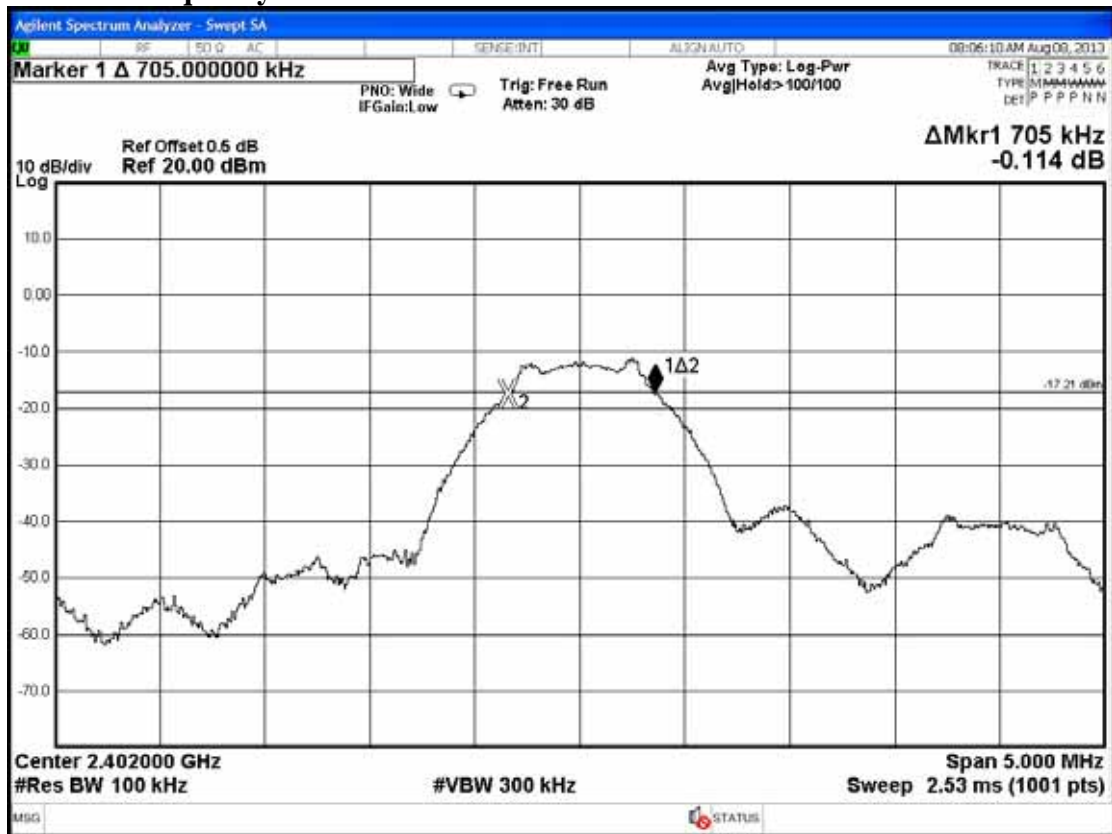

Frequency: 2440MHz

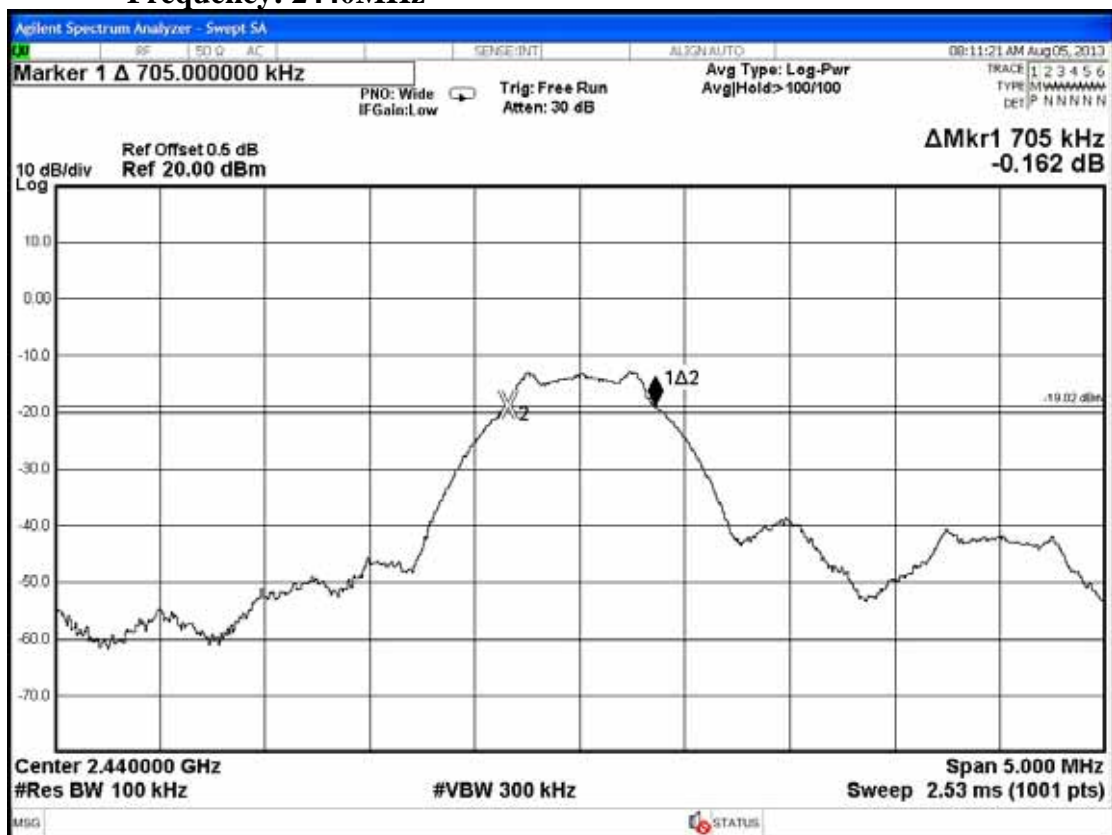

Frequency: 2480MHz

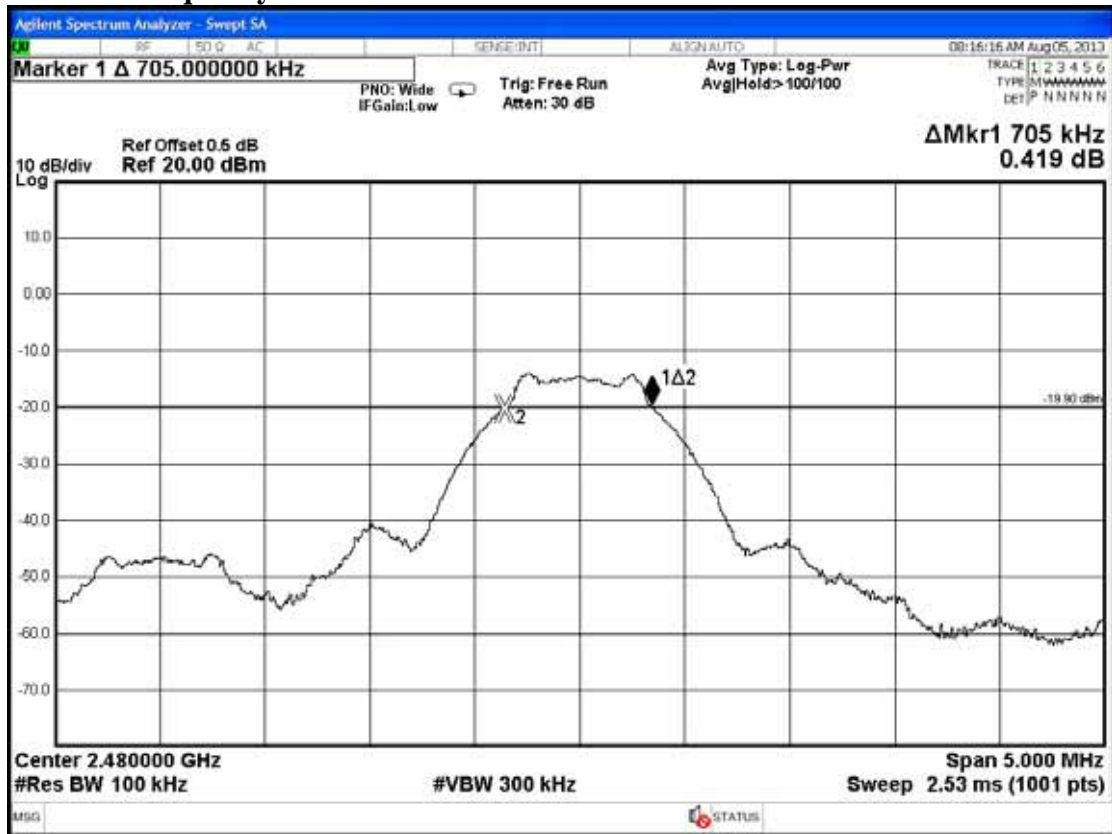

5. MAXIMUM PEAK OUTPUT POWER MEASUREMENT

5.1. Test Equipment

The following test equipment was used during the maximum peak output power measurement:

Item	Type	Manufacturer	Model No.	Serial No.	Last Cal.	Next Cal.
1.	Power Meter	Anritsu	ML2495A	1145008	Oct. 30, 12'	Oct. 29, 13'
2.	Power Sensor	Anritsu	MA2411B	1126096	Oct. 30, 12'	Oct. 29, 13'

5.2. Block Diagram of Test Setup

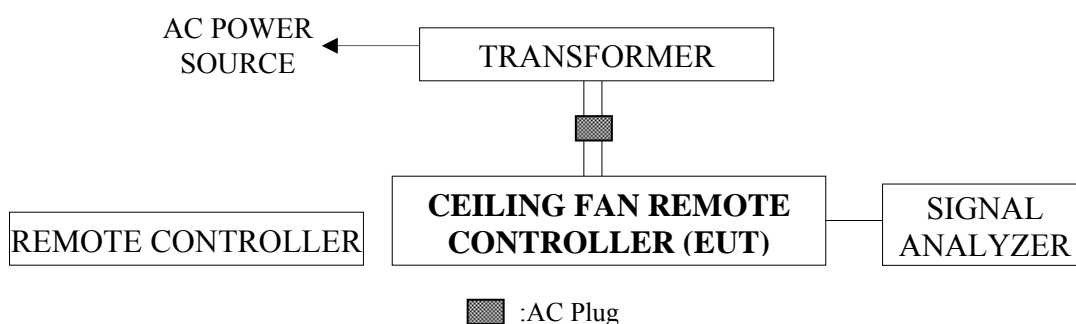

5.3. Specification Limits [§15.247(b)-(3)]

The Limits of maximum Peak Output Power for digital modulation in 2400-2483.5MHz is: 1Watt. (30dBm)

Pursuant to 15.247(b)-(4), the antenna gain has 0.3dB exceed 6 dBi, thus the conducted output power limit shall be reduced by the amount 0.3dB.

5.4. Operating Condition of EUT

- 5.4.1. Set up the EUT and simulator as shown on 5.2.
- 5.4.2. To turn on the power of all equipment.
- 5.4.3. The **EUT (Ceiling Fan Remote Controller)** was on transmitting function with the remote controller at work during all testing.

5.5. Test Procedure

The transmitter output was connected to the power sensor and record the reading of power meter.

The measurement guideline was according to KDB 558074 D01 V03.

5.6. Test Results

PASSED. All the test results are listed below.

Test Date : Aug. 05, 2013 Temperature : 21 Humidity : 39%

Mode	Channel	Frequency	Output Power(dBm)	
			Peak	Average
1.	CH0	2402MHz	-7.52	-9.26
2.	CH19	2440MHz	-9.11	-11.66
3.	CH39	2480MHz	-10.07	-13.66

[Limit: 1Watt. (30dBm)]

6. EMISSION LIMITATIONS MEASUREMENT

Pursuant to KDB558074 D01 V03 that emission levels below limits specified in 15.209 would not be required.

7. BAND EDGES MEASUREMENT

7.1. Test Equipment

The following test equipment was used during the band edges measurement:

Item	Type	Manufacturer	Model No.	Serial No.	Last Cal.	Next Cal.
1.	Spectrum Analyzer	Agilent	N9030A-544	US51350140	Oct. 17, 12'	Oct. 16, 13'

7.2. Block Diagram of Test Setup

The same as section.4.2.

7.3. Specification Limits [§15.247(c)]

The highest level should be at least 20 dB below reference level as measured in section 8.6.

7.4. Operating Condition of EUT

7.4.1. Set up the EUT and simulator as shown on 4.2.

7.4.2. To turn on the power of all equipment.

7.4.3. The **EUT (Ceiling Fan Remote Controller)** was on transmitting function with the remote controller at work during all testing.

7.5. Test Procedure

The transmitter output was connected to the spectrum analyzer. Set both RBW=100 kHz and VBW to 300kHz with suitable frequency span including 100kHz bandwidth from band edge.

The measurement guideline was according to KDB 558074 D01 V03.

7.6. Test Results

PASSED. All the test results are attached in next pages.

Test Date : Aug. 05, 2013 Temperature : 21 Humidity : 39%

Upper Band edge

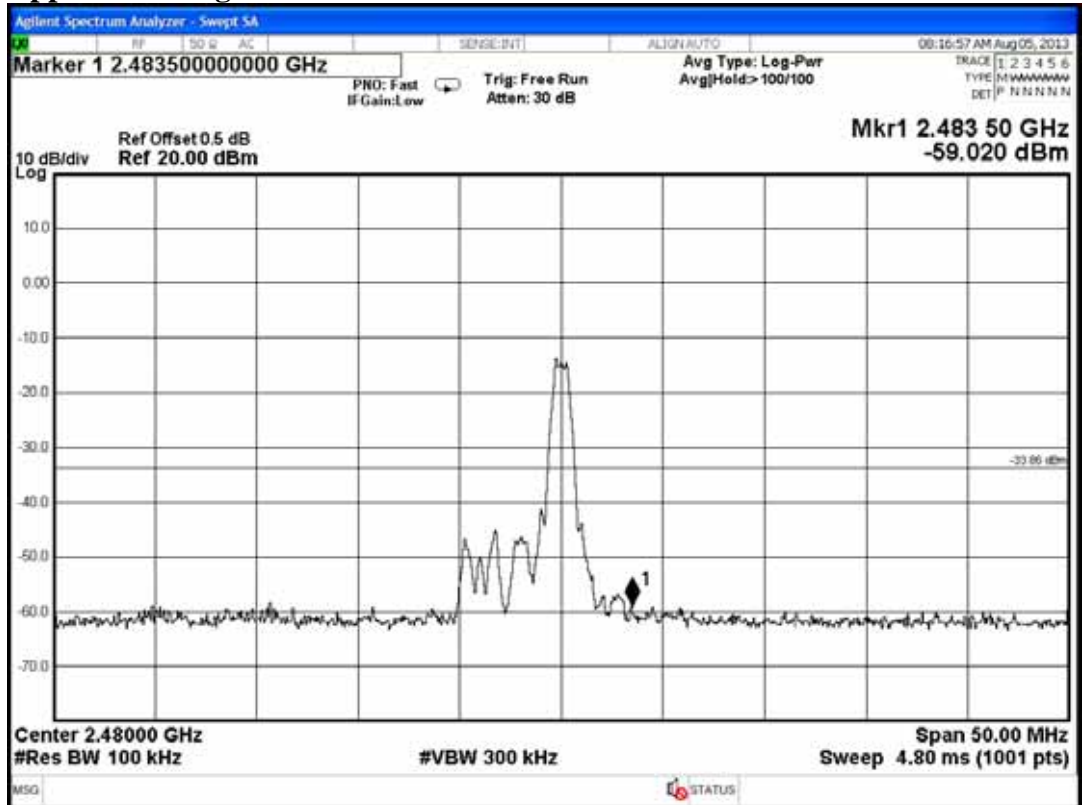

Below Band edge

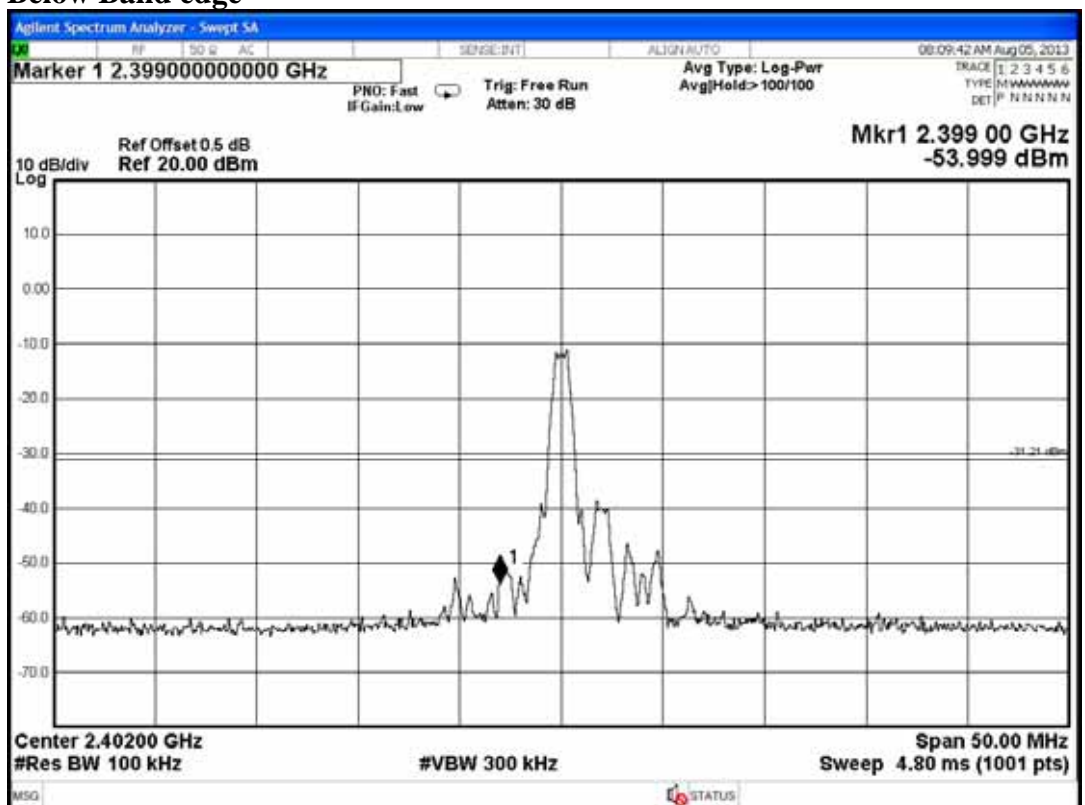

8. POWER SPECTRAL DENSITY MEASUREMENT

8.1. Test Equipment

The following test equipment was used during the power spectral density measurement:

Item	Type	Manufacturer	Model No.	Serial No.	Last Cal.	Next Cal.
1.	Spectrum Analyzer	Agilent	N9030A-544	US51350140	Oct. 17, 12'	Oct. 16, 13'

8.2. Block Diagram of Test Setup

The same as section.4.2.

8.3. Specification Limits [§15.247(d), RSS-210 §A8.2 (b)]

The peak power spectral density conducted from the intentional radiator to the antenna shall not be greater than 8dBm in any 3kHz band.

8.4. Operating Condition of EUT

8.4.1. Set up the EUT and simulator as shown on 4.2.

8.4.2. To turn on the power of all equipment.

8.4.3. The **EUT (Ceiling Fan Remote Controller)** was on transmitting function with the remote controller at work during all testing.

8.5. Test Procedure

The transmitter output was connected to the spectrum analyzer. The bandwidth of the fundamental frequency was measured with the spectrum analyzer using 100kHz RBW and ≥ 300 kHz VBW, set sweep time = Auto.

The measurement guideline was according to KDB 558074 D01v03 Peak PSD is used.

8.6. Test Results

PASSED. All the test results are attached in next pages.

Test Date : Aug. 05, 2013 Temperature : 21 Humidity : 39%

Mode	Channel	Frequency	Power Spectral Density (dBm)
1.	CH0	2402MHz	-11.053
2.	CH19	2440MHz	-12.726
3.	CH39	2480MHz	-13.843

[Limit: 4dBm]

Frequency: 2402MHz

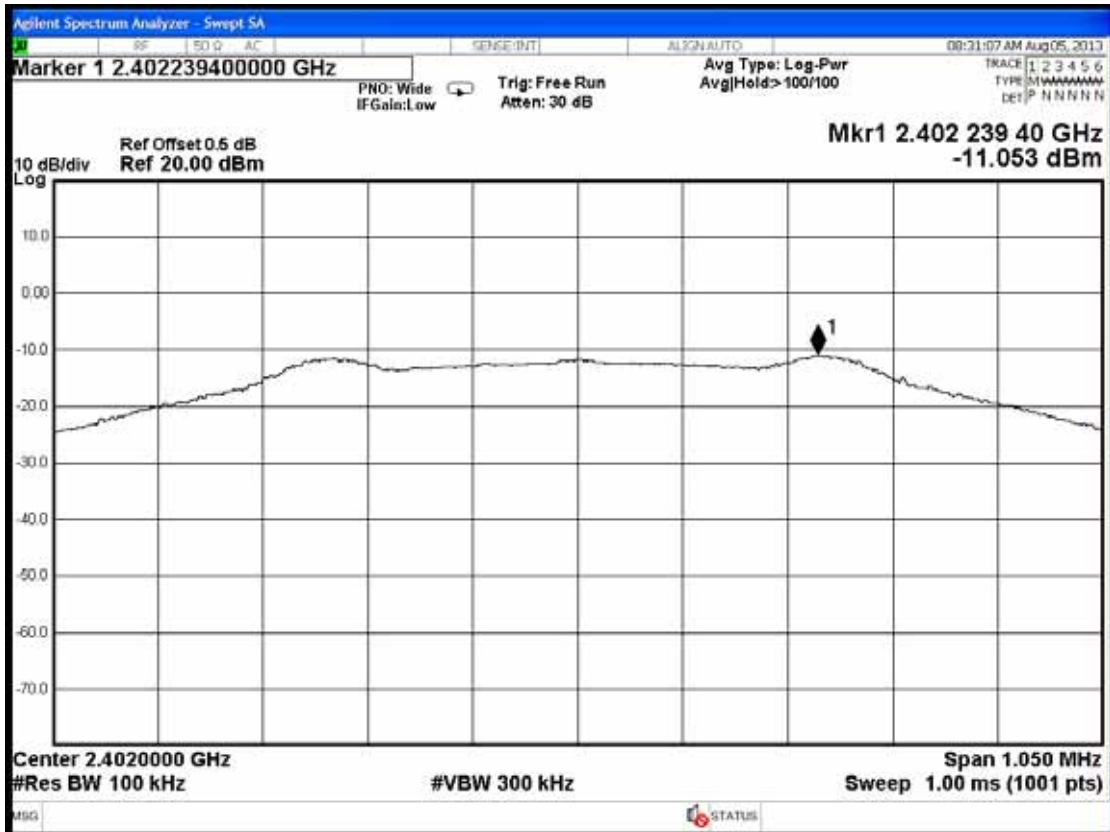

Frequency: 2440MHz

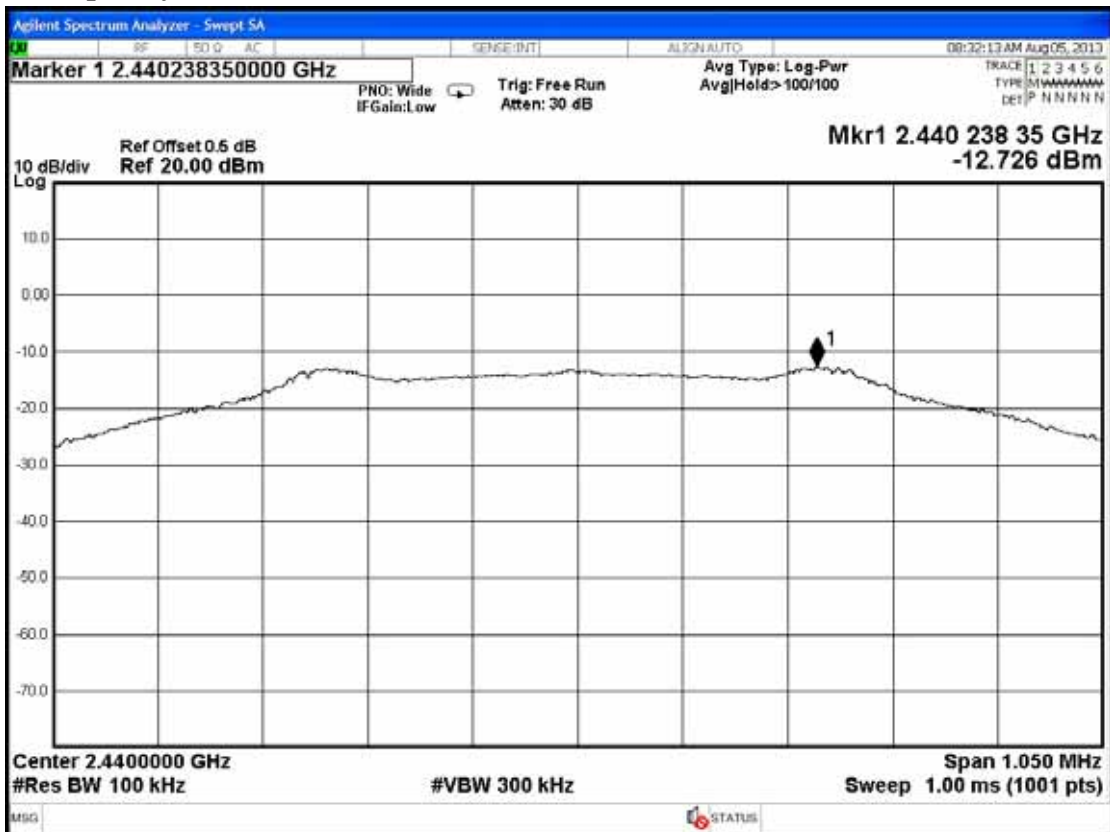

Frequency: 2480MHz

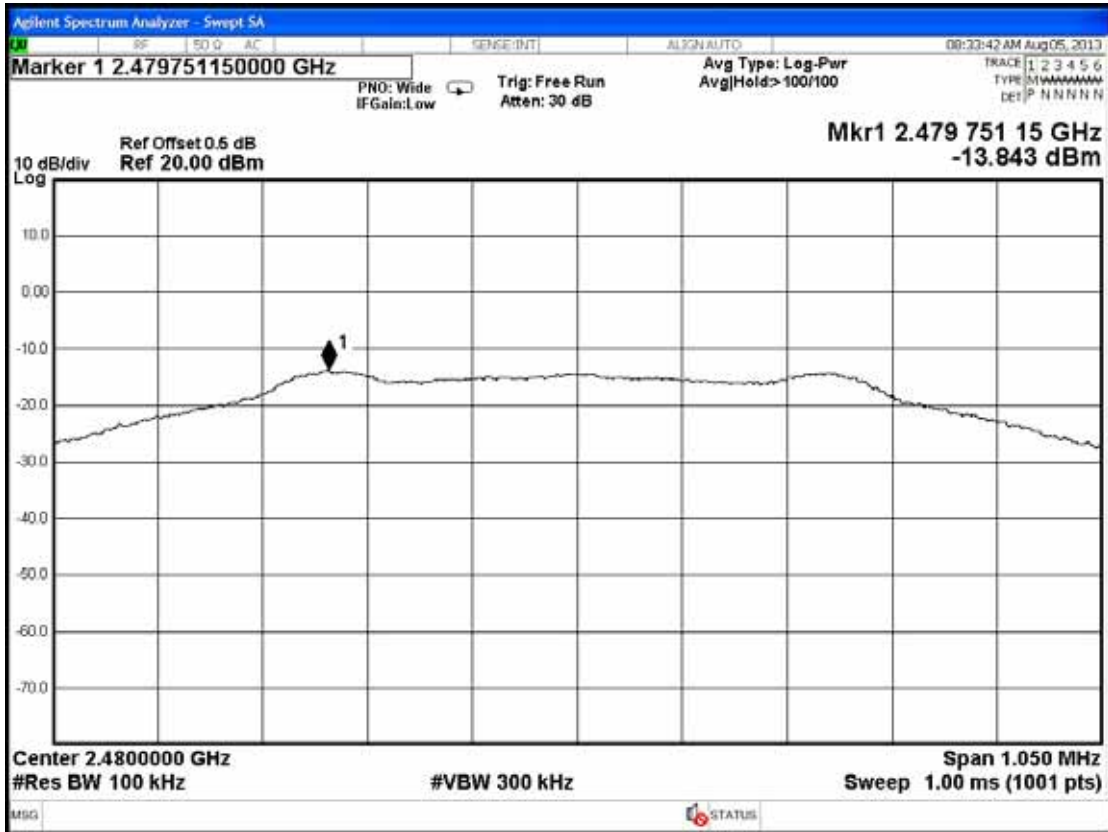

9. DEVIATION TO TEST SPECIFICATIONS

【NONE】

10. PHOTOGRAPHS

10.1. Photos of Conducted Emission Measurement



FRONT VIEW OF CONDUCTED MEASUREMENT



BACK VIEW OF CONDUCTED MEASUREMENT

10.2.Photos of Radiated Measurement at Semi-Anechoic Chamber

10.2.1.Frequency Below 1GHz



10.2.2. Frequency Above 1GHz



10.3.Photo of Section RF Conducted Measurement

