

Similarity Declaration

2021/4/6

TO WHOM IT MAY CONCERN,

We, **Continental Automotive GmbH** hereby declare that:

The new version of our product Tire Pressure Monitoring Sensor , model number TIS-10DL, uses the same schematic, layout and the only differences are the slight change of the LF coil pads size, battery hole enlargement and introduces another supplier for the RF antenna, using the same material and Ni-coating layer.

Please find below further explanations:

- Foot print update for LF coil – same location (updated dimensions for inner and outer length of the pads)

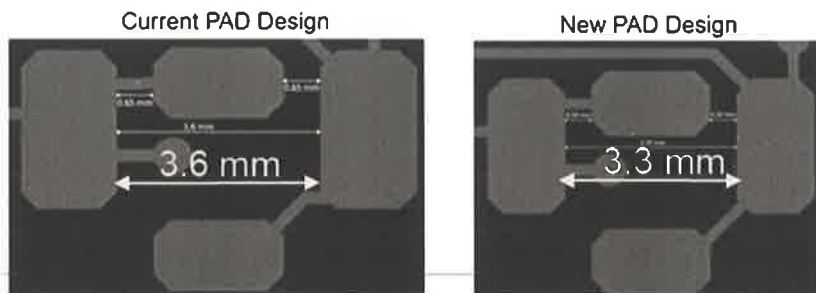

- Foot print update for battery hole;

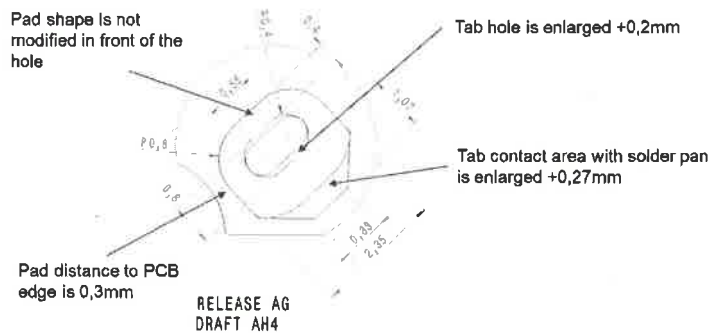

Sincerely yours,

Signature



Continental Automotive GmbH

Name: Anisoreac Alexandra

Designation: RF Homologation