

Tire Pressure Generation TIS-09DL

Wheel Unit

Type

ASK/FSK 433.92 MHz

1. SYSTEM OVERVIEW

The tire pressure monitoring system (referred as TG for Tire Guard) consists of the following units:

- Tire guard wheel unit type TIS-09DL which includes an integrated pressure, temperature and acceleration sensor and a RF transmitter.
- LF receiver unit which includes a LF receiver (not described in this document)

The TG monitors a vehicle's tire pressure whilst driving or stationary. An electronic unit (wheel unit) inside each tire, mounted to the valve stem, periodically measures the actual tire pressure. By means of RF communication, this pressure information is transmitted to the RF receiver.

2. TECHNICAL DESCRIPTION

Carrier frequency:	433.92 MHz
Number of channels:	1
Type of modulation:	Amplitude Shift Keying (ASK), Frequency Shift Keying (FSK)
Baud rate:	4096bps, 9600bps
Rated Output Power:	< 10mW
Antenna:	Internal
Voltage supply range:	2.1 up to 3.2V
Temperature range:	-40 up to +120°C

3. TYPICAL USAGE PATTERN

3.1 AVERAGE FACTOR CALCULATION (Standard 47 CFR Part 15C (periodic intentional transmitter))

Maximum transmitting duration in whatever 100ms windows: 19.73ms

$$\Rightarrow \text{Averaging factor} = 20 \times \log(19.73/100) = \underline{\underline{-14.1dB}}$$

Detail of the calculation:

Baudrate = 4096bps Tolerance Baudrate = 1%
→ Bit duration (max) = $1.01/4096 = 0,24658203125$

Frame Length = 10 bytes = 80 bits
→ Frame duration (max) = 19.73ms

Averaging Factor = $20 \times \log(\text{Frame duration} / 100\text{ms})$

Averaging Factor = -14.1dB

4. BLOCK DIAGRAM

The block diagram below shows the main electronic units of the wheel unit:

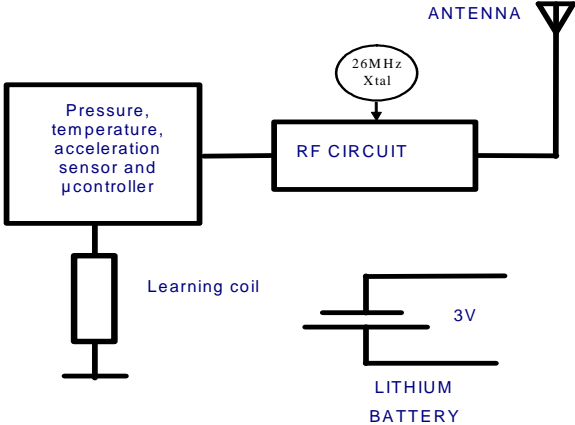

5. PICTURE





6. LABEL

6.1 USA

Continental
TIS-09DL
FCC ID: KR5TIS-09DL

This device complies with Part 15 of the FCC Rules. Operation is subject to the following two conditions: (1) this device may not cause harmful interference, and (2) this device must accept any interference received, including interference that may cause undesired operation.

Changes or modifications not expressly approved by the party responsible for compliance could void the user's authority to operate the equipment.

This equipment has been tested and found to comply with the limits for a Class B digital device, pursuant to part 15 of the FCC Rules. These limits are designed to provide reasonable protection against harmful interference in a residential installation. This equipment generates, uses and can radiate radio frequency energy and, if not installed and used in accordance with the instructions, may cause harmful interference to radio communications. However, there is no guarantee that interference will not occur in a particular installation. If this equipment does cause

harmful interference to radio or television reception, which can be determined by turning the equipment off and on, the user is encouraged to try to correct the interference by one or more of the following measures:

- Reorient or relocate the receiving antenna.
- Increase the separation between the equipment and receiver.
- Connect the equipment into an outlet on a circuit different from that to which the receiver is connected.
- Consult the dealer or an experienced radio/TV technician for help.

6.2 CANADA

Continental
Model: TIS-09DL
IC: 7812D-TIS09DL

This device complies with Industry Canada licence-exempt RSS standard(s). Operation is subject to the following two conditions: (1) this device may not cause interference, and (2) this device must accept any interference, including interference that may cause undesired operation of the device.

Le présent appareil est conforme aux CNR d'Industrie Canada applicables aux appareils radio exempts de licence. L'exploitation est autorisée aux deux conditions suivantes : (1) l'appareil ne doit pas produire de brouillage, et (2) l'utilisateur de l'appareil doit accepter tout brouillage radioélectrique subi, même si le brouillage est susceptible d'en compromettre le fonctionnement.