

Functional Description

of the

Continental

Immobilizer

REN_X52_20_IMSY-1

1. SYSTEM OVERVIEW

The immobilizer active antenna is suited to be used in combination with potentially two [X52] BCMs (one from Continental and one from CK) and 1 key module from Renault. System integration with competitor product is not assumed by Continental. Validation for additional combinations can be quoted upon request. The whole immobilizer function is accomplished by the mutual authentication between key and BCM while the active antenna is playing a role of charging transponder in key and data modulation (demodulation) in the communication path. The typical immobilizer system with active antenna can be referenced as below:

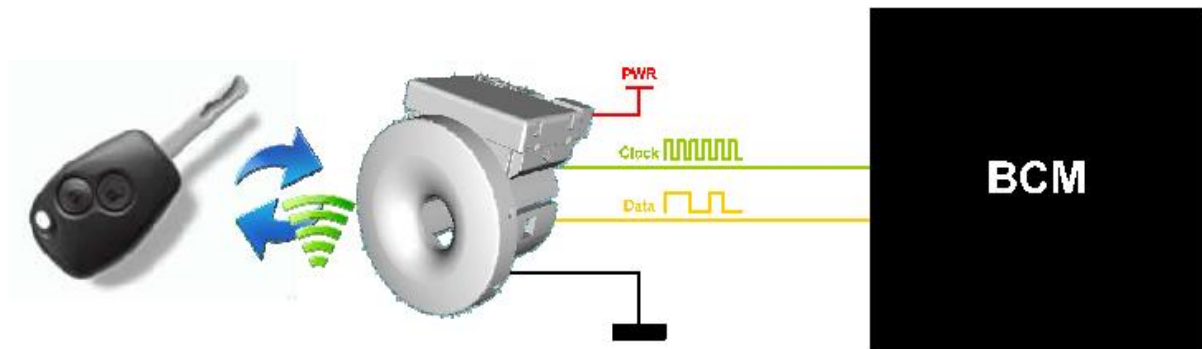

Magnetic field generation:

The active antenna contains base station for driven antenna coil which generates the LF field for charging transponder as well as carrying the modulated data.

Serial communication with BCM:

The active antenna is connected to BCM via synchronous serial link. LF communication data is converted to baseband signals by active antenna and transmitted in half-duplex mode between transponder and BCM on this interface.

The component of IMMO_ANT is to be installed on Vehicle lockset, the IMMO_ANT will be driven by BCM to generate magnetic field which can charge TxP and works as carrier of data transition. In Renault_X52_IMMO vehicle IMMO_ANT has no function of illumination.

The immobilizer circuit contains a voltage regulator, a serial interface, a base station IC and an LF antenna. The serial interface is the communication interface for the communication with the BCM. The BCM sends the data for initialization and

authentication to the Base station IC.

The active antenna contains the ABIC1 immobilizer base station IC, a ceramic resonator for clock generation, and a voltage regulator for stabilization of power input. It needs to be connected to the BCM for the communication function as well as to battery supply and ground.

The Base station IC generates the signals for the transmission to the transponder in the key and drives the antenna. After transmission the base station IC receives the answer from the transponder and sends the answer to the BCM. The software in the BCM controls the complete communication.

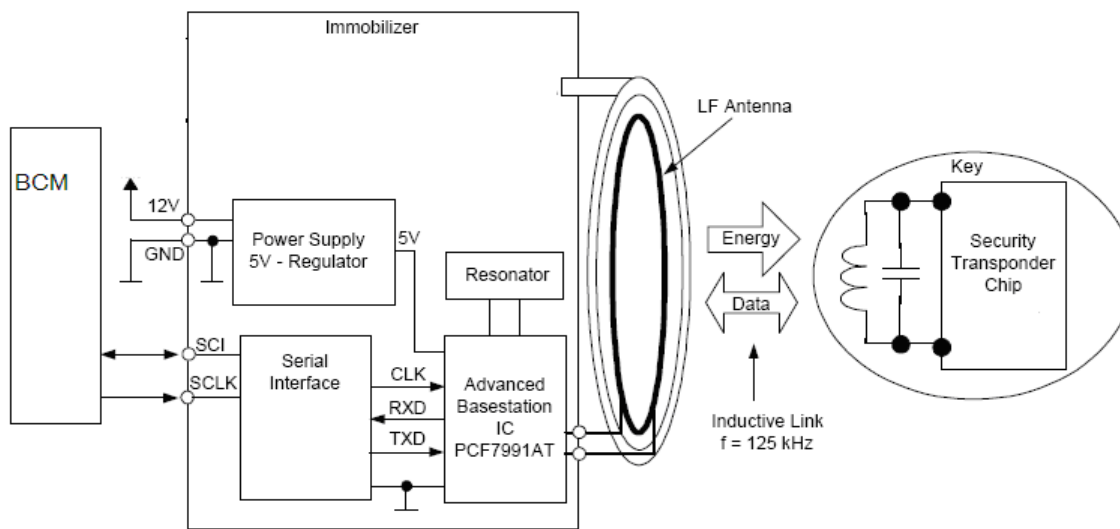

2. Product Characteristics

Service voltage	7V - 16V
Overvoltage protection (jump start)	24V (1 min)
Reserve voltage protection (overvoltage)	18V (1 hour)
Active current	<150 mA
Quiescent current	< 500uA
LF Antenna frequency	125 KHz

LF Antenna normal operating voltage	90 ~ 135 Vpp
LF Antenna inductance(with lock)	440 μ H
LF Antenna quality factor(with lock)	≥ 10
LF antenna/TxP coupling factor	$\geq 2\%$
Rated voltage	7V - 16V
Rated current	<150 mA
Maximum operating temperature	-40 C to +85C
Maximum altitude	5000m

3. Block Diagram

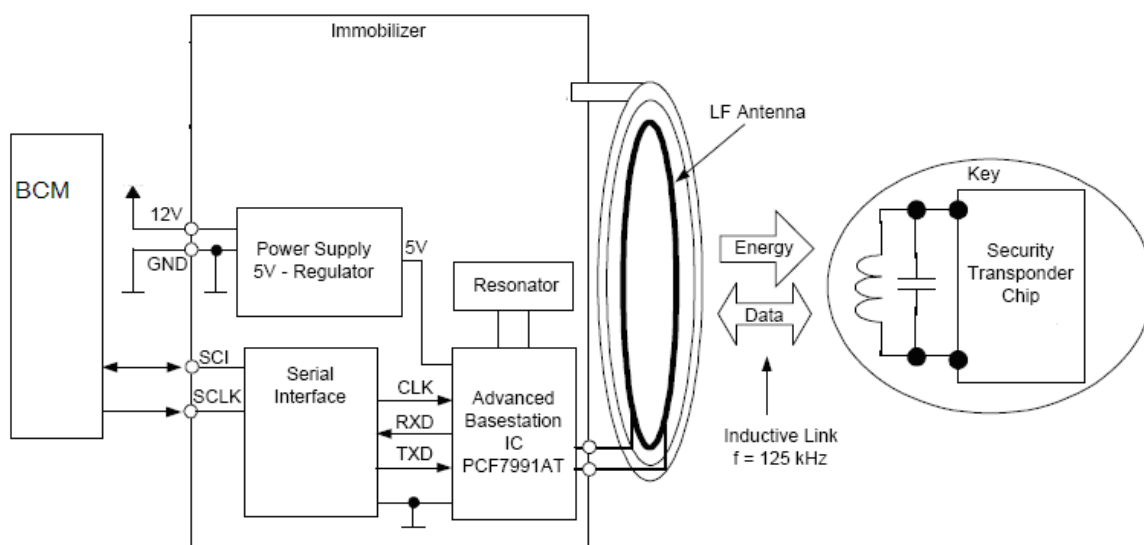

This device complies with part 15 of the FCC Rules. Operation is subject to the following two conditions: (1) This device may not cause harmful interference, and (2) this device must accept any interference received, including interference that may cause undesired operation.

FCC statement

This equipment has been tested and found to comply with the limits for a Class B digital device, pursuant to Part 15 of the FCC Rules. These limits are designed to provide reasonable protection against harmful interference in a residential installation. This equipment generates, uses and can radiate radio frequency energy and, if not installed and used in accordance with the instructions, may cause harmful interference to radio communications.

However, there is no guarantee that interference will not occur in a particular installation.

- If this equipment does cause harmful interference to radio or television reception, which can be determined by turning the equipment off and on, the user is encouraged to try to correct the interference by one or more of the following measures:

- Reorient or relocate the receiving antenna.

- Increase the separation between the equipment and receiver.

- Connect the equipment into an outlet on a circuit different from that to which the receiver is connected.

- Consult the dealer or an experienced radio/TV technician for help.

RF exposure warning

- The equipment complies with FCC RF exposure limits set forth for an uncontrolled environment.

The equipment must not be co-located or operating in conjunction with any other antenna or transmitter.

NOTE: Any changes or modifications not expressly approved by the grantee of this device could void the user's authority to operate the equipment.