

FCC RADIO TEST REPORT

FCC 47 CFR PART 15 SUBPART C

Class II Permissive Change

Test Standard	FCC Part 15.231
Trade name	Continental
Product name	Radio Frequency Transmitter(Key Fob)
Model No.	IK4CH-01
Operation Freq.	433.92 MHz
Test Result	Pass
Statements of Conformity	Determination of compliance is based on the results of the compliance measurement, not taking into account measurement instrumentation uncertainty.

The test Result was tested by Compliance Certification Services Inc. The test data, data evaluation, test procedures, and equipment configurations shown in this report were given in ANSI C63.10: 2013 and compliance standards.

The test results of this report relate only to the tested sample (EUT) identified in this report.

The test Report of full or partial shall not copy. Without written approval of SGS Compliance Certification Services Inc. (Wugu Laboratory)

Approved by:

Reviewed by:



Kevin Tsai
Deputy Manager

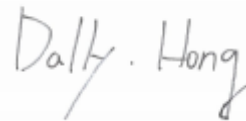

Dally Hong
Engineer

Unless otherwise stated the results shown in this test report refer only to the sample(s) tested and such sample(s) are retained for 90 days only.
除非另有說明，此報告結果僅對測試之樣品負責，同時此樣品僅保留90天。本報告未經本公司書面許可，不可部分複製。

This document is issued by the Company subject to its General Conditions of Service printed overleaf, available on request or accessible at www.sgs.com/terms_and_conditions.htm and for electronic format documents, subject to Terms and Conditions for Electronic Documents at www.sgs.com/terms_e-document.htm. Attention is drawn to the limitation of liability, indemnification and jurisdiction issues defined therein. Any holder of this document is advised that information contained hereon reflects the Company's findings at the time of its intervention only and within the limits of Client's instructions, if any. The Company's sole responsibility is to its Client and this document does not exonerate parties to a transaction from exercising all their rights and obligations under the transaction documents. This document cannot be reproduced except in full, without prior written approval of the Company. Any unauthorized alteration, forgery or falsification of the content or appearance of this document is unlawful and offenders may be prosecuted to the fullest extent of the law.



Report No.: T190701W02-RP

Page: 2 / 29

Rev.: 01

Revision History

Rev.	Issue Date	Revisions	Effect Page	Revised By
00	July 15, 2019	Initial Issue	ALL	Allison Chen
01	July 26, 2019	See the following Note Rev. (01)	P.2, P.4, P.18-19, A-1~2	Allison Chen

Rev.(01)

1. Revised test setup photo.
2. Revised revision history and version of test report.
3. Revised C2PC description column in section 1.1.
4. Added note (average result) for test data in section 4.3.4.
5. Removed KDB 937606.



Table of contents

1. GENERAL INFORMATION	4
1.1 EUT INFORMATION	4
1.2 EUT CHANNEL INFORMATION	5
1.3 ANTENNA INFORMATION	5
1.4 MEASUREMENT UNCERTAINTY	6
1.5 FACILITIES AND TEST LOCATION	6
1.6 INSTRUMENT CALIBRATION	7
1.7 SUPPORT AND EUT ACCESSORIES EQUIPMENT	8
1.8 TEST METHODOLOGY AND APPLIED STANDARDS	8
2. TEST SUMMERY	9
3. DESCRIPTION OF TEST MODES	10
3.1 THE WORST MODE OF OPERATING CONDITION	10
3.2 THE WORST MODE OF MEASUREMENT	10
3.3 EUT DUTY CYCLE	11
4. TEST RESULT	12
4.1 AC POWER LINE CONDUCTED EMISSION	12
4.2 EMISSION BANDWIDTH	13
4.3 FIELD STRENGTH OF FUNDAMENTAL	15
4.4 RADIATION UNWANTED EMISSION	20
4.5 OPERATION RESTRICTION	28
APPENDIX 1 – PHOTOGRAPHS OF EUT	

1. GENERAL INFORMATION

1.1 EUT INFORMATION

Applicant	Continental Automotive GmbH Siemensstrasse 12, 93055, Regensburg, Germany
Factory	Continental Automotive France SAS 1 Avenue Paul OURLIAC, 31100 Toulouse, Cedex 1, FRANCE
Equipment	Radio Frequency Transmitter(Key Fob)
Model Name	IK4CH-01
Model Discrepancy	N/A
Original Received Date	April 25, 2017
Update Received Date	May 17, 2019
Original Date of Test	April 13 ~ May 02, 2018
Update Date of Test	May 21 ~ 27, 2019
Periodic operation	<input checked="" type="checkbox"/> (1) A manually operated transmitter shall employ a switch that will automatically deactivate the transmitter within not more than 5 seconds of being released. <input type="checkbox"/> (2) A transmitter activated automatically shall cease transmission within 5 seconds after activation <input type="checkbox"/> (3) Periodic transmissions at regular predetermined intervals are not permitted. <input type="checkbox"/> (4) Periodic transmissions (lower field strength): each transmission is not greater than 1 sec and the silent period between transmissions is at least 30 times the duration of the transmission but in no case less than 10 sec.
Power Operation	Lithium battery: 3V
Class II Permissive Change	1. Added one plastic case in this report. 2. Perform radiated emission and the field strength of the fundamental frequency to verify the change. The test results of EUT Duty Cycle, Emission Bandwidth and Operation Restriction were referred from the original report: T170425W05-RP.

1.2 EUT CHANNEL INFORMATION

Frequency Range	433.92 MHz
Modulation Type	FSK
Bandwidth	208.393 kHz
Number of Channels	1 channel

Remark:

Refer as ANSI 63.10:2013 clause 5.6.1 Table 4 for test channels.

Number of frequencies to be tested		
Frequency range in which device operates	Number of frequencies	Location in frequency range of operation
<input checked="" type="checkbox"/> 1 MHz or less	1	Middle
<input type="checkbox"/> 1 MHz to 10 MHz	2	1 near top and 1 near bottom
<input type="checkbox"/> More than 10 MHz	3	1 near top, 1 near middle, and 1 near bottom

1.3 ANTENNA INFORMATION

Antenna Type	PCB Antenna
Antenna Gain	-17dBi

1.4 MEASUREMENT UNCERTAINTY

PARAMETER	UNCERTAINTY
AC Powerline Conducted Emission	+/- 1.2575
Emission bandwidth, 20dB bandwidth	+/- 0.0014
RF output power, conducted	+/- 1.14
Power density, conducted	+/- 1.40
3M Semi Anechoic Chamber / 30M~200M	+/- 4.12
3M Semi Anechoic Chamber / 200M~1000M	+/- 4.68
3M Semi Anechoic Chamber / 1GHz~8GHz	+/- 5.18
3M Semi Anechoic Chamber / 8GHz~18GHz	+/- 5.47
3M Semi Anechoic Chamber / 18GHz~26GHz	+/- 3.81
3M Semi Anechoic Chamber / 26GHz~40GHz	+/- 3.87

Remark:

1. This uncertainty represents an expanded uncertainty expressed at approximately the 95% confidence level using a coverage factor of $k=2$
2. ISO/IEC 17025 requires that an estimate of the measurement uncertainties associated with the emissions test results be included in the report.

1.5 FACILITIES AND TEST LOCATION

All measurement facilities used to collect the measurement data are located at
No.11, Wugong 6th Rd., Wugu Dist., New Taipei City 24891, Taiwan. (R.O.C.)

Test site	Test Engineer	Remark
AC Conduction Room	N/A	Not applicable
Radiation	Dally Hong	-
RF Conducted	Dally Hong	-

Remark: The sites are constructed in conformance with the requirements of ANSI C63.7, ANSI C63.4 and CISPR Publication 22.



1.6 INSTRUMENT CALIBRATION

Original: Chrome Variant

RF Conducted Test Site					
Equipment	Manufacturer	Model	S/N	Cal Date	Cal Due
Spectrum Analyzer	R&S	FSV 40	101073	10/02/2017	10/01/2018
Directional Coupler	Agilent	87301D	MY44350252	07/25/2017	07/24/2018
SUCOFLEX Cable	HUBER SUHNER	SUCOFLEX 104PEA	25157	07/31/2017	07/30/2018
Divider	Solvang Technology	2-18GHz 4Way	STI08-0015	07/26/2017	07/25/2018

3M 966 Chamber Test Site					
Equipment	Manufacturer	Model	S/N	Cal Date	Cal Due
Bilog Antenna	Sunol Sciences	JB3	A030105	06/20/2017	06/19/2018
Pre-Amplifier	EMEC	EM330	60609	06/07/2017	06/06/2018
Spectrum Analyzer	Agilent	E4446A	US42510252	11/27/2017	11/26/2018
Loop Ant	COM-POWER	AL-130	121051	03/21/2018	03/20/2019
Antenna Tower	CCS	CC-A-1F	N/A	N.C.R	N.C.R
Controller	CCS	CC-C-1F	N/A	N.C.R	N.C.R
Turn Table	CCS	CC-T-1F	N/A	N.C.R	N.C.R
Pre-Amplifier	HP	8449B	3008A00965	06/27/2017	06/26/2018
Filter	N/A	580-6000	N/A	N/A	N/A
Cable	HUBER SUHNER	SUCOFLEX 104PEA	25157	07/31/2017	07/30/2018
Cable	HUBER SUHNER	SUCOFLEX 104PEA	20995	07/31/2017	07/30/2018

Remark: Each piece of equipment is scheduled for calibration once a year.

Addition: Plastic Variant for section 4.3 and 4.4

3M 966 Chamber Test Site					
Equipment	Manufacturer	Model	S/N	Cal Date	Cal Due
Bilog Antenna	Sunol Sciences	JB3	A030105	07/13/2018	07/12/2019
Cable	HUBER SUHNER	SUCOFLEX 104PEA	25157	02/26/2019	02/25/2020
Cable	HUBER SUHNER	SUCOFLEX 104PEA	20995	02/26/2019	02/25/2020
Digital Thermo-Hygro Meter	WISEWIND	1206	D07	01/30/2019	01/29/2020
Double Ridged Guide Horn Antenna	ETC	MCTD 1209	DRH13M02003	08/20/2018	08/19/2019
High Pass Filter	SOLVANG TECHNOLOGY INC.	ST115	9923	02/26/2019	02/25/2020
Loop Ant	COM-POWER	AL-130	121051	03/22/2019	03/21/2020
Pre-Amplifier	EMEC	EM330	060609	02/26/2019	02/25/2020
Pre-Amplifier	HP	8449B	3008A00965	02/26/2019	02/25/2020
PSA Series Spectrum Analyzer	Agilent	E4446A	MY46180323	05/31/2018	05/30/2019
Antenna Tower	CCS	CC-A-1F	N/A	N.C.R	N.C.R
Controller	CCS	CC-C-1F	N/A	N.C.R	N.C.R
Turn Table	CCS	CC-T-1F	N/A	N.C.R	N.C.R
Software	e3 6.11-20180413				

Remark: Each piece of equipment is scheduled for calibration once a year.

1.7 SUPPORT AND EUT ACCESSORIES EQUIPMENT

There are no accessories and support equipment be used during the test.

EUT Accessories Equipment					
No.	Equipment	Brand	Model	Series No.	FCC ID
	N/A				

Support Equipment					
No.	Equipment	Brand	Model	Series No.	FCC ID
	N/A				

1.8 TEST METHODOLOGY AND APPLIED STANDARDS

The test methodology, setups and results comply with all requirements in accordance with ANSI C63.10:2013, FCC 15.231 Rules.



Report No.: T190701W02-RP

Page: 9 / 29

Rev.: 01

2. TEST SUMMERY

Standard Sec.	Chapter	Test Item	Result
15.203	1.2	Antenna Requirement	Pass
15.207	4.1	AC Power-line Conducted Emission	Not applicable
15.231(c)	4.2	Emission Bandwidth	Pass
15.231(b)	4.3	Fundamental Emission	Pass
15.209(b)	4.4	Radiation Unwanted Emission	Pass
15.231(a)(1)	4.5	Operation Restriction	Pass

3. DESCRIPTION OF TEST MODES

3.1 THE WORST MODE OF OPERATING CONDITION

Operation mode	433.92 MHz			
RF Field strength		Variant	Result	worst case
	Original	Chorme	Peak: 80.28 dBuv/m Average : 72.65 dBuv/m	X
	Additional	Plastic	Peak: 84.58 dBuv/m Average: 76.95 dBuv/m	V

Remark: Field strength performed Average level at 3m.

3.2 THE WORST MODE OF MEASUREMENT

Radiated Emission Measurement Above 1G	
Test Condition	Band edge, Emission for Unwanted and Fundamental
Power supply Mode	Mode 1: EUT power by Battery 3 v
Worst Mode	<input checked="" type="checkbox"/> Mode 1 <input type="checkbox"/> Mode 2 <input type="checkbox"/> Mode 3 <input type="checkbox"/> Mode 4
Worst Position	<input type="checkbox"/> Placed in fixed position. <input type="checkbox"/> Placed in fixed position at X-Plane (E2-Plane) <input type="checkbox"/> Placed in fixed position at Y-Plane (E1-Plane) <input checked="" type="checkbox"/> Placed in fixed position at Z-Plane (H-Plane)
Worst Polarity	<input checked="" type="checkbox"/> Horizontal <input checked="" type="checkbox"/> Vertical

Radiated Emission Measurement Below 1G	
Test Condition	Radiated Emission Below 1G
Power supply Mode	Mode 1: EUT power by Battery 3 v
Worst Mode	<input checked="" type="checkbox"/> Mode 1 <input type="checkbox"/> Mode 2 <input type="checkbox"/> Mode 3 <input type="checkbox"/> Mode 4

Remark:

1. The worst mode was record in this test report.
2. EUT pre-scanned in three axis ,X,Y, Z and two polarity, Horizontal and Vertical for radiated measurement. The worst case(Z-Plane and Vertical) were recorded in this report

Report No.: T190701W02-RP

3.3 EUT DUTY CYCLE

Duty Cycle	
TX ON (ms)	Duty Factor(dB)
41.542	<u>-7.63</u>

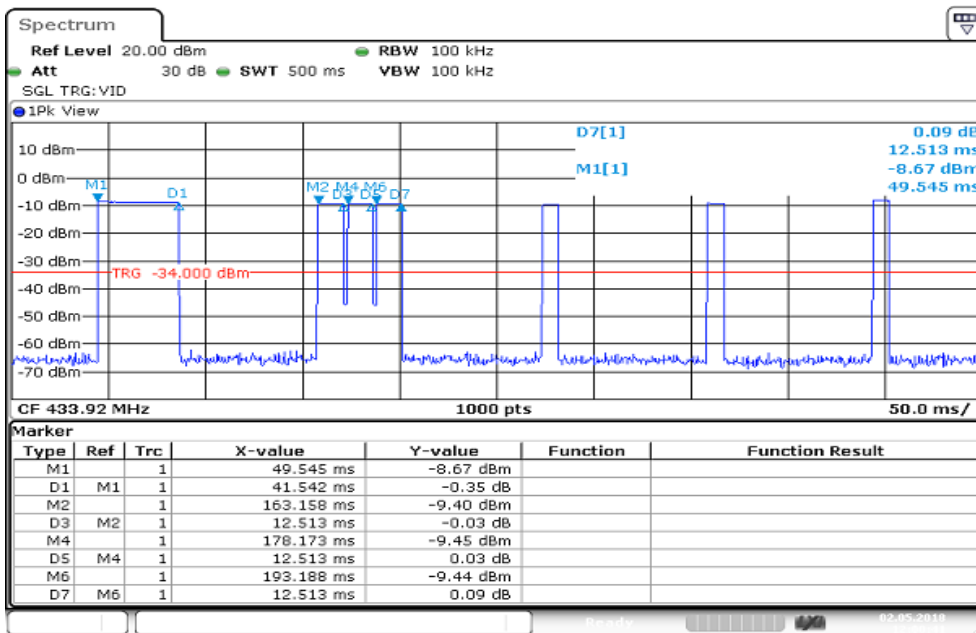

Date: 2.MAY.2018 12:00:41

Notes:

1. The transmitter duty cycle was measured using a spectrum analyser in the time domain and calculated by $20 \log(\text{Time}_{(on)} / [\text{Period or } 100 \text{ ms whichever is the lesser}])$
2. The EUT transmits for a $\text{Time}_{(on)}$ of 41.542 milliseconds within the specified 100ms period.
 $20 \log (\text{Time}_{(on)} / [\text{Period or } 100 \text{ ms whichever is the lesser}])$.
 $20 \log (41.542 / 100) = -7.63 \text{ dB}$

4. TEST RESULT

4.1 AC POWER LINE CONDUCTED EMISSION

4.1.1 Test Limit

According to §15.207(a),

Frequency Range (MHz)	Limits(dBµV)	
	Quasi-peak	Average
0.15 to 0.50	66 to 56*	56 to 46*
0.50 to 5	56	46
5 to 30	60	50

* Decreases with the logarithm of the frequency.

4.1.2 Test Procedure

Test method Refer as ANSI 63.10:2013 clause 6.2,

1. The EUT was placed on a table, which is 0.8m above ground plane.
2. Maximum procedure was performed on the six highest emissions to ensure EUT compliance.
3. Repeat above procedures until all frequency measured were complete

4.1.3 Test Setup

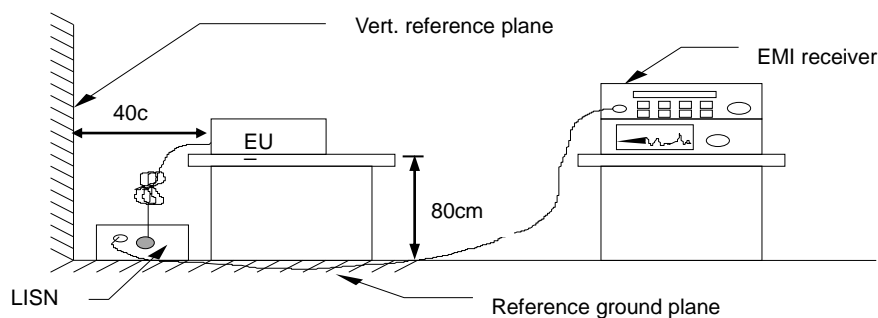

4.1.4 Test Result

Not applicable

4.2 EMISSION BANDWIDTH

4.2.1 Test Limit

According to §15.231(c) ,

Limit	<input checked="" type="checkbox"/> 70 MHz - 900 MHz : $F_c * 0.25 \%$ <input type="checkbox"/> Above 900 MHz : $F_c * 0.5 \%$
-------	---

4.2.2 Test Procedure

Test method Refer as ANSI 63.10:2013 clause 6.9.2,

The Loop antenna connected to the spectrum analyzer, was touching to the transmitter antenna. Set the RBW=10KHz, VBW $\geq 3 \times$ RBW, Detector = Peak, Trace mode = Max hold, Sweep = Auto. Measure the maximum width of the emission that is constrained by the frequencies associated with the 20dB Bandwidth and Occupied Bandwidth(99%).

4.2.3 Test Setup

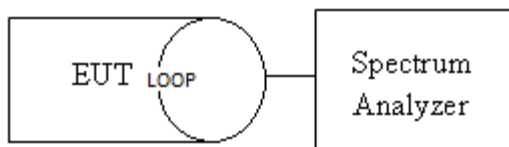

Report No.: T190701W02-RP

4.2.4 Test Result

Spectrum Bandwidth			
Frequency (MHz)	99% Occupied BW (KHz)	20dB Bandwidth (KHz)	20dB Bandwidth Limits (MHz)
433.92	208.393	205.50	1.08

Test Data

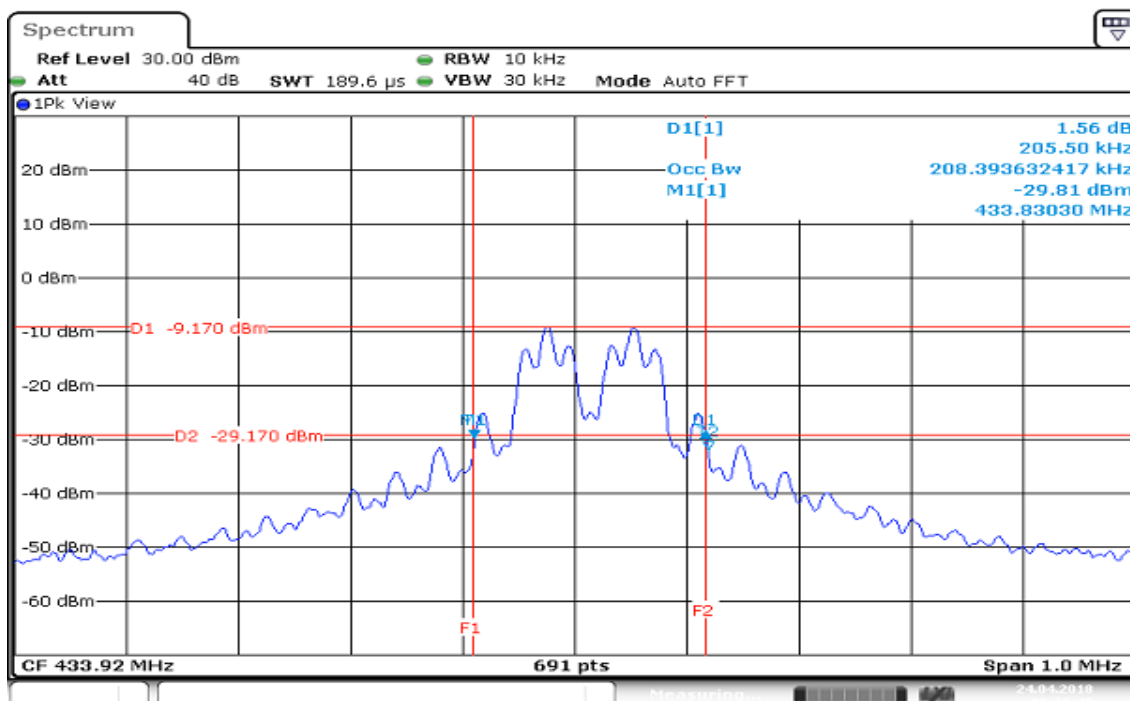

Date: 24.APR.2018 09:20:48

4.3 FIELD STRENGTH OF FUNDAMENTAL

4.3.1 Test Limit

According to §15.231(b)

Fundamental frequency (MHz)	Field strength of fundamental (uv/m) at 3m	Field strength of fundamental (dBuv/m) at 3m
40.66-40.70	2,250	67
70-130	1,250	61.9
*130-174	*1,250 to 3,750	61.9-71.5
174-260	3,750	71.5
*260-470	*3,750 to 12,500	71.5-81.9
Above 470	12,500	81.9

REMARK:

1. Linear interpolations
2. Based on the average value of the measured Field strength of fundamental.

4.3.2 Test Procedure

Test method Refer as ANSI 63.10:2013 clause 4.1.4 and clause 6.5

clause 4.1.4	<input checked="" type="checkbox"/> 4.1.4.2.2: Measurement Peak value. <input type="checkbox"/> 4.1.4.2.3: Duty cycle ≥ 100%. <input checked="" type="checkbox"/> 4.1.4.2.4: Measurement Average value.
--------------	---

4.3.3 Test Setup

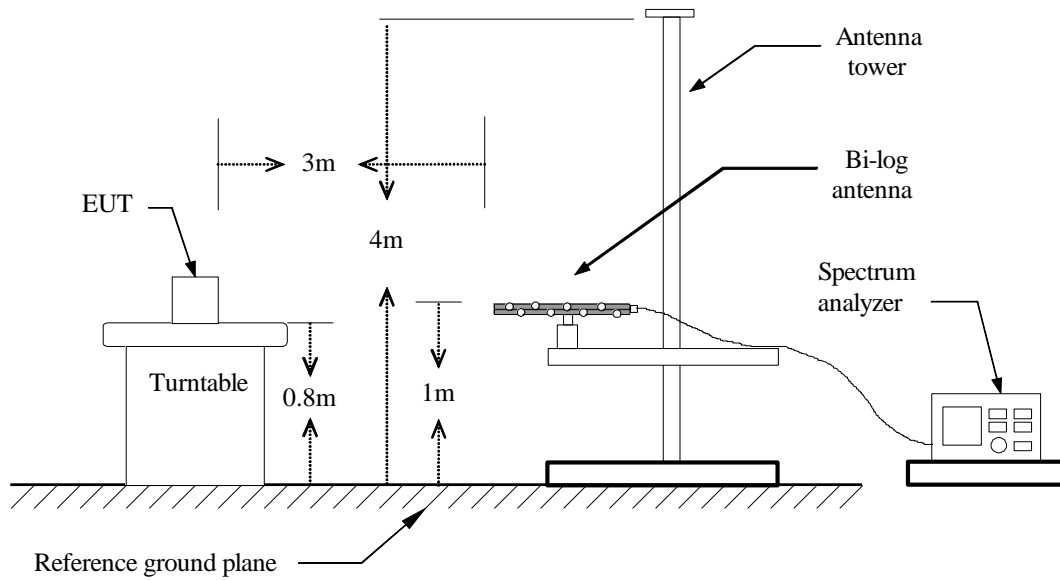

4.3.4 Test Result

Original: Chorme Variant

Field Strength					
Frequency (MHz)	Fundamental (dBuV/m) at 3m	Limit (dBuV/m) at 3m	Margin (dB)	Axis/Pol.	Remark
433.92	72.65	80.82	-8.17	Z/V	Average
433.92	80.28	100.82	-20.54	Z/V	Peak

Remark:

1. Fundamental measured method setting on spectrum, RBW=100 kHz, VBW=100kHz and Detector=Peak.
2. Average result = Peak result + Duty factor = 80.28 dBuV/m – 7.63 = 72.65 dBuV/m
3. 260MHz ~ 470MHz limit is $41.6667 * (\text{Frequency, MHz}) - 7083.3333$
 $\text{Limit} = 41.6667 * (433.92\text{MHz}) - 7083.3333 = 10996.68116 \text{ (uV/m)}$
 $\text{dBuV/m} = 20\text{Log}(10996.68116 \text{ uV/m}) = 80.82 \text{ dBuV/m}$

Additional: Plastic Variant

Field Strength					
Frequency (MHz)	Fundamental (dBuV/m) at 3m	Limit (dBuV/m) at 3m	Margin (dB)	Axis/Pol.	Remark
433.92	76.95	80.82	-3.87	Z/H	Average
433.92	84.58	100.82	-16.24	Z/H	Peak

Remark:

1. Fundamental measured method setting on spectrum, RBW=100 kHz, VBW=100kHz and Detector=Peak.
2. Vertical: Average result = Peak result + Duty factor = 84.56 dBuV/m – 7.63 = 76.93 dBuV/m
Horizontal: Average result = Peak result + Duty factor = 84.58 dBuV/m – 7.63 = 76.95 dBuV/m
3. 260MHz ~ 470MHz limit is $41.6667 * (\text{Frequency, MHz}) - 7083.3333$
 $\text{Limit} = 41.6667 * (433.92\text{MHz}) - 7083.3333 = 10996.68116 \text{ (uV/m)}$
 $\text{dBuV/m} = 20\text{Log}(10996.68116 \text{ uV/m}) = 80.82 \text{ dBuV/m}$

Test Data

Original: Chorme Variant

Test Mode:	TX	Temp/Hum	22(°C)/ 34%RH
Test Item	Fundamental	Test Date	2018/04/13
Axis/Polarize	Z-Plane/Ver	Test Engineer	Jerry Chuang
Detector	Peak	Test Voltage:	3Vdc

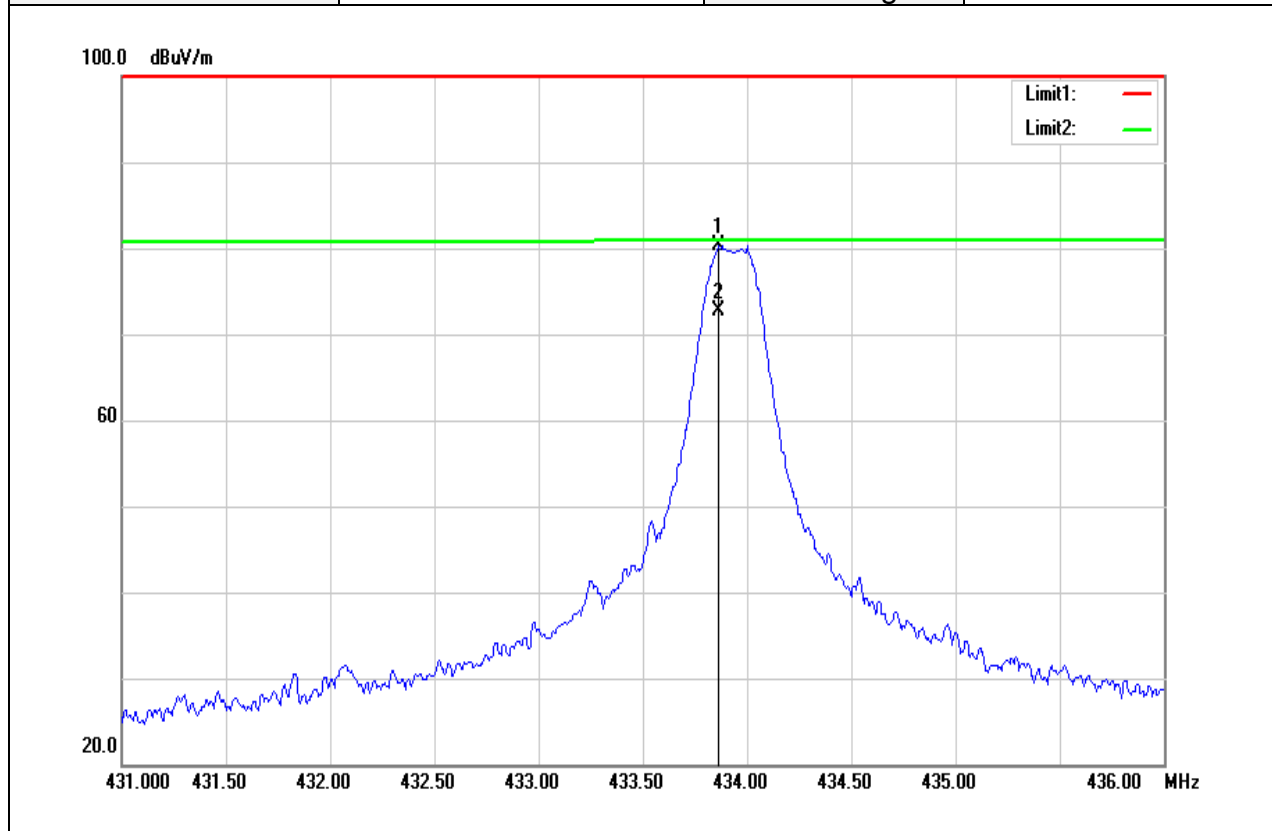

No	Frequency (MHz)	Reading (dBuV)	Correct Factor(dB/m)	Result (dBuV/m)	Limit (dBuV/m)	Margin (dB)	Remark
1	433.8650	90.45	-10.17	80.28	100.82	-20.54	peak

Note: Point No.2 Average result = Peak result + Duty factor
= 80.28 dBuV/m -7.63= 72.65dBuV/m

Additional: Plastic Variant

Test Mode:	TX	Temp/Hum	20(°C)/ 52%RH
Test Item	Fundamental	Test Date	2019/05/27
Axis/Polarize	Z-Plane/Hor.	Test Engineer	Dally Hong
Detector	Peak		

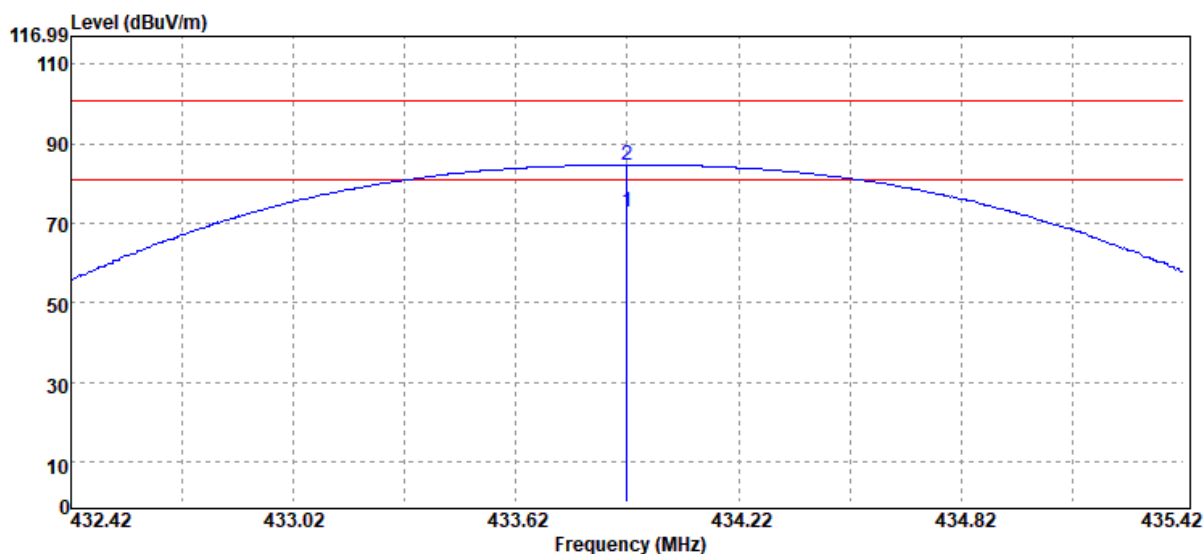

No	Frequency (MHz)	Reading (dBuV)	Correct Factor(dB/m)	Result (dBuV/m)	Limit (dBuV/m)	Margin (dB)	Remark
2	433.92	88.81	-4.23	84.58	100.82	-16.24	Peak

Note: Point No.1 Average result = Peak result + Duty factor
 = 84.58 dBuV/m -7.63= 72.6.95dBuV/m

4.4 RADIATION UNWANTED EMISSION

4.4.1 Test Limit

According to §15.231(e) and §15.209

Unwanted emissions limit follow the table or the FCC Part 15.209, whichever limit permits higher field strength.

According to §15.231(b)

Fundamental frequency (MHz)	Field strength of Spurious emission (uv/m) at 3m	Field strength of Spurious emission (dBuv/m) at 3m
40.66-40.70	225	47
70-130	125	41.9
*130-174	*125-375	41.9-51.5
174-260	375	51.5
*260-470	*375-1250	51.5-61.9
Above 470	1250	61.9

REMARK:

1. Linear interpolations
2. Based on the average value of the measured Field strength of fundamental.

Below 30MHz

Frequency (MHz)	Field Strength				
	(μ V/m)	(dB μ V/m)	Measurement Distance (meter)	(dB μ V/m)	Measurement Distance (meter)
0.009 - 0.490	2400/F(kHz)	48.52 – 13.80	300	128.52–104.84	3
0.490 - 1.705	24000/F(kHz)	33.80 – 22.97	30	73.80– 62.97	3
1.705 – 30.0	30	29.54	30	69.54	3

Above 30MHz

Frequency (MHz)	Field Strength		Measurement Distance (meter)
	(μ V/m)	(dB μ V/m)	
30-88	100	40.0	3
88-216	150	43.5	3
216-960	200	46.0	3
Above 960	500	54.0	3

4.4.2 Test Procedure

Test method Refer as ANSI 63.10:2013

<input checked="" type="checkbox"/> Unwanted Emission	<input checked="" type="checkbox"/> clause 4.1.4.2.2: Measurement Peak value. <input type="checkbox"/> clause 4.1.4.2.3: Duty cycle \geq 100%. <input checked="" type="checkbox"/> clause 4.1.4.2.4: Measurement Average value.
---	---

<input checked="" type="checkbox"/> Radiated Emission	<input checked="" type="checkbox"/> clause 6.4: below 30 MHz and test distance is 3m. <input checked="" type="checkbox"/> clause 6.5: below 30 MHz -1 GHz and test distance is 3m. <input checked="" type="checkbox"/> clause 6.6: Above 30 MHz and test distance is 3m.
---	--

1. The EUT is placed on a turntable, which is 0.8m for test below 1GHz and 1.5m for test above 1GHz, above ground plane.
2. The turntable shall be rotated for 360 degrees to determine the position of maximum emission level.
3. EUT is set 3m away from the receiving antenna, which is varied from 1m to 4m to find out the highest emissions.
4. Maximum procedure was performed on the six highest emissions to ensure EUT compliance.
5. And also, each emission was to be maximized by changing the polarization of receiving antenna both horizontal and vertical.
6. Set the spectrum analyzer in the following setting as:

Below 1GHz:

RBW=100kHz / VBW=300kHz / Sweep=AUTO

Above 1GHz:

(a)PEAK: RBW=1MHz / VBW=3MHz / Sweep=AUTO

(b)AVERAGE: RBW=1MHz,

7. Repeat above procedures until the measurements for all frequencies are complete.

Remark.

1. The EUT has a oscillator operating at 27.6 MHz, harmonic/spurious was verified. And didn't catch any emission at 27.6MHz.
2. Although these tests were performed other than open area test site, adequate comparison measurements were confirmed against 30 m open are test site. Therefore sufficient tests were made to demonstrate that the alternative site produces results that correlate with the ones of tests made in an open field based on KDB 414788.
3. No emission found between lowest internal used/generated frequency to 30MHz (9kHz~30MHz).

4.4.3 Test Setup

9kHz ~ 30MHz

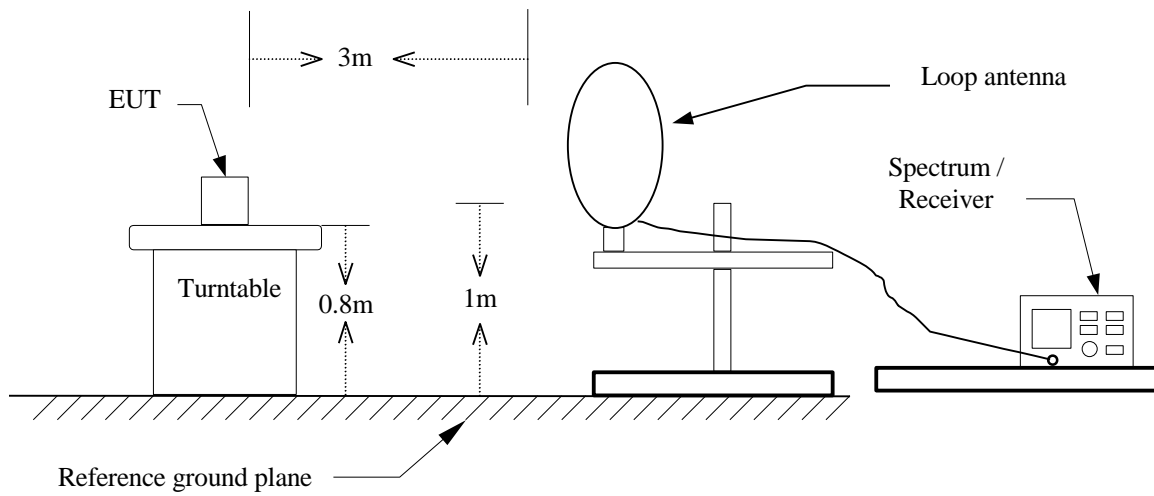

30MHz ~ 1 GHz

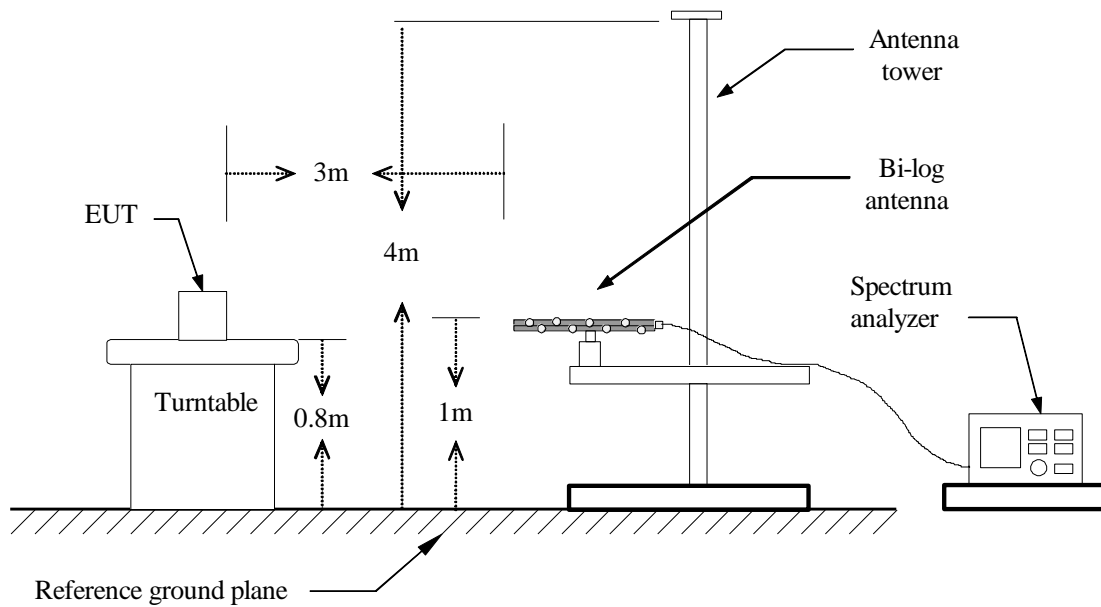

Above 1 GHz

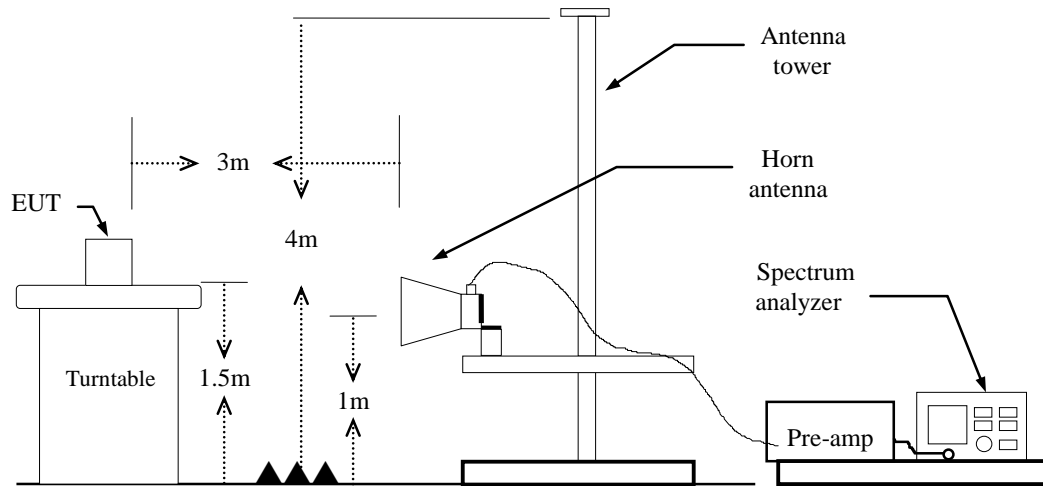

4.4.4 Test Result

Pass.

Test Data

Below 1GHz

Test Mode:	TX	Temp/Hum	20(°C)/ 51%RH
Test Item	Below 1GHz	Test Date	2019/05/21
Polarize	Vertical	Test Engineer	Dally Hong
Detector	Peak		

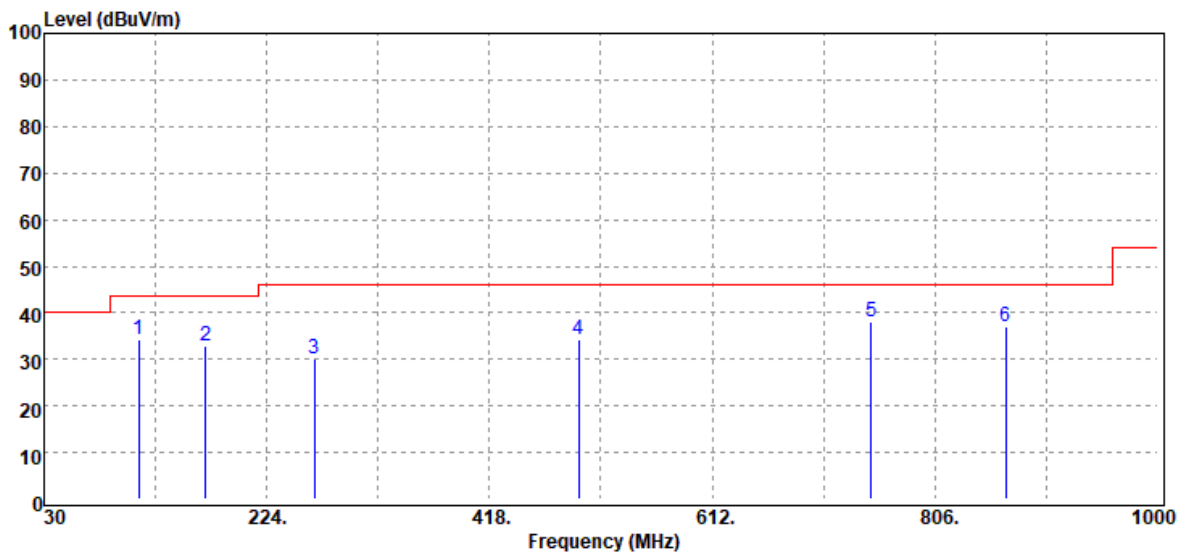

Frequency (MHz)	Reading (dBuV)	Correction Factor (dB/m)	Result (dBuV/m)	Limit (dBuV/m)	Margin (dB)	Remark
112.45	43.93	-9.65	34.28	43.50	-9.22	peak
170.65	43.76	-10.83	32.93	43.50	-10.57	peak
265.71	39.00	-8.88	30.12	46.00	-15.88	peak
495.60	37.45	-3.04	34.41	46.00	-11.59	peak
750.71	35.98	2.18	38.16	46.00	-7.84	peak
867.84	34.07	2.92	36.99	46.00	-9.01	peak

Test Mode:	TX	Temp/Hum	20(°C)/ 51%RH
Test Item	Below 1GHz	Test Date	2019/05/21
Polarize	Horizontal	Test Engineer	Dally Hong
Detector	Peak		

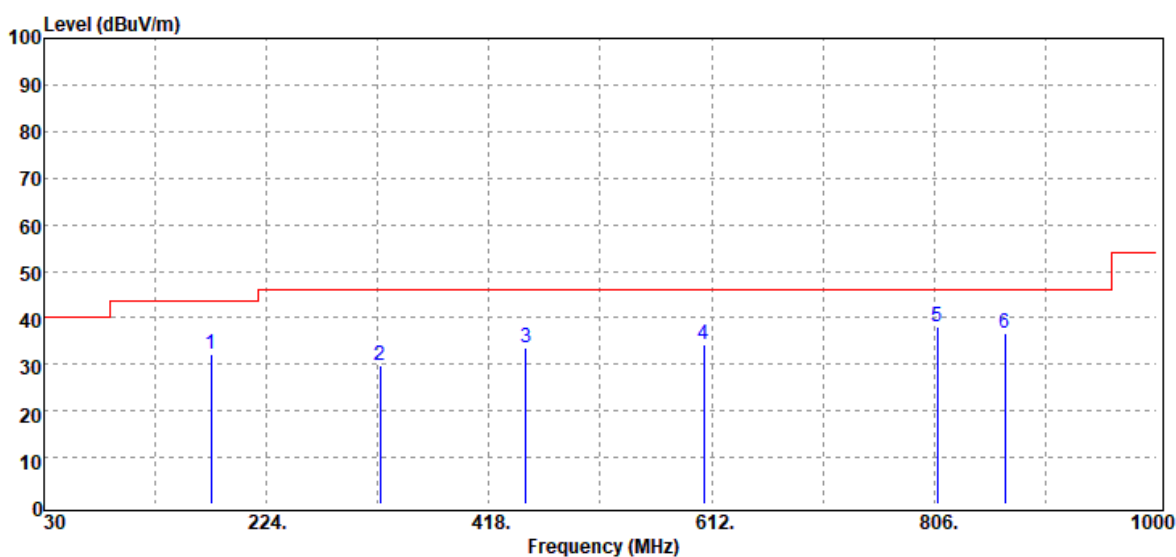

Frequency (MHz)	Reading (dBuV)	Correction Factor (dB/m)	Result (dBuV/m)	Limit (dBuV/m)	Margin (dB)	Remark
175.50	43.25	-11.11	32.14	43.50	-11.36	peak
322.94	37.03	-7.37	29.66	46.00	-16.34	peak
450.01	37.59	-3.88	33.71	46.00	-12.29	peak
605.21	35.77	-1.43	34.34	46.00	-11.66	peak
808.91	36.02	2.19	38.21	46.00	-7.79	peak
867.84	33.62	2.92	36.54	46.00	-9.46	peak

Above 1GHz

Test Mode:	TX	Temp/Hum	20(°C)/ 52%RH
Test Item	Above 1GHz	Test Date	2019/05/21
Polarize	Vertical	Test Engineer	Dally Hong
Detector	Peak		

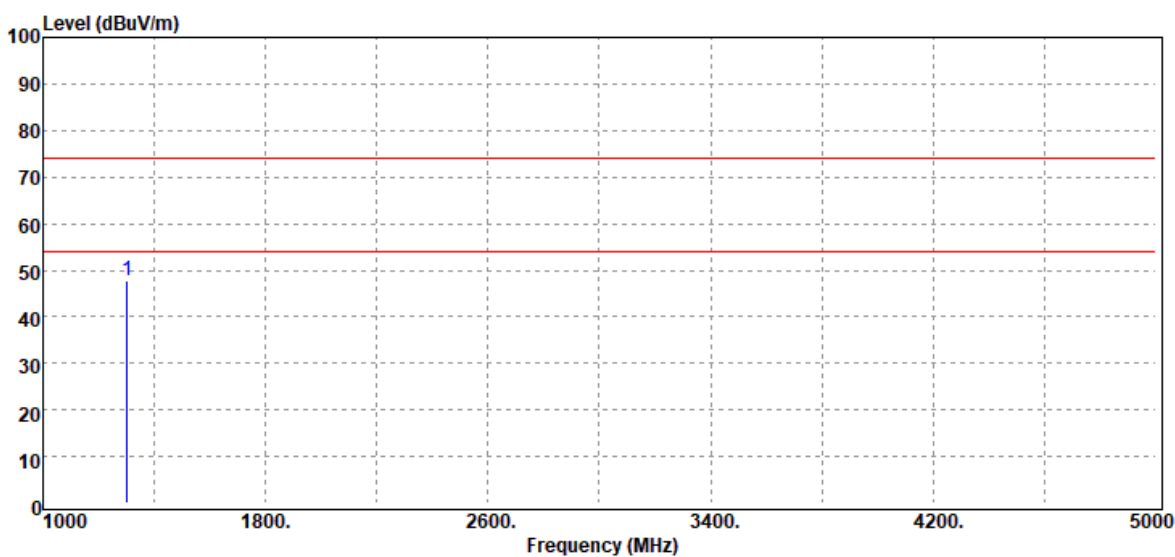

Frequency (MHz)	Reading (dBuV)	Correction Factor (dB/m)	Result (dBuV/m)	Limit (dBuV/m)	Margin (dB)	Remark
1301.76	55.82	-8.11	47.71	74.00	-26.29	peak
N/A						

Remark:

1. Measuring frequencies from 1 GHz to the 10th harmonic of highest fundamental frequency.

Test Mode:	TX	Temp/Hum	20(°C)/ 52%RH
Test Item	Above 1GHz	Test Date	2019/05/21
Polarize	Horizontal	Test Engineer	Dally Hong
Detector	Peak		

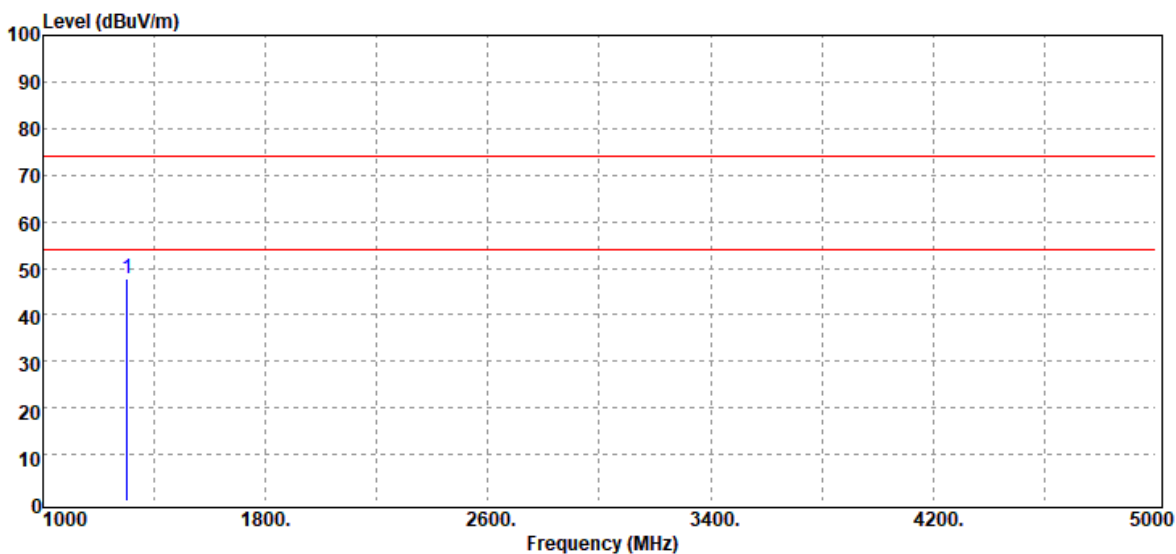

Frequency (MHz)	Reading (dBuV)	Correction Factor (dB/m)	Result (dBuV/m)	Limit (dBuV/m)	Margin (dB)	Remark
1301.76	55.96	-8.11	47.85	74.00	-26.15	peak
N/A						

Remark:

1. Measuring frequencies from 1 GHz to the 10th harmonic of highest fundamental frequency.

4.5 OPERATION RESTRICTION

4.5.1 Test Limit

15.231(a)(1), A manually operated transmitter shall employ a switch that will automatically deactivate the transmitter within not more than 5 seconds of being released.

4.5.2 Test Procedure

Test method Refer as ANSI 63.10:2013 clause 7.4

The Loop antenna connected to the spectrum analyzer, was touching to the transmitter antenna. Set the RBW=1MHz, VBW $\geq 3 \times$ RBW, Detector = Peak, Trace mode = Max hold, Sweep = 5s.Measure

4.5.3 Test Setup

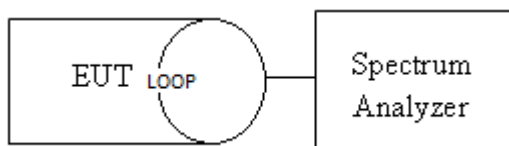

4.5.4 Test Result

Dwell Time		
Operation condition	Burst Duration	Limits
Automatically Operated	340.58 ms	5 sec

Test Data

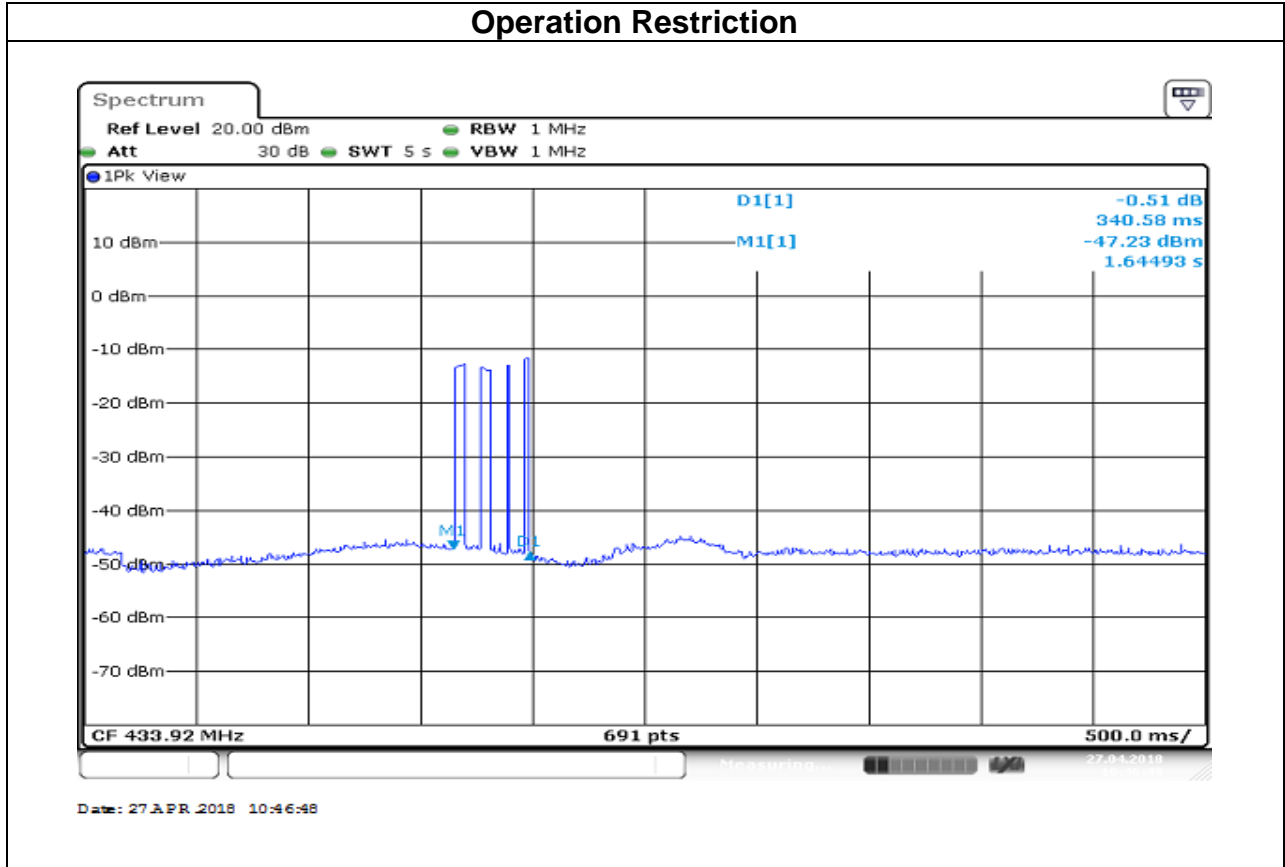

--End of Report--