

FCC 47 CFR PART 15 SUBPART B REPORT

ISED ICES-003 TEST REPORT

For

Hand Free Module

MODEL: HFM201

Issued for

Continental Automotive Technologies GmbH

Siemensstrasse 12 93055 Regensburg Germany

Issued By:

Compliance Certification Services Inc.

Wugu Laboratory

No.11, Wugong 6th Rd., Wugu Dist.,
New Taipei City, Taiwan.

Issued Date: December 13, 2022

Note: This document may be altered or revised by Compliance Certification Services Inc. personnel only, and shall be noted in the revision section of the document. The client should not use it to claim product endorsement by TAF, NIST or any government agencies. The test results in the report only apply to the tested sample.

Unless otherwise stated the results shown in this test report refer only to the sample(s) tested and such sample(s) are retained for 90 days only.

除非另有說明，此報告結果僅對測試之樣品負責，同時此樣品僅保留90天。本報告未經本公司書面許可，不可部份複製。

This document is issued by the Company subject to its General Conditions of Service printed overleaf, available on request or accessible at <http://www.sgs.com.tw/Terms-and-Conditions> and, for electronic format documents, subject to Terms and Conditions for Electronic Documents at <http://www.sgs.com.tw/Terms-and-Conditions>. Attention is drawn to the limitation of liability, indemnification and jurisdiction issues defined therein. Any holder of this document is advised that information contained hereon reflects the Company's findings at the time of its intervention only and within the limits of client's instruction, if any. The Company's sole responsibility is to its Client and this document does not exonerate parties to a transaction from exercising all their rights and obligations under the transaction documents. This document cannot be reproduced, except in full, without prior written approval of the Company. Any unauthorized alteration, forgery or falsification of the content or appearance of this document is unlawful and offenders may be prosecuted to the fullest extent of the law.

Revision History

Rev.	Issue Date	Revisions	Effect Page	Revised By
00	November 03, 2022	Initial Issue	ALL	Becca Chen
01	December 13, 2022	See the following Note Rev. (01)	P7	Becca Chen

Note

Rev. (01):

1. Modify decision of final test mode and EUT system operation.

TABLE OF CONTENTS

1	TEST RESULT CERTIFICATION	4
2	EUT DESCRIPTION	6
3	TEST METHODOLOGY	7
3.1.	DECISION OF FINAL TEST MODE	7
3.2.	EUT SYSTEM OPERATION	7
4	SETUP OF EQUIPMENT UNDER TEST	8
4.1.	DESCRIPTION OF SUPPORT UNITS	8
4.2.	CONFIGURATION OF SYSTEM UNDER TEST	9
5	FACILITIES AND ACCREDITATIONS	10
5.1.	FACILITIES.....	10
5.2.	ACCREDITATIONS.....	10
5.3.	MEASUREMENT UNCERTAINTY	11
6	CONDUCTED EMISSION MEASUREMENT	12
6.1.	LIMITS OF CONDUCTED EMISSION MEASUREMENT	12
6.2.	TEST INSTRUMENTS.....	12
6.3.	TEST PROCEDURES	13
6.4.	TEST SETUP.....	14
6.5.	DATA SAMPLE:.....	14
6.6.	TEST RESULTS	14
7	RADIATED EMISSION MEASUREMENT	15
7.1.	LIMITS OF RADIATED EMISSION MEASUREMENT	15
7.1.1	Frequency Range	15
7.1.2	Limits of Radiated Emission	16
7.2.	TEST INSTRUMENTS.....	18
7.3.	TEST PROCEDURES	20
7.4.	TEST SETUP.....	22
7.5.	DATA SAMPLE:.....	23
7.6.	TEST RESULTS	24
8	PHOTOGRAPHS OF THE TEST CONFIGURATION	30
	APPENDIX 1 - PHOTOGRAPHS OF EUT	32

1 TEST RESULT CERTIFICATION

Product:	Hand Free Module
Brand:	Continental
Model:	HFM201
Applicant:	Continental Automotive Technologies GmbH Siemensstrasse 12 93055 Regensburg Germany
Manufacturer:	Continental Automotive Technologies GmbH Siemensstrasse 12 93055 Regensburg Germany
Factory:	(1) Continental Automotive Changchun Co., Ltd. Jingyue Branch 5800 Shengtai Street Changchun, 130000 Jilin P.R. China (2) CONTINENTAL AUTOMOTIVE GUADALAJARA MEXICO S DE RL DE CV Camino a la Tijera No. 3 K.m. 3.5 Carretera Guadalajara Morelia. Colonia la Tijera 45640 Tlajomulco de Zúñiga Jalisco, MEXICO
Tested:	October 10, 2022
Test Voltage:	DC 12V

EMISSION			
Standard	Item	Result	Remarks
FCC 47 CFR Part 15 Subpart B, CISPR 22: 2008, ISED ICES-003 Issue 7-2020, ANSI C63.4-2014, ANSI C63.4a 2017	Conducted (Power Port)	N/A	Not applicable, because EUT doesn't connect to AC Main Source direct.
	Radiated	PASS	Meet Class B limit

Note: 1. The statements of test result on the above are decided by the request of test standard only; the measurement uncertainties are not factored into this compliance determination.
 2. The information of measurement uncertainty is available upon the customer's request.

Deviation from Applicable Standard
None

Statements of Conformity
Determination of compliance is based on the results of the compliance measurement, not taking into account measurement instrumentation uncertainty.

The above equipment has been tested by Compliance Certification Services Inc., and found compliance with the requirements set forth in the technical standards mentioned above. The results of testing in this report apply only to the product/system, which was tested. Other similar equipment will not necessarily produce the same results due to production tolerance and measurement uncertainties.

Approved by:

A handwritten signature in black ink that reads 'Alex Chiang'. The signature is written in a cursive style.

Hex Chiang
Asst. Manager

2 EUT DESCRIPTION

Product	Hand Free Module
Brand Name	Continental
Model	HFM201
Applicant	Continental Automotive Technologies GmbH
Housing material	Plastic
Received Date	October 03, 2022
EUT Power Rating	DC 12V
AC Power Cord Type	N/A
DC Power Cord Type	N/A

Note: Client consigns only one sample to test (model number: HFM201). Therefore, the testing Lab. just guarantees the unit, which has been tested.

I/O Port

I/O PORT TYPES	Q'TY	TESTED WITH
1). DC Port	1	1

3 TEST METHODOLOGY

3.1. DECISION OF FINAL TEST MODE

1. The following test mode was scanned during the preliminary test:

Pre-Test Mode
Mode 1: Transmitter Mode (For Car use)

2. After the preliminary scan, the following test mode was found to produce the highest emission level.

Final Test Mode		
Emission	Conducted Emission	N/A
	Radiated Emission	Mode 1

Then, the above highest emission mode of the configuration of the EUT and cable was chosen for all final test items.

3.2. EUT SYSTEM OPERATION

1. Setup the EUT as shown on 4.2.
2. Turn on the power of all equipment.
3. The EUT will Transmitter a combination of modulated Data and Continuous Wave (CW) signals.
4. Setup the condition for test mode and begin the test.

Note: Test program is self-repeating throughout the test.

4 SETUP OF EQUIPMENT UNDER TEST

4.1. DESCRIPTION OF SUPPORT UNITS

The EUT has been tested as an independent unit together with other necessary accessories or support units. The following support units or accessories were used to form a representative test configuration during the tests.

Peripherals Devices:

No.	Equipment	Trade Name	Model No.	Serial No.
1	DC Battery (Remote)	N/A	N/A	N/A

No.	Cable Name	Unit	Shielded	Length	With Core
(A)	DC Cable	1	<input type="checkbox"/> Shielded, <input checked="" type="checkbox"/> Non	1.8 m	<input type="checkbox"/> With Core, <input checked="" type="checkbox"/> Non

Note:

- 1) All the equipment/cables were placed in the worst-case configuration to maximize the emission during the test.
- 2) Grounding was established in accordance with the manufacturer's requirements and conditions for the intended use.

5 FACILITIES AND ACCREDITATIONS

5.1. FACILITIES

All measurement facilities used to collect the measurement data are located at:

- No.11, Wugong 6th Rd., Wugu Dist., New Taipei City, Taiwan.
- No.139, Wugong Rd., Wugu Dist., New Taipei City, Taiwan.

The sites are constructed in conformance with the requirements of ANSI C63.4 and CISPR Publication 22. All receiving equipment conforms to CISPR 16-1-1, CISPR 16-1-2, CISPR 16-1-3, CISPR 16-1-4, CISPR 16-1-5.

5.2. ACCREDITATIONS

Our laboratories are accredited and approved by the following approval agencies according to ISO/IEC 17025.

Taiwan	TAF (TAF 1309)
---------------	----------------

The measuring facility of laboratories has been authorized or registered by the following approval agencies.

Canada	Industry Canada (10M Semi Anechoic Chamber: IC 2324G-1 / IC 2324G-2 / 2324J-1 / 2324J-2 to perform)
Japan	VCCI Radiated emissions: 30 MHz -1000 MHz: R-14343 / Above 1GHz: G-10945 Conducted Test Site No.B: C-13700 / T-11839
USA	FCC (10M Semi Anechoic Chamber (FCC MRA: TW1039) to perform FCC Part 15 measurements)

Copies of granted accreditation certificates are available for downloading from our web site

5.3. MEASUREMENT UNCERTAINTY

Where relevant, the following measurement uncertainty levels have been estimated for tests performed on the EUT as specified in CISPR 16-4-2:

Measurement	Frequency	Uncertainty
Conducted Test Site No.B	0.15MHz ~ 30MHz	±3.06 dB
Radiated emissions (10M Chamber)	30MHz ~ 1GHz	±4.41 dB
	1GHz ~ 6GHz	±4.97 dB
	6GHz ~ 18GHz	±5.13 dB
	18GHz ~ 40GHz	±3.94 dB

This uncertainty represents an expanded uncertainty expressed at approximately the 95% confidence level using a coverage factor of k=2.

Consistent with industry standard determining compliance with the limits shall be base on the results of the compliance measurement. Consequently the measure emissions being less than the maximum allowed emission result in this be a compliant test or passing test.

The listed uncertainties of above table are the worst case values for the entire range of measurement. Please note that the uncertainty values are only provided for informational purpose and aren't used in determining the PASS/FAIL results.

6 CONDUCTED EMISSION MEASUREMENT

6.1. LIMITS OF CONDUCTED EMISSION MEASUREMENT

FCC Part 15 Subpart B/CISPR 22:

FREQUENCY (MHz)	Class A (dBuV)		Class B (dBuV)	
	Quasi - peak	Average	Quasi - peak	Average
0.15 - 0.5	79	66	66 - 56	56 - 46
0.50 – 5.0	73	60	56	46
5.0 – 30.0	73	60	60	50

Note : (1) The lower limit shall apply at the transition frequencies.

(2) The limit decreases linearly with the logarithm of the frequency in the range 0.15 to 0.50 MHz.

(3) All emanation from a class A/B digital device or system, including any network of conductors and apparatus connected there to, shall not exceed the level of field strengths specified above.

ISED ICES-003:

FREQUENCY (MHz)	Class A (dBuV)		Class B (dBuV)	
	Quasi-peak	Average	Quasi-peak	Average
0.15 - 0.5	79	66	66 - 56*	56 - 46*
0.50 – 5.0	73	60	56	46
5.0 – 30.0	73	60	60	50

Note: The more stringent limit applies at transition frequencies.

*. The limit level in dBuV decreases linearly with the logarithm of frequency.

6.2. TEST INSTRUMENTS

Conducted Test Site No.B					
Name of Equipment	Manufacturer	Model	Serial Number	Calibration Date	Calibration Due
N/A					

6.3. TEST PROCEDURES (please refer to measurement standard or CCS SOP PA-031)

Procedure of Preliminary Test

- The EUT and support equipment, if needed, were set up as per the test configuration to simulate typical usage per the user's manual. When the EUT is a tabletop system, a wooden table with a height of 0.8 meters is used and is placed on the ground plane as per ANSI C63.4 (see Test Facility for the dimensions of the ground plane used). When the EUT is a floor standing equipment, it is placed on the ground plane, which has a 12 mm non-conductive covering to insulate the EUT from the ground plane.
- All I/O cables were positioned to simulate typical actual usage as per ANSI C63.4.
- The test equipment EUT installed by AC 120VAC/60Hz main power, through a Line Impedance Stabilization Network (LISN), which was supplied power source and was grounded to the ground plane.
- All support equipment power by from a second LISN.
- The test program of the EUT was started. Emissions were measured on each current carrying line of the EUT using an EMI Test Receiver connected to the LISN powering the EUT.
- The Receiver scanned from 150 kHz to 30MHz for emissions in each of the test modes.
- During the above scans, the emissions were maximized by cable manipulation.
- The test mode(s) described in Item 3.1 were scanned during the preliminary test.
- After the preliminary scan, we found the test mode described in Item 3.1 producing the highest emission level.
- The worst configuration of EUT and cable of the above highest emission level were recorded for reference of the final test.

Procedure of Final Test

- EUT and support equipment were set up on the test bench as per the configuration with highest emission level in the preliminary test.
- A scan was taken on both power lines, Line 1 and Line 2, recording at least the six highest emissions. Emission frequency and amplitude were recorded into a computer in which correction factors were used to calculate the emission level and compare reading to the applicable limit.
- The test data of the worst-case condition(s) was recorded.

6.4. TEST SETUP

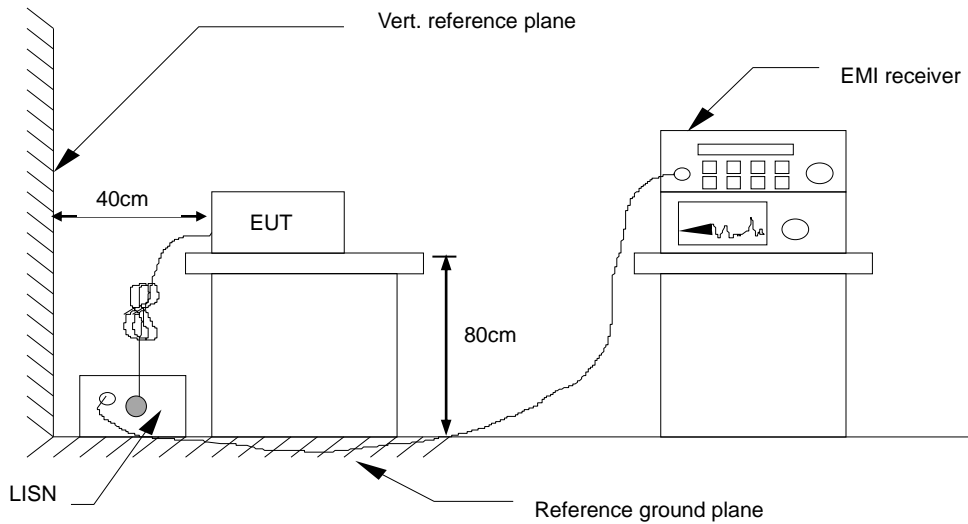

- For the actual test configuration, please refer to the related item – Photographs of the Test Configuration.

6.5. DATA SAMPLE:

Frequency (MHz)	QuasiPeak reading (dBuV)	Average reading (dBuV)	Correction factor (dB)	QuasiPeak result (dBuV)	Average result (dBuV)	QuasiPeak. limit (dBuV)	Average limit (dBuV)	QuasiPeak margin (dB)	Average margin (dB)	Remark
x.xx	43.95	33.00	10.00	53.95	43.00	56.00	46.00	-2.05	-3.00	Pass

Frequency (MHz) = Emission frequency in MHz
 Reading (dBuV) = Uncorrected Analyzer/Receiver reading + Insertion loss of LISN, if it > 0.5 dB
 Correction Factor (dB) = LISN Factor + Cable Loss
 Result (dBuV) = Raw reading converted to dBuV and CF added
 Limit (dBuV) = Limit stated in standard
 Margin (dB) = Result (dBuV) – Limit (dBuV)

6.6. TEST RESULTS

Not applicable, because EUT doesn't connect to AC Main Source direct.

7 RADIATED EMISSION MEASUREMENT

7.1. LIMITS OF RADIATED EMISSION MEASUREMENT

7.1.1 Frequency Range

FCC Part 15 Subpart B:

Highest frequency generated or used in the device or on which the device operates or tunes (MHz)	Upper frequency of measurement range (MHz)
Below 1.75	30
1.75-108	1000
108-500	2000
500-1000	5000
Above 1000	5 th harmonic of the highest frequency or 40GHz, whichever is lower

ISED ICES-003:

Highest internal frequency (F_x)	Highest measurement frequency
$F_x \leq 108$ MHz	1 GHz
108 MHz < $F_x \leq 500$ MHz	2 GHz
500 MHz < $F_x \leq 1$ GHz	5 GHz
$F_x > 1$ GHz	5 x F_x up to a maximum of 40 GHz

Note: F_x is the highest fundamental frequency generated and/or used in the ITE or digital apparatus under test.

7.1.2 Limits of Radiated Emission

FCC Part 15 Subpart B Limit:

- Detector Function : Quasi – Peak

FREQUENCY (MHz)	Class A (at 10m)	Class B (at 3m)
	dBuV/m	dBuV/m
30~88	39	40
88~216	43.5	43.5
216~960	46.4	46
960~1000	49.5	54

- Detector Function : Peak , Average

FREQUENCY (MHz)	Class A (dBuV/m) (at 3m)		Class B (dBuV/m) (at 3m)	
	Peak	Average	Peak	Average
Above 1000	80	60	74	54

CISPR 22 Limit:

- Detector Function : Quasi – Peak

FREQUENCY (MHz)	Class A (at 10m)	Class B (at 10m)
	dBuV/m	dBuV/m
30~230	40	30
230~1000	47	37

NOTE 1 The lower limit shall apply at the transition frequency.

NOTE 2 Additional provisions may be required for cases where interference occurs.

ISED ICES-003 Limit:

- Detector Function : Quasi-peak

Frequency (MHz)	Class A (3 m) (dBuV/m)	Class A (10 m) (dBuV/m)	Class B (3 m) (dBuV/m)	Class B (10 m) (dBuV/m)
30 - 88	50	40	40	30
88 - 216	54	43.5	43.5	33.1
216 - 230	56.9	46.4	46	35.6
230 - 960	57	47	47	37
960 - 1000	60	49.5	54	43.5

Note: The more stringent limit applies at transition frequencies

- Detector Function : Peak, Average

Frequency (MHz)	Class A (3 m) (dBuV/m)		Class B (3 m) (dBuV/m)	
	Peak	Average	Peak	Average
Above 1000	80	60	74	54

7.2. TEST INSTRUMENTS

Below 1GHz

Wugu 10M Chamber					
Name of Equipment	Manufacturer	Model	Serial Number	Calibration Date	Calibration Due
EMI Test Receiver	R&S	ESCI	100961	2022-05-11	2023-05-10
EMI Test Receiver	R&S	ESCI	100962	2022-05-19	2023-05-18
Pre-Amplifier	HP	8447D	2944A08150	2022-04-22	2023-04-21
Pre-Amplifier	HP	8447D	2944A07754	2022-04-22	2023-04-21
Bilog Antenna with 5dB Attenuator	TESEQ	CBL 6112D	31674	2022-02-15	2023-02-14
Bilog Antenna with 5dB Attenuator	TESEQ	CBL 6112D	31675	2022-03-11	2023-03-10
Cable	Huber Suhner	SUCOFLEX 104PEA	33948/4PEA	2022-04-22	2023-04-21
Cable	Huber Suhner	SUCOFLEX 104PEA	33949/4PEA	2022-04-22	2023-04-21
Cable	Huber Suhner	SUCOFLEX 104PEA	330029	2022-04-22	2023-04-21
Cable	Huber Suhner	SUCOFLEX 104PEA	24813	2022-04-22	2023-04-21
Turn Table	CCS	CC-T-1F	N/A	N.C.R	N.C.R
Controller	CCS	CC-C-1F	N/A	N.C.R	N.C.R
Antenna Tower	CCS	CC-A-1F	N/A	N.C.R	N.C.R
AC power source	APE	AFC-130	991259	N.C.R	N.C.R
Software	EZ-EMC (CCS-3A1RE)				

Note:

1. The calibration interval of the above test instruments is 12 months and the calibrations are traceable to NML/ROC and NIST/USA.
2. N.C.R. = No Calibration Required.

Above 1GHz

Wugu 10M Chamber					
Name of Equipment	Manufacturer	Model	Serial Number	Calibration Date	Calibration Due
Horn Antenna	EMCO	3117	00055167	2021-11-25	2022-11-24
Horn Antenna	ETS LINDGREN	3116	00026370	2021-11-30	2022-11-29
Spectrum Analyzer	Agilent	E4446A	MY48250297	2022-08-03	2023-08-02
Pre-Amplifier	EMCI	EMC051845	980040	2022-04-22	2023-04-21
Cable	Huber Suhner	SUCOFLEX 104PEA	33945	2022-04-22	2023-04-21
Cable	Huber Suhner	SUCOFLEX 104PEA	329383	2022-04-22	2023-04-21
Pre-Amplifier	MITEQ	AMF-6F-18004000- 37-8P	985646	2022-09-07	2023-09-06
Band Reject Filter	MICRO TRONICS	BRM 50702	112	2021-11-23	2022-11-22
Turn Table	CCS	CC-T-1F	N/A	N.C.R	N.C.R
Antenna Tower	Sunol Sciences	TLT2	031010-5	N.C.R	N.C.R
Controller	Sunol Sciences	SC104V	031010-1	N.C.R	N.C.R
AC power source	APE	AFC-130	991259	N.C.R	N.C.R
Software	EZ-EMC (CCS-3A1RE)				

Note:

1. The calibration interval of the above test instruments is 12 months and the calibrations are traceable to NML/ROC and NIST/USA.
2. N.C.R. = No Calibration Required.

7.3. TEST PROCEDURES (please refer to measurement standard or CCS SOP PA-031)

The basic test procedure was in accordance with ANSI C63.4-2014 and ICES-003-2020.

Frequency range 30MHz ~ 1GHz

1. The EUT was placed on the top of a rotating table 0.8 meters above the ground at a 10 meter semi-anechoic chamber room. The table was rotated 360 degrees to determine the position.
2. The EUT was set 10 meters away from the interference-receiving antenna, which was mounted on the top of a variable-height antenna tower.
3. The height of antenna is varied from one meter to four meter above the ground to determine the maximum value of the field strength. Both horizontal and vertical polarizations of the antenna are set to make the measurement.
4. For each suspected emission, the EUT was arranged to its worst case and then the antenna was turned to heights for 1 meter to 4 meters and the turn table was turned from 0 degrees to 360 degrees to find the maximum reading.
5. The test-receiver system was set to quasi-peak detect function and specified bandwidth with maximum hold mode when the test frequency is below 1GHz.

NOTE: The resolution bandwidth of test receiver/spectrum analyzer is 120 kHz for Quasi-peak detection (QP) at frequency below 1GHz.

Frequency range above 1GHz

1. The EUT was placed on the top of a rotating table 0.8 meters above the ground at a 3 meter semi-anechoic chamber room. The table was rotated 360 degrees to determine the position.
2. The EUT was set 3 meters away from the directional antenna, which was pointed towards the source of the emission within the EUT. This could be done by either pointing the antenna at an angle towards the source of the emission, or by rotating the EUT, in both height and polarization, to maximize the measured emission.
3. The height of antenna can be varied from one meter to four meters, the height of adjustment depends on the EUT height and the antenna 3 dB beam width both, to detect the maximum value of the field strength. Both horizontal and vertical polarizations of the antenna are set to make the measurement.
4. For each suspected emission, the EUT was arranged to its worst case and then the antenna was turned to heights and the rotatable table was turned from 0 degrees to 360 degrees to find the maximum reading.
5. The test-receiver system was set to peak and average detect function and specified bandwidth with maximum hold mode when the test frequency is above 1GHz.

NOTE:

1. The resolution bandwidth is 1MHz and video bandwidth of test spectrum analyzer is 1 MHz for peak detection at above 1GHz. The resolution bandwidth is 1MHz and video bandwidth of test spectrum analyzer is 100Hz for average detection at frequency above 1 GHz.
2. For measurement of frequency above 1GHz, the EUT was set 3 meters away from the directional antenna.

7.4. TEST SETUP

Below 1GHz

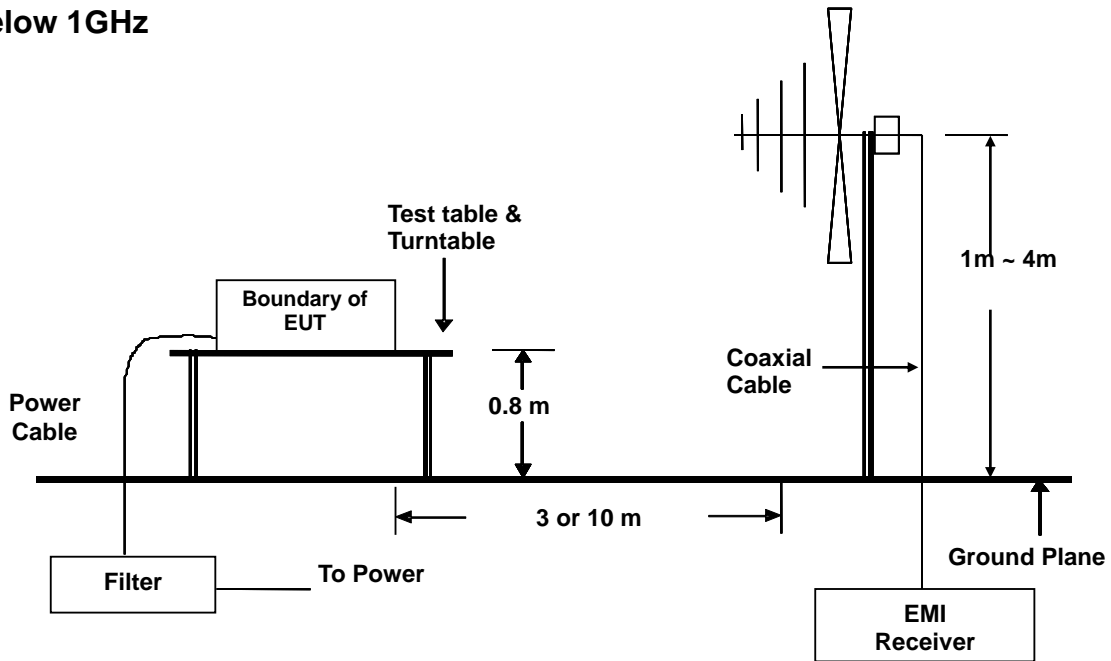

Above 1GHz

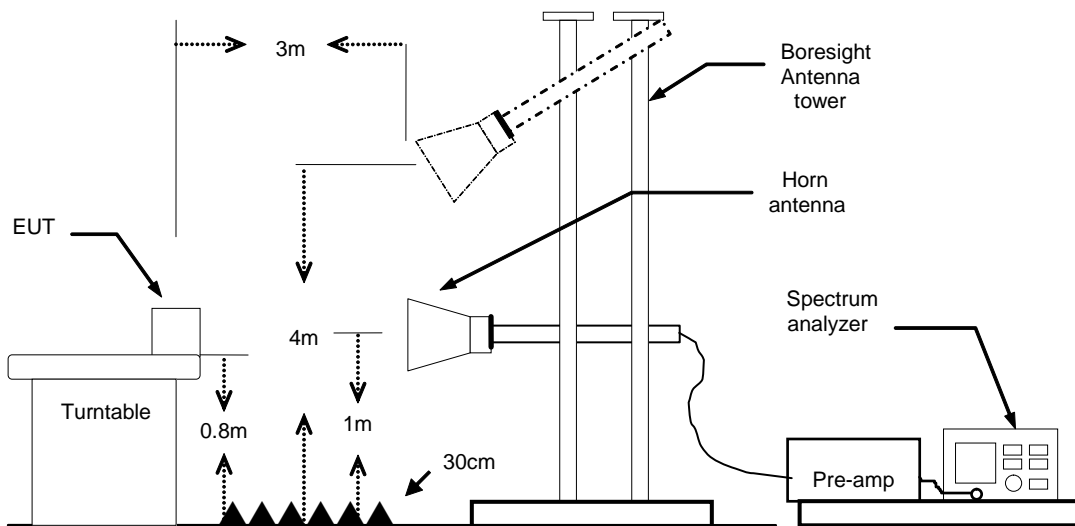

- For the actual test configuration, please refer to the related item – Photographs of the Test Configuration.

7.5. DATA SAMPLE:

Below 1GHz

Frequency (MHz)	Reading (dBuV)	Correction Factor (dB/m)	Result (dBuV/m)	Limit (dBuV/m)	Margin (dB)	Height (cm)	Degree (°)	Remark
xx.xx	16.49	9.86	26.35	30.00	-3.65	116.00	101.00	QP

Above 1GHz

Frequency (MHz)	Reading (dBuV)	Correction Factor (dB/m)	Result (dBuV/m)	Limit (dBuV/m)	Margin (dB)	Height (cm)	Degree (°)	Remark
xx.xx	60.80	-14.59	46.21	74.00	-27.79	200	351	peak
xx.xx	52.05	-13.17	38.88	54.00	-15.12	200	135	AVG

Frequency (MHz) = Emission frequency in MHz
 Reading (dBuV) = Uncorrected Analyzer / Receiver reading
 Correction Factor (dB/m) = Antenna factor + Cable loss – Amplifier gain
 Result (dBuV/m) = Reading (dBuV) + Corr. Factor (dB/m)
 Limit (dBuV/m) = Limit stated in standard
 Margin (dB) = Result (dBuV/m) – Limit (dBuV/m)
 Q.P. = Quasi-Peak

7.6. TEST RESULTS

Below 1GHz

Model No.	HFM201	Test Mode	Mode 1
Environmental Conditions	23°C, 55% RH	Tested Date	2022/10/10
Antenna Pole	Vertical	Antenna Distance	10m
Detector Function	Quasi-peak.	Tested By	Rex Kuo
6dB Bandwidth	120 kHz	Standard	FCC Part 15 Subpart B

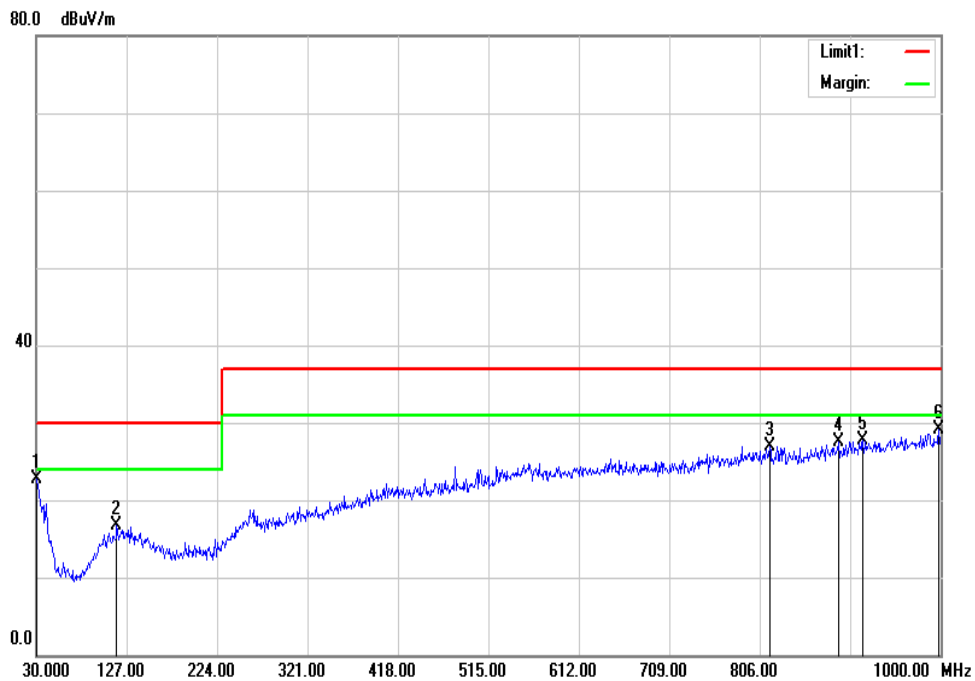

No.	Frequency (MHz)	Reading (dBuV)	Correction Factor (dB/m)	Result (dBuV/m)	Limit (dBuV/m)	Margin (dB)	Height (cm)	Degree (°)	Remark
1	30.9700	25.79	-3.18	22.61	30.00	-7.39	399	119	QP
2	116.3300	24.72	-8.10	16.62	30.00	-13.38	399	4	QP
3	816.6700	23.05	3.92	26.97	37.00	-10.03	261	0	QP
4	890.3900	22.62	4.86	27.48	37.00	-9.52	300	0	QP
5	916.5800	22.43	5.24	27.67	37.00	-9.33	135	360	QP
6	998.0600	22.36	6.65	29.01	37.00	-7.99	399	359	QP

Note: The other emission levels were very low against the limit.

Model No.	HFM201	Test Mode	Mode 1
Environmental Conditions	23°C, 55% RH	Tested Date	2022/10/10
Antenna Pole	Horizontal	Antenna Distance	10m
Detector Function	Quasi-peak.	Rex Kuo	Rex Kuo
6dB Bandwidth	120 kHz	Standard	FCC Part 15 Subpart B

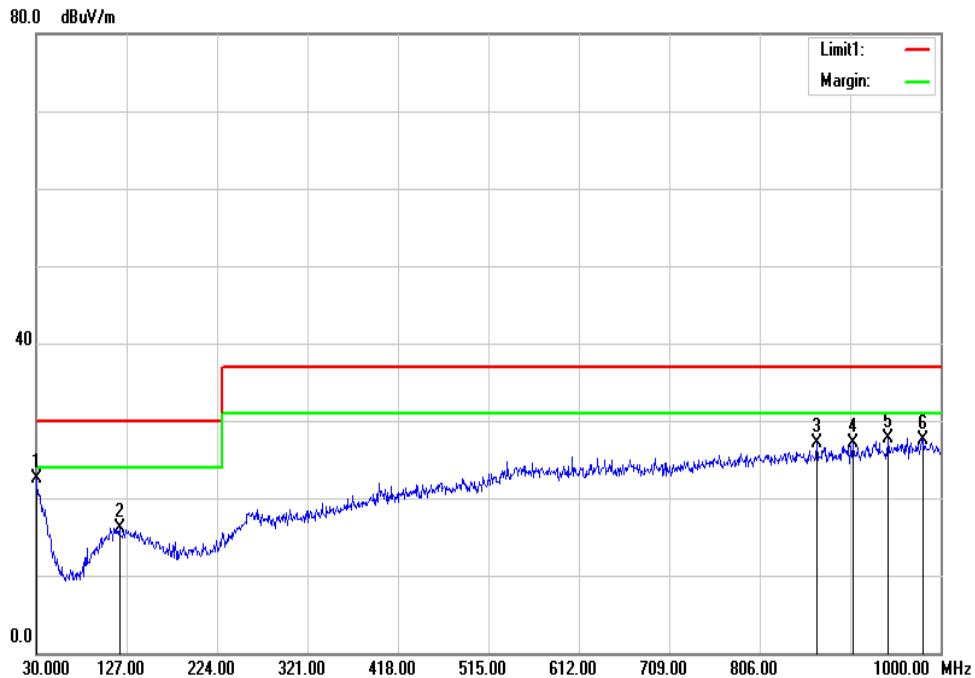

No.	Frequency (MHz)	Reading (dBuV)	Correction Factor (dB/m)	Result (dBuV/m)	Limit (dBuV/m)	Margin (dB)	Height (cm)	Degree (°)	Remark
1	30.0000	25.86	-3.35	22.51	30.00	-7.49	399	360	QP
2	119.2400	24.95	-8.81	16.14	30.00	-13.86	300	181	QP
3	867.1100	24.71	2.47	27.18	37.00	-9.82	100	235	QP
4	905.9100	24.17	3.00	27.17	37.00	-9.83	399	163	QP
5	943.7400	24.33	3.46	27.79	37.00	-9.21	246	0	QP
6	981.5700	23.58	3.93	27.51	37.00	-9.49	364	360	QP

Note: The other emission levels were very low against the limit.

Model No.	HFM201	Test Mode	Mode 1
Environmental Conditions	23°C, 55% RH	Tested Date	2022/10/10
Antenna Pole	Vertical	Antenna Distance	10m
Detector Function	Quasi-peak.	Tested By	Rex Kuo
6dB Bandwidth	120 kHz	Standard	ISED ICES-003 Issue 7

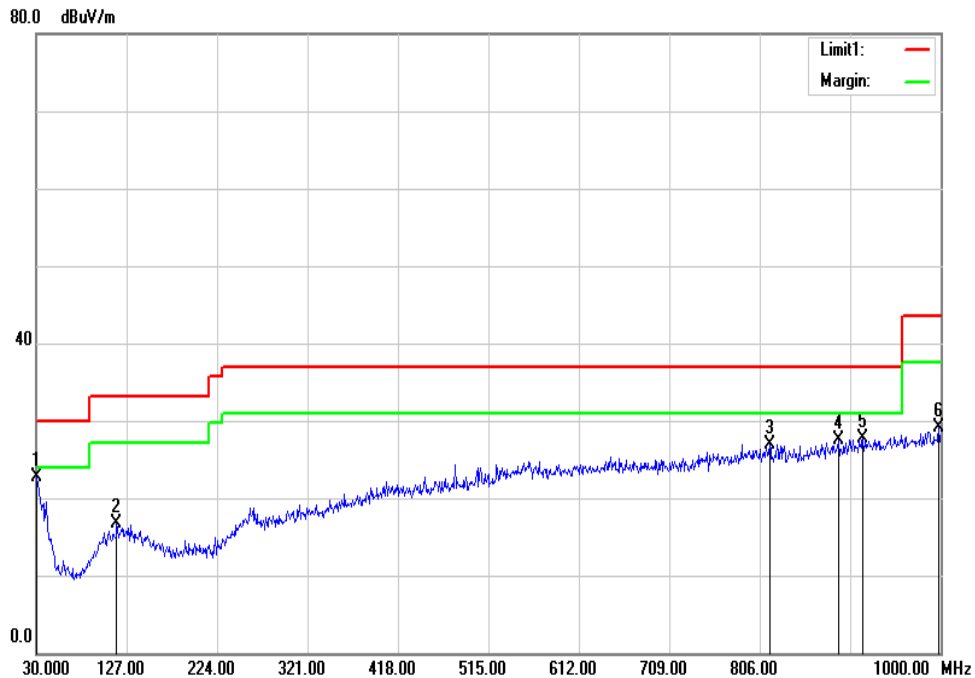

No.	Frequency (MHz)	Reading (dBuV)	Correction Factor (dB/m)	Result (dBuV/m)	Limit (dBuV/m)	Margin (dB)	Height (cm)	Degree (°)	Remark
1	30.9700	25.79	-3.18	22.61	30.00	-7.39	399	119	QP
2	116.3300	24.72	-8.10	16.62	33.10	-16.48	399	4	QP
3	816.6700	23.05	3.92	26.97	37.00	-10.03	261	0	QP
4	890.3900	22.62	4.86	27.48	37.00	-9.52	300	0	QP
5	916.5800	22.43	5.24	27.67	37.00	-9.33	135	360	QP
6	998.0600	22.36	6.65	29.01	43.50	-14.49	399	359	QP

Note: The other emission levels were very low against the limit.

Model No.	HFM201	Test Mode	Mode 1
Environmental Conditions	23°C, 55% RH	Tested Date	2022/10/10
Antenna Pole	Horizontal	Antenna Distance	10m
Detector Function	Quasi-peak.	Tested By	Rex Kuo
6dB Bandwidth	120 kHz	Standard	ISED ICES-003 Issue 7

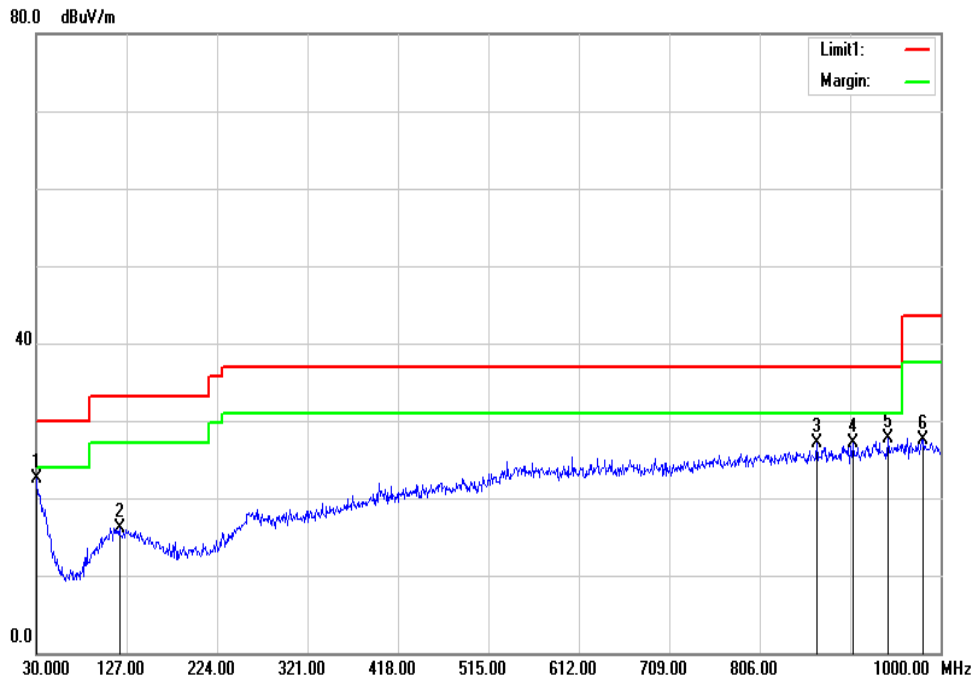

No.	Frequency (MHz)	Reading (dBuV)	Correction Factor (dB/m)	Result (dBuV/m)	Limit (dBuV/m)	Margin (dB)	Height (cm)	Degree (°)	Remark
1	30.0000	25.86	-3.35	22.51	30.00	-7.49	399	360	QP
2	119.2400	24.95	-8.81	16.14	33.10	-16.96	300	181	QP
3	867.1100	24.71	2.47	27.18	37.00	-9.82	100	235	QP
4	905.9100	24.17	3.00	27.17	37.00	-9.83	399	163	QP
5	943.7400	24.33	3.46	27.79	37.00	-9.21	246	0	QP
6	981.5700	23.58	3.93	27.51	43.50	-15.99	364	360	QP

Note: The other emission levels were very low against the limit.

Above 1GHz

Model No.	HFM201	Test Mode	Mode 1
Environmental Conditions	23°C, 55% RH	Tested Date	2022/10/10
Antenna Pole	Vertical	Antenna Distance	3m
Highest frequency generated or used	433.92MHz	Upper frequency	2GHz
Detector Function	Peak	Tested By	Rex Kuo
6dB Bandwidth	1 MHz		

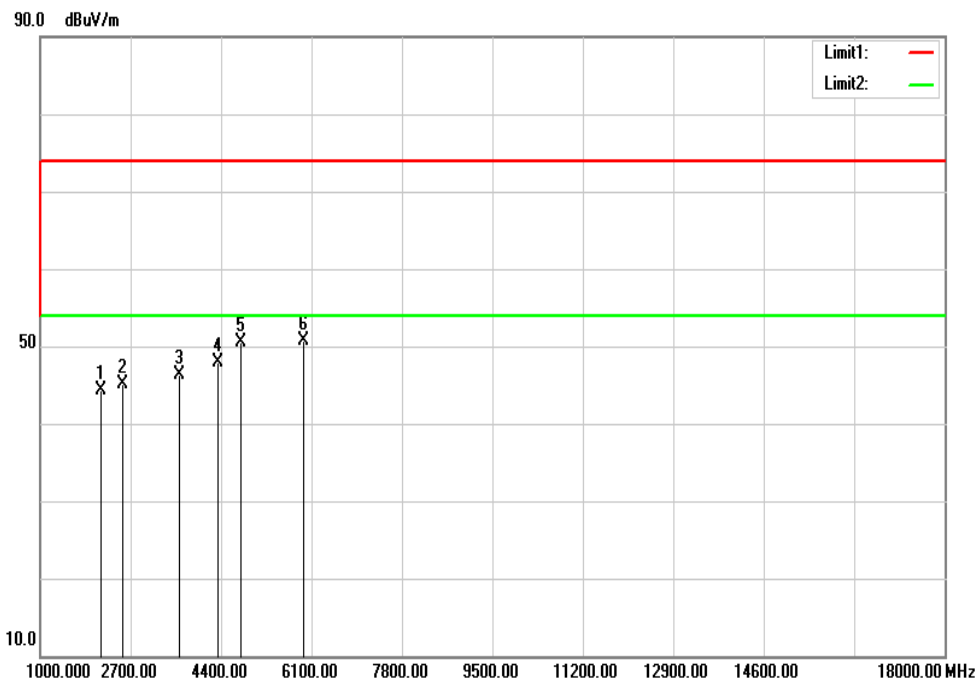

No.	Frequency (MHz)	Reading (dBuV)	Correction Factor (dB/m)	Result (dBuV/m)	Limit (dBuV/m)	Margin (dB)	Height (cm)	Degree (°)	Remark
1	2130.500	57.83	-13.43	44.40	74.00	-29.60	200	233	peak
2	2547.000	58.05	-13.02	45.03	74.00	-28.97	197	0	peak
3	3609.500	57.11	-10.76	46.35	74.00	-27.65	200	0	peak
4	4349.000	56.82	-8.88	47.94	74.00	-26.06	400	121	peak
5	4774.000	58.10	-7.57	50.53	74.00	-23.47	286	360	peak
6	5947.000	56.05	-5.38	50.67	74.00	-23.33	300	359	peak

REMARKS:

1. The other emission levels were very low against the limit.
2. Margin (dB) = Result (dBuV/m) – Limit (dBuV/m)

Model No.	HFM201	Test Mode	Mode 1
Environmental Conditions	23°C, 55% RH	Tested Date	2022/10/10
Antenna Pole	Horizontal	Antenna Distance	3m
Highest frequency generated or used	433.92MHz	Upper frequency	2GHz
Detector Function	Peak	Tested By	Rex Kuo
6dB Bandwidth	1 MHz		

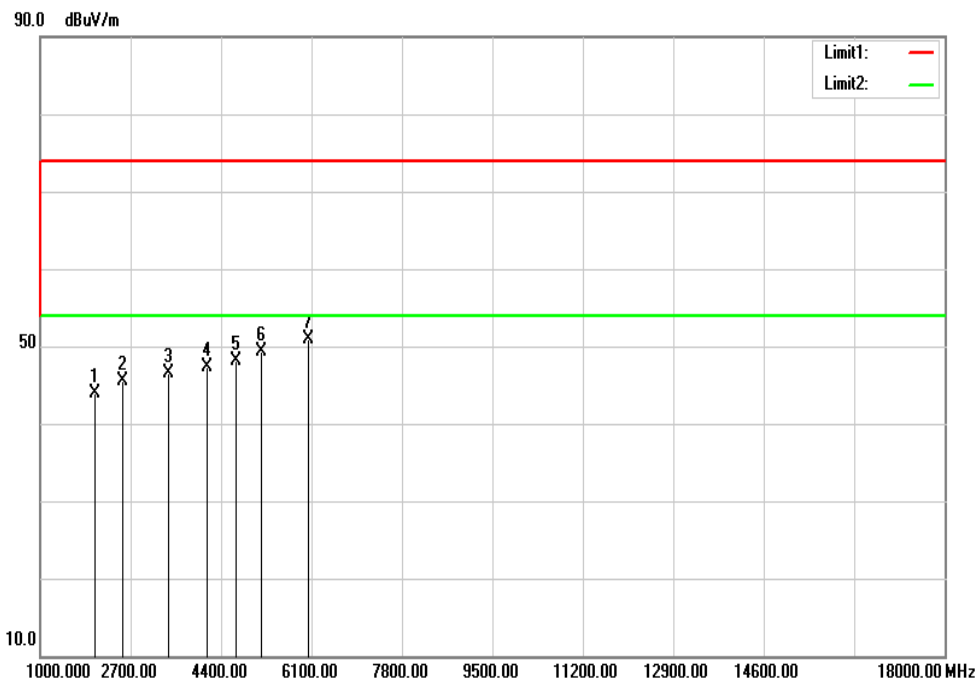

No.	Frequency (MHz)	Reading (dBuV)	Correction Factor (dB/m)	Result (dBuV/m)	Limit (dBuV/m)	Margin (dB)	Height (cm)	Degree (°)	Remark
1	2037.000	57.47	-13.62	43.85	74.00	-30.15	100	112	peak
2	2547.000	58.45	-13.02	45.43	74.00	-28.57	300	121	peak
3	3422.500	58.06	-11.54	46.52	74.00	-27.48	204	0	peak
4	4145.000	57.31	-10.02	47.29	74.00	-26.71	400	321	peak
5	4680.500	55.69	-7.50	48.19	74.00	-25.81	300	139	peak
6	5156.500	56.33	-7.12	49.21	74.00	-24.79	200	350	peak
7	6057.500	56.10	-5.26	50.84	74.00	-23.16	300	359	peak

REMARKS:

1. The other emission levels were very low against the limit.
2. Margin (dB) = Result (dBuV/m) – Limit (dBuV/m)