

FCC Measurement/Technical Report on CMBTRX1

FCC ID: KR5CMBTRX1
IC: 7812D-CMBTRX1

Test Report Reference: MDE_CONTI_2135_FCC_02

Test Laboratory:

7layers GmbH
Borsigstrasse 11
40880 Ratingen
Germany



Deutsche
Akkreditierungsstelle
D-PL-12140-01-01
D-PL-12140-01-02
D-PL-12140-01-03

Note:

The following test results relate only to the devices specified in this document. This report shall not be reproduced in parts without the written approval of the test laboratory.

7layers GmbH
Borsigstraße 11
40880 Ratingen, Germany
T +49 (0) 2102 749 0
F +49 (0) 2102 749 350

Geschäftsführer/
Managing Directors:
Frank Spiller
Bernhard Retka
Alexandre Norré-Oudard

Registergericht/registered:
Düsseldorf HRB 75554
USt-Id.-Nr./VAT-No. DE203159652
Steuer-Nr./TAX-No. 147/5869/0385

*a Bureau Veritas
Group Company*

www.7layers.com

Table of Contents

1.1	Applied Standards	3
1.2	FCC-IC Correlation Table	4
1.3	Measurement Summary / Signatures	5
2	Administrative Data	9
2.1	Testing Laboratory	9
2.2	Project Data	9
2.3	Applicant Data	9
2.4	Manufacturer Data	9
3	Test object Data	10
3.1	General EUT Description	10
3.2	EUT Main components	11
3.3	Ancillary Equipment	12
3.4	Auxiliary Equipment	12
3.5	EUT Setups	12
3.6	Operating Modes	13
3.7	Product labelling	13
4	Test Results	14
4.1	-10 dB BANDWIDTH – 15.503(d)	14
4.2	PEAK EMISSION – 15.521(e)	19
4.3	Radiated Emissions	24
4.4	Radiated Emissions in GNSS bands	42
5	Test Equipment	47
6	Antenna Factors, Cable Loss and Sample Calculations	49
6.1	LISN R&S ESH3-Z5 (150 kHz – 30 MHz)	49
6.2	Antenna R&S HFH2-Z2 (9 kHz – 30 MHz)	50
6.3	Antenna R&S HL562 (30 MHz – 1 GHz)	51
6.4	Antenna R&S HF907 (1 GHz – 18 GHz)	52
6.5	Antenna EMCO 3160-09 (18 GHz – 26.5 GHz)	53
6.6	Antenna EMCO 3160-10 (26.5 GHz – 40 GHz)	54
7	Setup Drawings	55
8	Measurement Uncertainties	56
9	Photo Report	57

Applied Standards and Test Summary

1.1 APPLIED STANDARDS

Applicable FCC Rules

Prepared in accordance with the requirements of FCC Rules and Regulations as listed in 47 CFR Ch.1 Parts 2 and 15 (10-1-20 Edition). The following subparts are applicable to the results in this test report.

Part 2, Subpart J - Equipment Authorization Procedures, Certification

Part 15, Subpart F – Ultra Wideband Operation

- § 15.201 Equipment authorization requirement
- § 15.207 Conducted limits
- § 15.209 Radiated emission limits; general requirements
- § 15.503 Definitions
- § 15.519 Technical Requirements for hand held UWB devices
- § 15.521 Technical requirements applicable for all UWB devices

Note:
ANSI C63.10–2013 is applied.

Summary Test Results:

The EUT complied with all performed tests as listed in chapter 1.3 Measurement Summary / Signatures.

1.2 FCC-IC CORRELATION TABLE

**Correlation of measurement requirements for
handheld UWB equipment
from
FCC and IC**

Measurement	FCC reference	IC reference
Conducted emissions on AC Mains	§ 15.207	RSS-Gen Issue 5: 8.8
-10 dB Occupied bandwidth	§ 15.503 (d); § 15.519 (b)	RSS-220 Issue 1: 2; RSS-220 Issue 1: 5.1 (a); RSS-220 Issue 1: Annex 2
Peak Emission	§ 15.519 (e); § 15.521 (e)	RSS-220 Issue 1: 5.3.1 (g) RSS-220 Issue 1: Annex 4
Transmitter spurious radiated emissions	§ 15.209 (a); § 15.519 (c);	RSS-220 Issue 1: 3.4; RSS-220 Issue 1: 5.3.1 (c), (d)
Transmitter spurious radiated emissions GNSS bands	§ 15.519 (d)	RSS-220 Issue 1: 5.3.1 (e)
Transmission time	§ 15.519 (a) (1)	RSS-220 Issue 1: 5.3.1 (b)

1.3 MEASUREMENT SUMMARY / SIGNATURES

47 CFR CHAPTER I FCC PART 15 Subpart F § 15.207

Conducted Emissions at AC mains

The measurement was performed according to ANSI C63.10, chapter 6.2

Final Result

OP-Mode	Setup	FCC	IC
AC mains connection, Test setup -, -	-	N/A	N/A

47 CFR CHAPTER I FCC PART 15 Subpart F § 15.503 (d)

-10 dB Occupied Bandwidth

The measurement was performed according to ANSI C63.10, chapter 10.1

Final Result

OP-Mode	Setup	FCC	IC
Measurement method, Operating band, Channel, OP-Mode			
radiated, 3100-10600 MHz, CH_5_ANT1, OP-Mode 1	S01_AD01	Passed	Passed
radiated, 3100-10600 MHz, CH_5_ANT2, OP-Mode 1	S01_AD01	Passed	Passed
radiated, 3100-10600 MHz, CH_5_ANT1, OP-Mode 2	S01_AD01	Passed	Passed
radiated, 3100-10600 MHz, CH_5_ANT2, OP-Mode 2	S01_AD01	Passed	Passed
radiated, 3100-10600 MHz, CH_5_ANT1, OP-Mode 3	S01_AD01	Passed	Passed
radiated, 3100-10600 MHz, CH_5_ANT2, OP-Mode 3	S01_AD01	Passed	Passed
radiated, 3100-10600 MHz, CH_5_ANT1, OP-Mode 4	S01_AD01	Passed	Passed
radiated, 3100-10600 MHz, CH_5_ANT2, OP-Mode 4	S01_AD01	Passed	Passed
radiated, 3100-10600 MHz, CH_6_ANT1, OP-Mode 1	S01_AD01	Passed	Passed
radiated, 3100-10600 MHz, CH_6_ANT2, OP-Mode 1	S01_AD01	Passed	Passed
radiated, 3100-10600 MHz, CH_6_ANT1, OP-Mode 4	S01_AD01	Passed	Passed
radiated, 3100-10600 MHz, CH_6_ANT2, OP-Mode 4	S01_AD01	Passed	Passed
radiated, 3100-10600 MHz, CH_8_ANT1, OP-Mode 1	S01_AD01	Passed	Passed
radiated, 3100-10600 MHz, CH_8_ANT2, OP-Mode 1	S01_AD01	Passed	Passed
radiated, 3100-10600 MHz, CH_8_ANT1, OP-Mode 4	S01_AD01	Passed	Passed
radiated, 3100-10600 MHz, CH_8_ANT2, OP-Mode 4	S01_AD01	Passed	Passed
radiated, 3100-10600 MHz, CH_9_ANT1, OP-Mode 1	S01_AD01	Passed	Passed
radiated, 3100-10600 MHz, CH_9_ANT2, OP-Mode 1	S01_AD01	Passed	Passed
radiated, 3100-10600 MHz, CH_9_ANT1, OP-Mode 2	S01_AD01	Passed	Passed
radiated, 3100-10600 MHz, CH_9_ANT2, OP-Mode 2	S01_AD01	Passed	Passed
radiated, 3100-10600 MHz, CH_9_ANT1, OP-Mode 3	S01_AD01	Passed	Passed
radiated, 3100-10600 MHz, CH_9_ANT2, OP-Mode 3	S01_AD01	Passed	Passed
radiated, 3100-10600 MHz, CH_9_ANT1, OP-Mode 4	S01_AD01	Passed	Passed
radiated, 3100-10600 MHz, CH_9_ANT2, OP-Mode 4	S01_AD01	Passed	Passed

47 CFR CHAPTER I FCC PART 15 Subpart F

§ 15.521 (e)

Peak Emission

The measurement was performed according to ANSI C63.10, chapter 10.3.5, 10.3.6

Final Result

OP-Mode

Measurement method, Operating band, Channel, OP-Mode

	Setup	FCC	IC
radiated, 3100-10600 MHz, CH_5_ANT1, OP-Mode 1	S01_AD01	Passed	Passed
radiated, 3100-10600 MHz, CH_5_ANT2, OP-Mode 1	S01_AD01	Passed	Passed
radiated, 3100-10600 MHz, CH_5_ANT1, OP-Mode 2	S01_AD01	Passed	Passed
radiated, 3100-10600 MHz, CH_5_ANT2, OP-Mode 2	S01_AD01	Passed	Passed
radiated, 3100-10600 MHz, CH_5_ANT1, OP-Mode 3	S01_AD01	Passed	Passed
radiated, 3100-10600 MHz, CH_5_ANT2, OP-Mode 3	S01_AD01	Passed	Passed
radiated, 3100-10600 MHz, CH_5_ANT1, OP-Mode 4	S01_AD01	Passed	Passed
radiated, 3100-10600 MHz, CH_5_ANT2, OP-Mode 4	S01_AD01	Passed	Passed
radiated, 3100-10600 MHz, CH_6_ANT1, OP-Mode 1	S01_AD01	Passed	Passed
radiated, 3100-10600 MHz, CH_6_ANT2, OP-Mode 1	S01_AD01	Passed	Passed
radiated, 3100-10600 MHz, CH_6_ANT1, OP-Mode 4	S01_AD01	Passed	Passed
radiated, 3100-10600 MHz, CH_6_ANT2, OP-Mode 4	S01_AD01	Passed	Passed
radiated, 3100-10600 MHz, CH_8_ANT1, OP-Mode 1	S01_AD01	Passed	Passed
radiated, 3100-10600 MHz, CH_8_ANT2, OP-Mode 1	S01_AD01	Passed	Passed
radiated, 3100-10600 MHz, CH_8_ANT1, OP-Mode 4	S01_AD01	Passed	Passed
radiated, 3100-10600 MHz, CH_8_ANT2, OP-Mode 4	S01_AD01	Passed	Passed
radiated, 3100-10600 MHz, CH_9_ANT1, OP-Mode 1	S01_AD01	Passed	Passed
radiated, 3100-10600 MHz, CH_9_ANT2, OP-Mode 1	S01_AD01	Passed	Passed
radiated, 3100-10600 MHz, CH_9_ANT1, OP-Mode 2	S01_AD01	Passed	Passed
radiated, 3100-10600 MHz, CH_9_ANT2, OP-Mode 2	S01_AD01	Passed	Passed
radiated, 3100-10600 MHz, CH_9_ANT1, OP-Mode 3	S01_AD01	Passed	Passed
radiated, 3100-10600 MHz, CH_9_ANT2, OP-Mode 3	S01_AD01	Passed	Passed
radiated, 3100-10600 MHz, CH_9_ANT1, OP-Mode 4	S01_AD01	Passed	Passed
radiated, 3100-10600 MHz, CH_9_ANT2, OP-Mode 4	S01_AD01	Passed	Passed

47 CFR CHAPTER I FCC PART 15 Subpart F

§ 15.209 (a) / § 15.519 (c)

Radiated Emissions

The measurement was performed according to ANSI C63.10, chapter 10.2, 10.3

Final Result

OP-Mode

Measurement method, Operating band, Measurement range, Channel, OP-Mode

Setup

FCC

IC

radiated, 3100-10600 MHz, 9 kHz – 30 MHz, CH5_ANT1, OP-Mode 3	S01_AD01	Passed	Passed
radiated, 3100-10600 MHz, 30 MHz – 960 MHz, CH5_ANT1, OP-Mode 3	S01_AD01	Passed	Passed
radiated, 3100-10600 MHz, 960 MHz – 12.4 GHz, CH5_ANT1, OP-Mode 3	S01_AD01	Passed	Passed
radiated, 3100-10600 MHz, 12.4 GHz – 18 GHz, CH5_ANT1, OP-Mode 3	S01_AD01	Passed	Passed
radiated, 3100-10600 MHz, 18 GHz – 26 GHz, CH5_ANT1, OP-Mode 3	S01_AD01	Passed	Passed
radiated, 3100-10600 MHz, 26 GHz – 40 GHz, CH5_ANT1, OP-Mode 3	S01_AD01	Passed	Passed
radiated, 3100-10600 MHz, 9 kHz – 30 MHz, CH6_ANT2, OP-Mode 4	S01_AD01	Passed	Passed
radiated, 3100-10600 MHz, 30 MHz – 960 MHz, CH6_ANT2, OP-Mode 4	S01_AD01	Passed	Passed
radiated, 3100-10600 MHz, 960 MHz – 12.4 GHz, CH6_ANT2, OP-Mode 4	S01_AD01	Passed	Passed
radiated, 3100-10600 MHz, 12.4 GHz – 18 GHz, CH6_ANT2, OP-Mode 4	S01_AD01	Passed	Passed
radiated, 3100-10600 MHz, 18 GHz – 26 GHz, CH6_ANT2, OP-Mode 4	S01_AD01	Passed	Passed
radiated, 3100-10600 MHz, 26 GHz – 40 GHz, CH6_ANT2, OP-Mode 4	S01_AD01	Passed	Passed
radiated, 3100-10600 MHz, 9 kHz – 30 MHz, CH8_ANT2, OP-Mode 4	S01_AD01	Passed	Passed
radiated, 3100-10600 MHz, 30 MHz – 960 MHz, CH8_ANT2, OP-Mode 4	S01_AD01	Passed	Passed
radiated, 3100-10600 MHz, 960 MHz – 12.4 GHz, CH8_ANT2, OP-Mode 4	S01_AD01	Passed	Passed
radiated, 3100-10600 MHz, 12.4 GHz – 18 GHz, CH8_ANT2, OP-Mode 4	S01_AD01	Passed	Passed
radiated, 3100-10600 MHz, 18 GHz – 26 GHz, CH8_ANT2, OP-Mode 4	S01_AD01	Passed	Passed
radiated, 3100-10600 MHz, 26 GHz – 40 GHz, CH8_ANT2, OP-Mode 4	S01_AD01	Passed	Passed
radiated, 3100-10600 MHz, 9 kHz – 30 MHz, CH9_ANT2, OP-Mode 3	S01_AD01	Passed	Passed
radiated, 3100-10600 MHz, 30 MHz – 960 MHz, CH9_ANT2, OP-Mode 3	S01_AD01	Passed	Passed
radiated, 3100-10600 MHz, 960 MHz – 12.4 GHz, CH9_ANT2, OP-Mode 3	S01_AD01	Passed	Passed
radiated, 3100-10600 MHz, 12.4 GHz – 18 GHz, CH9_ANT2, OP-Mode 3	S01_AD01	Passed	Passed
radiated, 3100-10600 MHz, 18 GHz – 26 GHz, CH9_ANT2, OP-Mode 3	S01_AD01	Passed	Passed
radiated, 3100-10600 MHz, 26 GHz – 40 GHz, CH9_ANT2, OP-Mode 3	S01_AD01	Passed	Passed

47 CFR CHAPTER I FCC PART 15 Subpart F

§ 15.519 (d)

Radiated Emissions in GNSS bands

The measurement was performed according to ANSI C63.10, chapter 10.3.10

Final Result

OP-Mode

Measurement method, Operating band, Measurement range, Channel, OP-Mode

Setup

FCC

IC

radiated, 3100-10600 MHz, 1164 MHz – 1240 MHz, CH5_ANT1, OP-Mode 3	S01_AD01	Passed	Passed
radiated, 3100-10600 MHz, 1164 MHz – 1240 MHz, CH6_ANT2, OP-Mode 4	S01_AD01	Passed	Passed
radiated, 3100-10600 MHz, 1164 MHz – 1240 MHz, CH8_ANT2, OP-Mode 4	S01_AD01	Passed	Passed
radiated, 3100-10600 MHz, 1559 MHz – 1610 MHz, CH9_ANT2, OP-Mode 3	S01_AD01	Passed	Passed

N/A: Not applicable

N/P: Not performed

Revision History

Report version control			
Version	Release date	Change Description	Version validity
initial	2022-03-10	--	valid



(responsible for accreditation scope)
Dipl.-Ing. Marco Kullik

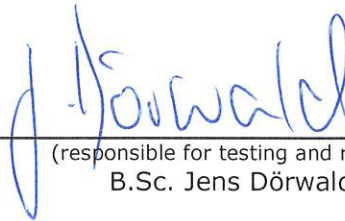

(responsible for testing and report)
B.Sc. Jens Dörwald



7 layers GmbH, Borsigstr. 11
40880 Ratingen, Germany
Phone +49 (0)2102 749 0

2 ADMINISTRATIVE DATA

2.1 TESTING LABORATORY

Company Name: 7layers GmbH
Address: Borsigstr. 11
40880 Ratingen
Germany

The test facility is accredited by the following accreditation organisation:

Laboratory accreditation no: DAKKS D-PL-12140-01-01| -02 | -03
FCC Designation Number: DE0015
FCC Test Firm Registration: 929146
ISED CAB Identifier: DE0007; ISED#: 3699A
Responsible for accreditation scope: Dipl.-Ing. Marco Kullik
Report Template Version: 2019-03-11

2.2 PROJECT DATA

Responsible for testing and report: B.Sc. Jens Dörwald
Employees who performed the tests: documented internally at 7Layers
Date of Report: 2022-03-10
Testing Period: 2021-12-02 to 2022-02-22

2.3 APPLICANT DATA

Company Name: Continental Automotive GmbH
Address: Siemensstrasse 12
93055 Regensburg
Germany
Contact Person: Mrs. Alexandra Anisoreac

2.4 MANUFACTURER DATA

Company Name: please see Applicant Data
Address:
Contact Person:

3 TEST OBJECT DATA

3.1 GENERAL EUT DESCRIPTION

Kind of Device product description	UWB (Ultra Wide Band) and BLE (Bluetooth Low Energy) transceiver module for car access and user localization purposes.
Product name	CMBTRX1
Type	-
Declared EUT data by the supplier	
Power Supply Type	DC
Normal Voltage	12 V
Low Voltage	8 V
High Voltage	16 V
Normal Temperature	20.0 °C
Low Temperature	-40.0 °C
High Temperature	+105.0 °C
Antenna type / Gain	Integrated monopole antenna CH5 / CH6 / CH8 / CH9 Ant1: 6.8 / 7.0 / 6.5 / 5.4 dBi Ant2: 3.9 / 3.4 / 5.0 / 4.8 dBi
OP-Modes	OP-Mode 1: FC1T1ND_lin_C0_PC9 (CH5/9) OP-Mode 2: FC1T1ND_min_C1_PC9 (CH5/9) OP-Mode 3: FC1T2_min_C1_PC10 (CH5/9) OP-Mode 4: ECO_FC1T1ND_min_C1_PC25 (CH5/6/8/9) CHxy_ANT1: fixed on Antenna 1 on the selected channel CHxy_ANT2: fixed on Antenna 2 on the selected channel CHxy_ANT1_ANT2: toggles between Antenna 1 and Antenna 2 on the selected channel
Occupied bandwidth	500 MHz
Highest internal frequency	7987.2 MHz
Ports	Enclosure
Special software used for testing	test software

The main components of the EUT are listed and described in chapter 3.2 EUT Main components.

3.2 EUT MAIN COMPONENTS

Sample Name	Sample Code	Description
EUT A	DE1439005ad01	radiated UWB sample
Sample Parameter	Value	
HW Version	C1	
SW Version	06FF	
Serial No.	20212861002	
Comment		

NOTE: The short description is used to simplify the identification of the EUT in this test report.

3.3 ANCILLARY EQUIPMENT

For the purposes of this test report, ancillary equipment is defined as equipment which is used in conjunction with the EUT to provide operational and control features to the EUT. It is necessary to configure the system in a typical fashion, as a customer would normally use it. But nevertheless Ancillary Equipment can influence the test results.

Device	Details (Manufacturer, Type Model, OUT Code)	Description
-	-	-

3.4 AUXILIARY EQUIPMENT

For the purposes of this test report, auxiliary equipment is defined as equipment which is used temporarily to enable operational and control features especially used for the tests of the EUT which is not used during normal operation or equipment that is used during the tests in combination with the EUT but is not subject of this test report. It is necessary to configure the system in a typical fashion, as a customer would normally use it. But nevertheless Auxiliary Equipment can influence the test results.

Device	Details (Manufacturer, HW, SW, S/N)	Description
-	-	-

3.5 EUT SETUPS

This chapter describes the combination of EUTs and equipment used for testing. The rationale for selecting the EUTs, ancillary and auxiliary equipment and interconnecting cables, is to test a representative configuration meeting the requirements of the referenced standards.

Setup	Combination of EUTs	Description and Rationale
S01_AD01	EUT A	radiated setup

3.6 OPERATING MODES

This chapter describes the operating modes of the EUTs used for testing.

Series like UWB telegrams with dummy data (e.g. 0xCAFECAFECAFECAFE & postamble) with appr. 1.52 ms repetition rate

3.6.1 TEST CHANNELS

Operating frequencies	Centre frequency
	CH5 6489.6 MHz
	CH6 6988.8 MHz
	CH8 7488.0 MHz
	CH9 7987.2 MHz

3.7 PRODUCT LABELLING

3.7.1 FCC ID LABEL

Please refer to the documentation of the applicant.

3.7.2 LOCATION OF THE LABEL ON THE EUT

Please refer to the documentation of the applicant.

4 TEST RESULTS

4.1 -10 dB BANDWIDTH – 15.503(d)

Standard **FCC Part 15 Subpart F**

The test was performed according to:
ANSI C63.10, chapter 10.1

Definition:

The Equipment Under Test (EUT) was set up to perform the occupied bandwidth measurements.

The reference level is the level of the highest amplitude signal observed from the transmitter at either the fundamental frequency or first-order modulation products in all typical modes of operation, including the unmodulated carrier, even if atypical.

The results recorded were measured with the modulation which produce the worst-case (biggest) emission bandwidth.

Test Procedure:

The Equipment Under Test (EUT) was set up on a non-conductive support (tilt device) at 1.5 m height in the fully-anechoic chamber.

The measurement was performed with one height (1.5 m) of the receiving antenna.

The measurement distance was 3m.

A search for the direction of maximum output power level is not performed because this is a relative measurement.

The test procedure for "Evaluation of -10 dB bandwidth" of the ANSI C63.10, Chapter 10.1 was used with the following Spectrum Analyzer settings:

- Resolution Bandwidth (RBW): 1 MHz
- Video Bandwidth (VBW): 3 MHz
- Center Frequency: Nominal channel center frequency
- Span: 1 GHz
- Sweptime: 1s
- Sweep points: 1001
- Sweeps: until trace stabilizes
- Trace: Maxhold
- Detector: Peak

The Test was performed radiated in a Fully Anechoic Chamber in the following setup:

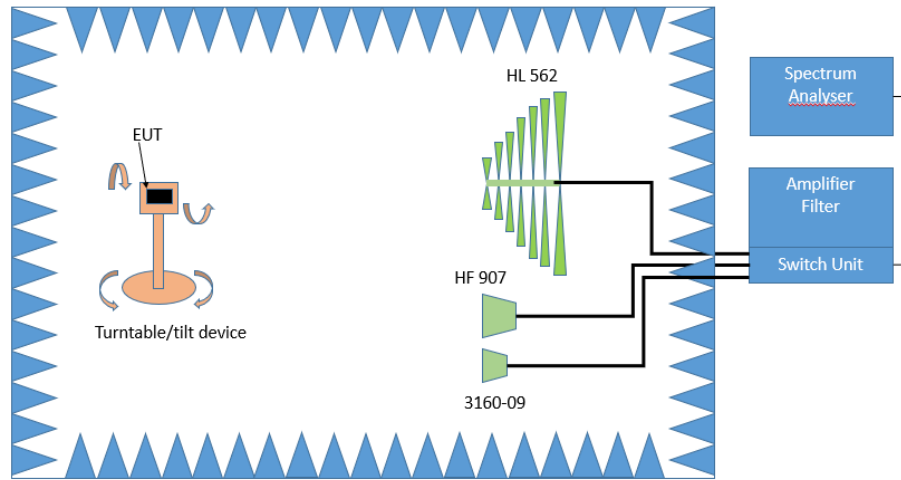

Test Setup; Spurious Emission Radiated (FAC), 30 MHz -26.5 GHz

4.1.1 TEST REQUIREMENTS / LIMITS

FCC Part 15, Subpart F, §15.503 (d)

Ultra-wideband (UWB) transmitter. An intentional radiator that, at any point in time, has a fractional bandwidth equal to or greater than 0.20 or has a UWB bandwidth equal to or greater than 500 MHz, regardless of the fractional bandwidth.

RSS-220, 2.

A UWB device is an intentional radiator that has either a -10 dB bandwidth of at least 500 MHz or a -10 dB fractional bandwidth greater than 0.2.

4.1.2 TEST PROTOCOL

Ambient temperature: 24 °C
Air Pressure: 1019 hPa
Humidity: 31 %

Channel	OP-Mode	Lower -10 dBc Frequency fL [MHz]	Upper -10 dBc Frequency fL [MHz]	10 dBc OWB [MHz]	Limit [MHz]	Margin to Limit [MHz]
CH5_ANT1	OP-Mode 1	6225	6785	560	500	60
CH5_ANT2	OP-Mode 1	6278	6784	506	500	6
CH5_ANT1	OP-Mode 2	6225	6784	559	500	59
CH5_ANT2	OP-Mode 2	6278	6783	505	500	5
CH5_ANT1	OP-Mode 3	6224	6772	548	500	48
CH5_ANT2	OP-Mode 3	6283	6783	500	500	0
CH5_ANT1	OP-Mode 4	6224	6785	561	500	61
CH5_ANT2	OP-Mode 4	6275	6797	522	500	22
CH6_ANT1	OP-Mode 1	6696	7277	581	500	81
CH6_ANT2	OP-Mode 1	6697	7265	568	500	68
CH6_ANT1	OP-Mode 4	6689	7284	595	500	95
CH6_ANT2	OP-Mode 4	6673	7267	594	500	94
CH8_ANT1	OP-Mode 1	7168	7784	616	500	116
CH8_ANT2	OP-Mode 1	7210	7781	571	500	71
CH8_ANT1	OP-Mode 4	7161	7805	644	500	144
CH8_ANT2	OP-Mode 4	7210	7782	572	500	72
CH9_ANT1	OP-Mode 1	7691	8272	581	500	81
CH9_ANT2	OP-Mode 1	7695	8262	567	500	67
CH9_ANT1	OP-Mode 2	7692	8266	574	500	74
CH9_ANT2	OP-Mode 2	7700	8256	556	500	56
CH9_ANT1	OP-Mode 3	7705	8259	554	500	54
CH9_ANT2	OP-Mode 3	7708	8257	549	500	49
CH9_ANT1	OP-Mode 4	7671	8276	605	500	105
CH9_ANT2	OP-Mode 4	7694	8265	571	500	71

4.1.3 MEASUREMENT PLOT (SHOWING THE HIGHEST VALUE, "WORST CASE")

Measurement method = radiated, Channel = 5, Antenna 2, OP-mode 3

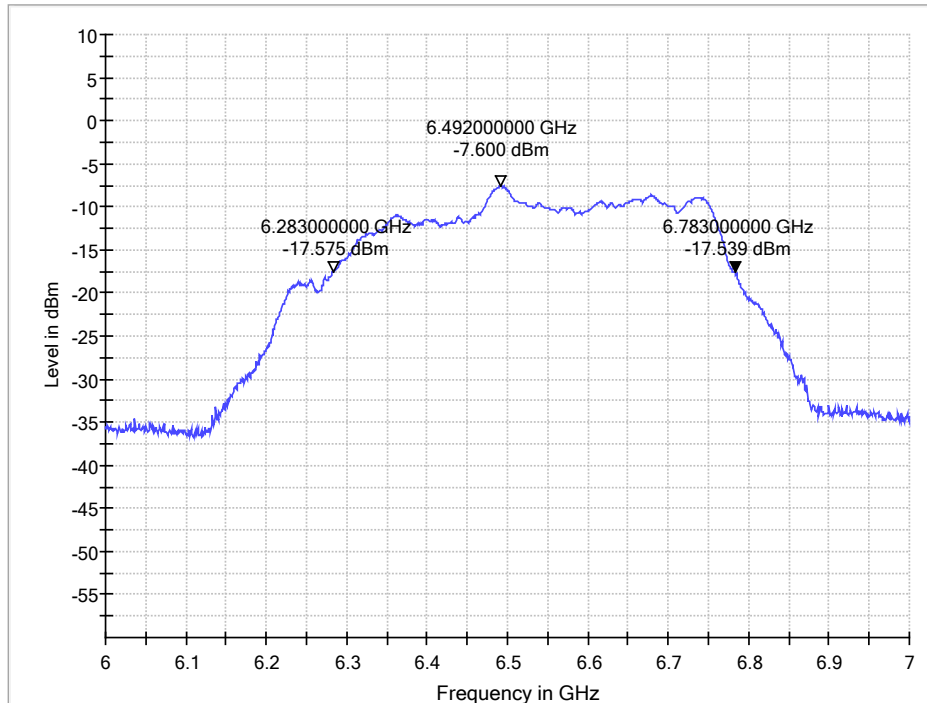

Measurement method = radiated, Channel = 6, Antenna 2, OP-mode 1

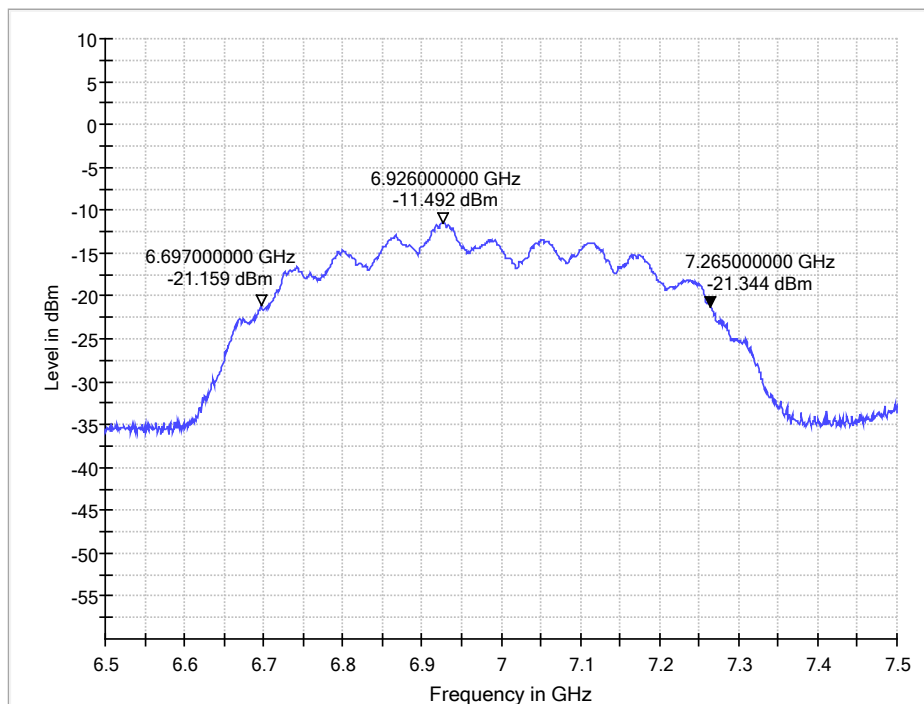

Measurement method = radiated, Channel = 8, Antenna 2, OP-mode 1

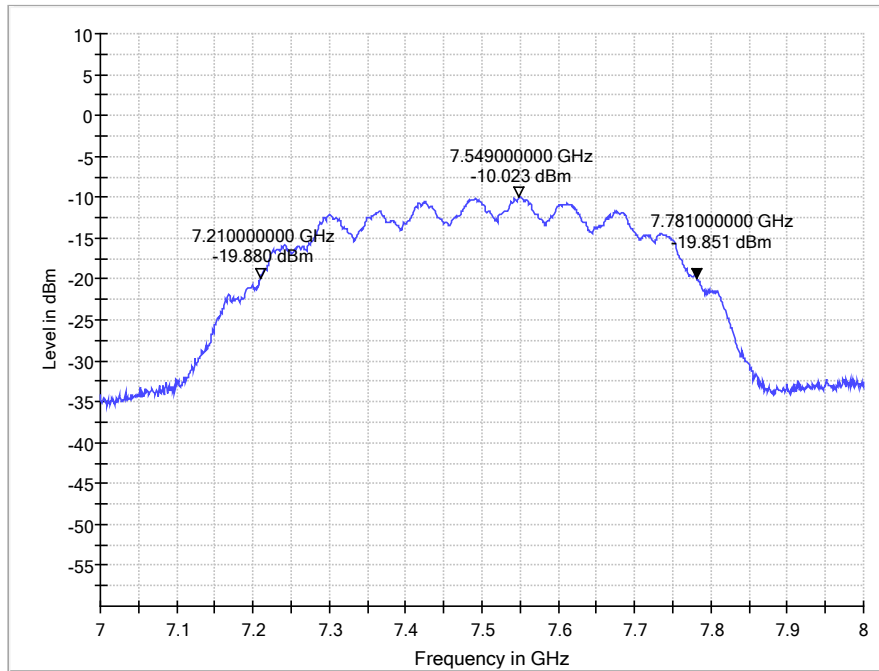

Measurement method = radiated, Channel = 9, Antenna 2, OP-mode 2

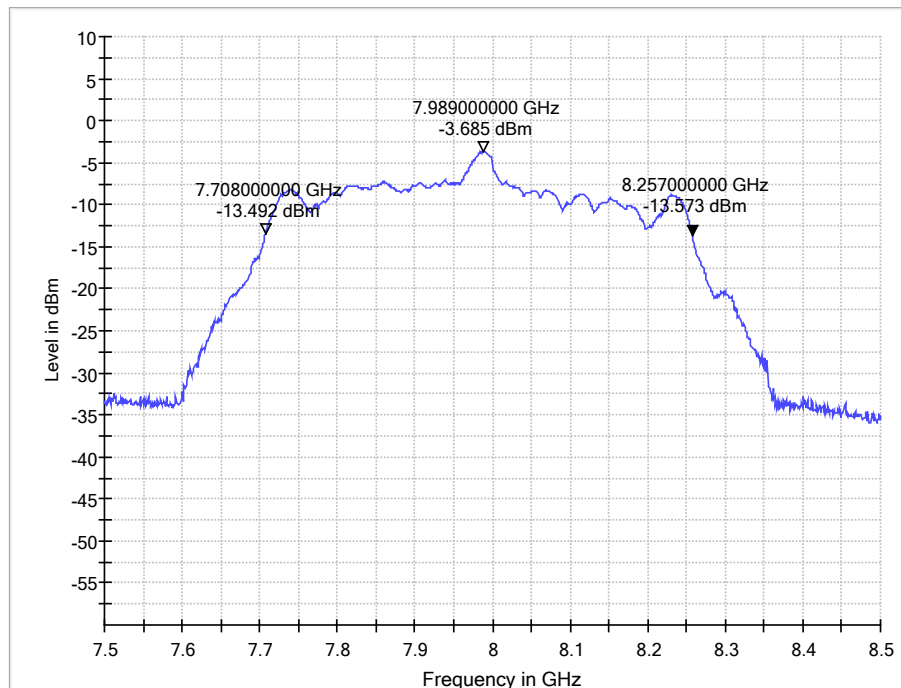

TEST EQUIPMENT USED:

- Radiated Emissions

4.2 PEAK EMISSION – 15.521(e)

Standard **FCC Part 15 Subpart F**

The test was performed according to:

ANSI C63.10, chapter 10.3.5, 10.3.6

Definition:

The maximum peak power specified as e.i.r.p. contained within a 50 MHz bandwidth at the frequency at which the highest mean radiated power occurs, radiated in the direction of the maximum level under the specified conditions of measurement.

Test Procedure:

The Equipment Under Test (EUT) was set up on a non-conductive support (tilt device) at 1.5 m height in the fully-anechoic chamber.

All steps were performed with one height (1.5 m) of the receiving antenna only.

The measurement distance for all steps was 3m.

Step 1: Preliminary scan

This is a preliminary test to identify the direction of maximum output power level of the EUT.

Spectrum analyser settings for step 1:

- Resolution Bandwidth (RBW): 1 MHz
- Video Bandwidth (VBW): 3 MHz
- Detector: RMS
- Center Frequency: Nominal channel center frequency
- Span: 1 GHz
- Sweeptime: 1s
- Sweep points: 1001
- Sweeps: 10
- Trace: Maxhold

Turn table and antenna settings

- Turntable angle range: -180° to 90°
- Turntable step size (azimuth): 45°
- Elevation angle range: 0° - 90°
- Elevation step size: 90°
- Antenna polarisation: Horizontal + Vertical

Step 2: Adjustment measurement

In this step the accuracy of the turntable azimuth and antenna height will be improved. This is necessary to find out the maximum value of every frequency.

For the frequency with the highest power, the turntable azimuth and EUT elevation will be adjusted. The turntable azimuth will slowly vary by $\pm 22.5^{\circ}$. The elevation angle will slowly vary by $\pm 45^{\circ}$. During this action, the value of emission is continuously measured. The turntable azimuth at the highest emission will be recorded and adjusted. In this position, the elevation angle will also slowly vary by $\pm 22.5^{\circ}$ around the elevation angle determined in step one. During this action, the value of emission is also continuously measured. The elevation angle of the highest emission will also be recorded and adjusted.

- Measured frequencies: in step 1 determined frequencies
- Resolution Bandwidth (RBW): 1 MHz
- Video Bandwidth (VBW): 3 MHz
- Detector: RMS
- Sweep time: 100 ms
- Turntable angle range: $\pm 22.5^\circ$ around the determined value of step 1
- EUT elevation angle: $\pm 45^\circ$ around the determined value of step 1
- Antenna Polarisation: max. value determined in step 1

Step 3: Final measurement with the following analyser settings

Analyzer settings:

- Resolution Bandwidth (RBW): 50 MHz
- Video Bandwidth (VBW): 50 MHz
- Center Frequency: Nominal channel center frequency
- Span: 1 GHz
- Sweeptime: 1s
- Sweep points: 1001
- Trace: Maxhold
- Sweeps: until trace stabilizes
- Sweeptime: 1 s
- Detector: Peak

After the measurement, a plot will be generated which contains a diagram with the results of the final measurement. A marker shows the highest emission.

The radiated test was performed with the following setup:

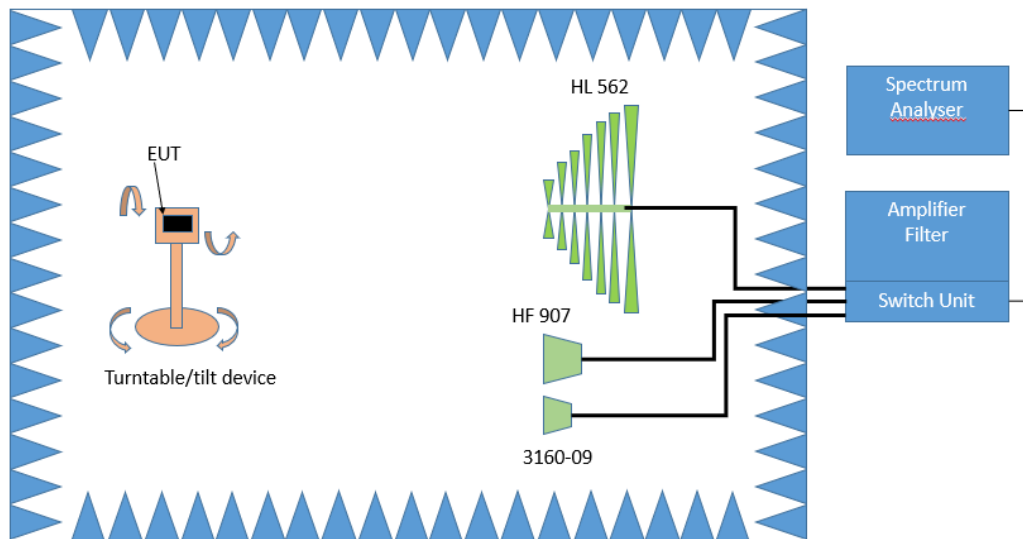

Test Setup; Spurious Emission Radiated (FAC), 30 MHz -26.5 GHz

4.2.1 TEST REQUIREMENTS / LIMITS

FCC Part 15, Subpart F, §15.221 (e)

The frequency at which the highest radiated emission occurs, f_M , must be contained within the UWB bandwidth.

4.2.2 TEST PROTOCOL

Ambient temperature: 24 °C
Air Pressure: 1019 hPa
Humidity: 31 %

Channel	OP-Mode	Highest Peak Emission Power P _{meas} [dBm]	Highest Peak Emission Frequency [MHz]	Limit Maximum Power [dBm]	Margin to Limit [dB]	Lower -10 dB Frequency f _l [MHz]	Upper -10 dB Frequency f _u [MHz]	Highest Peak Emission within UWB Bandwidth
CH5_ANT1	OP-Mode 1	-13.34	6551	0	13.34	6225	6785	yes
CH5_ANT1	OP-Mode 2	-13.44	6545	0	13.44	6225	6784	yes
CH5_ANT1	OP-Mode 3	-5.92	6489	0	5.92	6224	6772	yes
CH5_ANT1	OP-Mode 4	-11.58	6551	0	11.58	6224	6785	yes
CH5_ANT2	OP-Mode 1	-14.06	6678	0	14.06	6278	6784	yes
CH5_ANT2	OP-Mode 2	-14.24	6679	0	14.24	6225	6784	yes
CH5_ANT2	OP-Mode 3	-7.60	6492	0	7.60	6283	6783	yes
CH5_ANT2	OP-Mode 4	-12.59	6678	0	12.59	6275	6797	yes
CH6_ANT1	OP-Mode 1	-12.29	7052	0	12.29	6696	7277	yes
CH6_ANT1	OP-Mode 4	-10.44	7050	0	10.44	6689	7284	yes
CH6_ANT2	OP-Mode 1	-11.49	6926	0	11.49	6697	7265	yes
CH6_ANT2	OP-Mode 4	-8.97	6926	0	8.97	6673	7267	yes
CH8_ANT1	OP-Mode 1	-13.45	7550	0	13.45	7168	7784	yes
CH8_ANT1	OP-Mode 4	-11.46	7551	0	11.46	7161	7805	yes
CH8_ANT2	OP-Mode 1	-10.02	7549	0	10.02	7210	7781	yes
CH8_ANT2	OP-Mode 4	-7.26	7488	0	7.26	7210	7782	yes
CH9_ANT1	OP-Mode 1	-12.36	7933	0	12.36	7691	8272	yes
CH9_ANT1	OP-Mode 2	-12.51	7990	0	12.51	7692	8266	yes
CH9_ANT1	OP-Mode 3	-4.19	7988	0	4.19	7705	8259	yes
CH9_ANT1	OP-Mode 4	-10.61	7987	0	10.61	7671	8276	yes
CH9_ANT2	OP-Mode 1	-12.35	7990	0	12.35	7695	8262	yes
CH9_ANT2	OP-Mode 2	-12.50	7989	0	12.50	7700	8256	yes
CH9_ANT2	OP-Mode 3	-3.69	7989	0	3.69	7708	8257	yes
CH9_ANT2	OP-Mode 4	-10.50	7987	0	10.50	7694	8265	yes

4.2.3 MEASUREMENT PLOT (SHOWING THE HIGHEST VALUE, "WORST CASE")

Measurement method = radiated, Channel = 5, Antenna 1, OP-mode 3

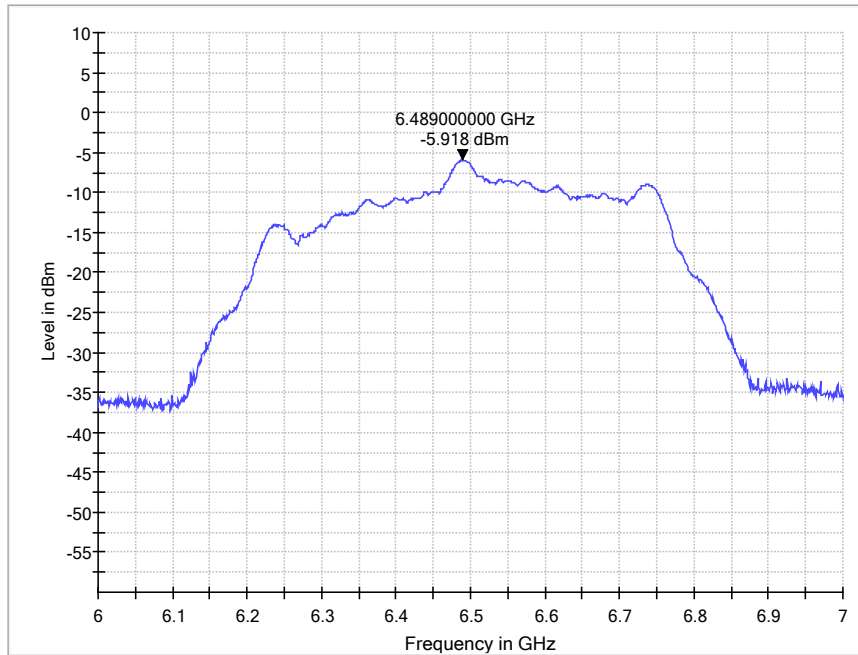

Measurement method = radiated, Channel = 6, Antenna 2, OP-mode 4

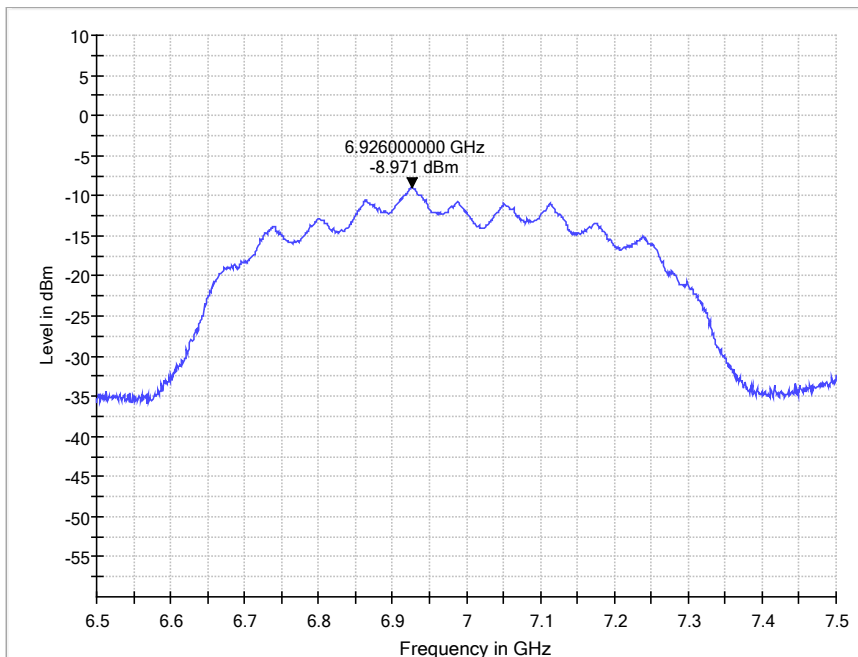

Measurement method = radiated, Channel = 8, Antenna 2, OP-mode 4

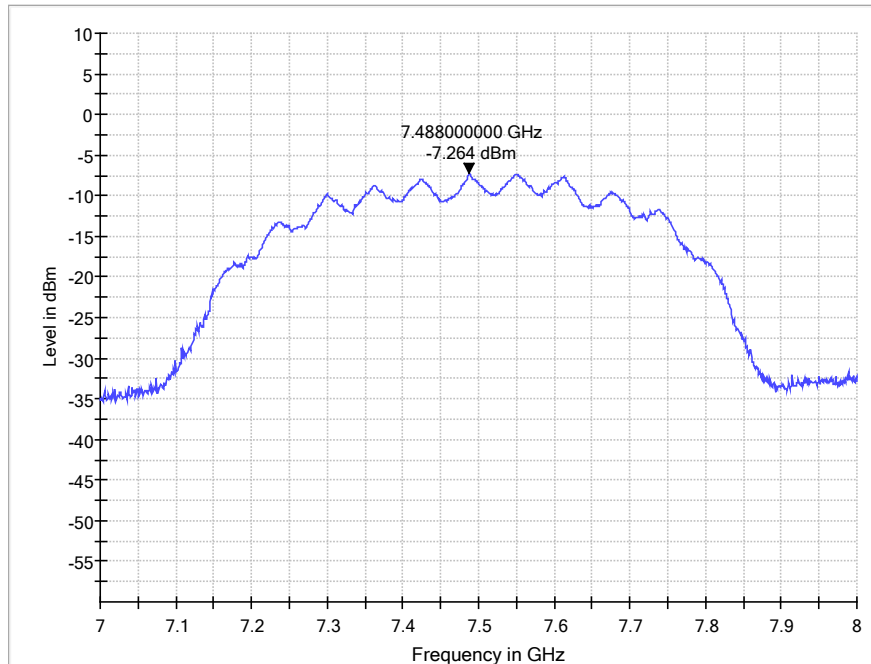

Measurement method = radiated, Channel = 9, Antenna 2, OP-mode 3

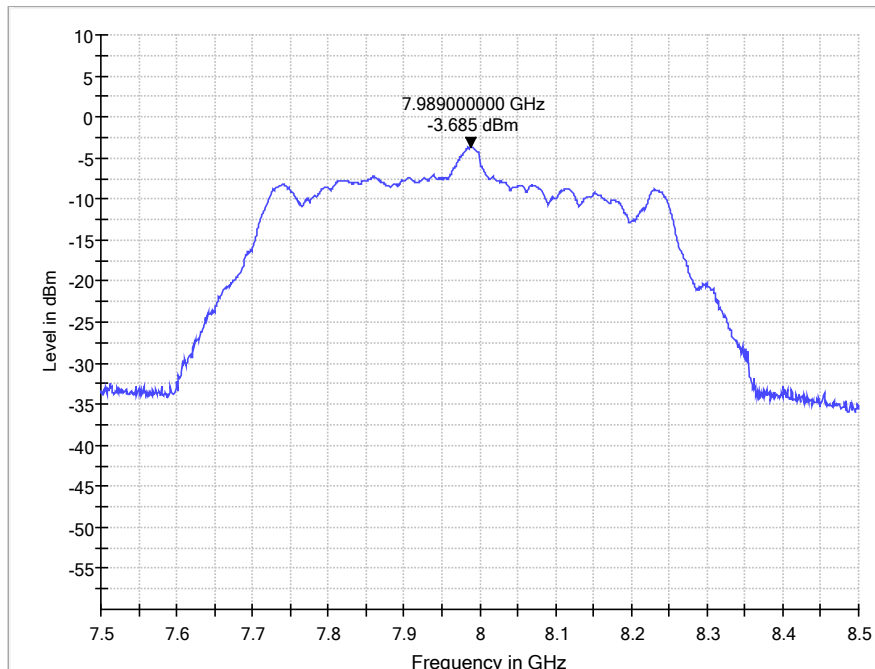

TEST EQUIPMENT USED:
- Radiated Emissions

4.3 RADIATED EMISSIONS

Standard **FCC Part 15 Subpart F**
FCC Part 15 Subpart C

The test was performed according to:
ANSI C63.10, chapter 10.2, 10.3

4.3.1 TEST DESCRIPTION

The test set-up was made in accordance to the general provisions of ANSI C63.10 in a typical installation configuration. The Equipment Under Test (EUT) was set up on a non-conductive table 1.0 x 2.0 m² in the semi-anechoic chamber. The influence of the EUT support table that is used between 30–1000 MHz was evaluated.

The measurement procedure is implemented into the EMI test software EMC32 from R&S. Exploratory tests are performed at 3 orthogonal axes to determine the worst-case orientation of a body-worn or handheld EUT. The final test on all kind of EUTs is also performed at 3 axes. A pre-check is performed while the EUT is powered from a DC power source.

1. Measurement up to 30 MHz

The Loop antenna HFH2-Z2 is used.

Step 1: pre measurement

Settings for step 1:

- Anechoic chamber
- Antenna distance: 3 m
- Antenna height: 1 m
- Detector: Peak-Maxhold
- Frequency range: 0.009 - 0.15 MHz and 0.15 - 30 MHz
- Frequency steps: 0.05 kHz and 2.25 kHz
- IF-Bandwidth: 0.2 kHz and 9 kHz
- Measuring time / Frequency step: 100 ms (FFT-based)

Intention of this step is, to determine the radiated EMI-profile of the EUT. Afterwards the relevant emissions for the final measurement are identified.

Step 2: final measurement

For the relevant emissions determined in step 1, an additional measurement with the following settings will be performed. Intention of this step is to find the maximum emission level.

- Detector: Quasi-Peak (9 kHz - 150 kHz, Peak / Average 150 kHz- 30 MHz)
- Frequency range: 0.009 - 30 MHz
- Frequency steps: measurement at frequencies detected in step 1
- IF-Bandwidth: 0.2 - 10 kHz
- Measuring time / Frequency step: 1 s

2. Measurement above 30 MHz and up to 960 MHz

Step 1: Preliminary scan

This is a preliminary test to identify the highest amplitudes relative to the limit.

Settings for step 1:

- Measurement distance: 3 m
- Detector: Peak-Maxhold / Quasipeak (FFT-based)
- Frequency range: 30 - 1000 MHz
- Frequency steps: 30 kHz
- IF-Bandwidth: 120 kHz

- Measuring time / Frequency step: 100 ms
- Turntable angle range: -180° to 90°
- Turntable step size: 90°
- Height variation range: 1 – 3 m
- Height variation step size: 2 m
- Polarisation: Horizontal + Vertical

Intention of this step is, to determine the radiated EMI-profile of the EUT. Afterwards the relevant emissions for the final measurement are identified.

Step 2: Adjustment measurement

In this step the accuracy of the turntable azimuth and antenna height will be improved. This is necessary to find out the maximum value of every frequency.

For each frequency, which was determined the turntable azimuth and antenna height will be adjusted. The turntable azimuth will slowly vary by $\pm 45^{\circ}$ around this value. During this action, the value of emission is continuously measured. The turntable azimuth at the highest emission will be recorded and adjusted. In this position, the antenna height will also slowly vary by ± 100 cm around the antenna height determined. During this action, the value of emission is also continuously measured. The antenna height of the highest emission will also be recorded and adjusted.

- Detector: Peak – Maxhold
- Measured frequencies: in step 1 determined frequencies
- IF – Bandwidth: 120 kHz
- Measuring time: 100 ms
- Turntable angle range: $\pm 45^{\circ}$ around the determined value
- Height variation range: ± 100 cm around the determined value
- Antenna Polarisation: max. value determined in step 1

Step 3: Final measurement with QP detector

With the settings determined in step 2, the final measurement will be performed:

EMI receiver settings for step 3:

- Detector: Quasi-Peak (< 1 GHz)
- Measured frequencies: in step 1 determined frequencies
- IF – Bandwidth: 120 kHz
- Measuring time: 1 s

After the measurement a plot will be generated which contains a diagram with the results of the preliminary scan and a chart with the frequencies and values of the results of the final measurement.

3. Measurement 960 MHz – 18 GHz

The following modifications apply to the measurement procedure for the frequency range 960 MHz – 18 GHz:

The Equipment Under Test (EUT) was set up on a non-conductive support (tilt device) at 1.5 m height in the fully-anechoic chamber.

All steps were performed with one height (1.5 m) of the receiving antenna only.

The following spectrum analyser settings are used for all steps:

- Measurement distance: 1 m
- Detector: RMS
- RBW: 1 MHz
- VBW: 3 MHz
- Measuring time: 1 ms / Sweep point
- Sweep Points: 1 / MHz [Span]

Step 1: Preliminary scan

Settings for step 1:

- Turntable angle range: -180° to 90°
- Turntable step size: 45°
- Elevation step size: 90°
- Polarisation: Horizontal + Vertical

Step 2: Adjustment measurement

In this step the accuracy of the turntable azimuth elevation will be improved. This is necessary to find out the maximum value of every frequency.

For each frequency, which was determined the turntable azimuth and elevation angle will be adjusted. The turntable azimuth will slowly vary by $\pm 22.5^{\circ}$ around this value. During this action, the value of emission is continuously measured. The turntable azimuth at the highest emission will be recorded and adjusted. In this position, the elevation angle will also slowly vary by $\pm 45^{\circ}$. During this action, the value of emission is also continuously measured. The elevation angle of the highest emission will also be recorded and adjusted.

- Turntable angle range: $\pm 22.5^{\circ}$ around the determined value
- Elevation angle range: $\pm 45^{\circ}$ around the determined value
- Antenna Polarisation: max. value determined in step 1

Step 3: Final measurement with RMS detector

With the settings determined in step 2, the final measurement will be performed:

4. Measurement 18 GHz – 26 GHz

The only difference to measurement procedure in the frequency range 960 MHz – 18 GHz, is the reduced measurement distance of 0.5 m. The measurement procedure is identical.

5. Measurement 26 GHz – 40 GHz

The measurement settings and procedure for this frequency range are identical to the frequency range 960 MHz to 18 GHz.

The Test was performed radiated in a Semi and Fully Anechoic Chamber in the following setups:

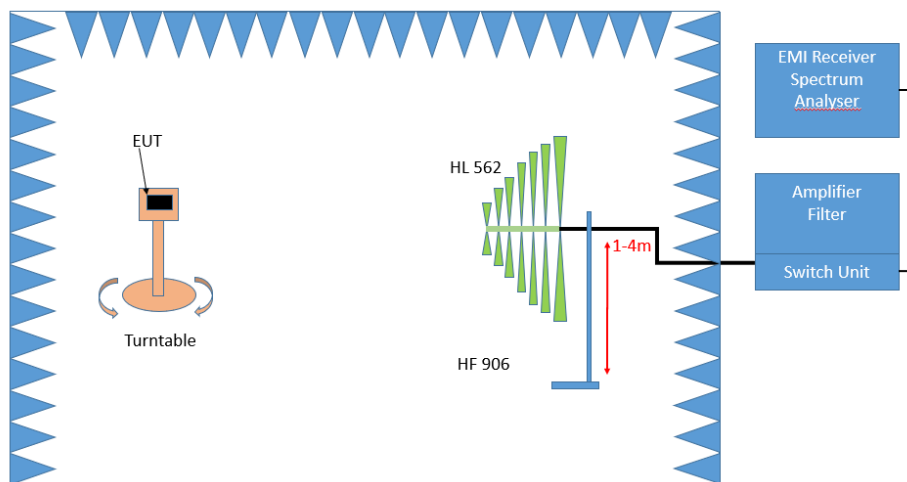

Test Setup; Spurious Emission Radiated (SAC), 30 MHz- 1GHz

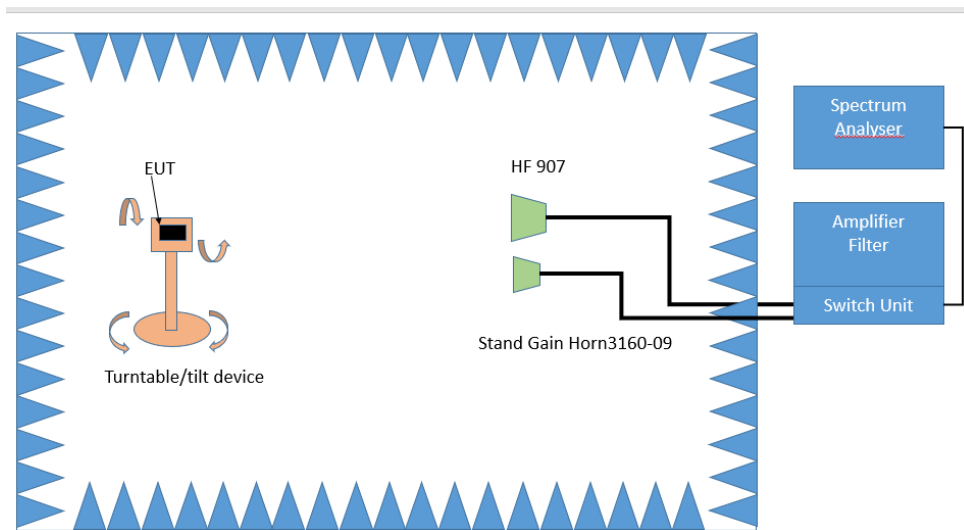

Test Setup; Spurious Emission Radiated (FAC), 1 GHz-26.5 GHz

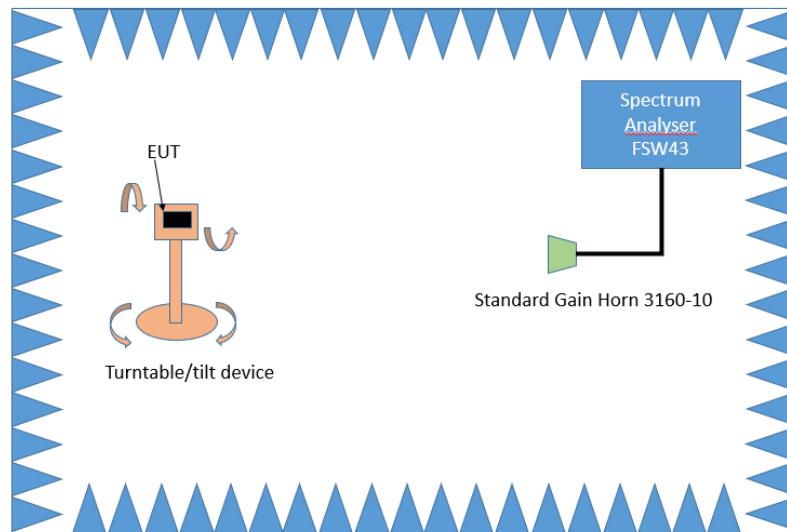

Test Setup; Spurious Emission Radiated (FAC), 26.5 – 40 GHz

4.3.2 TEST REQUIREMENTS / LIMITS

FCC Part 15, Subpart F, §15.519 (c)

The radiated emissions at or below 960 MHz from a device operating under the provisions of this section shall not exceed the emission levels in §15.209. The radiated emissions above 960 MHz from a device operating under the provisions of this section shall not exceed the following average limits when measured using a resolution bandwidth of 1 MHz:

Frequency in MHz	EIRP in dBm
960 – 1610	-75.3
1610 – 1990	-63.3
1990 – 3100	-61.3
3100 – 10600	-41.3
Above 10600	-61.3

FCC Part 15, Subpart C, §15.209, Radiated Emission Limits

Frequency in MHz	Limit ($\mu\text{V}/\text{m}$)	Measurement distance (m)	Limits ($\text{dB}\mu\text{V}/\text{m}$)
0.009 – 0.49	2400/F(kHz)@300m	3	(48.5 – 13.8)@300m
0.49 – 1.705	24000/F(kHz)@30m	3	(33.8 – 23.0)@30m
1.705 – 30	30@30m	3	29.5@30m

The measured values are corrected with an inverse linear distance extrapolation factor (40 dB/decade) according FCC 15.31 (2).

Frequency in MHz	Limit ($\mu\text{V}/\text{m}$)	Measurement distance (m)	Limits ($\text{dB}\mu\text{V}/\text{m}$)
30 – 88	100@3m	3	40.0@3m
88 – 216	150@3m	3	43.5@3m
216 – 960	200@3m	3	46.0@3m

RSS-220, 5.3.1 (c)

Radiated emissions at or below 960 MHz from a device shall not exceed the limits in section 3.4.

RSS-220, 3.4

Radiated emissions at or below 960 MHz for all subclasses of UWB device shall not exceed the following limits. Measurements of radiated emissions at and below 960 MHz are to be made using a CISPR quasi-peak detector. CISPR measurement bandwidth specifications are to be used.

Frequency in MHz	Limit ($\mu\text{V}/\text{m}$)	Measurement distance (m)	Limits ($\text{dB}\mu\text{V}/\text{m}$)
0.009 – 0.49	2400/F(kHz)@300m	3	(48.5 – 13.8)@300m
0.49 – 1.705	24000/F(kHz)@30m	3	(33.8 – 23.0)@30m
1.705 – 30	30@30m	3	29.5@30m

The measured values are corrected with an inverse linear distance extrapolation factor (40 dB/decade) according FCC 15.31 (2).

Frequency in MHz	Limit ($\mu\text{V}/\text{m}$)	Measurement distance (m)	Limits ($\text{dB}\mu\text{V}/\text{m}$)
30 – 88	100@3m	3	40.0@3m
88 – 216	150@3m	3	43.5@3m
216 – 960	200@3m	3	46.0@3m

RSS-220, 5.3.1 (d)

Radiated emissions above 960 MHz from a device shall not exceed the following average limits when measured using a resolution bandwidth of 1 MHz.

Frequency in MHz	EIRP in dBm
960 – 1610	-75.3
1610 – 4.750	-70.0
4750 – 10600	-41.3
Above 10600	-61.3

4.3.3 TEST PROTOCOL

Ambient
 temperature: 23-24 °C
 Air Pressure: 1000–1016 hPa
 Humidity: 38–41 %

Operating Band: 3100 - 10600 MHz [FCC]						
Operating Mode	Spurious Freq. [MHz]	Spurious Level [dBm]	Detector	RBW [kHz]	Limit [dBm]	Margin to Limit [dB]
CH5_ANT1 OP-Mode 3	-	-	-	-	-61.3	-
CH6_ANT2 OP-Mode 4	-	-	-	-	-61.3	-
CH8_ANT2 OP-Mode 4	-	-	-	-	-61.3	-
CH9_ANT2 OP-Mode 3	-	-	-	-	-61.3	-

Operating Band: 3100 - 10600 MHz [ISED RSS-220]						
Operating Frequency	Spurious Freq. [MHz]	Spurious Level [dBm]	Detector	RBW [kHz]	Limit [dBm]	Margin to Limit [dB]
CH5_ANT1 OP-Mode 3	-	-	-	-	-70.0	-
CH6_ANT2 OP-Mode 4	-	-	-	-	-70.0	-
CH8_ANT2 OP-Mode 4	-	-	-	-	-70.0	-
CH9_ANT2 OP-Mode 3	-	-	-	-	-70.0	-

Operating Band: 3100 - 10600 MHz [ISED RSS-Gen]						
Operating Frequency	Spurious Freq. [MHz]	Spurious Level [dBm]	Detector	RBW [kHz]	Limit [dBm]*)	Margin to Limit [dB]
CH5_ANT1 OP-Mode 3	-	-	-	-	-31.7	-
CH6_ANT2 OP-Mode 4	-	-	-	-	-31.7	-
CH8_ANT2 OP-Mode 4	-	-	-	-	-31.7	-
CH9_ANT2 OP-Mode 3	-	-	-	-	-31.7	-

*) Limit calculation RSS-Gen:

- Above 906 MHz → 500 μV/m@3m → 54 dBμV/m@3m
- P(EIRP)[dBm] = E[dBμV/m@3m] - 95.2 → Limit: P(EIRP) = -41.2 dBm
- Correction due to different measurement distance: 3m → 1m: +9.5 dB → Limit: -31.7 dBm

Remark: Please see next sub-clause for the measurement plot.

4.3.4 MEASUREMENT PLOT (SHOWING THE HIGHEST VALUE, "WORST CASE")

Measurement method = radiated, Channel = 5, Antenna 1, OP-mode 3
 Frequency range 9 kHz – 30 MHz

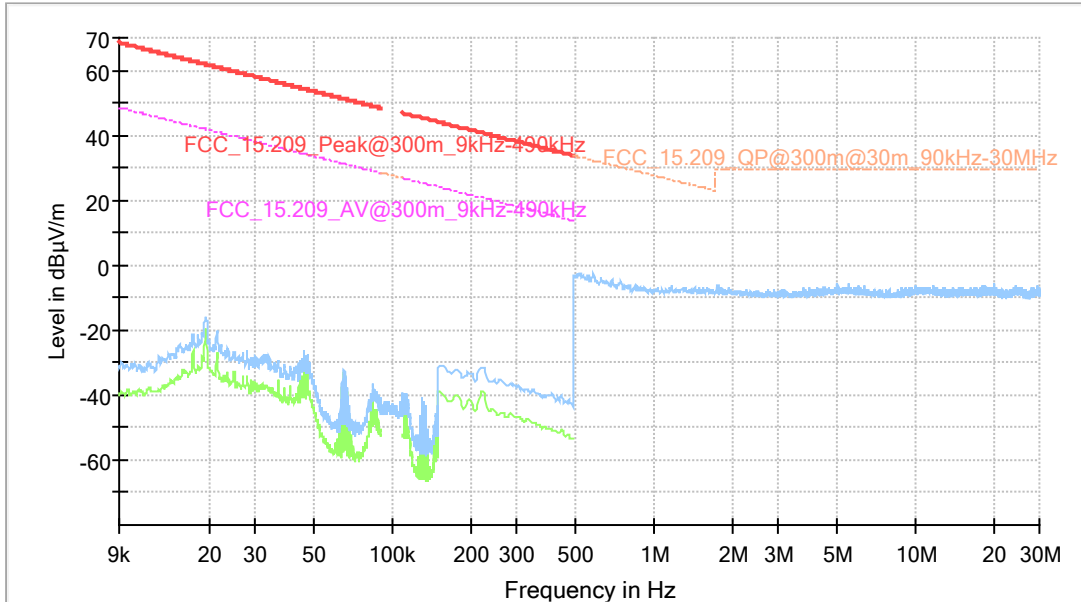

Measurement method = radiated, Channel = 6, Antenna 2, OP-mode 4
 Frequency range 9 kHz – 30 MHz

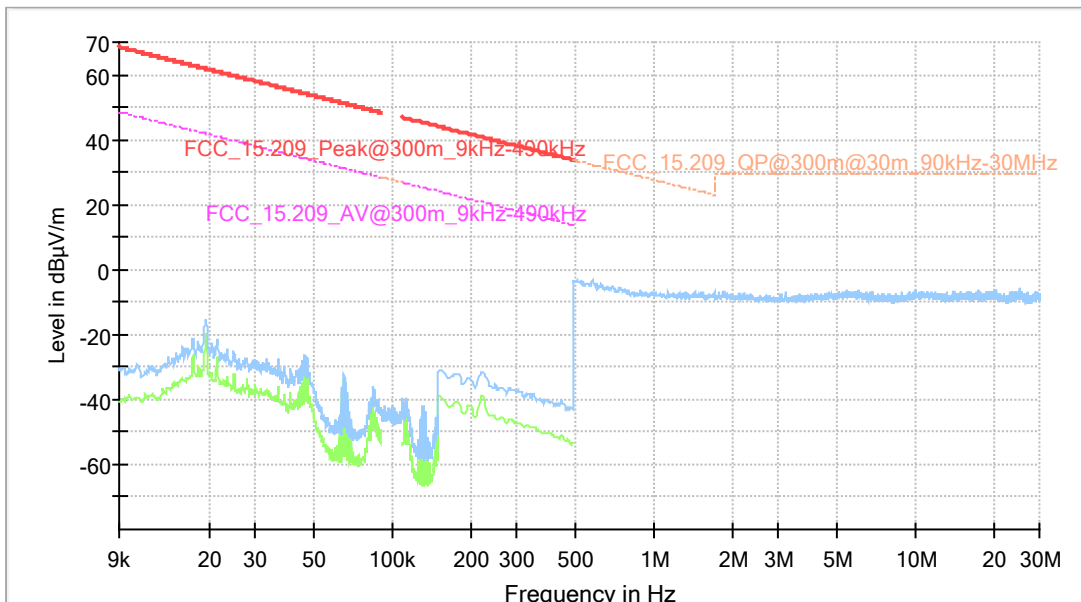

Measurement method = radiated, Channel = 8, Antenna 2, OP-mode 4
Frequency range 9 kHz – 30 MHz

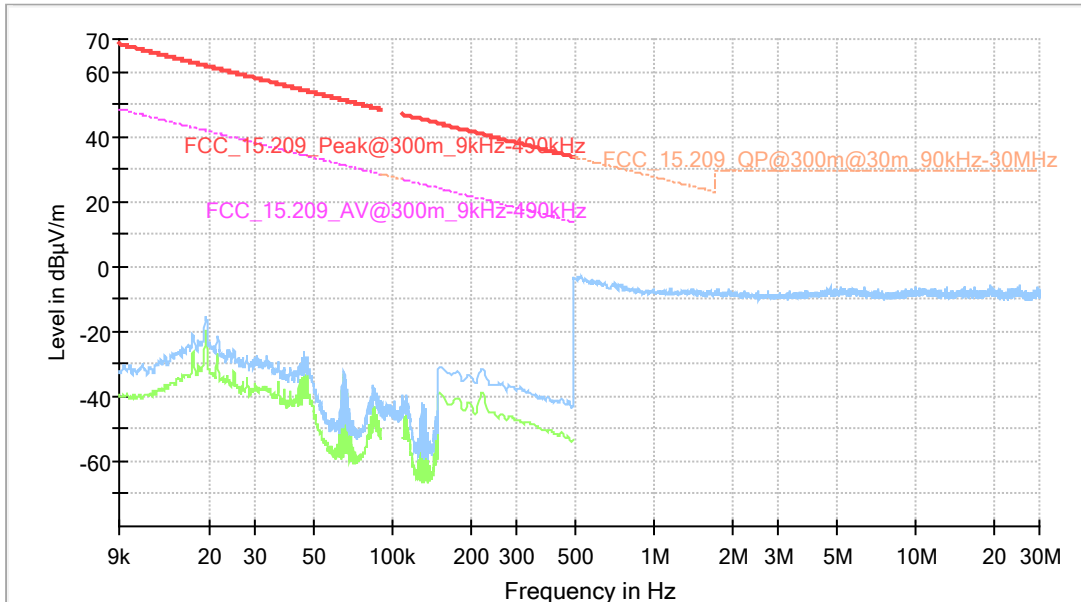

Measurement method = radiated, Channel = 9, Antenna 2, OP-mode 3
Frequency range 9 kHz – 30 MHz

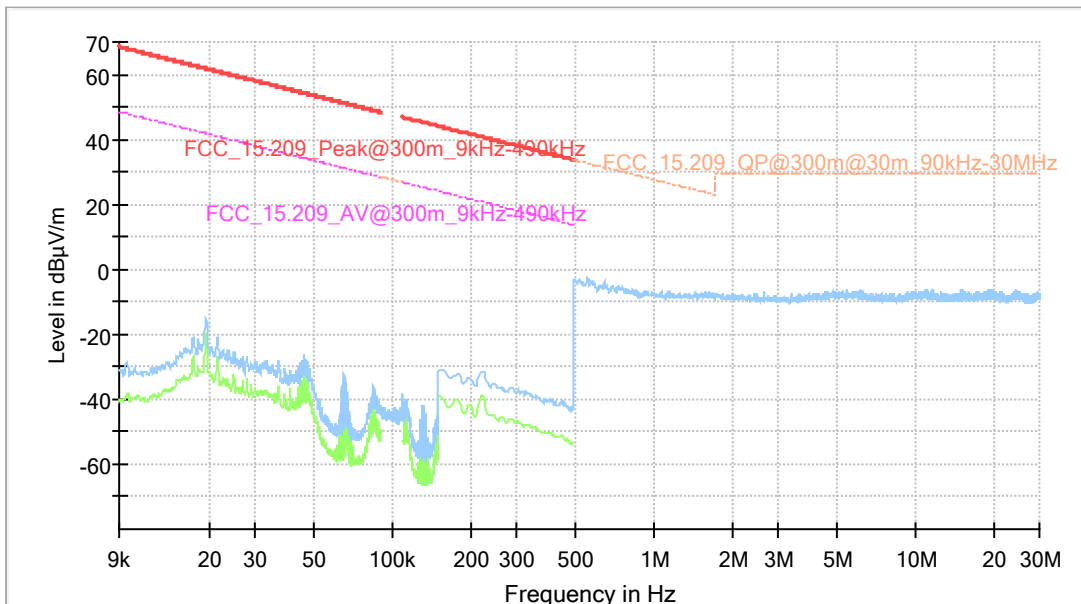

Measurement method = radiated, Channel = 5, Antenna 1, OP-mode 3
Frequency range 30 MHz – 960 MHz

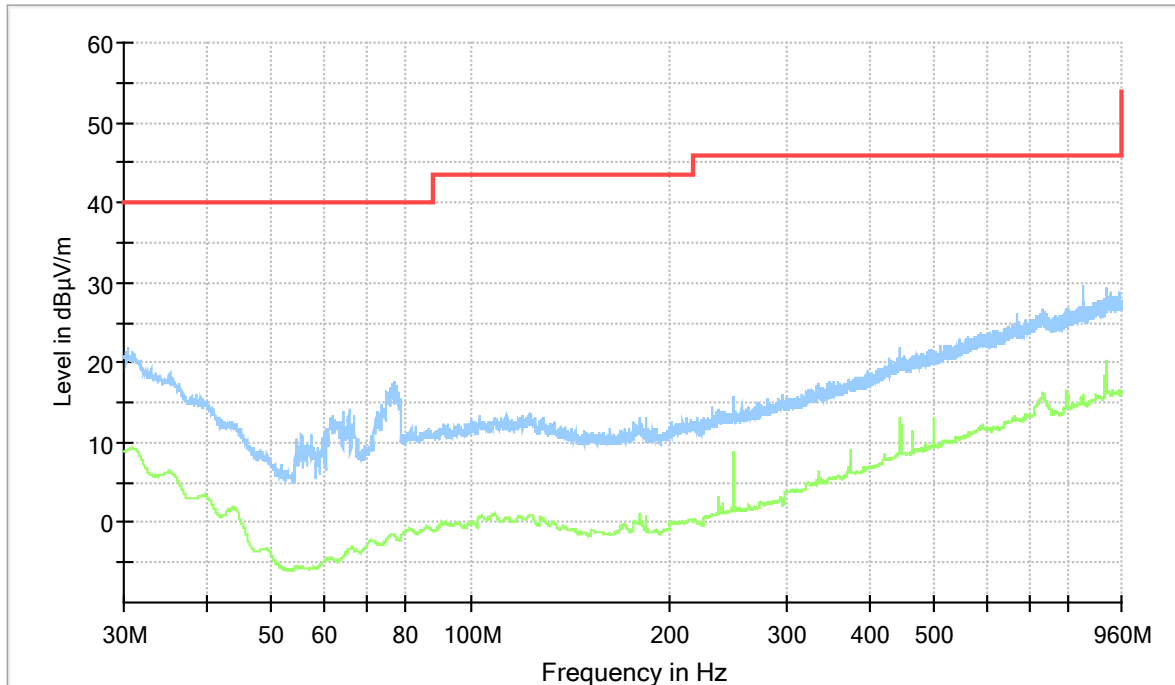

Measurement method = radiated, Channel = 6, Antenna 2, OP-mode 4
Frequency range 30 MHz – 960 MHz

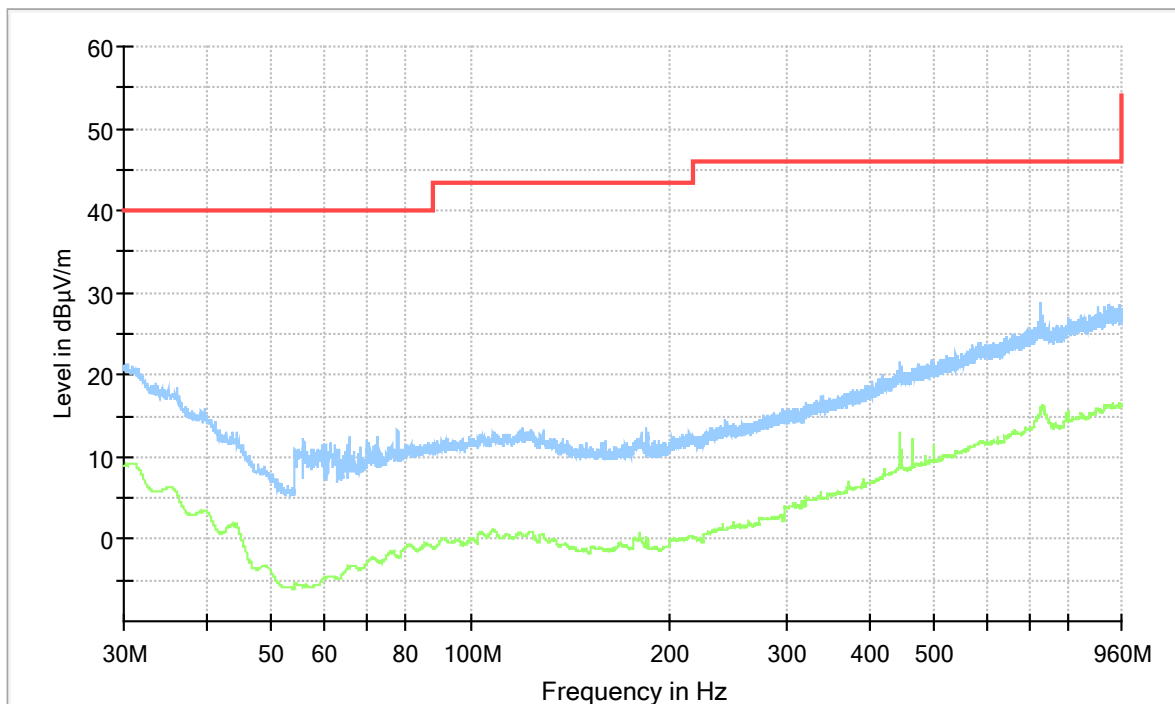

Measurement method = radiated, Channel = 8, Antenna 2, OP-mode 4
Frequency range 30 MHz – 960 MHz

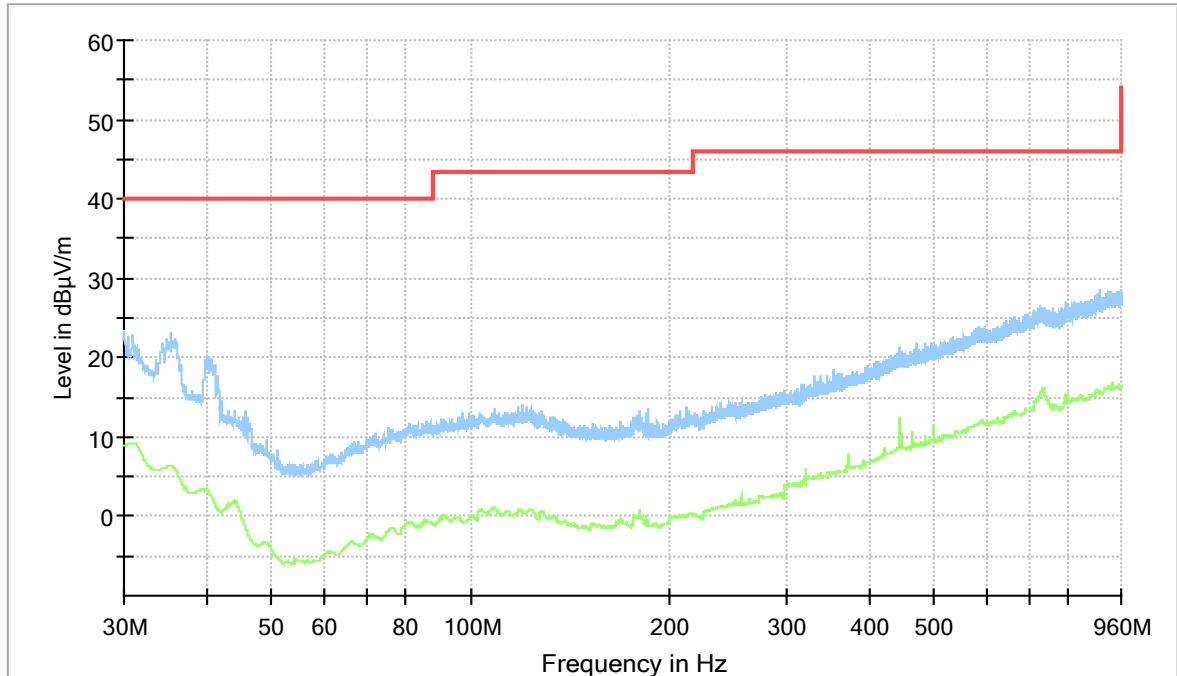

Measurement method = radiated, Channel = 9, Antenna 2, OP-mode 3
Frequency range 30 MHz – 960 MHz

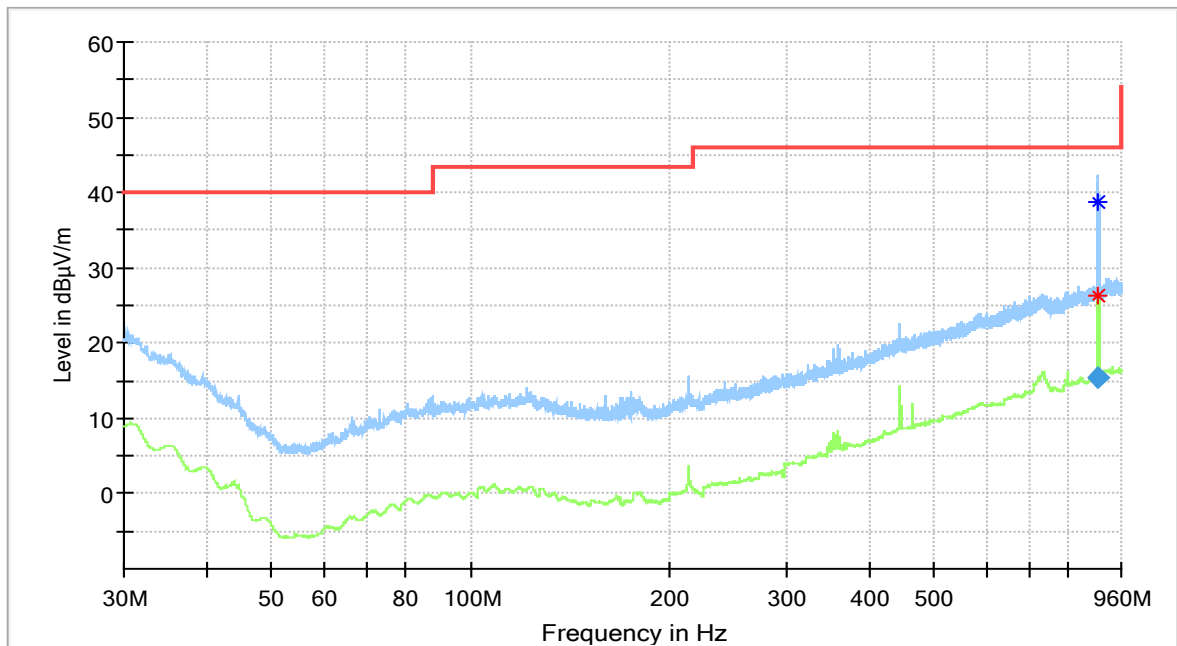

Frequency (MHz)	QuasiPeak (dBµV/m)	Limit (dBµV/m)	Margin (dB)	Meas. Time (ms)	Bandwidth (kHz)	Height (cm)	Pol	Azimuth (deg)	Corr. (dB/m)
882.210000	15.43	46.00	30.57	1000.0	120.000	395.0	V	129.0	24.6

Measurement method = radiated, Channel = 5, Antenna 1, OP-mode 3
Frequency range 960 MHz – 12.4 GHz

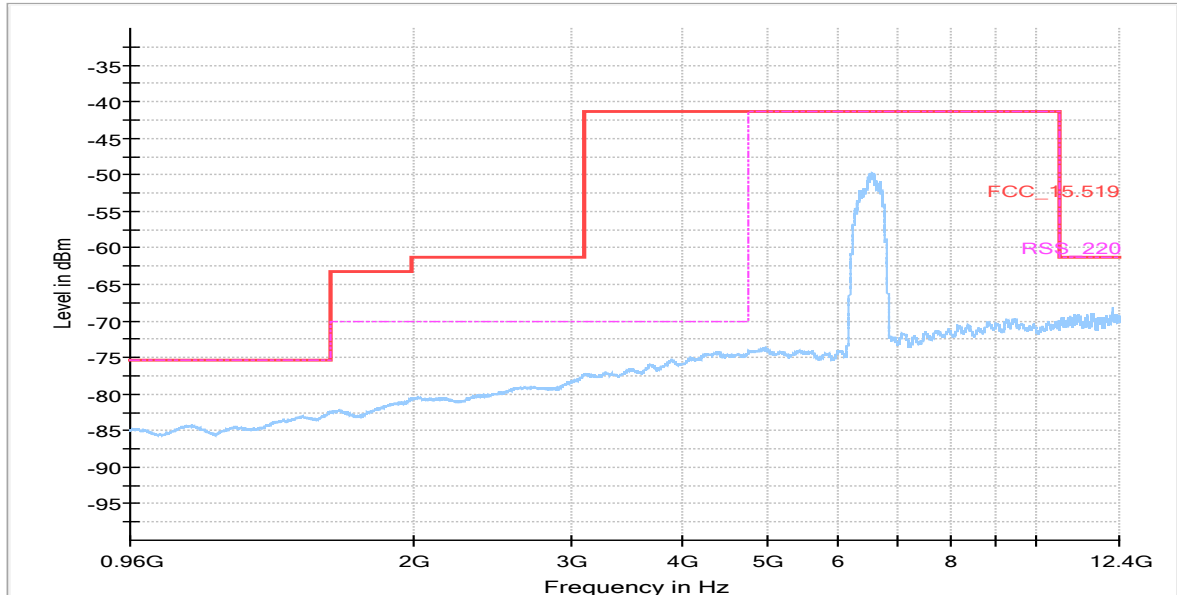

Measurement method = radiated, Channel = 6, Antenna 2, OP-mode 4
Frequency range 960 MHz – 12.4 GHz

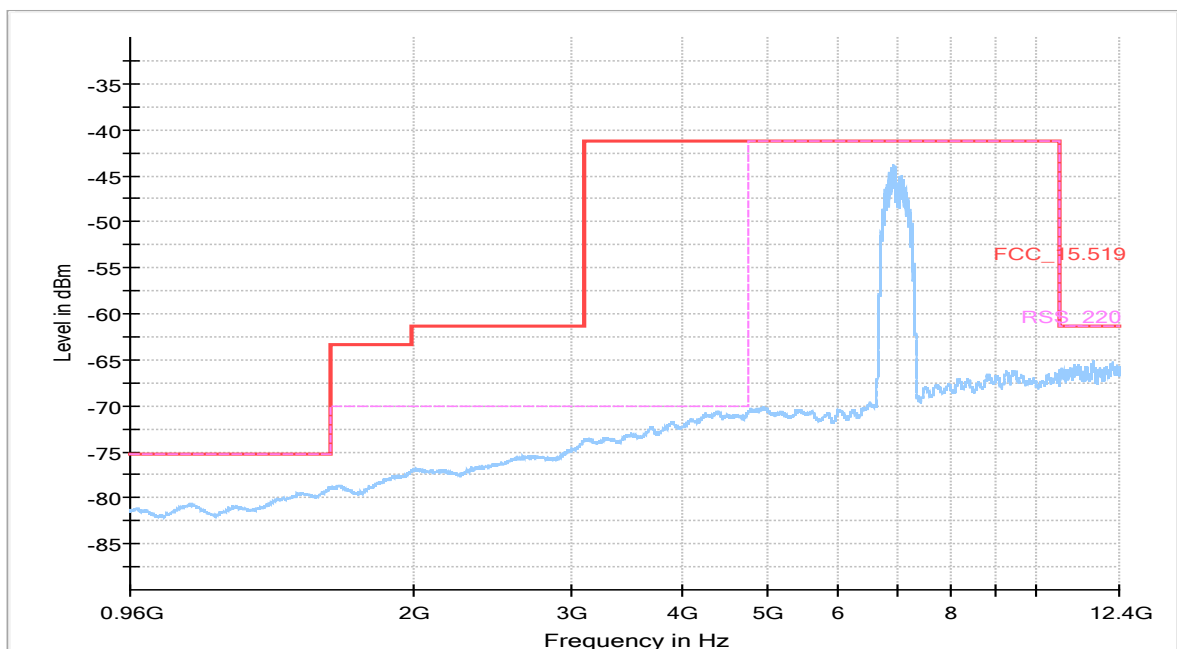

Measurement method = radiated, Channel = 8, Antenna 2, OP-mode 4
 Frequency range 960 MHz – 12.4 GHz

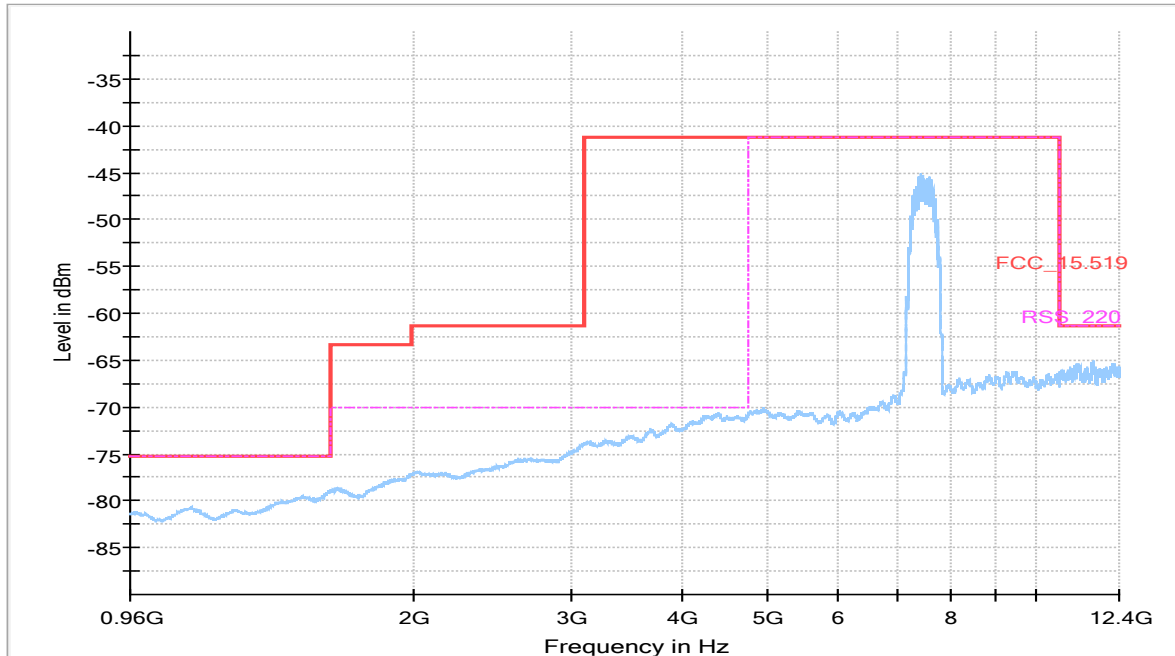

Measurement method = radiated, Channel = 9, Antenna 2, OP-mode 3
 Frequency range 960 MHz – 12.4 GHz

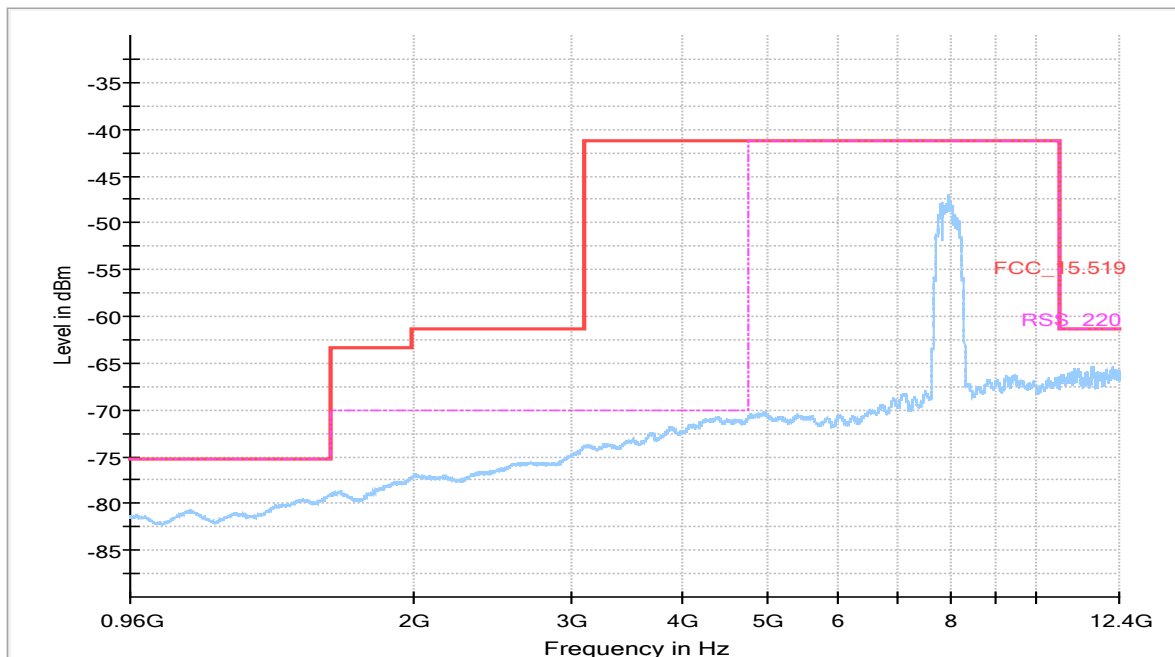

Measurement method = radiated, Channel = 5, Antenna 1, OP-mode 3
Frequency range 12.4 GHz - 18 GHz

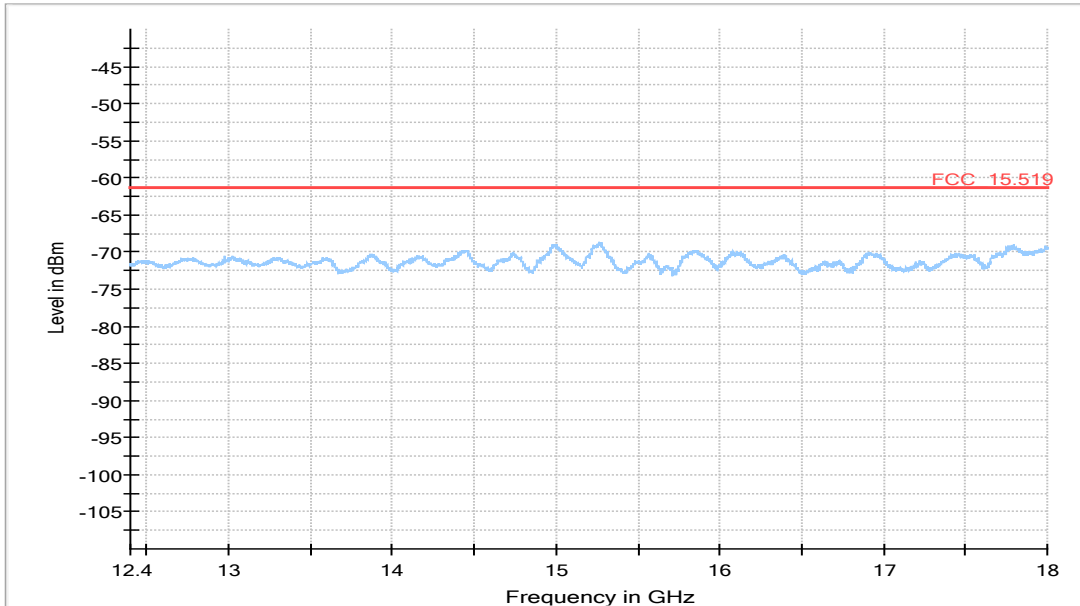

Measurement method = radiated, Channel = 6, Antenna 2, OP-mode 4
Frequency range 12.4 GHz - 18 GHz

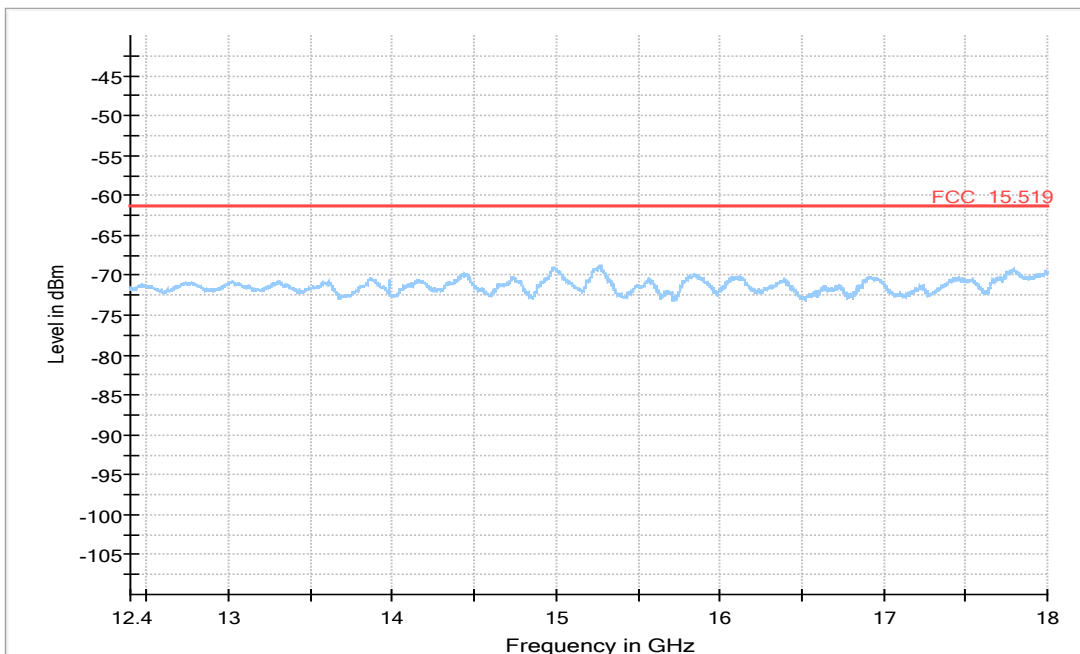

Measurement method = radiated, Channel = 8, Antenna 2, OP-mode 4
Frequency range 12.4 GHz - 18 GHz

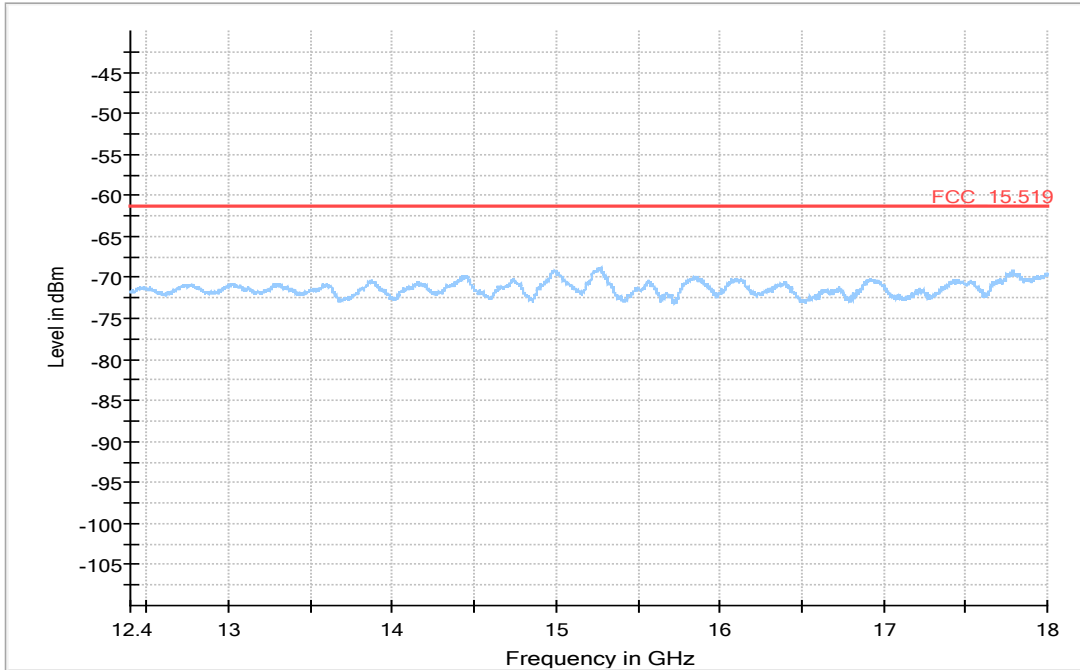

Measurement method = radiated, Channel = 9, Antenna 2, OP-mode 3
Frequency range 12.4 GHz - 18 GHz

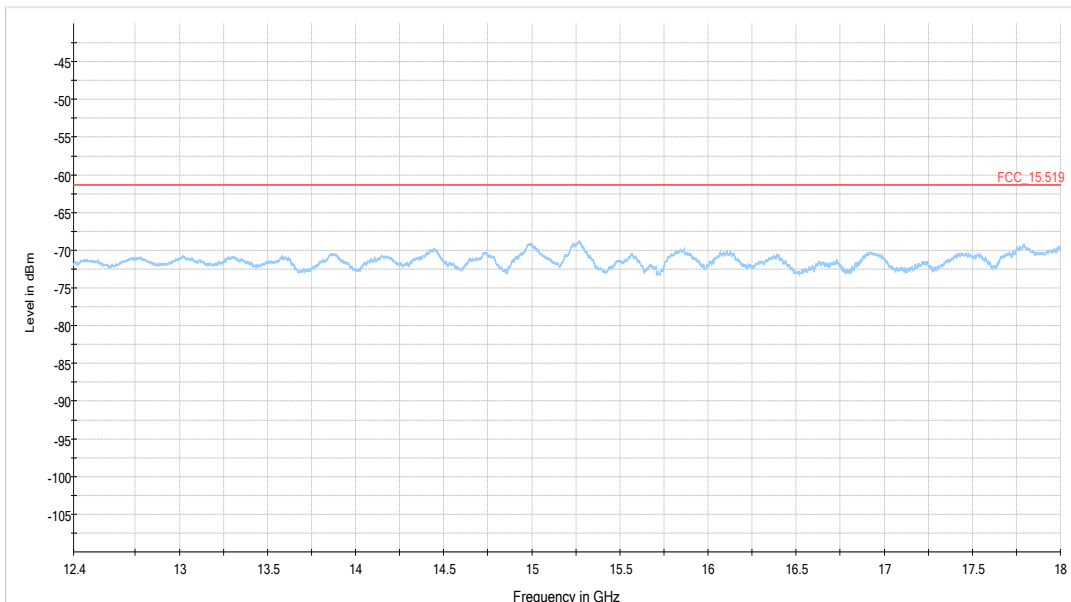

Measurement method = radiated, Channel = 5, Antenna 1, OP-mode 3
Frequency range 18 GHz - 26 GHz

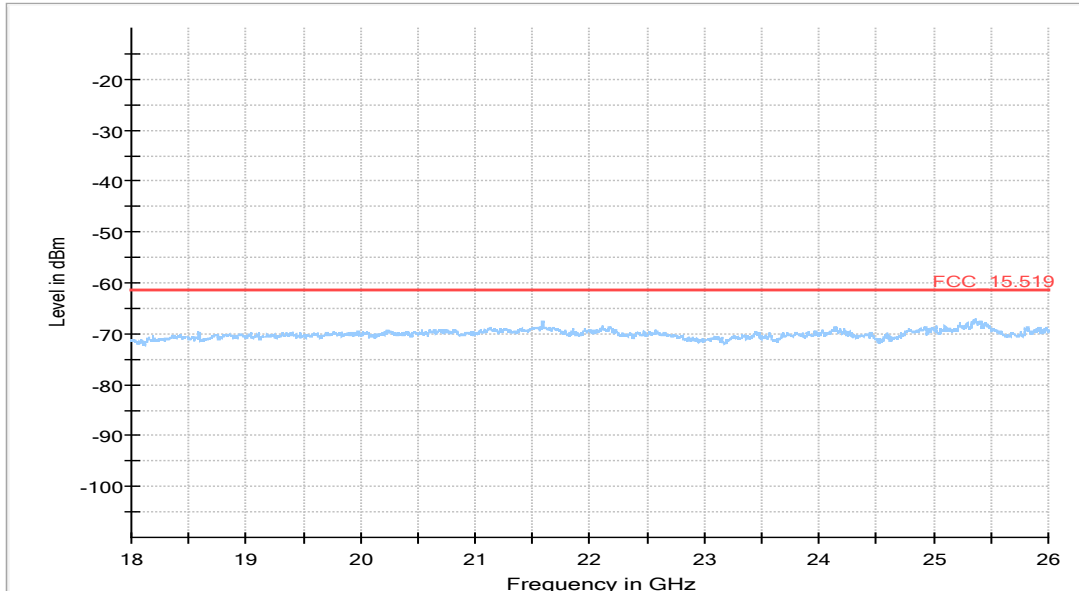

Measurement method = radiated, Channel = 6, Antenna 2, OP-mode 4
Frequency range 18 GHz - 26 GHz

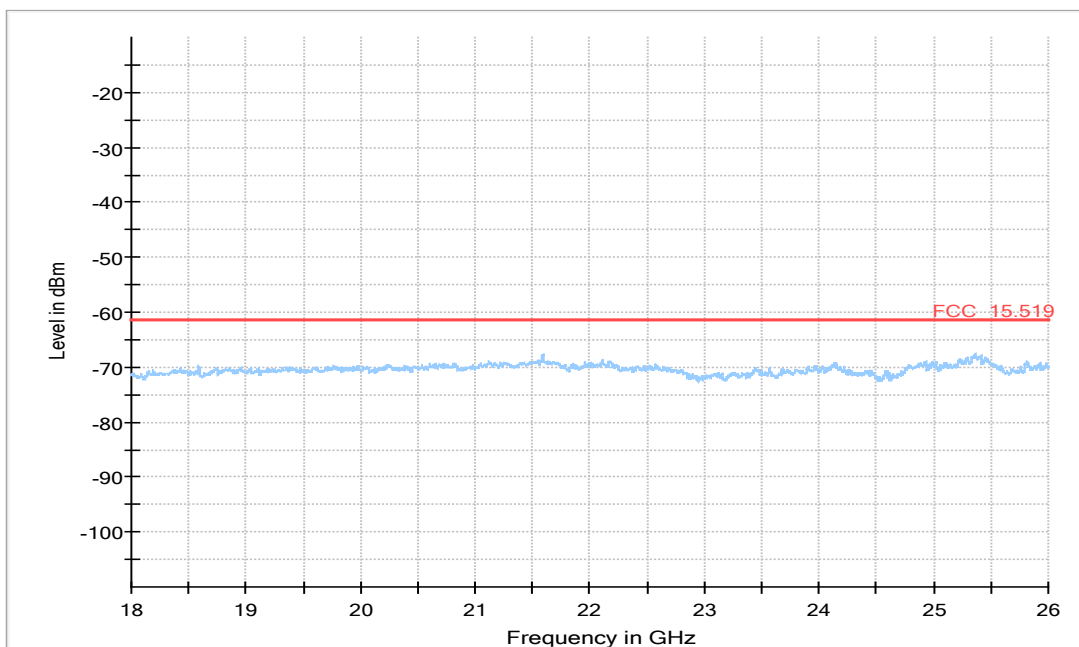

Measurement method = radiated, Channel = 8, Antenna 2, OP-mode 4
Frequency range 18 GHz - 26 GHz

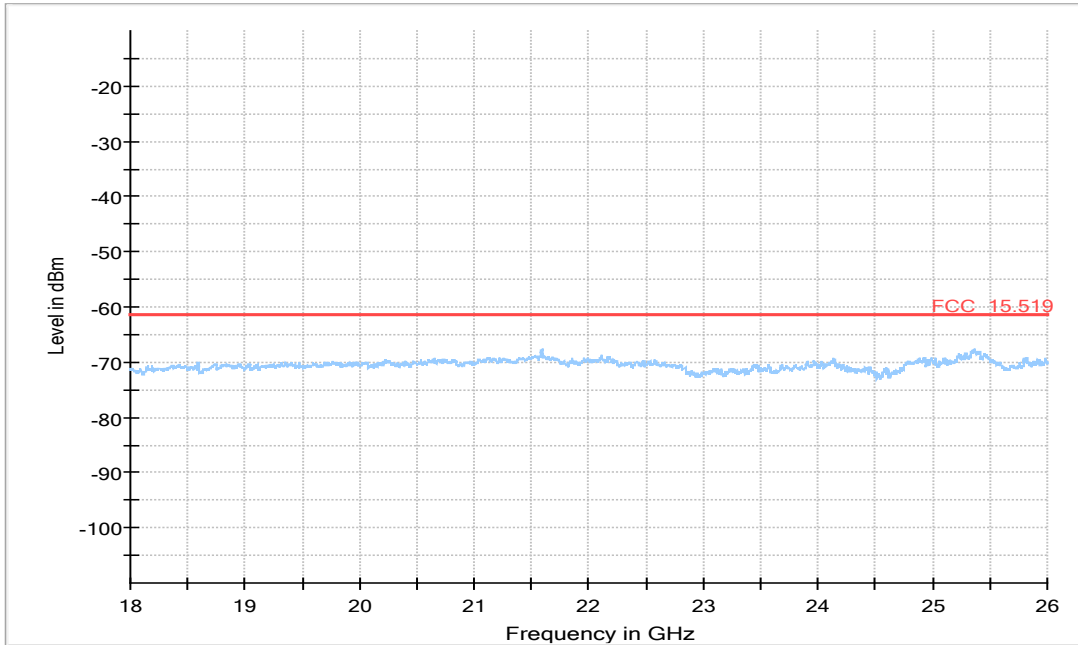

Measurement method = radiated, Channel = 9, Antenna 2, OP-mode 3
Frequency range 18 GHz - 26 GHz

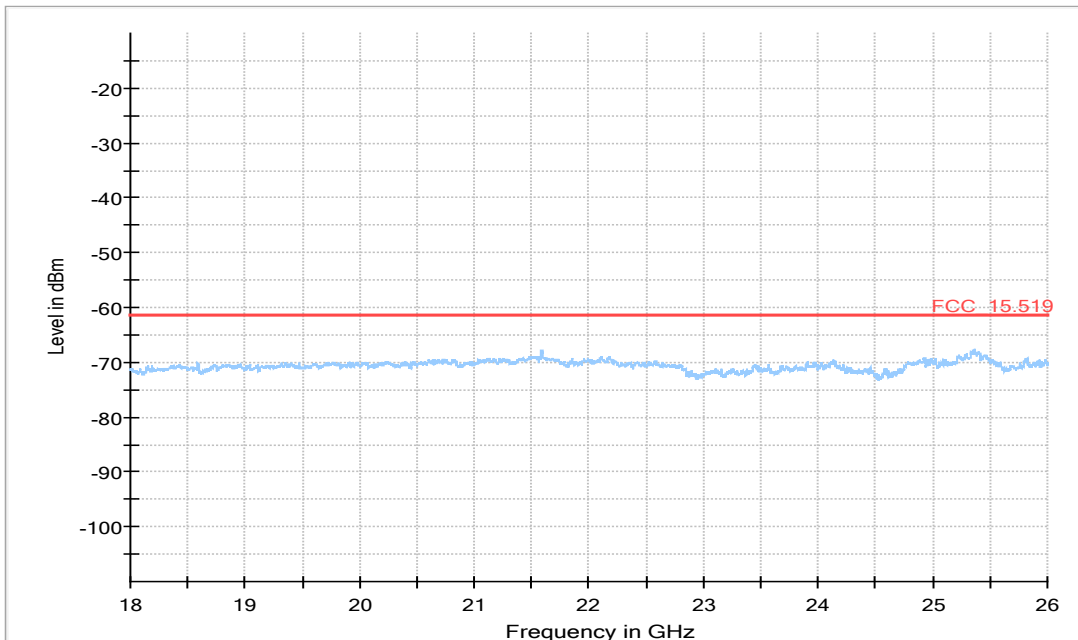

Measurement method = radiated, Channel = 5, Antenna 1, OP-mode 3
26 GHz – 40 GHz

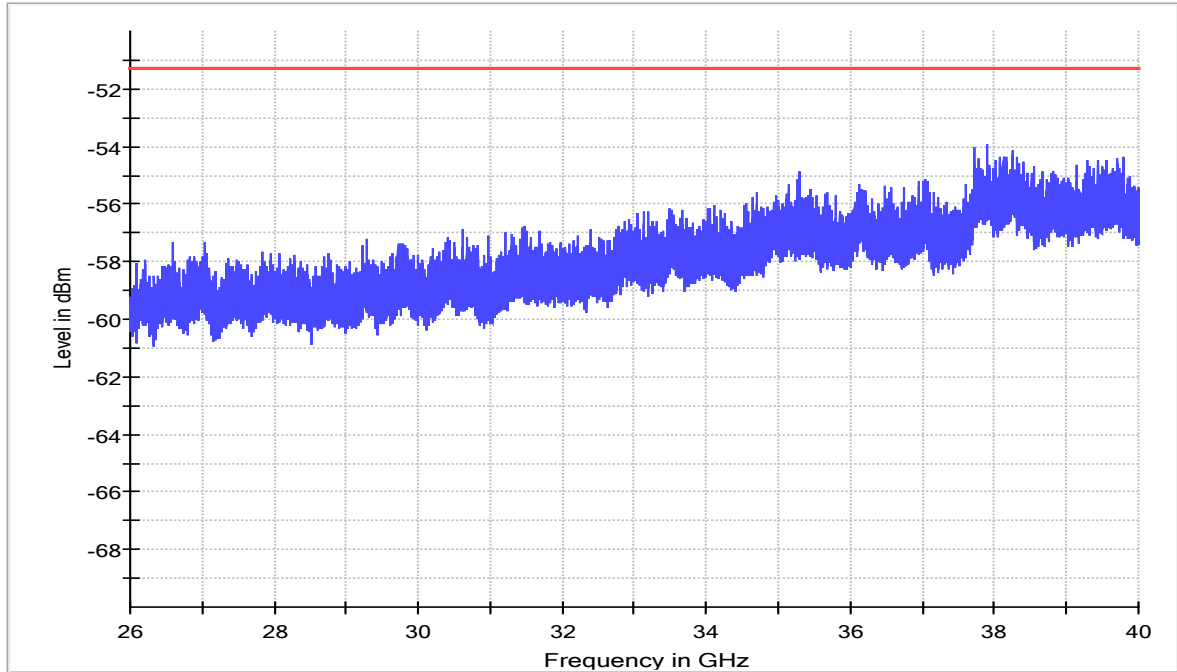

Measurement method = radiated, Channel = 6, Antenna 2, OP-mode 4
26 GHz – 40 GHz

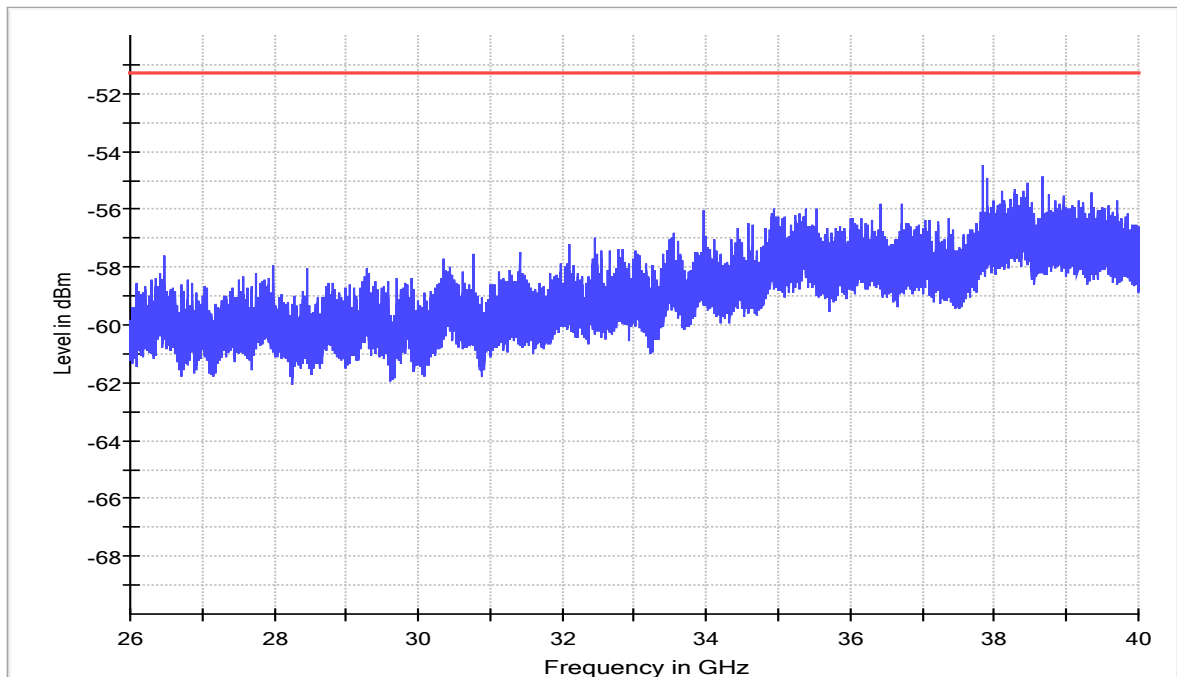

Measurement method = radiated, Channel = 8, Antenna 2, OP-mode 4
26 GHz – 40 GHz

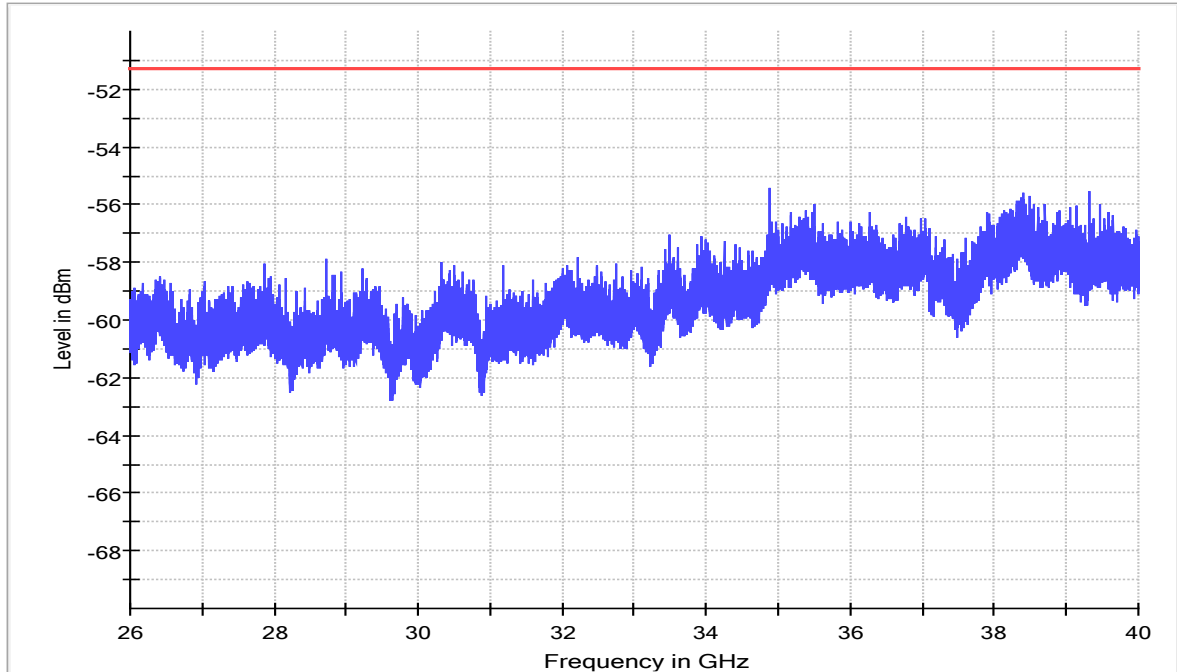

Measurement method = radiated, Channel = 9, Antenna 2, OP-mode 3
26 GHz – 40 GHz

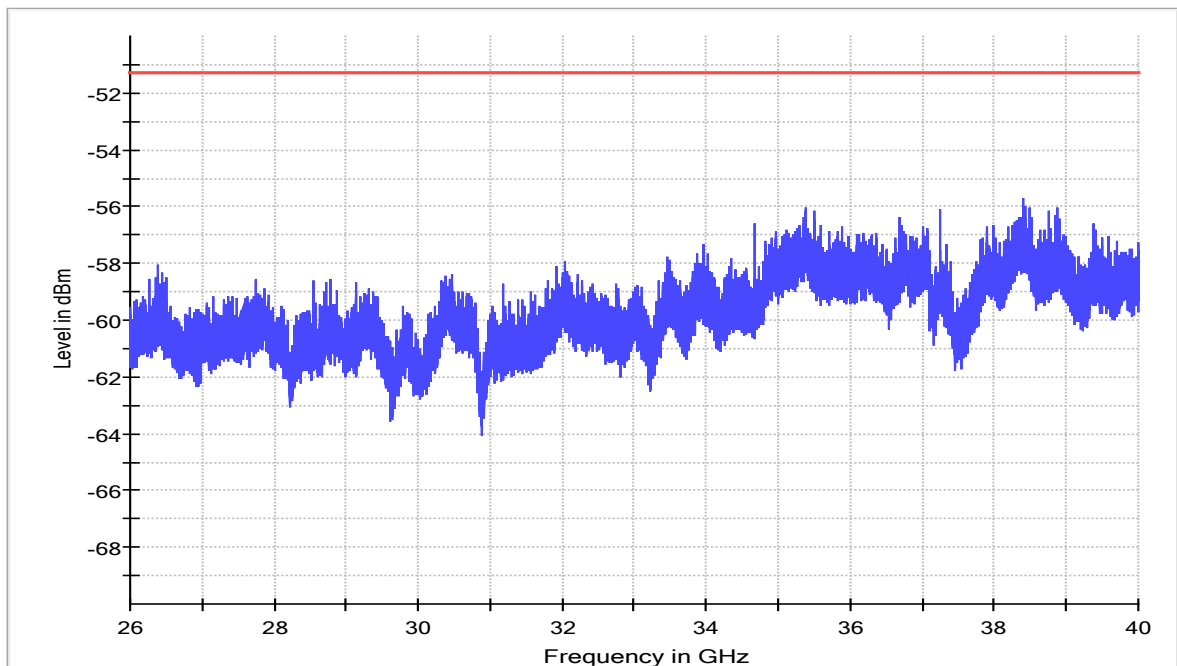

4.3.5 TEST EQUIPMENT USED

- Radiated Emissions

4.4 RADIATED EMISSIONS IN GNSS BANDS

Standard **FCC Part 15 Subpart F**
FCC Part 15 Subpart C

The test was performed according to:
ANSI C63.10, chapter 10.3.10

4.4.1 TEST DESCRIPTION

The test set-up was made in accordance to the general provisions of ANSI C63.10 in a typical installation configuration. The Equipment Under Test (EUT) was set up on a non-conductive support (tilt device) at 1.5 m height in the fully-anechoic chamber.

All steps were performed with one height (1.5 m) of the receiving antenna only.

The measurement procedure is implemented into the EMI test software EMC32 from R&S.

Exploratory tests are performed at 3 orthogonal axes to determine the worst-case orientation of a body-worn or handheld EUT. The final test on all kind of EUTs is also performed at 3 axes. A pre-check is performed while the EUT is powered from a DC power source.

After the measurement a plot will be generated which contains a diagram with the results of the preliminary scan and a chart with the frequencies and values of the results of the final measurement.

1. Measurement 1164 MHz – 1240 MHz, 1559 MHz – 1610 MHz

The following spectrum analyser setting are used for all steps:

- Measurement distance: 1 m
- Detector: RMS
- RBW: 1 kHz
- VBW: 3 kHz
- Measuring time: 1 ms / Sweep point
- Sweep Points: 1 / MHz [Span]

Step 1: Preliminary scan

Settings for step 1:

- Turntable angle range: -180° to 90°
- Turntable step size: 45°
- Elevation step size: 90°
- Polarisation: Horizontal + Vertical

Step 2: Adjustment measurement

In this step the accuracy of the turntable azimuth elevation will be improved. This is necessary to find out the maximum value of every frequency.

For each frequency, which was determined the turntable azimuth and elevation angle will be adjusted. The turntable azimuth will slowly vary by $\pm 22.5^{\circ}$ around this value. During this action, the value of emission is continuously measured. The turntable azimuth at the highest emission will be recorded and adjusted. In this position, the elevation angle will also slowly vary by $\pm 45^{\circ}$. During this action, the value of emission is also continuously measured. The elevation angle of the highest emission will also be recorded and adjusted.

- Turntable angle range: $\pm 22.5^{\circ}$ around the determined value
- Elevation angle range: $\pm 45^{\circ}$ around the determined value
- Antenna Polarisation: max. value determined in step 1

Step 3: Final measurement with RMS detector

With the settings determined in step 2, the final measurement will be performed.

The Test was performed radiated in a Fully Anechoic Chamber in the following setup:

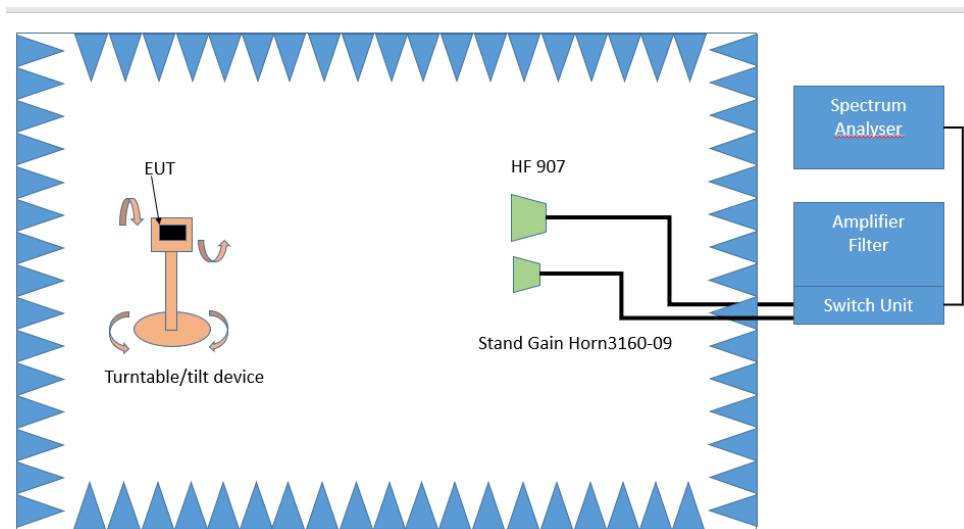

Test Setup; Spurious Emission Radiated (FAC), 1 GHz-26.5 GHz

4.4.2 TEST REQUIREMENTS / LIMITS

FCC Part 15, Subpart F, §15.519 (d)

In addition to the radiated emission limits specified in the table in paragraph (c) of this section, UWB transmitters operating under the provisions of this section shall not exceed the following average limits when measured using a resolution bandwidth of no less than 1 kHz:

Frequency in MHz	EIRP in dBm
1164 - 1240	-85.3
1559 - 1610	-85.3

RSS-220, 5.3.1 (e)

In addition to the limits specified in paragraph (d) of this section, radiated emissions shall not exceed the following average limits when measured using a resolution bandwidth greater than or equal to 1 kHz. The measurements shall demonstrate compliance with the stated limits at whatever resolution bandwidth is used.

Frequency in MHz	EIRP in dBm
1164 - 1240	-85.3
1559 - 1610	-85.3

4.4.3 TEST PROTOCOL

Ambient
temperature: 25 °C
Air Pressure: 1023 hPa
Humidity: 28 %

Operating Band: 3100 - 10600 MHz						
Operating Frequency	Spurious Freq. [MHz]	Spurious Level [dBm]	Detector	RBW [kHz]	Limit [dBm]	Margin to Limit [dB]
CH5_ANT1 OP-Mode 3	-	-	-	-	-85.3	-
CH6_ANT2 OP-Mode 4	-	-	-	-	-85.3	-
CH8_ANT2 OP-Mode 4	-	-	-	-	-85.3	-
CH9_ANT2 OP-Mode 3	-	-	-	-	-85.3	-

4.4.4 MEASUREMENT PLOT (SHOWING THE HIGHEST VALUE, "WORST CASE")

Measurement method = radiated, Channel = 5, Antenna 1, OP-mode 3
 Frequency range 1164 MHz -1240 MHz & 1559 MHz - 1610 MHz

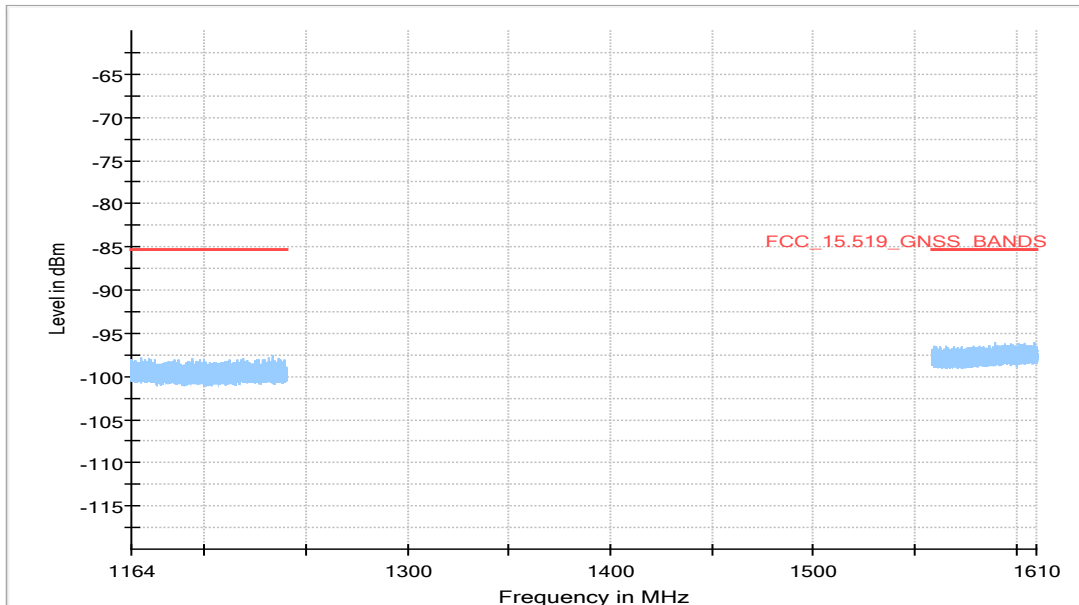

Measurement method = radiated, Channel = 6, Antenna 2, OP-mode 4
 Frequency range 1164 MHz -1240 MHz & 1559 MHz - 1610 MHz

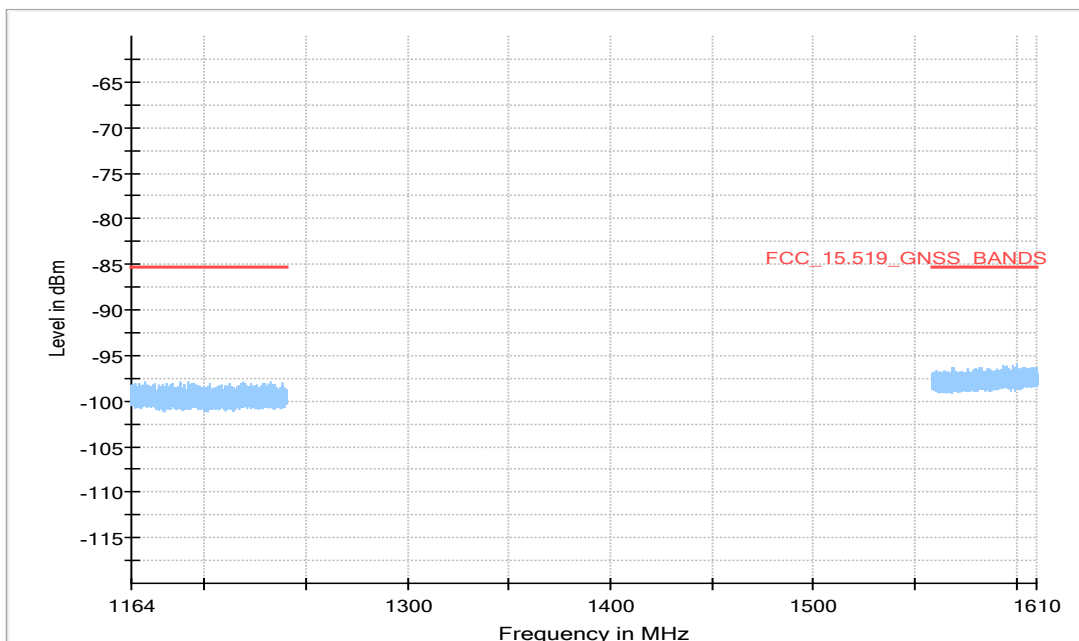

Measurement method = radiated, Channel = 8, Antenna 2, OP-mode 4
Frequency range 1164 MHz -1240 MHz & 1559 MHz - 1610 MHz

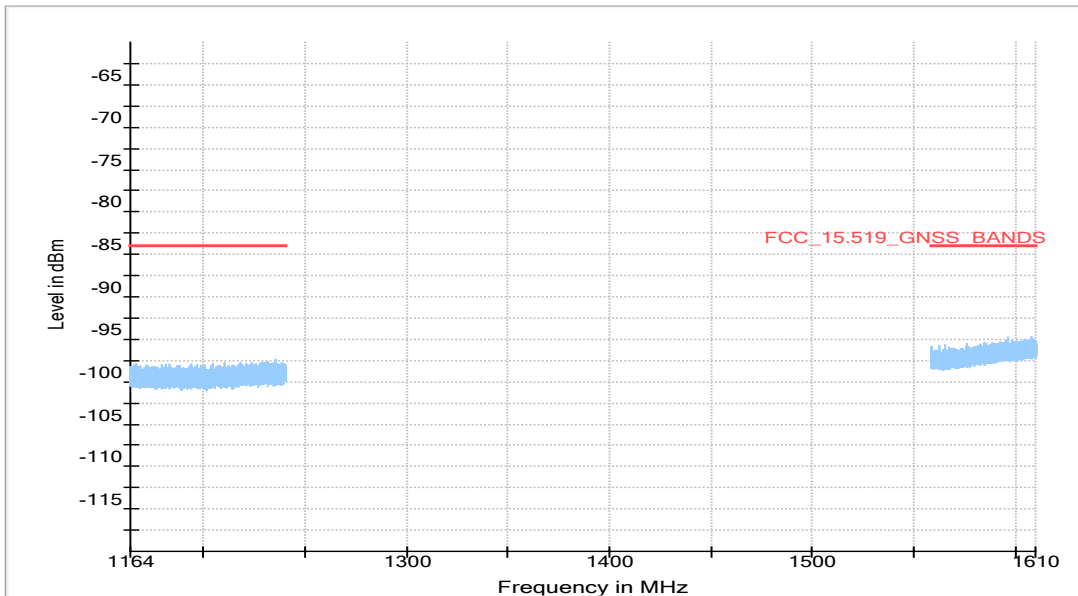

Measurement method = radiated, Channel = 9, Antenna 2, OP-mode 3
Frequency range 1164 MHz -1240 MHz & 1559 MHz - 1610 MHz

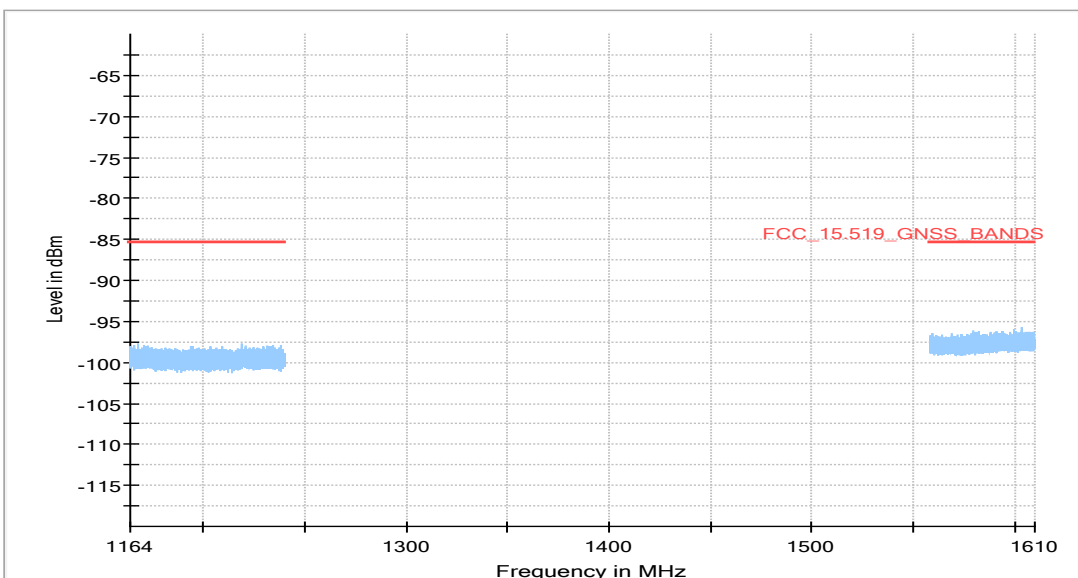

4.4.5 TEST EQUIPMENT USED

- Radiated Emissions

5 TEST EQUIPMENT

- 1 Radiated Emissions
Lab to perform radiated emission tests

Ref.No.	Device Name	Description	Manufacturer	Serial Number	Last Calibration	Calibration Due
1.1	N5000/NP	Filter for EUT, 2 Lines, 250 V, 16 A	ETS-LINDGREN	241515		
1.2	HL 562 ULTRALOG	Biconical-log-per antenna (30 MHz - 3 GHz) with HL 562E biconicals	Rohde & Schwarz GmbH & Co. KG	830547/003	2021-09	2024-09
1.3	AMF-7D00101800-30-10P-R	Broadband Amplifier 100 MHz - 18 GHz	Miteq			
1.4	5HC2700/12750-1.5-KK	High Pass Filter	Trilithic	9942012		
1.5	ASP 1.2/1.8-10 kg	Antenna Mast	Maturo GmbH	-		
1.6	Anechoic Chamber 03	FAR, 8.80m x 4.60m x 4.05m (l x w x h)	Albatross Projects	P26971-647-001-PRB	2021-04	2023-04
1.7	Fluke 177	Digital Multimeter 03 (Multimeter)	Fluke Europe B.V.	86670383	2020-04	2022-04
1.8	Opus10 THI (8152.00)	T/H Logger 10	Lufft Mess- und Regeltechnik GmbH	12488	2021-08	2023-08
1.9	PONTIS Con4101	PONTIS Camera Controller		6061510370		
1.10	NRVD	Power Meter	Rohde & Schwarz GmbH & Co. KG	828110/016	2021-09	2022-09
1.11	JS4-18002600-32-5P	Broadband Amplifier 18 GHz - 26 GHz	Miteq	849785		
1.12	FSW 43	Spectrum Analyzer	Rohde & Schwarz	103779	2021-06	2023-06
1.13	EP 1200/B, NA/B1	AC Source, Amplifier with integrated variable Oscillator	Spitzenberger & Spies GmbH & Co. KG	B6278		
1.14	3160-09	Standard Gain / Pyramidal Horn Antenna 26.5 GHz	EMCO Elektronik GmbH	00083069		
1.15	WHKX 7.0/18G-8SS	High Pass Filter	Wainwright Instruments GmbH	09		
1.16	DS 420S	Turn Table 2 m diameter	HD GmbH	420/573/99		
1.17	4HC1600/12750-1.5-KK	High Pass Filter	Trilithic	9942011		
1.18	JS4-00102600-42-5A	Broadband Amplifier 30 MHz - 26 GHz	Miteq	619368		

Ref.No.	Device Name	Description	Manufacturer	Serial Number	Last Calibration	Calibration Due
1.19	TT 1.5 WI	Turn Table	Maturo GmbH	-		
1.20	HL 562 ULTRALOG	Biconical-log- per Antenna (30 MHz - 3 GHz)	Rohde & Schwarz GmbH & Co. KG	100609	2019-05	2022-05
1.21	HF 906	Double-ridged horn	Rohde & Schwarz	357357/001	2021-08	2024-08
1.22	3160-10	Standard Gain / Pyramidal Horn Antenna 40 GHz	EMCO Electronic GmbH	00086675		
1.23	VLFX-650+	Low Pass Filter DC650 MHz	Mini-Circuits	15542		
1.24	JUN-AIR Mod. 6- 15	Air Compressor	JUN-AIR Deutschland GmbH	612582		
1.25	5HC3500/18000 -1.2-KK	High Pass Filter	Trilithic	200035008		
1.26	SB4- 100.OLD20- 3T/10 Airwin 2 x 1.5 kW	Air compressor (oil-free)	airWin Kompressoren UG	901/00503		
1.27	UNI-T UT195E	True RMS Digital Multimeter	UNI-T UNI-TREND TECHNOLOGY (CHINA) CO., LTD.	C190729561		
1.28	JS4-00101800- 35-5P	Broadband Amplifier 30 MHz - 18 GHz	Miteq	896037		
1.29	AS 620 P	Antenna Mast (pneumatic polarisation)	HD GmbH	620/37		
1.30	TD1.5-10kg	EUT Tilt Device (Rohacell)	Maturo GmbH	TD1.5- 10kg/024/37907 09		
1.31	NRV-Z1	Sensor Head B	Rohde & Schwarz GmbH & Co. KG	827753/006	2021-09	2022-09
1.32	HF 907-2	Double-ridged horn	Rohde & Schwarz	102817	2019-04	2022-04
1.33	PAS 2.5 - 10 kg	Antenna Mast	Maturo GmbH	-		
1.34	AFS42- 00101800-25-S- 42	Broadband Amplifier 25 MHz - 18 GHz	Miteq	2035324		
1.35	AM 4.0	Antenna Mast 4 m	Maturo GmbH	AM4.0/180/1192 0513		
1.36	HF 907	Double-ridged horn	Rohde & Schwarz	102444	2021-09	2024-09

The calibration interval is the time interval between "Last Calibration" and "Calibration Due"

6 ANTENNA FACTORS, CABLE LOSS AND SAMPLE CALCULATIONS

This chapter contains the antenna factors with their corresponding path loss of the used measurement path for all antennas as well as the insertion loss of the LISN.

6.1 LISN R&S ESH3-Z5 (150 KHZ – 30 MHZ)

Frequency MHz	Corr. dB	LISN insertion loss ESH3- Z5 dB	cable loss (incl. 10 dB atten- uator) dB
0.15	10.1	0.1	10.0
5	10.3	0.1	10.2
7	10.5	0.2	10.3
10	10.5	0.2	10.3
12	10.7	0.3	10.4
14	10.7	0.3	10.4
16	10.8	0.4	10.4
18	10.9	0.4	10.5
20	10.9	0.4	10.5
22	11.1	0.5	10.6
24	11.1	0.5	10.6
26	11.2	0.5	10.7
28	11.2	0.5	10.7
30	11.3	0.5	10.8

Sample calculation

$$U_{\text{LISN}} (\text{dB } \mu\text{V}) = U (\text{dB } \mu\text{V}) + \text{Corr. (dB)}$$

U = Receiver reading

LISN Insertion loss = Voltage Division Factor of LISN

Corr. = sum of single correction factors of used LISN, cables, switch units (if used)

Linear interpolation will be used for frequencies in between the values in the table.

6.2 ANTENNA R&S HFH2-Z2 (9 KHZ – 30 MHZ)

Frequency MHz	AF HFH-Z2) dB (1/m)	Corr. dB	cable loss 1 (inside chamber) dB	cable loss 2 (outside chamber) dB	cable loss 3 (switch unit) dB	cable loss 4 (to receiver) dB	distance corr. (-40 dB/ decade) dB	d _{Limit} (meas. distance (limit) m	d _{used} (meas. distance (used) m
0.009	20.50	-79.6	0.1	0.1	0.1	0.1	-80	300	3
0.01	20.45	-79.6	0.1	0.1	0.1	0.1	-80	300	3
0.015	20.37	-79.6	0.1	0.1	0.1	0.1	-80	300	3
0.02	20.36	-79.6	0.1	0.1	0.1	0.1	-80	300	3
0.025	20.38	-79.6	0.1	0.1	0.1	0.1	-80	300	3
0.03	20.32	-79.6	0.1	0.1	0.1	0.1	-80	300	3
0.05	20.35	-79.6	0.1	0.1	0.1	0.1	-80	300	3
0.08	20.30	-79.6	0.1	0.1	0.1	0.1	-80	300	3
0.1	20.20	-79.6	0.1	0.1	0.1	0.1	-80	300	3
0.2	20.17	-79.6	0.1	0.1	0.1	0.1	-80	300	3
0.3	20.14	-79.6	0.1	0.1	0.1	0.1	-80	300	3
0.49	20.12	-79.6	0.1	0.1	0.1	0.1	-80	300	3
0.490001	20.12	-39.6	0.1	0.1	0.1	0.1	-40	30	3
0.5	20.11	-39.6	0.1	0.1	0.1	0.1	-40	30	3
0.8	20.10	-39.6	0.1	0.1	0.1	0.1	-40	30	3
1	20.09	-39.6	0.1	0.1	0.1	0.1	-40	30	3
2	20.08	-39.6	0.1	0.1	0.1	0.1	-40	30	3
3	20.06	-39.6	0.1	0.1	0.1	0.1	-40	30	3
4	20.05	-39.5	0.2	0.1	0.1	0.1	-40	30	3
5	20.05	-39.5	0.2	0.1	0.1	0.1	-40	30	3
6	20.02	-39.5	0.2	0.1	0.1	0.1	-40	30	3
8	19.95	-39.5	0.2	0.1	0.1	0.1	-40	30	3
10	19.83	-39.4	0.2	0.1	0.2	0.1	-40	30	3
12	19.71	-39.4	0.2	0.1	0.2	0.1	-40	30	3
14	19.54	-39.4	0.2	0.1	0.2	0.1	-40	30	3
16	19.53	-39.3	0.3	0.1	0.2	0.1	-40	30	3
18	19.50	-39.3	0.3	0.1	0.2	0.1	-40	30	3
20	19.57	-39.3	0.3	0.1	0.2	0.1	-40	30	3
22	19.61	-39.3	0.3	0.1	0.2	0.1	-40	30	3
24	19.61	-39.3	0.3	0.1	0.2	0.1	-40	30	3
26	19.54	-39.3	0.3	0.1	0.2	0.1	-40	30	3
28	19.46	-39.2	0.3	0.1	0.3	0.1	-40	30	3
30	19.73	-39.1	0.4	0.1	0.3	0.1	-40	30	3

Sample calculation

$$E \text{ (dB } \mu\text{V/m)} = U \text{ (dB } \mu\text{V)} + AF \text{ (dB 1/m)} + Corr. \text{ (dB)}$$

U = Receiver reading

AF = Antenna factor

Corr. = sum of single correction factors of used cables, switch unit, distance correction, amplifier (if applicable)

distance correction = $-40 * \text{LOG} (d_{\text{Limit}} / d_{\text{used}})$

Linear interpolation will be used for frequencies in between the values in the table.

Table shows an extract of values

6.3 ANTENNA R&S HL562 (30 MHZ – 1 GHZ)

($d_{Limit} = 3\text{ m}$)

Frequency	AF R&S HL562	Corr.
MHz	dB (1/m)	dB
30	18.6	0.6
50	6.0	0.9
100	9.7	1.2
150	7.9	1.6
200	7.6	1.9
250	9.5	2.1
300	11.0	2.3
350	12.4	2.6
400	13.6	2.9
450	14.7	3.1
500	15.6	3.2
550	16.3	3.5
600	17.2	3.5
650	18.1	3.6
700	18.5	3.6
750	19.1	4.1
800	19.6	4.1
850	20.1	4.4
900	20.8	4.7
950	21.1	4.8
1000	21.6	4.9

cable loss 1 (inside chamber)	cable loss 2 (outside chamber)	cable loss 3 (switch unit)	cable loss 4 (to receiver)	distance corr. (-20 dB/ decade)	d_{Limit} (meas. distance (limit))	d_{used} (meas. distance (used))
dB	dB	dB	dB	dB	m	m
0.29	0.04	0.23	0.02	0.0	3	3
0.39	0.09	0.32	0.08	0.0	3	3
0.56	0.14	0.47	0.08	0.0	3	3
0.73	0.20	0.59	0.12	0.0	3	3
0.84	0.21	0.70	0.11	0.0	3	3
0.98	0.24	0.80	0.13	0.0	3	3
1.04	0.26	0.89	0.15	0.0	3	3
1.18	0.31	0.96	0.13	0.0	3	3
1.28	0.35	1.03	0.19	0.0	3	3
1.39	0.38	1.11	0.22	0.0	3	3
1.44	0.39	1.20	0.19	0.0	3	3
1.55	0.46	1.24	0.23	0.0	3	3
1.59	0.43	1.29	0.23	0.0	3	3
1.67	0.34	1.35	0.22	0.0	3	3
1.67	0.42	1.41	0.15	0.0	3	3
1.87	0.54	1.46	0.25	0.0	3	3
1.90	0.46	1.51	0.25	0.0	3	3
1.99	0.60	1.56	0.27	0.0	3	3
2.14	0.60	1.63	0.29	0.0	3	3
2.22	0.60	1.66	0.33	0.0	3	3
2.23	0.61	1.71	0.30	0.0	3	3

($d_{Limit} = 10\text{ m}$)

30	18.6	-9.9
50	6.0	-9.6
100	9.7	-9.2
150	7.9	-8.8
200	7.6	-8.6
250	9.5	-8.3
300	11.0	-8.1
350	12.4	-7.9
400	13.6	-7.6
450	14.7	-7.4
500	15.6	-7.2
550	16.3	-7.0
600	17.2	-6.9
650	18.1	-6.9
700	18.5	-6.8
750	19.1	-6.3
800	19.6	-6.3
850	20.1	-6.0
900	20.8	-5.8
950	21.1	-5.6
1000	21.6	-5.6

0.29	0.04	0.23	0.02	-10.5	10	3
0.39	0.09	0.32	0.08	-10.5	10	3
0.56	0.14	0.47	0.08	-10.5	10	3
0.73	0.20	0.59	0.12	-10.5	10	3
0.84	0.21	0.70	0.11	-10.5	10	3
0.98	0.24	0.80	0.13	-10.5	10	3
1.04	0.26	0.89	0.15	-10.5	10	3
1.18	0.31	0.96	0.13	-10.5	10	3
1.28	0.35	1.03	0.19	-10.5	10	3
1.39	0.38	1.11	0.22	-10.5	10	3
1.44	0.39	1.20	0.19	-10.5	10	3
1.55	0.46	1.24	0.23	-10.5	10	3
1.59	0.43	1.29	0.23	-10.5	10	3
1.67	0.34	1.35	0.22	-10.5	10	3
1.67	0.42	1.41	0.15	-10.5	10	3
1.87	0.54	1.46	0.25	-10.5	10	3
1.90	0.46	1.51	0.25	-10.5	10	3
1.99	0.60	1.56	0.27	-10.5	10	3
2.14	0.60	1.63	0.29	-10.5	10	3
2.22	0.60	1.66	0.33	-10.5	10	3
2.23	0.61	1.71	0.30	-10.5	10	3

Sample calculation

$$E \text{ (dB } \mu\text{V/m)} = U \text{ (dB } \mu\text{V)} + \text{AF (dB 1/m)} + \text{Corr. (dB)}$$

U = Receiver reading

AF = Antenna factor

Corr. = sum of single correction factors of used cables, switch unit, distance correction, amplifier (if applicable)

distance correction = $-20 * \text{LOG} (d_{Limit} / d_{used})$

Linear interpolation will be used for frequencies in between the values in the table.

Tables show an extract of values.

6.4 ANTENNA R&S HF907 (1 GHZ – 18 GHZ)

Frequency MHz	AF R&S HF907 dB (1/m)	Corr. dB
1000	24.4	-19.4
2000	28.5	-17.4
3000	31.0	-16.1
4000	33.1	-14.7
5000	34.4	-13.7
6000	34.7	-12.7
7000	35.6	-11.0

cable loss 1 (relay + cable inside chamber) dB	cable loss 2 (outside chamber) dB	cable loss 3 (switch unit, atten- uator & pre-amp) dB	cable loss 4 (to receiver) dB
0.99	0.31	-21.51	0.79
1.44	0.44	-20.63	1.38
1.87	0.53	-19.85	1.33
2.41	0.67	-19.13	1.31
2.78	0.86	-18.71	1.40
2.74	0.90	-17.83	1.47
2.82	0.86	-16.19	1.46

Frequency MHz	AF R&S HF907 dB (1/m)	Corr. dB
3000	31.0	-23.4
4000	33.1	-23.3
5000	34.4	-21.7
6000	34.7	-21.2
7000	35.6	-19.8

cable loss 1 (relay inside chamber) dB	cable loss 2 (inside chamber) dB	cable loss 3 (outside chamber) dB	cable loss 4 (switch unit, atten- uator & pre-amp) dB	cable loss 5 (to receiver) dB	used for FCC 15.247
0.47	1.87	0.53	-27.58	1.33	
0.56	2.41	0.67	-28.23	1.31	
0.61	2.78	0.86	-27.35	1.40	
0.58	2.74	0.90	-26.89	1.47	
0.66	2.82	0.86	-25.58	1.46	

Frequency MHz	AF R&S HF907 dB (1/m)	Corr. dB
7000	35.6	-57.3
8000	36.3	-56.3
9000	37.1	-55.3
10000	37.5	-56.2
11000	37.5	-55.3
12000	37.6	-53.7
13000	38.2	-53.5
14000	39.9	-56.3
15000	40.9	-54.1
16000	41.3	-54.1
17000	42.8	-54.4
18000	44.2	-54.7

cable loss 1 (relay inside chamber) dB	cable loss 2 (High Pass) dB	cable loss 3 (pre- amp) dB	cable loss 4 (inside chamber) dB	cable loss 5 (outside chamber) dB	cable loss 6 (to receiver) dB
0.56	1.28	-62.72	2.66	0.94	1.46
0.69	0.71	-61.49	2.84	1.00	1.53
0.68	0.65	-60.80	3.06	1.09	1.60
0.70	0.54	-61.91	3.28	1.20	1.67
0.80	0.61	-61.40	3.43	1.27	1.70
0.84	0.42	-59.70	3.53	1.26	1.73
0.83	0.44	-59.81	3.75	1.32	1.83
0.91	0.53	-63.03	3.91	1.40	1.77
0.98	0.54	-61.05	4.02	1.44	1.83
1.23	0.49	-61.51	4.17	1.51	1.85
1.36	0.76	-62.36	4.34	1.53	2.00
1.70	0.53	-62.88	4.41	1.55	1.91

Sample calculation

$$E \text{ (dB } \mu\text{V/m)} = U \text{ (dB } \mu\text{V)} + \text{AF (dB 1/m)} + \text{Corr. (dB)}$$

U = Receiver reading

AF = Antenna factor

Corr. = sum of single correction factors of used cables, switch unit, distance correction, amplifier (if applicable)

Linear interpolation will be used for frequencies in between the values in the table.

Tables show an extract of values.

6.5 ANTENNA EMCO 3160-09 (18 GHZ – 26.5 GHZ)

Frequency MHz	AF EMCO 3160-09 dB (1/m)	Corr. dB	cable loss 1 (inside chamber) dB	cable loss 2 (pre- amp) dB	cable loss 3 (inside chamber) dB	cable loss 4 (switch unit) dB	cable loss 5 (to receiver) dB
18000	40.2	-23.5	0.72	-35.85	6.20	2.81	2.65
18500	40.2	-23.2	0.69	-35.71	6.46	2.76	2.59
19000	40.2	-22.0	0.76	-35.44	6.69	3.15	2.79
19500	40.3	-21.3	0.74	-35.07	7.04	3.11	2.91
20000	40.3	-20.3	0.72	-34.49	7.30	3.07	3.05
20500	40.3	-19.9	0.78	-34.46	7.48	3.12	3.15
21000	40.3	-19.1	0.87	-34.07	7.61	3.20	3.33
21500	40.3	-19.1	0.90	-33.96	7.47	3.28	3.19
22000	40.3	-18.7	0.89	-33.57	7.34	3.35	3.28
22500	40.4	-19.0	0.87	-33.66	7.06	3.75	2.94
23000	40.4	-19.5	0.88	-33.75	6.92	3.77	2.70
23500	40.4	-19.3	0.90	-33.35	6.99	3.52	2.66
24000	40.4	-19.8	0.88	-33.99	6.88	3.88	2.58
24500	40.4	-19.5	0.91	-33.89	7.01	3.93	2.51
25000	40.4	-19.3	0.88	-33.00	6.72	3.96	2.14
25500	40.5	-20.4	0.89	-34.07	6.90	3.66	2.22
26000	40.5	-21.3	0.86	-35.11	7.02	3.69	2.28
26500	40.5	-21.1	0.90	-35.20	7.15	3.91	2.36

Sample calculation

$$E \text{ (dB } \mu\text{V/m)} = U \text{ (dB } \mu\text{V)} + \text{AF (dB 1/m)} + \text{Corr. (dB)}$$

U = Receiver reading

AF = Antenna factor

Corr. = sum of single correction factors of used cables, switch unit, distance correction, amplifier (if applicable)

Linear interpolation will be used for frequencies in between the values in the table.

Table shows an extract of values.

6.6 ANTENNA EMCO 3160-10 (26.5 GHZ – 40 GHZ)

Frequency GHz	AF EMCO 3160-10 dB (1/m)	Corr. dB	cable loss 1 (inside chamber) dB	cable loss 2 (outside chamber) dB	cable loss 3 (switch unit) dB	cable loss 4 (to receiver) dB	distance corr. (-20 dB/ decade) dB	d _{Limit} (meas. distance (limit) m	d _{used} (meas. distance (used) m
26.5	43.4	-11.2	4.4				-15.6	3	0.5
27.0	43.4	-11.2	4.4				-15.6	3	0.5
28.0	43.4	-11.1	4.5				-15.6	3	0.5
29.0	43.5	-11.0	4.6				-15.6	3	0.5
30.0	43.5	-10.9	4.7				-15.6	3	0.5
31.0	43.5	-10.8	4.7				-15.6	3	0.5
32.0	43.5	-10.7	4.8				-15.6	3	0.5
33.0	43.6	-10.7	4.9				-15.6	3	0.5
34.0	43.6	-10.6	5.0				-15.6	3	0.5
35.0	43.6	-10.5	5.1				-15.6	3	0.5
36.0	43.6	-10.4	5.1				-15.6	3	0.5
37.0	43.7	-10.3	5.2				-15.6	3	0.5
38.0	43.7	-10.2	5.3				-15.6	3	0.5
39.0	43.7	-10.2	5.4				-15.6	3	0.5
40.0	43.8	-10.1	5.5				-15.6	3	0.5

Sample calculation

$$E \text{ (dB } \mu\text{V/m)} = U \text{ (dB } \mu\text{V)} + AF \text{ (dB 1/m)} + Corr. \text{ (dB)}$$

U = Receiver reading

AF = Antenna factor

Corr. = sum of single correction factors of used cables, switch unit, distance correction, amplifier (if applicable)

Linear interpolation will be used for frequencies in between the values in the table.

distance correction = $-20 * \text{LOG} (d_{\text{Limit}} / d_{\text{used}})$

Linear interpolation will be used for frequencies in between the values in the table.

Table shows an extract of values.

7 SETUP DRAWINGS

Setup Drawings

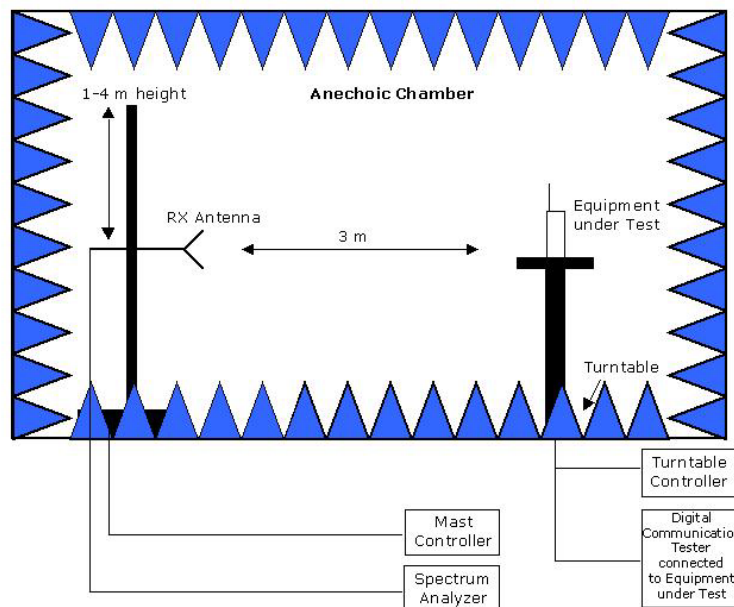

Remark: Depending on the frequency range suitable antenna types, attenuators or preamplifiers are used.

Setup in the Anechoic chamber. For measurements below 1 GHz the ground was replaced by a conducting ground plane.

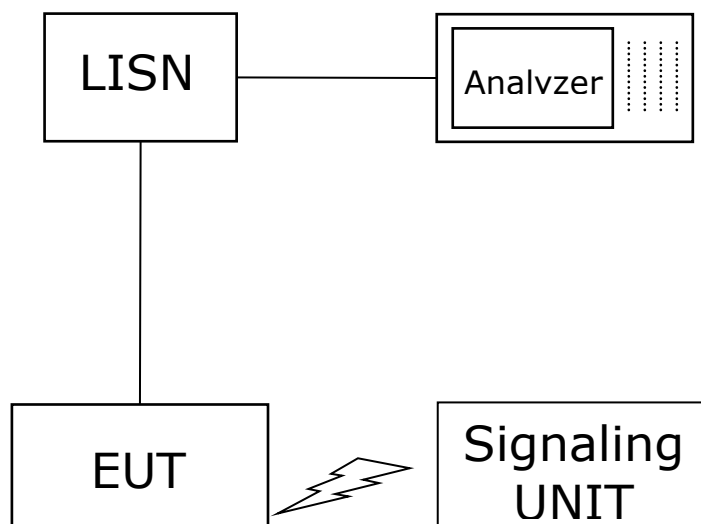

Setup in the shielded room for conducted measurements at AC mains port

8 MEASUREMENT UNCERTAINTIES

Test Case	Parameter	Uncertainty
Conducted Emissions at AC mains	Voltage	± 3.4 dB
Radiated Emissions	Field Strength	± 5.5 dB

The measurement uncertainties for all parameters are calculated with an expansion factor (coverage factor) $k = 1.96$. This means, that the true value is in the corresponding interval with a probability of 95 %.

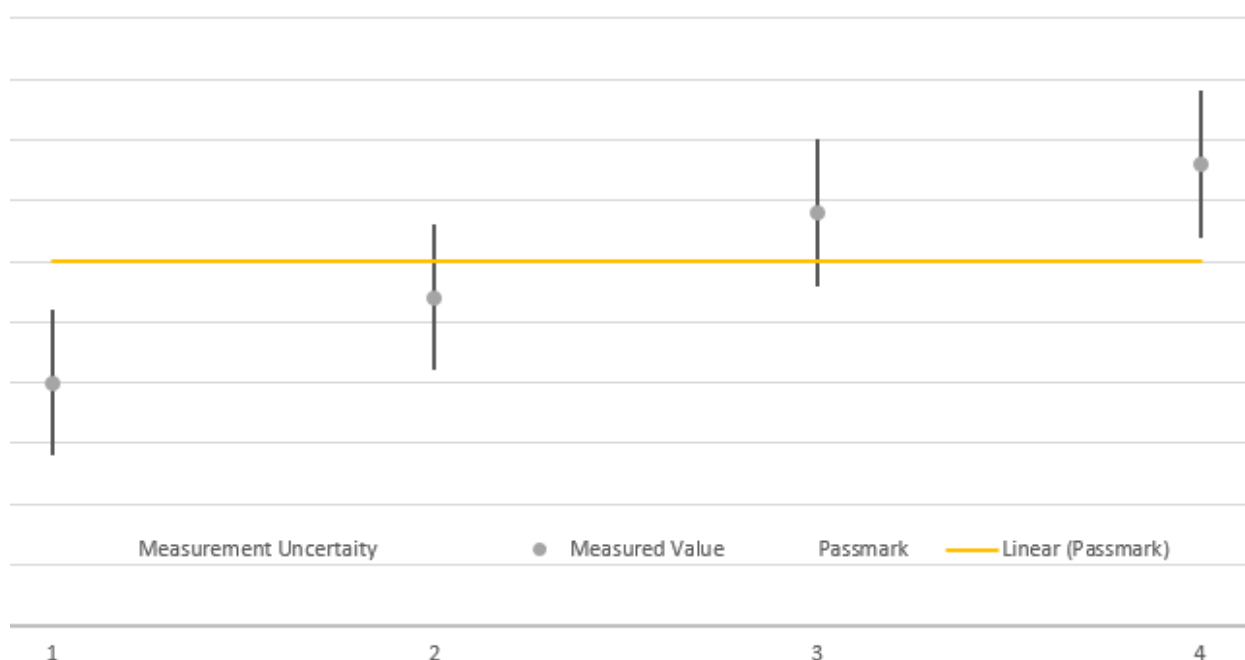

The verdicts in this test report are given according the above diagram:

Case	Measured Value	Uncertainty Range	Verdict
1	below pass mark	below pass mark	Passed
2	below pass mark	within pass mark	Passed
3	above pass mark	within pass mark	Failed
4	above pass mark	above pass mark	Failed

That means, the laboratory applies, as decision rule (see ISO/IEC 17025:2017), the so called shared risk principle.

9 PHOTO REPORT

Please see separate photo report.