



Willow Run Test Labs, LLC
8501 Beck Road, Building 2227
Belleville, Michigan 48111 USA
Tel: (734) 252-9785
Fax: (734) 926-9785
e-mail: info@wrtest.com

Testing of
Electromagnetic Emissions

per

USA: CFR Title 47, Part 15.109
Canada: IC RSS-310/GEN

are herein reported for

Lear Corporation
290MG1

Test Report No.: 20160203-RPTWAC010016Ar0
Copyright © 2016

Applicant/Provider:
Lear Corporation
21557 Telegraph Road Building 100, Southfield Michigan 48033 USA
Phone: +1 (248) 447-1357, Fax: +1 (248) 447-1683
Contact Person: Jason Summerford; jssummerford@lear.com

Measured by: Joseph Brunett Report Approved by: Joseph Brunett
Dr. Joseph Brunett, EMC-002790-NE Dr. Joseph Brunett, EMC-002790-NE
Report by: Joseph Brunett Report Date of Issue: February 3, 2016
Dr. Joseph Brunett, EMC-002790-NE

Results of testing completed on (or before) February 2, 2016 are as follows.

Emissions: Radiated spurious emissions associated with the receive chain of this device **COMPLY** the regulatory limit(s) by no less than 14.5 dB.

Contents

1	Test Specifications, General Procedures, and Location	4
1.1	Test Specification and General Procedures	4
1.2	Test Location and Equipment Used	5
2	Configuration and Identification of the Equipment Under Test	6
2.1	Description and Declarations	6
2.1.1	EUT Configuration	6
2.1.2	Modes of Operation	6
2.1.3	Variants	6
2.1.4	Test Samples	6
2.1.5	Functional Exerciser	7
2.1.6	Modifications Made	7
2.1.7	Production Intent	7
2.1.8	Declared Exemptions and Additional Product Notes	7
3	Emissions	8
3.1	General Test Procedures	8
3.1.1	Radiated Test Setup and Procedures	8
3.1.2	Conducted Emissions Test Setup and Procedures	10
3.1.3	Power Supply Variation	10
3.1.4	Thermal Variation	10
3.2	Unintentional Emissions	11
3.2.1	Radiated Receiver Spurious	11

List of Tables

1	Willow Run Test Labs, LLC Equipment List	5
2	EUT Declarations.	6
3	Receiver Chain Spurious Emissions \geq 30 MHz.	11

List of Figures

1	Photos of EUT.	6
2	EUT Test Configuration Diagram.	7
3	Radiated Emissions Diagram of the EUT.	8
4	Radiated Emissions Test Setup Photograph(s).	9

1 Test Specifications, General Procedures, and Location

1.1 Test Specification and General Procedures

The ultimate goal of Lear Corporation is to demonstrate that the Equipment Under Test (EUT) complies with the Rules and/or Directives below. Detailed in this report are the results of testing the Lear Corporation 290MG1 for compliance to:

Country/Region	Rules or Directive	Referenced Section(s)
United States	Code of Federal Regulations	CFR Title 47, Part 15.109
Canada	Industry Canada	IC RSS-310/GEN

Lear Corporation has determined that the equipment under test is subject to the rules and directives above at the date of this testing. In conjunction with these rules and directives, the following specifications and procedures are followed herein to demonstrate compliance (in whole or in part) with these regulations.

ANSI C63.4:2014	"Methods of Measurement of Radio-Noise Emissions from Low-Voltage Electrical and Electronic Equipment in the Range of 9 kHz to 40 GHz"
ANSI C63.10:2013 (USA)	"American National Standard of Procedures for Compliance Testing of Unlicensed Wireless Devices"

1.2 Test Location and Equipment Used

Test Location The EUT was fully tested by **Willow Run Test Labs, LLC**, 8501 Beck Road, Building 2227, Belleville, Michigan 48111 USA. The Test Facility description and attenuation characteristics are on file with the FCC Laboratory, Columbia, Maryland (FCC Reg. No: 688478) and with Industry Canada, Ottawa, ON (File Ref. No: IC 8719A-1).

Test Equipment Pertinent test equipment used for measurements at this facility is listed in Table 1. The quality system employed at Willow Run Test Labs, LLC has been established to ensure all equipment has a clearly identifiable classification, calibration expiry date, and that all calibrations are traceable to the SI through NIST, other recognized national laboratories, accepted fundamental or natural physical constants, ratio type of calibration, or by comparison to consensus standards.

Table 1: Willow Run Test Labs, LLC Equipment List

Description	Manufacturer/Model	SN	Quality Num.	Last Cal By / Date Due
Spectrum Analyzer	Rhode-Schwarz / FSV30	101660	RSFSV30001	RS / Apr-2016
Log Periodic Antenna	EMCO / 3146	9305-3614	LOGEMCO01	Lib. Labs/ April-2016
Quad Ridge Horn	ETS Lind. / 3164-04	00066988	HRNQR316401	Lib. Labs / Apr-2016
Quad Ridge Horn	Singer / A6100	C35200	HQR2TO18S01	Lib. Labs / Apr-2016

2 Configuration and Identification of the Equipment Under Test

2.1 Description and Declarations

The equipment under test is an automotive Remote Keyless Entry receiver. The EUT is approximately 5 x 8 x 2 cm in dimension, and is depicted in Figure 1. It is powered by a 12 VDC vehicle power system. In use, this device is permanently installed in a motor vehicle. Table 2 outlines provider declared EUT specifications.

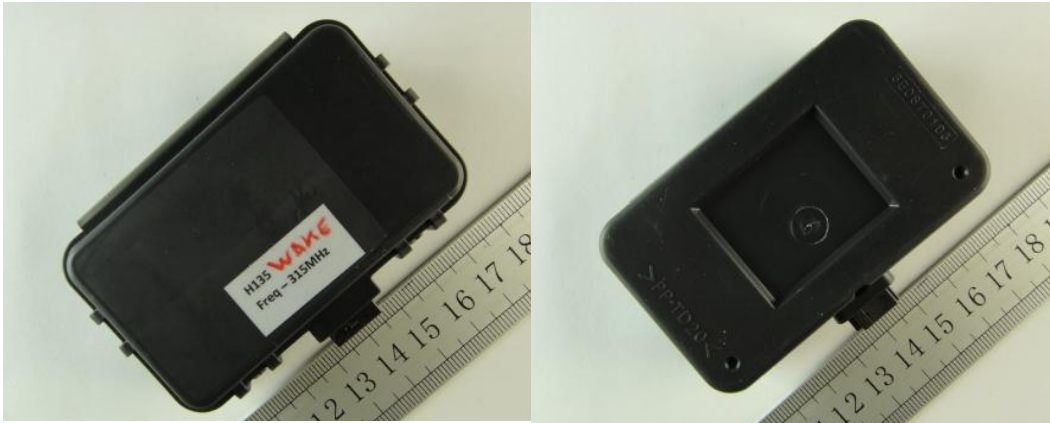

Figure 1: Photos of EUT.

Table 2: EUT Declarations.

General Declarations			
Equipment Type:	Receiver	Country of Origin:	Not Declared
Nominal Supply:	12 VDC	Oper. Temp Range:	-40°C to +85°C
Frequency Range:	315 MHz	Antenna Dimension:	80 mm
Antenna Type:	metal frame (integral)	Antenna Gain:	Not Declared
United States			
FCC ID Number:	KOBLR17A	Classification:	CYY
Canada			
IC Number:	CAN RSS-GEN/CNR-GEN	Classification:	Cat II Rx

2.1.1 EUT Configuration

The EUT is configured for testing as depicted in Figure 2.

2.1.2 Modes of Operation

There is only a single mode of operation for this device, as a receiver.

2.1.3 Variants

There is only a single variant of the EUT, as tested.

2.1.4 Test Samples

One sample of the EUT was provided for testing. Its software was modified by the manufacturer to keep the receiver awake whenever power is applied.

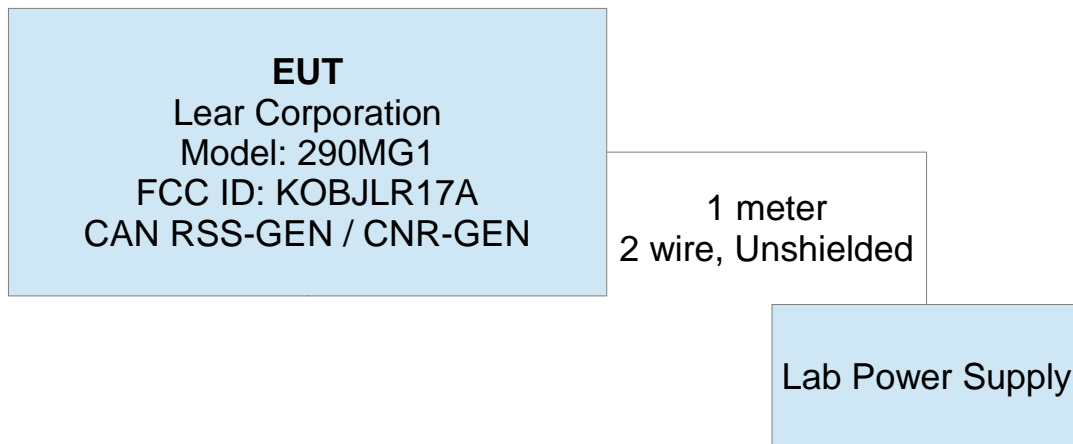

Figure 2: EUT Test Configuration Diagram.

2.1.5 Functional Exerciser

EUT functionality was verified by observation of transmitted signal.

2.1.6 Modifications Made

There were no modifications made to the EUT by this laboratory.

2.1.7 Production Intent

The EUT appears to be a production ready sample.

2.1.8 Declared Exemptions and Additional Product Notes

The EUT is permanently installed in a transportation vehicle. As such, digital emissions are exempt from US and Canadian digital emissions regulations (per FCC 15.103(a) and IC correspondence on ICES-003). This radio is considered a Category II receiver for Industry Canada, subject to verification under RSS-310/GEN.

3 Emissions

3.1 General Test Procedures

3.1.1 Radiated Test Setup and Procedures

Radiated electromagnetic emissions from the EUT are first pre-scanned in our shielded anechoic chamber. Spectrum and modulation characteristics of all emissions are recorded. Instrumentation, including spectrum analyzers and other test equipment as detailed in Section 1.2 are employed. After indoor pre-scans, emission measurements are made on our outdoor 3-meter Open Area Test Site (OATS). If the EUT connects to auxiliary equipment and is table or floor standing, the configurations prescribed in relevant test standards are followed. Alternatively, a layout closest to normal use (as declared by the provider) is employed if the resulting emissions appear to be worst-case in such a configuration. See Figure 3. All intentionally radiating elements that are not fixed-mounted in use are placed on the test table lying flat, on their side, and on their end (3-axes) and the resulting worst case emissions are recorded. If the EUT is fixed-mounted in use, measurements are made with the device oriented in the manner consistent with installation and then emissions are recorded.

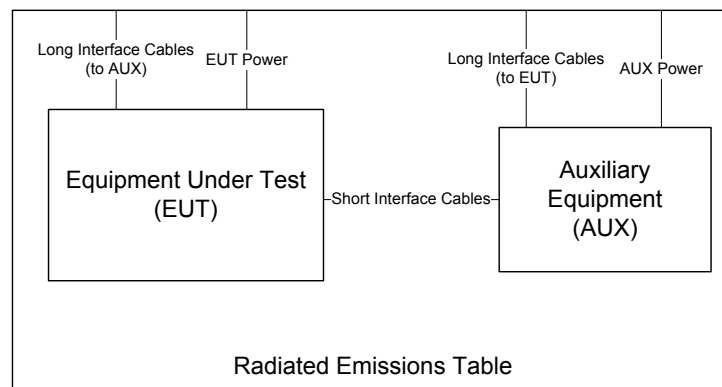

Figure 3: Radiated Emissions Diagram of the EUT.

If the EUT exhibits spurious emissions due to internal receiver circuitry, such emissions are measured with an appropriate carrier signal applied. For devices with intentional emissions below 30 MHz, a shielded loop antenna is used. It is placed at a 1 meter receive height. Emissions between 30 MHz and 1 GHz are measured using tuned dipoles and/or calibrated broadband antennas. For both horizontal and vertical polarizations, the test antenna is raised and lowered from 1 to 4 m in height until a maximum emission level is detected. The EUT is then rotated through 360° in azimuth until the highest emission is detected. The test antenna is then raised and lowered one last time from 1 to 4 m and the worst case value is recorded. Emissions above 1 GHz are characterized using standard gain horn antennas or calibrated broadband ridge-horn antennas on our OATS with a 4×5 m rectangle of AN-79 and/or H-4 absorber placed over the ground screen covering the OATS ground screen. Care is taken to ensure that test receiver resolution and video bandwidths meet the regulatory requirements, and that the emission bandwidth of the EUT is not reduced. Photographs of the test setup employed are depicted in Figure 4.

Where regulations allow for direct measurement of field strength, power values (dBm) measured on the test receiver / analyzer are converted to $\text{dB}\mu\text{V}/\text{m}$ at the regulatory distance, using

$$E_{dist} = 107 + P_R + K_A - K_G + K_E - C_F$$

where P_R is the power recorded on spectrum analyzer, in dBm, K_A is the test antenna factor in dB/m, K_G is the combined pre-amplifier gain and cable loss in dB, K_E is duty correction factor (when applicable) in dB, and C_F is a distance conversion (employed only if limits are specified at alternate distance) in dB. This field strength value is then compared with the regulatory limit. If effective isotropic radiated power (EIRP) is computed, it is computed as

$$EIRP(\text{dBm}) = E_{3m}(\text{dB}\mu\text{V}/\text{m}) - 95.2.$$

When presenting data at each frequency, the highest measured emission under all possible EUT orientations (3-axes) is reported.



Figure 4: Radiated Emissions Test Setup Photograph(s).

3.1.2 Conducted Emissions Test Setup and Procedures

Vehicle Power Conducted Spurious The EUT is not subject to power line conducted emissions regulations as it is powered solely by the vehicle power system for use in said motor vehicle.

3.1.3 Power Supply Variation

Tests at extreme supply voltages are made if required by the the procedures specified in the test standard, and results of this testing are detailed in this report.

3.1.4 Thermal Variation

Tests at extreme temperatures are made if required by the procedures specified in the test standard, and results of this testing are detailed in this report. The provider has declared that the EUT is designed for operation over the temperature range -40°C to $+85^{\circ}\text{C}$. Before any temperature measurements are made, the equipment is allowed to reach a thermal balance in the test chamber, temperature and humidity are recorded, and thermal balance is verified via a thermocouple-based probe.

3.2 Unintentional Emissions

3.2.1 Radiated Receiver Spurious

The results for the measurement of radiated receiver spurious emissions (emissions arising from the receiver chain, e.g. LO or VCO) at the nominal voltage and temperature are reported in Table 3. Receive chain emissions are measured to 5 times the highest receive chain frequency employed or 4 GHz, whichever is higher. If no emissions are detected, only those noise floor emissions at the LO/VCO frequency are reported.

Table 3: Receiver Chain Spurious Emissions \geq 30 MHz.

Frequency Range	Det	IF Bandwidth	Video Bandwidth	Test Date:	21-Jan-16
25 MHz f 1 000 MHz	Pk/QPk	120 kHz	300 kHz	Test Engineer:	Joseph Brunett
f > 1 000 MHz	Pk/Avg	1 MHz	3 MHz	EUT:	Lear Rx
				Mode:	Awake
				Meas. Distance:	3m

Receiver Spurious																			
#	Frequency Band		Test Antenna + Cable				Rx. Power*			Distance			E-Field**		EIRP		E-Field Limit	Pass By	Comments
	Start MHz	Stop MHz	Type/Asset	Pol. H/V	Ka dB/m	Kg dB	Peak dBm	Qpk/Avg dBm	Meas. m	Des. m	CF dB	Pk dBuV/m	Avg/QPk dBuV/m	Pk dBm	Avg dBm	FCC dBuV/m			
1	304.3	304.3	LOGEMCO01	V	14.8	33.9	-68.3		3.0	3.0	.0	19.6				46.0	26.4	noise	
2	608.6	608.6	LOGEMCO01	H	19.3	30.7	-69.3		3.0	3.0	.0	26.4				46.0	19.6	background	
3	1000.0	4500.0	HRNQR316401	H/V	33.0	-0.5	-101.0		4.0	4.0	.0	39.5				54.0	14.5	noise	
4	3600.0	3600.0	HRNQR316401	H/V	35.4	-0.4	-105.0		5.0	5.0	.0	37.8				54.0	16.2	noise	
5	4500.0	18000.0	HQR2TO18S01	H/V	34.3	-1.6	-107.0		6.0	6.0	.0	35.9				54.0	18.1	noise	
6																			
7																			
8																			
9																			
10																			
11																			
12																			
13																			

*QPk detection below 1 GHz, Avg detection at or above 1 GHz with receiver bandwidth as specified at top of table.
 ** When E-field is reported directly from Spectrum Analyzer, Antenna Factors and Cable losses are included directly in SA settings.