

# Super-Heterodyne Receiver

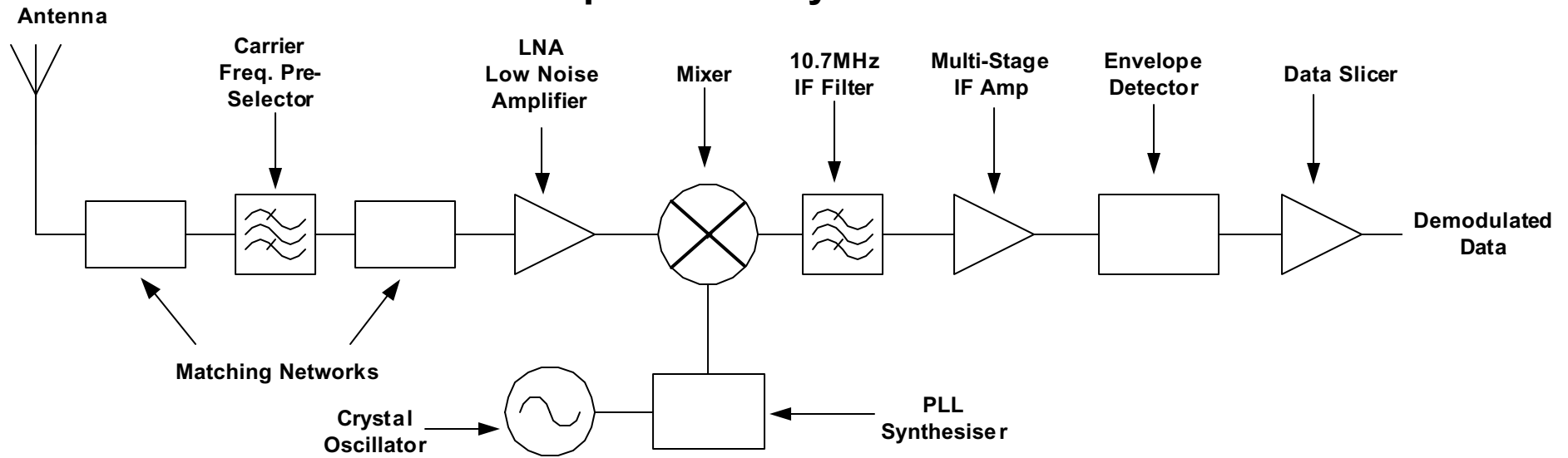

Block	Purpose	Example
Antenna	Capture radiated RF energy and couple energy into receiver front end.	PCB trace, Rigid wire, External wire
Frequency Pre-Selector	Suppress image frequency and out of band jamming sources.	SAW (Surface Acoustic Wave) Filter.
Matching Networks	Transfer maximum energy between the different stages	LC network, Integrated filter components.
Low Noise Amplifier	Provide RF signal amplification with minimum noise.	Cascode Amplifier.
Mixer	Convert the input frequency (RF) to an intermediate frequency (IF).	Double Balanced Mixer
IF Filter	Set System Bandwidth	Ceramic, LC networks.
IF Cascaded Amplifiers	Provide IF signal amplification	Cascode Amplifiers
Envelope Detector	Convert IF frequency to DC voltage levels.	Diode detector with low pass filter.
Data Slicer	Condition demodulated data to logic levels for microprocessor decoding.	Operational Amplifiers using RC timing components