

Re: Certification for Lear Corporation  
Receiver, Model SKREEM  
FCC ID: KOBDR04A, KOBDR04B  
IC: 3521A-R04B, 3521A-R04C

## Receiver Block Diagram

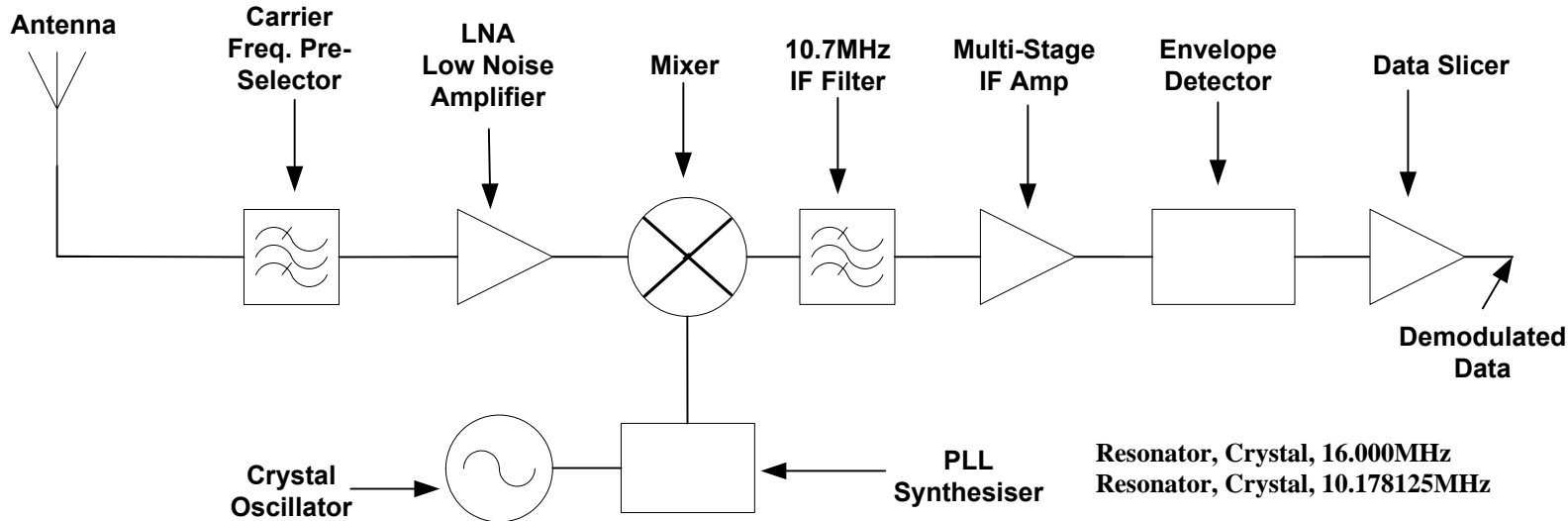

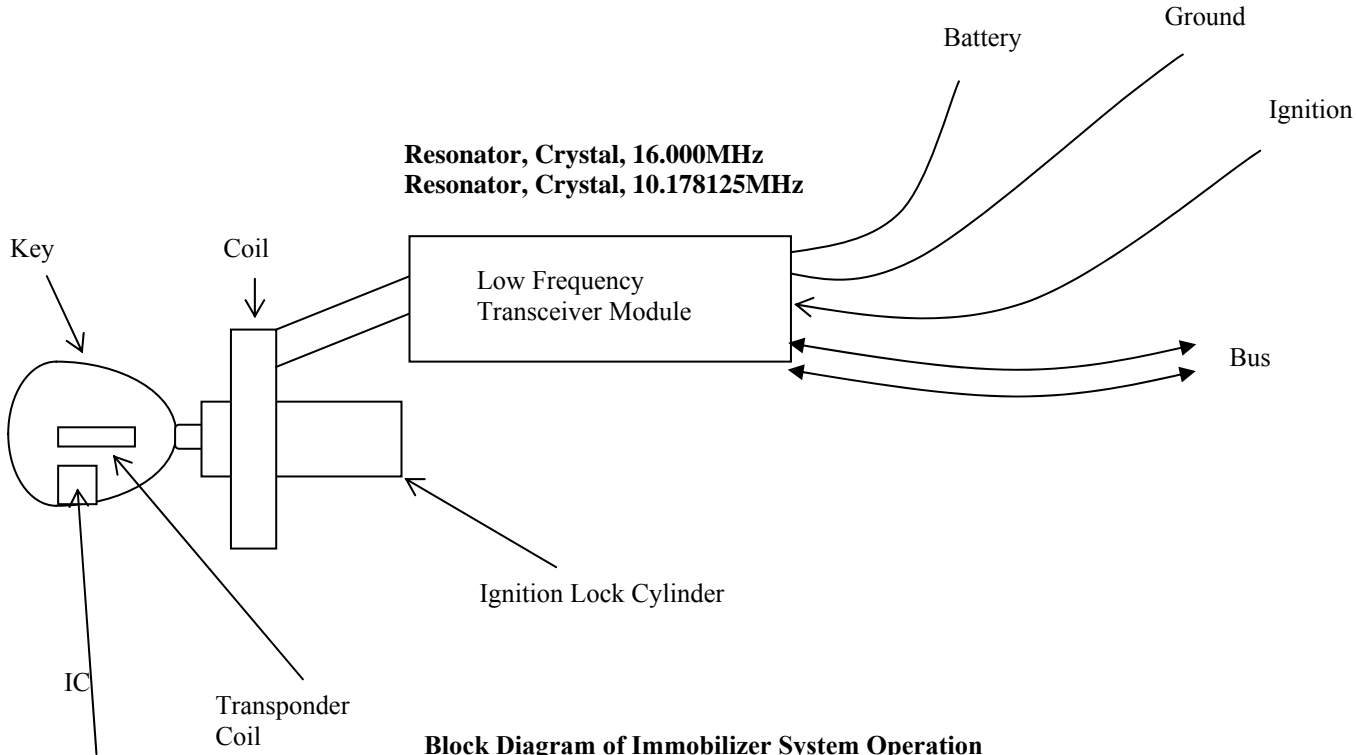

**Block Diagram of Immobilizer System Operation**