

8 7 6 5 4 3 2 1

| REVISIONS | | | | |
|-----------|------|-------------|--------|----------|
| ZONE | REV. | DESCRIPTION | DATE | APPROVED |
| | 000 | DRAFT | 9/3/15 | CS |

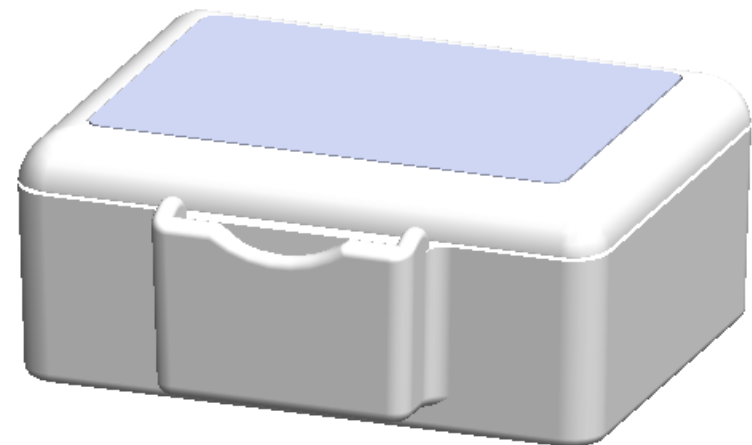
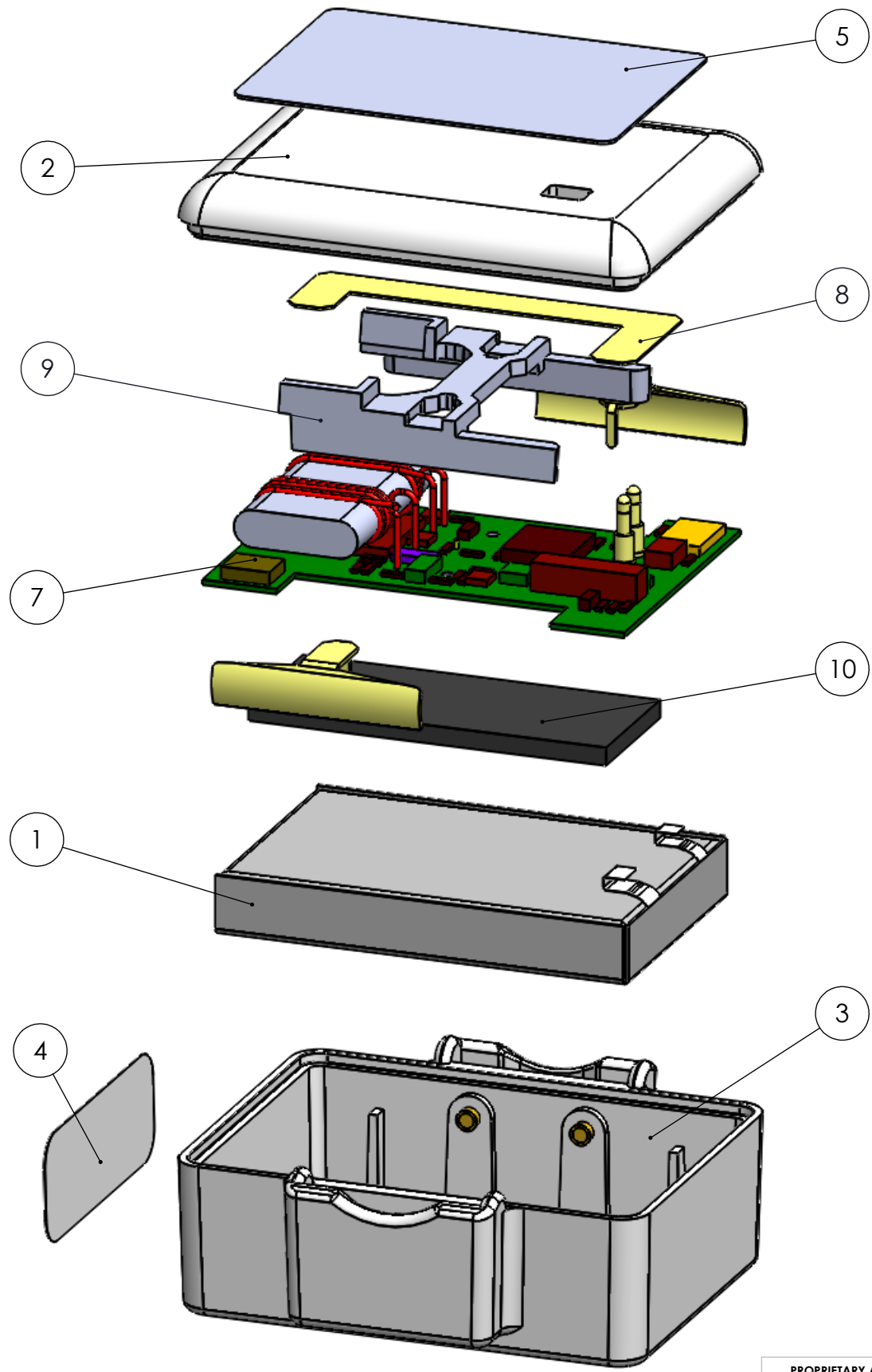

FCC LABEL TO BE PLACE ON THE SIDE OF THE TRANSMITTER AS SHOWN

| ITEM NO. | DESCRIPTION | QTY. |
|----------|--|------|
| 1 | 3.0V THIN CELL BATTERY | 1 |
| 2 | NON-RTLS TRANSMITTER COVER | 1 |
| 3 | TRANSMITTER BASE | 1 |
| 4 | FCC BARCODE LABEL | 1 |
| 5 | TOP LABEL | 1 |
| 6 | INNER CUTBAND CONTACT | 2 |
| 7 | SMART TRANSMITTER CONTROL BOARD ASSEMBLY | 1 |
| 8 | COPPER FOIL ANTENNA | 1 |
| 9 | ANTENNA POSITIONING CRADLE | 1 |
| 10 | BLACK FOAM | 1 |
| 11 | PACKAGING | 1 |
| 12 | FCC LABEL | 1 |

PROPRIETARY AND CONFIDENTIAL
 THE INFORMATION CONTAINED IN THIS DRAWING IS THE SOLE PROPERTY OF SECURE CARE PRODUCTS, LLC. ANY REPRODUCTION IN PART OR AS A WHOLE WITHOUT THE WRITTEN PERMISSION OF SECURE CARE PRODUCTS, LLC IS PROHIBITED.

| | | | | |
|--|---------|------------|------------------|--|
| UNLESS OTHERWISE SPECIFIED: | | NAME | DATE | SECURE CARE PRODUCTS, LLC 39 CHENELL DR. CONCORD NH 03301 |
| DIMENSIONS ARE IN INCHES TOLERANCES: 2 PLACE DECIMAL ±.010 3 PLACE DECIMAL ±.005 4 PLACE DECIMAL ±.002 ANGLES = ±0.5° DO NOT SCALE DRAWING REMOVE ALL BURRS AND SHARP EDGES | | DRAWN | J.DIXON | |
| MATERIAL | | CHECKED | C.STEVENS | 10/8/14 |
| FINISH | | ENG APPR. | | |
| NEXT ASSY | USED ON | MFG APPR. | | |
| APPLICATION | | Q.A. | | |
| DO NOT SCALE DRAWING | | COMMENTS: | | |
| THIRD ANGLE PROJECTION | | | | TITLE: CUTBAND TRANSMITTER STANDARD |
| | | SIZE | DWG. NO. | REV |
| | | B | P20470900 | 000 |
| | | SCALE: 1:1 | WEIGHT: | SHEET 1 OF 3 |

8 7 6 5 4 3 2 1

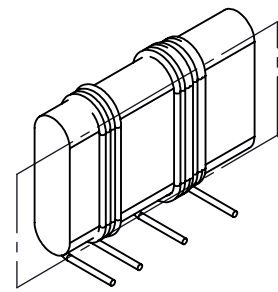

CUT AND PLACE A PIECE OF KAPTON TAPE IN THE AREA SHOWN. TAPE CAN FOLD UP EACH FLAT SIDE OF THE FERRITE, BUT SHOULD NOT COVER THE ROUNDED SIDES

APPLY LIGHT CURING RTV TO SECURE CUTBAND CONTACTS TO THE CRADLE

APPLY LIGHT CURING RTV TO SECURE ANTENNA TO CRADLE AND BOARD

APPLY LIGHT CURING RTV TO SECURE CRADLE TO THE BOARD

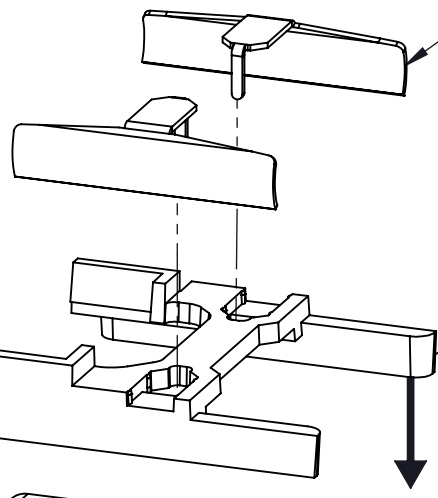
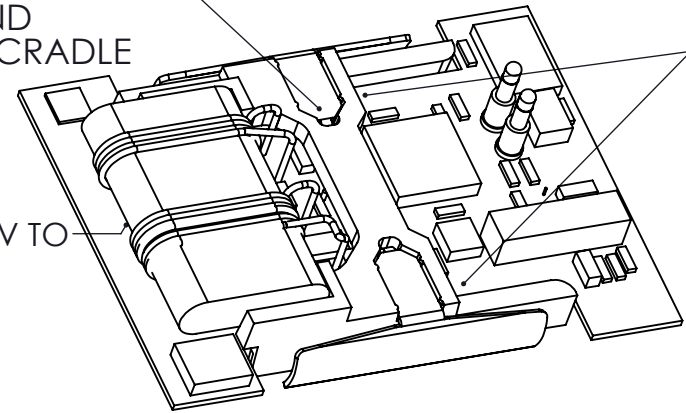

CUTBAND CONTACTS SHOULD FIT INTO THE CRADLE DESIGNATED FOR THIS DESIGN

PLACE CRADLE ON BOARD AND POSITION ANTENNA BETWEEN THE GUIDES

SOLDER THE 4 LEADS ON THE FERRITE TO THE PCB BOARD

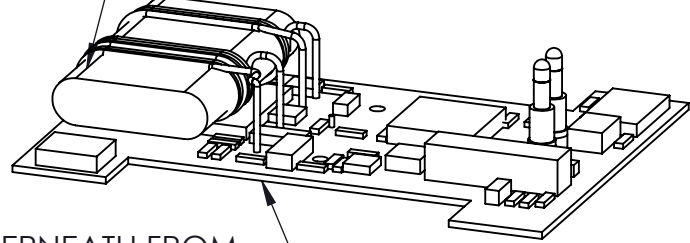

TRIM LEADS UNDERNEATH FROM THE FERRITE ANTENNA

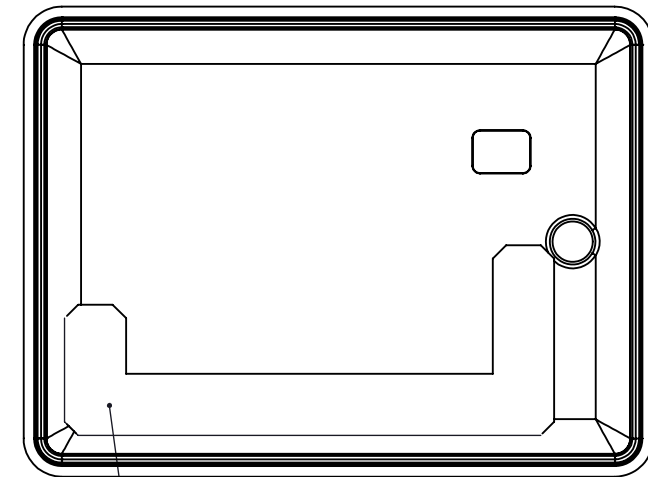

POSITION FOIL ANTENNA INTO COVER AS SHOWN. USE ANTENNA ALIGNMENT FIXTURE.

PROPRIETARY AND CONFIDENTIAL
THE INFORMATION CONTAINED IN THIS DRAWING IS THE SOLE PROPERTY OF SECURE CARE PRODUCTS, LLC. ANY REPRODUCTION IN PART OR AS A WHOLE WITHOUT THE WRITTEN PERMISSION OF SECURE CARE PRODUCTS, LLC IS PROHIBITED.

UNLESS OTHERWISE SPECIFIED:

DIMENSIONS ARE IN INCHES
TOLERANCES:
2 PLACE DECIMAL ±.010
3 PLACE DECIMAL ±.005
4 PLACE DECIMAL ±.002
ANGLES = ±0.5°
DO NOT SCALE DRAWING
REMOVE ALL BURRS AND SHARP EDGES

MATERIAL

FINISH

DO NOT SCALE DRAWING

| | NAME | DATE |
|-----------|------------|---------|
| DRAWN | B. PERCOCO | 1/11/12 |
| CHECKED | | |
| ENG APPR. | | |
| MFG APPR. | | |
| Q.A. | | |
| COMMENTS: | | |

THIRD ANGLE PROJECTION

SECURE CARE PRODUCTS, LLC
39 CHENELL DR. CONCORD NH 03301

TITLE: **CUTBAND TRANSMITTER STANDARD**

SIZE **B** DWG. NO. **P20470900** REV **000**

SCALE: 1:1 WEIGHT: SHEET 2 OF 3

| APPLICATION | USED ON |
|-------------|---------|
| NEXT ASSY | |

8 7 6 5 4 3 2 1

D

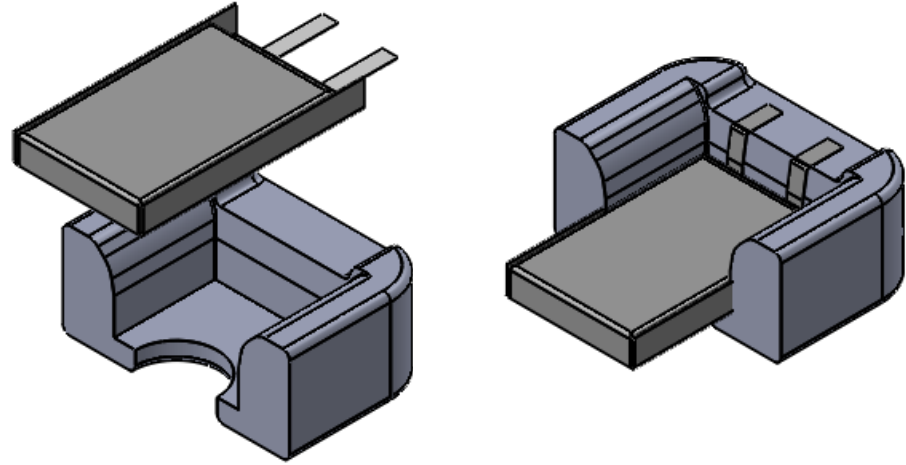

PRESS BATTERY FIRMLY INTO BATTERY FOLDING FIXTURE

C

B

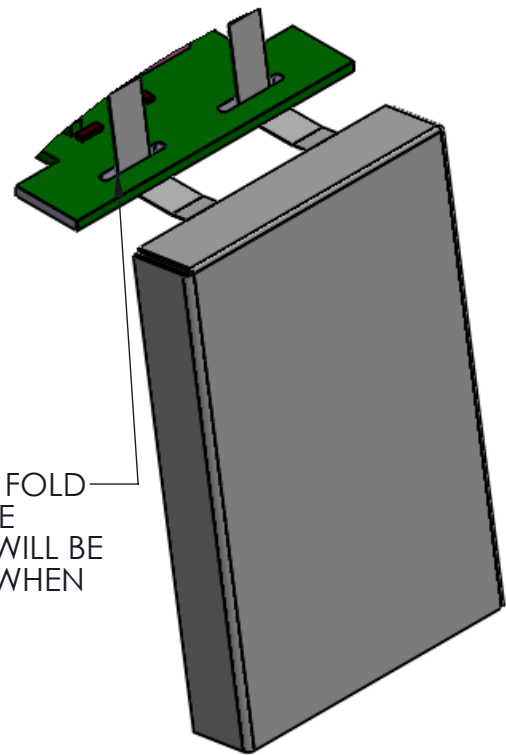

ONCE THE BATTERY IS IN PLACE, FOLD THE TABS OVER THE EDGE OF THE FIXTURE AS SHOWN. THIS FOLD WILL BE WHERE THE PCB BOTTOMS OUT WHEN SOLDERING TO THE BATTERY.

A

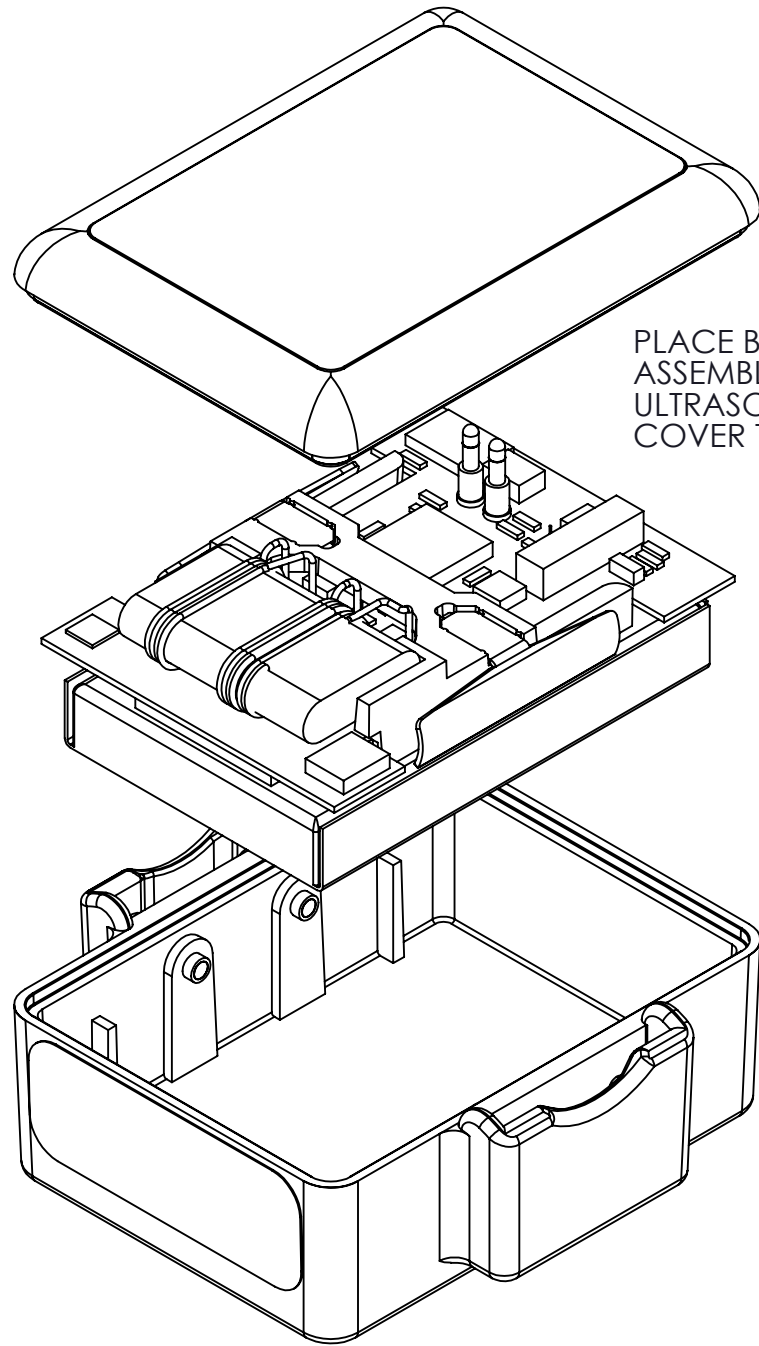

PLACE BOARD AND BATTERY ASSEMBLY INTO BASE, AND ULTRASONICALLY WELD THE COVER TO THE BASE

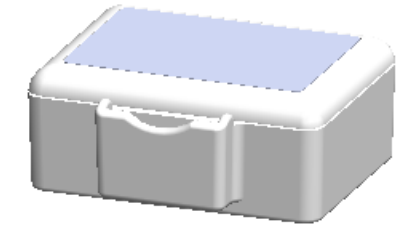

ONCE THE PART IS WELDED TOGETHER, PLACE LABEL ON TOP WITH HALF OF THE RELEASE LINER STILL ATTACHED SO THE TRANSMITTER CAN BE SWITCHED ON BEFORE SHIPPING

D

C

B

A

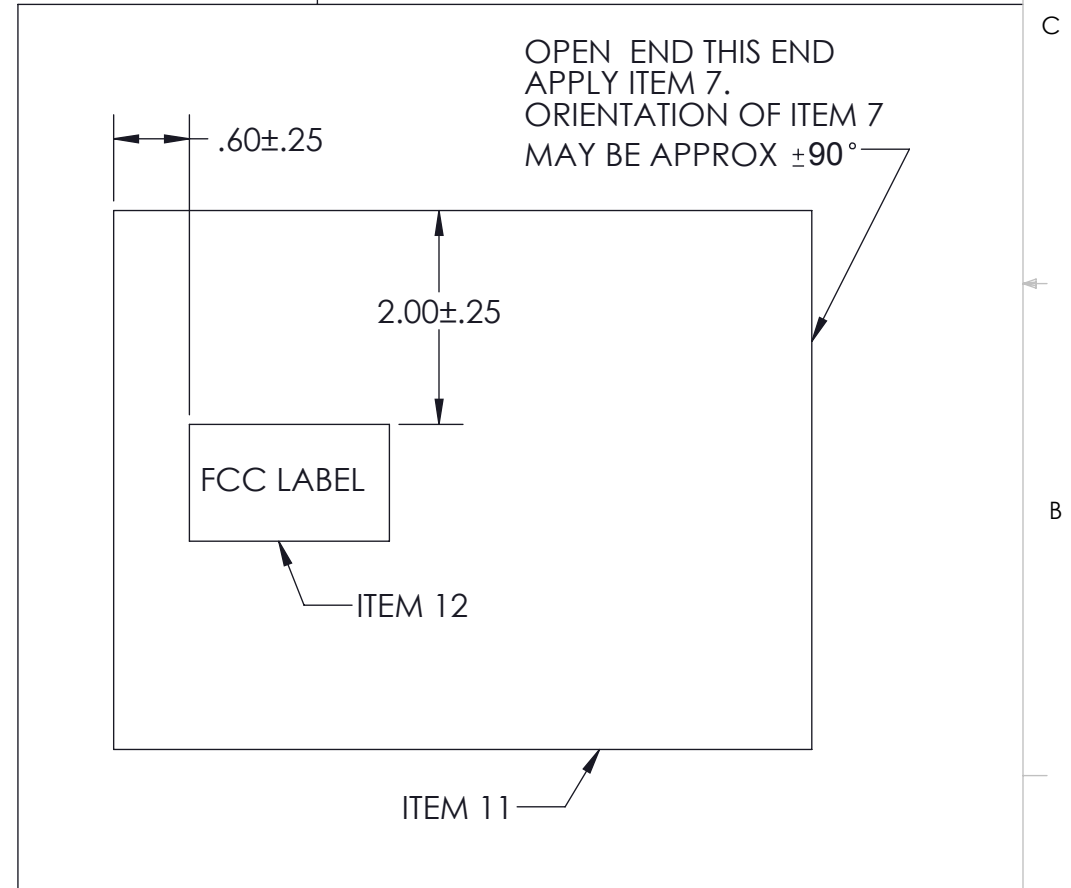

PROPRIETARY AND CONFIDENTIAL
THE INFORMATION CONTAINED IN THIS DRAWING IS THE SOLE PROPERTY OF SECURE CARE PRODUCTS, LLC. ANY REPRODUCTION IN PART OR AS A WHOLE WITHOUT THE WRITTEN PERMISSION OF SECURE CARE PRODUCTS, LLC IS PROHIBITED.

| | | | | | | | |
|-------------|---------|--|--------|------------------------|-----------|--|--------------|
| | | UNLESS OTHERWISE SPECIFIED: | | NAME | DATE | SECURE CARE PRODUCTS, LLC 39 CHENELL DR. CONCORD NH 03301 | |
| | | DIMENSIONS ARE IN INCHES TOLERANCES: 2 PLACE DECIMAL ±.010 3 PLACE DECIMAL ±.005 4 PLACE DECIMAL ±.002 ANGLES = ±0.5° DO NOT SCALE DRAWING REMOVE ALL BURRS AND SHARP EDGES | | DRAWN | J.DIXON | | 10/8/14 |
| | | | | CHECKED | C.STEVENS | 10/8/14 | |
| | | | | ENG APPR. | | | |
| | | | | MFG APPR. | | | |
| | | | | Q.A. | | | |
| | | | | COMMENTS: | | TITLE: CUTBAND TRANSMITTER STANDARD | |
| | | | | THIRD ANGLE PROJECTION | | | |
| NEXT ASSY | USED ON | MATERIAL | FINISH | SIZE | | DWG. NO. | REV |
| | | | | B | | P20470900 | 000 |
| APPLICATION | | DO NOT SCALE DRAWING | | SCALE: 1:1 | | WEIGHT: | SHEET 3 OF 3 |

8 7 6 5 4 3 2 1