

UNII-1+2A RF Test Report

regarding

USA: CFR Title 47, Part 15.407 (Emissions)

Canada: IC RSS-247v2/GENE (Emissions)

for

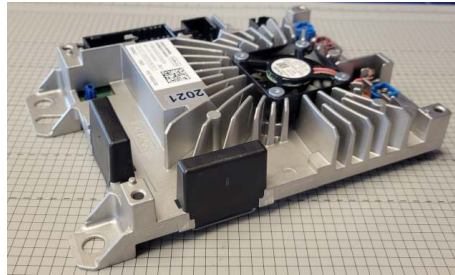

SG5PHX

Category: Vehicular Domain Controller

Judgments:

FCC 15.407, ISED RSS-247v2 Compliant

Testing Completed: March 5, 2023



Prepared for:

Ford Motor Company

Building 5 20300 Rotunda Dr., Dearborn Michigan 48124 United States

Phone: 313-805-5627, Fax: 313-845-3804

Contact: David Orris, dorris@ford.com

Data Rec./Rev. by:

Joseph Brunett
Dr. Joseph Brunett, EMC-002790-NE

Rpt. Auth. by:

Joseph Brunett
Dr. Joseph Brunett, EMC-002790-NE

Rpt. Prep./Rev. by:

John Nantz
John Nantz

Date of Issue:

March 5, 2023

Revision History

Rev. No.	Date	Details	Revised By
r0	March 5, 2023	Initial Release.	J. Brunett
r1	May 5, 2023	Updates per TCB comments.	J. Brunett
r2	May 31, 2023	Correct ISED EIRP limit.	J. Brunett

Contents

Revision History	2
Table of Contents	2
1 Test Report Scope and Limitations	5
1.1 Laboratory Authorization	5
1.2 Report Retention	5
1.3 Subcontracted Testing	5
1.4 Test Data	5
1.5 Limitation of Results	5
1.6 Copyright	5
1.7 Endorsements	5
1.8 Test Location	6
1.9 Traceability and Equipment Used	6
2 Test Specifications and Procedures	7
2.1 Test Specification and General Procedures	7
3 Configuration and Identification of the Equipment Under Test	8
3.1 Description and Declarations	8
3.1.1 EUT Configuration	9
3.1.2 Modes of Operation	9
3.1.3 Variants	9
3.1.4 Test Samples	9
3.1.5 Functional Exerciser	9
3.1.6 Modifications Made	10
3.1.7 Production Intent	10
3.1.8 Declared Exemptions and Additional Product Notes	10
4 Emissions	11
4.1 General Test Procedures	11
4.1.1 Radiated Test Setup and Procedures	11
4.1.2 Conducted Emissions Test Setup and Procedures	13
4.1.3 Power Supply Variation	13
4.2 Intentional Emissions	14
4.2.1 Duty and Transmission Cycle, Pulsed Operation	14
4.2.2 Fundamental Emission Bandwidth	16
4.2.3 Effective Isotropic Radiated Power	19
4.2.4 Emission Power Spectral Density	21
4.3 Unintentional Emissions	23
4.3.1 Restricted Band Transmit Chain Spurious Emissions	23
4.3.2 OOB Transmit Chain Spurious Emissions	29

5 Measurement Uncertainty and Accreditation Documents

32

List of Tables

1	Test Site List.	6
2	Equipment List.	6
3	EUT Declarations.	8
4	Pulsed Emission Characteristics (Duty Cycle).	14
5	Intentional Emission Bandwidth.	16
5	Intentional Emission Bandwidth.	17
6	Radiated Power Results.	19
6	Radiated Power Results.	20
7	Power Spectral Density Results.	21
8	Transmit Chain Spurious Emissions.	23
8	Transmit Chain Spurious Emissions.	24
8	Transmit Chain Spurious Emissions.	25
8	Transmit Chain Spurious Emissions.	26
8	Transmit Chain Spurious Emissions.	27
8	Transmit Chain Spurious Emissions.	28
9	Measurement Uncertainty.	32

List of Figures

1	Photos of EUT.	8
2	EUT Test Configuration Diagram.	9
3	Radiated Emissions Diagram of the EUT.	11
4	Radiated Emissions Test Setup Photograph(s).	12
5	Conducted RF Test Setup Photograph(s).	13
6	Example Pulsed Emission Characteristics (Duty Cycle).	15
7	Example Intentional Emission Bandwidth Plots.	18
8	Example Power Spectral Density Plots.	22
9	Worst Case Transmitter OOB Emissions Measured.	29
9	Worst Case Transmitter OOB Emissions Measured.	30
9	Worst Case Transmitter OOB Emissions Measured.	31
10	Accreditation Documents	32

1 Test Report Scope and Limitations

1.1 Laboratory Authorization

Test Facility description and attenuation characteristics are on file with the FCC Laboratory, Columbia, Maryland (FCC Reg. No: US5348 and US5356) and with ISED Canada, Ottawa, ON (File Ref. No: 3161A and 24249). Amber Helm Development L.C. holds accreditation under NVLAP Lab Code 200129-0.

1.2 Report Retention

For equipment verified to comply with the regulations herein, the manufacturer is obliged to retain this report with the product records for the life of the product, and no less than ten years. A copy of this Report will remain on file with this laboratory until March 2033.

1.3 Subcontracted Testing

This report does not contain data produced under subcontract.

1.4 Test Data

This test report contains data included within the laboratory's scope of accreditation. Any data in this report that is not covered under the laboratory's scope is clearly identified.

1.5 Limitation of Results

The test results contained in this report relate only to the item(s) tested. Any electrical or mechanical modification made to the test item subsequent to the test date shall invalidate the data presented in this report. Any electrical or mechanical modification made to the test item subsequent to this test date shall require reevaluation.

1.6 Copyright

This report shall not be reproduced, except in full, without the written approval of Amber Helm Development L.C.

1.7 Endorsements

This report shall not be used to claim product endorsement by any accrediting, regulatory, or governmental agency.

1.8 Test Location

The EUT was fully tested by **Amber Helm Development L.C.**, headquartered at 92723 Michigan Hwy-152, Sister Lakes, Michigan 49047 USA. Table 1 lists all sites employed herein. Specific test sites utilized are also listed in the test results sections of this report where needed.

Table 1: Test Site List.

Description	Location	Quality Num.
OATS (3 meter)	3615 E Grand River Rd., Williamston, Michigan 48895	OATSC

1.9 Traceability and Equipment Used

Pertinent test equipment used for measurements at this facility is listed in Table 2. The quality system employed at Amber Helm Development L.C. has been established to ensure all equipment has a clearly identifiable classification, calibration expiry date, and that all calibrations are traceable to the SI through NIST, other recognized national laboratories, accepted fundamental or natural physical constants, ratio type of calibration, or by comparison to consensus standards.

Table 2: Equipment List.

Description	Manufacturer/Model	SN	Quality Num.	Cal/Ver By / Date Due
EMI Receiver	R & S / ESW26	101313	RSESW2601	RS / October-2023
Spec. Analyzer 70GHz	Anritsu / MS2760A	1705006	ANMS2760A1	ANR / Sept-2023
Pk/Avg Pwr Mtr	BK Prec. / RFP3008	620C22101	BKPM300801	BK / Mar-2024
Power Meter	R & S / NRP50S	101087	RSNRP50	RS / Nov-2024

2 Test Specifications and Procedures

2.1 Test Specification and General Procedures

The goal of Ford Motor Company is to demonstrate that the Equipment Under Test (EUT) complies with the Rules and/or Directives below. Detailed in this report are the results of testing the Ford Motor Company SG5PHX for compliance to:

Country/Region	Rules or Directive	Referenced Section(s)
United States	Code of Federal Regulations	CFR Title 47, Part 15.407
Canada	ISED Canada	IC RSS-247v2/GENe

It has been determined that the equipment under test is subject to the rules and directives above at the date of this testing. In conjunction with these rules and directives, the following specifications and procedures are followed herein to demonstrate compliance (in whole or in part) with these regulations.

ANSI C63.4:2014	"Methods of Measurement of Radio-Noise Emissions from Low-Voltage Electrical and Electronic Equipment in the Range of 9 kHz to 40 GHz"
ANSI C63.10:2013	"American National Standard of Procedures for Compliance Testing of Unlicensed Wireless Devices"
KDB 789033 D02 v02r01	"GUIDELINES FOR COMPLIANCE TESTING OF UNLICENSED NATIONAL INFORMATION INFRASTRUCTURE (U-NII) DEVICES PART 15, SUBPART E "
KDB 905462 D07 v02 r01	"OVERVIEW OF REVISED RULES FOR U-NII DEVICES"
KDB 905462 D03 v01 r02	"U-NII CLIENT DEVICES WITHOUT RADAR DETECTION CAPABILITY"
TP0102RA	"AHD Internal Document TP0102 - Radiated Emissions Test Procedure"

3 Configuration and Identification of the Equipment Under Test

3.1 Description and Declarations

The equipment under test is a vehicle entertainment and information system containing Bluetooth, BLE, and 2x2 WiFi. The EUT is approximately 15 x 22 x 4 cm in dimension, and is depicted in Figure 1. It is powered by 13.5 VDC nominal vehicular power system. In use, this device is a vehicle entertainment module permanently installed into Ford motor vehicles. Table 3 outlines provider declared EUT specifications.

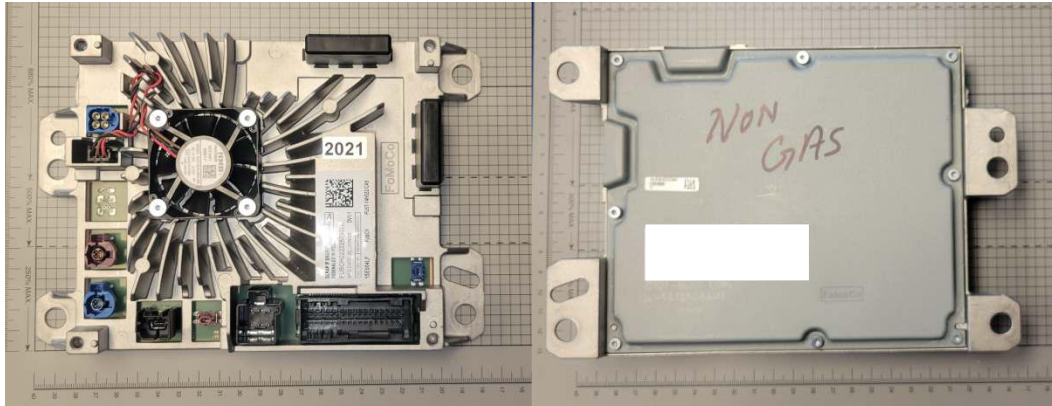

Figure 1: Photos of EUT.

Table 3: EUT Declarations.

General Declarations	
Equipment Type:	Vehicular Domain Controller
Country of Origin:	Not Declared
Nominal Supply:	13.5 VDC nominal
Oper. Temp Range:	-40°C to +75°C
Frequency Range:	5G LE-LAN(5150 – 5250, 5350 – 5590, 5650 – 5725, 5735 – 5835 MHz)
Antenna Dimension:	Integral
Antenna Type:	PCB Trace
Antenna Gain:	8.8 dBi max. (5150 – 5250, 5350 – 5590, 5650 – 5725, 5735 – 5835 MHz)
Number of Channels:	5G W52/UNII-1 20M(36,40,44,48), 40M(38,46), 80M(42) 5G W53/UNII-2A 20M(52,56,60,64), 40M(54,62), 80M(58)
Channel Spacing:	5G WIFI 20, 40, 80 MHz
Alignment Range:	Not Declared
Type of Modulation:	5G WIFI: A(20/40)SISO, N(20/40),AC(20/40/80),AX(20/40/80)SISO+MIMO
United States	
FCC ID Number:	KMH-SG5PHX
Classification:	NII
Canada	
IC Number:	1422A-SG5PHX
Classification:	Vehicle Entertainment/Network Device

3.1.1 EUT Configuration

The EUT is configured for testing as depicted in Figure 2.

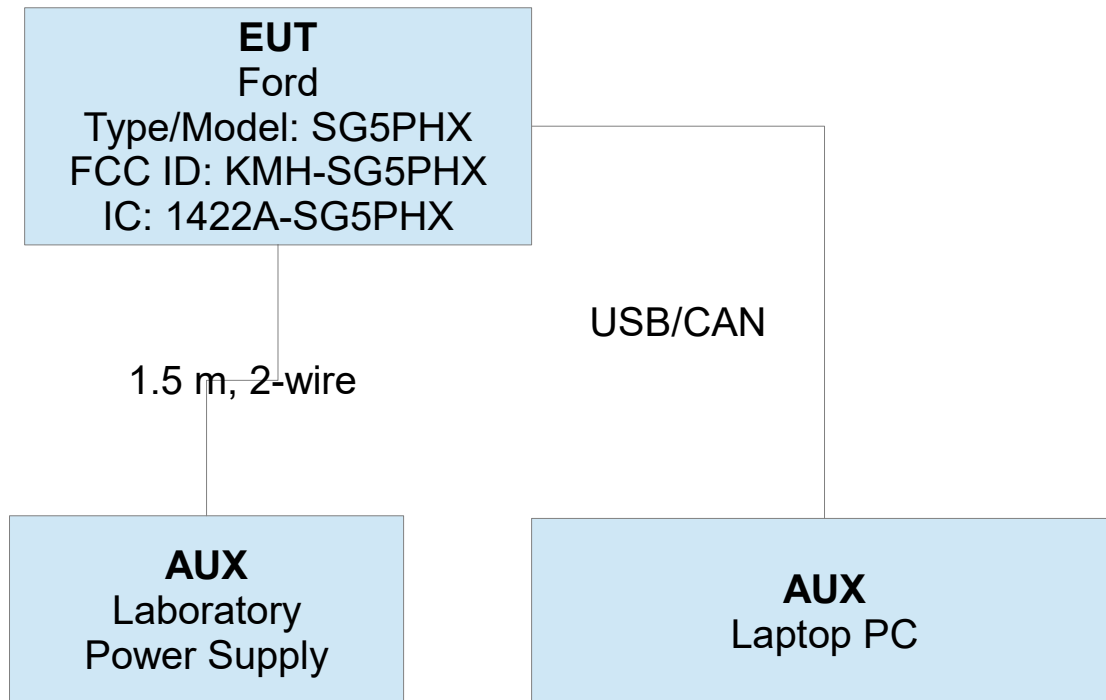

Figure 2: EUT Test Configuration Diagram.

3.1.2 Modes of Operation

The EUT employs two radio paths (PATH A and PATH B), over six modes (BT, BLE, 2G-BG-STA, 2G-N-STA, 5G-STA, 5G-AP). This report addresses only the following modes, and only in the UNII-1/2A bands. **MODE 5G-STA:** In this mode the EUT operates as CLIENT ONLY radio across the UNII-1(W52), UNII-2A(W53), UNII-2C(W56), and UNII-3(W58) bands between 5150 and 5835 MHz. This mode employs SISO PATH A, SISO PATH B, or MIMO PATH A + B simultaneously. **MODE 5G-AP:** AP (Access Point) mode where the WiFi radio operates as master access point in the UNII-1(W52) and UNII-3(W58) bands only. This mode employs SISO PATH A, SISO PATH B, or MIMO PATH A + B simultaneously.

3.1.3 Variants

There is only a single variant of the EUT, as tested.

3.1.4 Test Samples

Four samples of the EUT were provided in total, two normal (production ready) samples (SN: 2020, 2021) with integral antennas and two with the antennas replaced by coaxial cable connections (SN:2016, 1376). Each sample provided was capable of receiving radio instructions via CAN + USB interface to a personal computer. The manufacturer provided software tools and firmware need to place the EUT radio into test and normal operating modes.

3.1.5 Functional Exerciser

Normal functionality was confirmed by measurement of transmitted signals.

3.1.6 Modifications Made

There were no modifications made to the EUT by this laboratory. However, conducted RF emissions pretesting indicated that the EUT radio country designation across all UNII bands had to be fixed on the country code for Canada (CA) in order to meet the regulatory limitations for both USA and Canada. Manufacturer state the USA country code (US) settings will be set to match those of the CA country code, as tested.

3.1.7 Production Intent

The EUT appears to be a production ready sample.

3.1.8 Declared Exemptions and Additional Product Notes

The EUT employs AP mode of operation only the UNII-1/W52 and UNII-3/W58 bands. UNII-2A/W53, UNII-2C/W56 are employed only when in STA (client) mode. In the W53 and W56 bands the Radio operates as a slave/client without radar detection and is subject Channel Shutdown DFS reported in a separate DFS test report. The EUT is permanently installed in a transportation vehicle. As such, digital emissions are exempt from US and Canadian digital emissions regulations (per FCC 15.103(a) and IC correspondence on ICES-003). General spurious emissions (cabinet emissions with the EUT antenna ports terminated) are reported in the associated spurious emission test report for this product.

4 Emissions

4.1 General Test Procedures

4.1.1 Radiated Test Setup and Procedures

Radiated electromagnetic emissions from the EUT are first pre-scanned in our screen room. Spectrum and modulation characteristics of all emissions are recorded. Instrumentation, including spectrum analyzers and other test equipment as detailed in Section 1.8 are employed. After pre-scan, emission measurements are made on the test site of record. If the EUT connects to auxiliary equipment and is table or floor standing, the configurations prescribed in relevant test standards are followed. Alternatively, a layout closest to normal use (as declared by the provider) is employed if the resulting emissions appear to be worst-case in such a configuration. See Figure 3. All intentionally radiating elements that are not fixed-mounted in use are placed on the test table lying flat, on their side, and on their end (3-axes) and the resulting worst case emissions are recorded. If the EUT is fixed-mounted in use, measurements are made with the device oriented in the manner consistent with installation and then emissions are recorded. If the EUT exhibits spurious emissions due to internal receiver circuitry, such emissions are measured with an appropriate carrier signal applied.

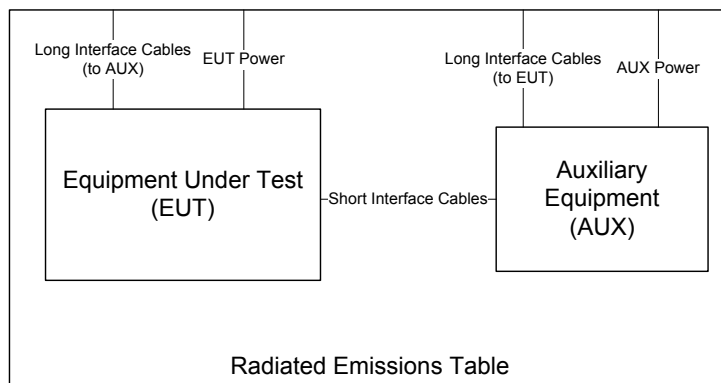

Figure 3: Radiated Emissions Diagram of the EUT.

For devices with intentional emissions below 30 MHz, a shielded loop antenna and/or E-field and H-Field broadband probes are used depending on the regulation. Shielded loops are placed at a 1 meter receive height at the desired measurement distance. For exposure in this band, 10cm diameter single-axis broadband probes meeting the requirements of ISED SPR-002 section 5.2 are employed. Measurements are repeated and summed over three axes, and the entire frequency range is measured with and without the EUT transmitting.

Emissions between 30 MHz and 1 GHz are measured using calibrated broadband antennas. For both horizontal and vertical polarizations, the test antenna is raised and lowered from 1 to 4 m in height until a maximum emission level is detected. The EUT is then rotated through 360° in azimuth until the highest emission is detected. The test antenna is then raised and lowered one last time from 1 to 4 m and the worst case value is recorded. Emissions above 1 GHz are characterized using standard gain or broadband ridge-horn antennas on our OATS with a 4×5 m rectangle of ECCOSORB absorber covering the OATS ground screen and a 1.5m table height. Care is taken to ensure that test receiver resolution and video bandwidths meet the regulatory requirements, and that the emission bandwidth of the EUT is not reduced. Photographs of the test setup employed are depicted in Figure 4.

Where regulations allow for direct measurement of field strength, power values (dBm) measured on the test receiver / analyzer are converted to $\text{dB}\mu\text{V}/\text{m}$ at the regulatory distance, using

$$E_{dist} = 107 + P_R + K_A - K_G + K_E - C_F$$

where P_R is the power recorded on spectrum analyzer, in dBm, K_A is the test antenna factor in dB/m, K_G is the combined pre-amplifier gain and cable loss in dB, K_E is duty correction factor (when applicable) in dB, and C_F is a distance conversion (employed only if limits are specified at alternate distance) in dB. This field strength value is then compared with the regulatory limit. If effective isotropic radiated power (EIRP) is computed, it is computed as

$$EIRP(\text{dBm}) = E_{3m}(\text{dB}\mu\text{V}/\text{m}) - 95.2.$$

When presenting data at each frequency, the highest measured emission under all possible EUT orientations (3-axes) is reported.

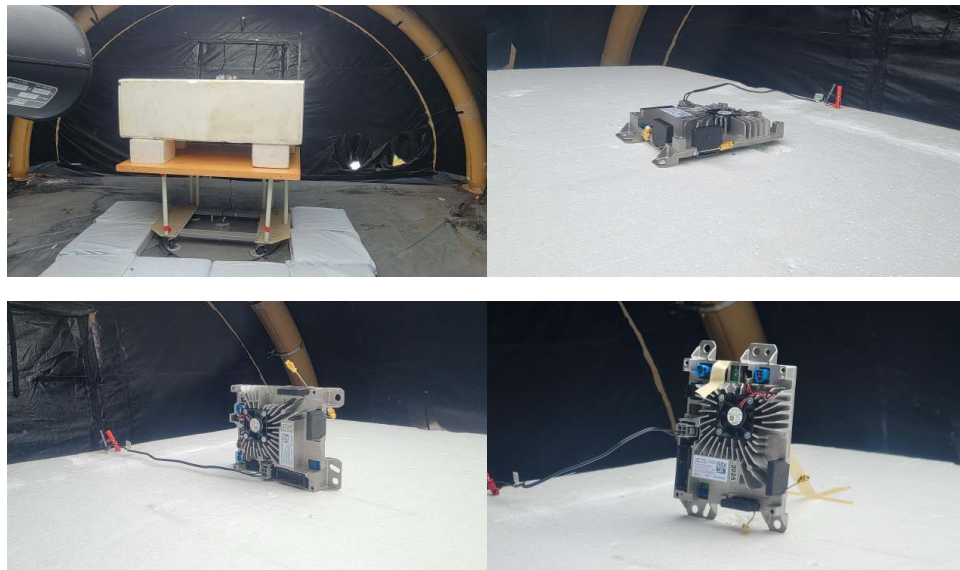

Figure 4: Radiated Emissions Test Setup Photograph(s).

4.1.2 Conducted Emissions Test Setup and Procedures

Transmit Antenna Port Conducted Emissions At least one sample EUT supplied for testing was provided with a 50Ω antenna port. Conducted transmit chain emissions measurements (where applicable) are made by connecting the EUT antenna port directly to the test receiver port. Photographs of the test setup employed are depicted in Figure 5.

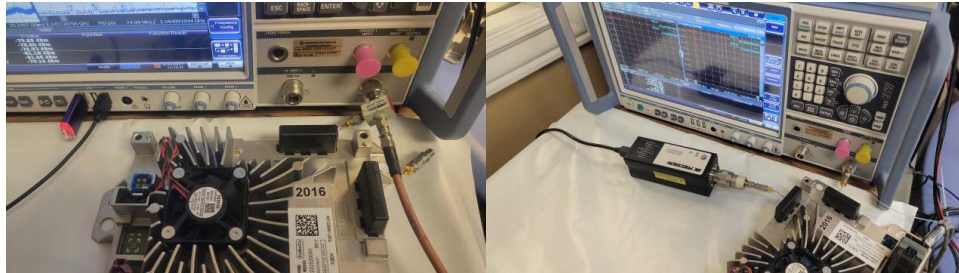

Figure 5: Conducted RF Test Setup Photograph(s).

4.1.3 Power Supply Variation

Tests at extreme supply voltages are made if required by the procedures specified in the test standard, and results of this testing are detailed in this report.

4.2 Intentional Emissions

4.2.1 Duty and Transmission Cycle, Pulsed Operation

The details and results of testing the EUT for pulsed operation are summarized in Table 4. Plots showing the measurements made to obtain these values are provided in Figure 6.

Table 4: Pulsed Emission Characteristics (Duty Cycle).

FCC 15.407 / RSS-247									
R0	Worst Case Mode	Temp	Test Channel	Path	Test Freq (MHz)	On-Time (ms)	Period (ms)	Meas. Duty Cycle (%)	Pwr Duty Correction (dB)
R1	802.11a(20), 6Mbps, SISO	20	CH36	A / B	5180.0	1.429	1.528	93.5	0.3
R2	802.11n(20), HT0, SISO	20	CH36	A / B	5180.0	1.337	1.436	93.1	0.3
R3	802.11n(20), HT0, MIMO	20	CH36	A / B	5180.0	0.080	0.096	83.8	0.8
R4	802.11n(40), HT0, SISO	20	CH38	A / B	5190.0	0.665	0.764	87.1	0.6
R5	802.11n(40), HT0, MIMO	20	CH38	A / B	5190.0	0.056	0.072	78.0	1.1
R6	802.11ac(40), VHT0, SISO	20	CH38	A / B	5190.0	0.669	0.767	87.2	0.6
R7	802.11ac(40), VHT0, MIMO	20	CH38	A / B	5190.0	0.064	0.080	80.2	1.0
R8	802.11ac(80), VHT0, SISO	20	CH42	A / B	5210.0	0.044	0.060	73.3	1.3
R9	802.11ac(80), VHT0, MIMO	20	CH42	A / B	5210.0	0.044	0.060	73.5	1.3
R10	802.11ax(20), HE0, SISO	20	CH36	A / B	5180.0	1.044	1.144	91.3	0.4
R11	802.11ax(20), HE0, MIMO	20	CH36	A / B	5180.0	0.082	0.098	83.9	0.8
R12	802.11ax(40), HE0, SISO	20	CH38	A / B	5190.0	0.551	0.650	84.8	0.7
R13	802.11ax(40), HE0, MIMO	20	CH38	A / B	5190.0	0.081	0.096	84.4	0.7
R14	802.11ax(80), HE0, SISO	20	CH42	A / B	5210.0	0.073	0.089	81.6	0.9
R15	802.11ax(80), HE0, MIMO	20	CH42	A / B	5210.0	0.076	0.092	82.3	0.8
#	C1	C2	C3	C4	C5	C6	C7	C8	C9
Row R1-R7		Column C8		Notes Measured following 789033 D02 General UNII Test Procedures New Rules v02r01 Section II B 2 b					

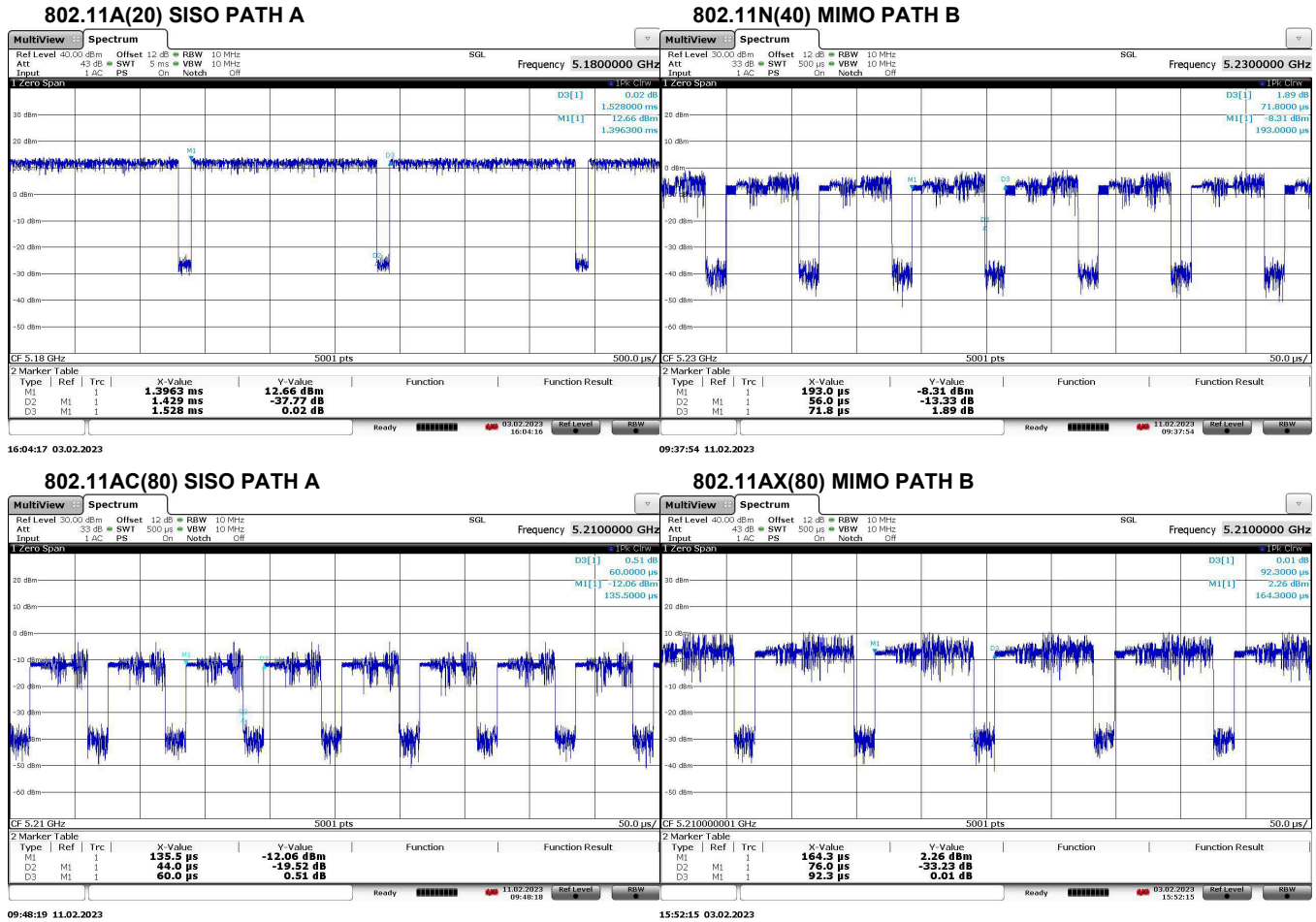

Figure 6: Example Pulsed Emission Characteristics (Duty Cycle).

4.2.2 Fundamental Emission Bandwidth

Emission bandwidth (EBW) of the EUT is measured with the device placed in the test mode(s) with the shortest available packet length and minimum packet spacing. Radiated emissions are recorded following the test procedures listed in Section 2.1. The Emission Bandwidth is measured for the lowest, middle, and highest channels available. The results of this testing are summarized in Table 5. Plots showing measurements employed obtain the emission bandwidths reported are provided in Figure 7.

Table 5(a): Intentional Emission Bandwidth.

Test Date: 2-Mar-23
Test Engineer: Joseph Brunett
Frequency Band: UNII-1 (5180 - 5240)
EUT: Ford SG5PHX
Meas. Distance: Conducted

R0	Worst Case Mode	Temp. C	Channel #	Freq. (MHz)	Volt (V)	Path A		Path B		Comments
						99% OBW (MHz)	26 dB EBW (MHz)	99% OBW (MHz)	26 dB EBW (MHz)	
R1	802.11a(20), 6Mbps, SISO	20	CH36	5180.0	13.5	16.87	21.22	16.91	21.31	
R2			CH40	5200.0	13.5	16.88	21.40	16.92	21.37	
R3			CH48	5240.0	13.5	16.88	21.40	16.89	21.25	
R5	802.11n(20), HT0, SISO	20	CH36	5180.0	13.5	17.95	21.67	17.93	21.41	
R6			CH40	5200.0	13.5	17.97	21.61	18.01	21.40	
R7			CH48	5240.0	13.5	17.96	21.61	17.96	21.41	
R8	802.11n(20), HT0, MIMO	20	CH36	5180.0	13.5	17.71	21.29	17.73	21.31	
R9			CH40	5200.0	13.5	17.73	21.29	17.73	21.34	
R10			CH48	5240.0	13.5	17.73	21.29	17.74	21.07	
R11	802.11n(40), HT0, SISO	20	CH38	5190.0	13.5	36.41	40.51	36.37	40.36	
R12			CH46	5230.0	13.5	36.36	40.31	36.38	40.16	
R14	802.11n(40), HT0, MIMO	20	CH38	5190.0	13.5	36.21	40.22	36.30	40.19	
R15			CH46	5230.0	13.5	36.08	40.05	36.20	40.07	
R17	802.11ac(80), VHT0, SISO	20	CH42	5210.0	13.5	76.13	82.02	76.11	81.10	
R19	802.11ac(80), VHT0, MIMO	20	CH42	5210.0	13.5	75.90	81.52	75.82	81.10	
R21	802.11ax(20), HE0, SISO	20	CH36	5180.0	13.5	19.09	21.55	19.08	21.37	
R22			CH40	5200.0	13.5	19.09	21.43	19.11	21.42	
R23			CH48	5240.0	13.5	19.09	21.43	19.05	21.43	
R24	802.11ax(20), HE0, MIMO	20	CH36	5180.0	13.5	19.03	21.37	19.03	21.16	
R25			CH40	5200.0	13.5	18.95	21.37	19.02	21.22	
R26			CH48	5240.0	13.5	18.95	21.37	19.03	21.31	
R27	802.11ax(40), HE0, SISO	20	CH38	5190.0	13.5	37.62	40.01	37.59	39.82	
R28			CH46	5230.0	13.5	37.56	40.26	37.65	39.86	
R30	802.11ax(40), HE0, MIMO	20	CH38	5190.0	13.5	37.44	39.77	37.63	39.86	
R31			CH46	5230.0	13.5	37.31	39.98	37.61	40.01	
R33	802.11ax(80), HE0, SISO	20	CH42	5210.0	13.5	77.03	81.32	77.12	81.22	
R35	802.11ax(80), HE0, MIMO	20	CH42	5210.0	13.5	76.91	81.22	76.94	81.09	
#	C1	C2	C3	C4	C5	C6	C7	C8	C9	C10

Row **Column** **Notes**
all C1 Pretesting utilized to confirm worst case operating modes.
all C6-C9 Measured conducted from the radio using conducted test sample.
all C6-C9 Measured following 789033 D02 General UNII Test Procedures New Rules v02r01 Section II C 1, D

Table 5(b): Intentional Emission Bandwidth.

Test Date: 2-Mar-23
 Test Engineer: Joseph Brunett

Frequency Band: UNII-2A (5260 - 5320)
 EUT: Ford SG5PHX
 Meas. Distance: Conducted

R0	Worst Case Mode	Temp. C	Channel #	Freq. (MHz)	Volt (V)	Path A		Path B		Comments
						99% OBW (MHz)	26 dB EBW (MHz)	99% OBW (MHz)	26 dB EBW (MHz)	
R1	802.11a(20), 6Mbps, SISO	20	CH52	5260.0	13.5	16.89	21.22	16.89	21.31	
R2			CH56	5280.0	13.5	16.88	21.40	16.89	21.37	
R3			CH64	5320.0	13.5	16.90	21.19	16.89	21.25	
R4	802.11n(20), HT0, SISO	20	CH52	5260.0	13.5	17.93	21.67	18.00	21.41	
R5			CH56	5280.0	13.5	17.96	21.61	17.98	21.38	
R6			CH64	5320.0	13.5	17.92	21.49	17.96	21.41	
R7	802.11n(20), HT0, MIMO	20	CH52	5260.0	13.5	17.74	21.29	17.69	21.31	
R8			CH56	5280.0	13.5	17.74	21.29	17.70	21.34	
R9			CH64	5320.0	13.5	17.75	21.32	17.74	21.07	
R10	802.11n(40), HT0, SISO	20	CH54	5270.0	13.5	36.21	40.51	36.37	40.36	
R11			CH62	5310.0	13.5	36.33	40.31	36.38	40.16	
R12	802.11n(40), HT0, MIMO	20	CH54	5270.0	13.5	36.15	40.22	36.30	40.19	
R13			CH62	5310.0	13.5	36.12	40.24	36.12	40.10	
R14	802.11ac(80), VHT0, SISO	20	CH58	5290.0	13.5	76.00	81.62	76.11	81.21	
R15	802.11ac(80), VHT0, MIMO	20	CH58	5290.0	13.5	75.95	81.52	75.90	81.20	
R16	802.11ax(20), HE0, SISO	20	CH52	5260.0	13.5	19.10	21.50	19.04	21.37	
R17			CH56	5280.0	13.5	19.09	21.30	19.03	21.42	
R18			CH64	5320.0	13.5	19.10	21.31	19.05	21.43	
R19	802.11ax(20), HE0, MIMO	20	CH52	5260.0	13.5	18.93	21.37	19.03	21.16	
R20			CH56	5280.0	13.5	19.00	21.37	19.02	21.22	
R21			CH64	5320.0	13.5	18.82	21.26	19.03	21.31	
R22	802.11ax(40), HE0, SISO	20	CH54	5270.0	13.5	37.55	40.01	37.59	39.82	
R23			CH62	5310.0	13.5	37.56	40.00	37.64	39.91	
R24	802.11ax(40), HE0, MIMO	20	CH54	5270.0	13.5	37.44	39.77	37.63	39.86	
R25			CH62	5310.0	13.5	37.42	39.70	37.50	39.86	
R26	802.11ax(80), HE0, SISO		CH58	5290.0	13.5	77.04	81.72	77.03	81.19	
R27	802.11ax(80), HE0, MIMO		CH58	5290.0	13.5	76.88	81.02	76.79	81.20	
#	C1	C2	C3	C4	C5	C6	C7	C8	C9	C10

Row
 all C1 Pretesting utilized to confirm worst case operating modes.
 all C6-C9 Measured conducted from the radio using conducted test sample.
 all C6-C9 Measured following 789033 D02 General UNII Test Procedures New Rules v02r01 Section II C 1, D

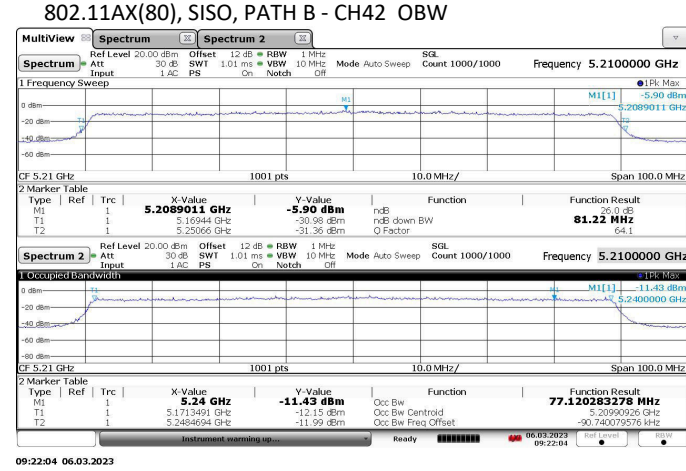
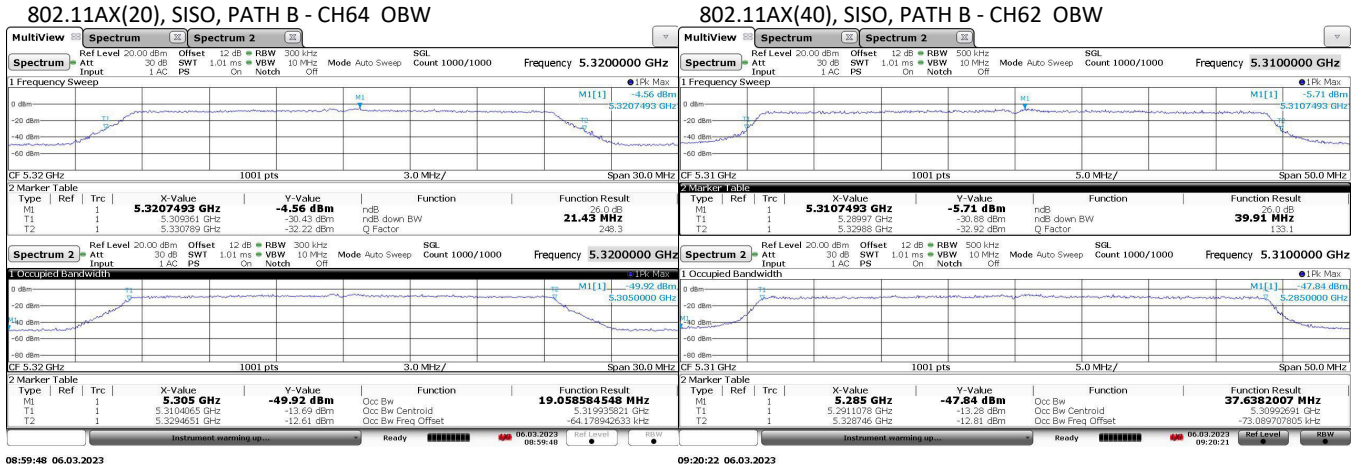

Figure 7: Example Intentional Emission Bandwidth Plots.

4.2.3 Effective Isotropic Radiated Power

The EUT’s radiated power is computed from antenna port conducted power measurements and the gain of the EUT antenna(s). Where the EUT is not sold with an antenna connector, a modified product has been provided including such. The results of this testing are summarized in Table 6.

Table 6(a): Radiated Power Results.

Test Date: 2/26/2023, 4/28/2023
Test Engineer: Joseph Brunett
Frequency Band: UNII-1 (5180 - 5240)
EUT: Ford SG5PHX
Meas. Distance: Conducted

R0	Worst Case Mode	Temp. C	Channel #	Freq. (MHz)	Volt (V)	Meas. Po (Avg)		Pwr Duty Cycle (dB)	Po (avg) max(SISO)/sum(MIMO)		Antenna Gain (dBi)	EIRP (Avg)		Pass (dB)
						Path A (dBm)	Path B (dBm)		Calc. (dBm)	FCC Limit (dBm)		Meas. (dBm)	ISED Limit (dBm)	
R1	802.11a(20), 6Mbps, SISO	20	CH36	5180.0	13.5	-0.3	-0.5	0.3	0.0	21.2	8.8	8.8	14.0	5.3
R2			CH40	5200.0	13.5	-0.5	-0.6		-0.2	21.2		8.6	14.0	5.5
R3			CH48	5240.0	13.5	-0.4	-0.6		-0.1	21.2		8.7	14.0	5.3
R4	802.11n(20), HT0, SISO	20	CH36	5180.0	13.5	-0.4	-0.6	0.3	-0.1	21.2	8.8	8.7	14.3	5.6
R5			CH40	5200.0	13.5	-0.4	-0.7		-0.1	21.2		8.7	14.3	5.6
R6			CH48	5240.0	13.5	-0.4	-0.7		-0.1	21.2		8.7	14.3	5.6
R7	802.11n(20), HT0, MIMO	20	CH36	5180.0	13.5	-1.0	-0.9	0.8	2.8	21.2	8.8	11.6	14.2	2.6
R8			CH40	5200.0	13.5	-1.1	-0.9		2.8	21.2		11.6	14.2	2.7
R9			CH48	5240.0	13.5	-1.2	-0.9		2.7	21.2		11.5	14.2	2.7
R10	802.11n(40), HT0, SISO	20	CH38	5190.0	13.5	0.1	-0.4	0.4	0.5	21.2	8.8	9.3	14.8	5.5
R11			CH46	5230.0	13.5	-0.1	-0.6		0.3	21.2		9.1	14.8	5.7
R12	802.11n(40), HT0, MIMO	20	CH38	5190.0	13.5	-1.4	-1.4	1.1	2.7	21.2	8.8	11.5	14.8	3.3
R13			CH46	5230.0	13.5	-1.5	-1.4		2.6	21.2		11.4	14.8	3.4
R14	802.11ac(80), VHT0, SISO	20	CH42	5210.0	13.5	-3.1	-4.1	1.3	-1.8	21.2	8.8	7.0	14.8	7.8
R15	802.11ac(80), VHT0, MIMO	20	CH42	5210.0	13.5	-3.9	-4.2	1.3	0.3	21.2	8.8	6.2	14.8	8.6
R16	802.11ax(20), HE0, SISO	20	CH36	5180.0	13.5	-1.1	-1.4	0.4	-0.7	21.2	8.8	8.1	14.6	6.5
R17			CH40	5200.0	13.5	-1.6	-1.7		-1.2	21.2		7.6	14.6	7.0
R18			CH48	5240.0	13.5	-1.6	-1.7		-1.2	21.2		7.6	14.6	7.0
R19	802.11ax(20), HE0, MIMO	20	CH36	5180.0	13.5	-1.8	-2.3	0.8	1.7	21.2	8.8	10.5	14.6	4.0
R20			CH40	5200.0	13.5	-2.0	-2.0		1.8	21.2		10.6	14.6	4.0
R21			CH48	5240.0	13.5	-2.0	-2.0		1.8	21.2		10.6	14.6	4.0
R22	802.11ax(40), HE0, SISO	20	CH38	5190.0	13.5	-2.0	-3.0	0.7	-1.3	21.2	8.8	7.5	14.8	7.3
R23			CH46	5230.0	13.5	-2.0	-2.8		-1.3	21.2		7.5	14.8	7.3
R24	802.11ax(40), HE0, MIMO	20	CH38	5190.0	13.5	-1.6	-1.9	0.7	2.0	21.2	8.8	10.8	14.8	4.0
R25			CH46	5230.0	13.5	-1.4	-2.3		1.9	21.2		10.7	14.8	4.1
R26	802.11ax(80), HE0, SISO	20	CH42	5210.0	13.5	-2.0	-2.3	0.9	-1.1	21.2	8.8	7.7	14.8	7.1
R27	802.11ax(80), HE0, MIMO	20	CH42	5210.0	13.5	-2.3	-2.0	0.8	1.7	21.2	8.8	7.6	14.8	7.2
#	C1	C2	C3	C4	C5	C6	C7	C8	C9	C10	C11	C12	C13	C14

Row **Column** **Notes**

all C1 Pretesting utilized to confirm worst case operating modes. Worst case modes are fully tested and reported herein.

all C6, C7 Measured conducted from the radio using conducted test sample.

all C6, C7 Measured following 789033 D02 General UNII Test Procedures New Rules v02r01 Section II E 3 a) - Method PM

all C9 For SISO, max of Path A / B. Form MIMO Linear Sum of Path A and Path B.

all C10 Client Device limit 24 dBm - (8.8 dBi antenna - 6 dBi allowance) = 21.2 dBm

all C11 SISO/MIMO antenna gain max = 8.8 dBi. MIMO completely uncorrelated.

all C13 ISED EIRP Limit in motor vehicles. Limit = Min (30 mW (14.8 dBm) , 1.76 + 10Log(99% BW MHz).

Table 6(b): Radiated Power Results.

Test Date: 2/26/2023, 4/28/2023
Test Engineer: Joseph Brunett
Frequency Band: UNII-2A (5260 - 5320)
EUT: Ford SG5PHX
Meas. Distance: Conducted

R0	Worst Case Mode	Temp. C	Channel #	Freq. (MHz)	Volt (V)	Meas. Po (Avg)		Pwr Duty Cycle (dB)	Po (avg) max(SISO)/sum(MIMO)		Antenna Gain (dBi)	EIRP (Avg)		Pass (dB)
						Path A (dBm)	Path B (dBm)		Calc. (dBm)	FCC Limit (dBm)		Meas. (dBm)	ISED Limit (dBm)	
R1	802.11a(20), 6Mbps, SISO	20	CH52	5260.0	13.5	-0.4	-0.5	0.3	-0.1	21.2	8.8	8.7	14.0	5.3
R2			CH56	5280.0	13.5	-0.5	-0.5		-0.2	21.2		8.6	14.0	5.4
R3			CH64	5320.0	13.5	-0.6	-0.6		-0.3	21.2		8.5	14.0	5.5
R4	802.11n(20), HT0, SISO	20	CH52	5260.0	13.5	-0.5	-0.6	0.3	-0.2	21.2	8.8	8.6	14.3	5.7
R5			CH56	5280.0	13.5	-0.6	-0.7		-0.3	21.2		8.5	14.3	5.8
R6			CH64	5320.0	13.5	-1.0	-0.8		-0.5	21.2		8.3	14.3	6.0
R7	802.11n(20), HT0, MIMO	20	CH52	5260.0	13.5	-1.1	-0.9	0.8	2.8	21.2	8.8	11.6	14.2	2.7
R8			CH56	5280.0	13.5	-1.2	-0.9		2.7	21.2		11.5	14.2	2.7
R9			CH64	5320.0	13.5	-1.5	-1.0		2.5	21.2		11.3	14.3	2.9
R10	802.11n(40), HT0, SISO	20	CH54	5270.0	13.5	0.0	-0.4	0.4	0.4	21.2	8.8	9.2	14.8	5.6
R11			CH62	5310.0	13.5	-0.2	-0.7		0.2	21.2		9.0	14.8	5.8
R12	802.11n(40), HT0, MIMO	20	CH54	5270.0	13.5	-1.9	-1.4	1.1	2.4	21.2	8.8	11.2	14.8	3.6
R13			CH62	5310.0	13.5	-2.0	-1.4		2.4	21.2		11.2	14.8	3.6
R14	802.11ac(80), VHT0, SISO	20	CH58	5290.0	13.5	-2.5	-2.9	1.3	-1.2	21.2	8.8	7.6	14.8	7.2
R15	802.11ac(80), VHT0, MIMO	20	CH58	5290.0	13.5	-3.5	-3.8	1.3	-2.2	21.2	8.8	6.6	14.8	8.2
R16	802.11ax(20), HE0, SISO	20	CH52	5260.0	13.5	-1.4	-1.1	0.4	-0.7	21.2	8.8	8.1	14.6	6.5
R17			CH56	5280.0	13.5	-1.4	-1.7		-1.0	21.2		7.8	14.6	6.8
R18			CH64	5320.0	13.5	-1.5	-2.0		-1.1	21.2		7.7	14.6	6.9
R19	802.11ax(20), HE0, MIMO	20	CH52	5260.0	13.5	-1.7	-2.3	0.8	1.8	21.2	8.8	10.6	14.6	4.0
R20			CH56	5280.0	13.5	-1.8	-1.9		1.9	21.2		10.7	14.6	3.8
R21			CH64	5320.0	13.5	-1.6	-1.8		2.1	21.2		10.9	14.6	3.7
R22	802.11ax(40), HE0, SISO	20	CH54	5270.0	13.5	-2.0	-3.0	0.7	-1.3	21.2	8.8	7.5	14.8	7.3
R23			CH62	5310.0	13.5	-1.7	-2.0		-1.0	21.2		7.8	14.8	7.0
R24	802.11ax(40), HE0, MIMO	20	CH54	5270.0	13.5	-1.1	-1.9	0.7	2.3	21.2	8.8	11.1	14.8	3.7
R25			CH62	5310.0	13.5	-1.0	-2.1		2.2	21.2		11.0	14.8	3.8
R26	802.11ax(80), HE0, SISO		CH58	5290.0	13.5	-1.6	-1.7	0.9	-0.7	21.2	8.8	8.1	14.8	6.7
R27	802.11ax(80), HE0, MIMO		CH58	5290.0	13.5	-2.4	-2.2	0.8	-1.4	21.2	8.8	7.4	14.8	7.4
#	C1	C2	C3	C4	C5	C6	C7	C8	C9	C10	C11	C12	C13	C14

Row **Column** **Notes**
 all C1 Pretesting utilized to confirm worst case operating modes. Worst case modes are fully tested and reported herein.
 all C6, C7 Measured conducted from the radio using conducted test sample.
 all C6, C7 Measured following 789033 D02 General UNII Test Procedures New Rules v02r01 Section II E 3 a) - Method PM
 all C9 For SISO, max of Path A / B. Form MIMO Linear Sum of Path A and Path B.
 all C10 Client Device limit 24 dBm - (8.8 dBi antenna - 6 dBi allowance) = 21.2 dBm
 all C11 SISO/MIMO antenna gain max = 8.8 dBi. MIMO completely uncorrelated.
 all C13 ISED EIRP Limit in motor vehicles. Limit = Min (30 mW (14.8 dBm) , 1.76 + 10Log(99% BW MHz).

4.2.4 Emission Power Spectral Density

For this test, the EUT was attached directly to the test receiver. Following FCC measurement procedures, the emission spectrum is first scanned for maximum spectral peaks, the span and receiver bandwidth are then reduced until the power spectral density is measured in the prescribed receiver bandwidth. The results of this testing are summarized in Table 7. Plots showing how these measurements were made are depicted in Figure 8.

Table 7: Power Spectral Density Results.

Test Date: 2/12/2023, 3/6/2023
Test Engineer: Joseph Brunett
Frequency Band: UNII-1/2A (5180 - 5320)
EUT: Ford SG5PHX
Meas. Distance: Conducted

R0	Worst Case Mode	Temp. C	Channel #	Freq. (MHz)	Supply Voltage (V)	PSD (rms)		Pwr Duty Cycle (dB)	PSD (rms) max(SISO),sum(MIMO)			Antenna Gain (dBi)	Pass (dB)
						Path A (dBm)	Path B (dBm)		Calc. (dBm)	FCC Client Limit (dBm)	ISED Limit (dBm)		
R1	802.11a(20), 6Mbps, SISO	20	CH36	5180.0	13.5	-15.5	-14.7	0.3	-14.4	8.2	10.0	8.8	22.6
R2			CH48	5240.0	13.5	-14.5	-13.8		-13.5	8.2	10.0		21.7
R3			CH64	5320.0	13.5	-14.1	-14.0		-13.7	8.2	10.0		21.9
R5	802.11n(20), HT0, SISO	20	CH36	5180.0	13.5	-15.2	-14.5	0.3	-14.2	8.2	10.0	8.8	22.4
R6			CH48	5240.0	13.5	-14.3	-14.1		-13.8	8.2	10.0		22.0
R7			CH64	5320.0	13.5	-14.2	-14.0		-13.7	8.2	10.0		21.9
R8	802.11n(20), HT0, MIMO	20	CH36	5180.0	13.5	-12.6	-12.3	0.8	-8.7	8.2	10.0	8.8	16.9
R9			CH48	5240.0	13.5	-12.4	-11.8		-8.3	8.2	10.0		16.5
R10			CH64	5320.0	13.5	-12.7	-12.9		-9.0	8.2	10.0		17.2
R11	802.11n(40), HT0, SISO	20	CH38	5190.0	13.5	-17.2	-16.8	0.4	-16.4	8.2	10.0	8.8	24.6
R12			CH46	5230.0	13.5	-17.0	-16.9		-16.5	8.2	10.0		24.7
R13			CH62	5310.0	13.5	-16.9	-17.0		-16.5	8.2	10.0		24.7
R14	802.11n(40), HT0, MIMO	20	CH38	5190.0	13.5	-16.9	-17.5	1.1	-13.1	8.2	10.0	8.8	21.3
R15			CH46	5230.0	13.5	-17.1	-17.6		-13.3	8.2	10.0		21.5
R16			CH62	5310.0	13.5	-17.3	-17.8		-13.5	8.2	10.0		21.7
R17	802.11ac(80), VHT0, SISO	20	CH42	5210.0	13.5	-22.9	-22.1	1.3	-20.8	8.2	10.0	8.8	29.0
R18			CH58	5290.0	13.5	-21.9	-22.0		-20.6	8.2	10.0		28.8
R19	802.11ac(80), VHT0, MIMO	20	CH42	5210.0	13.5	-21.3	-21.9	1.3	-17.2	8.2	10.0	8.8	25.4
R20			CH58	5290.0	13.5	-22.0	-22.3		-17.8	8.2	10.0		26.0
R21	802.11ax(20), HE0, SISO	20	CH36	5180.0	13.5	-15.5	-14.6	0.4	-14.2	8.2	10.0	8.8	22.4
R22			CH48	5240.0	13.5	-14.5	-14.9		-14.1	8.2	10.0		22.3
R23			CH64	5320.0	13.5	-14.4	-15.0		-14.0	8.2	10.0		22.2
R24	802.11ax(20), HE0, MIMO	20	CH36	5180.0	13.5	-15.0	-14.8	0.8	-11.1	8.2	10.0	8.8	19.3
R25			CH40	5200.0	13.5	-14.9	-14.7		-11.0	8.2	10.0		19.2
R26			CH48	5240.0	13.5	-14.7	-14.5		-10.8	8.2	10.0		19.0
R27	802.11ax(40), HE0, SISO	20	CH38	5190.0	13.5	-17.3	-17.1	0.7	-16.4	8.2	10.0	8.8	24.6
R28			CH46	5230.0	13.5	-16.9	-17.4		-16.2	8.2	10.0		24.4
R29			CH62	5310.0	13.5	-16.8	-17.3		-16.1	8.2	10.0		24.3
R30	802.11ax(40), HE0, MIMO	20	CH38	5190.0	13.5	-16.2	-15.4	0.7	-12.0	8.2	10.0	8.8	20.2
R31			CH46	5230.0	13.5	-16.1	-15.3		-11.9	8.2	10.0		20.1
R32			CH62	5310.0	13.5	-16.2	-15.6		-12.1	8.2	10.0		20.3
R33	802.11ax(80), HE0, SISO	20	CH42	5210.0	13.5	-21.4	-21.1	0.9	-20.2	8.2	10.0	8.8	28.4
R34			CH58	5290.0	13.5	-20.9	-21.0		-20.0	8.2	10.0		28.2
R35	802.11ax(80), HE0, MIMO	20	CH42	5210.0	13.5	-19.9	-18.5	0.8	-15.3	8.2	10.0	8.8	23.5
R36			CH58	5290.0	13.5	-20.0	-19.0		-15.6	8.2	10.0		23.8
#	C1	C2	C3	C4	C5	C6	C7	C8	C9	C10	C11	C12	C13

Row	Column	Notes
all	C1	Pretesting utilized to confirm worst case operating modes.
all	C6, C7	Measured conducted from the radio using conducted test sample.
all	C6, C7	Measured following 789033 D02 General UNII Test Procedures New Rules v02r01 Section II F Method SA-2 + Duty
all	C9	For SISO, max of Path A / B. For MIMO, Linear Sum of Path A and Path B.
all	C10	FCC PSD Client Limit 11 dBm/MHz + reduction, e.g. SISO 11dBm - (8.8 dBi antenna - 6 dBi allowance) = 8.2 dBm/MHz, MIMO 5.2 dBm/Δ

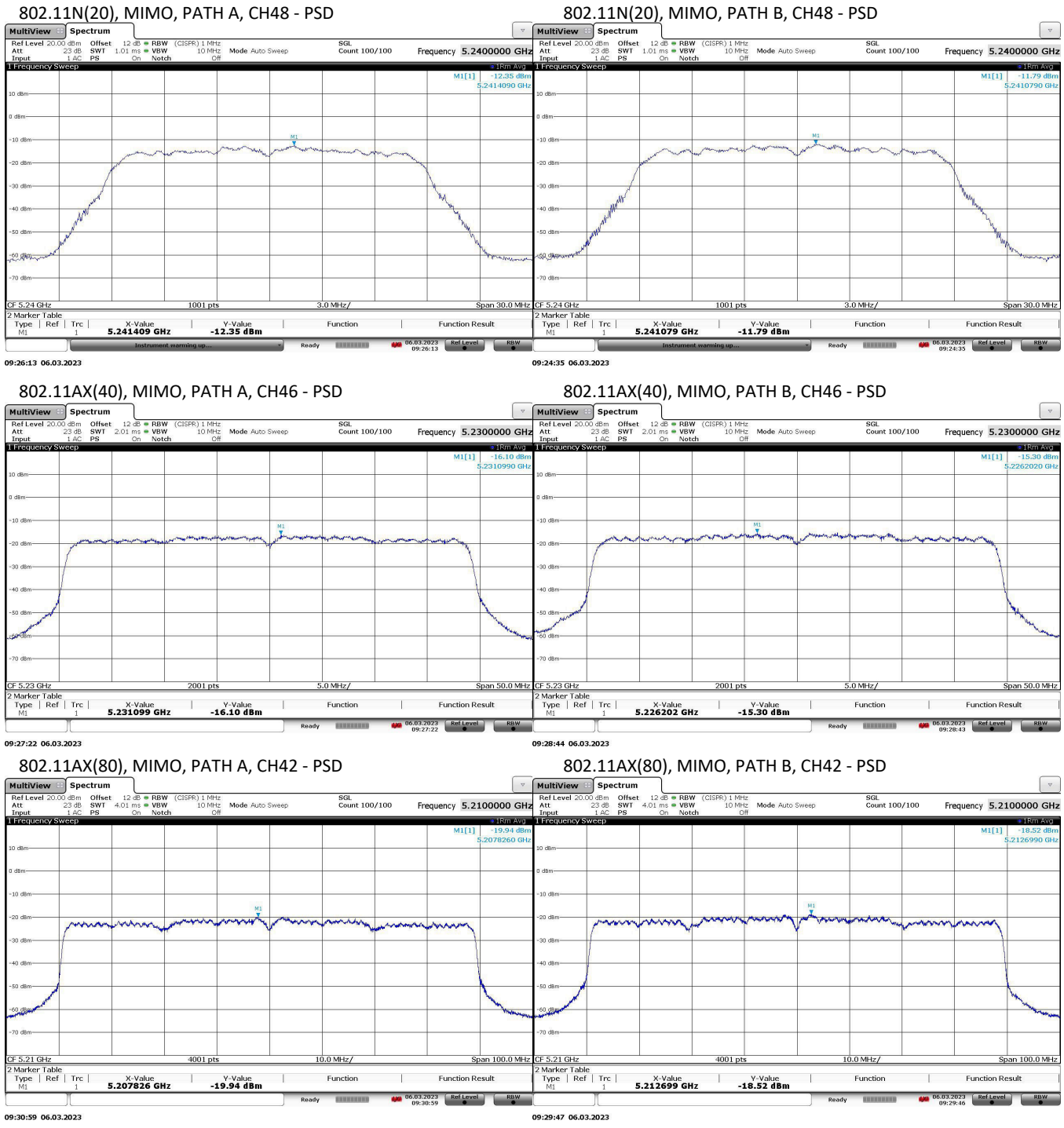

Figure 8: Example Power Spectral Density Plots.

4.3 Unintentional Emissions

4.3.1 Restricted Band Transmit Chain Spurious Emissions

The results for the measurement of transmit chain spurious emissions at the nominal voltage and temperature are provided in Table 8. Measurements are performed to 10 times the highest fundamental operating frequency.

Table 8(a): Transmit Chain Spurious Emissions.

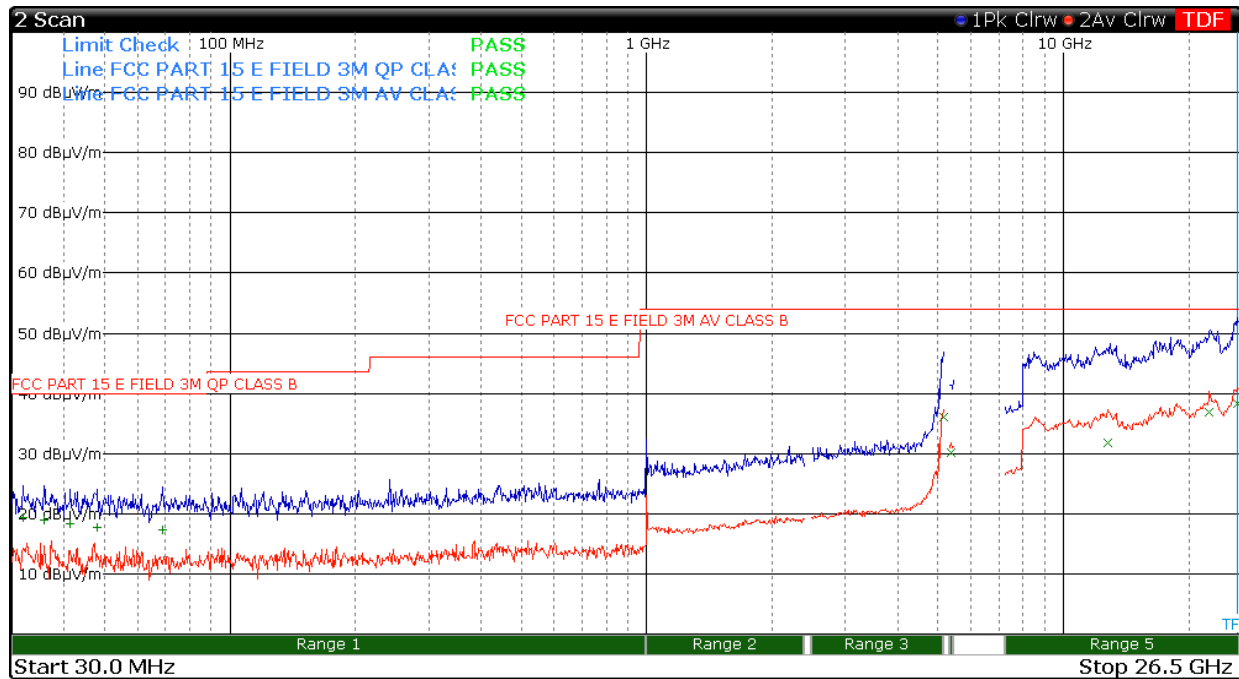

Frequency Range	Det	IF Bandwidth	Video Bandwidth	Test Date:	22-Feb-23
30 >= f > 1000 MHz	Pk/QPk	100 kHz	300 kHz	Test Engineer:	J. Brunett
f < 1000 MHz	Pk/Avg	1 MHz	3 MHz	EUT:	Ford SG5PHX
				Meas. Distance:	Conducted

Transmitter Spurious in Restricted Bands																FCC/IC	
#	Mode	Path A/B	Frequency Start MHz	Frequency Stop MHz	Output Power Pk dBm	Output Power Avg dBm	Ant Gain dBi	GR Factor dB	Avg Duty Factor dB	Calc. Pk dBuV/m	Limit Pk dBuV/m	Calc. Avg dBuV/m	Limit Qpk/Avg dBuV/m	EIRP Calc. Pk dBm / MHz	Limit dB	Pass	Comments
R1	Fundamental	Restricted Band Edge (Low Side)															
R2	AX20 SISO	A	5150.0	5150.0	-59.9	-70.2	8.8	0.0	0.4	44.1	74.0	34.2	54.0	-51.1		19.8	max all - L,M,H channels
R3	AX20 SISO	B	5150.0	5150.0	-61.2	-71.7	8.8	0.0	0.4	42.8	74.0	32.7	54.0	-52.4		21.3	max all - L,M,H channels
R4	Fundamental	Restricted Band Edge (High Side)															
R5	AX20 SISO	A	5350.0	5350.0	-60.0	-71.7	8.8	0.0	0.4	44.0	74.0	32.7	54.0	-51.2		21.3	max all - L,M,H channels
R6	AX20 SISO	B	5350.0	5350.0	-56.6	-68.8	8.8	0.0	0.4	47.4	74.0	35.6	54.0	-47.8		18.4	max all - L,M,H channels
R7																	
R8	AX20 SISO	max	30	88	-84.1		8.8	4.7	0.4	24.6			40	-70.6	-27	15.4	max all - L,M,H channels
R9	AX20 SISO	max	88	216	-85.6		8.8	4.7	0.4	23.1			43	-72.1	-27	19.9	max all - L,M,H channels
R10	AX20 SISO	max	216	1000	-84.6		8.8	4.7	0.4	24.1			46	-71.1	-27	21.9	max all - L,M,H channels
R11	AX20 SISO	max	1000.0	4000.0	-71.6	-82.0	8.8	0.0	0.4	32.4	74.0	22.4	54.0	-62.8	-27	31.6	max all - L,M,H channels
R15	AX20 SISO	max	4000.0	6000.0	-56.6	-68.8	8.8	0.0	0.4	47.4	74.0	35.6	54.0	-47.8	-27	18.4	max all - L,M,H channels
R16	AX20 SISO	max	6000.0	8400.0	-65.8	-75.4	8.8	0.0	0.4	38.2	74.0	29.0	54.0	-57.0	-27	25.0	max all - L,M,H channels
R17	AX20 SISO	max	8400.0	12500.0	-59.8	-71.4	8.8	0.0	0.4	44.2	74.0	33.0	54.0	-51.0	-27	21.0	max all - L,M,H channels
R18	AX20 SISO	max	12500.0	26500.0	-52.8	-62.4	8.8	0.0	0.4	51.2	74.0	42.0	54.0	-44.0	-27	12.0	max all - L,M,H channels
R19	AX20 SISO	max	26500.0	40000.0	-56.2		8.8	0.0	0.4	47.8	74.0		54.0	-47.4	-27	6.2	max all - L,M,H channels - noise

#	ROW	COLUMN	Comments
All	All	C1	All 20MHz SISO Modes (A20, N20, AC20, AX20) were evaluated. Worst case emissions found in AX20 mode as fully reported here.
All	All	C5/C6	Conducted measurements were made in line with DTS guidance 558074 D01 v5 r02 sections 8.5, 8.6, 8.7 / ANSI C63.10 11.10, 11.11, 11.12, 11.12.2.2(d) applied for MIMO.
All	All	C8	Ground Reflection Factor as described in ANSI C63.10-2013 section 11.12.2.2 (c)
All	All	C10/C12	Computed according to ANSI C63.10-2013 section 11.12.2.2 (e)

Table 8(b): Transmit Chain Spurious Emissions.

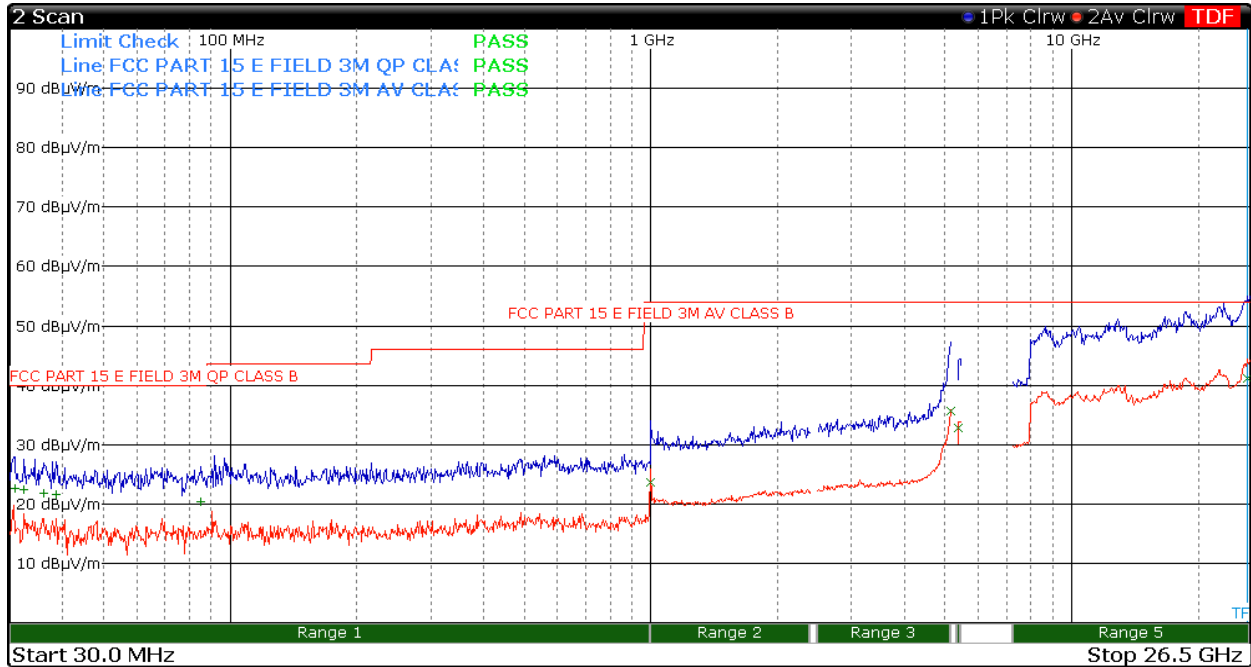

Frequency Range 30 >= f > 1000 MHz f < 1000 MHz	Det Pk/QPk Pk/Avg	IF Bandwidth 100 kHz 1 MHz	Video Bandwidth 300 kHz 3 MHz	Test Date: 22-Feb-23	Test Engineer: J. Brunett
				EUT: Ford SG5PHX	Meas. Distance: Conducted

Transmitter Spurious in Restricted Bands																FCC/IC	
#	Mode	Path A / B	Frequency		Output Power		Ant Gain dBi	GR Factor dB	Avg Duty Factor dB	Electric Field @ 3m				EIRP		Pass	Comments
			Start MHz	Stop MHz	Pk dBm	Avg dBm				Calc. Pk dBuV/m	Limit Pk dBuV/m	Calc. Avg dBuV/m	Limit Qpk/Avg dBuV/m	Calc. Pk dBm / MHz	Limit dB		
Fundamental Restricted Band Edge (Low Side)																	
R1	AX20 MIMO	A	5150.0	5150.0	-56.3	-69.1	8.8	0.0	0.8	47.7	74.0	35.7	54.0	-47.5	18.3	max all - L,M,H channels	
R3	AX20 MIMO	B	5150.0	5150.0	-57.7	-70.0	8.8	0.0	0.8	46.3	74.0	34.8	54.0	-48.9	19.2	max all - L,M,H channels	
Fundamental Restricted Band Edge (High Side)																	
R5	AX20 MIMO	A	5350.0	5350.0	-55.1	-67.7	8.8	0.0	0.8	48.9	74.0	37.1	54.0	-46.3	16.9	max all - L,M,H channels	
R6	AX20 MIMO	B	5350.0	5350.0	-55.4	-67.9	8.8	0.0	0.8	48.6	74.0	36.9	54.0	-46.6	17.1	max all - L,M,H channels	
R7																	
R8	AX20 MIMO	max	30	88	-83.8		8.8	4.7	0.8	24.9			40	-70.3	-27	15.1	max all - L,M,H channels
R9	AX20 MIMO	max	88	216	-84.6		8.8	4.7	0.8	24.1			43	-71.1	-27	18.9	max all - L,M,H channels
R10	AX20 MIMO	max	216	1000	-83.9		8.8	4.7	0.8	24.8			46	-70.4	-27	21.2	max all - L,M,H channels
R11	AX20 MIMO	max	1000.0	4000.0	-70.7	-80.7	8.8	0.0	0.8	33.3	74.0	24.1	54.0	-61.9	-27	29.9	max all - L,M,H channels
R15	AX20 MIMO	max	4000.0	6000.0	-55.1	-67.7	8.8	0.0	0.8	48.9	74.0	37.1	54.0	-46.3	-27	16.9	max all - L,M,H channels
R16	AX20 MIMO	max	6000.0	8400.0	-65.6	-76.0	8.8	0.0	0.8	38.4	74.0	28.8	54.0	-56.8	-27	25.2	max all - L,M,H channels
R17	AX20 MIMO	max	8400.0	12500.0	-59.0	-69.3	8.8	0.0	0.8	45.0	74.0	35.4	54.0	-50.2	-27	18.6	max all - L,M,H channels
R18	AX20 MIMO	max	12500.0	26500.0	-52.4	-62.4	8.8	0.0	0.8	51.6	74.0	42.4	54.0	-43.6	-27	11.6	max all - L,M,H channels
R19	AX20 MIMO	max	26500.0	40000.0	-56.6		8.8	0.0	0.8	51.2	74.0		54.0	-44.0	-27	2.8	max all - L,M,H channels - noise
#	C1	C2	C3	C4	C5	C6	C7	C8	C9	C10	C11	C12	C13	C14	C15	C16	C17
ROW	COLUMN																
All	C1	All 20MHz MIMO Modes (N20, AC20, AX20) were evaluated. Worst case emissions found in AX20 mode as fully reported here.															
All	C5/C6	Conducted measurements were made in line with DTS guidance 558074 D01 v5 r02 sections 8.5, 8.6, 8.7 / ANSI C63.10 11.10, 11.11, 11.12, 11.12.2(d) applied for MIMO.															
All	C8	Ground Reflection Factor as described in ANSI C63.10-2013 section 11.12.2.2 (c)															
All	C10/C12	Computed according to ANSI C63.10-2013 section 11.12.2.2 (e)															

Table 8(c): Transmit Chain Spurious Emissions.

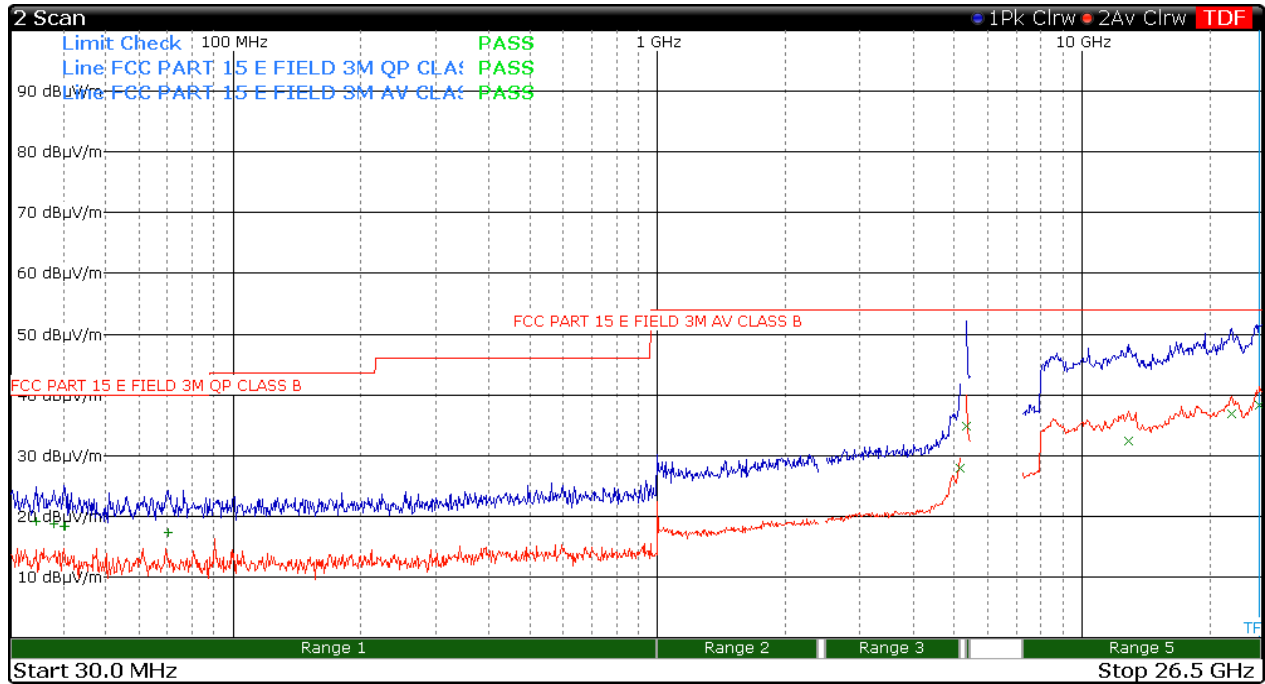

Frequency Range	Det	IF Bandwidth	Video Bandwidth	Test Date:	22-Feb-23
30 >= f > 1000 MHz	Pk/QPk	100 kHz	300 kHz	Test Engineer:	J. Brunett
f < 1000 MHz	Pk/Avg	1 MHz	3 MHz	EUT:	Ford SG5PHX
				Meas. Distance:	Conducted

Transmitter Spurious in Restricted Bands																FCC/IC	
#	Mode	Path A / B	Frequency		Output Power		Ant Gain dBi	GR Factor	Avg Duty Factor dB	Electric Field @ 3m				EIRP		Pass dB	Comments
			Start MHz	Stop MHz	Pk dBm	Avg dBm				Calc. Pk dBuV/m	Limit Pk dBuV/m	Calc. Avg dBuV/m	Limit Qpk/Avg dBuV/m	Calc. Pk dBm / MHz	Limit		
R1	Fundamental		Restricted Band Edge (Low Side)														
R2	AX40 SISO	A	5150.0	5150.0	-56.4	-69.7	8.8	0.0	0.7	47.6	74.0	35.0	54.0	-47.6		19.0	max all - L,M,H channels
R3	AX40 SISO	B	5150.0	5150.0	-59.2	-69.8	8.8	0.0	0.7	44.8	74.0	34.9	54.0	-50.4		19.1	max all - L,M,H channels
R4	Fundamental		Restricted Band Edge (High Side)														
R5	AX40 SISO	A	5350.0	5350.0	-57.3	-69.8	8.8	0.0	0.7	46.7	74.0	34.9	54.0	-48.5		19.1	max all - L,M,H channels
R6	AX40 SISO	B	5350.0	5350.0	-57.2	-69.0	8.8	0.0	0.7	46.8	74.0	35.7	54.0	-48.4		18.3	max all - L,M,H channels
R7																	
R8	AX40 SISO	max	30	88	-83.2		8.8	4.7	0.7	25.5			40	-69.7	-27	14.5	max all - L,M,H channels
R9	AX40 SISO	max	88	216	-84.8		8.8	4.7	0.7	23.9			43	-71.3	-27	19.1	max all - L,M,H channels
R10	AX40 SISO	max	216	1000	-84.3		8.8	4.7	0.7	24.4			46	-70.8	-27	21.6	max all - L,M,H channels
R11	AX40 SISO	max	1000.0	4000.0	-70.8	-81.3	8.8	0.0	0.7	33.2	74.0	23.4	54.0	-62.0	-27	30.6	max all - L,M,H channels
R15	AX40 SISO	max	4000.0	6000.0	-56.4	-69.0	8.8	0.0	0.7	47.6	74.0	35.7	54.0	-47.6	-27	18.3	max all - L,M,H channels
R16	AX40 SISO	max	6000.0	8400.0	-65.7	-76.1	8.8	0.0	0.7	38.3	74.0	28.6	54.0	-56.9	-27	25.4	max all - L,M,H channels
R17	AX40 SISO	max	8400.0	12500.0	-59.3	-69.9	8.8	0.0	0.7	44.7	74.0	34.8	54.0	-50.5	-27	19.2	max all - L,M,H channels
R18	AX40 SISO	max	12500.0	26500.0	-52.0	-62.0	8.8	0.0	0.7	52.0	74.0	42.7	54.0	-43.2	-27	11.3	max all - L,M,H channels
R19	AX40 SISO	max	26500.0	40000.0	-56.6		8.8	0.0	0.7	48.1	74.0		54.0	-47.1	-27	5.9	max all - L,M,H channels - noise
#	C1	C2	C3	C4	C5	C6	C7	C8	C9	C10	C11	C12	C13	C14	C15	C16	C17

ROW COLUMN

All C1 All 40MHz SISO Modes (N40, AC40, AX40) were evaluated. Worst case emissions found in AX40 mode as fully reported here.

All C5/C6 Conducted measurements were made in line with DTS guidance 558074 D01 v5 r02 sections 8.5, 8.6, 8.7 / ANSI C63.10 11.10, 11.11, 11.12, 11.12.2(d) applied for MIMO.

All C8 Ground Reflection Factor as described in ANSI C63.10-2013 section 11.12.2.2 (c)

All C10/C12 Computed according to ANSI C63.10-2013 section 11.12.2.2 (e)

Table 8(d): Transmit Chain Spurious Emissions.

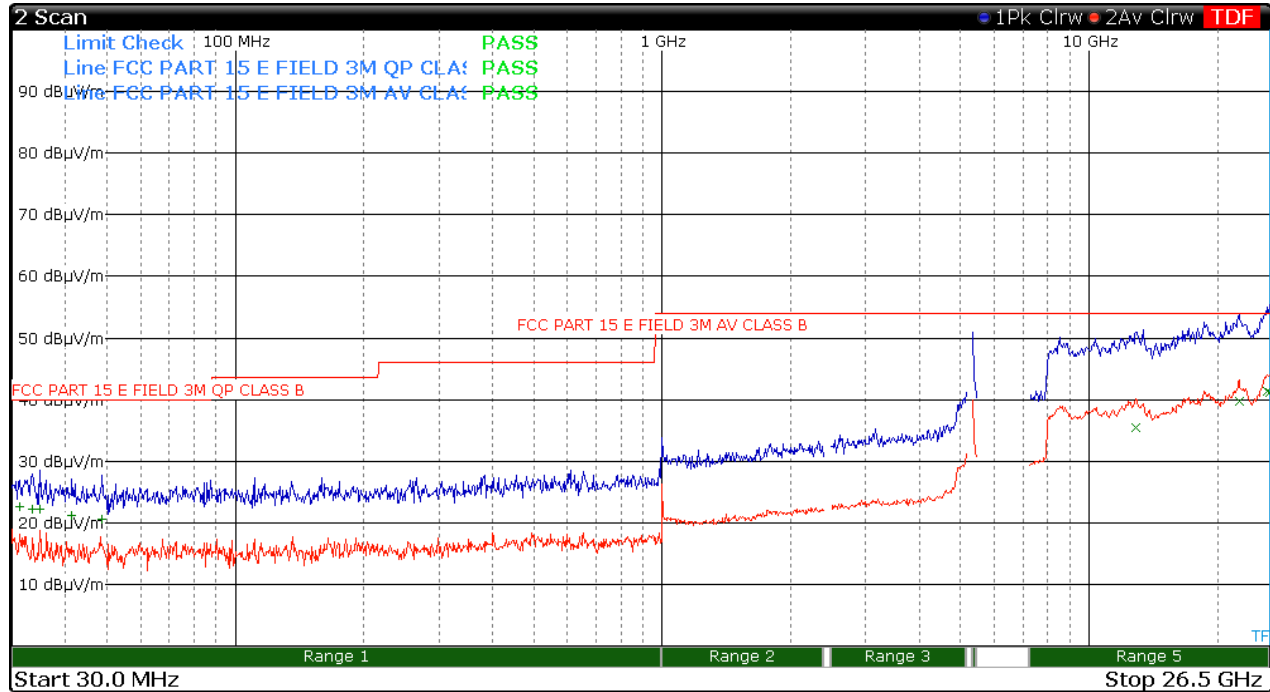

Frequency Range 30 >= f > 1000 MHz f < 1000 MHz	Det Pk/QPk Pk/Avg	IF Bandwidth 100 kHz 1 MHz	Video Bandwidth 300 kHz 3 MHz	Test Date: 22-Feb-23	Test Engineer: J. Brunett
				EUT: Ford SG5PHX	Meas. Distance: Conducted

Transmitter Spurious in Restricted Bands																FCC/IC	
#	Mode	Path A/B	Start MHz	Stop MHz	Output Power Pk dBm	Avg dBm	Ant Gain dBi	GR Factor dB	Avg Duty Factor	Calc. Pk dBuV/m	Limit Pk dBuV/m	Calc. Avg dBuV/m	Limit Qpk/Avg dBuV/m	EIRP Calc. Pk dBm/MHz	Limit dB	Pass	Comments
R1	Fundamental Restricted Band Edge (Low Side)																
R2	AC40 MIMO	A	5150.0	5150.0	-58.4	-71.3	8.8	0.0	1.0	45.6	74.0	33.7	54.0	-49.6		20.3	max all - L,M,H channels
R3	AC40 MIMO	B	5150.0	5150.0	-57.9	-70.8	8.8	0.0	1.0	46.1	74.0	34.2	54.0	-49.1		19.8	max all - L,M,H channels
R4	Fundamental Restricted Band Edge (High Side)																
R5	AC40 MIMO	A	5350.0	5350.0	-54.5	-66.9	8.8	0.0	1.0	49.5	74.0	38.1	54.0	-45.7		15.9	max all - L,M,H channels
R6	AC40 MIMO	B	5350.0	5350.0	-54.5	-67.1	8.8	0.0	1.0	49.5	74.0	37.9	54.0	-45.7		16.1	max all - L,M,H channels
R7																	
R8	AC40 MIMO	max	30	88	-83.1		8.8	4.7	1.0	25.6			40	-69.6	-27	14.4	max all - L,M,H channels
R9	AC40 MIMO	max	88	216	-84.7		8.8	4.7	1.0	24.0			43	-71.2	-27	19.0	max all - L,M,H channels
R10	AC40 MIMO	max	216	1000	-84.6		8.8	4.7	1.0	24.1			46	-71.1	-27	21.9	max all - L,M,H channels
R11	AC40 MIMO	max	1000.0	4000.0	-70.7	-81.4	8.8	0.0	1.0	33.3	74.0	23.5	54.0	-61.9	-27	30.5	max all - L,M,H channels
R15	AC40 MIMO	max	4000.0	6000.0	-54.5	-66.9	8.8	0.0	1.0	49.5	74.0	38.1	54.0	-45.7	-27	15.9	max all - L,M,H channels
R16	AC40 MIMO	max	6000.0	8400.0	-65.5	-76.2	8.8	0.0	1.0	38.5	74.0	28.8	54.0	-56.7	-27	25.2	max all - L,M,H channels
R17	AC40 MIMO	max	8400.0	12500.0	-59.1	-69.6	8.8	0.0	1.0	44.9	74.0	35.4	54.0	-50.3	-27	18.6	max all - L,M,H channels
R18	AC40 MIMO	max	12500.0	26500.0	-52.7	-63.7	8.8	0.0	1.0	51.3	74.0	41.3	54.0	-43.9	-27	12.7	max all - L,M,H channels
R19	AC40 MIMO	max	26500.0	40000.0	-56.6		8.8	0.0	1.0	51.4	74.0		54.0	-43.8	-27	2.6	max all - L,M,H channels - noise
#	C1	C2	C3	C4	C5	C6	C7	C8	C9	C10	C11	C12	C13	C14	C15	C16	C17

ROW COLUMN

All C1 All 40MHz MIMO Modes (N40, AC40, AX40) were evaluated. Worst case emissions found in AC40 mode as fully reported here.

All C5/C6 Conducted measurements were made in line with DTS guidance 558074 D01 v5 r02 sections 8.5, 8.6, 8.7 / ANSI C63.10 11.10, 11.11, 11.12, 11.12.2.2(d) applied for MIMO.

All C8 Ground Reflection Factor as described in ANSI C63.10-2013 section 11.12.2.2 (c)

All C10/C12 Computed according to ANSI C63.10-2013 section 11.12.2.2 (e)

Table 8(e): Transmit Chain Spurious Emissions.

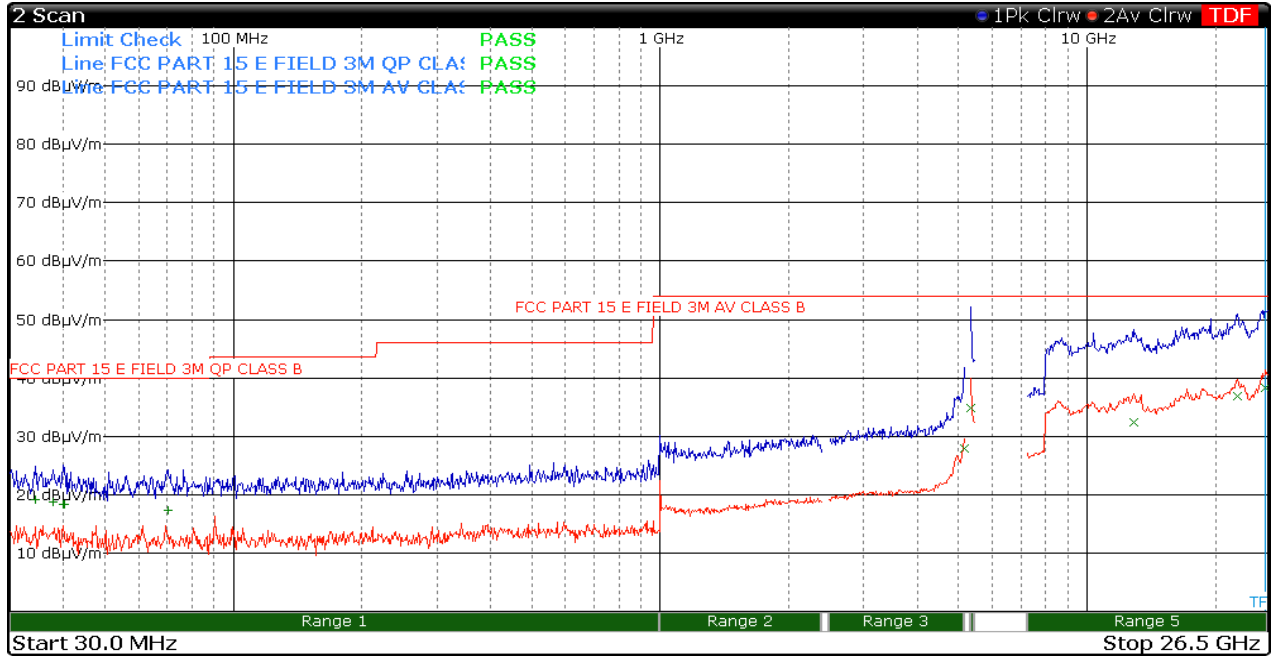

Frequency Range Det IF Bandwidth Video Bandwidth
 30 >= f > 1000 MHz Pk/QPk 100 kHz 300 kHz
 f < 1000 MHz Pk/Avg 1 MHz 3 MHz

Test Date: 22-Feb-23
 Test Engineer: J. Brunett
 EUT: Ford SG5PHX
 Meas. Distance: Conducted

Transmitter Spurious in Restricted Bands																FCC/IC	
#	Mode	Path A/B	Frequency		Output Power		Ant Gain dBi	GR Factor	Avg Duty Factor	Electric Field @ 3m				EIRP		Pass	Comments
			Start MHz	Stop MHz	Pk dBm	Avg dBm				Calc. Pk dBuV/m	Limit Pk dBuV/m	Calc. Avg dBuV/m	Limit Qpk/Avg dBuV/m	Calc. Pk dBm / MHz	Limit dB		
R1	Fundamental		Restricted Band Edge (Low Side)														
R2	AX80 SISO	A	5150.0	5150.0	-56.4	-69.6	8.8	0.0	0.9	47.6	74.0	35.3	54.0	-47.6	18.8	max all - L,M,H channels	
R3	AX80 SISO	B	5150.0	5150.0	-59.2	-68.7	8.8	0.0	0.9	44.8	74.0	36.2	54.0	-50.4	17.8	max all - L,M,H channels	
R4	Fundamental		Restricted Band Edge (High Side)														
R5	AX80 SISO	A	5350.0	5350.0	-58.6	-70.6	8.8	0.0	0.9	45.4	74.0	34.3	54.0	-49.8	19.7	max all - L,M,H channels	
R6	AX80 SISO	B	5350.0	5350.0	-57.9	-70.0	8.8	0.0	0.9	46.1	74.0	34.9	54.0	-49.1	19.1	max all - L,M,H channels	
R7																	
R8	AX80 SISO	max	30	88	-83.3		8.8	4.7	0.9	25.4			40	-69.8	-27	14.6	max all - L,M,H channels
R9	AX80 SISO	max	88	216	-85.5		8.8	4.7	0.9	23.2			43	-72.0	-27	19.8	max all - L,M,H channels
R10	AX80 SISO	max	216	1000	-83.7		8.8	4.7	0.9	25.0			46	-70.2	-27	21.0	max all - L,M,H channels
R11	AX80 SISO	max	1000.0	4000.0	-71.2	-82.0	8.8	0.0	0.9	32.8	74.0	22.9	54.0	-62.4	-27	31.1	max all - L,M,H channels
R15	AX80 SISO	max	4000.0	6000.0	-56.4	-74.9	8.8	0.0	0.9	47.6	74.0	30.0	54.0	-47.6	-27	24.0	max all - L,M,H channels
R16	AX80 SISO	max	6000.0	8400.0	-65.1	-75.5	8.8	0.0	0.9	38.9	74.0	29.4	54.0	-56.3	-27	24.6	max all - L,M,H channels
R17	AX80 SISO	max	8400.0	12500.0	-59.2	-69.5	8.8	0.0	0.9	44.8	74.0	35.4	54.0	-50.4	-27	18.6	max all - L,M,H channels
R18	AX80 SISO	max	12500.0	26500.0	-52.6	-62.7	8.8	0.0	0.9	51.4	74.0	42.2	54.0	-43.8	-27	11.8	max all - L,M,H channels
R19	AX80 SISO	max	26500.0	40000.0	-56.6		8.8	0.0	0.9	48.3	74.0		54.0	-46.9	-27	5.7	max all - L,M,H channels - noise
#	C1	C2	C3	C4	C5	C6	C7	C8	C9	C10	C11	C12	C13	C14	C15	C16	C17

ROW COLUMN
 All C1 All 80MHz SISO Modes (AC80, AX80) were evaluated. Worst case emissions found in AX80 mode as fully reported here.
 All C5/C6 Conducted measurements were made in line with DTS guidance 558074 D01 v5 r02 sections 8.5, 8.6, 8.7 / ANSI C63.10 11.10, 11.11, 11.12. 11.12.2(d) applied for MIMO.
 All C8 Ground Reflection Factor as described in ANSI C63.10-2013 section 11.12.2.2 (c)
 All C10/C12 Computed according to ANSI C63.10-2013 section 11.12.2.2 (e)

Table 8(f): Transmit Chain Spurious Emissions.

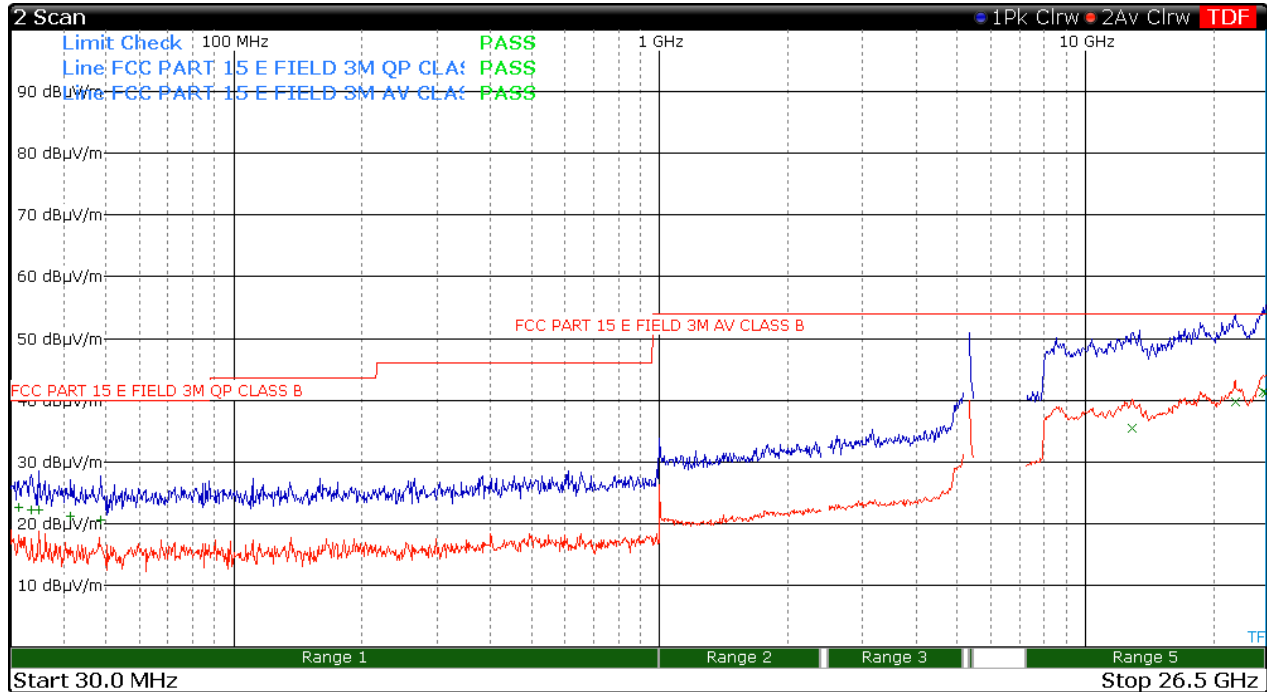

Frequency Range 30 >= f > 1000 MHz f < 1000 MHz	Det Pk/QPk Pk/Avg	IF Bandwidth 100 kHz 1 MHz	Video Bandwidth 300 kHz 3 MHz	Test Date: 22-Feb-23
				Test Engineer: J. Brunett
				EUT: Ford SG5PHX
				Meas. Distance: Conducted

Transmitter Spurious in Restricted Bands																FCC/IC	
#	Mode	Path A/B	Start MHz	Stop MHz	Output Power Pk dBm	Avg dBm	Ant Gain dBi	GR Factor dB	Avg Duty Factor dB	Calc. Pk dBuV/m	Limit Pk dBuV/m	Calc. Avg dBuV/m	Limit Qpk/Avg dBuV/m	EIRP Calc. Pk dBm / MHz	Limit dB	Pass	Comments
R1	Fundamental Restricted Band Edge (Low Side)																
R2	AX80 MIMO	A	5150.0	5150.0	-58.0	-70.0	8.8	0.0	0.8	46.0	74.0	34.8	54.0	-49.2	19.2	max all - L,M,H channels	
R3	AX80 MIMO	B	5150.0	5150.0	-57.2	-69.7	8.8	0.0	0.8	46.8	74.0	35.1	54.0	-48.4	18.9	max all - L,M,H channels	
R4	Fundamental Restricted Band Edge (High Side)																
R5	AX80 MIMO	A	5350.0	5350.0	-57.3	-69.7	8.8	0.0	0.8	46.7	74.0	35.1	54.0	-48.5	18.9	max all - L,M,H channels	
R6	AX80 MIMO	B	5350.0	5350.0	-56.4	-68.7	8.8	0.0	0.8	47.6	74.0	36.1	54.0	-47.6	17.9	max all - L,M,H channels	
R7																	
R8	AX80 MIMO	max	30	88	-83.2		8.8	4.7	0.8	25.5			40	-69.7	-27	14.5	max all - L,M,H channels
R9	AX80 MIMO	max	88	216	-85.6		8.8	4.7	0.8	23.1			43	-72.1	-27	19.9	max all - L,M,H channels
R10	AX80 MIMO	max	216	1000	-84.5		8.8	4.7	0.8	24.2			46	-71.0	-27	21.8	max all - L,M,H channels
R11	AX80 MIMO	max	1000.0	4000.0	-71.3	-81.2	8.8	0.0	0.8	32.7	74.0	23.7	54.0	-62.5	-27	30.3	max all - L,M,H channels
R15	AX80 MIMO	max	4000.0	6000.0	-56.4	-74.8	8.8	0.0	0.8	47.6	74.0	30.0	54.0	-47.6	-27	24.0	max all - L,M,H channels
R16	AX80 MIMO	max	6000.0	8400.0	-65.2	-75.5	8.8	0.0	0.8	38.8	74.0	29.4	54.0	-56.4	-27	24.6	max all - L,M,H channels
R17	AX80 MIMO	max	8400.0	12500.0	-59.3	-69.3	8.8	0.0	0.8	44.7	74.0	35.5	54.0	-50.5	-27	18.5	max all - L,M,H channels
R18	AX80 MIMO	max	12500.0	26500.0	-51.8	-62.0	8.8	0.0	0.8	52.2	74.0	42.8	54.0	-43.0	-27	11.2	max all - L,M,H channels
R19	AX80 MIMO	max	26500.0	40000.0	-56.6		8.8	0.0	0.8	51.2	74.0		54.0	-44.0	-27	2.8	max all - L,M,H channels - noise

#	C1	C2	C3	C4	C5	C6	C7	C8	C9	C10	C11	C12	C13	C14	C15	C16	C17
ROW	COLUMN																
All	C1	All 80MHz MIMO Modes (AC80, AX80) were evaluated. Worst case emissions found in AX80 mode as fully reported here.															
All	C5/C6	Conducted measurements were made in line with DTS guidance 558074 D01 v5 r02 sections 8.5, 8.6, 8.7 / ANSI C63.10 11.10, 11.11, 11.12, 11.12.2.2(d) applied for MIMO.															
All	C8	Ground Reflection Factor as described in ANSI C63.10-2013 section 11.12.2.2 (c)															
All	C10/C12	Computed according to ANSI C63.10-2013 section 11.12.2.2 (e)															

4.3.2 OOB Transmit Chain Spurious Emissions

The results for the measurement of transmit chain spurious emissions relative to the fundamental in a 1 MHz receiver bandwidth (at the nominal voltage and temperature) in the worst cases are provided in Figure 9 below.

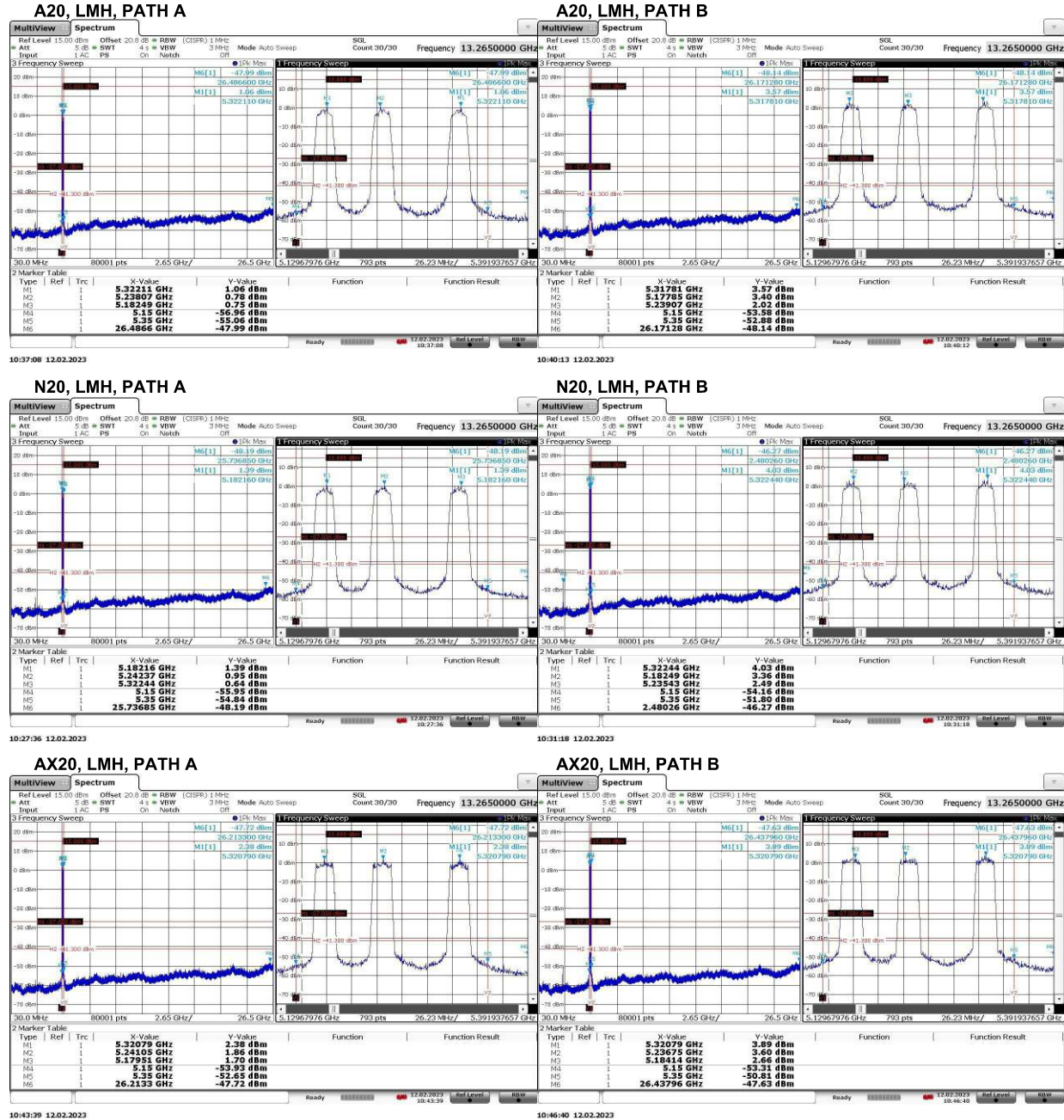

Figure 9(a): Worst Case Transmitter OOB Emissions Measured.

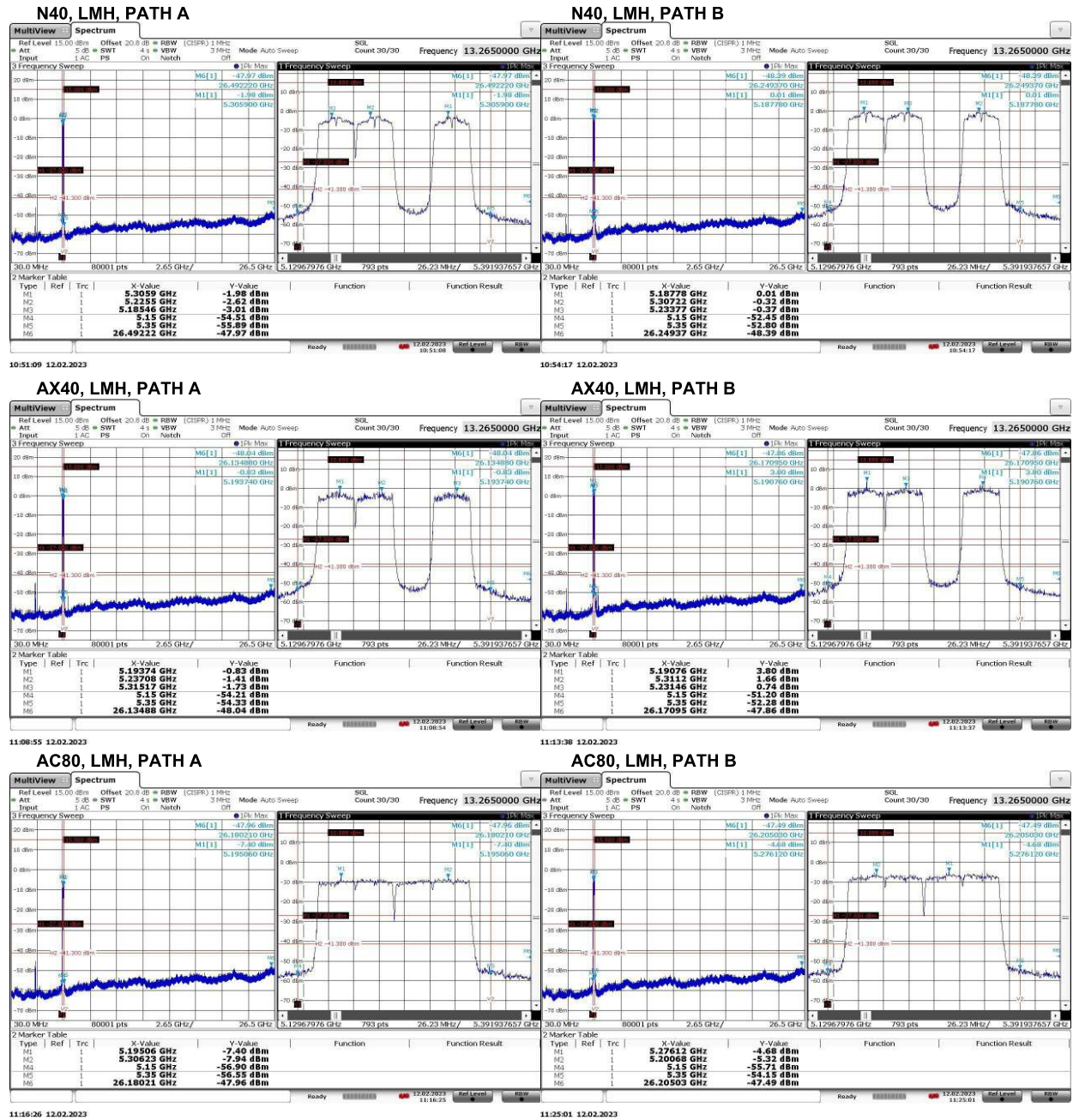

Figure 9(b): Worst Case Transmitter OOB Emissions Measured.

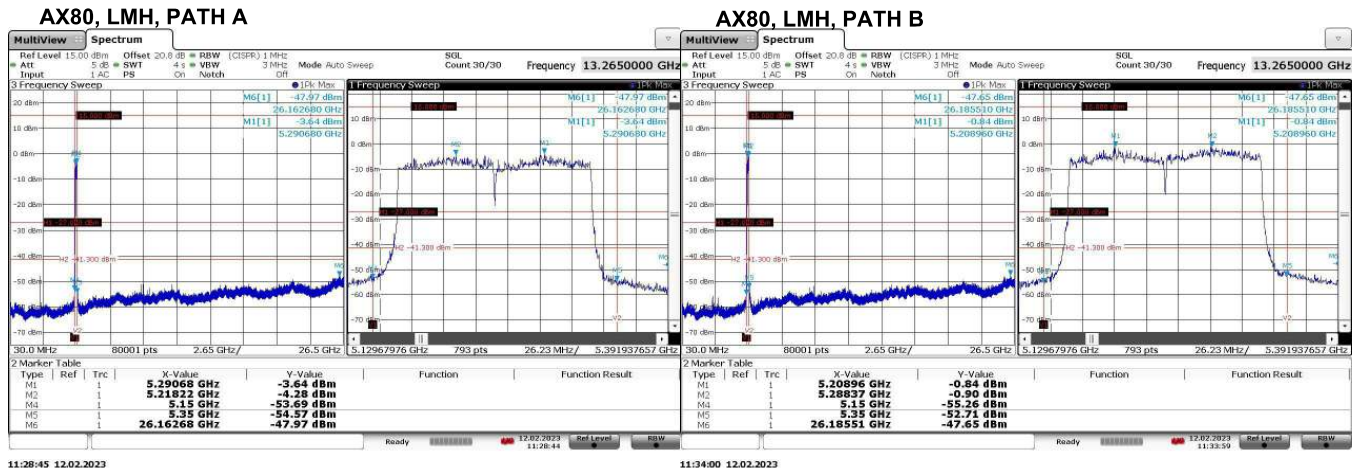

Figure 9(c): Worst Case Transmitter OOB Emissions Measured.

5 Measurement Uncertainty and Accreditation Documents

The maximum values of measurement uncertainty for the laboratory test equipment and facilities associated with each test are given in the table below. This uncertainty is computed for a 95.45% confidence level based on a coverage factor of $k = 2$.

Table 9: Measurement Uncertainty.

Measured Parameter	Measurement Uncertainty [†]
Radio Frequency	$\pm(f_{Mkr}/10^7 + RBW/10 + (SPN/(PTS - 1))/2 + 1 \text{ Hz})$
Conducted Emm. Amplitude	$\pm 1.9 \text{ dB}$
Radiated Emm. Amplitude ($f < 30 \text{ MHz}$)	$\pm 3.1 \text{ dB}$
Radiated Emm. Amplitude (30 – 200 MHz)	$\pm 4.0 \text{ dB}$
Radiated Emm. Amplitude (200 – 1000 MHz)	$\pm 5.2 \text{ dB}$
Radiated Emm. Amplitude ($f > 1000 \text{ MHz}$)	$\pm 3.7 \text{ dB}$

[†]Ref: CISPR 16-4-2:2011+A1:2014



Figure 10: Accreditation Documents