



Product Service

**Choose certainty.
Add value.**

Report On

Limited Testing of the
Orolia Limited
Fastfind PLB 220 – Z423
In accordance with Cospas-Sarsat T.007

Document 75942209 Report 14 Issue 3

December 2018



Product Service

TÜV SÜD Product Service, Octagon House, Concorde Way, Segensworth North,
Fareham, Hampshire, United Kingdom, PO15 5RL
Tel: +44 (0) 1489 558100. Website: www.tuv-sud.co.uk

REPORT ON

Limited Testing of the
Orolia Limited
Fastfind PLB 220 – Z423

Document 75942209 Report 14 Issue 3

December 2018

PREPARED FOR

Orolia Limited
Silver Point
Airport Service Road
Portsmouth
PO3 5PB

PREPARED BY

A handwritten signature in black ink that reads 'Jones'.

Sarah Jones
Project Manager

APPROVED BY

A handwritten signature in blue ink that reads 'Russell'.

Matthew Russell
Authorised Signatory

DATED

18 December 2018





CONTENTS

Section		Page No
1	REPORT SUMMARY	3
1.1	Introduction	4
1.2	Application Form.....	5
1.3	Product Information	13
1.4	Test Locations	17
1.5	Modifications.....	17
1.6	Report Modification Record	17
2	TEST DETAILS	18
2.1	Power Output.....	23
2.2	Digital Message	24
2.3	Self-test Modes.....	26
2.4	Operating Lifetime at Minimum Temperature	29
2.5	Satellite Qualitative Tests	43
2.6	Beacon Antenna Test (EIRP Re-Calculation Only)	45
2.7	Navigation System Test.....	48
3	TEST EQUIPMENT USED	51
3.1	Test Equipment.....	52
4	PHOTOGRAPHS.....	54
4.1	Photographs of Equipment Under Test (EUT)	55
5	ACCREDITATION, DISCLAIMERS AND COPYRIGHT.....	58
5.1	Accreditation, Disclaimers and Copyright.....	59
ANNEX A	Manufacturer Supplied Data.....	A.2



Product Service

SECTION 1

REPORT SUMMARY

Limited Testing of the
Orolia Limited
Fastfind PLB 220 - Z423



Product Service

1.1 INTRODUCTION

The information contained in this report is intended to show verification of the Orolia Limited, Fastfind PLB 220 - Z423 to limited requirements of Cospas-Sarsat T.007.

Objective	To perform Limited Testing to determine the Equipment Under Test's (EUT's) compliance with the Test Specification, for the series of tests carried out.
Manufacturer	Orolia Limited
Model Number(s)	Fastfind PLB 220 - Z423
Serial Number(s)	#10 #18 #13
Number of Samples Tested	3
Test Specification/Issue/Date	Cospas-Sarsat T.007 Issue 5 - Rev 1 February 2018
Date of Receipt of Test Samples	22 March 2018
Order Number	24016 / 25587
Date	07-Aug-2018 / 29-Oct-2018
Start of Test	27 September 2018
Finish of Test	15 October 2018
Name of Engineer(s)	M Hardy N Grigsby
Related Documents	Cospas-Sarsat T.001 Issue 4 Rev 2 Feb 2018 Cospas-Sarsat T.IP (TCXO) Issue 1 Rev 5 Oct 2013
Cospas-Sarsat Case Ref	2018-10
TUV SUD original Testing Ref	75942209 Report 1

After the above report was issued the EUT was modified by the Manufacturer (MS1 as presented in this document); the limited test results in this report are repeat measurements to demonstrate continued compliance with Cospas Sarsat T.007. 75942209 Report 1 relates to the original testing.



1.2 APPLICATION FORM

G.1 INFORMATION PROVIDED BY THE BEACON MANUFACTURER

Beacon Manufacturer and Beacon Model

Beacon Manufacturer	Orovia Ltd
Beacon Model Name	Fastfind PLB 220
Additional Beacon Model Names	Z423

Beacon Type and Operational Configurations

Beacon Type	Beacon used while:	Tick where appropriate
EPIRB Float Free	Floating in water or on deck or in a safety raft	
EPIRB Non-Float Free (automatic and manual activation)	Floating in water or on deck or in a safety raft	
EPIRB Non-Float Free (manual activation only)	Floating in water or on deck or in a safety raft	
EPIRB Float Free with VDR	Floating in water or on deck or in a safety raft	
PLB	On ground and above ground	X
	On ground and above ground and floating in water	
ELT Survival	On ground and above ground	
	On ground and above ground and floating in water	
ELT Auto Fixed	Fixed ELT with aircraft external antenna	
ELT(DT)	Distress Tracking ELT with aircraft external antenna	
ELT Auto Portable	In aircraft with an external antenna	
	On ground, above ground, or in a safety raft with an integrated antenna	
ELT Auto Deployable	Deployable ELT with attached antenna	
Other (specify)		



Beacon Characteristics

Characteristic	Specification
Operating frequency (406 MHz operating channel = 406.xxx)	406.031 MHz
Operating temperature range	Tmin= -20°C Tmax= +55°C
Temperature, at which minimum duration of continuous operation is expected (Submit C/S T.007 Section 5, part s, if applicable)	-20°C
Operating lifetime	24 hours
Beacon power supply type (internal non-rechargeable, internal re-chargeable, external, combined, other)	Internal non-rechargeable
External power supply parameters (AC/DC and nominal voltage)	N/A
Is external power supply needed to energise the beacon or its ancillary devices in any of operational modes (N/A or Yes or No)	N/A
Battery cell chemistry	Lithium Manganese Dioxide
Battery cell model name, cell size, number of cells in a battery pack, and details of the battery pack electrical configuration	GPCR123A x4 cells in series
Battery cell manufacturer	GP
Battery pack manufacturer and part number	Oroliia Ltd
Beacon manufacturers declared maximum allowed cell shelf-life (from date of cell manufacture to date of battery pack installation in the beacon)	1 year
Declared beacon battery replacement period (from date of installation in the beacon to expiry date marked on the beacon)	6 years
Oscillator type (e.g. OCXO, MCXO, TCXO)	TCXO
Oscillator manufacturer	Rakon
Oscillator model name/ part number	E7472LF
Oscillator satisfies long-term frequency stability requirements (Yes or No)	Yes
Antenna type: Integral or Other (e.g. External, Detachable – specify type)	Integral
Antenna manufacturer	Oroliia Ltd
Antenna part name and part number (OEM, if applicable, and beacon manufacturer's)	Fastfind PLB Antenna 91-206
Antenna cable assembly min/max RF- losses at 406 MHz, if applicable	N/A



Characteristic	Specification
Navigation device type (Internal, External or None)	Internal
Features in beacon that prevent degradation to 406 MHz signal or beacon lifetime resulting from a failure of navigation device or failure to acquire position data (Yes, No, or N/A)	Yes
Features in beacon that ensure erroneous position data is not encoded into the beacon message (Yes, No or N/A)	Yes
Navigation device capable of supporting global coverage (Yes, No or N/A)	Yes
Encoded position update capability (Yes, No, N/A) and	Yes
Encoded position update interval value (range)	> 5min to ~1h
For Internal Navigation Devices	
– Geodetic reference system (WGS 84 or GTRF)	WGS 84
– GNSS receiver cold start forced at every beacon activation (Yes or No)	Yes
– Navigation device manufacturer	UBLOX
– Navigation device model name and partNumber	NEO-M8N
– Internal navigation device antenna type(integrated, internal, external, passive/active) , manufacturer and model	Internal, taoglas, CGGP.18.2.A.02
– GNSSsystem supported (e.g. GPS, GLONASS, Galileo)	GPS, Galileo
For External Navigation Devices	
– Data protocol for GNSS receiver to beacon interface	N/A
– Physical interface for beacon to navigationdevice	
– Electrical interface for beacon to navigationdevice	
– Part number of the external navigation interface device (if applicable)	
– Navigation device model and manufacturer (if beacon designed to use specific devices)	



Self-Test Mode Characteristics:	Self-Test Mode	Optional GNSS Self-test Mode
– Activated by a separate switch/ separate switch position (Yes or No)	Yes	Yes
– Self-test/GNSS self-test mode switch automatically returns to normal position when released (Yes or No)	Yes	Yes
– Self-test/ GNSS self-test activation can cause an operational mode transmission (Yes or No)	No	No
– Results in transmission of a single self-test burst only, regardless of how long the self-test activation mechanism is applied (Yes or No)	Yes	Yes
– Results of self-test/ GNSS self-test are indicated by (provide details, e.g. Pass / Fail indicator light, strobe light, etc.)	Pass/Fail LED	Pass/Fail LED
– The content of the encoded position data fields of the self-test message has default values	Yes	N/A
– Performs an internal check and indicates that RF-power is being emitted at 406 MHz and 121.5 MHz, if beacon includes a 121.5 Hz homer (Yes or No)	Yes	No
– Self-test results in transmission of a signal other than at 406 MHz (Yes & details or No)	Yes (121.5 MHz)	No
– Self-test can be activated directly at beacon (Yes or No)	Yes	Yes
– List of Items checked by self-test	406/121.5 power, GNSS receiver, battery	GNSS position fix, GNSS self test limit
– Self-test/ GNSS self-test 406 MHz burst duration (440 or 520 ms)	520 ms	520 ms
– Self-test message length format flag in bit 25, (“0” or “1”)	“1”	“1”
– Maximum duration of a self-test mode, sec	17 s	320 s
– Maximum recommended number of self-tests / <i>GNSS self-tests</i> during battery pack replacement period (as applicable)	60	10
– Distinct indication of self-test start (Yes or No)	Yes	Yes
– Indication of self-test results(Yes or No)	Yes	Yes
– Distinct indication of insufficient battery capacity (Yes or No)	Yes	Yes
– Automatic termination of self-test mode immediately after completion of the self-test cycle (Yes or No)	Yes	Yes



Self-Test Mode Characteristics:	Self-Test Mode	Optional GNSS Self-test Mode
– GNSS Self-test results in transmission of a single burst, irrespectively of the test result (Yes or No)	N/A	Yes
– Self-test/ GNSS self-test can be activated from beacon remote activation points (Yes & details or No)	No	No
– List all methods of Self-test mode and GNSS Self-test modes activation. Provide details on a separate sheet to describe	Press TEST button >2s and <10s	Press & hold TEST button for 10 s
Message Coding Protocols:	(x) Tick the boxes below against the intended protocol options	
User Protocol (tick where appropriate)	<input type="checkbox"/>	Maritime with MMSI
	<input type="checkbox"/>	Maritime with Radio Call Sign
	<input type="checkbox"/>	EPIRB Float Free with Serial Number
	<input type="checkbox"/>	EPIRB Non Float Free with Serial Number
	<input type="checkbox"/>	Radio Call Sign
	<input type="checkbox"/>	Aviation
	<input type="checkbox"/>	ELT with Serial Number
	<input type="checkbox"/>	ELT with Aircraft Operator and Serial Number
	<input type="checkbox"/>	ELT with Aircraft 24-bit Address
	<input type="checkbox"/>	PLB with Serial Number
	<input type="checkbox"/>	National (Short Message Format)
	<input type="checkbox"/>	National (Long Message Format)
Standard Location Protocol (tick where appropriate)	<input checked="" type="checkbox"/>	EPIRB with MMSI
	<input checked="" type="checkbox"/>	EPIRB with Serial Number
	<input type="checkbox"/>	ELT with 24-bit Address
	<input type="checkbox"/>	ELT with Aircraft Operator Designator
	<input type="checkbox"/>	ELT with Serial Number
National Location Protocol (tick where appropriate)	<input checked="" type="checkbox"/>	PLB with Serial Number
	<input checked="" type="checkbox"/>	National Location: EPIRB
	<input type="checkbox"/>	National Location: ELT
ELT(DT) Location Protocol (tick where appropriate)	<input checked="" type="checkbox"/>	National Location: PLB
	<input type="checkbox"/>	ELT with Serial Number
	<input type="checkbox"/>	ELT with Aircraft Operator and Serial Number
RLS Location Protocol (tick where appropriate) *	<input type="checkbox"/>	ELT with Aircraft 24-bit Address
	<input type="checkbox"/>	EPIRB



	ELT
	PLB
User Location Protocol (tick where appropriate)	X Maritime with MMSI
	X Maritime with Radio Call Sign
	EPIRB Float Free with Serial Number
	X EPIRB Non Float Free with Serial Number
	X Radio Call Sign
	Aviation
	ELT with Serial Number
	ELT with Aircraft Operator and Serial Number
	ELT with Aircraft 24-bit Address
	X PLB with Serial Number
Beacon includes a homer transmitter(s) (Yes or No) - homer transmitter(s) frequency and power	Yes <input checked="" type="checkbox"/> 121.5 MHz 19 dBm Yes <input type="checkbox"/> 243.0 MHz _____ dBm Yes <input type="checkbox"/> AIS _____ dBm Yes <input type="checkbox"/> Other _____ MHz _____ dBm Description: _____
- homer transmitter(s) duty cycle	99.13 %
- duty cycle of homer swept tone	35 %
Beacon includes a high intensity flashing light (e.g. Strobe)	No
- light intensity	N/A
- flash rate	N/A
Beacon transmission repetition period satisfies C/S T.001 requirement that two beacon's repetition periods are not synchronised closer than a few seconds over 5 minute period, and the time intervals between transmissions are randomly distributed on the interval 47.5 to 52.5 seconds (Yes or No)	Yes
Other ancillary devices (e.g. voice transceiver, remote control, external audio and light indicators, external activation device). List details on a separate sheet if insufficient space to describe.	None
Beacon includes automatic activation mechanism (Yes or No). Specify type of automatic beacon activation mechanism	No



<p>Beacon includes a voice-transceiver (Yes or No)</p> <p>- provides prevention against continuous operation of voice transmitter (Yes or No), and if Yes specify:</p> <p>- maximum continuous voice-transmission duration (limit), minutes</p> <p>- Manufacturer-specified total duration of voice-transmitter operation during the declared rated lifetime ("On time"), (hrs)</p>	No
<p>Beacon includes features and functions not listed above, related or non-related to 406 MHz (Yes or No)</p> <p>List features and use a separate sheet if insufficient space</p>	No
Beacon model hardware part number (P/N) and version	Z423
Beacon model software/firmware P/N, version, date of issue/releases	1001767 issue A01
Beacon model printed circuit board P/N and version	1001488 issue A
<p>Known non-compliances with C/S T.001 requirements(Yes or No)</p> <p>If Yes, provide details (Submit C/S T.007 Section 5, part t, if applicable)</p>	No
Beacon Manufacturer Point of Contact (POC) for this Type Approval application:	<p>Name and Job Title: Erwan THOMAS Certification and Hardware Engineer</p> <p>Phone: +33 (0)2 91 02 49 83</p> <p>E-mail: erwan.thomas@corolia.com</p>

Dated: 11/10/18

Signed: 

Stephane JINCHBLEAU, RCD Manager and Marine Design Authority
(Name, Position and Signature of Beacon Manufacturer Representative)



Product Service

1.2.1 Information Provided by the Cospas-Sarsat Accepted Test Facility

Name and Location of Beacon Test Facility: TÜV SÜD Product Service, United Kingdom

Date of Submission for Testing: March 2018

Applicable C/S Standards:

Document	Issue	Revision	Date
C/S T.001	4	2	Feb-18
C/S T.007	5	1	Feb-18
C/S T.IP (TCXO)	1	5	Oct-13

I hereby confirm that the 406 MHz beacon described above has been successfully tested in accordance with the Cospas-Sarsat Type Approval Standard (C/S T.007) and complies with the Specification for Cospas-Sarsat 406 MHz Distress Beacons (C/S T.001) as demonstrated in the attached report.¹

Non-compliances:
None

Deviations:
None

Observations / Notes:

None

Signed: 

Name: Matthew Russell

Position Held: Authorised Signatory

Date: 18 December 2018

¹ If the test results do not indicate full compliance to the above standards, or deviations from the standard test procedures took place during type approval testing, the test laboratory shall modify this statement to identify discrepancies. A complete explanation of such discrepancies should be provided in the test report and the report references identified in this statement.

1.3 PRODUCT INFORMATION

1.3.1 Technical Description

The Equipment Under Test (EUT) was a Orolia Limited Fastfind PLB 220 - Z423 as shown in the photograph below. A full technical description can be found in the manufacturer's documentation.



Equipment Under Test

1.3.2 Physical Test Configuration

The Equipment Under Test (EUT) was operated using its own power source (internal battery). One EUT was configured so that the antenna port was connected to the 50 Ω test system using a coaxial cable. The test configuration for all tests is identical with the exception of Antenna Characteristics, Satellite Qualitative and Position Acquisition Time and Position Accuracy.

The second EUT was a fully packaged beacon, similar to the proposed production beacons equipped with its proper antenna. This EUT was used to perform Antenna Characteristics, Satellite Qualitative and Position Acquisition Time and Position Accuracy. The test configuration for these tests is a function of the beacon type and the operational environments supported by the beacon, as declared by the manufacturer.

System Configurations

Conducted Laboratory Tests

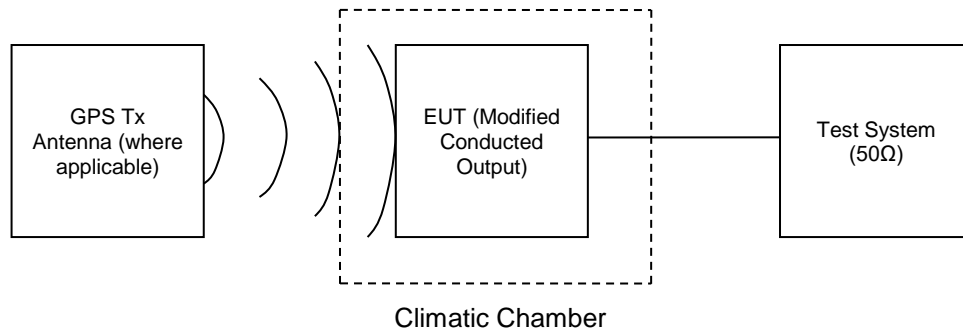

A.3.8.3 Navigation Test

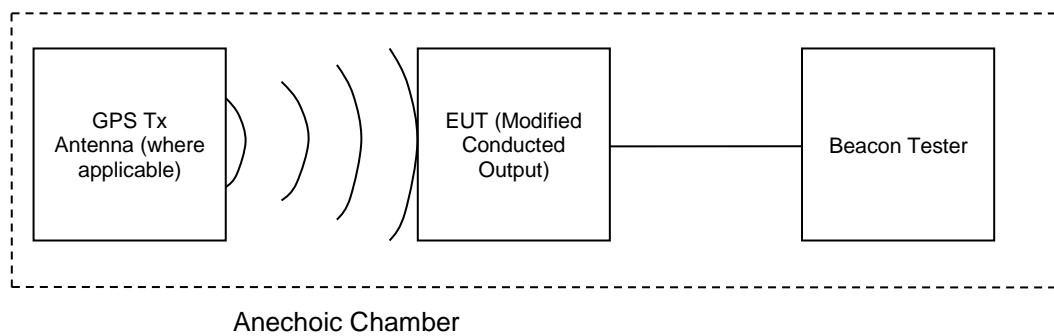

Battery Current Measurements

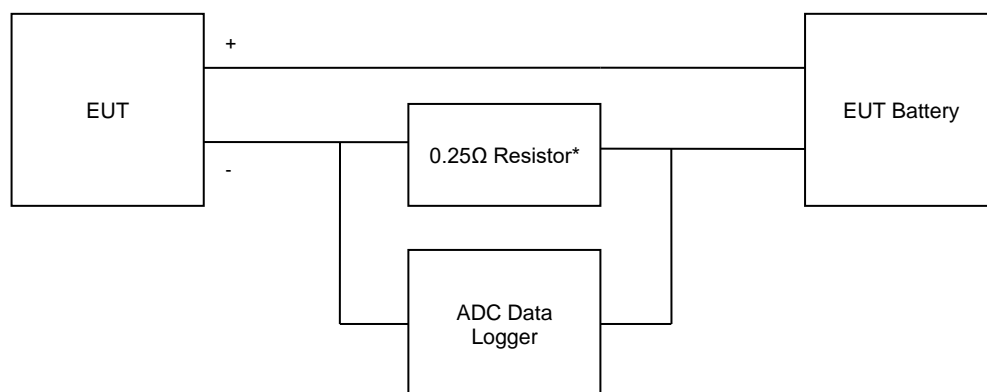

Note: The resistor in series with negative line of battery.

* Removed for Standby mode measurements

For other Navigation, Satellite and Antenna test configurations, see photographs in section 5 of this report.



Product Service

Further Information

Battery current measurements (see 'Operating lifetime', section 2.4) concluded that the 'worst case' (highest current) operating mode of the EUT was TUV Ref: A2 'ON at EUT switch (GPS search)'. All tests were carried out in this mode, subject to the EUT GPS receiver duty cycle (unless otherwise stated).

The EUT is fitted with an internal GPS receiver. From cold start, without GPS signal data present, the duty cycle of the receiver is as described in the manufacturer information. After a 15-minute warm up, electrical and functional tests were carried out for 30 minutes to ensure that measurements were made during periods when the GPS receiver was active and inactive.



Product Service

1.3.3 Modes of Operation

Modes of operation of the EUT during testing were as follows:

Off/Standby Mode

- Main switch to “OFF” position. (Activation button not depressed)
- No apparent activity

Self-test

- “TEST” button pressed and held for $> 2 < 10$ seconds
- List of items checked as per Customer Supplied Information (Application Form)
- Navigation data applied at ambient temperature

GNSS Self-test

- “TEST” button pressed and held for 10 seconds
- List of items checked as per Customer Supplied Information (Application Form)
- Navigation data applied as applicable (e.g. none applied for timeout, data applied for ‘fast acquisition’)

Operating

- “ON” button pressed until strobe light indicated activation
- 121 Homer active and offset
- GPS operating in normal duty cycle for the following navigation input conditions
- No navigation data applied (unless otherwise stated)



Product Service

1.4 TEST LOCATIONS

Satellite Qualitative/Navigation test A.3.8.2.1: Daedalus Airfield, Lee-on-the-Solent, Hants, UK
All other tests: Octagon House Laboratory, Fareham, Hampshire, UK

1.5 MODIFICATIONS

The table below details modifications made to the EUT during the test programme. The modifications incorporated during each test are recorded on the appropriate test pages.

Modification State	Description of Modification still fitted to EUT	Modification Fitted By	Date Modification Fitted
0	As supplied by the customer	Not Applicable	Not Applicable
1	Firmware update regarding : User Location test protocol 121 homing transmitter Firmware update regarding PIE	TUV SUD	06 August 2018

1.6 REPORT MODIFICATION RECORD

Issue 1 – First Issue.

Issue 2 – Inclusion of Antenna Characteristics EIRP re-calculation for MS1 $P_{t_{ambient}}$ and $P_{t_{EOL}}$.

Issue 3 – Correction of report issue number. Table of contents revised (header for section 2 added). Reference to Operating Lifetime section revised on page 15. Pre-battery discharge duration (operating) entry in summary table on page 20 revised to correct typographical error. 121MHz Homing Transmitter Power and 121MHz Homing Transmitter Frequency plots revised (legend corrected from minutes to seconds) – page 35. Clarification to battery discharge details – page 42.



Product Service

SECTION 2

TEST DETAILS

Limited Testing of the
Orolia Limited
Fastfind PLB 220 - Z423



Product Service

TEST RESULTS TABLE

Parameters to be Measured	Range of Specification	Units	Test Results			Comments	
			Tmin	Tamb	Tmax		
			(-20°C)	(+21°C)	(+55°C)		
1. Power Output							
Model: Fastfind PLB 220 - Z423, S/N: #10, TUV Ref: TSR1 and Modification State 1 – ambient temperature only							
Transmitter power output	(maximum) (minimum)	35 - 39	dBm	- -	37.26 37.14	- -	Only measurements at ambient temperature required.
Power output rise time	(maximum) (minimum)	< 5	ms	- -	0.07 0.06	- -	
Power output 1ms before burst	(maximum) (minimum)	< -10	dBm	- -	-37.37 -38.31	- -	
3. Digital Message Generator							
Model: Fastfind PLB 220 - Z423, S/N: #10, TUV Ref: TSR1 and Modification State 1 – ambient temperature only							
Repetition rate, T_R:							
Average T _R		$48.5 \leq T_{Ravg} \leq 51.5$	seconds	-	49.983	-	Only measurements at ambient temperature required.
Minimum T _R		$47.5 \leq T_{Rmin} \leq 48.0$	seconds	-	47.736	-	
Maximum T _R		$52.0 \leq T_{Rmax} \leq 52.5$	seconds	-	52.244	-	
Standard deviation		0.5 - 2.0	seconds	-	1.34	-	
Bit rate							
Minimum fb		≥ 396	bits/sec	-	400.01	-	
Maximum fb		≤ 404	bits/sec	-	400.02	-	
Total transmission time							
Short message	(maximum) (minimum)	435.6 - 444.4	ms	- -	N/A N/A	- -	
Long message	(maximum) (minimum)	514.8 - 525.2	ms	- -	522.64 522.69	- -	
Unmodulated carrier							
Minimum T1		≥ 158.4	ms	-	160.08	-	
Maximum T1		≤ 161.6	ms	-	160.13	-	
First burst delay		≥ 47.5	seconds	-	50	-	



Product Service

Parameters to be Measured	Range of Specification	Units	Test Results			Comments
			Tmin	Tamb	Tmax	
			(-20°C)	(+21°C)	(+55°C)	
8(a). Self-test Mode					Result: Pass	
Model: Fastfind PLB 220 - Z423, S/N: #13, TUV Ref: TSR5 and Modification State 1 (Insufficient battery capacity test only)						
Distinct indication of insufficient battery capacity	provided	Y / N		Y		See table F.E-5 in the test results section
10. Operating Lifetime at Minimum Temperature					Result: Pass	
Model: Fastfind PLB 220 - Z423, S/N: #10, TUV Ref: TSR1 and Modification State 1						
Pre-test battery discharge duration (operating) required		Hours	0.1653Ah			
Pre-test battery discharge duration (operating)		Hours	0.1753Ah			
Duration	>24	Hours	24.22 Hours at Tmin = -20°C			Time to first failure
Effective Operating Lifetime duration	>24	Hours	24.20 Hours at Tmin = -20°C			Time to last pass
Transmitted Frequency			Min	Max		Min/Max results are up to the manufacturer declared lifetime of 24hrs. MTS results exclude the first 30 mins of data (included in the test results section of this report).
Nominal value	C/S T.001	MHz	406.0310972	406.0311053		
Short-term stability	$\leq 2 \times 10^{-9}$	/100ms	2.349E-11	1.216E-10		
Medium-term stability – Slope	$(-1 \text{ to } +1) \times 10^{-9}$	/min	-1.684E-10	1.801E-10		
Medium-term stability – Residual frequency variation	$\leq 3 \times 10^{-9}$		6.088E-11	9.023E-10		
Transmitter power output	35 - 39	dBm	35.17	36.4		
Digital message	correct	P/F	P			
Homer transmitter continuous operation during the lifetime test		hours	26.07			
			Start of Test	End of Test		End of test taken as 24hrs (Manufacturer declared lifetime).
Homer frequency		MHz	121.649	121.649		
Homer peak power level		dBm	18.7	18.6		
Homer transmitter duty cycle		%	94.8	94.9		



Product Service

Parameters to be Measured	Range of Specification	Units	Test Results				Comments
14. Satellite Qualitative Tests						Result: Pass	
Model: Fastfind PLB 220 - Z423, S/N: #18, TUV Ref: TSR2 and Modification State 1 – configuration 8 only							
Test Configuration	As per C/S T.007		Configuration				
			5	6	7	8	
15 Hex ID Decoded by LUT	correct	P / F	-	-	-	P	
Doppler Location results with error \leq 5km	\geq 80	%	-	-	-	89.5	
16. Beacon Coding Software						Result: Pass	
Sample message for each coding option of the applicable coding types	correct	P / F	P*				*See Manufacturer Report in Annex A
Sample self-test message for each coding option of the applicable coding types	correct	P / F	P*				*See Manufacturer Report in Annex A



Product Service

Parameters to be Measured	Range of Specification	Units	Test Results			Comments
17. Navigation System						Result: Pass
Model: Fastfind PLB 220 - Z423, S/N: #10, TUV Ref: TSR1 and Modification State 1						
Model: Fastfind PLB 220 - Z423, S/N: #18, TUV Ref: TSR2 and Modification State 1 – (A.3.8.2 only)						
Location protocol	C/S T.001		National	Standard	User	One protocol only
Position data default values	correct	P / F	-	P	-	
Configuration 8						
Position accuracy - A.3.8.2.1	C/S T.001	m	-	25.6	-	
Position Acquisition Time - A.3.8.2.1	<10/1	min	-	0.83	-	
Position accuracy - A.3.8.2.2	C/S T.001	m	-	35.8	-	
Position Acquisition Time - A.3.8.2.2	<10/1	min	-	0.83	-	
Encoded position data update interval	>5	min	-	5.83	-	
Position clearance after deactivation	cleared	P / F	-	P	-	
Position data input update interval (as applicable)	20/1	Min	-	N/A	-	
Position data encoding	correct	P / F	-	P*	-	*See Manufacturer Report in Annex A
Retained last valid position after navigation input lost	240(±5)	min	-	239.15	-	
Default position data transmitted after 240(±5) minutes without valid position data	cleared	P / F	-	P	-	
Information on protection against beacon degradation due to navigation device, interface or signal failure or malfunction	provided	Y / N	Y			See Manufacturer information in Annex A



2.1 POWER OUTPUT

2.1.1 Specification

Cospas-Sarsat T.007, Clause A.2.1 (a)

2.1.2 Equipment Under Test and Modification State

Fastfind PLB 220 - Z423 S/N: #10 - Modification State 1 (ambient only)

2.1.3 Date of Test

27 September 2018

2.1.4 Test Equipment Used

The major items of test equipment used for the above tests are identified in Section 3.1.

2.1.5 Environmental Conditions

Ambient Temperature 21.4°C

Relative Humidity 47.4%

2.1.6 Test Results

Ambient Temperature

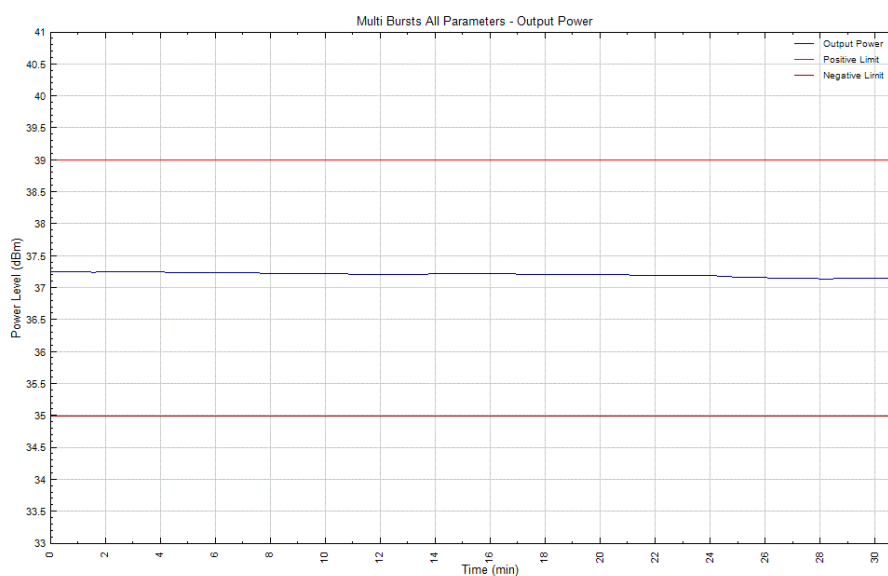

Summary

The EUT complies with clause A.3.2.2 of Cospas-Sarsat T.007.



Product Service

2.2 DIGITAL MESSAGE

2.2.1 Specification

Cospas-Sarsat T.007, Clause A.2.1 (b)

2.2.2 Equipment Under Test and Modification State

Fastfind PLB 220 - Z423 S/N: #10 - Modification State 1 (ambient only)

2.2.3 Date of Test

27 September 2018

2.2.4 Test Equipment Used

The major items of test equipment used for the above tests are identified in Section 3.1.

2.2.5 Environmental Conditions

Ambient Temperature 21.4°C
Relative Humidity 47.4%



2.2.6 Test Results

Test Duration: 30 minutes

No. of bursts: 38

Ambient Temperature

Message	FFFE2F8C9EF9C0637FDF83D15B783E0F66C		
Hex ID	193DF380C6FFBFF		
Position	None - Default Values		
Parameter	Bit	Data Bits	Decoded Value
Bit synchronization	1-15	1111111111111111	1111111111111111
Frame synchronization	16-24	000101111	000101111
Format Flag	25	1	1
Protocol Flag	26	0	0
Country Code	27-36	0011001001	Albania (Republic of)
Protocol Code	37-40	1110	Standard Test Location Protocol
Undefined	41-64	111110011100000001100011	111110011100000001100011
N/S	65	0	Default
Latitude Degrees	66-72	1111111	Default
Latitude Minutes	73-74	11	Default
E/W	75	0	Default
Longitude Degrees	76-83	11111111	Default
Longitude Minutes	84-85	11	Default
BCH Code (21 Bit)	86-106	000001111010001010110	000001111010001010110
Calculated BCH Code (21 Bit)	-	000001111010001010110	000001111010001010110
Supplementary Data Fixed	107-110	1101	1101
Encoded Position Data Source	111	1	Internal
121.5 MHz Homing	112	1	Yes
Delta Latitude +/-	113	1	Default
Delta Latitude Minutes	114-118	00000	Default
Delta Latitude Seconds	119-122	1111	Default
Delta Longitude +/-	123	1	Default
Delta Longitude Minutes	124-128	00000	Default
Delta Longitude Seconds	129-132	1111	Default
BCH Code (12 Bit)	133-144	011001101100	011001101100
Calculated BCH Code (12 Bit)	-	011001101100	011001101100

Summary

The EUT complies with clause A.3.1.4 of Cospas-Sarsat T.007.



Product Service

2.3 SELF-TEST MODES

2.3.1 Specification

Cospas-Sarsat T.007, Clause A.2.1 (h)

2.3.2 Equipment Under Test and Modification State

Fastfind PLB 220 - Z423 S/N: #13 - Modification State 1 (Insufficient battery capacity test only)

2.3.3 Date of Test

15 October 2018

2.3.4 Test Equipment Used

The major items of test equipment used for the above tests are identified in Section 3.1.

2.3.5 Environmental Conditions

Ambient Temperature 21.4°C
Relative Humidity 47.4%



2.3.6 Test Results

Self-test Mode

Ambient Temperature

Message	FF FED08C9EF9C0637FDFF83D15B783E0F66C		
Hex ID	193DF380C6FFBFF		
Position	None - Default Values		
Parameter	Bit	Data Bits	Decoded Value
Bit synchronization	1-15	1111111111111111	1111111111111111
Frame synchronization	16-24	011010000	011010000
Format Flag	25	1	1
Protocol Flag	26	0	0
Country Code	27-36	0011001001	Albania (Republic of)
Protocol Code	37-40	1110	Standard Test Location Protocol
Undefined	41-64	111110011100000001100011	111110011100000001100011
N/S	65	0	Default
Latitude Degrees	66-72	1111111	Default
Latitude Minutes	73-74	11	Default
E/W	75	0	Default
Longitude Degrees	76-83	11111111	Default
Longitude Minutes	84-85	11	Default
BCH Code (21 Bit)	86-106	000001111010001010110	000001111010001010110
Calculated BCH Code (21 Bit)	-	000001111010001010110	000001111010001010110
Supplementary Data Fixed	107-110	1101	1101
Encoded Position Data Source	111	1	Internal
121.5 MHz Homing	112	1	Yes
Delta Latitude +/-	113	1	Default
Delta Latitude Minutes	114-118	00000	Default
Delta Latitude Seconds	119-122	1111	Default
Delta Longitude +/-	123	1	Default
Delta Longitude Minutes	124-128	00000	Default
Delta Longitude Seconds	129-132	1111	Default
BCH Code (12 Bit)	133-144	011001101100	011001101100
Calculated BCH Code (12 Bit)	-	011001101100	011001101100

Note: Self-test at ambient temperature carried out with navigation data applied.



Testing Insufficient Battery Energy – Table F.E-5

Parameter	Units	Declared by beacon manufacturer	Verified and evaluated by accepted test facility	Notes
Minimum duration of continuous operation (C _{CO})	hours	24	Manufacturer declared	C _{CO} is declared in Annex G as "Operating Lifetime". C _{CO} is required for the test. Minimum duration of continuous operation (C _{CO})
Full Battery Pack Capacity (C _{BP})	hours	32	Manufacturer declared	If needed to calculate C _{SP-AMB}
Battery Pre-Operational Losses (C _{PO})	hours	3.5	Manufacturer declared	Corresponds to L _{CDC} , as defined in the Table F- E.2
Spare Battery Capacity at ambient temperature (C _{SP-AMB})	hours	4.5	Manufacturer declared	C _{SP-AMB} is required for the test, and shall be defined by testing (see Footnote 4 to section A.3.6.2.2), or by calculation, as follows: C_{SP-AMB} = C_{BP} – (C_{PO} + C_{CO})
Criteria and conditions to trigger PIE indication		Remaining capacity ≤ C _{CO} (As described above)	-	Description of PIE criteria and conditions to be met to trigger PIE indication. Use a separate sheet if needed
Step-1: battery pack discharge	hours	3	3.5 – 0.5	Battery discharge shall correspond to: C_{PO} - 30 minutes , or the value declared by the beacon manufacturer less 30 minutes
Step-1: beacon conditions (if applicable)			EUT operated in A4* mode with no GPS data present	Description of conditions recreated during the Step-1 for which the PIE criteria is not met
Step-1: observations of self-test indication			Self-test indication: 2 x strobe flash	Test facility observations of self-test indication: time, duration, type of indication
Step-2: battery pack discharge	hours	8.5	C _{PO} + C _{SP-AMB} + 30 minutes	Total battery discharge shall correspond to: C_{PO} + C_{SP-AMB} + 30 minutes or the value declared by the beacon manufacturer plus 30 minutes
Step-2: beacon conditions (if applicable)			EUT operated in A4* mode with no GPS data present	Description of conditions recreated during the Step-2 for which the PIE criteria is met
Step-2: observations of distinct PIE indication			Self-test indication: 1 x strobe flash	Test facility observations of PIE indication: time, duration, type of indication

* A4 corresponds to the operating mode referenced in the Battery Current measurements (Operating Lifetime) test results section.

Summary

The EUT complies with clause A.3.6 of Cospas-Sarsat T.007.



2.4 OPERATING LIFETIME AT MINIMUM TEMPERATURE

2.4.1 Specification

Cospas-Sarsat T.007, Clause A.2.3

2.4.2 Equipment Under Test and Modification State

Fastfind PLB 220 - Z423 S/N: #10 - Modification State 1

2.4.3 Date of Test

09 August 2018 – 10 August 2018

2.4.4 Test Equipment Used

The major items of test equipment used for the above tests are identified in Section 3.1.

2.4.5 Environmental Conditions

Ambient Temperature 22.9°C

Relative Humidity 28.3%

2.4.6 Test Results

Nominal Frequency

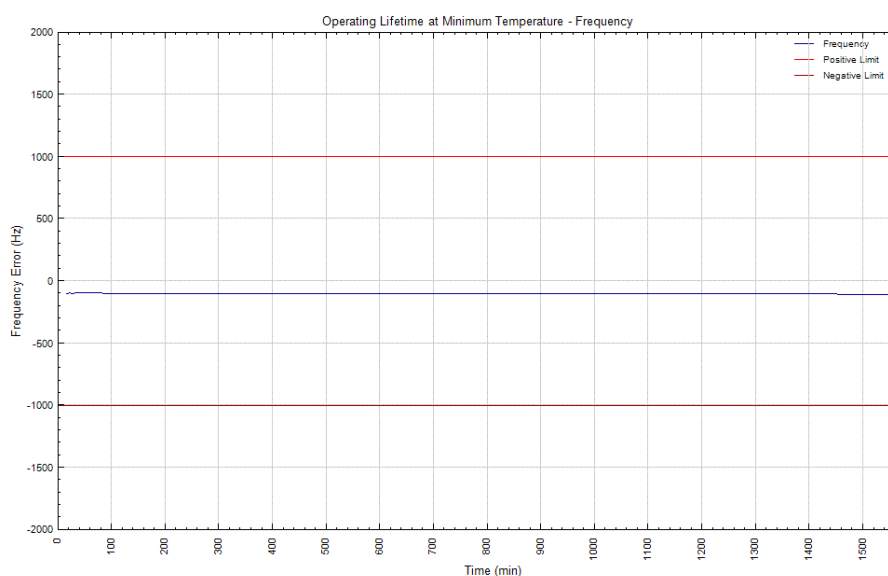



Short Term Stability

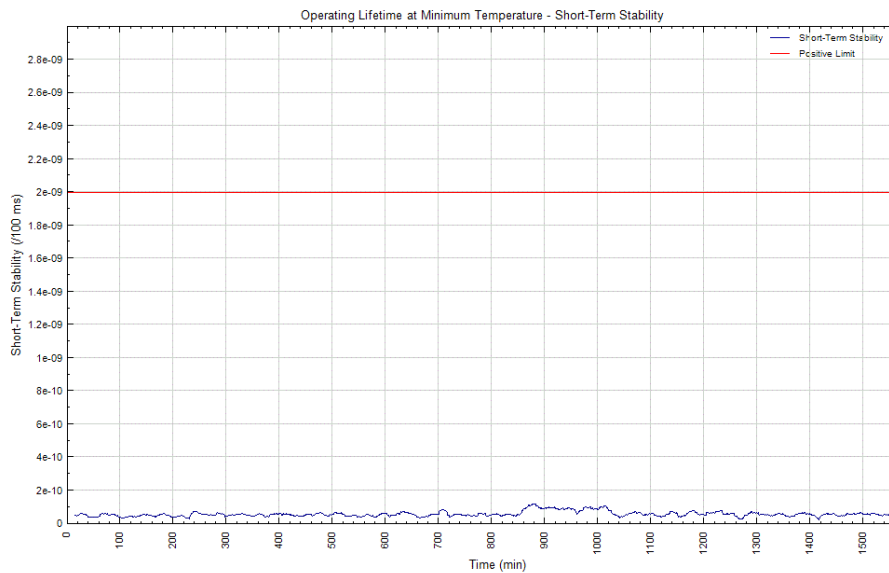

Medium Term Stability, Mean Slope

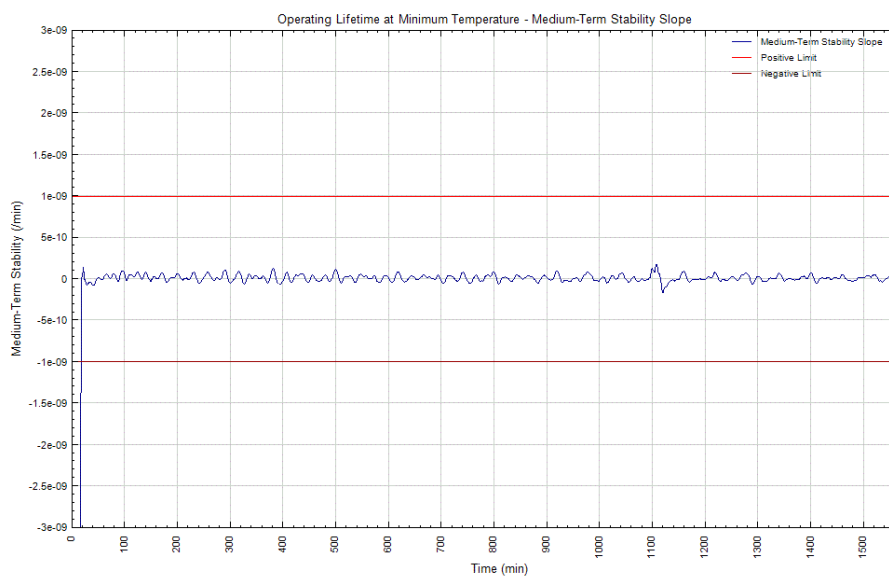



Medium Term Stability, Residual Frequency Variation

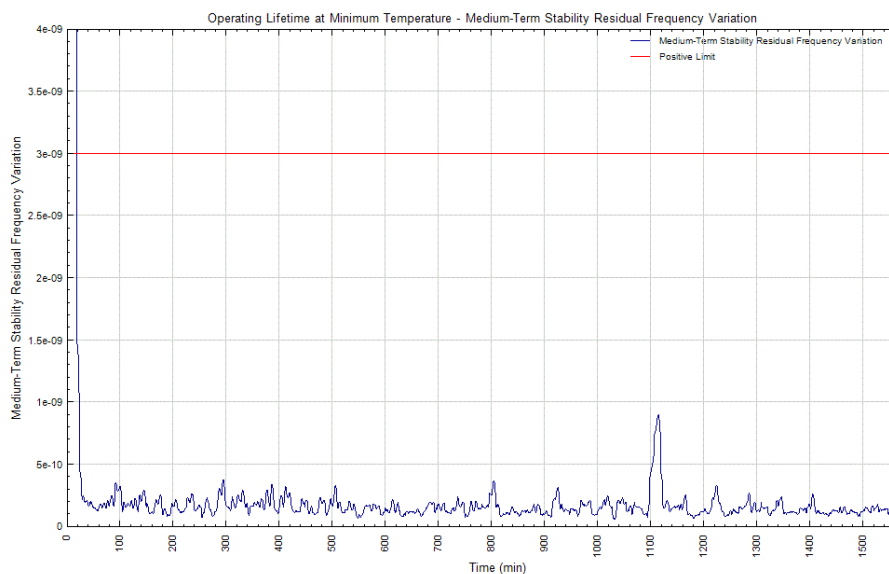

Output Power

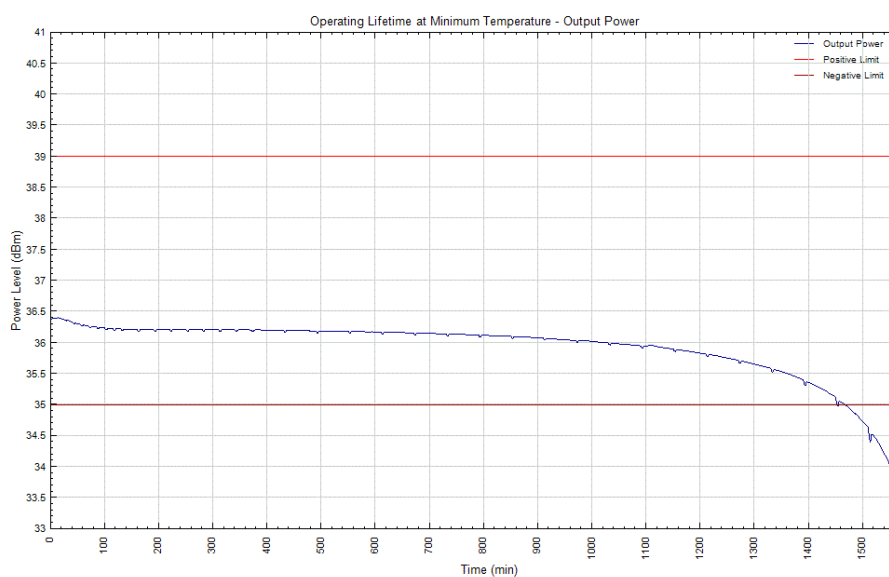



Product Service

Digital Message

Message	FFFE2F8C9EF9C0637FDF83D15B783E0F66C		
Hex ID	193DF380C6FFBFF		
Position	None - Default Values		
Parameter	Bit	Data Bits	Decoded Value
Bit synchronization	1-15	1111111111111111	1111111111111111
Frame synchronization	16-24	000101111	000101111
Format Flag	25	1	1
Protocol Flag	26	0	0
Country Code	27-36	0011001001	Albania (Republic of)
Protocol Code	37-40	1110	Standard Test Location Protocol
Undefined	41-64	111110011100000001100011	111110011100000001100011
N/S	65	0	Default
Latitude Degrees	66-72	1111111	Default
Latitude Minutes	73-74	11	Default
E/W	75	0	Default
Longitude Degrees	76-83	11111111	Default
Longitude Minutes	84-85	11	Default
BCH Code (21 Bit)	86-106	000001111010001010110	000001111010001010110
Calculated BCH Code (21 Bit)	-	000001111010001010110	000001111010001010110
Supplementary Data Fixed	107-110	1101	1101
Encoded Position Data Source	111	1	Internal
121.5 MHz Homing	112	1	Yes
Delta Latitude +/-	113	1	Default
Delta Latitude Minutes	114-118	00000	Default
Delta Latitude Seconds	119-122	1111	Default
Delta Longitude +/-	123	1	Default
Delta Longitude Minutes	124-128	00000	Default
Delta Longitude Seconds	129-132	1111	Default
BCH Code (12 Bit)	133-144	011001101100	011001101100
Calculated BCH Code (12 Bit)	-	011001101100	011001101100



Product Service

Test Data (0 min - 30 min)

#	Output Power (dBm)	Nominal Frequency (Hz)	Short Term Stability (/100 ms)	Medium Term Stability – Slope (/min)	Medium Term Stability – Residual Frequency Variation (no units)	Time (h)
1	36.36	-	-	-	-	0.000
2	36.37	-	-	-	-	0.014
3	36.38	-	-	-	-	0.029
4	36.39	-	-	-	-	0.042
5	36.39	-	-	-	-	0.056
6	36.39	-	-	-	-	0.070
7	36.39	-	-	-	-	0.085
8	36.39	-	-	-	-	0.099
9	36.39	-	-	-	-	0.113
10	36.39	-	-	-	-	0.127
11	36.39	-	-	-	-	0.141
12	36.39	-	-	-	-	0.155
13	36.4	-	-	-	-	0.169
14	36.4	-	-	-	-	0.182
15	36.4	-	-	-	-	0.196
16	36.4	-	-	-	-	0.209
17	36.4	-	-	-	-	0.223
18	36.4	406.0311	5.03E-11	-6.01E-09	2.17E-08	0.236
19	36.4	406.0311	5.00E-11	-4.54E-09	2.01E-08	0.250
20	36.4	406.0311	4.98E-11	-2.99E-09	1.66E-08	0.264
21	36.4	406.0311	4.91E-11	-1.52E-09	1.10E-08	0.278
22	36.39	406.0311	4.48E-11	-4.51E-10	4.83E-09	0.292
23	36.39	406.0311	4.98E-11	1.79E-11	1.47E-09	0.306
24	36.39	406.0311	5.12E-11	5.10E-11	1.43E-09	0.320
25	36.38	406.0311	4.91E-11	7.14E-11	1.39E-09	0.335
26	36.38	406.0311	5.28E-11	1.01E-10	1.32E-09	0.349
27	36.38	406.0311	5.22E-11	1.40E-10	1.18E-09	0.363
28	36.37	406.0311	5.33E-11	1.34E-11	4.55E-10	0.377
29	36.37	406.0311	6.04E-11	-1.35E-11	4.42E-10	0.391
30	36.37	406.0311	6.25E-11	-7.43E-12	4.29E-10	0.404
31	36.37	406.0311	6.26E-11	-1.75E-11	4.28E-10	0.419
32	36.36	406.0311	6.23E-11	-4.31E-11	3.67E-10	0.432
33	36.36	406.0311	6.15E-11	-6.39E-11	2.71E-10	0.446
34	36.36	406.0311	6.09E-11	-7.36E-11	2.21E-10	0.459
35	36.35	406.0311	5.93E-11	-7.52E-11	2.13E-10	0.473
36	36.35	406.0311	5.94E-11	-6.60E-11	2.47E-10	0.486
37	36.37	406.0311	5.79E-11	-5.62E-11	2.49E-10	0.500

Results outside of the specification are marked in red text.



Product Service

121MHz Homing Transmitter - Duty Cycle (Start of Test)

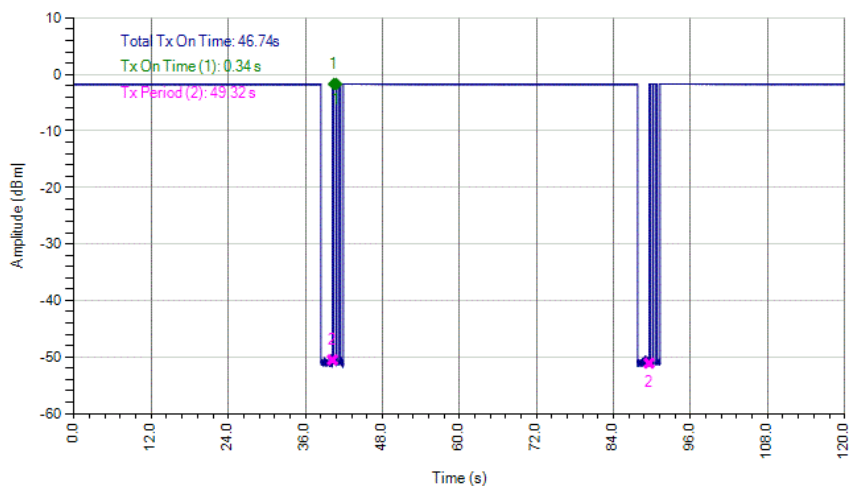

$$\text{Duty Cycle} = 46.74 / 49.32 = 94.7\%$$

121MHz Homing Transmitter - Duty Cycle (End of Test)

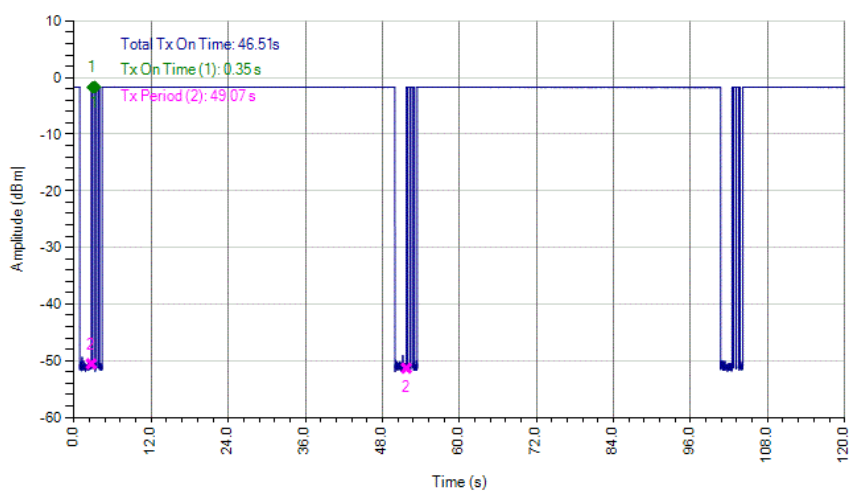

$$\text{Duty Cycle} = 46.51 / 49.07 = 94.7\%$$



Product Service

121MHz Homing Transmitter Power

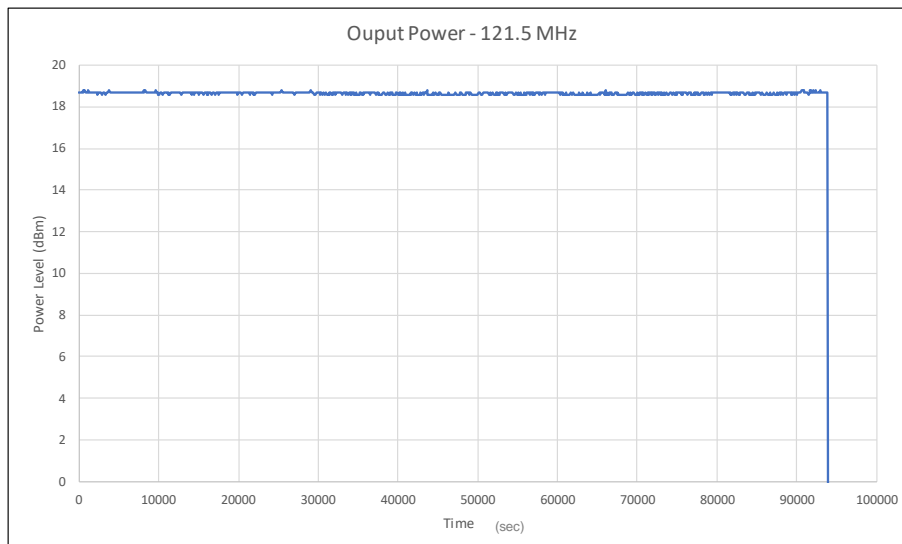

121MHz Homing Transmitter Frequency

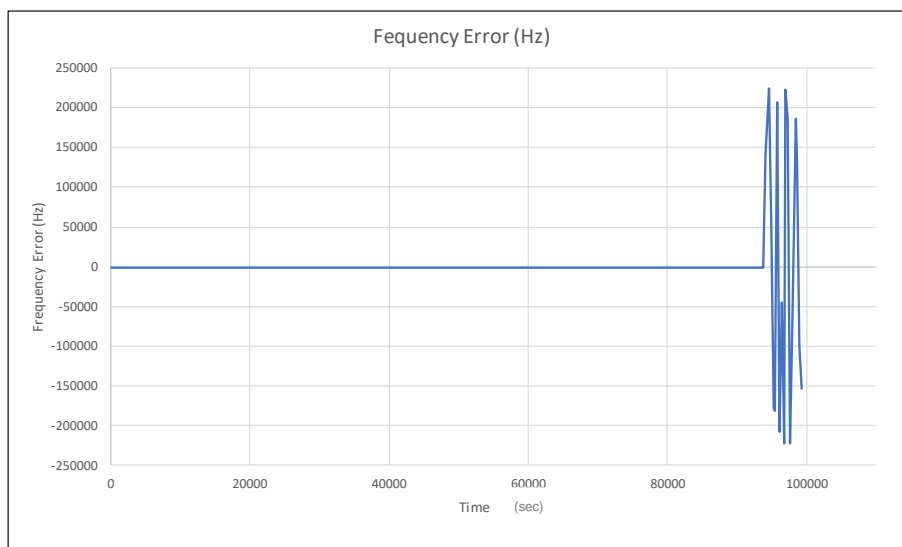



Operating Current Measurements and Analysis

System Configurations and Operating Modes

System Configuration →	A, No Ancillaries
Operational Mode ↓	
1, Standby	
2, ON at EUT switch (GPS search)	
3, ON at EUT (GPS Sleep)	
4, On at EUT switch (A2 +A3)	
5, Self-test	
6, GNSS Self-test (Timeout)	
7, GNSS Self-test (Burst)	
8, On at EUT + Strobe Morse Code	
9, TEST button held (continuous)	

SCOMM Results as per C/S T.007 Table F-E.1:

Beacon Operating Modes	Mode: Manually selectable or Automatic	Measurement interval, sec	Average Current, mA	Peak Current, mA
A1	A	599.9	0.00001455	0.00001785
A2	M	1798	57.19	1336
A3	M	297.4	47.69	1324
A4	M	2096	55.84	1336
A5	M	20.31	50.97	1309
A6	M	311.1	18.17	21.63
A7	M	51.43	27.84	1307
A8	M	12.73	52.23	64.89
A9	M	75.6	17.89	21.63

The sampling interval was a nominal 80 ms for all measurements.



Worst Case System Configurations / Operating Modes

“Lifetime in service” drains (highest average current):

- Standby: A1
- Self-test: A5
- GNSS Self-test (Timeout): A6
- GNSS Self-test (Burst): A7

Note: “Worst case” GNSS Self-test is a test which almost times out but acquires at the last possible moment; to account for this, the “burst” discharge was added to the “timeout” discharge.

Operating mode during the Lifetime test (highest average current)

A4 – On at EUT switch (A2 +A3) (subject to GNSS receiver duty cycle)

Conditions during Lifetime test

GNSS Signals: None applied

Current Measurement Plots

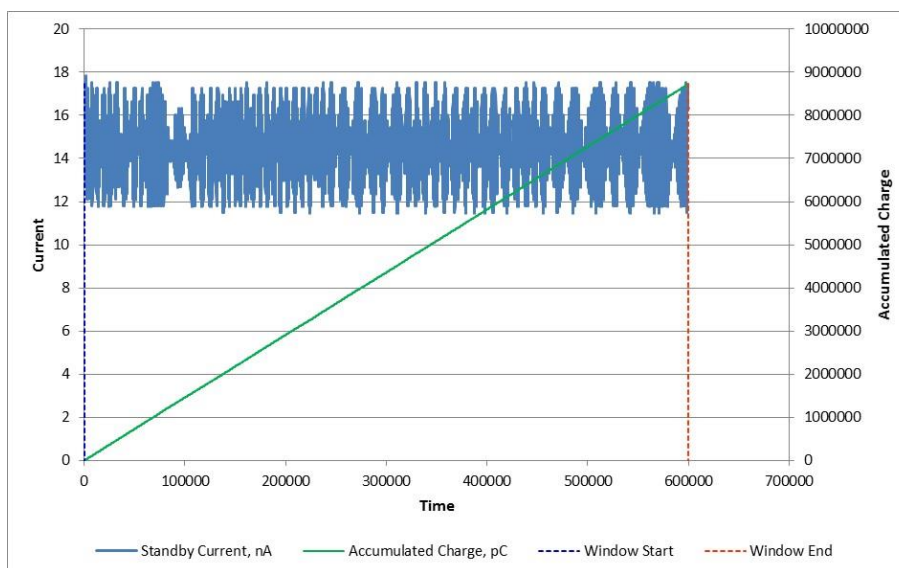

Standby: A1

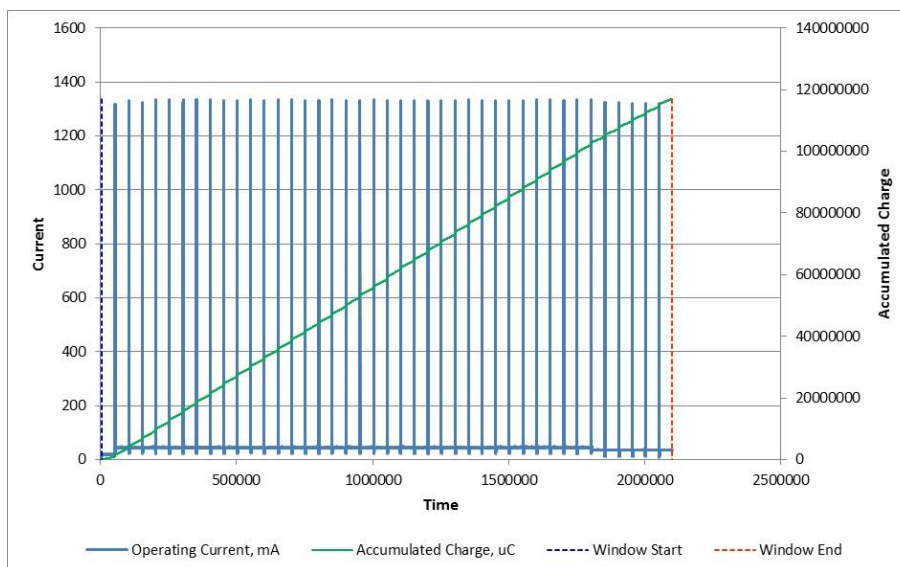

On at EUT Switch A4

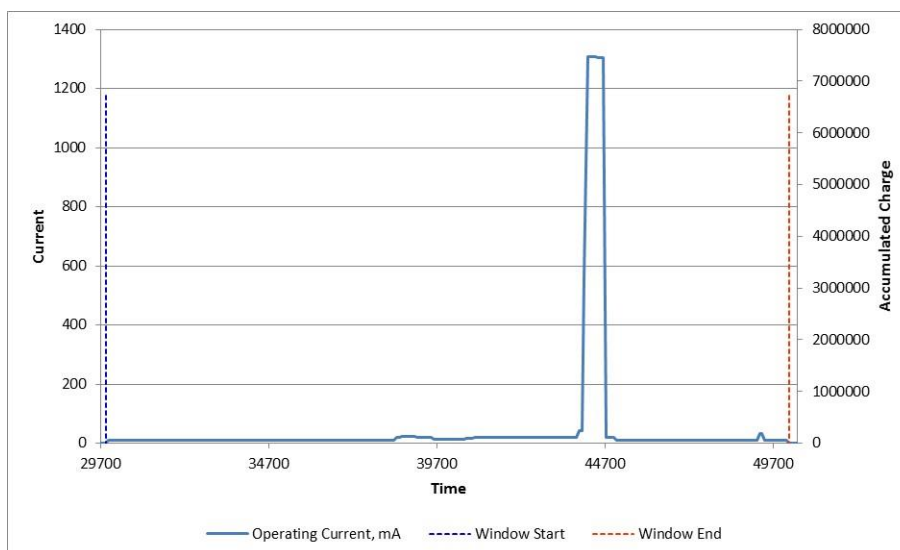

Self-test: A5

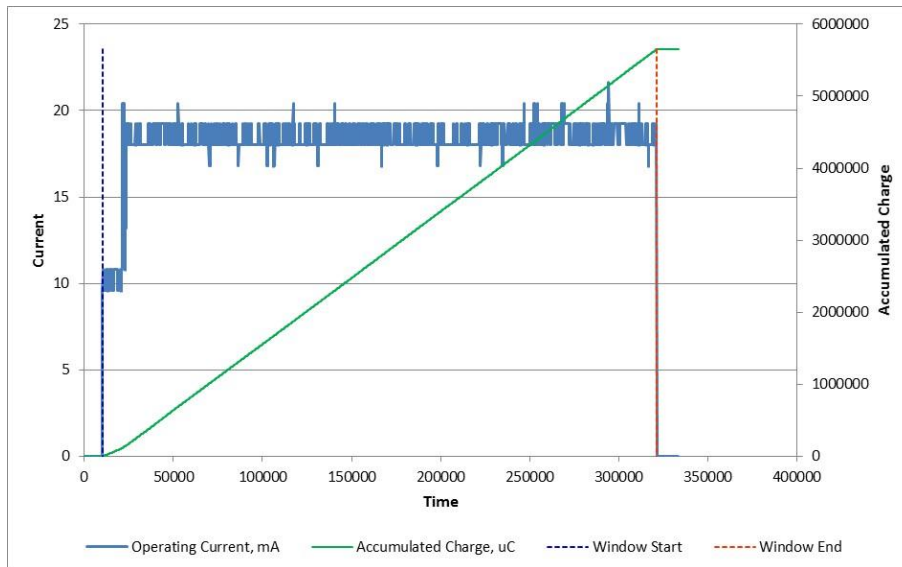

GNSS Self-test (Timeout): A6

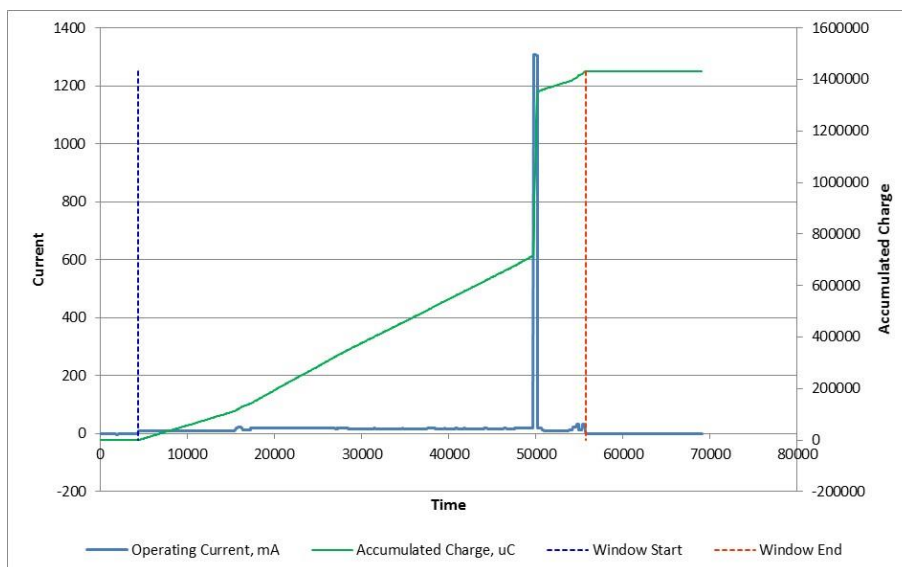

GNSS Self-test (Acquire): A7



Product Service

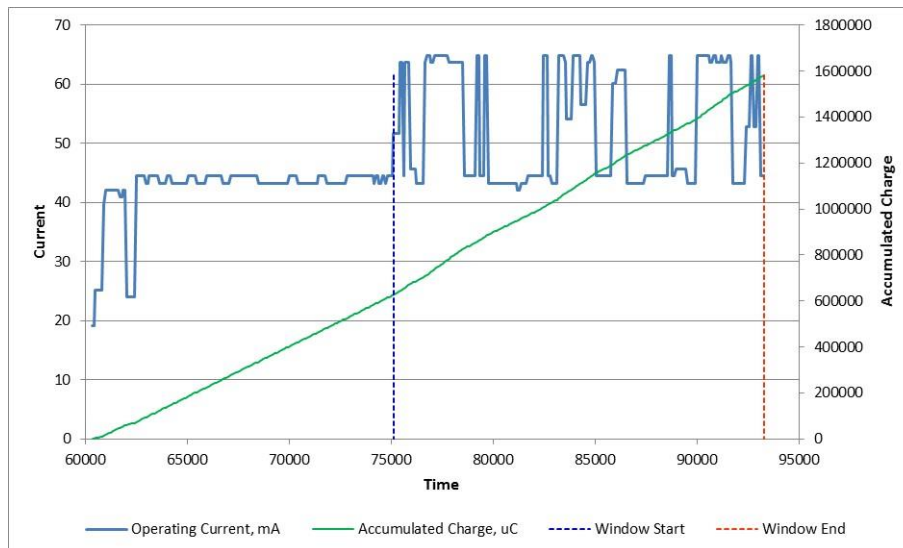

Strobe Light Morse Code: A8

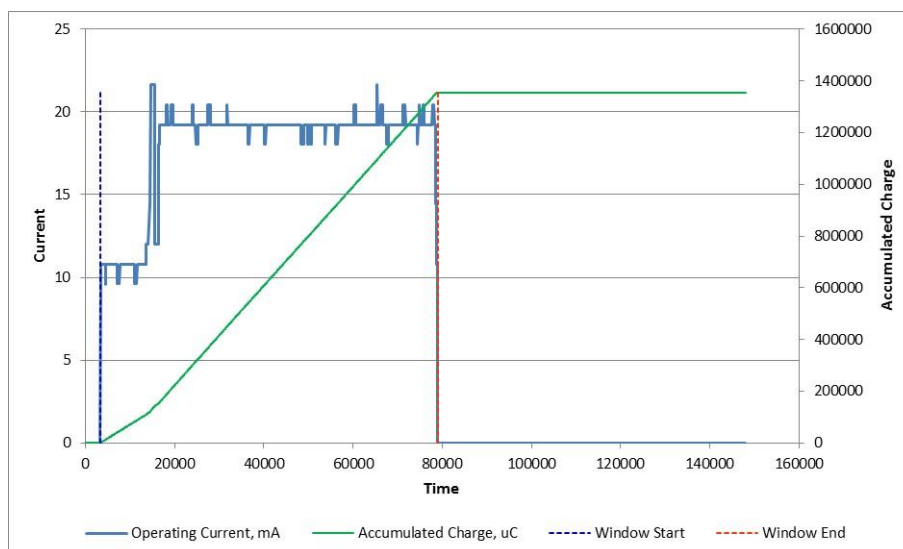

Test Switch held in ON position (demonstrates return to zero current): A9



Battery Conditioning Calculations

As per C/S T.007 Table F-E.2:

Characteristic	Designation	Units	Value	Comments
Beacon manufacturers declared maximum allowed cell shelf-life (from date of cell manufacture to date of battery pack installation in the beacon)	T _{CS} or TCS	Years	1	
Declared beacon battery replacement period (from date of installation in the beacon to expiry date marked on the beacon)	T _{BR} or TBR	Years	6	
Battery pack electrical configuration	-	-		
Cell model and cell chemistry	-	-	Lithium Manganese Dioxide	
Nominal cell capacity	-	Ah	1.5	
Nominal battery pack capacity	C _{BN}	Ah	1.5	
Annual battery cell capacity loss (self-discharge) due to aging, as specified by cell manufacturer at ambient temperature	L _{SDC}	%	1	
Calculated battery pack capacity loss due to self-discharge: $L_{CBN} = C_{BN} - [C_{BN} * (1 - L_{SDC} / 100)^{TBR+TCS}]$	L _{CBN}	Ah	0.1019	
Number of self-tests per year	N _{ST}	-	10	Declared Value
Average battery current during a self-test	I _{ST}	mA	50.97	
Maximum duration of a self-test	T _{ST}	s	20.3	Measured Value
Calculated battery pack capacity loss due to self-tests during battery replacement period: $L_{ST} = I_{ST} * T_{ST} * T_{BR} * (N_{ST} / 3600)$	L _{ST}	mAh	17.24	
Maximum Number of GNSS self-tests between battery replacements	N _{GST}	-	10	Declared Value
Average battery current during a GNSS self-test of maximum duration	I _{GST}	mA	19.53	Calculated value (Burst + Timeout)
Maximum duration of a GNSS self-test	T _{GST}	s	362.4	Calculated value (Burst + Timeout)
Calculated battery pack capacity loss due to GNSS self-tests during battery replacement period: $L_{GST} = I_{GST} * T_{GST} * (N_{GST} / 3600)$	L _{GST}	mAh	19.6602	
Average stand-by battery pack current	I _{SB}	mA	0.00001455	Measured Value
Other Capacity Losses	L _{OTH}	mAh	1.29	See Comment below
Battery pack capacity loss due to constant operation of circuitry prior to beacon activation: $L_{ISB} = I_{SB} * T_{BR} * 8760$	L _{ISB}	mAh	0.7647	
Calculated value of the battery pack pre-test discharge $L_{CDC} = L_{CBN} + 1.65((L_{ST} + L_{GST} + L_{ISB})/1000) + (L_{OTH}/1000)$	L _{CDC}	Ah	0.1653	



Battery Discharge Calculations

Characteristic	Designation	Units	Value	Comments
Method of discharge	-	-	Constant Current	Fresh Battery discharged across a 190 Ohm resistor
Discharge current	I_D	mA	60	
Discharge duration, $T_D = L_{CDC} / (I_D * 1000)$	T_D	h	2.76	

Comment: Once activated, the user may press the 'On' button to activate a 'Morse Code SOS' strobe light indicator. After activation, each time the 'On' button is pressed the strobe will flash a 'SOS' sequence four times in succession, before returning to the normal activation flash rate. This function can be used a maximum of 30 times to save battery capacity. Measurements indicate that each activation of the 'SOS' strobe function consumes an additional 0.043mAh. Therefore, 30 activations would consume 1.29mAh.

Battery Conditioning Results

A fresh battery was used for the test; it was discharged by connection to a resistive load for the pre-test discharge duration calculated as follows:

$$\begin{aligned} \text{Pre-test discharge (L}_{CDC}\text{) [mAh]} &= 165.3 \\ \text{Constant current [mA]} &= 60.0 \\ \text{Pre-test discharge duration [h]} &= \frac{165.3}{60.0} \\ &= 2.76 \end{aligned}$$

The actual discharge duration was 2.92 h resulting in a discharge of 175.3 mAh; an over-test of 6 %.

Summary

The EUT complies with clause A.2.3 of Cospas-Sarsat T.007.



Product Service

2.5 SATELLITE QUALITATIVE TESTS

2.5.1 Specification

Cospas-Sarsat T.007, Clause A.2.5

2.5.2 Equipment Under Test and Modification State

Fastfind PLB 220 - Z423 S/N: #18 - Modification State 1 (configuration 8 only)

2.5.3 Date of Test

27 September 2018 – 28 September 2018

2.5.4 Test Equipment Used

The major items of test equipment used for the above tests are identified in Section 3.1.

2.5.5 Environmental Conditions

Ambient Temperature 14.2 – 25.4°C
Relative Humidity 46.9 – 79.9%



2.5.6 Test Results

Configuration 8 (Modification State 1)

Test Start: 15:00 27/9/18
 Test End: 09:30 28/9/18
 15 Hex ID: 193DF380C6FFBFF

Actual location of the test beacon: 50.81430585
 (Daedalus Airfield, Lee-on-the-Solent, Central) -1.20175988

Satellite ID	Satellite Pass Number	15 Hex ID Provided by LUT	Doppler Latitude	Doppler Longitude	Mean Rx Power (dBm)	TCA	CTA (deg)	Location Error (km)
S11	61958	193DF 380C6 FFBFF	50.81723	-1.18747	-126.27	22:38:28	-18.690	1.052
S11	61957	193DF 380C6 FFBFF	50.65304	-0.45013	-116.90	20:57:16	-3.154	55.819
S13	31273	193DF 380C6 FFBFF	50.81877	-1.18779	-129.85	21:59:22	-11.006	1.096
S13	31272	193DF 380C6 FFBFF	50.81890	-1.20790	-127.62	20:18:58	4.610	0.667
S10	68827	193DF 380C6 FFBFF	50.83101	-1.19198	-121.21	20:04:22	-5.878	1.976
S11	61956	193DF 380C6 FFBFF	50.82164	-1.21445	-125.85	19:17:41	12.055	1.207
S7	5964	193DF 380C6 FFBFF	50.82730	-1.19531	-124.72	19:02:04	-9.024	1.510
S13	31271	193DF 380C6 FFBFF	50.82121	-1.21675	-131.97	18:39:59	18.145	1.302
S10	68826	193DF 380C6 FFBFF	50.82781	-1.21793	-127.73	18:23:51	9.302	1.880
S12	49665	193DF 380C6 FFBFF	50.81916	-1.19926	-127.82	17:37:42	-18.980	0.564
S7	5963	193DF 380C6 FFBFF	50.82637	-1.21724	-125.42	17:22:10	6.382	1.724
S12	49664	193DF 380C6 FFBFF	50.82028	-1.20009	-125.93	15:55:58	-2.932	0.671
S7	5962	193DF 380C6 FFBFF	50.81233	-1.21231	-128.19	15:43:38	19.487	0.775
S10	68834	193DF 380C6 FFBFF	50.79138	-1.27637	-125.51	08:21:00	-5.673	5.829
S12	49673	193DF 380C6 FFBFF	50.80849	-1.20950	-126.76	07:32:39	19.824	0.848
S7	5971	193DF 380C6 FFBFF	50.80620	-1.21756	-125.27	07:11:44	-3.030	1.432
S12	49672	193DF 380C6 FFBFF	50.81413	-1.20693	-125.83	05:53:18	6.821	0.365
S7	5970	193DF 380C6 FFBFF	50.79854	-1.20560	-131.86	05:30:56	-18.936	1.776
S12	49671	193DF 380C6 FFBFF	50.81035	-1.20989	-125.61	04:12:32	-8.635	0.724

Location Errors greater than 5 km are marked in red text.

$$\begin{aligned}
 \text{Ratio of Successful Solutions} &= \frac{\text{number of Doppler solutions within 5 km with } 1^\circ < \text{CTA} < 21^\circ}{\text{number of satellite passes over test duration with } 1^\circ < \text{CTA} < 21^\circ} \\
 &= \frac{17}{19} \\
 &= 89.5\%
 \end{aligned}$$

Summary

The EUT complies with clause A.2.5 of Cospas-Sarsat T.007.



Product Service

2.6 BEACON ANTENNA TEST (EIRP RE-CALCULATION ONLY)

2.6.1 Specification

Cospas-Sarsat T.007, Clause A.2.6

2.6.2 Equipment Under Test and Modification State

Fastfind 220 S/N: #18 - Modification State 0

2.6.3 Date of Test

25 April 2018

2.6.4 Test Equipment Used

The major items of test equipment used for the above tests are identified in Section 3.1.

2.6.5 Environmental Conditions

Ambient Temperature 17.1 – 19.2°C
Relative Humidity 78.9 – 91.4%



2.6.6 Test Results

Configuration 3

Azimuth Angle (Degrees)	Elevation Angle (degrees)									
	10		20		30		40		50	
	EIRP dBm	Ant dBi	EIRP dBm	Ant dBi	EIRP dBm	Ant dBi	EIRP dBm	Ant dBi	EIRP dBm	Ant dBi
0	39.1	1.9	40.9	3.7	42.8	5.6	38.0	0.7	34.6	-2.7
30	38.9	1.7	40.7	3.4	42.7	5.5	37.8	0.5	34.6	-2.7
60	38.9	1.6	40.8	3.6	42.7	5.5	37.7	0.5	34.9	-2.4
90	38.9	1.7	40.9	3.6	42.8	5.6	37.7	0.4	34.8	-2.5
120	38.9	1.6	41.1	3.8	42.9	5.7	37.6	0.3	34.4	-2.9
150	38.8	1.5	41.0	3.8	42.9	5.7	37.5	0.3	34.3	-2.9
180	38.8	1.5	41.2	3.9	42.9	5.7	37.5	0.3	34.5	-2.8
210	38.8	1.5	41.2	4.0	42.7	5.5	37.4	0.1	34.1	-3.1
240	39.0	1.7	41.3	4.0	42.8	5.6	37.4	0.2	34.4	-2.9
270	39.1	1.8	41.3	4.1	42.9	5.7	37.5	0.3	34.4	-2.8
300	38.9	1.6	41.2	4.0	42.9	5.7	37.8	0.6	34.5	-2.8
330	39.0	1.8	41.1	3.9	42.8	5.6	37.6	0.4	34.6	-2.6

Azimuth Angle (Degrees)	Elevation Angle (degrees)									
	10		20		30		40		50	
	Vv	Vh	Vv	Vh	Vv	Vh	Vv	Vh	Vv	Vh
0	111.2	90.6	112.6	92.5	113.8	91.0	107.8	92.7	103.0	75.9
30	111.0	92.3	112.4	90.3	113.7	92.5	107.6	92.4	103.0	73.8
60	111.0	88.0	112.5	92.5	113.7	93.2	107.5	93.3	103.3	70.2
90	111.0	90.4	112.6	89.0	113.8	93.4	107.5	92.1	103.2	75.7
120	111.0	89.3	112.8	89.5	113.9	92.8	107.4	91.8	102.8	81.1
150	110.9	87.8	112.7	91.4	113.9	92.5	107.4	90.4	102.7	83.5
180	110.9	88.2	112.9	89.2	113.9	91.9	107.4	89.8	102.8	85.1
210	110.9	88.8	112.9	92.5	113.7	92.4	107.2	91.1	102.5	83.7
240	111.1	88.6	113.0	91.1	113.8	92.1	107.3	88.5	102.7	86.7
270	111.2	89.9	113.0	92.7	113.9	91.2	107.4	89.6	102.8	84.5
300	111.0	89.8	112.9	92.0	113.9	91.9	107.7	90.5	102.9	79.5
330	111.1	90.3	112.8	91.7	113.8	92.3	107.5	90.5	103.0	82.1
Min (Vv-Vh)	18.7		20.0		20.5		14.2		16.1	

$$EIRP_{LOSS} = P_{t_{ambient}} - P_{t_{EOL}} = 37.26 - 35.17 = 2.09 \text{ dB}$$

$$EIRP_{maxEOL} = \text{Max}[EIRP_{max}, (EIRP_{max} - EIRP_{LOSS})] = \text{Max}[42.9, 40.8] = 42.9 \text{ dBm}$$

$$EIRP_{minEOL} = \text{Min}[EIRP_{min}, (EIRP_{min} - EIRP_{LOSS})] = \text{Min}[34.1, 32.0] = 32.0 \text{ dBm}$$



Configuration 4

Azimuth Angle (Degrees)	Elevation Angle (degrees)									
	10		20		30		40		50	
	EIRP dBm	Ant dBi	EIRP dBm	Ant dBi	EIRP dBm	Ant dBi	EIRP dBm	Ant dBi	EIRP dBm	Ant dBi
0	34.9	-2.3	38.1	0.8	37.1	-0.1	35.0	-2.2	31.4	-5.9
90	35.3	-1.9	38.9	1.6	38.3	1.1	36.5	-0.8	34.3	-2.9
180	35.8	-1.5	39.4	2.1	39.4	2.1	38.2	0.9	37.1	-0.2
270	35.8	-1.5	39.1	1.8	38.6	1.3	37.3	0.1	35.6	-1.6

$$EIRP_{LOSS} = P_{t_{ambient}} - P_{t_{EOL}} = 37.26 - 35.17 = 2.09 \text{ dB}$$

$$EIRP_{maxEOL} = \text{Max}[EIRP_{max}, (EIRP_{max} - EIRP_{LOSS})] = \text{Max}[39.4, 37.3] = 39.4\text{dBm}$$

$$EIRP_{minEOL} = \text{Min}[EIRP_{min}, (EIRP_{min} - EIRP_{LOSS})] = \text{Min}[34.3, 32.2] = 32.2\text{dBm}$$

The antenna characteristics data has been taken from 75942209 Report 1, but with the $P_{t_{ambient}}$ and $P_{t_{EOL}}$ from the MS1 testing as reported in the present document.



Product Service

2.7 NAVIGATION SYSTEM TEST

2.7.1 Specification

Cospas-Sarsat T.007, Clause A.2.7

2.7.2 Equipment Under Test and Modification State

Fastfind PLB 220 - Z423 S/N: #10 - Modification State 1 (Standard Location Protocol only)
Fastfind PLB 220 - Z423 S/N: #18 - Modification State 1 (A.3.8.2 only)

2.7.3 Date of Test

12 October 2018

2.7.4 Test Equipment Used

The major items of test equipment used for the above tests are identified in Section 3.1.

2.7.5 Environmental Conditions

Ambient Temperature 10.1 - 23.8°C
Relative Humidity 35.5 - 100.0%



2.7.6 Test Results

Standard Protocol

Position Data Default Values (C/S T.007 A.3.8.1):

No position data was provided for > 4 hours before the test started. The beacon was activated and operated for 30 minutes without providing data. Message content was checked for all bursts during this period.

36 Hex Message	Message Count
FFFE2F8C9EF9C0637FDFF83D15B783E0F66C	36

Position Acquisition Time and Position Accuracy (C/S T.007 A.3.8.2)

Locations:

A.3.8.2.1:	50° 52.1423' N	1° 14.6799' W	①
A.3.8.2.2:	50° 48.8584' N	1° 12.1056' W	①

The appropriate position was applied, the EUT activated and time to first message containing valid position data timed.

Configuration as per C/S T.007	C/S T.007 Section A.3.8.2.1		C/S T.007 Section A.3.8.2.2	
	Time to Acquire Position (sec)	Location Error in metres	Time to Acquire Position (sec)	Location Error in metres
Configuration 8	50	25.6	50	35.8

Positional accuracy was calculated using the Haversine Formula, The Earth's radius was taken as 6367 km.

① GPS Site Survey – Live Location

Encoded Position Data Update Interval (C/S T.007 A.3.8.3):

Location:	N 50° 48.683' W 1° 37.417' ①	
Data Acquired at	15:08:58	FFFE2F8C9EF9C06332E0311EC7778EA76951
Location:	N 51° 22.583' W 1° 49.833' ①	
Data Updated at	15:14:48	FFFE2F8C9EF9C06333603CEBD1379E64DCBA
Data Update Interval	5 min 50 s	

① Input from GPS simulator

* Position 2 applied immediately after the first received message encoded with position 1.



Encoded Position Data Update Interval (C/S T.007 A.3.8.3) – Long Test:

Locations: N 0° 00.000' E 0° 00.000' (Start location). The position changes by 20km every 4m 55s, moving in a NE direction (045 bearing). ①		
Parameter	Update interval (mm:ss)	Limit (min)
0 h to 2 h – Minimum	05:47	≥ 05:00
0 h to 2 h – Maximum	14:11	≤ 30:00
2 h to 6 h – Minimum	13:22	≥ 05:00
2 h to 6 h – Maximum	28:21	≤ 30:00
6 h to 24 h – Minimum	13:16	≥ 05:00
6 h to 24 h – Maximum	28:22	≤ 60:00
Assessment	Result	Limit
Results indicate that data changes as per C/S T.001 4.5.5.4 (Y/N)	Y	
Results indicate that data changes as per manufacturer's update scheme (Y/N)	Y	

① Input from GPS simulator

Position Clearance After Deactivation (C/S T.007 A.3.8.4)

Following the Encoded Position Data Update Interval test, the beacon was deactivated and reactivated without providing navigation data. The Digital Message output was encoded with the default position data.

Position Data Input Update Interval (C/S T.007 A.3.8.5)

EUT does not accept external position input, test is not applicable.

Last Valid Position (C/S T.007 A.3.8.6)

Location: N 51° 52.121' W 1° 14.685' ①		
Data Acquired at	09:57:07	FFFE2F8C9EF9C06332E02BC44E379C8051C4
GPS Signal Navigation Data Removed		
Data Updated at	13:56:58	FFFE2F8C9EF9C0637FDFF83D15B783E0F66C
Last Valid Position Held	239min 09s	
Return to Default Position	✓	

① GPS Site Survey – Live Location

Summary

The EUT complies with clause A.2.7 of Cospas-Sarsat T.007.



Product Service

SECTION 3

TEST EQUIPMENT USED



3.1 TEST EQUIPMENT

List of absolute measuring and other principal items of test equipment.

Test Equipment

Section 2.1, 2.2 Beacons - Constant Temperature Tests					
Power Meter	Hewlett Packard	436A	83	12	26-Sep-2019
Climatic Chamber	Heraeus Votsch	VM 04/100	85	-	O/P Mon
Signal Generator	Hewlett Packard	8644A	96	12	04-May-2019
Time Interval Analyser	Yokogawa	TA720	181	12	20-Apr-2019
Termination (50ohm)	Diamond Antenna	DL-30N	337	12	19-Dec-2018
Termination (50ohm)	Radio Spares	613-690	353	12	26-Jun-2019
Attenuator (10dB, 10W)	Weinschel	23-10-34	470	12	18-Dec-2018
Attenuator: 10dB/20W	Narda	766-10	480	12	18-Dec-2018
Power Sensor	Hewlett Packard	8481A	1338	12	31-Oct-2018
Stop Clock	R.S Components	RS328 061	2674	12	25-Jul-2019
Beacon RF Unit	TUV SUD Product Service	N/A	3066	-	TU
Bandpass Filter	Trilithic	5BE406/35-1-AA	3205	12	08-Jan-2019
Meter & T/C	R.S Components	Meter 615-8206 & Type K T/C	3612	12	25-Sep-2019
1 metre N-Type Cable	Florida Labs	NMS-235SP-39.4-NMS	4510	12	10-Jun-2019
Oscilloscope	Yokogawa	DL750	4552	12	09-Apr-2019
Bandpass Filter (1MHz)	KR Electronics	3219-SMA	4602	12	03-Sep-2019
Section 2.9 Beacons - Operating Lifetime					
Climatic Chamber	Heraeus Votsch	VMT 04/30	40	-	O/P Mon
Power Meter	Hewlett Packard	436A	83	12	26-Sep-2019
Climatic Chamber	Heraeus Votsch	VM 04/100	85	-	O/P Mon
Rubidium Frequency Standard	Quartzlock	A10-B	92	12	27-Feb-2019
Beacon RF Unit	TUV SUD Product Service	N/A	97	-	TU
Time Interval Analyser	Yokogawa	TA720	181	12	20-Apr-2019
Attenuator 10dB 10W	Weinschel	47-10-34	398	12	18-Jul-2019
Attenuator (10dB, 75W)	Bird	8308-100	469	12	19-Dec-2018
Attenuator (10dB, 10W)	Weinschel	23-10-34	470	12	18-Dec-2018
3dB/10W Attenuator	Texscan	HFP-50N	475	12	13-Apr-2019
Attenuator: 10dB/20W	Narda	766-10	480	12	18-Dec-2018
Signal Generator (100kHz to 2.6GHz)	Hewlett Packard	8663A	1063	12	23-Apr-2019
Power Sensor	Hewlett Packard	8481A	1338	12	31-Oct-2018
Spectrum Analyser	Rohde & Schwarz	FSU26	2747	12	19-Feb-2019
Hygromer	Rotronic	I-1000	2829	12	29-Nov-2018
Beacon RF Unit	TUV SUD Product Service	N/A	3066	-	TU
Attenuator (3dB, 20W)	Aeroflex / Weinschel	23-03-34	3163	12	20-Dec-2018
Bandpass Filter	Trilithic	5BE406/35-1-AA	3205	12	08-Jan-2019
Time Interval Analyser	Yokogawa	TA720 704510	3253	12	16-Nov-2018
ScopeCorder	Yokogawa	DL750 701210	3254	12	10-Nov-2018
Rubidium Frequency Standard	Symmetricom	8040C	3490	12	11-May-2019
2 metre N-Type Cable	Florida Labs	NMS-235SP-78.8-NMS	4508	12	10-Jul-2019



1 metre N-Type Cable	Florida Labs	NMS-235SP-39.4-NMS	4511	12	24-Apr-2019
Oscilloscope	Yokogawa	DL750	4552	12	09-Apr-2019
Bandpass Filter (1MHz)	KR Electronics	3219-SMA	4600	12	03-Sep-2019
Cable (18GHz)	Rosenberger	LU7-036-1000	5028	-	O/P Mon
Section 2.9 Beacons - Battery Current Measurements					
Milliohmmeter	Hewlett Packard	3478A	2758	12	06-Dec-2018
Hygromer	Rotronic	I-1000	2829	12	29-Nov-2018
8 Channel Datalogger + Terminal Board	Pico Technology Ltd	ADC-16	3287	12	08-Jan-2019
Resistor (Nominal 0.25ohm)	TUV SUD Product Service	2x RS Components 188-071 R5/100W Resistors	3343	-	TU
Section 2.11 Beacons - Satellite Qualitative Test					
Beacon Tester	WS Technologies	BT 100S	87	-	TU
Non Conductive Standoff Box	TUV SUD Product Service	-	-	4966	TU
Humidity & Temperature Meter	Radio Spares	1361C	4420	12	01-Aug-2019

Note: some tests took place over one or more days and consequently it may appear that some of the test equipment could have been outside of the valid calibration period at the time of testing. However, we confirm that all equipment held a valid and in-date calibration when used, and we hold this information on record.

TU – Traceability Unscheduled
 OP MON – Output Monitored with Calibrated Equipment



Product Service

SECTION 4

PHOTOGRAPHS

4.1 PHOTOGRAPHS OF EQUIPMENT UNDER TEST (EUT)



Modified Test Sample - 50Ohm conducted output

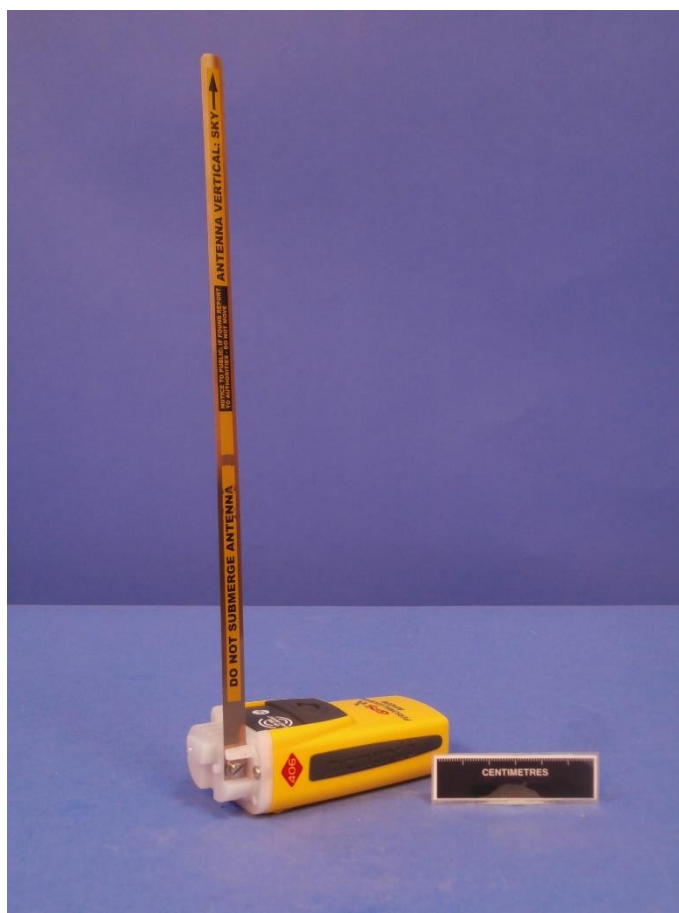

Antenna deployed



Product Service



Satellite Qualitative / A.3.8.2 - Configuration 8



Product Service

SECTION 5

ACCREDITATION, DISCLAIMERS AND COPYRIGHT



Product Service

5.1 ACCREDITATION, DISCLAIMERS AND COPYRIGHT



This report relates only to the actual item/items tested.

Our UKAS Accreditation does not cover opinions and interpretations and any expressed are outside the scope of our UKAS Accreditation.

Results of tests not covered by our UKAS Accreditation Schedule are marked NUA (Not UKAS Accredited).

This report must not be reproduced, except in its entirety, without the written permission of TÜV SÜD Product Service

© 2018 TÜV SÜD Product Service

ANNEX A

MANUFACTURER SUPPLIED DATA

Exhibit 5j-i – Protection Against Continuous Transmission

C/S T.007 Issue 5 Rev 1 February 2018 section 5.j

j. Statements and descriptions, complete with diagrams as necessary, to demonstrate that the design:

i. Provides protection against continuous transmission (see section A.3.4)

Supporting statements and description

All circuit references are to Figure 1 below.

The beacon is designed to limit any inadvertent 406.031 MHz transmission to a maximum of 2 seconds under the worst-case conditions.

The PWR_AM line provides DC bias via the resistor R45 to energise the transistor Q8-A. The transistor Q8-A then connects the gate of transistor Q2 to 0V. This switches on Q2 and supplies power to the RF power amplifier (VPA).

At the same time, the BIAS_H line supplies voltage to the gate of Q8-B via the time constant R41 and C27. If the BIAS_H line is on for longer than 2 seconds, sufficient voltage will be developed across C27 to switch Q8-B on. This will remove the DC bias from Q8-A and therefore switch off transistor Q2. This in turn removes the power supply to the RF power amplifier preventing continuous transmission.

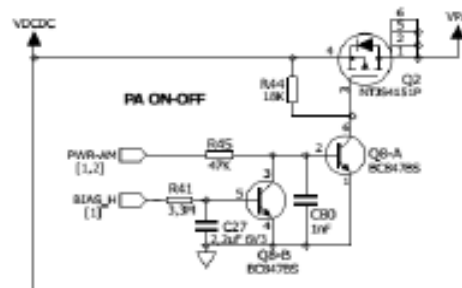

Figure 1

Erwan THOMAS
Certification and Hardware Engineer
Email: erwan.thomas@orolia.com

Exhibit 5j-ii – Self-test Characteristics

C/S T.007 Issue 5 Revision 1 February 2018 sections 5.j

j. Statements and descriptions, complete with diagrams as necessary, to demonstrate that the design:

ii. provides protection from repetitive self-test mode transmissions (see section A.3.6),

Protection against repetitive self-tests

The beacon can perform two different self-test sequences:

1. a short duration standard self-test, and
2. a long duration GNSS self-test

Self-test

The self-test sequence is initiated by pressing, holding, then releasing the TEST button after two seconds (and less than 10 seconds). The firmware monitors the duration of the TEST button presses; looking for firm, continuous requests, thus avoiding accidental self-tests. Once self-test is initiated the beacon executes a linear code function that runs just once then powers down the beacon. The RF transmissions can occur only once per self-test. It is not possible to restart the self-test function during the test sequence.

After pressing the TEST button, the white LED flash confirms that self-test has been initiated. Further flashes occur when Homer and 406 MHz test RF transmissions occur. If self-test has passed the white strobe LED flashes; three white flashes indicate a fresh battery, two white flashes indicate that 50% or more of the spare battery capacity has been used up and one white flash indicates that the battery energy is potentially insufficient to support the full 24 hours operating lifetime. If self-test fails, then the LED doesn't flash. After completing the self-test indications, the beacon powers down.

GNSS Self-test

The GNSS self-test sequence is initiated by pressing and holding the TEST button for 10 seconds until the white LED flashes. The firmware monitors the duration of the TEST button presses looking for firm, continuous requests, thus avoiding accidental GNSS self-tests. Once GNSS self-test is initiated the beacon executes a linear code function that runs just once then powers down the beacon. It is not possible to restart the GNSS self-test function during the test sequence.

After pressing the TEST button for 10 seconds a single long LED flash indicates that the limited number of GNSS self-test attempts has been attained. The beacon then does not continue the GNSS self-test and immediately powers down. The beacon limits the number of GNSS self-tests by counting each GNSS self-test occurrence and storing the value in non-volatile memory.

On successful initiation of GNSS self-test a slow flashing white LED indicates that the GNSS receiver is searching. When a position fix is acquired, a 406 MHz transmission is made containing the encoded location and white flashes indicate success; three white flashes indicate 4 or more tests remaining, two white flashes indicate that less

than 4 tests remaining, one white flash only indicates that there is no remaining test. The beacon then powers down.

If no position is acquired 300 seconds (+10 seconds of TEST button pressing) after start of GNSS searching, no transmission is made, no LED flashes and the beacon powers down.

Erwan THOMAS
Certification and Hardware Engineer
Email: erwan.thomas@orolia.com

Exhibit 5n-i – GNSS Receiver Operational Description

C/S T.007 Issue 5 Rev 1 February 2018 section 5.n

for beacons with an internal GNSS receiver, description of the GNSS receiver operation cycle and its phases, including duration and average battery current measured for each phase,

GNSS Receiver Description

Technical datasheets for the internal GNSS receiver and its antenna are included as separate exhibits:

- Exhibit 5n-ii GNSS Receiver Technical Data Sheet
- Exhibit 5n-iii GNSS Antenna Technical Data Sheet

The beacon uses a GNSS receiver type NEO-M8N from supplier uBlox. The associated antenna is a passive patch antenna type CGGP.18.2.A.02 from Taoglas.

The GNSS receiver supports simultaneous reception of GPS and Galileo.

GNSS Operation Cycle.

The paragraphs in *italics* are taken from T.001 Issue 4 Rev 2 para 4.5.5.4 internal GNSS timing requirements. The paragraphs in between describe how the beacon operation is compliant.

- *The internal navigation device within the beacon shall be activated immediately after the beacon is turned on. Once the navigation device acquires a fix it shall continue to attempt to acquire locations for a further period of at least 10 seconds and encode the location with the lowest HDOP obtained during this period into the next available beacon message.*

The GNSS receiver is activated at the same time that the beacon is turned on. Initially the GNSS receiver internal memory is cleared of time, previous location, almanac and ephemeris data via a command from the microcontroller. Then during the initial 30 minutes the GNSS receiver remains turned on irrespective of whether a fix is obtained and acquires almanac and leap seconds information. Before reporting an initial position, it delays for 20 seconds searching for lowest HDOP. The encoded location data is placed into the next 406 MHz message.

- *Between each attempt to obtain a 'fix' the navigation device may be put into a sleep mode that may retain ephemeris and / or almanac data, such that when it is subsequently woken up it warm starts.*

The GNSS receiver is commanded to cold start when the beacon is first turned on. Thereafter, it is put into a sleep mode between operation cycles and warms starts (retains ephemeris and almanac data) when woken up from sleep.

- *Subsequent valid updated location 'fixes' shall be encoded into the next available beacon message. The navigation device search/sleep timing should be determined*

by the beacon manufacturer to optimize location performance whilst saving battery capacity, subject to the following minimum requirements:

- *The internal navigation device shall make at least one attempt every 15 minutes to obtain an initial location; until an initial location is obtained or 2 hours has passed after beacon activation.*

After the initial 30-minute period, if no initial position was obtained, then until 2 hours has passed, the GNSS receiver wakes up every 15 minutes for 3 minutes 30 seconds. If a valid position were to be obtained before 3 minutes and 30 seconds, then the GNSS receiver on period is extended by 20 seconds to search for the lowest HDOP before the GNSS receiver is put into sleep mode.

In addition, if a GNSS signal is present and a valid location is available, the GNSS receiver is activated every 12 minutes for a duration of 45 seconds to facilitate opportunity for a location improvement to allow greater positional accuracy for a moving beacon.

- *After an initial location is obtained or 2 hours has passed after beacon activation without obtaining an initial location, the navigation device shall attempt location updates according to the following regime:*
- *In the first 6 hours after beacon activation the navigation device shall attempt at least one location update every 30 minutes.*

After 2 hours, if no new position was obtained, the GNSS receiver wakes for 3 minutes and 30 seconds every 30 minutes. If a valid position were to be obtained before 3 minutes and 30 seconds, then the GNSS receiver on period is extended by 20 seconds to search for the lowest HDOP before the GNSS receiver is put into sleep mode.

In addition, if a GNSS signal is present and a valid location is available, the GNSS receiver is activated every 12 minutes for a duration of 45 seconds to facilitate opportunity for a location improvement to allow greater positional accuracy for a moving beacon.

- *Between 6 hours after beacon activation and until the end of the declared operating lifetime (depending on beacon type) a location update shall be attempted at least every 60 minutes, after this location updates are not mandatory.*

After 6 hours, if no new position was obtained, the GNSS receiver wakes every 60 minutes for 3 minutes and 30 seconds. If a valid position were to be obtained before 3 minutes and 30 seconds, then the GNSS receiver on period is extended by 20 seconds to search for the lowest HDOP before the GNSS receiver is put into sleep mode.

In addition, if a GNSS signal is present and a valid location is available, the GNSS receiver is activated every 12 minutes for a duration of 45 seconds to facilitate opportunity for a location improvement to allow greater positional accuracy for a moving beacon.

GNSS Battery Current.

During the GNSS "sleep" phases described above the battery current measured averages 40.1mA (A3. Operating mode in F-E-1). During the "wake" phases described above the battery current measured is an average of 54.1mA (A2. Operating mode in F-E-1). According GNSS operation cycle description above, in case GNSS location non-available the GNSS "awakes" phases represents 9,62% of minimum operating lifetime. With GNSS location non-available the GNSS device "wake" times are longer and hence the worst-case mode is with GNSS location non-available, this expected worst-case consumption is equivalent to $0,0962 \times A2 + (1 - 0,0962) \times A3 = 41,45\text{mA}$

Erwan THOMAS
Certification and Hardware Engineer
Email: erwan.thomas@orolia.com

Exhibit 5j-iv – Location Coding Protection

C/S T.007 Issue 5 Revision 1 February 2018 section 5.j

j. Statements and descriptions, complete with diagrams as necessary, to demonstrate that the design:

- iv. for location protocol beacons, provides protection against degradation in beacon 406 MHz performance due to faulty operation or failure in operation of internal or external navigation device and against invalid position encoding into the beacon message (see section 4.5.5 of C/S T.001);*

Supporting Statements and Description

The internal navigation device is a u-blox NEO-M8N GNSS receiver. There is no interface for an external navigation device.

Software Protection

The positional data is sent from the GNSS receiver in serial NMEA format. This data is checked for validity by examining the message field quality bit and calculated HDOP (Horizontal Dilution Of Precision) figure. The quality bit is calculated by the GNSS receiver to determine the quality of the position fix and requires three or more satellites with good signal to noise ratios. The HDOP figure is calculated from the relative geometry of the satellites used to determine the position fix. The smaller the figure the better the positional accuracy. The software rejects position fixes with a HDOP figure greater than 20. A fix is only encoded in a 406 message when the GNSS receiver has been able to acquire data from 4 satellites.

These checks ensure that valid position data is encoded in the 406 MHz message.

If no valid position fix is available, the beacon will revert to transmitting default position values after 4 hours.

Hardware Protection

The serial NMEA data is input to the microcontroller. This input is connected to the GNSS receiver as a logic level signal. As the GNSS receiver is powered from the same voltage power supply as the microcontroller, it is not possible for the GNSS receiver to output a voltage from its NMEA output that can compromise the operation of the microcontroller. In addition, output ports are protected using series resistors to limit current; a fault on the NMEA line will not inhibit normal operation of the beacon.

The power state of the GNSS receiver is controlled by a separate control line connected directly between the microcontroller and GNSS receiver. This is used to power on the GNSS receiver only when a new position fix is required.

Erwan THOMAS
Certification and Hardware Engineer
Email: erwan.thomas@orolia.com

Exhibit 5j-iii

C/S T.007 Issue 5 Revision 1 February 2018 sections 5.j

j. Statements and descriptions, complete with diagrams as necessary, to demonstrate that the design:

iii. ensures that the self-test messages (except for GNSS self-test) have default values encoded in position fields, at all times and irrespective of the navigation data input.

Default location values

The self-test 406 transmission sends a message containing only default values encoded into position fields at all times and irrespective of the navigation data input.

This is achieved as follows; on successful completion of the self-tests, the self-test function calls the 406 transmission scheduling function with a dedicated parameter eTestStartTxNoLocation. This parameter is used to indicate to the message construction code that the message position fields should only contain the default position data that is contained in a permanent non-modifiable data structure and which are set to the values as defined in C/S T.001 Issue 4 Revision 2 February 2018 A3.2.

Erwan THOMAS
Certification and Hardware Engineer
Email: erwan.thomas@orolia.com

Exhibit 5v – Self-test indication of insufficient battery energy

C/S T.007 Issue 5 Revision 1 February 2018 section 5.v

technical information for characterisation of the self-test indication of insufficient battery energy to be provided as per Table F-E.5:

- *Minimum Duration of Continuous Operation (Cco), which is declared by the manufacturer in the type-approval application form, Annex G of document C/S T.007, as the Operating Lifetime;*
- *Full Battery Pack Capacity (CBP), which is defined as the duration in hours that a beacon with a fresh battery pack will continuously operate for in the worst-case operating mode (i.e. operating mode that draws the highest current from the battery) until it the beacon fails to meet C/S T.001 requirements;*
- *Capacity corresponding to the Pre-Operational Losses (Cpo), which is defined as the duration in hours required to deplete the fresh battery by the value corresponding to the Calculated Battery Pack Pre-Discharge (Lcpc) of the Table F-E.2 * by operating the beacon in the worst-case operating mode;*
- *Spare battery pack capacity at ambient temperature (CSP.AMB), which corresponds to the battery energy that could remain after the beacon with a pre-discharged battery has been operated in the worst-case mode at minimum temperature for the duration of the declared minimum continuous operation. CSP.AMB may be calculated as the Full Battery Pack Capacity (CBP) deducted by the sum of the Capacity of Pre-Operational Losses (Cpo) and the Minimum Duration of Continuous Operation (Cco). The value of CSP.AMB shall be declared by the beacon manufacturer or measured by the test facility; and*
- *Description of conditions and specification of criteria that shall be met to trigger the indication of Potentially Insufficient Battery Energy (PIE) during self-test*

Self-test indication of insufficient battery energy

According declaration in Annex G, the declared value of Cco is 24 hours.

For result of self-test battery indication, the following test on battery remaining capacity (Csp) is performed (assuming the beacon hasn't any failure):

- If $C_{SP} > 50\%$ of $C_{SP.AMB}$ then the self-test result in 3 flashes of white LED (no PIE indication)
- If $C_{SP} \leq 50\%$ of $C_{SP.AMB}$ then the self-test result in 2 flashes of white LED (no PIE indication)
- If there is no remaining spare capacity, the self-test only results in a single flash of white LED. That define the PIE indication; the battery must be replaced.

Table F-E.5: Indication of Insufficient Battery Energy

Parameter	Units	Declared by beacon manufacturer	Verified and evaluated by accepted test facility	Notes
Minimum duration of continuous operation (Cco)	hours	-		Cco is declared in Annex G as "Operating Lifetime". Cco is required for the test. Minimum duration of continuous operation (Cco)
Full Battery Pack Capacity (C _{BP})	hours	33h		If needed to calculate C _{SP-AMB}
Battery Pre-Operational Losses (C _{PO})	hours	3h30m		Corresponds to L _{CDC} , as defined in the Table F-E.2
Spare Battery Capacity at ambient temperature (C _{SP-AMB})	hours	5h30m		C _{SP-AMB} is required for the test, and shall be defined by testing (see Footnote 4 to section A.3.6.2.2), or by calculation, as follows: C _{SP-AMB} = C _{BP} - (C _{PO} + C _{CO})
Criteria and conditions to trigger PIE indication		Remaining capacity $\leq C_{CO}$ (As described above)	-	Description of PIE criteria and conditions to be met to trigger PIE indication. Use a separate sheet if needed
Step-1: battery pack discharge	hours	-		Battery discharge shall correspond to: C _{PO} - 30 minutes, or the value declared by the beacon manufacturer less 30 minutes
Step-1: beacon conditions (if applicable)		-		Description of conditions recreated during the Step-1 for which the PIE criteria is not met
Step-1: observations of self-test indication		-		Test facility observations of self-test indication: time, duration, type of indication
Step-2: battery pack discharge	hours	-		Total battery discharge shall correspond to: C _{PO} + C _{SP-AMB} + 30 minutes or the value declared by the beacon manufacturer plus 30 minutes
Step-2: beacon conditions (if applicable)	-	-		Description of conditions recreated during the Step-2 for which the PIE criteria is met
Step-2: observations of distinct PIE indication		-		Test facility observations of PIE indication: time, duration, type of indication

Beacon Z423
C/S pre-application Nr:PA17-10

Beacon coding software
&
Navigation system

TEST REPORT

This document is copyright © 2018 orolia group and/or its affiliates. All rights are strictly reserved. This document and any attached materials contains proprietary and confidential information and data and is the sole property of orolia group and/or its affiliates. The documents, any attached materials and/or information contained therein must not be used, disseminated, or distributed except for the agreed purpose. Unauthorized use, reproduction, or issue to any third party is not permitted without the prior written consent of the orolia group. This document is to be returned to the orolia group when the agreed purpose is fulfilled.

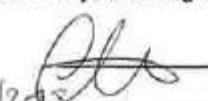
Compiled by F. Moullet: firmware engineer  Date: 12/10/2018	Approved by C.Gaudin: Senior Project manager  Date: 12/10/2018
---	---

Copyright © Orolia S.A.S. All rights reserved



**Beacon coding software
&
Navigation system**

Page: 2 of 24
Ref: DRD18046
Issue: C
Date: 27th Jul 2018

TEST REPORT

Test facility: Orolia SAS, Z.I des 5 Chemins, CS 10028, 56520, Guidel, France

Accreditations: EN 9100:2009 AS 9100C - JISQ 9100:2009, ISO 9001 : 2008

Report on: Personal Locator Beacon Z423

Prepared for: Orolia SAS

Prepared by: Florent Moullet
Firmware engineer
Tel: +33 (0)2 97 02 49 49
Email: florent.moullet@orolia.com
Website: www.orolia.com

Approved by: Chrystèle Gaudin
Senior Project Manager
Mobile: (+33) 6 98 05 42 07
Tel: (+33) 2 97 02 96 81

Email: chrystele.gaudin@orolia.com
Website: www.orolia.com

Date of Issue: 27 Jul 2018

Dates of testing:
Submitted for testing: 20th Jul 2018
Start of tests: 23rd Jul 2018
End of tests: 26th Jul 2018

Copyright © Orolia S.A.S. All rights reserved



**Beacon coding software
&
Navigation system**

Page: 3 of 24
Ref: DRD18046
Issue: C
Date: 27th Jul 2018

TEST REPORT

Date	Version	Modifications
23/03/2018	A	Initial Document
23/05/2018	B	Update results with User Location Radio Call Sign protocol
27/07/2018	C	Re-run testing with firmware A01 Add test protocols as results of testing for User, National and Standard Location protocols

Copyright © Orolia S.A.S. All rights reserved



TEST REPORT

TABLE OF CONTENTS

1	Scope	5
2	Reference Documents	5
3	Details of Test Samples	5
4	Type Approval Testing	7
5	Results	8
5.1	Test Results Summary Table.....	8
5.2	Beacon Coding Software.....	9
5.2.1	Test conditions.....	9
5.2.2	Test setup.....	10
5.2.3	Location message.....	12
5.2.4	List of protocols.....	13
5.2.5	Test Method.....	15
5.2.6	Messages as per Appendix D to Annex F.....	15
5.2.7	Table F-D.2.....	16
5.2.8	Table F-D.3.....	17
5.2.9	Test protocols.....	18
5.3	Navigation System Test.....	19
5.3.1	Test conditions.....	19
5.3.2	Test method.....	20
5.3.3	Position Data Encoding – Appendix C to Annex F: NAVIGATION SYSTEM TEST RESULTS.....	21
6	Photographs	24
7	Test Equipment Used	24
8	Other Technical Information	24
9	Technical data submitted by Beacon manufacturer	24

Copyright © Orolia S.A.S. All rights reserved



TEST REPORT

1 Scope

This test report describes the test method, equipment and set up used to demonstrate compliance of the Z423 beacon with the Cospas-Sarsat 406 MHz Distress Beacon Type Approval Standard T.007 section A.3.8.7 Position Data Encoding and section A.2.8 Beacon coding software requirements.

The tests were carried out in the manufacturer premises at Orolia SAS, Z.I des 5 Chemins, CS 10028, 56520, Guidel, France over the period from 23th Jul 2018 to the 26th Jul 2018.

2 Reference Documents

C/S T.001 Issue Specification for Cospas-Sarsat 406 MHz Distress Beacon
4 Feb 2018

C/S T.007 Issue Cospas-Sarsat 406 MHz Distress Beacon Type Approval Standard
5 Feb 2018

3 Details of Test Samples

The following test samples were used during the performance of this series of tests:

<u>EUT ID</u>	<u>Description</u>
EUT1	Z423 Serial Number 22 Part Number 91-001-2XXX Firmware Part Number 1001767 Firmware Version A01

TEST REPORT

Figure 1 - Block Diagram of Test Set Up

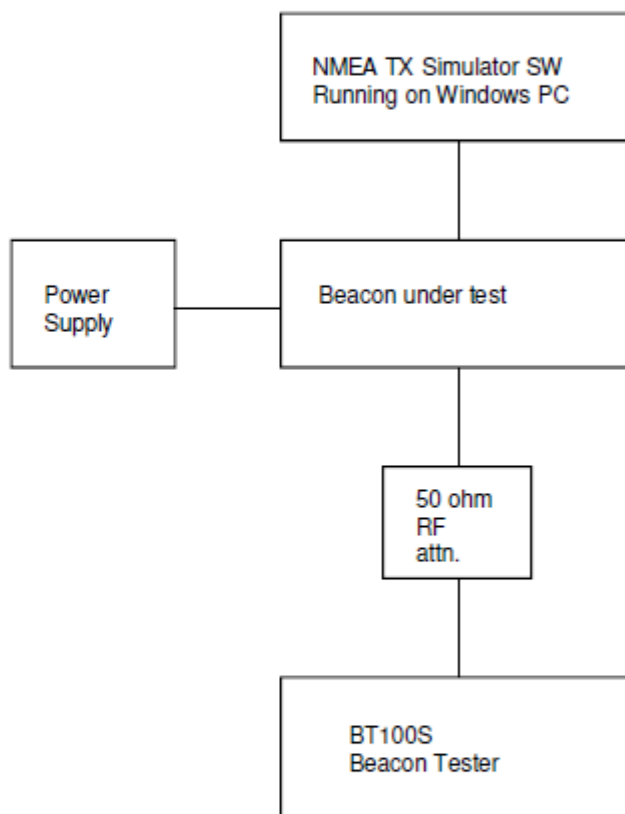

Copyright © Orolia S.A.S. All rights reserved



Beacon coding software
&
Navigation system

Page: 7 of 24
Ref: DRD18046
Issue: C
Date: 27th Jul 2018

TEST REPORT

4 Type Approval Testing

Name and Location of Beacon Test Facility: Orolia SAS, Z.I des 5 Chemins, CS 10028, 56520, Guidel, France

Date of Submission for Testing: 20th Jul 2018

Applicable C/S Standards:

Document	Issue	Revision	Date
C/S T.001	4	2	Feb-18
C/S T.007	5	1	Feb-18

I hereby confirm that the 406 MHz beacon described above has been successfully tested in accordance with the Cospas-Sarsat Type Approval Standard (C/S T.007) and complies with the Specification for Cospas-Sarsat 406 MHz Distress Beacons (C/S T.001) as demonstrated in the attached report.

There were no observed non-compliances and/or deviations from standard test procedures with the following exceptions:

1. Only tests procedures 5.8 Beacon Coding Software was performed, .5.9.7 Navigation System Test – Position Data Encoding were performed

The EUT was added 2 wires on the UART port between the GNSS module and the microcontroller to ensure that the firmware is correctly stimulated by a NMEA SW simulator running on windows during TA testing, these 2 wires ensures that the GNSS module UART signals are not active on the microcontroller.

Signed: _____

Name: _____

Position Held:
Authorised Signatory

Date: _____

Copyright © Orolia S.A.S. All rights reserved



TEST REPORT

5 Results

5.1 Test Results Summary Table

Parameters to be Measured	Range of Specification	Units	Test Results	Comments
23rd-Jul-18 – 26th-Jul-18, Z423, 22, Mod State 1 16. Beacon Coding Software - sample message provided for each coding option of the applicable coding types - sample self-test message provided for each coding option of the applicable coding types	correct	n/a	PASS	Per applicable F-D.1/F-D.2/F-D.3 Table.
	correct	n/a	PASS	Per applicable F-D.1/F-D.2/F-D.3 Table.
17. Navigation System - Position data encoding	correct	n/a	PASS	Results per Tables F-C.1, F-C.2 and F-C.3 as appropriate

TEST REPORT

5.2 Beacon Coding Software

5.2.1 Test conditions

Date of test	23 rd -Jul-2018 to 24 th -Jul-2018
Specification	C/S T.007 – section A.2.8
Beacon Model	Z423
Serial number	EUT1 (22)
EUT Mod State	MS1
EUT system configuration during the test, including antenna, external ancillary devices and modes of their operation	The EUT and test equipment was configured as shown in Figure 1. The EUT was powered from an external 9V DC power supply. The antenna port of the EUT was connected via a 50 ohm attenuator to the Beacon Tester. NMEA test data was generated using simulator SW and input directly over a serial link to the EUT.
Navigation device details (model, interface)	NMEA TX Simulator Software
Measurement Equipment, provided by beacon manufacturer, if any	None
Performed by	Florent Moullet
Verified by	Chrystèle Gaudin
Environmental conditions	Ambient laboratory temperature: +20°C to +23°C Relative air humidity: 55 to 75% RH
Deviations from standard test procedures	None
Non-compliances noticed	None

TEST REPORT

5.2.2 Test setup

Sarsat Receiver: Tester Model: BT100AVS, S/N: 2835

These tests require that NMEA data is injected into the beacon via an external simulator rather than relying on any internal GNSS module. The following procedure is adopted.

- Connect the USB to serial convertor cable to the beacon TX PCBA as follows –

USB Serial Cable	Tx PCB Test-Point	Notes
Blue (Gnd)	T0 or any suitable 0V point	
Red (Tx)	T16	Data transmit from GNSS module (Protected by R23)
Green (Rx)	NC	Do not connect this signal

- Start the NMEA Transmit Simulator program and configure it to operate with the serial port associated with the USB to serial convertor cable.

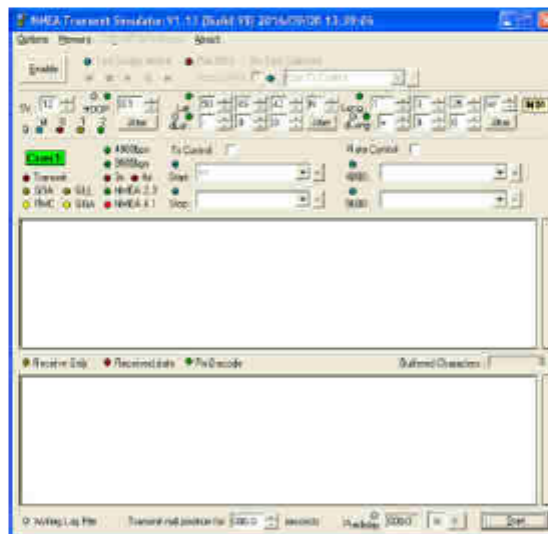

- If a valid position fix is required, ensure that the relevant values are set correctly, i.e. SV, HDOP, position etc.
- Select other options as required.

Copyright © Orolia S.A.S. All rights reserved

TEST REPORT

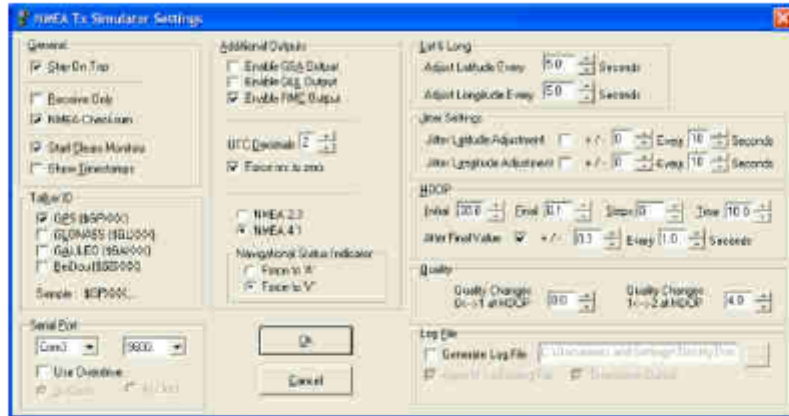

- o To simulate NMEA data, click on the 'Start' button; to simulate "no data", click the 'Quick-stop' button - the output will temporarily stop; to re-start click the 'Quick-play' button –



- o To completely stop the simulated output, click the 'Stop' button.

TEST REPORT

5.2.3 Location message

The z423 beacon is switched on from test point A to test point B. Test point A will be used as the position for GNSS test

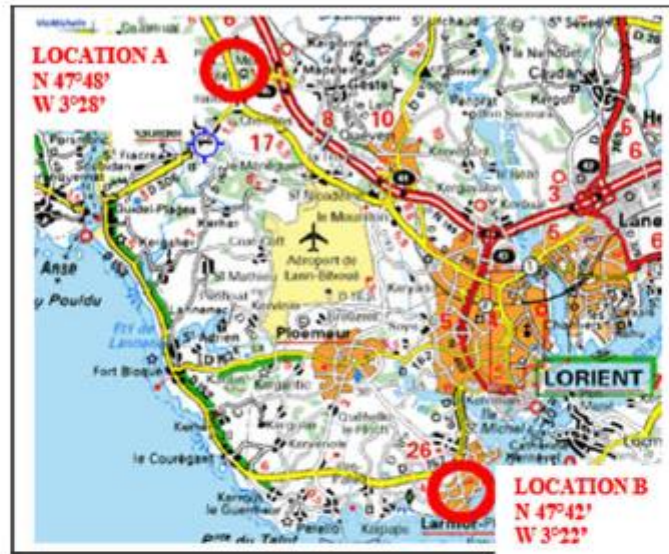

Copyright © Orolia S.A.S. All rights reserved

TEST REPORT

5.2.4 List of protocols

User location protocol

Protocol	T.007 parameters (Annex C)	Hex-id (default position) with 121 and Internal GNSS position source
PLB with Serial Number	Country code: 201 Serial number: 99 National use: default "0000000" Type Approval : 999	FFFE2FCC97A000C6007CE83E1FEFE0FF0146 15 Hex: 992F40018C00F9D
Maritime with MMSI	Country code: 201 MMSI: 999999 Beacon number: 0	FFFE2FCC94186186186689DE52AFE0FF0146 15 Hex: 992830C30C30CD1
Maritime with Radio Call sign	Country code: 201 Radio Call sign: XPA02 Beacon number: 0	FFFE2FCC9526F6F06B268F9F322FE0FF0146 15 Hex: 992A4DEDE0D64D1
EPIRB non- float free with serial number	Country code: 201 Serial number: 99	FFFE2FCC970000C600000E9F6CEFE0FF0146 15 Hex: 992E00018C00001
Radio Call sign	Country code: 201 Radio Call sign: XPA02 Beacon number: 0	FFFE2FCC9DBDBC1A55468ED9F62FE0FF0146 15 Hex: 993B7B7834AA8D1
Test	Country code: 201	FFFE2FCC9E8000C6000003441D2FE0FF0146 15 Hex: 993D00018C00000

Standard Location Protocol

Protocol	T.007 parameters (Annex C)	Hex-id (default position) with 121 and Internal GNSS position source
PLB with Serial Number	Country code: 201 Serial number: 99 Type Approval: 999	FFFE2F8C97F9C0637FDFFF11B23783E0F66C 15 Hex: 192FF380C6FFBFF
EPIRB with Serial Number	Country code: 201 Serial number: 99 Type Approval: 999	FFFE2F8C96F9C0637FDFF992EF3783E0F66C 15 Hex: 192DF380C6FFBFF
EPIRB with MMSI	Country code: 201 MMSI: 999999 Beacon number: 0	FFFE2F8C92F423F07FDFFB2BF03783E0F66C 15 Hex: 1925E847E0FFBFF
Test	Country code: 201	FFFE2F8C9EF9C0637FDFF83D15B783E0F66C 15 Hex: 193DF380C6FFBFF



Beacon coding software
&
Navigation system

Page: 14 of 24
Ref: DRD18046
Issue: C
Date: 27th Jul 2018

TEST REPORT

National Location Protocol

Protocol	T.007 parameters (Annex C)	Hex-id (default position) with 121 and Internal GNSS position source
PLB	Country code: 201 National id : 011100000100011001	FFFE2F8C9B70465FC0FF0120A9379F3C0010 15Hex: 1936E08CBF81FE0
EPIRB	Country code: 201 National id : 011100000100011001	FFFE2F8C9A70465FC0FF07A3F4379F3C0010 15 Hex: 1934E08CBF81FE0
Test	Country code: 201	FFFE2F8C9F70465FC0FF01F754779F3C0010 15 Hex: 193EE08CBF81FE0

Copyright © Orolia S.A.S. All rights reserved

TEST REPORT

5.2.5 Test Method

1. Ensure to have the beacon configured as a z423 for the required protocol test.
2. Connect the NMEA transmit simulator output to the Tx board as described in Set up. (Ensure to remove the connection for each protocol or beacon configuration programming with beacon configurator).
3. Ensure the beacon is connected to a 406 MHz beacon decoder
4. For each protocol,
 - Using Beacon Configurator, program the awaited hex-id of the beacon
 - Run Live mode, initiate the NMEA simulator with the first position:
 - Confirm that, the awaited hex-id and first position is received.
 - Stop the NMEA simulator, change the position to the second position, and restart it
 - Confirm that, the awaited hex-id and second position is received (5 mins after the first one obviously)
 - Stop the beacon and the NMEA simulator, and run short self-test mode and note the received message content
 - initiate the NMEA simulator with the first position
 - Ensure that the GNSS self-test limit is not reached. If reached, reset the counter with the beacon configurator
 - Stop the beacon and run GNSS self-test mode:
 - Confirm that, the awaited hex-id and first position is received.
5. Fill in the results for each mode: Live position A and Live position B, Self-test, GNSS self-test (using position A)

5.2.6 Messages as per Appendix D to Annex F

Hereafter the Appendix D to Annex F shows the tables F-D.2 and F-D.3 filled with the operational and self-test messages used for the validation. The table F-D.1 is not applicable.

TEST REPORT

5.2.7 Table F-D.2

Protocol	Operational Message (in hexadecimal including bit and frame synchronisation bits)		Self-Test Message (in hexadecimal including bit and frame synchronisation bits)	GNSS Self-Test Message (if applicable, in hexadecimal, including bit and frame synchronisation bits) Location "A"
	Location "A" 1	Location "B" 1		
Standard Location: PLB with Serial Number	FFFE2F8C97F9C0632FE0715566B78C020664	FFFE2F8C97F9C0632FE06B8FEFF70C270C5D	FFFED08C97F9C0637FDFFF11B23783E0F66C	FFFED08C97F9C0632FE0715566B78C020664
EPIRB with Serial Number	FFFE2F8C96F9C0632FE077D63BB78C020664	FFFE2F8C96F9C0632FE06D0CB2F70C270C5D	FFFED08C96F9C0637FDFF902EF3783E0F66C	FFFED08C96F9C0632FE077D63BB78C020664
EPIRB with MMSI	FFFE2F8C92F423F02FE0756F24B78C020664	FFFE2F8C92F423F02FE06FB5ADF70C270C5D	FFFED08C92F423F07FDFFB2BF03783E0F66C	FFFED08C92F423F02FE0756F24B78C020664
National Location: PLB	FFFE2F8C9B70464BF10373AD2F7781000D6D	FFFE2F8C9B70464BE8035A430CB781000D6D	FFFED08C9B70465FC0FF0120A9379F3C0010	FFFED08C9B70464BF10373AD2F7781000D6D
National Location: EPIRB	FFFE2F8C9A70464BF103752E727781000D6D	FFFE2F8C9A70464BE8035C051B781000D6D	FFFED08C9A70465FC0FF07A3F4379F3C0010	FFFED08C9A70464BF103752E727781000D6D

Copyright © Orolia S.A.S. All rights reserved

TEST REPORT

5.2.8 Table F-D.3

Protocol	Operational Message (in hexadecimal including bit and frame synchronisation bits)		Self-Test Message (in hexadecimal including bit and frame synchronisation bits)	GNSS Self Test Message (if applicable, in hexadecimal, including bit and frame synchronisation bits) Location "A"
	Location "A" 1	Location "B" 1		
PLB with Serial Number	FFFE2FCC97A000C6007CE83E1FE5F9037C97	FFFE2FCC97A000C6007CE83E1FE5F7036553	FFFED0CC97A000C6007CE83E1FEFE0FF0146	FFFED0CC97A000C6007CE83E1FE5F9037C97
Maritime with MMSI	FFFE2FCC94186196186689DE52A5F9037C97	FFFE2FCC94186196186689DE52A5F7036553	FFFED0CC94186196186689DE52AFE0FF0146	FFFED0CC94186196186689DE52A5F9037C97
Maritime with Radio Call sign	FFFE2FCC9526F6F06B268F9F3225F9037C97	FFFE2FCC9526F6F06B268F9F3225F7036553	FFFED0CC9526F6F06B268F9F322FE0FF0146	FFFED0CC9526F6F06B268F9F3225F9037C97
EPIRB non-float free with serial number	FFFE2FCC970000C60000E9F6CE5F9037C97	FFFE2FCC970000C60000E9F6CE5F7036553	FFFED0CC970000C60000E9F6CEFE0FF0146	FFFED0CC970000C60000E9F6CE5F9037C97
Radio Call sign	FFFE2FC09DBDBC1A55468ED9F625F9037C97	FFFE2FC09DBDBC1A55468ED9F625F7036553	FFFED0CC9DBDBC1A55468ED9F62FE0FF0146	FFFED0CC9DBDBC1A55468ED9F625F9037C97

Copyright © Orolia S.A.S. All rights reserved



TEST REPORT

5.2.9 Test protocols

Protocol	Operational Message (in hexadecimal including bit and frame synchronisation bits)		Self-Test Message (in hexadecimal including bit and frame synchronisation bits)	GNSS Self-Test Message (if applicable, in hexadecimal, including bit and frame synchronisation bits) Location "A"
	Location "A" 1	Location "B" 1		
Standard Location: Test	FFFE2F8C9EF9C0632FE07679C1378C020664	FFFE2F8C9EF9C0632FE06CA348770C270C5D	FFFE08C9EF9C0637FDF83D15B783E0F66C	FFFE08C9EF9C0632FE07679C1378C020664
National Location: Test	FFFE2F8C9F70464BF103737AD23781000D6D	FFFE2F8C9F70464BE035A94F1F781000D6D	FFFE08C9F70465FC0FF01F754779F3C0010	FFFE08C9F70464BF103737AD23781000D6D
User Location: Test	FFFE2FCC9E8000C6000003441D25F9037C97	FFFE2FCC9E8000C6000003441D25F7036553	FFFE0CC9E8000C6000003441D2FE0FF0146	FFFE0CC9E8000C6000003441D25F9037C97

Copyright © Orolia S.A.S. All rights reserved

TEST REPORT

5.3 Navigation System Test

5.3.1 Test conditions

Date of test	24th-Jul-2018 to 26-Jul-2018
Specification	C/S T.007 – section A.3.8.7
Beacon Model	Z423
Serial number	EUT1 (22)
EUT Mod State	MS1
EUT system configuration during the test, including antenna, external ancillary devices and modes of their operation	The EUT and test equipment was configured as shown in Figure 1. The EUT was powered from an external 6V DC power supply. The antenna port of the EUT was connected via a 50 ohm attenuator to the Beacon Tester. NMEA test data was generated using simulator SW and input directly over a serial link to the EUT.
Navigation device details (model, interface)	NMEA TX Simulator Software
Measurement Equipment, provided by beacon manufacturer, if any	None
Performed by	Florent Moullet
Verified by	Chrystèle Gaudin
Environmental conditions	Ambient laboratory temperature: +20°C to +23°C Relative air humidity: 55 to 75% RH
Deviations from standard test procedures	None
Non-compliances noticed	None

TEST REPORT

5.3.2 Test method

- Connect the NMEA transmit simulator output to the TX board as described in 5.2
- Ensure the beacon is connected to a 406 Mhz beacon decoder
- User location protocol
 - Program the beacon with the following Hex-ID to set the beacon in User Location Protocol: 0xFFFE2FCC9E8000C6000003441D2FE0FF0146
 - Ensure that, for each of the following table TABLE D.1, the "User Location protocol" is decoded by the beacon decoder.
 - Then Follow the instruction for each row and first column in the TABLE D.1 from T.007 and Fill in the results in Table F-C.1 from the beacon decoder output
 - Ensure to fill the third column in Table F-C.1 by verifying that the second column results are equal to the required value or time in the last column from TABLE D.1
 - Fill in the Test Result
- Standard location protocol
 - Using Beacon Configurator, program the beacon with the following Hex-ID to set the beacon in Standard Location Protocol: 0xFFFE2F8C9EF9C0637FDF83D15B783E0F66C
 - Ensure that, for each of the following table TABLE D.2, the "Standard Location protocol" is decoded by the beacon decoder.
 - Then Follow the instruction for each row and first column in the TABLE D.2 from T.007 and Fill in the results in Table F-C.2 from the beacon decoder output
 - Ensure to fill the third column in Table F-C.2 by verifying that the second column results are equal to the required value or time in the last column from TABLE D.2
 - Fill in the Test Result
- National location protocol
 - Program the beacon with the following Hex-ID to set the beacon in National Location Protocol: 0xFFFE2F8C9F70465FC0FF01F754779F3C0010
 - Ensure that, for each of the step of the TABLE D.3, the "National Location protocol" is decoded by the beacon decoder.
 - Then Follow the instruction for each row and first column in the TABLE D.3 from T.007 and Fill in the results in Table F-C.3 from the beacon decoder output
 - Ensure to fill the third column in Table F-C.3 by verifying that the second column results are equal to the required value or time in the last column from TABLE D.3
 - Fill in the Test Result

Copyright © Orolia S.A.S. All rights reserved

TEST REPORT

5.3.3 Position Data Encoding – Appendix C to Annex F: NAVIGATION SYSTEM TEST RESULTS

**Table F-C.1 of C/S T.007 Issue 5 Feb 2018
Position Data Encoding Results User-Location Protocol**

Script Reference (See Table D.1)	Value of Encoded Location Bits Transmitted by Beacon	Confirmation that BCH Correct (V)
1	Bits 108-132 = 0FE0FF0	V
2	Bits 108 – 132 = 1001000 Number of seconds after providing navigation data that beacon transmitted the above encoded location information: 50 s	V
3	Bits 108-132 = 0000000	V
4	Bits 108-132 = 0006B3C	V
5	Bits 108-132 = 1007B3C	V
6	Bits 108-132 = 1B28590	V
7	Bits 108-132 = 1B29590	V
8	Bits 108-132 = 0B41B40	V
9	Bits 108-132 = 0B3CB40	V
10	Bits 108-132 = 14918A7	V
Self-Test Navigation Test Scripts		
11	Bits 108-132 = 0FE0FF0	V
12	Bits 108-132 = 0FE0FF0	V

Copyright © Orolia S.A.S. All rights reserved

TEST REPORT

**Table F-C.2 of C/S T.007 Issue 5 Feb 2018
Position Data Encoding Results Standard Location Protocol**

Script Reference (See Table D.2)	Value of Encoded Location Bits Transmitted by Beacon	Confirmation that BCH Correct (V)
1	Bits 65-85 = 0FFBFF Bits 113-132 = 83E0F	V
2	Bits 65-85 = 100400 Bits 113-132 = 8420E Number of seconds after providing navigation data that beacon transmitted the above encoded location information: 48s	V
3	Bits 65-85 = 000000 Bits 113-132 = 8360D	V
4	Bits 65-85 = 000ACF Bits 113-132 = 0F222	V
5	Bits 65-85 = 0012CE Bits 113-132 = 93A60	V
6	Bits 65-85 = 100ECF Bits 113-132 = 0FA10	V
7	Bits 65-85 = 1B2964 Bits 113-132 = 80A00	V
8	Bits 65-85 = 1B2D64 Bits 113-132 = 84E00	V
9	Bits 65-85 = 0B46D0 Bits 113-132 = 03801	V
10	Bits 65-85 = 0B42D0 Bits 113-132 = 08009	V
11	Bits 65-85 = 14962A Bits 113-132 = 80200	V
Self-Test Navigation Test Scripts		
12	Bits 65-85 = 0FFBFF Bits 113-132 = 83E0F	V
13	Bits 65-85 = 0FFBFF Bits 113-132 = 83E0F	V

Copyright © Orolia S.A.S. All rights reserved

TEST REPORT

**Table F-C.3 of C/S T.007 Issue 5 Feb 2018
Position Data Encoding Results National Location Protocol**

Script Reference (See Table D.3)	Value of Encoded Location Bits Transmitted by Beacon	Confirmation that BCH Correct (V)
1	Bits 59-85 = 3F81FE0 Bits 113-126 = 27CF	V
2	Bits 59-85 = 4002000 Bits 113-126 = 284E Number of seconds after providing navigation data that beacon transmitted the above encoded location information: 48s	V
3	Bits 59-85 = 0000000 Bits 113-126 = 26CD	V
4	Bits 59-85 = 0019678 Bits 113-126 = 060D	V
5	Bits 59-85 = 001567A Bits 113-126 = 2710	V
6	Bits 59-85 = 401B677 Bits 113-126 = 0740	V
7	Bits 59-85 = 6CA0B20 Bits 113-126 = 06C0	V
8	Bits 59-85 = 6CA2B20 Bits 113-126 = 21C0	V
9	Bits 59-85 = 2D03680 Bits 113-126 = 0701	V
10	Bits 59-85 = 2CF5680 Bits 113-126 = 2009	V
11	Bits 59-85 = 523F14F Bits 113-126 = 2040	V
Self-Test Navigation Test Scripts		
12	Bits 59-85 = 3F81FE0 Bits 113-126 = 27CF	V
13	Bits 59-85 = 3F81FE0 Bits 113-126 = 27CF	V

Copyright © Orolia S.A.S. All rights reserved



TEST REPORT

6 Photographs

Not applicable.

7 Test Equipment Used

The following test equipment was used during the execution of the test procedure:

<u>Type</u>	<u>Description</u>	<u>Calibration due</u>
Antenna Load	50 ohm RF attenuator	Not applicable
Beacon Tester	BT100AVS S/N: 2835	18-Nov-2018
NMEA String Generator	NMEA Transmit Simulator SW Version V1.8 Build 65 running on Windows PC	Not applicable
Power Supply	ISO-TECH IPS 405 S/N: 523D097G1	Not applicable

8 Other Technical Information

Not applicable.

9 Technical data submitted by Beacon manufacturer

Not applicable

ANNEX B

Battery Current Comparison Measurements

Test measurements within this report have been carried out in Modification State 0 (reference TUV SUD document 75942209 Report 1) with limited repeat measurements made in Modification State 1. The table below displays the difference in current draw between the two Modifications States:

Operating Mode	Modification State 0	Modification State 1	% Difference
	Average Current (mA)	Average Current (mA)	Mod State 1 to 0
1, Standby	0.00001455	0.00001462	0.48
2, ON at EUT switch (GPS search)	57.19	54	-5.58
3, ON at EUT (GPS Sleep)	47.69	45.14	-5.35
4, On at EUT switch (A2 +A3)	55.84	52.46	-6.05
5, Self-test	50.97	40.08	-21.37
6, GNSS Self-test (Timeout)	18.17	18.71	2.97
7, GNSS Self-test (Burst)	27.84	24.94	-10.42
8, On at EUT + Strobe Morse Code	52.23	52.37	0.27
9, TEST button held (continuous)	17.89	18.27	2.12

Comments:

Measurements conclude that the average currents in Modification State 1 are generally comparable or lower than those measured for Modification State 0.