

Electromagnetic Emissions Test Report

*Application for Grant of Equipment Authorization
pursuant to*

FCC Part 15 Subpart C

*on the
Savi Technology, Inc.
Transmitter*

Model: ST-675-SIAD-001

FCC ID: KL7-675T-SIAD

GRANTEE: Savi Technology, Inc.
351 E. Evelyn Ave.
Mountain View, CA 94041

TEST SITE: Elliott Laboratories
684 W. Maude Ave
Sunnyvale, CA 94086

REPORT DATE: September 4, 2008

FINAL TEST DATE: August 27, 2008

AUTHORIZED SIGNATORY:



Mark Briggs
Staff Engineer



Testing Cert #2016-01

Elliott Laboratories is accredited by the A2LA, certificate number 2016-01, to perform the test(s) listed in this report. This report shall not be reproduced, except in its entirety, without the written approval of Elliott Laboratories

REVISION HISTORY

Rev #	Date	Comments	Modified By
1	September 16, 2008	Initial Release	David Guidotti

TABLE OF CONTENTS

COVER PAGE.....1

REVISION HISTORY2

TABLE OF CONTENTS3

SCOPE.....5

OBJECTIVE5

STATEMENT OF COMPLIANCE.....6

TEST RESULTS SUMMARY6

 RFID DEVICES OPERATING IN THE 433.5 – 434.5MHZ BANDS.....6

 GENERAL REQUIREMENTS APPLICABLE TO ALL BANDS7

MEASUREMENT UNCERTAINTIES.....7

EQUIPMENT UNDER TEST (EUT) DETAILS.....8

 GENERAL.....8

 OTHER EUT DETAILS.....8

 ANTENNA SYSTEM8

 ENCLOSURE.....8

 MODIFICATIONS.....9

 SUPPORT EQUIPMENT.....9

 EUT INTERFACE PORTS9

 EUT OPERATION.....9

TEST SITE.....10

 GENERAL INFORMATION.....10

 RADIATED EMISSIONS CONSIDERATIONS10

MEASUREMENT INSTRUMENTATION11

 RECEIVER SYSTEM11

 INSTRUMENT CONTROL COMPUTER.....11

 LINE IMPEDANCE STABILIZATION NETWORK (LISN)11

 FILTERS/ATTENUATORS12

 ANTENNAS.....12

 ANTENNA MAST AND EQUIPMENT TURNTABLE.....12

 INSTRUMENT CALIBRATION.....12

TEST PROCEDURES13

 EUT AND CABLE PLACEMENT13

 RADIATED EMISSIONS.....13

 BANDWIDTH MEASUREMENTS16

 SPECIFICATION LIMITS AND SAMPLE CALCULATIONS.....17

 GENERAL TRANSMITTER RADIATED EMISSIONS SPECIFICATION LIMITS.....17

 SAMPLE CALCULATIONS - CONDUCTED EMISSIONS18

 SAMPLE CALCULATIONS - RADIATED EMISSIONS18

 SAMPLE CALCULATIONS - FIELD STRENGTH TO EIRP CONVERSION19

TABLE OF CONTENTS (Continued)

EXHIBIT 1: Test Equipment Calibration Data..... 1
EXHIBIT 2: Test Measurement Data..... 2
EXHIBIT 3: Photographs of Test Configurations..... 3
EXHIBIT 4: Proposed FCC ID Label & Label Location 4
EXHIBIT 5: Detailed Photographs..... 5
EXHIBIT 6: Operator's Manual 6
EXHIBIT 7: Block Diagram..... 7
EXHIBIT 8: Schematic Diagrams..... 8
EXHIBIT 9: Theory of Operation 9

SCOPE

An electromagnetic emissions test has been performed on the Savi Technology, Inc. model ST-675-SIAD-001 pursuant to the following rules:

FCC Part 15 Subpart C

Conducted and radiated emissions data has been collected, reduced, and analyzed within this report in accordance with measurement guidelines set forth in the following reference standards and as outlined in Elliott Laboratories test procedures:

ANSI C63.4:2003

The intentional radiator above has been tested in a simulated typical installation to demonstrate compliance with the relevant standards.

Final system data was gathered in a mode that tended to maximize emissions by varying orientation of EUT, orientation of power and I/O cabling, antenna search height, and antenna polarization.

Every practical effort was made to perform an impartial test using appropriate test equipment of known calibration. All pertinent factors have been applied to reach the determination of compliance.

The test results recorded herein are based on a single type test of the Savi Technology, Inc. model ST-675-SIAD-001 and therefore apply only to the tested sample. The sample was selected and prepared by Eugene Schlindwein of Savi Technology, Inc.

OBJECTIVE

The primary objective of the manufacturer is compliance with the regulations outlined in the previous section.

Prior to marketing in the USA, all unlicensed transmitters and transceivers require certification. Receive-only devices operating between 30 MHz and 960 MHz are subject to either certification or a manufacturer's declaration of conformity, with all other receive-only devices exempt from the technical requirements.

Certification is a procedure where the manufacturer submits test data and technical information to a certification body and receives a certificate or grant of equipment authorization upon successful completion of the certification body's review of the submitted documents. Once the equipment authorization has been obtained, the label indicating compliance must be attached to all identical units, which are subsequently manufactured.

Maintenance of compliance is the responsibility of the manufacturer. Any modification of the product which may result in increased emissions should be checked to ensure compliance has been maintained (i.e., printed circuit board layout changes, different line filter, different power supply, harnessing or I/O cable changes, etc.).

STATEMENT OF COMPLIANCE

The tested sample of Savi Technology, Inc. model ST-675-SIAD-001 complied with the requirements of the following regulations:

FCC Part 15 Subpart C

Maintenance of compliance is the responsibility of the manufacturer. Any modification of the product which may result in increased emissions should be checked to ensure compliance has been maintained (i.e., printed circuit board layout changes, different line filter, different power supply, harnessing or I/O cable changes, etc.).

TEST RESULTS SUMMARY

RFID DEVICES OPERATING IN THE 433.5 – 434.5MHz BANDS

FCC Rule Part	RSS Rule Part	Description	Measured Value / Comments	Limit / Requirement	Result
15.240 (a)	RSS 210 A5	Location of operation	See note 2	Must be limited to commercial and industrial areas	Not applicable
15.240 (f)	-	Information to user		Notification of geographic limitations	Not applicable
15.240 (b)	RSS 210 A5 (1)	Duration of transmissions	See note 1	< 60s with 10s silent period	Complies
15.240 (b)	RSS 210 A5 (2)	Fundamental Signal Strength	2291uV/m avg 9120uV/m pk	11000uV/m avg 55000uV/m pk	Complies
15.240 (c) / 15.209	RSS 210 Table 2	Radiated Spurious Emissions, 30 MHz – 4339 MHz	43.0dBµV/m @ 867.83MHz	FCC 15.209 RSS 210 Table 2	Complies (-3dB)
	RSP 100 RSS GEN 4.4.1	99% Bandwidth	198 kHz	Information only	Not applicable

Note 1 – Refer to the operational description included with this application for detailed description and timing diagrams for transmission duration.

Note 2 – The Tag will only transmit under 15.240 in response to a fixed reader that sends transmissions under 15.240. Location of operation and information to user is therefore incumbent on the reader and not the tag. Savi's readers that operate under 15.240 have the appropriate geographical limitations and user manual information.

GENERAL REQUIREMENTS APPLICABLE TO ALL BANDS

FCC Rule Part	RSS Rule part	Description	Measured Value / Comments	Limit / Requirement	Result (margin)
15.203	-	RF Connector	Antenna is integral to the device	Integral antenna or unique connector	Complies
15.109	RSS GEN 7.2.3 Table 1	Receiver spurious emissions	30.7dB μ V/m @ 423.23MHz (-15.3dB)	15.109	Complies (- 15dB)
15.207	RSS GEN Table 2	AC Conducted Emissions	Not applicable, device is battery powered with no provisions from being powered from the AC mains		N/A
15.247 (b) (5) 15.407 (f)	RSS 102	RF Exposure Requirements	Not applicable, exempt from rf exposure requirements	Refer to OET 65, FCC Part 1	Complies

MEASUREMENT UNCERTAINTIES

ISO/IEC 17025 requires that an estimate of the measurement uncertainties associated with the emissions test results be included in the report. The measurement uncertainties given below are based on a 95% confidence level and were calculated in accordance with UKAS document LAB 34.

Measurement Type	Frequency Range (MHz)	Calculated Uncertainty (dB)
Radiated Emissions	30 to 1000	± 3.6
Radiated Emissions	1000 to 40000	± 6.0

EQUIPMENT UNDER TEST (EUT) DETAILS

GENERAL

The Savi Technology, Inc. model ST-675-SIAD-001 is a RFID tag that contains a transceiver operating at 433.92MHz. The receiver LO operates at 423.22MHz. The device also contains a receiver operating at 123kHz. Normally, the EUT would be mounted to a container in a specific orientation. The EUT was placed on a table in this orientation during testing.

The device is designed to operate under FCC 15.231(a) (control signals), 15.231(e) (data signals) and 15.240 (RFID). The maximum operating duty cycle is 25% when operating under 15.240 and 15.231(a) and 10% when operating under 15.231(e). The operational description describes the various modes and compliance with the various requirements for timing and transmission content of the various rules parts.

The sample was received on August 27, 2008 and tested on August 27, 2008. The EUT consisted of the following component(s):

Manufacturer	Model	Description	Serial Number	FCC ID
Savi	ST-675-SIAD-001	RFID Tag	5708499	KL7-675T-SIAD

OTHER EUT DETAILS

- The ST-675-SIAD-001 is a design variant of the previously-approved ST-675-I except with a longer ribbon cable between the UHF antenna case and the active electronics case. [ATCB Grant KL7-676T-V1 of 12/08/05] This report is to verify that the UHF emissions remain in compliance after the design modification. Digital signals are not carried in the ribbon cable, so digital emissions are not affected in comparison to the original report.
- Both devices are RFID Tags intended for mounting on ISO container doors. The active circuit card and battery are housed in a case inside the locked door to prevent vandalism and theft of the battery. The UHF and Low Frequency Antennas and an audible buzzer are mounted in a protective low profile plastic case on the outside of the door. A shielded flat ribbon cable connects the Antenna signals to the active circuit card.

ANTENNA SYSTEM

The antenna is integral to the device, thereby meeting the requirements of FCC 15.203.

ENCLOSURE

The EUT enclosure is primarily constructed of plastic covers over all circuitry/antenna, secured to a steel bracket. It measures approximately 19 cm wide by 10 cm deep by 12 cm high.

MODIFICATIONS

The EUT did not require modifications during testing in order to comply with emissions specifications.

SUPPORT EQUIPMENT

No support equipment was used during emissions testing.

EUT INTERFACE PORTS

The I/O cabling configuration during emissions testing was as follows:

Port	Connected To	Cable(s)		
		Description	Shielded or Unshielded	Length(m)
None	-	-	-	-

EUT OPERATION

Transmitter set to continuously transmit at 433 MHz for transmitter-related tests and in a continuous receive mode for receiver-related tests.

TEST SITE

GENERAL INFORMATION

Final test measurements were taken on August 27, 2008 at the Elliott Laboratories Open Area Test Site #2 or semi anechoic chamber #2 located at 684 West Maude Avenue, Sunnyvale, California or 41039 Boyce Road, Fremont, California Pursuant to section 2.948 of the FCC's Rules and section 3.3 of RSP-100, construction, calibration, and equipment data has been filed with the Commission.

ANSI C63.4:2003 recommends that ambient noise at the test site be at least 6 dB below the allowable limits. Ambient levels are below this requirement with the exception of predictable local TV, radio, and mobile communications traffic. The test site contains separate areas for radiated and conducted emissions testing. Considerable engineering effort has been expended to ensure that the facilities conform to all pertinent requirements of ANSI C63.4:2003.

RADIATED EMISSIONS CONSIDERATIONS

The FCC has determined that radiation measurements made in a shielded enclosure are not suitable for determining levels of radiated emissions. Radiated measurements are performed in an open field environment or in a semi-anechoic chamber. The test sites are maintained free of conductive objects within the CISPR defined elliptical area incorporated in ANSI C63.4:2003 guidelines and meet the Normalized Site Attenuation (NSA) requirements of ANSI C63.4:2003.

MEASUREMENT INSTRUMENTATION

RECEIVER SYSTEM

An EMI receiver as specified in CISPR 16-1 is used for emissions measurements. The receivers used can measure over the frequency range of 9 kHz up to 2000 MHz. These receivers allow both ease of measurement and high accuracy to be achieved. The receivers have Peak, Average, and CISPR (Quasi-peak) detectors built into their design so no external adapters are necessary. The receiver automatically sets the required bandwidth for the CISPR detector used during measurements. If the repetition frequency of the signal being measured is below 20Hz, peak measurements are made in lieu of Quasi-Peak measurements.

For measurements above the frequency range of the receivers, a spectrum analyzer is utilized because it provides visibility of the entire spectrum along with the precision and versatility required to support engineering analysis. Average measurements above 1000MHz are performed on the spectrum analyzer using the linear-average method with a resolution bandwidth of 1 MHz and a video bandwidth of 10 Hz, unless the signal is pulsed in which case the average (or video) bandwidth of the measuring instrument is reduced to onset of pulse desensitization and then increased.

INSTRUMENT CONTROL COMPUTER

The receivers utilize either a Rohde & Schwarz EZM Spectrum Monitor/Controller or contain an internal Spectrum Monitor/Controller to view and convert the receiver measurements to the field strength at an antenna or voltage developed at the LISN measurement port, which is then compared directly with the appropriate specification limit. This provides faster, more accurate readings by performing the conversions described under Sample Calculations within the Test Procedures section of this report. Results are printed in a graphic and/or tabular format, as appropriate. A personal computer is used to record all measurements made with the receivers.

The Spectrum Monitor provides a visual display of the signal being measured. In addition, the controller or a personal computer run automated data collection programs which control the receivers. This provides added accuracy since all site correction factors, such as cable loss and antenna factors are added automatically.

LINE IMPEDANCE STABILIZATION NETWORK (LISN)

Line conducted measurements utilize a fifty microhenry Line Impedance Stabilization Network as the monitoring point. The LISN used also contains a 250 uH CISPR adapter. This network provides for calibrated radio frequency noise measurements by the design of the internal low pass and high pass filters on the EUT and measurement ports, respectively.

FILTERS/ATTENUATORS

External filters and precision attenuators are often connected between the receiving antenna or LISN and the receiver. This eliminates saturation effects and non-linear operation due to high amplitude transient events.

ANTENNAS

A loop antenna is used below 30 MHz. For the measurement range 30 MHz to 1000 MHz either a combination of a biconical antenna and a log periodic or a bi-log antenna is used. Above 1000 MHz, horn antennas are used. The antenna calibration factors to convert the received voltage to an electric field strength are included with appropriate cable loss and amplifier gain factors to determine an overall site factor, which is then programmed into the test receivers or incorporated into the test software.

ANTENNA MAST AND EQUIPMENT TURNTABLE

The antennas used to measure the radiated electric field strength are mounted on a non-conductive antenna mast equipped with a motor-drive to vary the antenna height. Measurements below 30 MHz are made with the loop antenna at a fixed height of 1m above the ground plane.

ANSI C63.4:2003 specifies that the test height above ground for table mounted devices shall be 80 centimeters. Floor mounted equipment shall be placed on the ground plane if the device is normally used on a conductive floor or separated from the ground plane by insulating material from 3 to 12 mm if the device is normally used on a non-conductive floor. During radiated measurements, the EUT is positioned on a motorized turntable in conformance with this requirement.

INSTRUMENT CALIBRATION

All test equipment is regularly checked to ensure that performance is maintained in accordance with the manufacturer's specifications. All antennas are calibrated at regular intervals with respect to tuned half-wave dipoles. An exhibit of this report contains the list of test equipment used and calibration information.

TEST PROCEDURES

EUT AND CABLE PLACEMENT

The regulations require that interconnecting cables be connected to the available ports of the unit and that the placement of the unit and the attached cables simulate the worst case orientation that can be expected from a typical installation, so far as practicable. To this end, the position of the unit and associated cabling is varied within the guidelines of ANSI C63.4:2003, and the worst-case orientation is used for final measurements.

RADIATED EMISSIONS

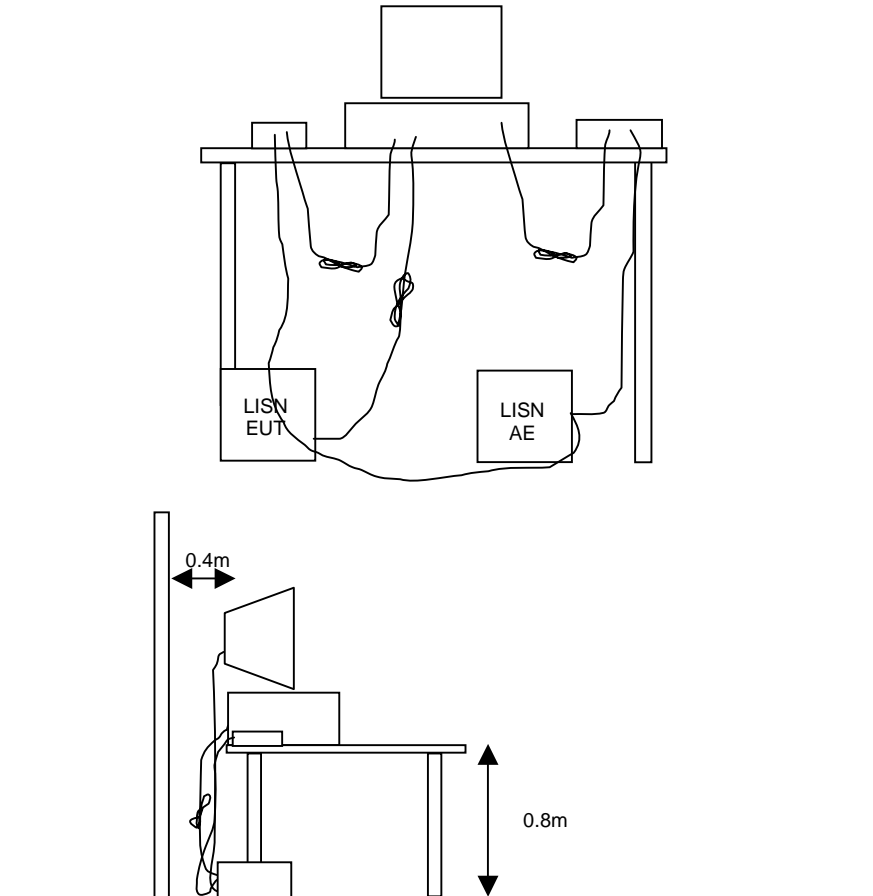

A preliminary scan of the radiated emissions is performed in which all significant EUT frequencies are identified with the system in a nominal configuration. At least two scans are performed, one scan for each antenna polarization (horizontal and vertical; loop parallel and perpendicular to the EUT). During the preliminary scans, the EUT is rotated through 360°, the antenna height is varied (for measurements above 30 MHz) and cable positions are varied to determine the highest emission relative to the limit. Preliminary scans may be performed in a fully anechoic chamber for the purposes of identifying the frequencies of the highest emissions from the EUT.

A speaker is provided in the receiver to aid in discriminating between EUT and ambient emissions. Other methods used during the preliminary scan for EUT emissions involve scanning with near field magnetic loops, monitoring I/O cables with RF current clamps, and cycling power to the EUT.

Final maximization is a phase in which the highest amplitude emissions identified in the spectral search are viewed while the EUT azimuth angle is varied from 0 to 360 degrees relative to the receiving antenna. The azimuth, which results in the highest emission is then maintained while varying the antenna height from one to four meters (for measurements above 30 MHz, measurements below 30 MHz are made with the loop antenna at a fixed height of 1m). The result is the identification of the highest amplitude for each of the highest peaks. Each recorded level is corrected in the receiver using appropriate factors for cables, connectors, antennas, and preamplifier gain.

When testing above 18 GHz, the receive antenna is located at 1 meter from the EUT and the antenna height is restricted to a maximum of 2.5 meters.

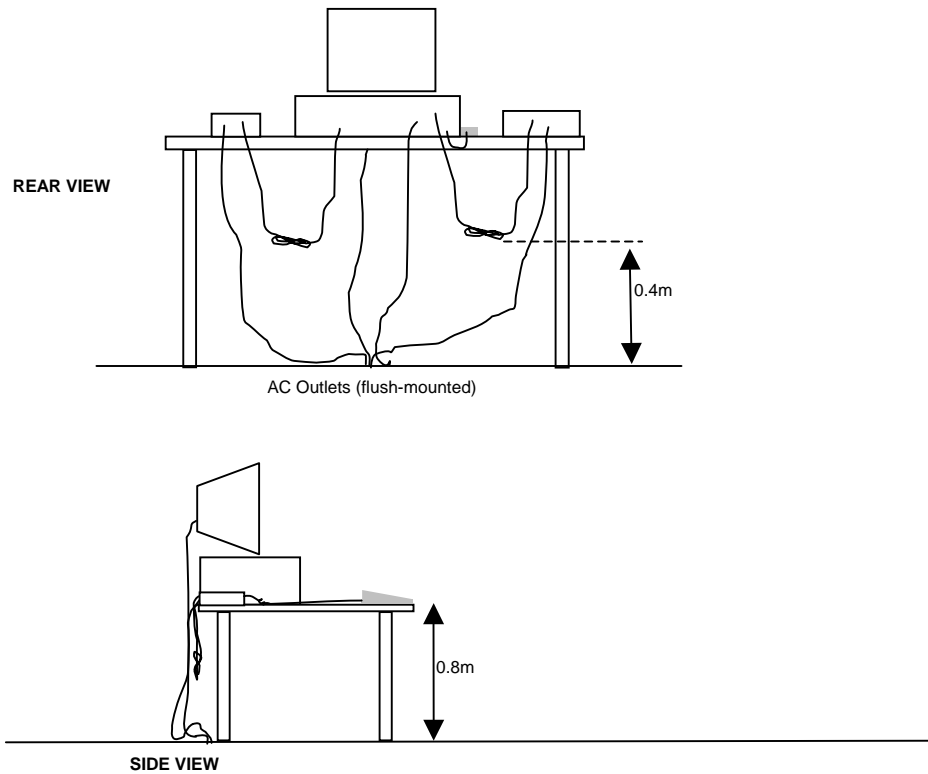

Typical Test Configuration for Radiated Field Strength Measurements

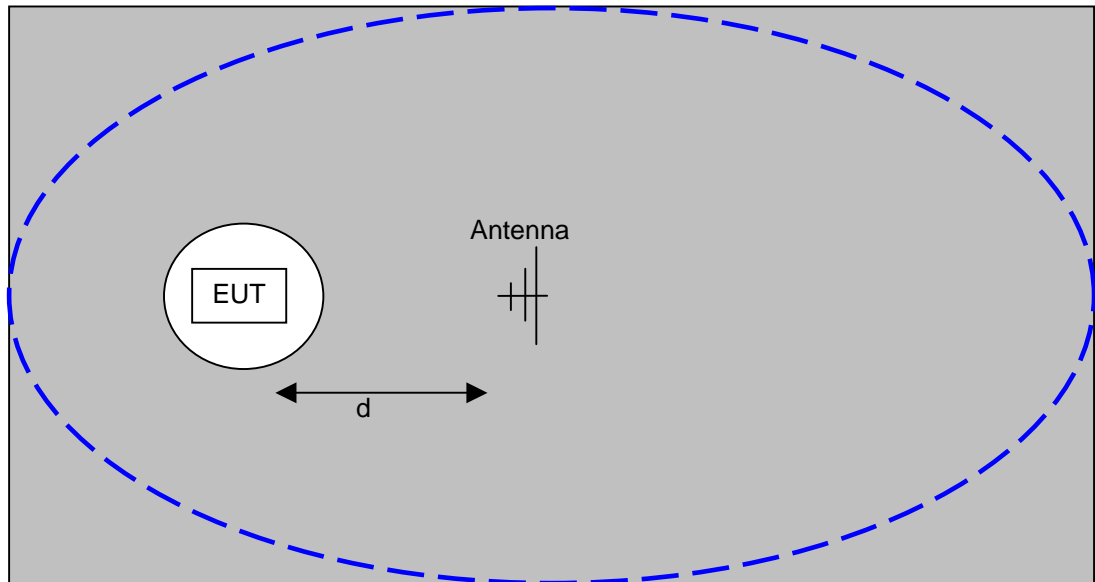

The ground plane extends beyond the ellipse defined in CISPR 16 / CISPR 22 / ANSI C63.4 and is large enough to accommodate test distances (d) of 3m and 10m. Refer to the test data tables for the actual measurement distance.

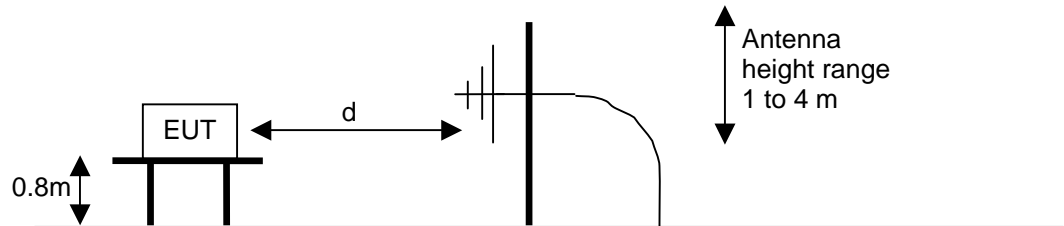

Test Configuration for Radiated Field Strength Measurements
OATS- Plan and Side Views

BANDWIDTH MEASUREMENTS

The 6dB, 20dB and/or 26dB signal bandwidth is measured in using the bandwidths recommended by ANSI C63.4. When required, the 99% bandwidth is measured using the methods detailed in RSS GEN.

SPECIFICATION LIMITS AND SAMPLE CALCULATIONS

The limits for conducted emissions are given in units of microvolts, and the limits for radiated emissions are given in units of microvolts per meter at a specified test distance. Data is measured in the logarithmic form of decibels relative to one microvolt, or dB microvolts (dBuV). For radiated emissions, the measured data is converted to the field strength at the antenna in dB microvolts per meter (dBuV/m). The results are then converted to the linear forms of uV and uV/m for comparison to published specifications.

For reference, converting the specification limits from linear to decibel form is accomplished by taking the base ten logarithm, then multiplying by 20. These limits in both linear and logarithmic form are as follows:

GENERAL TRANSMITTER RADIATED EMISSIONS SPECIFICATION LIMITS

The table below shows the limits for the spurious emissions from transmitters that fall in restricted bands¹ (with the exception of transmitters operating under FCC Part 15 Subpart D and RSS 210 Annex 9), the limits for all emissions from a low power device operating under the general rules of RSS 310 (tables 3 and 4), RSS 210 (table 2) and FCC Part 15 Subpart C section 15.209.

Frequency Range (MHz)	Limit (uV/m)	Limit (dBuV/m @ 3m)
30 to 88	100 @ 3m	40 @ 3m
88 to 216	150 @ 3m	43.5 @ 3m
216 to 960	200 @ 3m	46.0 @ 3m
Above 960	500 @ 3m	54.0 @ 3m

¹ The restricted bands are detailed in FCC 15.203, RSS 210 Table 1 and RSS 310 Table 2

SAMPLE CALCULATIONS - CONDUCTED EMISSIONS

Receiver readings are compared directly to the conducted emissions specification limit (decibel form) as follows:

$$R_r - S = M$$

where:

R_r = Receiver Reading in dBuV

S = Specification Limit in dBuV

M = Margin to Specification in +/- dB

SAMPLE CALCULATIONS - RADIATED EMISSIONS

Receiver readings are compared directly to the specification limit (decibel form). The receiver internally corrects for cable loss, preamplifier gain, and antenna factor. The calculations are in the reverse direction of the actual signal flow, thus cable loss is added and the amplifier gain is subtracted. The Antenna Factor converts the voltage at the antenna coaxial connector to the field strength at the antenna elements.

A distance factor, when used for electric field measurements above 30MHz, is calculated by using the following formula:

$$F_d = 20 * \text{LOG}_{10} (D_m/D_s)$$

where:

F_d = Distance Factor in dB

D_m = Measurement Distance in meters

D_s = Specification Distance in meters

For electric field measurements below 30MHz the extrapolation factor is either determined by making measurements at multiple distances or a theoretical value is calculated using the formula:

$$F_d = 40 * \text{LOG}_{10} (D_m/D_s)$$

Measurement Distance is the distance at which the measurements were taken and Specification Distance is the distance at which the specification limits are based. The antenna factor converts the voltage at the antenna coaxial connector to the field strength at the antenna elements.

The margin of a given emission peak relative to the limit is calculated as follows:

$$R_c = R_r + F_d$$

and

$$M = R_c - L_s$$

where:

$$R_r = \text{Receiver Reading in dBuV/m}$$

$$F_d = \text{Distance Factor in dB}$$

$$R_c = \text{Corrected Reading in dBuV/m}$$

$$L_s = \text{Specification Limit in dBuV/m}$$

$$M = \text{Margin in dB Relative to Spec}$$

SAMPLE CALCULATIONS - FIELD STRENGTH TO EIRP CONVERSION

Where the radiated electric field strength is expressed in terms of the equivalent isotropic radiated power (eirp), or where a field strength measurement of output power is made in lieu of a direct measurement, the following formula is used to convert between eirp and field strength at a distance of 3m from the equipment under test:

$$E = \frac{1000000 \sqrt{30 P}}{3} \quad \text{microvolts per meter}$$

where P is the eirp (Watts)

EXHIBIT 1: Test Equipment Calibration Data

1 Page

Radiated Emissions, 30 - 4,340 MHz, 27-Aug-08

Engineer: Mehran Birgani

<u>Manufacturer</u>	<u>Description</u>	<u>Model #</u>	<u>Asset #</u>	<u>Cal Due</u>
EMCO	Log Periodic Antenna, 0.3-1 GHz	3146A	364	13-Dec-08
Hewlett Packard	EMC Spectrum Analyzer, 9 kHz - 6.5 GHz	8595EM	780	09-Oct-08
Hewlett Packard	Microwave Preamplifier, 1-26.5GHz	8449B	785	06-Jun-09
Filtek	Filter, 1 GHz High Pass	HP12/1000-5BA	957	30-Jul-09
EMCO	Antenna, Horn, 1-18 GHz (SA40-Red)	3115	1142	15-Jul-10
Rohde & Schwarz	Test Receiver, 0.009-2750 MHz	ESN	1332	29-Jan-09
EMCO	Biconical Antenna, 30-300 MHz	3110B	1497	03-Sep-08

EXHIBIT 2: Test Measurement Data

10 Pages



EMC Test Data

Client:	Savi Technology	Job Number:	J72802
Model:	ST-675-SIAD-001	T-Log Number:	T72869
		Account Manager:	Dean Eriksen
Contact:	Eugene Schlindwein		Mark Briggs
Emissions Standard(s):	FCC 15.231, FCC 15.240	Class:	N/A
Immunity Standard(s):	N/A	Environment:	-

EMC Test Data

For The

Savi Technology

Model

ST-675-SIAD-001

Date of Last Test: 9/8/2008

Client:	Savi Technology	Job Number:	J72802
Model:	ST-675-SIAD-001	T-Log Number:	T72869
Contact:	Eugene Schlindwein	Account Manger:	Dean Eriksen
Emissions Standard(s):	FCC 15.231, FCC 15.240	Class:	N/A
Immunity Standard(s):	N/A	Environment:	-

EUT INFORMATION

General Description

The EUT is a RFID tag that contains a transceiver operating at 433.92MHz and a receiver operating at 123kHz. The transceiver's receiver LO operates at 423.22 MHz. Normally, the EUT would be mounted to a container in a specific orientation. The EUT was placed on a table in this orientation during testing.

Equipment Under Test

Manufacturer	Model	Description	Serial Number	FCC ID
Savi	ST-675-SIAD-001	RFID Tag	5708499	-

EUT Antenna

The antenna is integral to the device, thereby meeting the requirements of FCC 15.203.

EUT Enclosure

The EUT enclosure is primarily constructed of plastic covers over all circuitry/antenna, secured to a steel bracket. It measures approximately 19 cm wide by 10 cm deep by 12 cm high.

Modification History

Mod. #	Test	Date	Modification
1			No modifications were made to the EUT during testing.

Modifications applied are assumed to be used on subsequent tests unless otherwise stated as a further modification.

Client:	Savi Technology	Job Number:	J72802
Model:	ST-675-SIAD-001	T-Log Number:	T72869
		Account Manger:	Dean Eriksen
Contact:	Eugene Schlindwein		
Emissions Standard(s):	FCC 15.231, FCC 15.240	Class:	N/A
Immunity Standard(s):	N/A	Environment:	-

Test Configuration #1

Local Support Equipment

Manufacturer	Model	Description	Serial Number	FCC ID
None	-	-	-	-

Remote Support Equipment

Manufacturer	Model	Description	Serial Number	FCC ID
None	-	-	-	-

Interface Cabling and Ports

Port	Connected To	Cable(s)		
		Description	Shielded or Unshielded	Length(m)
None	-	-	-	-

EUT Operation During Emissions Tests

Transmitter set to continuously transmit at 433 MHz for transmitter-related tests and in a continuous receive mode for receiver-related tests.

Client:	Savi Technology	Job Number:	J72802
Model:	ST-675-SIAD-001	T-Log Number:	T72869
Contact:	Eugene Schlindwein	Account Manager:	Dean Eriksen
Standard:	FCC 15.231, FCC 15.240	Class:	N/A

Radiated Emissions - FCC 15.231(e)

Test Specific Details

Objective: The objective of this test session is to perform final qualification testing of the EUT with respect to the specification listed above.

Date of Test: 08/27/08	Config. Used: 1
Test Engineer: Mehran Birgani	Config Change: None
Test Location: SVOATS #2	EUT Voltage: Battery

General Test Configuration

The EUT was located on the turntable for radiated emissions testing.

The test distance and extrapolation factor (if applicable) are detailed under each run description.

Note, **preliminary** testing indicates that the emissions were maximized by orientation of the EUT and elevation of the measurement antenna. **Maximized** testing indicated that the emissions were maximized by orientation of the EUT, elevation of the measurement antenna, and manipulation of the EUT's interface cables.

Ambient Conditions:

Temperature:	24 °C
Rel. Humidity:	36 %

Summary of Results

Run #	Test Performed	Limit	Result	Value / Margin
1	Fundamental Signal Field Strength	FCC 15.231(e)	Pass	59.2dB μ V/m @ 433.92MHz (-13.7dB)
1	Transmitter Radiated Spurious Emissions, 30 - 43404 MHz	FCC 15.209,15.231(e)	Pass	43.0dB μ V/m @ 867.83MHz (-9.9dB)
2	20dB Bandwidth	FCC 15.231	Pass	458 kHz

Modifications Made During Testing

No modifications were made to the EUT during testing

Deviations From The Standard

No deviations were made from the requirements of the standard.

Frequency Range	Test Distance	Limit Distance	Extrapolation Factor
30 - 4,340 MHz	3	3	0.0

Client:	Savi Technology	Job Number:	J72802
Model:	ST-675-SIAD-001	T-Log Number:	T72869
Contact:	Eugene Schlindwein	Account Manager:	Dean Eriksen
Standard:	FCC 15.231, FCC 15.240	Class:	N/A

Run #1: Preliminary Radiated Emissions, 30 - 4340 MHz, Transmitter Spurious Emissions

- Note: The limits for devices operating under 15.231 are calculated in the table below. The limits for 15.231(e) are for all other devices provided that they meet the requirements of 15.231(e). Spurious emissions falling in restricted bands must comply with the 15.209 limit, all other spurious emissions must comply with the higher of the limit calculated below or the 15.209 limit.
- Note: The field strength of any spurious emissions may not exceed the field strength of the fundamental signal.

Frequency (MHz)	15.231(b) Limits			15.231(e) Limits		
	Fundamental uV/m	Spurious dBuV/m	Spurious dBuV/m	Fundamental uV/m	Spurious dBuV/m	Spurious dBuV/m
433.92	10996.7	80.8	60.8	4398.7	72.9	52.9

- Note: The field strength of any spurious emissions may not exceed the 15.209 limit when the spurious emission falls in a restricted band. Additionally the spurious emissions can exceed the limit calculated above if the 15.209 limit is higher.

Fundamental Field Strength (433.9 MHz)

Frequency	Level	Pol	RSS 210 / FCC 15.209		Detector	Azimuth	Height	Comments
MHz	dBuV/m	V/H	Limit	Margin	Pk/QP/Avg	degrees	meters	
433.917	59.2	V	72.9	-13.7	Avg	267	1.0	
433.917	53.5	H	72.9	-19.4	Avg	143	3.2	
433.917	79.2	V	92.9	-13.7	PK	267	1.0	PK (0.10s)
433.917	73.5	H	92.9	-19.4	PK	143	3.2	PK (0.10s)

- Note 1: Average values calculated from the peak field strength measurements based on a duty cycle of 10%.

Client:	Savi Technology	Job Number:	J72802
Model:	ST-675-SIAD-001	T-Log Number:	T72869
Contact:	Eugene Schlindwein	Account Manager:	Dean Eriksen
Standard:	FCC 15.231, FCC 15.240	Class:	N/A

Spurious Emissions

Frequency	Level	Pol	RSS 210 / FCC 15.209		Detector	Azimuth	Height	Comments
MHz	dB μ V/m	V/H	Limit	Margin	Pk/QP/Avg	degrees	meters	
867.830	43.0	V	52.9	-9.9	QP	89	1.1	QP (1.0s)
867.830	35.0	H	52.9	-17.9	QP	261	2.3	QP (1.0s)
1301.650	33.0	H	54.0	-21.0	Avg	57	1.0	
1301.650	32.4	V	54.0	-21.6	Avg	68	1.1	
1735.590	29.6	H	54.0	-24.4	Avg	89	1.9	Note 2:
1735.590	27.3	V	54.0	-26.7	Avg	19	1.0	Note 2:
2169.540	31.4	V	54.0	-22.6	Avg	93	1.1	Note 2:
2169.560	32.1	H	54.0	-21.9	Avg	112	2.3	Note 2:
3037.410	30.1	H	54.0	-23.9	Avg	83	1.2	Note 2:
3037.440	29.6	V	54.0	-24.4	Avg	32	1.0	Note 2:
1301.650	53.0	H	74.0	-21.0	PK	57	1.0	
1301.650	52.4	V	74.0	-21.6	PK	68	1.1	
1735.590	49.6	H	74.0	-24.4	PK	89	1.9	Note 2:
1735.590	47.3	V	74.0	-26.7	PK	19	1.0	Note 2:
2169.540	51.4	V	74.0	-22.6	PK	93	1.1	Note 2:
2169.560	52.1	H	74.0	-21.9	PK	112	2.3	Note 2:
3037.410	50.1	H	74.0	-23.9	PK	83	1.2	Note 2:
3037.440	49.6	V	74.0	-24.4	PK	32	1.0	Note 2:

Note 1:	QP detector used below 1GHz, Peak and average detectors above 1GHz. If the peak measurement is below the average limit no average measurements are required.
Note 2:	Limit in restricted bands is the FCC 15.209 general limit. This signal is not in a restricted band and so is subject to the higher of either 52.9dB μ V/m or the general limit, so the general limit is used above 1GHz.
Note 3:	Average values calculated from the peak field strength measurements based on a duty cycle of 10%.

Client: Savi Technology	Job Number: J72802
Model: ST-675-SIAD-001	T-Log Number: T72869
Contact: Eugene Schlindwein	Account Manager: Dean Eriksen
Standard: FCC 15.231, FCC 15.240	Class: N/A

Run #2: Bandwidth Measurement(s)

Compliance with 15.231 bandwidth and transmit time requirements

Power Setting	Frequency (MHz)	Resolution Bandwidth	Video Bandwidth	20dB BW (kHz)	15.231 Limit (kHz)
R20 =18k	433.92	100 kHz	100 kHz	458 kHz	1084.8

Note 1: 20dB bandwidth measured using a resolution bandwidth at least 1% of the maximum permitted bandwidth.

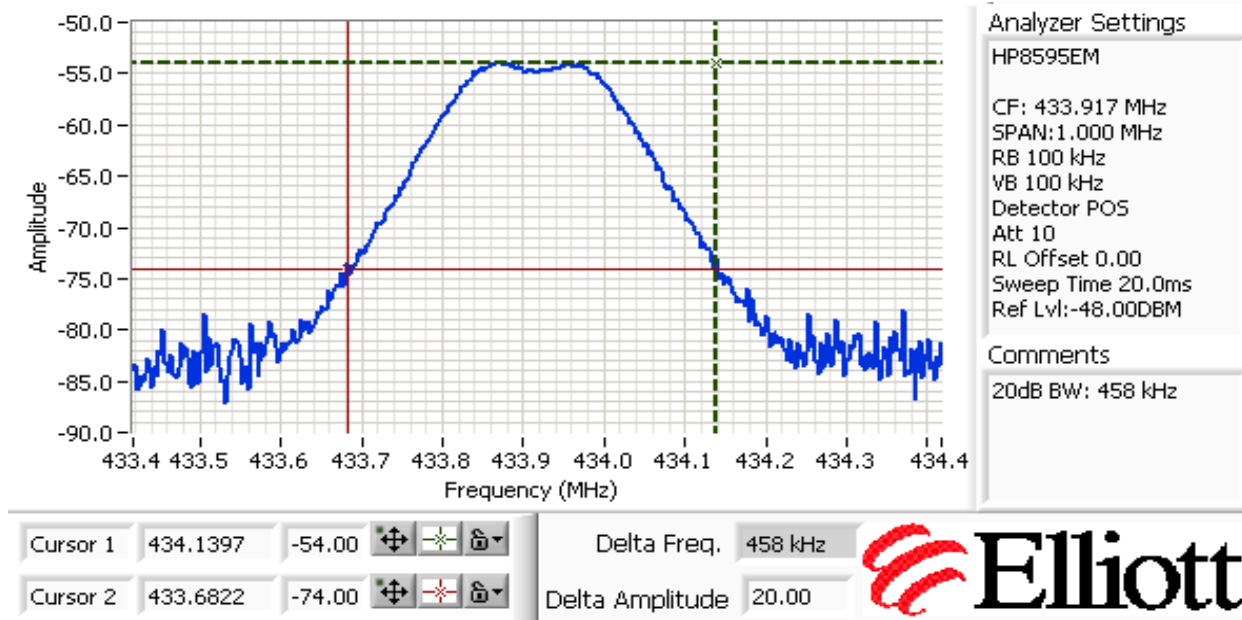

Compliance with 15.231 duration of transmissions and time between transmissions:

Refer to the operational description for plots and detailed description as to how the device complies with the transmit time and period between transmissions.

The device operates under 15.231(e). The maximum duration of a transmission is than 1 second and the period between transmissions is at least 30 times the maximum duration and never less than 10 seconds.

Client:	Savi Technology	Job Number:	J72802
Model:	ST-675-SIAD-001	T-Log Number:	T72869
		Account Manager:	Dean Eriksen
Contact:	Eugene Schlindwein		
Standard:	FCC 15.231, FCC 15.240	Class:	N/A

Radiated Emissions, FCC 15.240

Test Specific Details

Objective: The objective of this test session is to perform final qualification testing of the EUT with respect to the specification listed above.

Date of Test: 08/27/08
 Test Engineer: Mehran Birgani
 Test Location: SVOATS #2

Config. Used: 1
 Config Change: None
 EUT Voltage: Battery

General Test Configuration

The EUT was located on the turntable for radiated emissions testing.

The test distance and extrapolation factor (if applicable) are detailed under each run description.

Note, **preliminary** testing indicates that the emissions were maximized by orientation of the EUT and elevation of the measurement antenna. **Maximized** testing indicated that the emissions were maximized by orientation of the EUT, elevation of the measurement antenna, and manipulation of the EUT's interface cables.

Ambient Conditions: Temperature: 24 °C
 Rel. Humidity: 36 %

Summary of Results

Run #	Test Performed	Limit	Result	Value / Margin
1	Fundamental Signal Field Strength	FCC 15.240	Pass	67.2dBμV/m @ 433.92MHz (-13.6dB)
1	Transmitter Radiated Spurious Emissions, 30 - 43404 MHz	FCC 15.209 & 15.240	Pass	43.0dBμV/m @ 867.83MHz (-3.0dB)

Modifications Made During Testing

No modifications were made to the EUT during testing

Deviations From The Standard

No deviations were made from the requirements of the standard.

Frequency Range	Test Distance	Limit Distance	Extrapolation Factor
30 - 4340 MHz	3	3	0.0

Client:	Savi Technology	Job Number:	J72802
Model:	ST-675-SIAD-001	T-Log Number:	T72869
Contact:	Eugene Schlindwein	Account Manager:	Dean Eriksen
Standard:	FCC 15.231, FCC 15.240	Class:	N/A

Run #1: Preliminary Radiated Emissions, 30 - 4340 MHz, Transmitter Spurious Emissions

Note: The average limit in 15.240 for the fundamental signal is 11,000uV/m (80.8dBuV/m). The peak limit is 55,000 uV/m (94.8dBuV/m). Spurious emissions must comply with the 15.209 limit.

Fundamental Field Strength

Frequency MHz	Level dBuV/m	Pol V/H	FCC 15.209		Detector Pk/QP/Avg	Azimuth degrees	Height meters	Comments
			Limit	Margin				
433.917	67.2	V	80.8	-13.6	Avg	267	1.0	
433.917	61.5	H	80.8	-19.3	Avg	143	3.2	
433.917	79.2	V	94.8	-15.6	PK	267	1.0	PK (0.10s)
433.917	73.5	H	94.8	-21.3	PK	143	3.2	PK (0.10s)

Note 1: Average values calculated from the peak field strength measurements based on a duty cycle of 25%.

Spurious Emissions

Frequency MHz	Level dBuV/m	Pol V/H	FCC 15.209		Detector Pk/QP/Avg	Azimuth degrees	Height meters	Comments
			Limit	Margin				
867.830	43.0	V	46.0	-3.0	QP	89	1.1	QP (1.0s)
867.830	35.0	H	46.0	-11.0	QP	261	2.3	QP (1.0s)
1301.650	41.0	H	54.0	-13.0	AVG	57	1.0	
1301.650	40.4	V	54.0	-13.6	AVG	68	1.1	
1735.590	37.6	H	54.0	-16.4	AVG	89	1.9	
1735.590	35.3	V	54.0	-18.7	AVG	19	1.0	
2169.540	39.4	V	54.0	-14.6	AVG	93	1.1	
2169.560	40.1	H	54.0	-13.9	AVG	112	2.3	
3037.410	38.1	H	54.0	-15.9	AVG	83	1.2	
3037.440	37.6	V	54.0	-16.4	AVG	32	1.0	
1301.650	53.0	H	74.0	-21.0	PK	57	1.0	
1301.650	52.4	V	74.0	-21.6	PK	68	1.1	
1735.590	49.6	H	74.0	-24.4	PK	89	1.9	
1735.590	47.3	V	74.0	-26.7	PK	19	1.0	
2169.540	51.4	V	74.0	-22.6	PK	93	1.1	
2169.560	52.1	H	74.0	-21.9	PK	112	2.3	
3037.410	50.1	H	74.0	-23.9	PK	83	1.2	
3037.440	49.6	V	74.0	-24.4	PK	32	1.0	

Note 1: QP detector used below 1GHz, Peak and average detectors above 1GHz. If the peak measurement is below the average limit no average measurements are required.

Note 2: Average values calculated from the peak field strength measurements based on a duty cycle of 25%.

Client:	Savi Technology	Job Number:	J72802
Model:	ST-675-SIAD-001	T-Log Number:	T72869
Contact:	Eugene Schlindwein	Account Manager:	Dean Eriksen
Standard:	FCC 15.231, FCC 15.240	Class:	N/A

Radiated Emissions - Receiver Spurious Emissions

Test Specific Details

Objective: The objective of this test session is to perform final qualification testing of the EUT with respect to the specification listed above.

Date of Test: 08/27/08	Config. Used: 1
Test Engineer: Mehran Birgani	Config Change: None
Test Location: SVOATS #2	EUT Voltage: Battery

General Test Configuration

The EUT was located on the turntable for radiated emissions testing.

The test distance and extrapolation factor (if applicable) are detailed under each run description.

Note, **preliminary** testing indicates that the emissions were maximized by orientation of the EUT and elevation of the measurement antenna. **Maximized** testing indicated that the emissions were maximized by orientation of the EUT, elevation of the measurement antenna, and manipulation of the EUT's interface cables.

Ambient Conditions:

Temperature:	24 °C
Rel. Humidity:	36 %

Summary of Results

Run #	Test Performed	Limit	Result	Value / Margin
1	Receiver Radiated Spurious Emissions, 30 - 1400 MHz	FCC 15.109	Pass	30.7dBµV/m @ 423.23MHz (-15.3dB)

Modifications Made During Testing

No modifications were made to the EUT during testing

Deviations From The Standard

No deviations were made from the requirements of the standard.

Run #1: Receiver Spurious Emissions

Frequency Range	Test Distance	Limit Distance	Extrapolation Factor
30 - 1300 MHz	3	3	0.0

Frequency MHz	Level dBµV/m	Pol V/H	FCC 15.109		Detector Pk/QP/Avg	Azimuth degrees	Height meters	Comments
			Limit	Margin				
423.225	30.7	H	46.0	-15.3	QP	309	1.0	QP (1.00s)
423.225	25.2	V	46.0	-20.8	QP	20	1.8	QP (1.00s)
846.450	27.1	H	46.0	-18.9	QP	0	1.0	QP (1.00s)- Noise Floor
846.450	27.0	V	46.0	-19.0	QP	0	1.0	QP (1.00s)- Noise Floor

EXHIBIT 3: Photographs of Test Configurations

EXHIBIT 4: Proposed FCC ID Label & Label Location

*EXHIBIT 5: Detailed Photographs
of Savi Technology, Inc. Model ST-675-SIAD-001 Construction*

*EXHIBIT 6: Operator's Manual
for Savi Technology, Inc. Model ST-675-SIAD-001*

***EXHIBIT 7: Block Diagram
of Savi Technology, Inc. Model ST-675-SIAD-001***

***EXHIBIT 8: Schematic Diagrams
for Savi Technology, Inc. Model ST-675-SIAD-001***

*EXHIBIT 9: Theory of Operation
for Savi Technology, Inc. Model ST-675-SIAD-001*