

*Electromagnetic Emissions Test Report
Application for Grant of Equipment Authorization
pursuant to
Industry Canada RSS-Gen Issue 2 / RSS 210 Issue 7
FCC Part 15 Subpart C
on the
Savi Technology, Inc.
Transmitter*

Models: ST-654-031, ST-654-031-NSN, ST-618-030, ST-618-032, ST-618-032-NSN, ST-621-030, ST-621-032, AND ST-621-032-NSN

UPN: 2404A-654T2
FCC ID: KL7-654T-V3

GRANTEE: Savi Technology, Inc.
351 E. Evelyn Ave.
Mountain View, CA 94041

TEST SITE(S): Elliott Laboratories
684 W. Maude Ave
Sunnyvale, CA 94086
IC Site Registration #: 2845A-2

REPORT DATE: December 8, 2008

FINAL TEST DATE: November 21 and November 24, 2008

AUTHORIZED SIGNATORY:



David W. Bare
Chief Engineer



Testing Cert #2016-01

Elliott Laboratories is accredited by the A2LA, certificate number 2016-01, to perform the test(s) listed in this report. This report shall not be reproduced, except in its entirety, without the written approval of Elliott Laboratories

REVISION HISTORY

Rev #	Date	Comments	Modified By
1	2/11/09	First Release	-

TABLE OF CONTENTS

COVER PAGE.....	1
REVISION HISTORY	2
TABLE OF CONTENTS	3
SCOPE.....	5
OBJECTIVE.....	6
STATEMENT OF COMPLIANCE.....	6
TEST RESULTS SUMMARY	7
RFID DEVICES OPERATING IN THE 433.5 – 434.5MHZ BANDS	7
GENERAL REQUIREMENTS APPLICABLE TO ALL BANDS.....	8
MEASUREMENT UNCERTAINTIES.....	9
EQUIPMENT UNDER TEST (EUT) DETAILS.....	10
GENERAL.....	10
OTHER EUT DETAILS.....	10
ANTENNA SYSTEM	10
ENCLOSURE.....	11
MODIFICATIONS.....	11
SUPPORT EQUIPMENT.....	11
EUT INTERFACE PORTS	11
EUT OPERATION	11
TEST SITE.....	12
GENERAL INFORMATION.....	12
RADIATED EMISSIONS CONSIDERATIONS	12
MEASUREMENT INSTRUMENTATION	13
RECEIVER SYSTEM	13
INSTRUMENT CONTROL COMPUTER	13
LINE IMPEDANCE STABILIZATION NETWORK (LISN).....	13
FILTERS/ATTENUATORS	14
ANTENNAS.....	14
ANTENNA MAST AND EQUIPMENT TURNTABLE.....	14
INSTRUMENT CALIBRATION.....	14
TEST PROCEDURES	14
EUT AND CABLE PLACEMENT	14
RADIATED EMISSIONS.....	15
BANDWIDTH MEASUREMENTS.....	16
SPECIFICATION LIMITS AND SAMPLE CALCULATIONS.....	17
GENERAL TRANSMITTER RADIATED EMISSIONS SPECIFICATION LIMITS	17
SAMPLE CALCULATIONS - RADIATED EMISSIONS.....	18
SAMPLE CALCULATIONS - FIELD STRENGTH TO EIRP CONVERSION.....	19

TABLE OF CONTENTS (Continued)

EXHIBIT 1: Test Equipment Calibration Data..... 1
EXHIBIT 2: Test Measurement Data..... 2
EXHIBIT 3: Photographs of Test Configurations..... 3
EXHIBIT 4: Proposed FCC ID Label & Label Location 4
EXHIBIT 5: Detailed Photographs..... 5
EXHIBIT 6: Operator's Manual 6
EXHIBIT 7: Block Diagram..... 7
EXHIBIT 8: Schematic Diagrams..... 8
EXHIBIT 9: Theory of Operation 9
EXHIBIT 10: Advertising Literature..... 10
EXHIBIT 11: RF Exposure Information 11

SCOPE

An electromagnetic emissions test has been performed on the Savi Technology, Inc. model ST-654-031 pursuant to the following rules:

Industry Canada RSS-Gen Issue 2
RSS 210 Issue 7 "Low-power Licence-exempt Radiocommunication Devices (All Frequency Bands): Category I Equipment"
FCC Part 15 Subpart C

Conducted and radiated emissions data has been collected, reduced, and analyzed within this report in accordance with measurement guidelines set forth in the following reference standards and as outlined in Elliott Laboratories test procedures:

ANSI C63.4:2003

The intentional radiator above has been tested in a simulated typical installation to demonstrate compliance with the relevant Industry Canada performance and procedural standards.

Final system data was gathered in a mode that tended to maximize emissions by varying orientation of EUT, orientation of power and I/O cabling, antenna search height, and antenna polarization.

Every practical effort was made to perform an impartial test using appropriate test equipment of known calibration. All pertinent factors have been applied to reach the determination of compliance.

The test results recorded herein are based on a single type test of the Savi Technology, Inc. model ST-654-031 and therefore apply only to the tested sample. The sample was selected and prepared by Eugene Schlindwein of Savi Technology, Inc.

OBJECTIVE

The primary objective of the manufacturer is compliance with the regulations outlined in the previous section.

Prior to marketing in the USA, all unlicensed transmitters and transceivers require certification. Receive-only devices operating between 30 MHz and 960 MHz are subject to either certification or a manufacturer's declaration of conformity, with all other receive-only devices exempt from the technical requirements.

Prior to marketing in Canada, Class I transmitters, receivers and transceivers require certification. Class II devices are required to meet the appropriate technical requirements but are exempt from certification requirements.

Certification is a procedure where the manufacturer submits test data and technical information to a certification body and receives a certificate or grant of equipment authorization upon successful completion of the certification body's review of the submitted documents. Once the equipment authorization has been obtained, the label indicating compliance must be attached to all identical units, which are subsequently manufactured.

Maintenance of compliance is the responsibility of the manufacturer. Any modification of the product which may result in increased emissions should be checked to ensure compliance has been maintained (i.e., printed circuit board layout changes, different line filter, different power supply, harnessing or I/O cable changes, etc.).

Testing was performed only on model ST-654-031. This model was considered representative of models ST-654-031-NSN, ST-618-030, ST-618-032, ST-618-032-NSN, ST-621-030, ST-621-032, and ST-621-032-NSN.

STATEMENT OF COMPLIANCE

The tested sample of Savi Technology, Inc. model ST-654-031 complied with the requirements of the following regulations:

- Industry Canada RSS-Gen Issue 2
- RSS 210 Issue 7 "Low-power Licence-exempt Radiocommunication Devices (All Frequency Bands): Category I Equipment"
- FCC Part 15 Subpart C

Maintenance of compliance is the responsibility of the manufacturer. Any modification of the product which may result in increased emissions should be checked to ensure compliance has been maintained (i.e., printed circuit board layout changes, different line filter, different power supply, harnessing or I/O cable changes, etc.).

TEST RESULTS SUMMARY**RFID DEVICES OPERATING IN THE 433.5 – 434.5MHz BANDS**

FCC Rule Part	RSS Rule Part	Description	Measured Value / Comments	Limit / Requirement	Result
15.240 (a)	RSS 210 A5	Location of operation	1	Must be limited to commercial and industrial areas	Complies
15.240 (f)	-	Information to user		Notification of geographic limitations	Complies
15.240 (b)	RSS 210 A5 (1)	Duration of transmissions	2	< 60s with 10s silent period	Complies
15.240 (b)	RSS 210 A5 (2)	Fundamental Signal Strength	79.7dB μ V/m (9660.5 μ V/m) @ 433.91MHz (-1.1dB)	11000uV/m avg 55000uV/m pk	Complies
15.240 (c) / 15.209	RSS 210 Table 2	Radiated Spurious Emissions, 30 MHz – 4400 MHz	45.1dB μ V/m (179.9 μ V/m) @ 867.83MHz (-0.9dB)	Refer to table in limits section	Complies

Note – As the device can be placed in any position on a container was tested in all three orthogonal orientations.

¹ The Tag will only transmit under 15.240 in response to a fixed reader that sends transmissions under 15.240.

Location of operation and information to user is therefore incumbent on the reader and not the tag. Savi's readers that operate under 15.240 have the appropriate geographical limitations and user manual information.

² Refer to the operational description included with this application for detailed description and timing diagrams for transmission duration

GENERAL REQUIREMENTS APPLICABLE TO ALL BANDS

FCC Rule Part	RSS Rule part	Description	Measured Value / Comments	Limit / Requirement	Result (margin)
15.203	-	RF Connector	Antenna is integral to the device	Integral antenna or non-standard connector if not professionally installed	Complies
15.109	RSS GEN 7.2.3 Table 1	Receiver spurious emissions	41.0dB μ V/m (112.2 μ V/m) @ 1268.4MHz (-13.0dB)	Refer to table in Standard	Complies
15.207	RSS GEN Table 2	AC Conducted Emissions	NA-battery operated	-	Complies
	RSS 102	RF Exposure Requirements	Refer to RSS 102 declaration	Refer RSS 102	Complies
	RSP 100 RSS GEN 7.1.5	User Manual	Statement in documents provided to the user	Statement required regarding non-interference	
	RSP 100 RSS GEN 7.1.5	User Manual	No detachable antenna	Statement required regarding detachable antenna	
	RSP 100 RSS GEN 4.4.1	99% Bandwidth	203 kHz	Information only	N/A

MEASUREMENT UNCERTAINTIES

ISO/IEC 17025 requires that an estimate of the measurement uncertainties associated with the emissions test results be included in the report. The measurement uncertainties given below are based on a 95% confidence level and were calculated in accordance with UKAS document LAB 34.

Measurement Type	Frequency Range (MHz)	Calculated Uncertainty (dB)
Conducted Emissions	0.15 to 30	± 2.4
Radiated Emissions	0.015 to 30	± 3.0
Radiated Emissions	30 to 1000	± 3.6
Radiated Emissions	1000 to 40000	± 6.0

EQUIPMENT UNDER TEST (EUT) DETAILS**GENERAL**

The Savi Technology, Inc. ST-654 series devices are RFID Tags designed to identify the container to which they are attached to the Savi system. Normally, the EUT would be mounted to a container or similar piece of equipment. The EUT was treated as tabletop equipment during testing to simulate the end user environment. The EUT is battery operated.

A response from the EUT is initiated by a 123 kHz signal from a Savi SignPost or 433.92 MHz signal from a Savi Reader. Upon receiving the initiation signal the EUT transmits a signal at 433.92 MHz. This signal is comprised of SignPost ID and Tag ID. A response from the EUT is initiated by a 433.92 MHz Savi Reader signal. Upon receiving the initiation signal the EUT transmits a signal at 433.92 MHz. This signal is comprised of Tag ID. Refer to the operation description for description of the types of transmissions.

The sample was received on November 21, 2008 and tested on November 21 and November 24, 2008. The EUT consisted of the following component(s):

Company	Model	Description	Serial Number	FCC ID
Savi Technology	ST-654-031	Tag	004	KL7-654T-V3

OTHER EUT DETAILS

The EUT transmits at 433.92 MHz using FSK modulated pulses. The antenna is integral to the device. The models ST-654-031 and ST-654-031-NSN are identical except for the model number used for marketing purposes.

There are 2 other variants of this product (ST-618 and ST-621 series). The ST-654-031 represents the most configured version of the tag and was considered to be the worst-case of the three series products with respect to EMC performance. All tests were performed on a sample of the ST-654-031 and the results are considered to represent the worst case of all 3 products.

The ST-618-030, ST-618-032 and ST-618-032-NSN are same as ST-654-031 and ST-654-031-NSN except that the USB Port is not provided. Models ST-618-032 and ST-618-032-NSN are provided with an additional label which contains customer specific information. The ST-621-030, ST-621-032 and ST-621-032-NSN are same as ST-654-031 and ST-654-031-NSN except for the 2K Database Memory and USB Port is not provided. Models ST-621-032 and ST-621-032-NSN are provided with an additional label which contains customer specific information.

ANTENNA SYSTEM

The antenna is integral to the device, thereby meeting the requirements of FCC 15.203.

ENCLOSURE

The EUT enclosure is primarily constructed injection-molded plastic. It measures approximately 16.0cm wide by 5.4cm deep by 3.0cm high.

MODIFICATIONS

No modifications were made to the EUT during the time the product was at Elliott.

SUPPORT EQUIPMENT

No support equipment was used during emissions testing.

EUT INTERFACE PORTS

The I/O cabling configuration during emissions testing was as follows:

Port	Connected To	Cable(s)		
		Description	Shielded or Unshielded	Length(m)
None	-	-	-	-

The USB port is for configuration purposes only.

EUT OPERATION

The transmitter was continuously transmitting a modulated signal during radiated emissions tests. For receive mode tests the EUT was in receive mode with the LO and receiver circuit active.

TEST SITE**GENERAL INFORMATION**

Final test measurements were taken on November 21 and November 24, 2008 at the test sites listed below. Pursuant to section 2.948 of the FCC's Rules and section 3.3 of RSP-100, construction, calibration, and equipment data has been filed with the Commission and with industry Canada.

Site	Registration Numbers		Location
	FCC	Canada	
SVOATS #2	90593	2845A-2	684 West Maude Ave, Sunnyvale CA 94085-3518

ANSI C63.4-2003 recommends that ambient noise at the test site be at least 6 dB below the allowable limits. Ambient levels are below this requirement with the exception, on OATS sites, of predictable local TV, radio, and mobile communications traffic. The test site(s) contain separate areas for radiated and conducted emissions testing. Considerable engineering effort has been expended to ensure that the facilities conform to all pertinent requirements of ANSI C63.4-2003.

RADIATED EMISSIONS CONSIDERATIONS

The FCC has determined that radiation measurements made in a shielded enclosure are not suitable for determining levels of radiated emissions. Radiated measurements are performed in an open field environment or in a semi-anechoic chamber. The test sites are maintained free of conductive objects within the CISPR defined elliptical area incorporated in ANSI C63.4-2003 guidelines and meet the Normalized Site Attenuation (NSA) requirements of ANSI C63.4-2003.

MEASUREMENT INSTRUMENTATION

RECEIVER SYSTEM

An EMI receiver as specified in CISPR 16-1-1 is used for emissions measurements. The receivers used can measure over the frequency range of 9 kHz up to 2000 MHz. These receivers allow both ease of measurement and high accuracy to be achieved. The receivers have Peak, Average, and CISPR (Quasi-peak) detectors built into their design so no external adapters are necessary. The receiver automatically sets the required bandwidth for the CISPR detector used during measurements. If the repetition frequency of the signal being measured is below 20Hz, peak measurements are made in lieu of Quasi-Peak measurements.

For measurements above the frequency range of the receivers, a spectrum analyzer is utilized because it provides visibility of the entire spectrum along with the precision and versatility required to support engineering analysis. Average measurements above 1000MHz are performed on the spectrum analyzer using the linear-average method with a resolution bandwidth of 1 MHz and a video bandwidth of 10 Hz, unless the signal is pulsed in which case the average (or video) bandwidth of the measuring instrument is reduced to onset of pulse desensitization and then increased.

INSTRUMENT CONTROL COMPUTER

The receivers utilize either a Rohde & Schwarz EZM Spectrum Monitor/Controller or contain an internal Spectrum Monitor/Controller to view and convert the receiver measurements to the field strength at an antenna or voltage developed at the LISN measurement port, which is then compared directly with the appropriate specification limit. This provides faster, more accurate readings by performing the conversions described under Sample Calculations within the Test Procedures section of this report. Results are printed in a graphic and/or tabular format, as appropriate. A personal computer is used to record all measurements made with the receivers.

The Spectrum Monitor provides a visual display of the signal being measured. In addition, the controller or a personal computer run automated data collection programs which control the receivers. This provides added accuracy since all site correction factors, such as cable loss and antenna factors are added automatically.

LINE IMPEDANCE STABILIZATION NETWORK (LISN)

Line conducted measurements utilize a fifty microhenry Line Impedance Stabilization Network as the monitoring point. The LISN used also contains a 250 uH CISPR adapter. This network provides for calibrated radio frequency noise measurements by the design of the internal low pass and high pass filters on the EUT and measurement ports, respectively.

FILTERS/ATTENUATORS

External filters and precision attenuators are often connected between the receiving antenna or LISN and the receiver. This eliminates saturation effects and non-linear operation due to high amplitude transient events.

ANTENNAS

A loop antenna is used below 30 MHz. For the measurement range 30 MHz to 1000 MHz either a combination of a biconical antenna and a log periodic or a bi-log antenna is used. Above 1000 MHz, horn antennas are used. The antenna calibration factors to convert the received voltage to an electric field strength are included with appropriate cable loss and amplifier gain factors to determine an overall site factor, which is then programmed into the test receivers or incorporated into the test software.

ANTENNA MAST AND EQUIPMENT TURNTABLE

The antennas used to measure the radiated electric field strength are mounted on a non-conductive antenna mast equipped with a motor-drive to vary the antenna height. Measurements below 30 MHz are made with the loop antenna at a fixed height of 1m above the ground plane.

ANSI C63.4-2003 specifies that the test height above ground for table mounted devices shall be 80 centimeters. Floor mounted equipment shall be placed on the ground plane if the device is normally used on a conductive floor or separated from the ground plane by insulating material from 3 to 12 mm if the device is normally used on a non-conductive floor. During radiated measurements, the EUT is positioned on a motorized turntable in conformance with this requirement.

INSTRUMENT CALIBRATION

All test equipment is regularly checked to ensure that performance is maintained in accordance with the manufacturer's specifications. All antennas are calibrated at regular intervals with respect to tuned half-wave dipoles. An exhibit of this report contains the list of test equipment used and calibration information.

TEST PROCEDURES**EUT AND CABLE PLACEMENT**

The regulations require that interconnecting cables be connected to the available ports of the unit and that the placement of the unit and the attached cables simulate the worst case orientation that can be expected from a typical installation, so far as practicable. To this end, the position of the unit and associated cabling is varied within the guidelines of ANSI C63.4-2003, and the worst-case orientation is used for final measurements.

RADIATED EMISSIONS

A preliminary scan of the radiated emissions is performed in which all significant EUT frequencies are identified with the system in a nominal configuration. At least two scans are performed, one scan for each antenna polarization (horizontal and vertical; loop parallel and perpendicular to the EUT). During the preliminary scans, the EUT is rotated through 360°, the antenna height is varied (for measurements above 30 MHz) and cable positions are varied to determine the highest emission relative to the limit. Preliminary scans may be performed in a fully anechoic chamber for the purposes of identifying the frequencies of the highest emissions from the EUT.

A speaker is provided in the receiver to aid in discriminating between EUT and ambient emissions. Other methods used during the preliminary scan for EUT emissions involve scanning with near field magnetic loops, monitoring I/O cables with RF current clamps, and cycling power to the EUT.

Final maximization is a phase in which the highest amplitude emissions identified in the spectral search are viewed while the EUT azimuth angle is varied from 0 to 360 degrees relative to the receiving antenna. The azimuth, which results in the highest emission is then maintained while varying the antenna height from one to four meters (for measurements above 30 MHz, measurements below 30 MHz are made with the loop antenna at a fixed height of 1m). The result is the identification of the highest amplitude for each of the highest peaks. Each recorded level is corrected in the receiver using appropriate factors for cables, connectors, antennas, and preamplifier gain.

When testing above 18 GHz, the receive antenna is located at 1 meter from the EUT and the antenna height is restricted to a maximum of 2.5 meters.

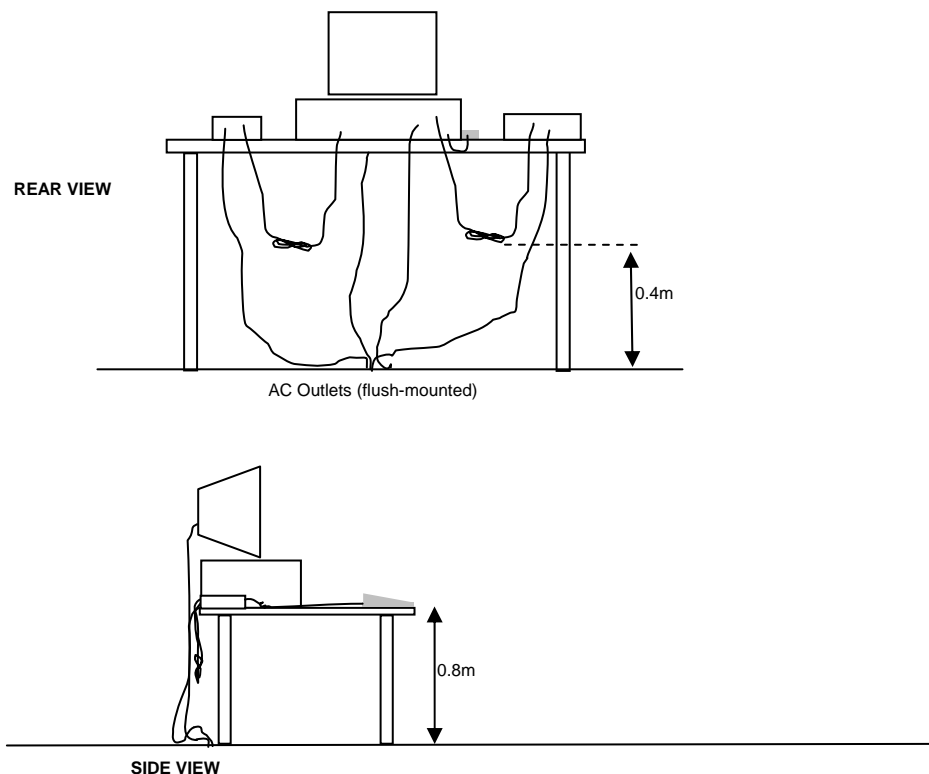

Typical Test Configuration for Radiated Field Strength Measurements

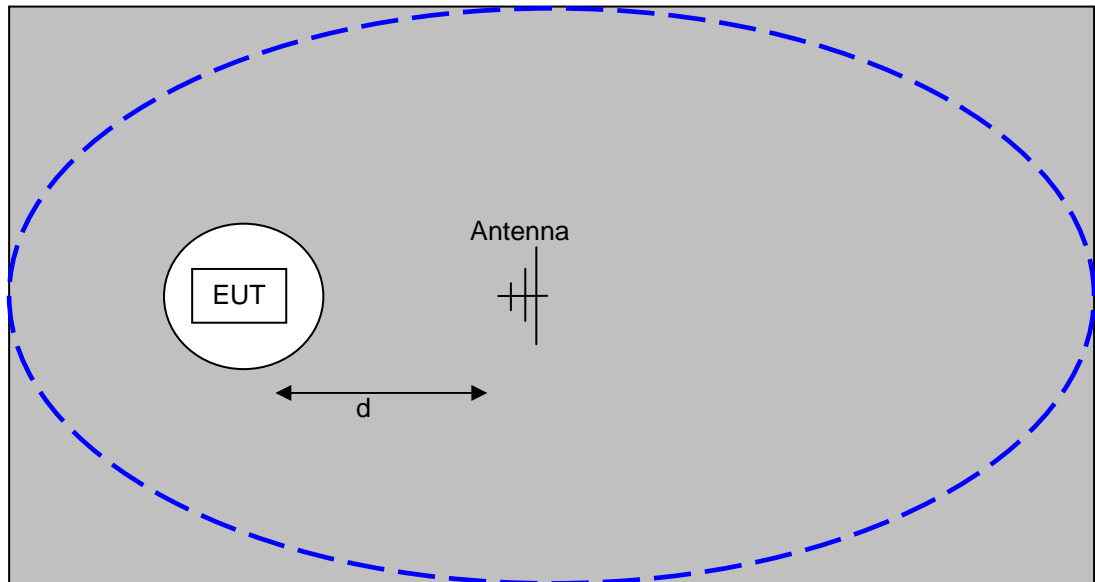

The ground plane extends beyond the ellipse defined in CISPR 16 / CISPR 22 / ANSI C63.4 and is large enough to accommodate test distances (d) of 3m and 10m. Refer to the test data tables for the actual measurement distance.

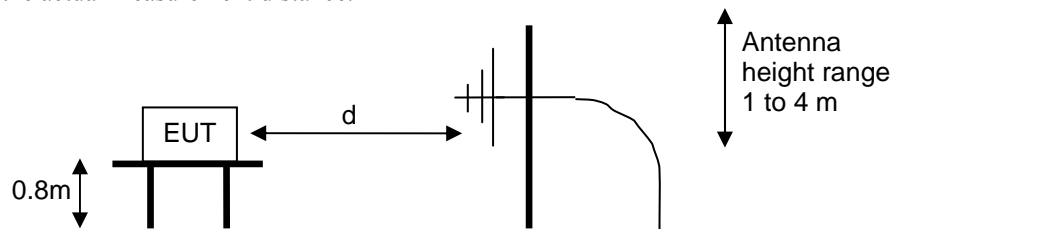

Test Configuration for Radiated Field Strength Measurements
OATS- Plan and Side Views

BANDWIDTH MEASUREMENTS

The 6dB, 20dB and/or 26dB signal bandwidth is measured in using the bandwidths recommended by ANSI C63.4. When required, the 99% bandwidth is measured using the methods detailed in RSS GEN.

SPECIFICATION LIMITS AND SAMPLE CALCULATIONS

The limits for conducted emissions are given in units of microvolts, and the limits for radiated emissions are given in units of microvolts per meter at a specified test distance. Data is measured in the logarithmic form of decibels relative to one microvolt, or dB microvolts (dBuV). For radiated emissions, the measured data is converted to the field strength at the antenna in dB microvolts per meter (dBuV/m). The results are then converted to the linear forms of uV and uV/m for comparison to published specifications.

For reference, converting the specification limits from linear to decibel form is accomplished by taking the base ten logarithm, then multiplying by 20. These limits in both linear and logarithmic form are as follows:

GENERAL TRANSMITTER RADIATED EMISSIONS SPECIFICATION LIMITS

The table below shows the limits for the spurious emissions from transmitters that fall in restricted bands¹ (with the exception of transmitters operating under FCC Part 15 Subpart D and RSS 210 Annex 9), the limits for all emissions from a low power device operating under the general rules of RSS 310 (tables 3 and 4), RSS 210 (table 2) and FCC Part 15 Subpart C section 15.209.

Frequency Range (MHz)	Limit (uV/m)	Limit (dBuV/m @ 3m)
0.009-0.490	$2400/F_{\text{KHz}} @ 300\text{m}$	$67.6-20*\log_{10}(F_{\text{KHz}}) @ 300\text{m}$
0.490-1.705	$24000/F_{\text{KHz}} @ 30\text{m}$	$87.6-20*\log_{10}(F_{\text{KHz}}) @ 30\text{m}$
1.705 to 30	30 @ 30m	29.5 @ 30m
30 to 88	100 @ 3m	40 @ 3m
88 to 216	150 @ 3m	43.5 @ 3m
216 to 960	200 @ 3m	46.0 @ 3m
Above 960	500 @ 3m	54.0 @ 3m

¹ The restricted bands are detailed in FCC 15.203, RSS 210 Table 1 and RSS 310 Table 2

SAMPLE CALCULATIONS - RADIATED EMISSIONS

Receiver readings are compared directly to the specification limit (decibel form). The receiver internally corrects for cable loss, preamplifier gain, and antenna factor. The calculations are in the reverse direction of the actual signal flow, thus cable loss is added and the amplifier gain is subtracted. The Antenna Factor converts the voltage at the antenna coaxial connector to the field strength at the antenna elements.

A distance factor, when used for electric field measurements above 30MHz, is calculated by using the following formula:

$$F_d = 20 * \text{LOG}_{10} (D_m/D_s)$$

where:

$$F_d = \text{Distance Factor in dB}$$

$$D_m = \text{Measurement Distance in meters}$$

$$D_s = \text{Specification Distance in meters}$$

For electric field measurements below 30MHz the extrapolation factor is either determined by making measurements at multiple distances or a theoretical value is calculated using the formula:

$$F_d = 40 * \text{LOG}_{10} (D_m/D_s)$$

Measurement Distance is the distance at which the measurements were taken and Specification Distance is the distance at which the specification limits are based. The antenna factor converts the voltage at the antenna coaxial connector to the field strength at the antenna elements.

The margin of a given emission peak relative to the limit is calculated as follows:

$$R_c = R_r + F_d$$

and

$$M = R_c - L_s$$

where:

$$R_r = \text{Receiver Reading in dBuV/m}$$

$$F_d = \text{Distance Factor in dB}$$

$$R_c = \text{Corrected Reading in dBuV/m}$$

$$L_s = \text{Specification Limit in dBuV/m}$$

$$M = \text{Margin in dB Relative to Spec}$$

SAMPLE CALCULATIONS - FIELD STRENGTH TO EIRP CONVERSION

Where the radiated electric field strength is expressed in terms of the equivalent isotropic radiated power (eirp), or where a field strength measurement of output power is made in lieu of a direct measurement, the following formula is used to convert between eirp and field strength at a distance of 3m from the equipment under test:

$$E = \frac{1000000 \sqrt{30 P}}{3} \text{ microvolts per meter}$$

where P is the eirp (Watts)

EXHIBIT 1: Test Equipment Calibration Data

1 Page

Radiated Emissions, 30 - 4,400 MHz, 21-25 of Nov 2008

Engineer: Mehran Birgani

<u>Manufacturer</u>	<u>Description</u>	<u>Model #</u>	<u>Asset #</u>	<u>Cal Due</u>
Elliott Laboratories	Biconical Antenna, 30-300 MHz	EL30.300	54	26-Mar-09
Elliott Laboratories	Log Periodic Antenna 300-1000 MHz	EL300.1000	55	27-Feb-09
Hewlett Packard	EMC Spectrum Analyzer, 9 kHz - 6.5 GHz	8595EM	780	09-Dec-08
Hewlett Packard	Microwave Preamplifier, 1-26.5GHz	8449B	870	09-Oct-09
Filtek	Filter, 1 GHz High Pass	HP12/1000-5BA	956	30-Jul-09
Rohde & Schwarz	Test Receiver, 0.009-2750 MHz	ESN	1332	29-Jan-09
EMCO	Antenna, Horn, 1-18 GHz	3115	1561	10-Jun-10

EXHIBIT 2: Test Measurement Data

8 Pages

Client:	Savi	Job Number:	J73783
Model:	ST-654-031	T-Log Number:	T73823
		Account Manager:	Sherren Washington
Contact:	Eugene Schlindwein	Project Engineer:	David Bear
Emissions Spec:	FCC 15.231(a/e); FCC 15.240	Class:	A
Immunity Spec:	-	Environment:	-

EMC Test Data

For The

Savi

Model

ST-654-031

Date of Last Test: 1/5/2009

Client:	Savi	Job Number:	J73783
Model:	ST-654-031	T-Log Number:	T73823
		Account Manager:	Sherren Washington
Contact:	Eugene Schlindwein		
Emissions Spec:	FCC 15.231(a/e); FCC 15.240	Class:	A
Immunity Spec:	-	Environment:	-

EUT INFORMATION

General Description

The EUT is an RF Tagging device which is designed to identify the container to which it is attached to the Savi System. Normally, the EUT would be mounted to a container or similar piece of equipment. The EUT was treated as table-top equipment during testing to simulate the end user environment. The EUT is battery operated.

Equipment Under Test

Manufacturer	Model	Description	Serial Number	FCC ID
Savi Technology	ST-654-031	Tag	004	KL7-654T-V3

Other EUT Details

A response from the EUT is initiated by a 123 kHz signal from a Savi SignPost or 433.92 MHz signal from a Savi Reader. Upon receiving the initiation signal the EUT transmits a signal at 433.92 MHz. This signal is comprised of SignPost ID and Tag ID. A response from the EUT is initiated by a 433.92 MHz Savi Reader signal. Upon receiving the initiation signal the EUT transmits a signal at 433.92 MHz. This signal is comprised of Tag ID. Refer to the operation description for description of the types of transmissions.

There are 2 other variants of this product (ST-618 and ST-621 series). The ST-654-031 represents the most configured version of the tag and was considered to be the worst-case of the three series products with respect to EMC performance. All tests were performed on a sample of the ST-654-031 and the results are considered to represent the worst case of all 3 products.

The ST-618-030, ST-618-032 and ST-618-032-NSN are same as ST-654-031 and ST-654-031-NSN except that the USB Port is not provided. Models ST-618-032 and ST-618-032-NSN are provided with an additional label which contains customer specific information. The ST-621-030, ST-621-032 and ST-621-032-NSN are same as ST-654-031 and ST-654-031-NSN except for the 2K Database Memory and USB Port is not provided. Models ST-621-032 and ST-621-032-NSN are provided with an additional label which contains customer specific information.

The antenna is integral to the device, thereby meeting the requirements of FCC 15.203.

EUT Enclosure

The EUT enclosure is primarily constructed of plastic and is provided with a plastic mounting bracket. It measures approximately 6.5 cm wide by 3.5 cm deep by 15.5 cm high.

Modification History

Mod. #	Test	Date	Modification
1	-	-	None

Modifications applied are assumed to be used on subsequent tests unless otherwise stated as a further modification.

Client:	Savi	Job Number:	J73783
Model:	ST-654-031	T-Log Number:	T73823
		Account Manager:	Sherren Washington
Contact:	Eugene Schlindwein		
Emissions Spec:	FCC 15.231(a/e); FCC 15.240	Class:	A
Immunity Spec:	-	Environment:	-

Test Configuration #1

Local Support Equipment

Manufacturer	Model	Description	Serial Number	FCC ID
None	-	-	-	-

Remote Support Equipment

Manufacturer	Model	Description	Serial Number	FCC ID
None	-	-	-	-

Interface Cabling and Ports

Port	Connected To	Cable(s)		
		Description	Shielded or Unshielded	Length(m)
None	-	-	-	-

The USB port is for configuration only. It may be connected for some tests.

EUT Operation During Emissions Tests

The transmitter was continuously transmitting a modulated signal during emissions tests. For receive mode and digital circuit tests the EUT was in receive mode with the LO and receiver circuit active.

Client:	Savi	Job Number:	J73783
Model:	ST-654-031	T-Log Number:	T73823
		Account Manager:	Sherren Washington
Contact:	Eugene Schlindwein		
Spec:	FCC 15.231(a/e); FCC 15.240	Class:	A

Radiated Emissions

Test Specifics

Objective: The objective of this test session is to perform final qualification testing of the EUT with respect to the specification listed above.

General Test Configuration

The EUT was located on the turntable for radiated emissions testing.

Note, **preliminary** testing indicates that the emissions were maximized by orientation of the EUT and elevation of the measurement antenna. **Maximized** testing indicated that the emissions were maximized by orientation of the EUT, elevation of the measurement antenna, and manipulation of the EUT's interface cables.

Note, for testing above 1 GHz, the FCC specifies the limit as an average measurement. In addition, the FCC states that the peak reading of any emission above 1 GHz, can not exceed the average limit by more than 20 dB.

Ambient Conditions:

Temperature (°C):	17-25
Rel. Humidity (%):	30-55

Modifications Made During Testing:

Special software is loaded into the device prior to testing to allow continuous transmission for ease of testing.

Deviations From The Standard

No deviations were made from the requirements of the standard.

Summary of Results

Run #	Test Performed	Limit	Result	Margin
1a	RE, 433.92MHz, Fundamental	15.231(e) / RSS 210	Pass	71.7dB μ V/m (3845.9 μ V/m) @ 433.91MHz (-1.2dB)
1a	RE, 433.92MHz, Fundamental	15.231(a) / RSS 210	Pass	79.7dB μ V/m (9660.5 μ V/m) @ 433.91MHz (-1.1dB)
1a	RE, 433.92MHz, Fundamental	15.240 / RSS-210	Pass	79.7dB μ V/m (9660.5 μ V/m) @ 433.91MHz (-1.1dB)
1b	RE, Tx Spurious Emissions	FCC 15.209	Pass	45.1dB μ V/m (179.9 μ V/m) @ 867.83MHz (-0.9dB)
2	RE, Rx Spurious Emissions	15.109 & RSS-GEN	Pass	41.0dB μ V/m (112.2 μ V/m) @ 1268.4MHz (-13.0dB)
3	Bandwidth (20dB)	15.231 / RSS 210	Pass	458 kHz
3	Bandwidth (99%)	RSS-GEN	N/A	203 kHz

Client: Savi	Job Number: J73783
Model: ST-654-031	T-Log Number: T73823
	Account Manager: Sherren Washington
Contact: Eugene Schlindwein	
Spec: FCC 15.231(a/e); FCC 15.240	Class: A

Run #1: Radiated Emissions, 30 MHz - 4.3 GHz

Date of Test: 11/21/2008 Config. Used: 1
 Test Engineer: Mehran Birgani Config Change: None
 Test Location: SVOATS #2 EUT Voltage: Battery

Run #1a: Fundamental Measurement of 433.923

Operation under 15.231(e)

Frequency MHz	Level dB μ V/m	Pol V/H	FCC 15.231(e)		Detector Pk/QP/Avg	Azimuth degrees	Height meters	Comments
			Limit	Margin				
433.912	71.7	V	72.9	-1.2	AVG	351	1.2	Upright
433.912	71.6	H	72.9	-1.3	AVG	274	1.0	Side
433.912	64.0	H	72.9	-8.9	AVG	270	1.0	Upright
433.912	58.1	V	72.9	-14.8	AVG	247	1.0	Side
433.915	70.2	H	72.9	-2.7	AVG	273	1.0	Flat
433.917	69.8	V	72.9	-3.1	AVG	360	1.2	Flat
433.912	91.7	V	92.9	-1.2	PK	351	1.2	Upright
433.912	91.6	H	92.9	-1.3	PK	274	1.0	Side
433.912	84.0	H	92.9	-8.9	PK	270	1.0	Upright
433.912	78.1	V	92.9	-14.8	PK	247	1.0	Side
433.915	90.2	H	92.9	-2.7	PK	273	1.0	Flat
433.917	89.8	V	92.9	-3.1	PK	360	1.2	Flat

Note 1: Duty cycle is 10% . A -20dB correction was used to determine the average level from the peak reading

Operation under 15.231(a)

Frequency MHz	Level dB μ V/m	Pol V/H	FCC 15.231(a)		Detector Pk/QP/Avg	Azimuth degrees	Height meters	Comments
			Limit	Margin				
433.912	79.7	V	80.8	-1.1	AVG	351	1.2	Upright
433.912	91.7	V	100.8	-9.1	PK	351	1.2	Upright

Note 1: Duty cycle is 25% . A -12dB correction was used to determine the average level from the peak reading

Note 2: Peak readings made using a receiver and measurement bandwidth set to 120kHz.

Operation under 15.240

Frequency MHz	Level dB μ V/m	Pol V/H	FCC 15.240		Detector Pk/QP/Avg	Azimuth degrees	Height meters	Comments
			Limit	Margin				
433.912	79.7	V	80.8	-1.1	AVG	351	1.2	Upright
433.912	91.7	V	94.8	-3.1	PK	351	1.2	Upright

Note 1: Duty cycle is 25% . A -12dB correction was used to determine the average level from the peak reading

Note 2: Peak readings made using a receiver and measurement bandwidth set to 120kHz.

Client: Savi	Job Number: J73783
Model: ST-654-031	T-Log Number: T73823
	Account Manager: Sherren Washington
Contact: Eugene Schlindwein	
Spec: FCC 15.231(a/e); FCC 15.240	Class: A

Run #1b: Spurious Emissions, 30-4400 MHz (Tx Mode)

Frequency MHz	Level dB μ V/m	Pol v/h	FCC 15.209		Detector Pk/QP/Avg	Azimuth degrees	Height meters	Comments
			Limit	Margin				
1301.590	32.4	V	54.0	-21.6	AVG	360	3.1	Side
1301.640	32.4	H	54.0	-21.6	AVG	233	1.5	Upright
1301.670	34.5	H	54.0	-19.5	AVG	293	1.0	Flat
1301.700	36.0	V	54.0	-18.0	AVG	255	1.7	Upright
1301.760	34.4	V	54.0	-19.6	AVG	325	1.0	Flat
1301.780	36.7	H	54.0	-17.3	AVG	69	3.2	Side
1735.530	35.4	H	54.0	-18.6	AVG	113	3.0	Side, Note 2
1735.590	36.0	V	54.0	-18.0	AVG	272	2.3	Upright, Note 2
1735.650	35.0	H	54.0	-19.0	AVG	337	2.2	Upright, Note 2
1735.720	33.9	V	54.0	-20.1	AVG	181	1.3	Side, Note 2
1735.740	34.2	V	54.0	-19.8	AVG	185	1.0	Flat, Note 2
1735.760	33.5	H	54.0	-20.5	AVG	229	2.8	Flat, Note 2
1301.590	44.4	V	74.0	-29.6	PK	360	3.1	Side
1301.640	44.4	H	74.0	-29.6	PK	233	1.5	Upright
1301.670	46.5	H	74.0	-27.5	PK	293	1.0	Flat
1301.700	48.0	V	74.0	-26.0	PK	255	1.7	Upright
1301.760	46.4	V	74.0	-27.6	PK	325	1.0	Flat
1301.780	48.7	H	74.0	-25.3	PK	69	3.2	Side
1735.530	47.4	H	74.0	-26.6	PK	113	3.0	Side, Note 2
1735.590	48.0	V	74.0	-26.0	PK	272	2.3	Upright, Note 2
1735.650	47.0	H	74.0	-27.0	PK	337	2.2	Upright, Note 2
1735.720	45.9	V	74.0	-28.1	PK	181	1.3	Side, Note 2
1735.740	46.2	V	74.0	-27.8	PK	185	1.0	Flat, Note 2
1735.760	45.5	H	74.0	-28.5	PK	229	2.8	Flat, Note 2
867.832	45.1	V	46.0	-0.9	QP	347	3.2	Side
867.832	43.6	V	46.0	-2.4	QP	234	2.1	Upright
867.832	40.0	H	46.0	-6.0	QP	254	2.9	Side
867.832	39.1	H	46.0	-6.9	QP	50	1.0	Flat
867.832	35.8	V	46.0	-10.2	QP	356	1.0	Flat
867.832	31.3	H	46.0	-14.7	QP	178	1.0	Upright

Note 1:	Worst case duty cycle for all three operational modes is 25% . A -12dB correction was used to determine the average level from the peak reading. All three orientations evaluated and all readings within 20dB of the limit were recorded.
Note 2:	Signal is not in a restricted band but the more stringent restricted band limit was used.
Note 3:	All harmonics were measured; however, the signals that were more than 20dB below the limit or were within the noise floor were not recorded.

Client: Savi	Job Number: J73783
Model: ST-654-031	T-Log Number: T73823
Contact: Eugene Schlindwein	Account Manager: Sherren Washington
Spec: FCC 15.231(a/e); FCC 15.240	Class: A

Run #3: Transmit Mode (433.92 MHz) - Bandwidth

Date of Test: 11/24/2008
 Test Engineer: Mehran Birgani
 Test Location: SVOATS #2

Config. Used: 1
 Config Change: None
 EUT Voltage: Battery

Signal bandwidth was measured to be 458 kHz (see graph below - RB=VB=100kHz). The maximum permitted bandwidth is 0.25% of the fundamental signal level = 1.08MHz

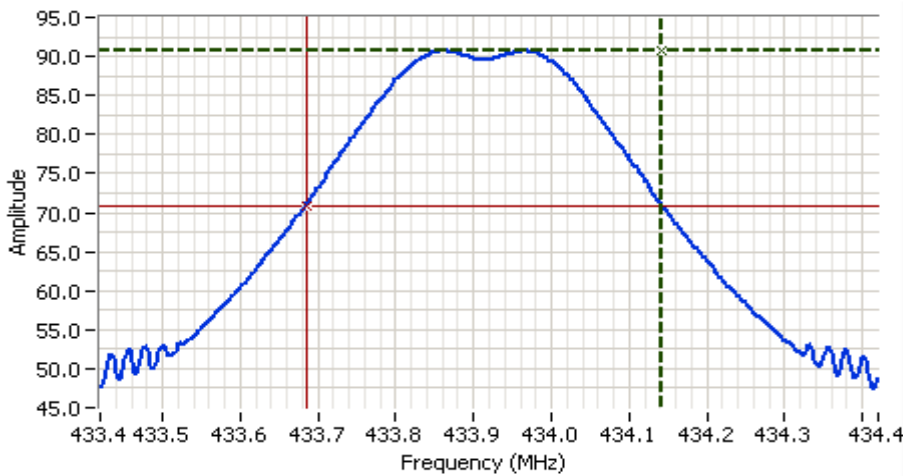

Analyzer Settings
 HP8595EM
 CF: 433.920 MHz
 SPAN: 1.000 MHz
 RB 100 kHz
 VB 30.0 kHz
 Detector POS
 Att 10
 RL Offset 0.00
 Sweep Time 20.0ms
 Ref Lvl: 100.00DBUV

Comments
 20dB BW: 458 kHz

Cursor 1 434.1425 90.72  Delta Freq. 458 kHz
 Cursor 2 433.6850 70.72  Delta Amplitude 20.00

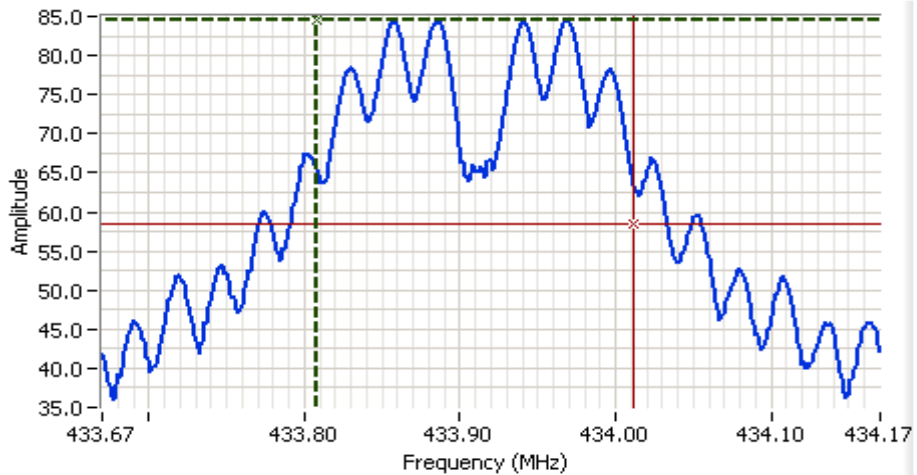

Analyzer Settings
 HP8595EM
 CF: 433.920 MHz
 SPAN: 500 kHz
 RB 10.00 kHz
 VB 30.0 kHz
 Detector POS
 Att 10
 RL Offset 0.00
 Sweep Time 30.0ms
 Ref Lvl: 91.00DBUV

Comments
 99% BW: 203 kHz

Cursor 1 433.8084 84.54  Delta Freq. 203 kHz
 Cursor 2 434.0117 58.54  Delta Amplitude 26.00



EXHIBIT 3: Photographs of Test Configurations

EXHIBIT 4: Proposed FCC ID Label & Label Location

***EXHIBIT 5: Detailed Photographs
of Savi Technology, Inc. Model ST-654-031 Construction***

Pages

***EXHIBIT 6: Operator's Manual
for Savi Technology, Inc. Model ST-654-031***

Pages

***EXHIBIT 7: Block Diagram
of Savi Technology, Inc. Model ST-654-031***

Pages

***EXHIBIT 8: Schematic Diagrams
for Savi Technology, Inc. Model ST-654-031***

Pages

***EXHIBIT 9: Theory of Operation
for Savi Technology, Inc. Model ST-654-031***

Pages

EXHIBIT 10: Advertising Literature

Pages

EXHIBIT 11: RF Exposure Information

Pages