

Electromagnetic Emissions Test Report

*Application for Grant of Equipment Authorization
pursuant to
Industry Canada RSS-Gen Issue 2 / RSS 210 Issue 7
FCC Part 15 Subpart C (15.240)
on the
Savi Technology, Inc.
Transmitter
Models: SR-650-101 and SR-650-101-CA*

UPN: 2404A-650R1
FCC ID: KL7-650R-V2

GRANTEE: Savi Technology, Inc.
351 E. Evelyn Ave.
Mountain View, CA 94041

TEST SITE: Elliott Laboratories
684 W. Maude Ave
Sunnyvale, CA 94086

REPORT DATE: July 30, 2008

FINAL TEST DATE: June 10, June 11 and June 25, 2008

AUTHORIZED SIGNATORY:



David W. Bare
Chief Engineer



Testing Cert #2016-01

Elliott Laboratories is accredited by the A2LA, certificate number 2016-01, to perform the test(s) listed in this report. This report shall not be reproduced, except in its entirety, without the written approval of Elliott Laboratories

REVISION HISTORY

Rev #	Date	Comments	Modified By
1	September 19, 2008	Initial Release	David Guidotti

TABLE OF CONTENTS

COVER PAGE.....1

REVISION HISTORY2

TABLE OF CONTENTS3

SCOPE.....5

OBJECTIVE5

STATEMENT OF COMPLIANCE.....6

TEST RESULTS SUMMARY6

 RFID DEVICES OPERATING IN THE 433.5 – 434.5MHZ BANDS.....6

MEASUREMENT UNCERTAINTIES.....7

EQUIPMENT UNDER TEST (EUT) DETAILS.....8

 GENERAL.....8

 OTHER EUT DETAILS.....8

 ANTENNA SYSTEM.....8

 ENCLOSURE.....8

 MODIFICATIONS.....8

 SUPPORT EQUIPMENT.....9

 EUT INTERFACE PORTS.....9

 EUT OPERATION.....9

TEST SITE.....10

 GENERAL INFORMATION.....10

 CONDUCTED EMISSIONS CONSIDERATIONS.....10

 RADIATED EMISSIONS CONSIDERATIONS.....10

MEASUREMENT INSTRUMENTATION.....11

 RECEIVER SYSTEM.....11

 INSTRUMENT CONTROL COMPUTER.....11

 LINE IMPEDANCE STABILIZATION NETWORK (LISN).....11

 FILTERS/ATTENUATORS.....12

 ANTENNAS.....12

 ANTENNA MAST AND EQUIPMENT TURNTABLE.....12

 INSTRUMENT CALIBRATION.....12

TEST PROCEDURES13

 EUT AND CABLE PLACEMENT.....13

 CONDUCTED EMISSIONS.....13

 RADIATED EMISSIONS.....13

 RADIATED EMISSIONS.....14

 BANDWIDTH MEASUREMENTS.....16

 SPECIFICATION LIMITS AND SAMPLE CALCULATIONS.....17

 GENERAL TRANSMITTER RADIATED EMISSIONS SPECIFICATION LIMITS.....17

 SAMPLE CALCULATIONS - CONDUCTED EMISSIONS.....18

 SAMPLE CALCULATIONS - RADIATED EMISSIONS.....18

 SAMPLE CALCULATIONS - FIELD STRENGTH TO EIRP CONVERSION.....19

TABLE OF CONTENTS (Continued)

EXHIBIT 1: Test Equipment Calibration Data..... 1
EXHIBIT 2: Test Measurement Data..... 2
EXHIBIT 3: Photographs of Test Configurations..... 3
EXHIBIT 4: Proposed FCC ID Label & Label Location 4
EXHIBIT 5: Detailed Photographs..... 5
EXHIBIT 6: Operator's Manual 6
EXHIBIT 7: Block Diagram..... 7
EXHIBIT 8: Schematic Diagrams..... 8
EXHIBIT 9: Theory of Operation 9
EXHIBIT 10: Advertising Literature..... 10

SCOPE

An electromagnetic emissions test has been performed on the Savi Technology, Inc. model SR-650-101 pursuant to the following rules:

Industry Canada RSS-Gen Issue 2
RSS 210 Issue 7 "Low-power Licence-exempt Radiocommunication Devices (All Frequency Bands): Category I Equipment"
FCC Part 15 Subpart C

Conducted and radiated emissions data has been collected, reduced, and analyzed within this report in accordance with measurement guidelines set forth in the following reference standards and as outlined in Elliott Laboratories test procedures:

ANSI C63.4:2003

The intentional radiator above has been tested in a simulated typical installation to demonstrate compliance with the relevant Industry Canada performance and procedural standards.

Final system data was gathered in a mode that tended to maximize emissions by varying orientation of EUT, orientation of power and I/O cabling, antenna search height, and antenna polarization.

Every practical effort was made to perform an impartial test using appropriate test equipment of known calibration. All pertinent factors have been applied to reach the determination of compliance.

The test results recorded herein are based on a single type test of the Savi Technology, Inc. model SR-650-101 and therefore apply only to the tested sample. The sample was selected and prepared by Eugene Schlindwein of Savi Technology, Inc. The sample tested was considered representative of the model SR-650-101-CA as this is identical to the model SR-650-101 except for the model number.

OBJECTIVE

The primary objective of the manufacturer is compliance with the regulations outlined in the previous section.

Certification is a procedure where the manufacturer submits test data and technical information to a certification body and receives a certificate or grant of equipment authorization upon successful completion of the certification body's review of the submitted documents. Once the equipment authorization has been obtained, the label indicating compliance must be attached to all identical units, which are subsequently manufactured.

Maintenance of compliance is the responsibility of the manufacturer. Any modification of the product which may result in increased emissions should be checked to ensure compliance has been maintained (i.e., printed circuit board layout changes, different line filter, different power supply, harnessing or I/O cable changes, etc.).

STATEMENT OF COMPLIANCE

The tested sample of Savi Technology, Inc. model SR-650-101 complied with the requirements of the following regulations:

Industry Canada RSS-Gen Issue 2
RSS 210 Issue 7 “Low-power Licence-exempt Radiocommunication Devices (All Frequency Bands): Category I Equipment”
FCC Part 15 Subpart C

Maintenance of compliance is the responsibility of the manufacturer. Any modification of the product which may result in increased emissions should be checked to ensure compliance has been maintained (i.e., printed circuit board layout changes, different line filter, different power supply, harnessing or I/O cable changes, etc.).

TEST RESULTS SUMMARY

RFID DEVICES OPERATING IN THE 433.5 – 434.5MHz BANDS

FCC Rule Part	RSS Rule Part	Description	Measured Value / Comments	Limit / Requirement	Result
15.240 (a)	RSS 210 A5	Location of operation	Refer to user manual (p 3 and 4)	Must be limited to commercial and industrial areas	Complies
15.240 (f)	-	Information to user		Notification of geographic limitations	Complies
15.240 (b)	RSS 210 A5 (1)	Duration of transmissions	Refer to Operational Description	< 60s with 10s silent period	Complies
15.240 (b)	RSS 210 A5 (2)	Fundamental Signal Strength	80.0dB μ V/m @ 433.916MHz (-0.8dB) Average	11000uV/m avg 55000uV/m pk	Complies
15.240 (c) / 15.209	RSS 210 Table 2	Radiated Spurious Emissions, 30 MHz – 4339 MHz	38.6dB μ V/m @ 867.831MHz (-7.4dB)	Refer to standard	Complies
15.203	-	RF Connector	No external RF connector	No external RF connector or special connector used	Complies
15.109	RSS GEN 7.2.3 Table 1	Receiver spurious emissions	33.9dB μ V @ 423.21MHz (-12.1dB)	Refer to standard	Complies
15.207	RSS GEN Table 2	AC Conducted Emissions	32.5dB μ V @ 3.506MHz (-13.5dB)	Refer to standard	
	RSP 100 RSS GEN 4.4.1	99% Bandwidth	146 kHz	Information only	N/A

MEASUREMENT UNCERTAINTIES

ISO/IEC 17025 requires that an estimate of the measurement uncertainties associated with the emissions test results be included in the report. The measurement uncertainties given below are based on a 95% confidence level and were calculated in accordance with UKAS document LAB 34.

Measurement Type	Frequency Range (MHz)	Calculated Uncertainty (dB)
Conducted Emissions	0.15 to 30	± 2.4
Radiated Emissions	0.015 to 30	± 3.0
Radiated Emissions	30 to 1000	± 3.6
Radiated Emissions	1000 to 40000	± 6.0

EQUIPMENT UNDER TEST (EUT) DETAILS

GENERAL

The Savi Technology, Inc. models SR-650-101 and SR-650-101-CA are RFID tag readers that are designed to track asset tags that use Savi's 433.92 MHz transceivers. Normally, the EUT would be pole-mounted during operation. The EUT was treated as table-top equipment during testing to simulate the end-user environment. The electrical rating of the EUT is 92-125/184-250 VAC, 50/60 Hz, 300 mA, 12-24 VDC, 500 mA.

The sample was received on June 10, 2008 and tested on June 10, June 11 and June 25, 2008. The EUT consisted of the following component(s):

Manufacturer	Model	Description	Serial Number	FCC ID
Savi Technology	SR-650-101	Fixed Reader	DEV0024-4	KL7-650R-V2

OTHER EUT DETAILS

The EUT transmits four different control commands (Wake-Up, Hello, Sleep and Search) plus control/data signals. Apart from the wake-up command that is a continuous signal, all other commands have a duty cycle that is less than 60mS in a 100ms period.

The Wake-Up signal is a continuous signal that is transmitted for 2.5 seconds on the first transmitter and then 2.5 seconds on the second transmitter. Refer to the SAVI operational description.

There are two transmitters in the reader. Each transmitter connects to a different antenna. The antennas are identical but arranged at 90 degrees to each other. All transmissions are made from one antenna or from the other to achieve an omni-directional pattern. All duty-cycles take into consideration combinations of transmissions from both antennas, that is the combination of any transmissions from transmitter number one followed by transmissions from antenna number 2 meet the requirements for timing as detailed in 15.231. Both transmitters cannot operate simultaneously.

ANTENNA SYSTEM

The antenna system used with the Savi Technology, Inc. model SR-650-101 is permanently attached to and an integral part of the system

ENCLOSURE

The EUT enclosure is primarily constructed of plastic. It has a diameter of 30 cm (12 in.) and a height of 14 cm (5.5 in.).

MODIFICATIONS

The EUT did not require modifications during testing in order to comply with emissions specifications.

SUPPORT EQUIPMENT

No local support equipment was used during emissions testing.

The following equipment was used as remote support equipment for emissions testing:

Manufacturer	Model	Description	Serial Number	FCC ID
Savi	410R	SaviReader	-	KL7-410GR-V11
IBM	2635	Laptop PC	78-VA248 97/11	-

EUT INTERFACE PORTS

The I/O cabling configuration during emissions testing was as follows:

Port	Connected To	Cable(s)		
		Description	Shielded or Unshielded	Length(m)
Ethernet	Laptop	CAT 5	Unshielded	30
Savi Net In	410R	multiwire	Unshielded	30
Savi Net thru	410R	multiwire	Unshielded	30
DC Input	DC power Supply	2 wire	Unshielded	2
AC in	AC Mains	3 wire	Unshielded	2

Note: The RS-232 port was not connected as the manufacturer stated that this is for configuration and servicing purposes and therefore would not normally be connected. Either DC power or AC power were connected, refer to test details for configuration used.

EUT OPERATION

The EUT was continuously transmitting for transmitter mode tests. For receiver/digital device tests the EUT was pinged from the laptop and operated in receive mode.

TEST SITE

GENERAL INFORMATION

Final test measurements were taken on June 10, June 11 and June 25, 2008 at the Elliott Laboratories Open Area Test Site #2 located at 684 West Maude Avenue, Sunnyvale, California. Pursuant to section 2.948 of the FCC's Rules and section 3.3 of RSP-100, construction, calibration, and equipment data has been filed with the Commission.

ANSI C63.4:2003 recommends that ambient noise at the test site be at least 6 dB below the allowable limits. Ambient levels are below this requirement with the exception of predictable local TV, radio, and mobile communications traffic. The test site contains separate areas for radiated and conducted emissions testing. Considerable engineering effort has been expended to ensure that the facilities conform to all pertinent requirements of ANSI C63.4:2003.

CONDUCTED EMISSIONS CONSIDERATIONS

Conducted emissions testing is performed in conformance with ANSI C63.4:2003. Measurements are made with the EUT connected to the public power network through a nominal, standardized RF impedance, which is provided by a line impedance stabilization network, known as a LISN. A LISN is inserted in series with each current-carrying conductor in the EUT power cord.

RADIATED EMISSIONS CONSIDERATIONS

The FCC has determined that radiation measurements made in a shielded enclosure are not suitable for determining levels of radiated emissions. Radiated measurements are performed in an open field environment or in a semi-anechoic chamber. The test sites are maintained free of conductive objects within the CISPR defined elliptical area incorporated in ANSI C63.4:2003 guidelines and meet the Normalized Site Attenuation (NSA) requirements of ANSI C63.4:2003.

MEASUREMENT INSTRUMENTATION

RECEIVER SYSTEM

An EMI receiver as specified in CISPR 16-1 is used for emissions measurements. The receivers used can measure over the frequency range of 9 kHz up to 2000 MHz. These receivers allow both ease of measurement and high accuracy to be achieved. The receivers have Peak, Average, and CISPR (Quasi-peak) detectors built into their design so no external adapters are necessary. The receiver automatically sets the required bandwidth for the CISPR detector used during measurements. If the repetition frequency of the signal being measured is below 20Hz, peak measurements are made in lieu of Quasi-Peak measurements.

For measurements above the frequency range of the receivers, a spectrum analyzer is utilized because it provides visibility of the entire spectrum along with the precision and versatility required to support engineering analysis. Average measurements above 1000MHz are performed on the spectrum analyzer using the linear-average method with a resolution bandwidth of 1 MHz and a video bandwidth of 10 Hz, unless the signal is pulsed in which case the average (or video) bandwidth of the measuring instrument is reduced to onset of pulse desensitization and then increased.

INSTRUMENT CONTROL COMPUTER

The receivers utilize either a Rohde & Schwarz EZM Spectrum Monitor/Controller or contain an internal Spectrum Monitor/Controller to view and convert the receiver measurements to the field strength at an antenna or voltage developed at the LISN measurement port, which is then compared directly with the appropriate specification limit. This provides faster, more accurate readings by performing the conversions described under Sample Calculations within the Test Procedures section of this report. Results are printed in a graphic and/or tabular format, as appropriate. A personal computer is used to record all measurements made with the receivers.

The Spectrum Monitor provides a visual display of the signal being measured. In addition, the controller or a personal computer run automated data collection programs which control the receivers. This provides added accuracy since all site correction factors, such as cable loss and antenna factors are added automatically.

LINE IMPEDANCE STABILIZATION NETWORK (LISN)

Line conducted measurements utilize a fifty microhenry Line Impedance Stabilization Network as the monitoring point. The LISN used also contains a 250 uH CISPR adapter. This network provides for calibrated radio frequency noise measurements by the design of the internal low pass and high pass filters on the EUT and measurement ports, respectively.

FILTERS/ATTENUATORS

External filters and precision attenuators are often connected between the receiving antenna or LISN and the receiver. This eliminates saturation effects and non-linear operation due to high amplitude transient events.

ANTENNAS

A loop antenna is used below 30 MHz. For the measurement range 30 MHz to 1000 MHz either a combination of a biconical antenna and a log periodic or a bi-log antenna is used. Above 1000 MHz, horn antennas are used. The antenna calibration factors to convert the received voltage to an electric field strength are included with appropriate cable loss and amplifier gain factors to determine an overall site factor, which is then programmed into the test receivers or incorporated into the test software.

ANTENNA MAST AND EQUIPMENT TURNTABLE

The antennas used to measure the radiated electric field strength are mounted on a non-conductive antenna mast equipped with a motor-drive to vary the antenna height. Measurements below 30 MHz are made with the loop antenna at a fixed height of 1m above the ground plane.

ANSI C63.4:2003 specifies that the test height above ground for table mounted devices shall be 80 centimeters. Floor mounted equipment shall be placed on the ground plane if the device is normally used on a conductive floor or separated from the ground plane by insulating material from 3 to 12 mm if the device is normally used on a non-conductive floor. During radiated measurements, the EUT is positioned on a motorized turntable in conformance with this requirement.

INSTRUMENT CALIBRATION

All test equipment is regularly checked to ensure that performance is maintained in accordance with the manufacturer's specifications. All antennas are calibrated at regular intervals with respect to tuned half-wave dipoles. An exhibit of this report contains the list of test equipment used and calibration information.

TEST PROCEDURES

EUT AND CABLE PLACEMENT

The regulations require that interconnecting cables be connected to the available ports of the unit and that the placement of the unit and the attached cables simulate the worst case orientation that can be expected from a typical installation, so far as practicable. To this end, the position of the unit and associated cabling is varied within the guidelines of ANSI C63.4:2003, and the worst-case orientation is used for final measurements.

CONDUCTED EMISSIONS

Conducted emissions are measured at the plug end of the power cord supplied with the EUT. Excess power cord length is wrapped in a bundle between 30 and 40 centimeters in length near the center of the cord. Preliminary measurements are made to determine the highest amplitude emission relative to the specification limit for all the modes of operation. Placement of system components and varying of cable positions are performed in each mode. A final peak mode scan is then performed in the position and mode for which the highest emission was noted on all current carrying conductors of the power cord.

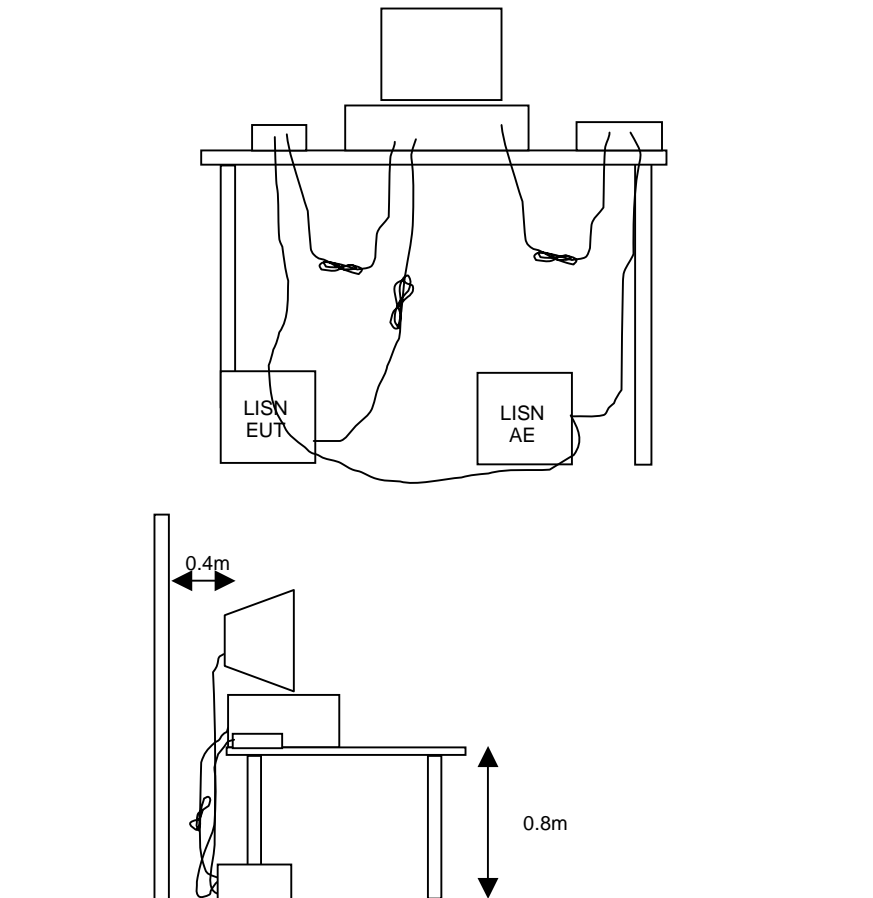

RADIATED EMISSIONS

A preliminary scan of the radiated emissions is performed in which all significant EUT frequencies are identified with the system in a nominal configuration. At least two scans are performed, one scan for each antenna polarization (horizontal and vertical; loop parallel and perpendicular to the EUT). During the preliminary scans, the EUT is rotated through 360°, the antenna height is varied (for measurements above 30 MHz) and cable positions are varied to determine the highest emission relative to the limit. Preliminary scans may be performed in a fully anechoic chamber for the purposes of identifying the frequencies of the highest emissions from the EUT.

A speaker is provided in the receiver to aid in discriminating between EUT and ambient emissions. Other methods used during the preliminary scan for EUT emissions involve scanning with near field magnetic loops, monitoring I/O cables with RF current clamps, and cycling power to the EUT.

Final maximization is a phase in which the highest amplitude emissions identified in the spectral search are viewed while the EUT azimuth angle is varied from 0 to 360 degrees relative to the receiving antenna. The azimuth, which results in the highest emission is then maintained while varying the antenna height from one to four meters (for measurements above 30 MHz, measurements below 30 MHz are made with the loop antenna at a fixed height of 1m). The result is the identification of the highest amplitude for each of the highest peaks. Each recorded level is corrected in the receiver using appropriate factors for cables, connectors, antennas, and preamplifier gain.

When testing above 18 GHz, the receive antenna is located at 1meter from the EUT and the antenna height is restricted to a maximum of 2.5 meters.

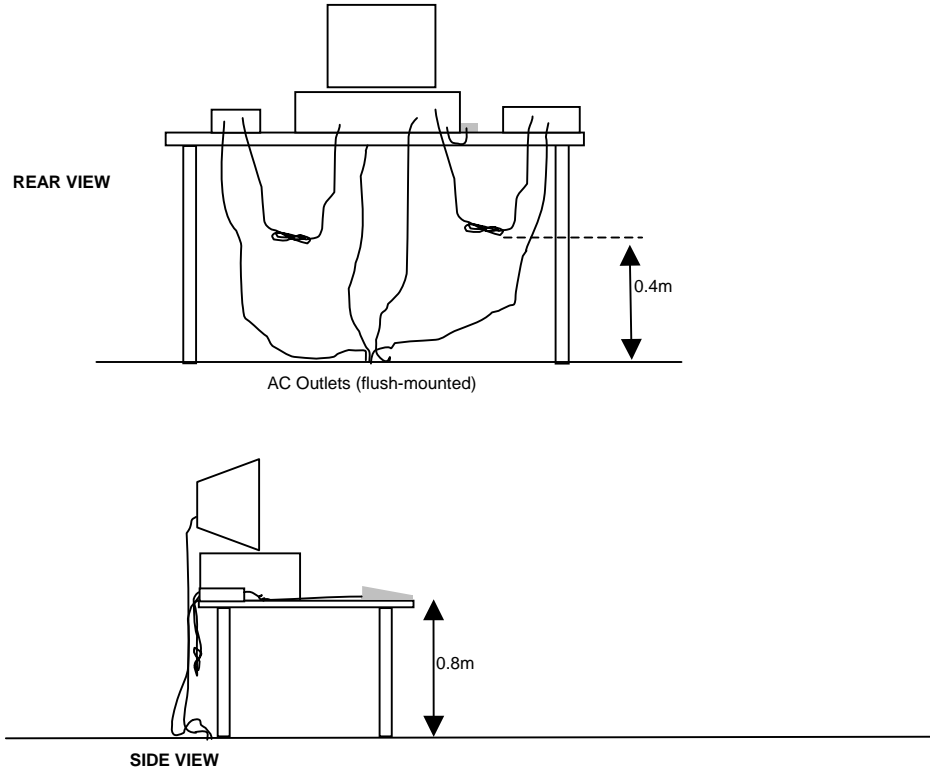

Typical Test Configuration for Radiated Field Strength Measurements

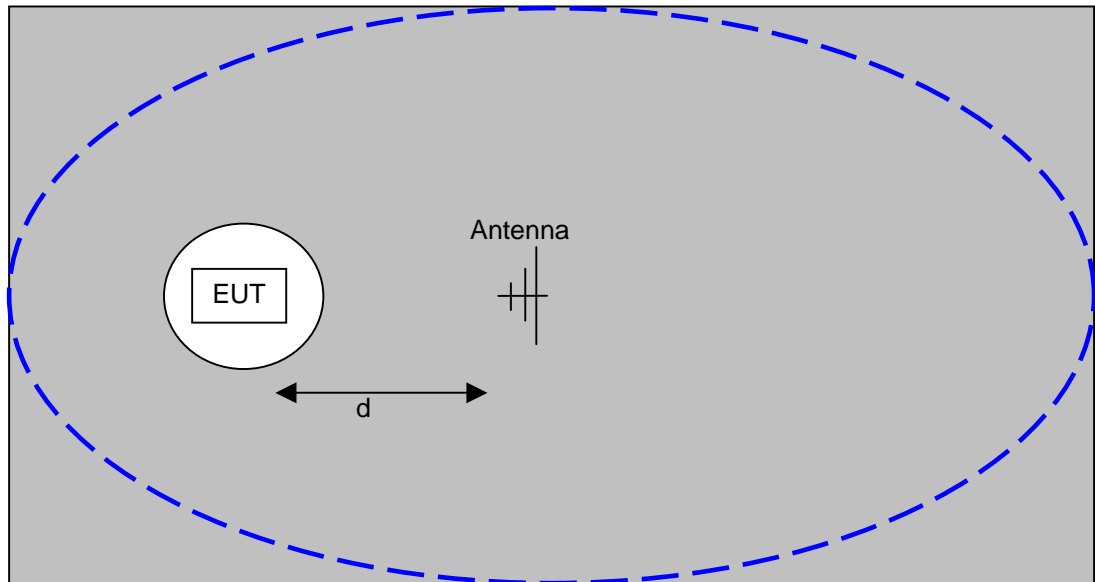

The ground plane extends beyond the ellipse defined in CISPR 16 / CISPR 22 / ANSI C63.4 and is large enough to accommodate test distances (d) of 3m and 10m. Refer to the test data tables for the actual measurement distance.

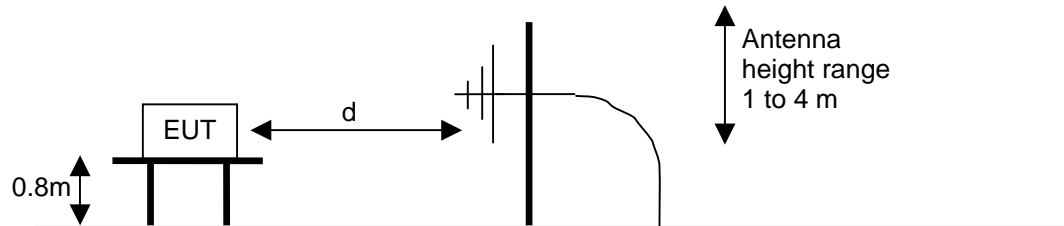

Test Configuration for Radiated Field Strength Measurements
OATS- Plan and Side Views

BANDWIDTH MEASUREMENTS

The 6dB, 20dB and/or 26dB signal bandwidth is measured in using the bandwidths recommended by ANSI C63.4. When required, the 99% bandwidth is measured using the methods detailed in RSS GEN.

SPECIFICATION LIMITS AND SAMPLE CALCULATIONS

The limits for conducted emissions are given in units of microvolts, and the limits for radiated emissions are given in units of microvolts per meter at a specified test distance. Data is measured in the logarithmic form of decibels relative to one microvolt, or dB microvolts (dBuV). For radiated emissions, the measured data is converted to the field strength at the antenna in dB microvolts per meter (dBuV/m). The results are then converted to the linear forms of uV and uV/m for comparison to published specifications.

For reference, converting the specification limits from linear to decibel form is accomplished by taking the base ten logarithm, then multiplying by 20. These limits in both linear and logarithmic form are as follows:

GENERAL TRANSMITTER RADIATED EMISSIONS SPECIFICATION LIMITS

The table below shows the limits for the spurious emissions from transmitters that fall in restricted bands¹ (with the exception of transmitters operating under FCC Part 15 Subpart D and RSS 210 Annex 9), the limits for all emissions from a low power device operating under the general rules of RSS 310 (tables 3 and 4), RSS 210 (table 2) and FCC Part 15 Subpart C section 15.209.

Frequency Range (MHz)	Limit (uV/m)	Limit (dBuV/m @ 3m)
0.009-0.490	$2400/F_{\text{KHz}} @ 300\text{m}$	$67.6-20*\log_{10}(F_{\text{KHz}}) @ 300\text{m}$
0.490-1.705	$24000/F_{\text{KHz}} @ 30\text{m}$	$87.6-20*\log_{10}(F_{\text{KHz}}) @ 30\text{m}$
1.705 to 30	30 @ 30m	29.5 @ 30m
30 to 88	100 @ 3m	40 @ 3m
88 to 216	150 @ 3m	43.5 @ 3m
216 to 960	200 @ 3m	46.0 @ 3m
Above 960	500 @ 3m	54.0 @ 3m

¹ The restricted bands are detailed in FCC 15.203, RSS 210 Table 1 and RSS 310 Table 2

SAMPLE CALCULATIONS - CONDUCTED EMISSIONS

Receiver readings are compared directly to the conducted emissions specification limit (decibel form) as follows:

$$R_r - S = M$$

where:

R_r = Receiver Reading in dBuV

S = Specification Limit in dBuV

M = Margin to Specification in +/- dB

SAMPLE CALCULATIONS - RADIATED EMISSIONS

Receiver readings are compared directly to the specification limit (decibel form). The receiver internally corrects for cable loss, preamplifier gain, and antenna factor. The calculations are in the reverse direction of the actual signal flow, thus cable loss is added and the amplifier gain is subtracted. The Antenna Factor converts the voltage at the antenna coaxial connector to the field strength at the antenna elements.

A distance factor, when used for electric field measurements above 30MHz, is calculated by using the following formula:

$$F_d = 20 * \text{LOG}_{10} (D_m/D_s)$$

where:

F_d = Distance Factor in dB

D_m = Measurement Distance in meters

D_s = Specification Distance in meters

For electric field measurements below 30MHz the extrapolation factor is either determined by making measurements at multiple distances or a theoretical value is calculated using the formula:

$$F_d = 40 * \text{LOG}_{10} (D_m/D_s)$$

Measurement Distance is the distance at which the measurements were taken and Specification Distance is the distance at which the specification limits are based. The antenna factor converts the voltage at the antenna coaxial connector to the field strength at the antenna elements.

The margin of a given emission peak relative to the limit is calculated as follows:

$$R_c = R_r + F_d$$

and

$$M = R_c - L_s$$

where:

R_r = Receiver Reading in dBuV/m

F_d = Distance Factor in dB

R_c = Corrected Reading in dBuV/m

L_s = Specification Limit in dBuV/m

M = Margin in dB Relative to Spec

SAMPLE CALCULATIONS - FIELD STRENGTH TO EIRP CONVERSION

Where the radiated electric field strength is expressed in terms of the equivalent isotropic radiated power (eirp), or where a field strength measurement of output power is made in lieu of a direct measurement, the following formula is used to convert between eirp and field strength at a distance of 3m from the equipment under test:

$$E = \frac{1000000 \sqrt{30 P}}{3} \quad \text{microvolts per meter}$$

where P is the eirp (Watts)

EXHIBIT 1: Test Equipment Calibration Data

1 Page

Radiated Emissions, 25-Jun-08**Engineer: Rafael Varelas**

<u>Manufacturer</u>	<u>Description</u>	<u>Model #</u>	<u>Asset #</u>	<u>Cal Due</u>
EMCO	Antenna, Horn, 1-18 GHz	3115	1561	10-Jun-10
Hewlett Packard	Microwave Preamplifier, 1-26.5GHz	8449B	785	27-May-09
Hewlett Packard	EMC Spectrum Analyzer, 9 kHz - 6.5 GHz	8595EM	787	19-Feb-09
EMCO	Log Periodic Antenna, 0.2-1 GHz	3146	1294	28-Aug-08
Rohde & Schwarz	Test Receiver, 0.009-2750 MHz	ESN	1332	29-Jan-09

Conducted Emissions - AC Power Ports, 25-Jun-08**Engineer: Mehran Birgani**

<u>Manufacturer</u>	<u>Description</u>	<u>Model #</u>	<u>Asset #</u>	<u>Cal Due</u>
Elliott Laboratories	LISN, FCC / CISPR	LISN-3, OATS	304	18-Jul-08
Hewlett Packard	EMC Spectrum Analyzer, 9 kHz - 6.5 GHz	8595EM	787	19-Feb-09
Rohde & Schwarz	Test Receiver, 0.009-2750 MHz	ESN	1332	29-Jan-09
Rohde & Schwarz	Pulse Limiter	ESH3 Z2	1398	12-Feb-09

Radiated Emissions, 25-Jun-08**Engineer: Rafael Varelas**

<u>Manufacturer</u>	<u>Description</u>	<u>Model #</u>	<u>Asset #</u>	<u>Cal Due</u>
EMCO	Antenna, Horn, 1-18 GHz	3115	1561	10-Jun-10
Hewlett Packard	Microwave Preamplifier, 1-26.5GHz	8449B	785	27-May-09
Hewlett Packard	EMC Spectrum Analyzer, 9 kHz - 6.5 GHz	8595EM	787	19-Feb-09
EMCO	Log Periodic Antenna, 0.2-1 GHz	3146	1294	28-Aug-08
Rohde & Schwarz	Test Receiver, 0.009-2750 MHz	ESN	1332	29-Jan-09
EMCO	Biconical Antenna, 30-300 MHz	3110B	1497	03-Jul-08

EXHIBIT 2: Test Measurement Data

13 Pages



EMC Test Data

Client:	Savi	Job Number:	J71722
Model:	SR-650-101	T-Log Number:	T71951
		Account Manager:	Dean Eriksen
Contact:	Eugene Schlindwein		
Emissions Spec:	FCC 15.240, 15.231a	Class:	B
Immunity Spec:	-	Environment:	-

EMC Test Data

For The

Savi

Model

SR-650-101

Date of Last Test: 6/25/2008

Client:	Savi	Job Number:	J71722
Model:	SR-650-101	T-Log Number:	T71951
Contact:	Eugene Schlindwein	Account Manager:	Dean Eriksen
Emissions Spec:	FCC 15.240, 15.231a	Class:	B
Immunity Spec:	-	Environment:	-

EUT INFORMATION

General Description

The EUT is an RFID tag reader that is designed to track asset tags that use Savi's 433.92 MHz transceivers. Normally, the EUT would be pole-mounted during operation. The EUT was treated as table-top equipment during testing to simulate the end-user environment. The electrical rating of the EUT is 92-125/184-250 VAC, 50/60 Hz, 300 mA or 12-24 VDC, 500 mA.

Equipment Under Test

Manufacturer	Model	Description	Serial Number	FCC ID
Savi Technology	SR-650-101	Fixed Reader	DEV0024-4	KL7-650R-V2

Other EUT Details

The EUT transmits four different control commands (Wake-Up, Hello, Sleep and Find) plus control/data signals. Apart from the wake-up command which is a continuous signal, all other commands have a duty cycle that is less than 60ms in a 100ms. The Wake-Up signal is a continuous signal that is transmitted for 2.5 seconds on the first transmitter and then 2.5 seconds on the second transmitter.

Each transmitter connects to a different antennas. The antennas are identical but arranged at 90 degrees to each other. All transmissions are made from one antenna or from the other to achieve an omni-directional pattern. All duty-cycles take into consideration combinations of transmissions from both antennas, that is the combination of any transmissions from transmitter number one followed by transmissions from antenna number 2 meet the requirements for timing as detailed in 15.231. Both transmitters cannot operate simultaneously.

The Theory of Operations details how the different types of transmissions meet the timing requirements for control signals or data signals.

EUT Enclosure

The EUT enclosure is primarily constructed of plastic. It has a diameter of 30 cm (12 in.) and a height of 14 cm (5.5 in.).

Modification History

Mod. #	Test	Date	Modification
1	-	-	None

Modifications applied are assumed to be used on subsequent tests unless otherwise stated as a further modification.



EMC Test Data

Client:	Savi	Job Number:	J71722
Model:	SR-650-101	T-Log Number:	T71951
Contact:	Eugene Schindwein	Account Manager:	Dean Eriksen
Emissions Spec:	FCC 15.240, 15.231a	Class:	B
Immunity Spec:	-	Environment:	-

Test Configuration #1 (emissions)

Local Support Equipment

Manufacturer	Model	Description	Serial Number	FCC ID
None				

Remote Support Equipment

Manufacturer	Model	Description	Serial Number	FCC ID
Savi	410R	SaviReader	-	KL7-410GR-V11
IBM	2635	Laptop PC	78-VA248 97/11	-

Interface Cabling and Ports

Port	Connected To	Cable(s)		
		Description	Shielded or Unshielded	Length(m)
Ethernet	Laptop	CAT 5	Unshielded	30
Savi Net In	410R	multiwire	Unshielded	30
Savi Net thru	410R	multiwire	Unshielded	30
AC in	AC Mains	3 wire	Unshielded	2

Note: The RS-232 port was not connected as the manufacturer stated that this is for configuration and servicing purposes and therefore would not normally be connected.

EUT Operation During Emissions

The EUT was continuously transmitting for transmitter mode tests. For receiver/digital device tests the EUT was pinged from the laptop and operated in receive mode.

Client:	Savi	Job Number:	J71722
Model:	SR-650-101	T-Log Number:	T71951
Contact:	Eugene Schlindwein	Account Manager:	Dean Eriksen
Standard:	FCC 15.240, 15.231a	Class:	B

Conducted Emissions - Power Ports

Test Specific Details

Objective: The objective of this test session is to perform final qualification testing of the EUT with respect to the specification listed above.

Date of Test: 6/25/2008 22:44	Config. Used: 1
Test Engineer: Rafael Varelas	Config Change: None
Test Location: SVOATS #2	EUT Voltage: 120V/60Hz

General Test Configuration

The EUT was located on a wooden table, 40 cm from a vertical coupling plane and 80cm from the LISN. Remote support equipment was located approximately 30 meters from the test area. All I/O connections were routed overhead.

Ambient Conditions:

Temperature:	14 °C
Rel. Humidity:	75 %

Summary of Results

Run #	Test Performed	Limit	Result	Margin
1	CE, AC Power,120V/60Hz	EN55022 Class B	Pass	40.4dBµV @ 3.319MHz (-5.6dB)

Modifications Made During Testing

No modifications were made to the EUT during testing

Deviations From The Standard

No deviations were made from the requirements of the standard.

Client: Savi	Job Number: J71722
Model: SR-650-101	T-Log Number: T71951
Contact: Eugene Schlindwein	Account Manager: Dean Eriksen
Standard: FCC 15.240, 15.231a	Class: B

Run #1: AC Power Port Conducted Emissions, 0.15 - 30MHz, 120V/60Hz
 S/N: DEV0024-5

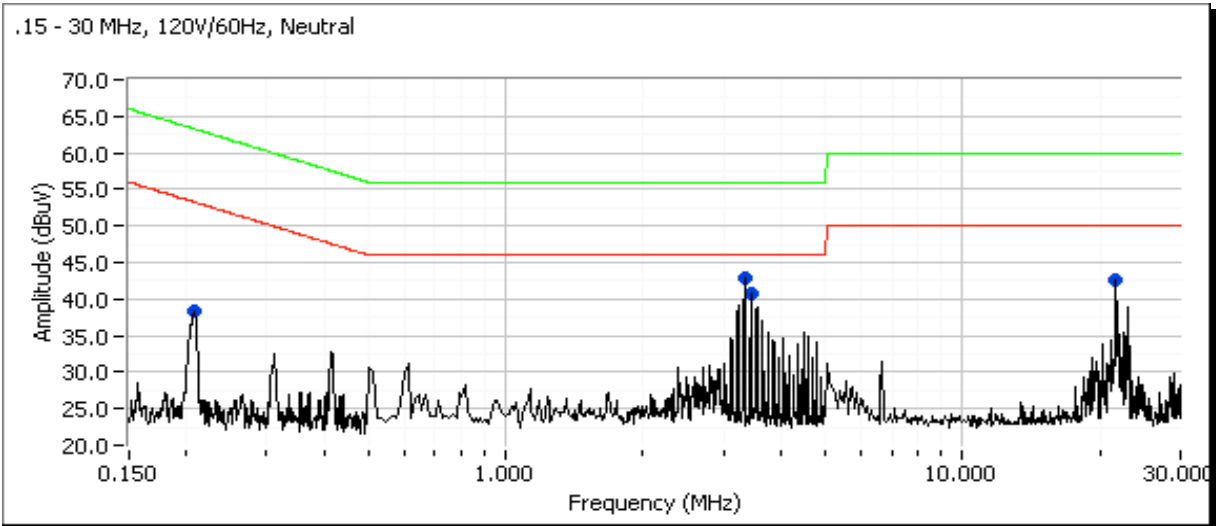
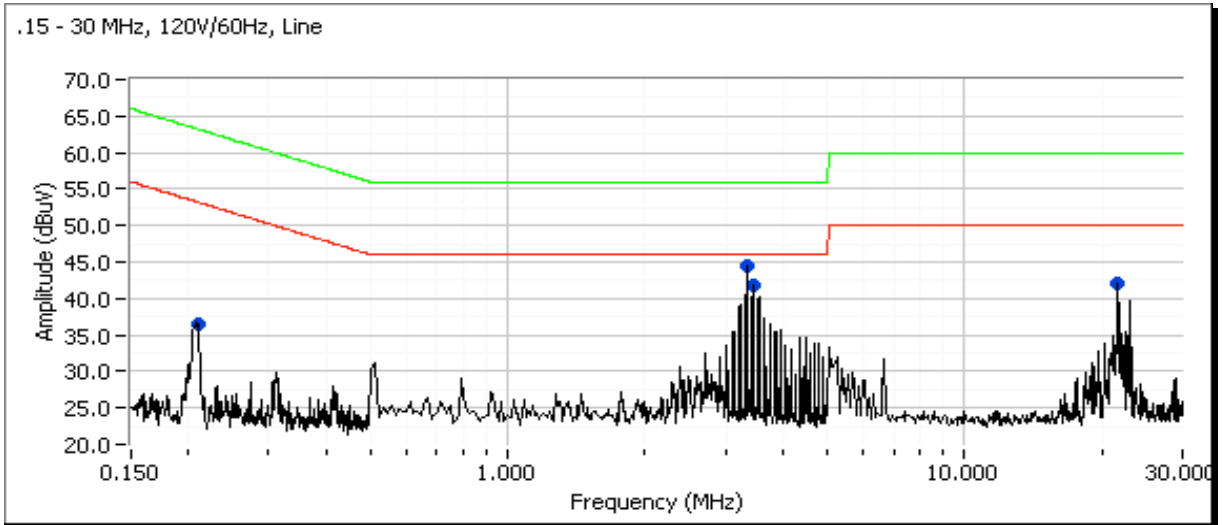

Client:	Savi	Job Number:	J71722
Model:	SR-650-101	T-Log Number:	T71951
Contact:	Eugene Schlindwein	Account Manager:	Dean Eriksen
Standard:	FCC 15.240, 15.231a	Class:	B

Run #1: Continued

Frequency MHz	Level dB μ V	AC Line	EN55022 B		Detector QP/Ave	Comments
			Limit	Margin		
3.319	40.4	Line 1	46.0	-5.6	AVG	
3.320	38.9	Neutral	46.0	-7.1	AVG	
3.423	38.4	Line 1	46.0	-7.6	AVG	
3.422	37.3	Neutral	46.0	-8.7	AVG	
21.665	38.9	Line 1	50.0	-11.1	AVG	
21.665	38.3	Neutral	50.0	-11.7	AVG	
3.319	43.3	Line 1	56.0	-12.7	QP	
3.320	42.2	Neutral	56.0	-13.8	QP	
3.423	41.6	Line 1	56.0	-14.4	QP	
0.208	38.4	Neutral	53.3	-14.9	Peak	
3.422	40.5	Neutral	56.0	-15.5	QP	
0.208	36.6	Line 1	53.2	-16.6	Peak	
21.665	42.1	Line 1	60.0	-17.9	QP	
21.665	41.5	Neutral	60.0	-18.5	QP	

Client:	Savi	Job Number:	J71722
Model:	SR-650-101	T-Log Number:	T71951
Contact:	Eugene Schlindwein	Account Manager:	Dean Eriksen
Spec:	FCC 15.240, 15.231a	Class:	B

Radiated Emissions - Transmitter Fundamental and Spurious

Test Specifics

Objective: The objective of this test session is to perform final qualification testing of the EUT with respect to the specification listed above.

Date of Test: 6/25/2008	Config. Used: 1
Test Engineer: Rafael Varelas	Config Change: None
Test Location: SVOATS #2	EUT Voltage: 120V/60Hz

General Test Configuration

The EUT and all local support equipment were located on the turntable for radiated emissions testing. Remote support equipment was located approximately 30 meters from the test area with all I/O connections running on top of the groundplane.

Unless otherwise specified, the measurement antenna was located 3 meters from the EUT.

Ambient Conditions:

Temperature:	14 °C
Rel. Humidity:	75 %

Summary of Results

Run #	Test Performed	Limit	Result	Margin
1	RE, 30 -4400 MHz Control/Data & Wake-Up	FCC 15.231(a) RSS 210	Pass	80.0dBµV/m @ 433.916MHz (-0.8dB)
1	RE, 30 -4400 MHz Control/Data & Wake-Up	FCC 15.240 RSS 210	Pass	80.0dBµV/m @ 433.916MHz (-0.8dB)
2	Second Harmonic	IEC 60601-1-2	Pass	28.1dBµV/m @ 867.831MHz (-18.9dB)
3	20dB and 99% Bandwidth	FCC 15.231 RSS-GEN	Pass	360kHz 146 kHz

Modifications Made During Testing:

No modifications were made to the EUT during testing

Deviations From The Standard

No deviations were made from the requirements of the standard.

Client:	Savi	Job Number:	J71722
Model:	SR-650-101	T-Log Number:	T71951
Contact:	Eugene Schlindwein	Account Manager:	Dean Eriksen
Spec:	FCC 15.240, 15.231a	Class:	B

Run #1: Radiated Emissions, 30-4400 MHz

Measurements made with 120kHz BW and Peak detector. See note 1 for average values.

Fundamental - TX with Unit serial number: DEV0024-5 with setting 48 (Control)

Frequency	Level	Pol	FCC 15.231(a)		Detector	Azimuth	Height	Comments
MHz	dB μ V/m	v/h	Limit	Margin	Pk/QP/Avg	degrees	meters	
433.916	80.0	H	80.8	-0.8	AVG	234	1.0	
433.916	84.4	H	100.8	-16.4	PK	234	1.0	
433.912	79.6	V	80.8	-1.2	AVG	354	1.1	
433.912	84.0	V	100.8	-16.8	PK	354	1.1	

Fundamental - TX with Unit serial number: DEV0024-5 with setting 58 (Wake up)

Frequency	Level	Pol	FCC 15.231(a)		Detector	Azimuth	Height	Comments
MHz	dB μ V/m	v/h	Limit	Margin	Pk/QP/Avg	degrees	meters	
433.912	79.6	H	80.8	-1.2	AVG	234	1.0	
433.912	79.6	H	100.8	-21.2	PK	234	1.0	
433.912	79.5	V	80.8	-1.3	AVG	354	1.1	
433.912	79.5	V	100.8	-21.3	PK	354	1.1	

Operation under 15.240

Fundamental - TX with Unit serial number: DEV0024-5 with setting 48 (Control)

Frequency	Level	Pol	FCC 15.240		Detector	Azimuth	Height	Comments
MHz	dB μ V/m	V/H	Limit	Margin	Pk/QP/Avg	degrees	meters	
433.916	80.0	H	80.8	-0.8	AVG	234	1.0	
433.916	84.4	H	94.8	-10.4	PK	234	1.0	
433.912	79.6	V	80.8	-1.2	AVG	354	1.1	
433.912	84.0	V	94.8	-10.8	PK	354	1.1	

Fundamental - TX with Unit serial number: DEV0024-5 with setting 58 (Wake up)

Frequency	Level	Pol	FCC 15.231(a)		Detector	Azimuth	Height	Comments
MHz	dB μ V/m	v/h	Limit	Margin	Pk/QP/Avg	degrees	meters	
433.912	79.6	H	80.8	-1.2	AVG	234	1.0	
433.912	79.6	H	94.8	-15.2	PK	234	1.0	
433.912	79.5	V	80.8	-1.3	AVG	354	1.1	
433.912	79.5	V	94.8	-15.3	PK	354	1.1	

Note: Average readings were calculated from the peak readings by applying a duty cycle correction factor based on the highest duty cycle of all pulsed transmissions (60% in any 100mS period equals a duty cycle correction of -4.4dB). By meeting the limit for data signals, all of the pulsed transmission meet the requirements with respect to field strength of fundamental and spurious emissions for both control and data signals.

Note 1: Preliminary measurements on both transmitters demonstrated that transmitter #1 produced the highest signal level. All measurements were, therefore, made on transmitter # 1.



EMC Test Data

Client:	Savi	Job Number:	J71722
Model:	SR-650-101	T-Log Number:	T71951
Contact:	Eugene Schlindwein	Account Manager:	Dean Eriksen
Spec:	FCC 15.240, 15.231a	Class:	B

Other Spurious Emissions

S/N: DEV0024-5

Frequency MHz	Level dB μ V/m	Pol v/h	FCC 15.240		Detector Pk/QP/Avg	Azimuth degrees	Height meters	Comments
			Limit	Margin				
867.831	38.6	V	46.0	-7.4	QP	166	2.3	QP control with setting of 48
867.831	36.9	H	46.0	-9.1	QP	274	1.0	QP control with setting of 48
1301.860	30.9	H	54.0	-23.1	AVG	264	1.0	RB 1 MHz; VB: 10 Hz
1301.860	42.2	H	74.0	-31.8	PK	264	1.0	RB 1 MHz; VB: 1 MHz
1735.770	37.0	H	54.0	-17.0	AVG	48	1.7	RB 1 MHz; VB: 10 Hz
1735.770	47.6	H	74.0	-26.4	PK	48	1.7	RB 1 MHz; VB: 1 MHz
2168.120	37.2	H	54.0	-16.8	AVG	264	2.6	RB 1 MHz; VB: 10 Hz
2168.120	49.2	H	74.0	-24.8	PK	264	2.6	RB 1 MHz; VB: 1 MHz
2604.740	36.6	H	54.0	-17.4	AVG	196	1.0	RB 1 MHz; VB: 10 Hz
2604.740	47.2	H	74.0	-26.8	PK	196	1.0	RB 1 MHz; VB: 1 MHz
1301.970	30.7	V	54.0	-23.3	AVG	299	1.0	RB 1 MHz; VB: 10 Hz
1301.970	41.6	V	74.0	-32.4	PK	299	1.0	RB 1 MHz; VB: 1 MHz
1735.770	38.8	V	54.0	-15.2	AVG	124	1.0	RB 1 MHz; VB: 10 Hz
1735.770	49.2	V	74.0	-24.8	PK	124	1.0	RB 1 MHz; VB: 1 MHz
2169.460	34.9	V	54.0	-19.1	AVG	360	1.4	RB 1 MHz; VB: 10 Hz
2169.460	46.4	V	74.0	-27.6	PK	360	1.4	RB 1 MHz; VB: 1 MHz
2603.370	36.9	V	54.0	-17.1	AVG	291	2.7	RB 1 MHz; VB: 10 Hz
2603.370	47.7	V	74.0	-26.3	PK	291	2.7	RB 1 MHz; VB: 1 MHz

Note 1:	Preliminary measurements on both transmitters demonstrated that transmitter #1 produced the highest signal level. All measurements were, therefore, made on transmitter # 1.
Note 2:	Peak and average measurements below 1GHz made using the test receiver's detectors and a 120kHz bandwidth. Peak measurements above 1GHz were made using RBW=VBW=1MHz. The VBW was reduced to 10Hz for average measurements.

Client: Savi	Job Number: J71722
Model: SR-650-101	T-Log Number: T71951
Contact: Eugene Schlindwein	Account Manager: Dean Eriksen
Spec: FCC 15.240, 15.231a	Class: B

Run #2: Radiated Emissions, 30-1000 MHz - Harmonics versus IEC 60601-1-2 limit.

S/N: DEV0024-5

The highest signal level at the second harmonic from the previous runs was measured at 10m:

Frequency	Level	Pol	EN55011 A		Detector	Azimuth	Height	Comments
MHz	dB μ V/m	V/H	Limit	Margin	Pk/QP/Avg	degrees	meters	
867.831	28.1	V	47.0	-18.9	QP	166	2.3	
867.831	26.4	H	47.0	-20.6	QP	274	1.0	

Run #3a: 20dB Bandwidth

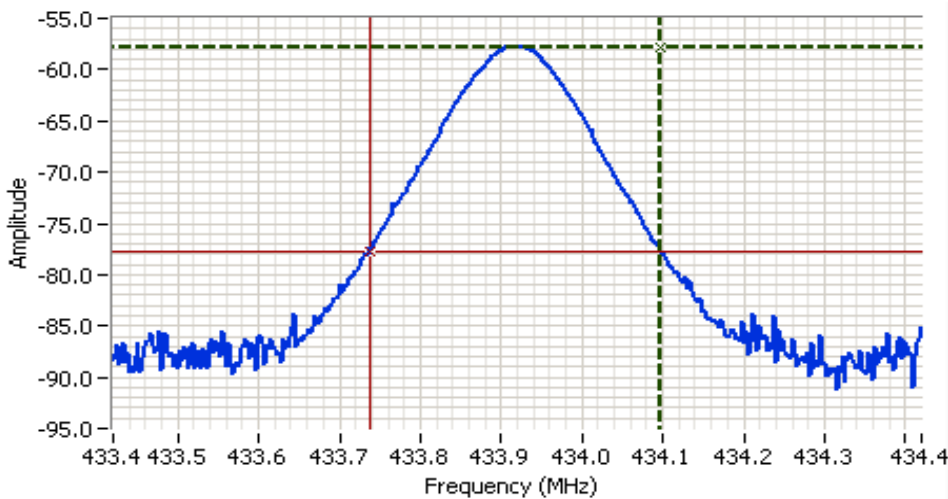

Analyzer Settings

HP8595EM
CF: 433.920 MHz
SPAN: 1.000 MHz
RB 100 kHz
VB 100 kHz
Detector POS
Att 0
RL Offset 0.00
Sweep Time 20.0ms
Ref Lvl: -52.00DBM

Comments

20dB BW: 360 kHz

Cursor 1	434.0975	-57.77	
Cursor 2	433.7375	-77.77	

Delta Freq. 360 kHz
Delta Amplitude 20.00



20dB BW Limit = 1.08 MHz

Client: Savi	Job Number: J71722
Model: SR-650-101	T-Log Number: T71951
Contact: Eugene Schlindwein	Account Manager: Dean Eriksen
Spec: FCC 15.240, 15.231a	Class: B

Run #3b: 99% Bandwidth

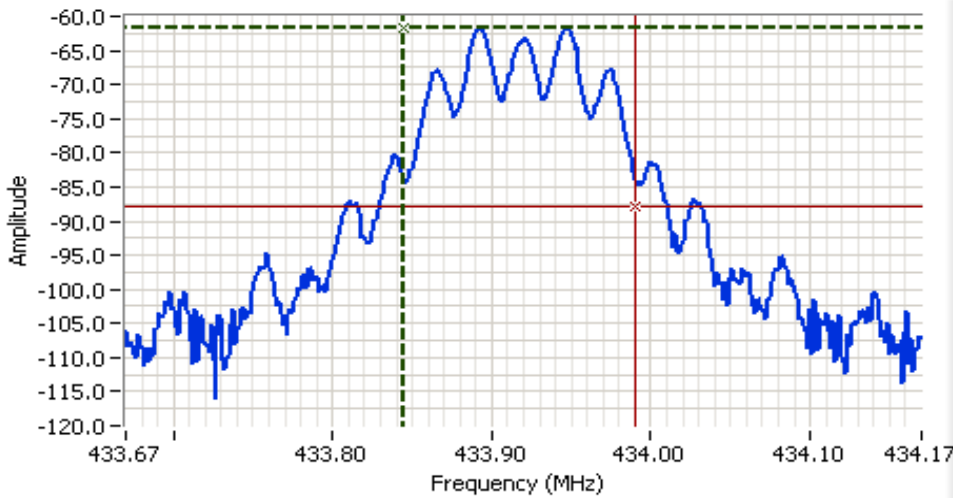

Analyzer Settings
 HP8595EM
 CF: 433.920 MHz
 SPAN: 500 kHz
 RB 10.00 kHz
 VB 30.0 kHz
 Detector POS
 Att 0
 RL Offset 0.00
 Sweep Time 30.0ms
 Ref Lvl: -49.00DBM

Comments
 99% power BW:
 146 kHz

Cursor 1	433.8446	-61.79	⊕	⊖	⊞
Cursor 2	433.9905	-87.79	⊕	⊖	⊞

Delta Freq. 146 kHz
 Delta Amplitude 26.00



Client:	Savi	Job Number:	J71722
Model:	SR-650-101	T-Log Number:	T71951
Contact:	Eugene Schlindwein	Account Manager:	Dean Eriksen
Spec:	FCC 15.240, 15.231a	Class:	B

Radiated Emissions - Receiver Spurious & Digital Device

Test Specifics

Objective: The objective of this test session is to perform final qualification testing of the EUT with respect to the specification listed above.

Date of Test: 6/25/2008
 Test Engineer: Rafael Varelas
 Test Location: SV OATS # 2

Config. Used: 1
 Config Change: None
 EUT Voltage: 120V/60Hz

General Test Configuration

The EUT and all local support equipment were located on the turntable for radiated emissions testing. Remote support equipment was located approximately 30 meters from the test area with all I/O connections running on top of the groundplane.

Unless otherwise specified, the measurement antenna was located 3 meters from the EUT.

Note, **preliminary** testing indicates that the emissions were maximized by orientation of the EUT and elevation of the measurement antenna. **Maximized** testing indicated that the emissions were maximized by orientation of the EUT, elevation of the measurement antenna, and manipulation of the EUT's interface cables.

Note, for testing above 1 GHz, the FCC specifies the limit as an average measurement. In addition, the FCC states that the peak reading of any emission above 1 GHz, can not exceed the average limit by more than 20 dB.

Ambient Conditions: Temperature: 14 °C
 Rel. Humidity: 75 %

Summary of Results

Run #	Test Performed	Limit	Result	Margin
1	RE, 30 - 2000 MHz, Receiver Spurious Emissions	FCC 15.109 / RSS 210	Pass	31.3dB μ V/m @ 423.21MHz (-14.7dB)
2	RE, 30 - 1000 MHz	IEC 60601-1-2 Class A	Pass	20.8dB μ V/m @ 423.21MHz (-26.2dB)

Modifications Made During Testing:

No modifications were made to the EUT during testing



EMC Test Data

Client:	Savi	Job Number:	J71722
Model:	SR-650-101	T-Log Number:	T71951
Contact:	Eugene Schlindwein	Account Manager:	Dean Eriksen
Spec:	FCC 15.240, 15.231a	Class:	B

Deviations From The Standard

No deviations were made from the requirements of the standard.

Run #1: Radiated Emissions, 30-2000 MHz - Receive Mode

S/N: DEV0024-5

Frequency	Level	Pol	FCC15.109/RSS 210		Detector	Azimuth	Height	Comments
MHz	dB μ V/m	v/h	Limit	Margin	Pk/QP/Avg	degrees	meters	
423.212	28.4	V	46.0	-17.6	QP	120	1.1	
846.424	28.0	V	46.0	-18.0	QP	149	1.0	
423.212	31.3	H	46.0	-14.7	QP	152	1.0	
846.424	28.5	H	46.0	-17.5	QP	256	2.2	
1270.380	31.1	V	54.0	-22.9	AVG	168	1.0	
1270.380	42.7	V	74.0	-31.3	PK	168	1.0	
1269.990	31.4	H	54.0	-22.6	AVG	233	2.7	
1269.990	46.2	H	74.0	-27.8	PK	233	2.7	

Run #2: Radiated Emissions, EN 60601-1-2 Class A limit.

The highest signal level at the second harmonic from the previous runs was measured at 10m.

S/N: DEV0024-5

Frequency	Level	Pol	EN55011 A		Detector	Azimuth	Height	Comments
MHz	dB μ V/m	v/h	Limit	Margin	Pk/QP/Avg	degrees	meters	
423.212	17.9	V	47.0	-29.1	QP	120	1.1	LO
846.424	17.5	V	47.0	-29.5	QP	149	1.0	Lo 2nd
423.212	20.8	H	47.0	-26.2	QP	152	1.0	LO
846.424	18.0	H	47.0	-29.0	QP	256	2.2	Lo 2nd

Note - measurements were made at 3m and corrected to the EN 55011 Class A limit for a 10m measurement.

EXHIBIT 3: Photographs of Test Configurations

EXHIBIT 4: Proposed FCC ID Label & Label Location

*EXHIBIT 5: Detailed Photographs
of Savi Technology, Inc. Model SR-650-101 Construction*

EXHIBIT 6: Operator's Manual
for Savi Technology, Inc. Model SR-650-101

*EXHIBIT 7: Block Diagram
of Savi Technology, Inc. Model SR-650-101*

***EXHIBIT 8: Schematic Diagrams
for Savi Technology, Inc. Model SR-650-101***

*EXHIBIT 9: Theory of Operation
for Savi Technology, Inc. Model SR-650-101*

EXHIBIT 10: Advertising Literature