

APPLICATION		REVISION RECORD			
NEXT ASSEMBLY	USED ON	LTR	DESCRIPTION	APPROVED	DATE
840-03642-001	APL01	A	EO#2651 INITIAL RELEASE	S/E.S.	09/13/01
860-03660-001	APL01	B	EO#2695 ADDED -002	S/E.S.	
		C	EO#	NOT RELEASED	

5. SAVI LOGO: MAIN BODY IS PMS#293 (BLUE), DOT OVER "I" IS PMS#200 (RED)
4. LABEL DIMENSIONS MAY BE ADJUSTED TO CLOSEST STANDARD DIE.
3. SPECIFICATIONS

MATERIAL	FASTRIP S-333/50# (2MIL) POLYESTER WITH S333 ADHESIVE (1 MIL)
COLOR	BLACK LETTERS ON CLEAR BACKGROUND
FONT	ARIAL NARROW
LAMINATION	1 MIL MATTE CLEAR POLYESTER

2. LABEL SHALL BE MANUFACTURED BY A UL APPROVED VENDOR. VENDOR SHALL HAVE A CURRENT SIGNED "PRINTER AGREEMENT" ON FILE WITH UL PER UL MARKING AND LABELING SYSTEMS AND SHALL SUPPLY EACH PACKAGE OR ROLL MARKED WITH COMPANY NAME AND LABEL DESIGNATION PER UL MARKING AND LABELING SYSTEMS.

1. DIMENSIONS ARE IN INCHES, ± 0.15

NOTES: (UNLESS OTHERWISE SPECIFIED)

DRAWN	E SAMPLEY	DATE	8/23/01	 615 TASMAN DRIVE SUNNYVALE, CALIFORNIA 94089			
CHECKED	S/R ORTON	DATE	9/12/01				
ENGINEER	S/P KELESHIAN	DATE	9/13/01				
PRODUCTION	S/B MATTOON	DATE	9/13/01				
MATERIAL	S/S DeMEDEIROS	DATE	9/13/01				
SUSTAINING	S/R PEARSON	DATE	9/13/01				
PROJECT LEADER	S/R ORTON	DATE	9/13/01	TITLE	LABEL, FCC ID / ETL / CE SIGNPOST		
DATA CONTROL	S/E SAMPLEY	DATE	9/13/01	CODE	SIZE	DRAWING No:	REV:
				APL01	A	735-03640-TAB	C
				SCALE: NA	FILE NAME: 73503640.TCW	SHEET 1 OF 2	



-001

CODE	SIZE	DRAWING No:	REV:
APL01	A	735-03640-TAB	C
SCALE: N/A	FILENAME :	SHEET 2	

4

3

DWG NO.

840-03642-TAB

SH

2

REV

C

1

REVISIONS				
ZONE	REV	DESCRIPTION	DATE	APPROVED

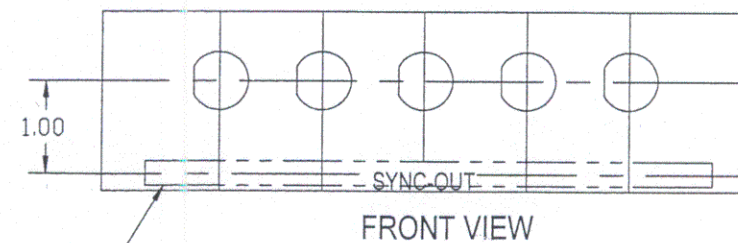
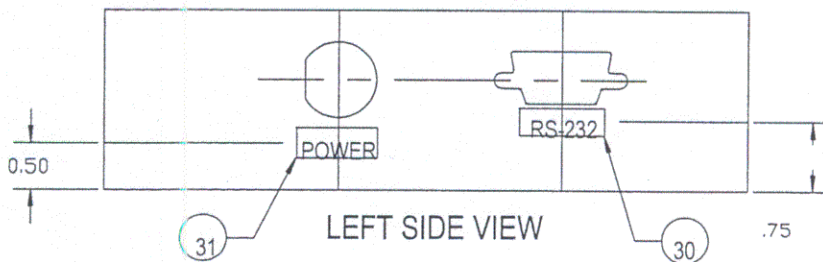
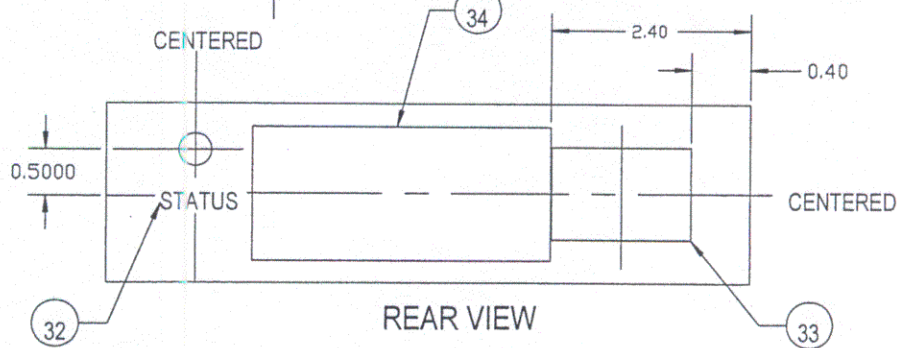
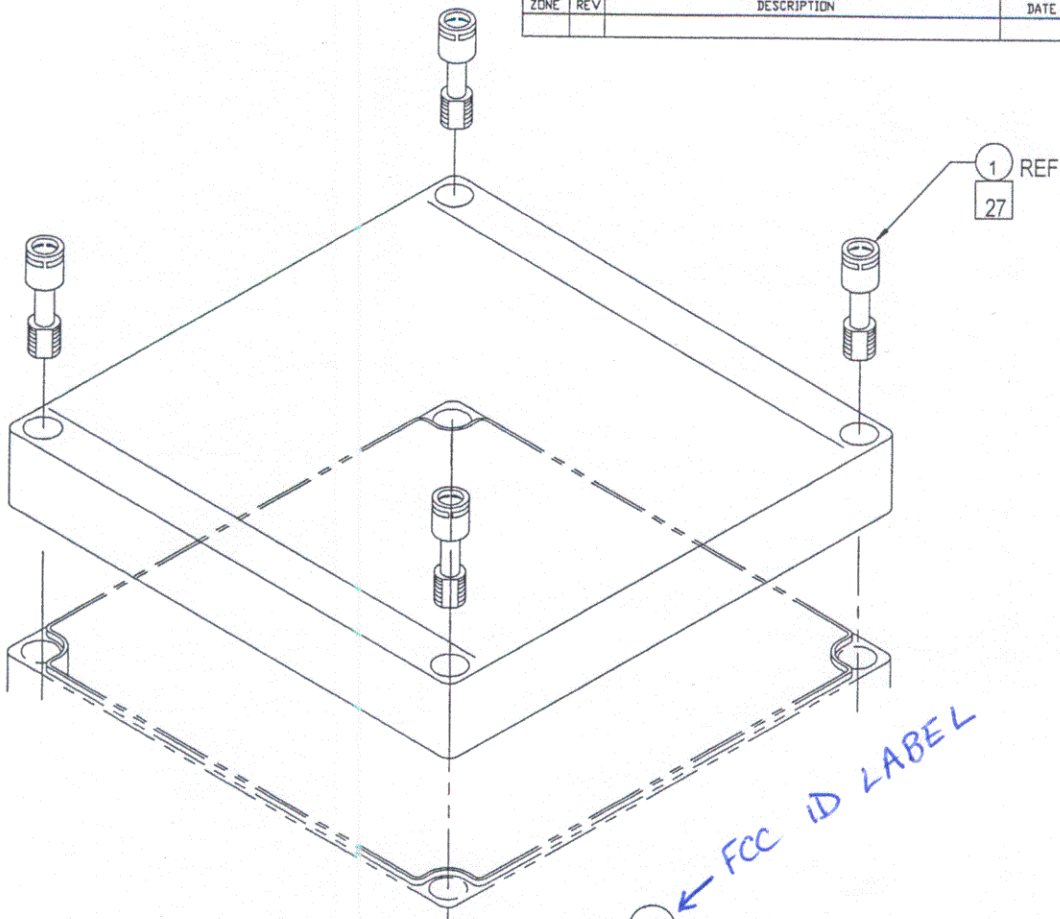

COMPUTER GENERATED
DRAWING - DATA BASE
MUST BE UPDATED

SIZE	CODE	DRAWING NO.	REV
D	APL01	840-03642-TAB	C
SCALE:	FILE NAME:	84003642A	SHEET 2 OF 2

D

FOLD

C

B

B

REV

C

SH

2

DWG NO.

840-03642-TAB

DWG NO.

840-03642-TAB

A

4

FOLD

3

2

1

IX
IX
IX

18 8X
23 8X
27 8X
1

4X (REF)

1

2 4X
26