



Installation & Operation Manual

ZP3102IN-5

ZP3102MY-5

ZP3102EU-5

ZP3102RU-5

ZP3102US-5

ZP3102IL-5

ZP3102KR-5

ZP3102HK-5

ZP3102JP-5

ZP3102BR-5

**Wireless PIR Motion Sensor
(Temperature Sensor Built-In)**

ZP 3102-5 | V1 | 1031125 | 6B1Z-31002

Introduction

Thanks for choosing the Vision's wireless PIR motion sensor of the home security device. This sensor is a Z-Wave™ enabled device (interoperable, two-way RF mesh networking technology) and is fully compatible with any Z-Wave™ enabled network and its security framework. Every mains powered Z-Wave™ enabled device acts as a signal repeater and multiple devices result in more possible transmission routes which helps eliminate "RF dead-spots".

Z-Wave™ enabled device displaying the Z-Wave™ logo can also be used with it regardless of the manufacturer, and ours can also be used in other manufacturer's Z-Wave™ enabled networks. This sensor monitors movement, and send Z-Wave™ signal when movement is detected inside the building. With Temperature sensor built inside, it will send the signal out when temperature changed. When the device is secure included into Z-Wave network, above communication will be encrypted.

Product Description and Specification

*** For indoor use only ***

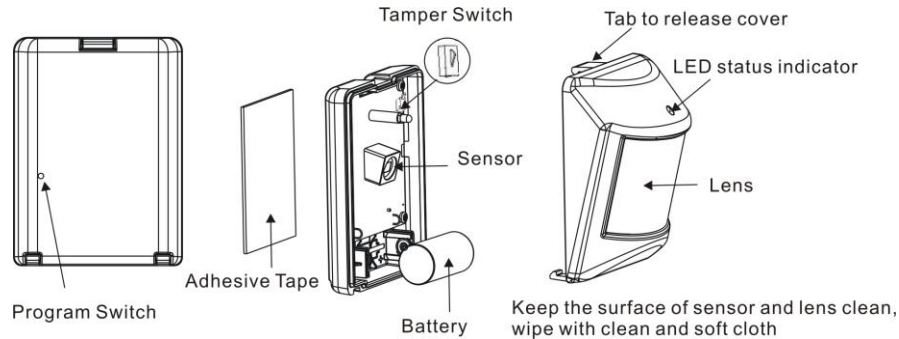

Specification:	Package Content:	
Protocol: Z-Wave™ (ZM5202)	1pc	ZP 3102 sensor
Frequency Range:	1pc	Adhesive tape for sensor
865.22MHz (ZP3102IN-5)	1pc	CR123A Lithium Battery
868.10MHz (ZP3102MY-5)	1pc	Installation & Operation Manual
868.42MHz (ZP3102EU-5)		
869.00MHz (ZP3102RU-5)		
908.42MHz (ZP3102US-5)		
916.00MHz (ZP3102IL-5)		
919.70MHz (ZP3102KR-5)		
919.80MHz (ZP3102HK-5)		
920.00MHz~928.00MHz (ZP3102JP-5)		
921.42MHz (ZP3102BR-5)		
Operating Range: Up to 100 feet line of sight		
Operating Temp.: -15°C~ 40°C (5°F~104°F)		
Battery: Panasonic CR123A * 1PC		

Z-Wave Command Classes:

COMMAND_CLASS_ASSOCIATION_GRP_INFO
 COMMAND_CLASS_ASSOCIATION_V2
 COMMAND_CLASS_BASIC
 COMMAND_CLASS_BATTERY
 COMMAND_CLASS_CONFIGURATION
 COMMAND_CLASS_DEVICE_RESET_LOCALLY
 COMMAND_CLASS_FIRMWARE_UPDATE_MD_V2
 COMMAND_CLASS_MANUFACTURER_SPECIFIC_V2
 COMMAND_CLASS_NOTIFICATION_V4 (mapping _COMMAND_CLASS_BASIC)
 COMMAND_CLASS_POWERLEVEL
 COMMAND_CLASS_SECURITY
 COMMAND_CLASS_SENSOR_MULTILEVEL_V5
 COMMAND_CLASS_VERSION_V2
 COMMAND_CLASS_WAKE_UP_V2
 COMMAND_CLASS_ZWAVEPLUS_INFO_V2

Installation

Notice: If you are installing the entire Z-Wave™ system for the first time, please refer to the installation guide of Z-Wave™ Interface Controller before installing ZP3102.

1. Release cover tab to open the cover and insert a CR123A battery into the battery compartment and LED will start to flash slowly, which means the sensor has not been "inclusion" yet.
2. Close the cover back to sensor.
3. **For "Inclusion (Auto-Inclusion)"** in (adding to) a network: To add the ZP3102 to your Z-Wave network (inclusion), place your Z-Wave primary controller into inclusion mode and the distance between sensor and controller is suggested to be in one meter. Press the Program Switch of ZP3102 for sending the NIF. After sending NIF, Z-Wave will send the auto inclusion, otherwise, ZP3102 will go to sleep after 10 seconds. (P.S.: Press the Program Switch to send NIF again for inclusion if the auto inclusion did not success. The ZP3102 will go to sleep after 20 seconds if the inclusion did not work).

For "Exclusion" from (removing from) a network: To remove the ZP3102 from your Z-Wave network (exclusion), place your Z-Wave primary controller into "exclusion" mode, and following its instruction to delete the ZP3102 to your controller. Press the Program Switch of ZP3102 once to be excluded. The LED on the ZP3102 should start to flash.

For "Association": removing the cover of the ZP3102 to get into "Awake" mode, then put the Z-Wave™ Interface Controller into "association", and following its instruction to associate the ZP3102 with other device. Close the cover back after "association" done, afterward the ZP3102 will get into "Sleep" mode for power saving. Support one association group (5 nodes).

4. **Awake Mode:**

It will be triggering after opening the front cover (refer Table 2), also the red LED will keep on lasting 10 seconds and ZP3102 will send "Wake Up Notification" after 10 seconds.

5. **Auto Wake Up:**

Use "Wake Up" command to set up the awaking time (from 10 minutes to 1 week) and send the wake up notification to controller

6. **Battery Capacity Detection:**

- * Use "Battery Get" command to have the battery capacity back in %
- * It will detect the battery capacity automatically
- * Low Battery Auto Report when power is lower than 2.6V +/- 0.1V

7. **Temperature Report:**

The user needs to get the controller for receiving the current temperature except when the temperature +2°C or -2°C degree then the sensor will automatically report to the controller. (ZP3102 will send the Multilevel Sensor Report to Controller)

8. **Configuration Command Class:**

	Byte	Value
Parameter 1	1	1 ~ 255 (unsigned decimal) Minutes (default: 3 minutes)
Parameter 2	1	0x00 (Celsius) / 0x01 (Fahrenheit) (default: 0x00)
Parameter 3	1	1 ~ 7 (default: 4)
Parameter 4	1	-10 ~ -1, 0 ~ 10 (signed decimal in Celsius) (0xF6~0xFF, 0x0~0xA, default: 0x00)

(Table 1)

(Parameter 1) Re-trigger duration: User can change value from 1 to 255 minutes to setup the re-trigger time when there is no movement detected in the period of time. Default is 3 minutes.

(Parameter 2) Celsius / Fahrenheit switching function.

(Parameter 3) Infrared sensor sensitivity adjustment, 7 levels sensitivity, 1 = most sensitive, 7 = most insensitive, default values= 4

(Parameter 4) User Defined Celsius Adjustment, for user's own choice

9. Using adhesive tape to mount ZP3102 at 2 meters above surface. To enhance proper operation, place ZP3102 on the angle which can detect the room widely. The solid area means the detector's coverage range.

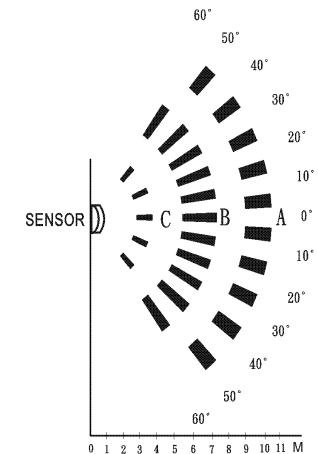
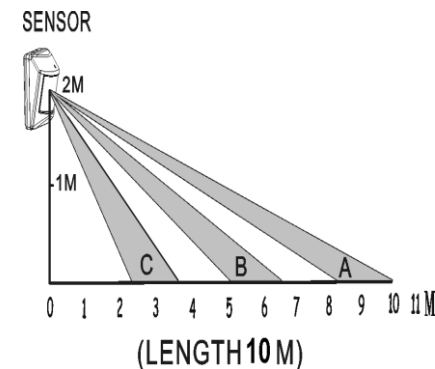

10. **Factory Default Reset:** Remove cover to triggered tamper switch, LED ON & send out Alarm Report. Press Program Switch 10 times within 10 seconds, ZP3102 will send the "Device Reset Locally Notification" command and reset to the factory default. (Remark: This is to be used only in the case of primary controller being inoperable or otherwise unavailable.)
11. All the rest commands depend on Z-Wave standard.

Operation

1. Walk in front of ZP3102, sensor will send Basic set On (0xFF), LED will flash once and please refer to status report as table below.
2. If no movement detected in three minutes (default is 3 minutes - based on user's configuration setting, refer Table 1, Parameter 1) will send Basic Set OFF (0x00), LED will flash once, and refer to table for status.
3. The ZP3102 sensor equipped with tamper switch. If the tamper switch is triggered (or remove the cover), the PIR sensor will send Alarm Report, LED will go solid, and refer to table for status.
4. If the tamper switch is closed (or closed the cover), ZP3102 will send Alarm Report, LED will go off, and refer to table for status.
5. Alarm report will not be send if there is no association set. Before closing the tamper switch (or closed the cover), the sensor is under "Awake" mode.

	Alarm V1 (Movement & Tamper Switch)	Notification V4 (Movement)	Notification V4 (Tamper Switch)
Alarm Type	0x07		
Alarm Level	0x00 (No movement after 3 mins) 0xFF (Motion detected)		
Notification Type		0x07	0x07
Notification Event		0x08(Motion Detected)/ 0x00 (no movement after 3 mins)	0x03(remove cover)/ 0x00 (cover closed)
Notification Parameter		0x08	0x03

(Table 2)

6. Support OTA Firmware update from controller. Please refer to your controller manual. Once OTA function success, please make sure to exclusive the device & inclusive again before use the device.

Federal Communications Commission Statement

This equipment has been followed to comply with the limits for a Class B digital device, pursuant to Part 15 of the FCC Rules. These limits are designed to provide reasonable protection against harmful interference in a residential installation. This equipment generates, uses and can radiate radio frequency energy and, if not installed and used in accordance with the instruction, may cause harmful interference to radio communications. However, there is no guarantee that interference will not occur in a particular installation. If this equipment does cause harmful interference to radio or television reception, which can be determined by turning the equipment off and on, the user is encouraged to try and correct the interference by one of the following measures:

- Reorient or relocate the receiving antenna,
- Increase the separation between the equipment and receiver,
- Connect the equipment into an outlet on a circuit different from that to which the receiver is connected.
- Consult the dealer or an experienced radio/TV technician for help.

This device complies with Part 15 of the FCC Rules. Operation is subject to the following two conditions: (1) this device may not cause harmful interference, and (2) this device must accept any interference received, including interference that may cause undesired operation.

FCC Caution: Any changes or modifications not expressly approved by the party responsible for compliance could void the user's authority to operate this equipment.

Limited Warranty

Vision Guarantees that every wireless PIR sensor is free from physical defects in material and workmanship under normal use for one year from the date of purchase. If the product proves defective during this one-year warranty period, Vision will replace it free of charge. Vision does not issue any refunds. This warranty is extended to the original end user purchase only and is not transferable. This warranty does not apply to: (1) damage to units caused by accident, dropping or abuse in handling, or any negligent use; (2) units which have been subject to unauthorized repair, taken apart, or otherwise modified; (3) units not used in accordance with instruction; (4) damages exceeding the cost of the product; (5) transit damage, initial installation costs, removal cost, or reinstallation cost.

For information on additional devices, please visit us at www.visionsecurity.com.tw

Industry Canada Notice

Operation is subject to the following two conditions: (1) this device may not cause interference and (2) this device must accept any interference, including interference that may cause undesired operation of the device.

Industry Canada Caution

This device complies with Industry Canada licence-exempt RSS standard(s).

Operation is subject to the following two conditions:

- (1) this device may not cause interference, and
- (2) this device must accept any interference, including interference that may cause undesired operation of the device.

Le présent appareil est conforme aux CNR d'IndustrieCanada applicables aux appareils radio exempts de licence. L'exploitation est autorisée aux deux conditions suivantes :

- (1) l'appareil ne doit pas produire de brouillage, et
- (2) l'utilisateur de l'appareil doit accepter tout brouillage radioélectrique subi, même si le brouillage est susceptible d'en compromettre le fonctionnement.