



Installation & Operation Manual

VAE 738

Wireless Rear View Camera System

VAE-738 V0	1030521	6B1K-73006
--------------	---------	------------



General Information

Thanks for purchasing Vision's Wireless Rear View Camera System. Vision's VAE 738 wireless rear view camera system is not only able to enhance your driving experience but also is designed to reduce the risk of collisions and other potential harm when the vehicle is reversing.

VAE-738 is using 2.4GHz digital transmission technology to transfer the rear view to your monitor when backing-up. Meanwhile, the system supports multi-channel which tune automatically to avoid the signal interference.

Declaration:

Vision's Wireless Rear View Camera System does not guarantee or promise that the user will not be in an accident or otherwise not collide with an object. Vision's Wireless Rear View Camera System is not intended for use as a substitute for rear-view mirror or for any other motor vehicle equipment required to be installed by law.

Package Contents

VAE 738 Wireless Rear View Camera System includes:

- 1PC * Transmitter
- 1PC * Receiver
- 1PC* Installation & Operation Manual
- 1Pack* Fitting Kit

Specification

Video system: NTSC/PAL (Auto detection)

Video input: 1.0 Vp-p 75Ω

Voltage: 9-32Vdc input

Current consumption TX: $\leq 300 \pm 20\text{mA} @ 12\text{V}$

Current consumption RX: $\leq 200 \pm 20\text{mA} @ 12\text{V}$

Digital Transmission: 2.4 GHz, SST 20 channel (FCC/CE)

Dimensions: 113.7(w) x 114.3(h) x 30.8(d) mm

Environmental TX: IP69

Environmental RX: No IP rating

Operating temp: $-40^{\circ}\text{C} \sim +85^{\circ}\text{C}$ ($-40^{\circ}\text{F} \sim +185^{\circ}\text{F}$)

Wiring Diagram

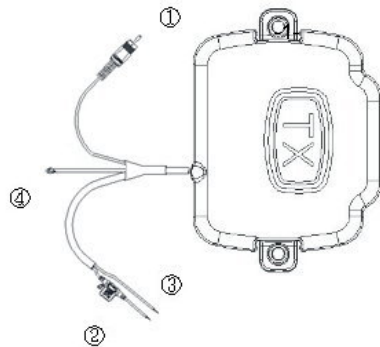

TX Transmitter Wire

1. RCA (Yellow) : Camera video connection
2. Red Wire: Power (Connect to reverse signal 12/24Vdc)
3. Black: wire Ground
4. Black/Red wire: Power supply for camera (optional)

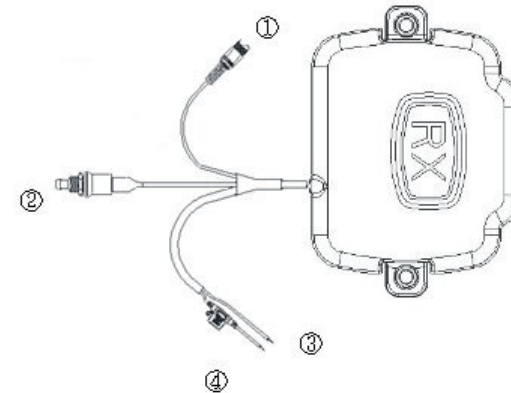

RX Receiver Wire

1. RCA (Yellow): Video out
2. Red Button: Pairing function button
3. Black Wire: Ground
4. Red Wire: Power (Connect to Reverse signal 12/24VDC)

Installation

Please read the instruction thoroughly prior to installation. Improper installation will void manufacturer's warranty. Please note that this package does not include monitor and camera. Follow the wiring diagram to complete all connection setup. Equipping RX receiver under dashboard with four screws and fixing TX transmitter in the end of trunk with four screws as well. When gear is put in reverse position, the transmitter will automatically power on.

Operation

When gear is in reverse position, monitor display rear view automatically which help drivers identify an object or a person behind a car and prevent damages from unwanted accidents.

Trouble Shooting

Pairing is not necessary as the unit has been paired by Vision before shipping, so under normal circumstance, customer can see rear view clearly after installation. When it malfunctions, there are number of ways to troubleshoot:

1. If user purchase new transmitter for instead of original one, then please try to pair the system by pressing "Red Button on transmitter for 2 seconds, the screen will show the system is in pair mode and start to countdown from 50 seconds.



Once rear view can be transferred to monitor which means user have completed pairing successfully.

2. If monitor shows "No Video Signal" or fails to display, user may check the wire to make sure the wire is connected correctly or camera is in good condition.
3. If monitor shows "No Signal", user may check whether the wires are connected correctly and make sure the camera is able to receive power from vehicle's electrical supply system. Or consumer can contact with customer service to check if any damage occurs.

Limited Warranty

Vision Guarantees that every **wireless door/window sensor** is free from physical defects in material and workmanship under normal use for one year from the date of purchase. If the product proves defective during this one-year warranty period, Vision will replace it free of charge. Vision does not issue any refunds. This warranty is extended to the original end user purchase only and is not transferable. This warranty does not apply to : (1) damage to units caused by accident, dropping or abuse in handling, or any negligent use; (2) units which have been subject to unauthorized repair, taken apart, or otherwise modified; (3) units not used in accordance with instruction; (4) damages exceeding the cost of the product; (5) transit damage, initial installation costs, removal cost, or reinstallation cost. For information on additional devices, please visit us at www.visionsecurity.com.tw

Federal Communication Commission Interference Statement

This equipment has been tested and found to comply with the limits for a Class B digital device, pursuant to Part 15 of the FCC Rules. These limits are designed to provide reasonable protection against harmful interference in a residential installation.

This equipment generates, uses and can radiate radio frequency energy and, if not installed and used in accordance with the instructions, may cause harmful interference to radio communications. However, there is no guarantee that interference will not occur in a particular installation. If this equipment does cause harmful interference to radio or television reception, which can be determined by turning the equipment off and on, the user is encouraged to try to correct the interference by one of the following measures:

- . Reorient or relocate the receiving antenna.
- . Increase the separation between the equipment and receiver.
- . Connect the equipment into an outlet on a circuit different from that to which the receiver is connected.
- . Consult the dealer or an experienced radio/TV technician for help.

FCC Caution: To assure continued compliance, any changes or modifications not expressly approved by the party responsible for compliance could void the user's authority to operate this equipment. (Example - use only shielded interface cables when connecting to computer or peripheral devices).

FCC Radiation Exposure Statement

This equipment complies with FCC RF radiation exposure limits set forth for an uncontrolled environment. This equipment should be installed and operated with a minimum distance of 20 centimeters between the radiator and your body.

This transmitter must not be co-located or operating in conjunction with any other antenna or transmitter.

The antennas used for this transmitter must be installed to provide a separation distance of at least 20 cm from all persons and must not be co-located or operating in conjunction with any other antenna or transmitter.

This device complies with Part 15 of the FCC Rules. Operation is subject to the following two conditions:

- (1) This device may not cause harmful interference, and
- (2) This device must accept any interference received, including interference that may cause undesired operation.