

**Radio Systems Corporation  
FCC Part 15, Certification Application  
Model RF-125**

**December 7, 2000**

# MEASUREMENT/TECHNICAL REPORT

COMPANY NAME: Radio Systems Corporation

MODEL: RF-125

FCC ID: KE3TXRF125

DATE: December 7, 2000

This report concerns (check one): Original grant  X   
Class II change  \_\_

---

Equipment type:  Low Frequency, Low Power Transmitter

---

Deferred grant requested per 47 CFR 0.457(d)(1)(ii)? yes  \_\_  No  X

If yes, defer until:  \_\_\_\_\_   
date

N.A.  agrees to notify the Commission by  NA   
date

of the intended date of announcement of the product so that the grant can be issued on that date.

---

Report prepared by:

United States Technologies, Inc.  
3505 Francis Circle  
Alpharetta, GA 30004

Phone Number: (770) 740-0717  
Fax Number: (770) 740-1508

## **TABLE OF CONTENTS**

### **AGENCY AGREEMENT**

#### **SECTION 1**

#### **GENERAL INFORMATION**

Product Description  
Related Submittal(s) Grant(s)

#### **SECTION 2**

#### **TESTS AND MEASUREMENTS**

Configuration of Tested  
Test Facility  
Test Equipment  
Modifications  
Field Strength of Fundamental Emission  
Field Strength of Spurious Emissions  
Radiated Emissions  
Power Line Conducted Emissions

#### **SECTION 3**

#### **LABELING INFORMATION**

#### **SECTION 4**

#### **BLOCK DIAGRAM/SCHEMATICS**

#### **SECTION 5**

#### **PHOTOGRAPHS**

#### **SECTION 6**

#### **USER'S MANUAL**

**LIST OF FIGURES AND TABLES**

**FIGURES**

Test Configuration  
Photograph(s) for Spurious and Fundamental Emissions

**TABLES**

EUT And Peripherals  
Test Instruments  
Field Strength of Fundamental Emission  
Field Strength of Spurious Emissions  
Power Line Conducted Emissions

SECTION 1  
GENERAL INFORMATION

## **GENERAL INFORMATION**

### **Product Description**

The Equipment Under Test (EUT) is a Radio Systems Corporation Low Frequency, Low Power PetSafe Deluxe Radio Fence Transmitter, Model RF125. The EUT consists of a 10.65 kHz dog fence transmitter. This report covers only the transmitter (dog fence) portion of the device.

### **Related Submittal(s) Grant(s)**

The EUT is subject to the following authorizations:

- a) Certification as a low power transmitter (10.65 kHz)

The information contained in this report is presented for the Certification authorization for the transmitter portion of the EUT.

SECTION 2  
TESTS AND MEASUREMENTS

## TESTS AND MEASUREMENTS

### Configuration of Tested System

The sample was tested per ANSI C63.4, Methods of Measurement from Low-Voltage Electrical and Electronic Equipment in the Range of 30 MHz -1 GHz (1992). Conducted and radiated emissions data were taken with the test receiver or spectrum analyzer's resolution bandwidth adjusted to 100 Hz (9 kHz – 150 kHz), 9kHz (150 kHz - 30 MHz), and 120 kHz (30 MHz - 1 GHz) respectively. All measurements are peak unless stated otherwise. The video filter associated with the spectrum analyzer was off throughout the evaluation process. Interconnecting cables were manipulated as necessary to maximize emissions. A block diagram of the tested system is shown in Figure 1. Test configuration photographs for spurious and fundamental emissions are shown in Figure 2.

The EUT was set up with a 320' length of wire connected to it, to simulate a typical installation. The wire was not buried, as it would be in a typical installation (approximately 2 -3 inches). Measurements were taken at all three antenna polarities on each side of the rectangle and intervals in between, at a distance of 3 meters. The side with the worst case results was re-measured at a distance of 10 meters. Results between 100 kHz and 30 MHz were corrected to 30 meters by the following  $40 \log (300/10) = 59.1$  dB. Those results below 100 kHz were corrected to 300 meters by the following  $60 \log (300/10) = 88.6$  dB (which has been applied to other submittals and is allowed per previous discussions with Greg Czumak at the FCC).

### Test Facility

Conducted and digital device testing was performed at US Tech's measurement facility as described to the FCC and acknowledged in their letter marked 31040/SIT/USTECH.

Additional radiated testing was performed at a vacant area that would allow measurements to be made 10 meters away from the EUT with the 320' length of wire connected to it.

### Test Equipment

Table 2 describes test equipment used to evaluate this product.

### Modifications

No modifications were made to bring the EUT into compliance with FCC Part 15, Class B Requirements:



**FIGURE 1**  
**TEST CONFIGURATION**

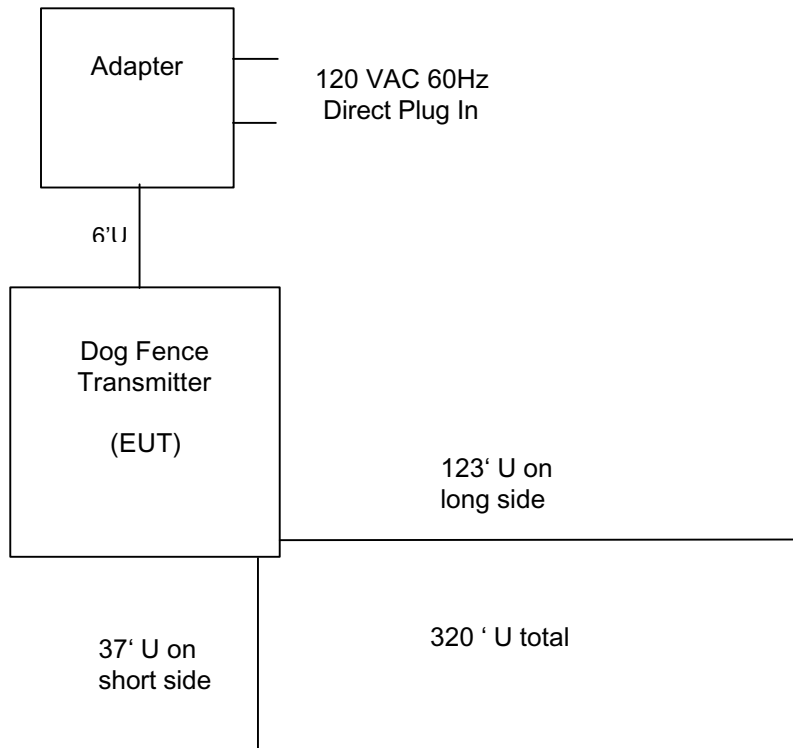

**FIGURE 2a**

**Photograph(s) for Spurious and Fundamental Emissions**



**FIGURE 2b**

**Photograph(s) for Spurious and Fundamental Emissions**

**(Photograph Shows 1<sup>st</sup> portion of testing at 3 meters)**



**Note: Personnel taking photograph normally monitored spectrum analyzer during test.**

**FIGURE 2c**

**Photograph(s) for Spurious and Fundamental Emissions**

**(Photograph Shows 1<sup>st</sup> portion of testing at 3 meters)**



**Note: Personnel taking photograph normally monitored spectrum analyzer during test.**

**FIGURE 2d**

**Photograph(s) for Spurious and Fundamental Emissions**

**(Photograph Shows 1<sup>st</sup> portion of testing at 3 meters)**



**Note: Personnel taking photograph normally monitored spectrum analyzer during test.**

**FIGURE 2e**

**Photograph(s) for Digital Device Emissions**



**FIGURE 2f**

**Photograph(s) for Digital Device Emissions**

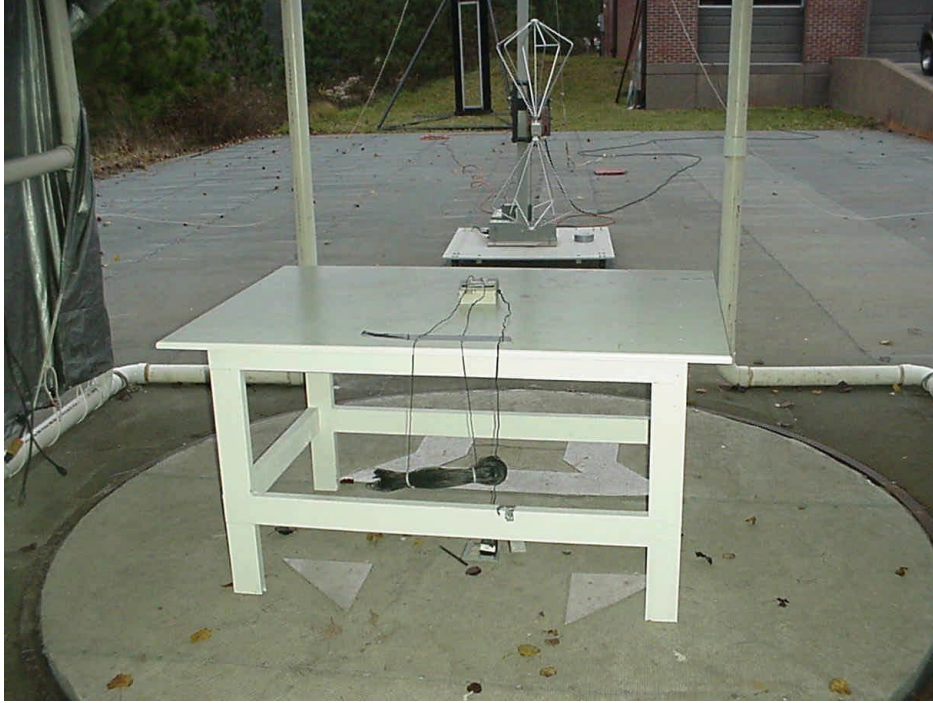

**FIGURE 2g**

**Photograph(s) for Conducted Emissions**





**EUT and Peripherals**

<b>PERIPHERAL MANUFACTURER</b>	<b>MODEL NUMBER</b>	<b>SERIAL NUMBER</b>	<b>FCC ID:</b>	<b>CABLES P/D</b>
Dog Fence Transmitter Radio Systems Corporation (EUT)	RF-125	None	KE3TXRF125 (pending)	320' U
Adapter Radio Systems Corporation	41A-12-830 P/N: 300-006	None	None	6' U

**TABLE 2**  
**TEST INSTRUMENTS**

<b>TYPE</b>	<b>MANUFACTURER</b>	<b>MODEL</b>	<b>SN.</b>
SPECTRUM ANALYZER	HEWLETT-PACKARD	8593E	3205A00124
SPECTRUM ANALYZER	HEWLETT-PACKARD	8558B	2332A09900
S A DISPLAY	HEWLETT-PACKARD	853A	2404A02387
COMB GENERATOR	HEWLETT-PACKARD	8406A	1632A01519
RF PREAMP	HEWLETT-PACKARD	8447D	1937A03355
RF PREAMP	HEWLETT-PACKARD	8449B	3008A00480
HORN ANTENNA	EMCO	3115	3723
BICONICAL ANTENNA	EMCO	3110	9307-1431
LOOP ANTENNA	AH SYSTEMS	SAS200/562	142
LOG PERIODIC ANTENNA	EMCO	3146	9110-3600
BILOG	CHASE	CBL6112A	2238
LISN	SOLAR ELE.	8028	N/A
THERMOMETER	FLUKE	52	5215250
MULTIMETER	FLUKE	85	53710469
FUNCTION GENERATOR	TEKTRONIX	CFG250	CFG250TW15059
PLOTTER	HEWLETT-PACKARD	7475A	2325A65394

### **Field Strength of Fundamental Emission (47 CFR 15.209)**

Measurements were made using a peak detector. Field strength of the peak fundamental emission is shown in Tables 3 and 4.

For purposes of this test, the EUT was set to a range control of 10 and the slide switch set to 'B'.

### **Duty Cycle Correction During 100 msec:**

The EUT has only one type of transmit cycle which consists of 20.5 ms of transmit time every 35.6 ms (57.6% Duty Cycle). Figure 3 shows the characteristics of the pulse train for this cycle.

Duty Cycle Correction =  $20 \log (0.576) = - 4.8 \text{ dB}$

FIGURE 3

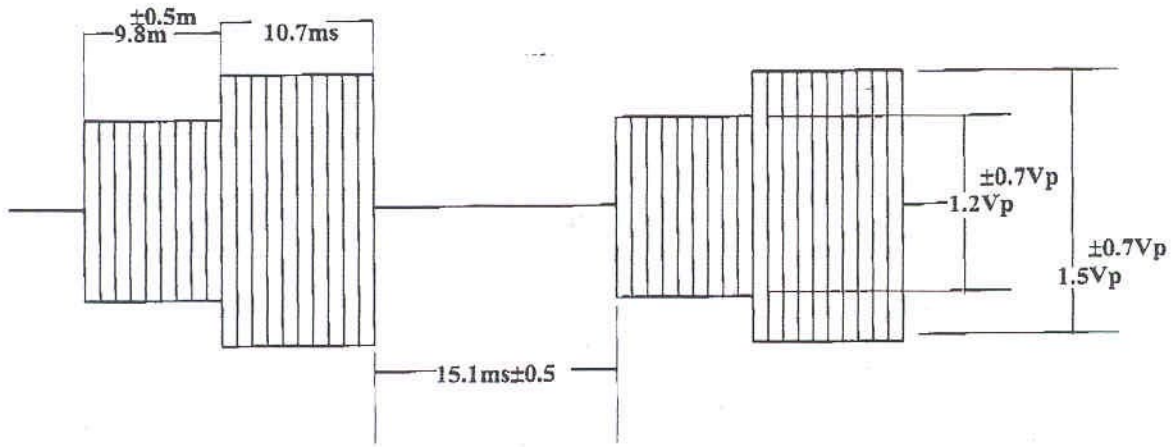

RF1010 and RF125 Output Signal  
Slide Switch Position "A"

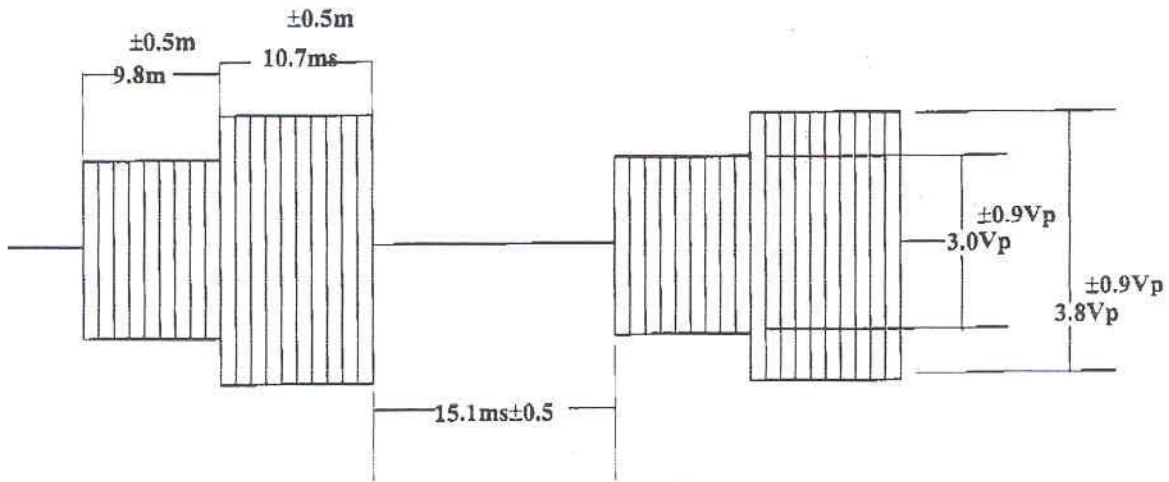

RF1010 and RF125 Output Signal  
Slide Switch Position "B"

**TABLE 3a**

**FIELD STRENGTH OF FUNDAMENTAL EMISSION**

**Test Date:** Novemeber 2, 2000  
**UST Project:** 00-0440  
**Customer:** Radio Systems Corporation  
**Model:** RF-125

FREQ. (kHz)	TEST DATA (dBm) @ 10m	ANTENNA FACTOR + CABLE ATTENUATION	PEAK RESULTS (uV/m) @ 300m	PEAK FCC LIMITS (uV/m) @ 300m
10.65	-76.7	78.2	9.9	2253.5

**SAMPLE CALCULATIONS:**

RESULTS uV/m @ 3m = Antilog  $((-76.7 + 78.2 + 107 - 88.6)/20)$  = 9.9

CONVERSION FROM dBm TO dBuV = 107 dB

CORRECTION FROM 10m TO 300m = -88.6 dB

**Tested By:** \_\_\_\_\_ **Name:** Austin E. Thompson, Jr.

**TABLE 3b**

**FIELD STRENGTH OF FUNDAMENTAL EMISSION**

**Test Date:** November 2, 2000  
**UST Project:** 00-0440  
**Customer:** Radio Systems Corporation  
**Model:** RF-125

FREQ. (kHz)	TEST DATA* (dBm) @ 10m	ANTENNA FACTOR + CABLE ATTENUATION	AVERAGE RESULTS (uV/m) @ 300m	AVERAGE FCC LIMITS (uV/m) @ 300m
10.65	-81.5	78.2	5.7	225.4

\* = Corrected for worse case duty cycle,  $20 \log (0.576) = -4.8 \text{ dB}$

**SAMPLE CALCULATIONS:**

RESULTS uV/m @ 3m =  $\text{Antilog} ((-81.5 + 78.2 + 107 - 88.6)/20) = 5.7$

CONVERSION FROM dBm TO dBuV = 107 dB

CORRECTION FROM 10m TO 300m = -88.6 dB

Tested By: \_\_\_\_\_ Name: Austin E. Thompson, Jr.

### **Field Strength Of Spurious Emissions (47 CFR 15.209)**

Measurements were made using a peak detector. Field strength of Spurious Emissions are shown in Table 4. For all emission measurements made the limits given in 15.209 were applied.

For purposes of this test, in order to yield the maximum field strength readings the EUT was set to a range control of 10 and the slide switch set to 'B'.

TABLE 4a

## FIELD STRENGTH OF SPURIOUS EMISSIONS

**Test Date:** November 2, 2000  
**UST Project:** 00-0440  
**Customer:** Radio Systems Corporation  
**Model:** RF-125

## Peak Readings (&lt; 30 MHz)

FREQ. (kHz.)	TEST DATA (dBm) @ 10m	ANTENNA FACTOR + CABLE ATTENUATION	PEAK RESULTS (uV/m) @ 300m	PEAK FCC LIMITS (uV/m) @ 300m
21.3	-78.1	71.2	3.8	1126.7
31.8	-83.6	68.9	1.5	754.7
42.6	-92.9	65.7	0.4	563.4

\*\* = Ground Floor

## SAMPLE CALCULATIONS:

RESULTS uV/m @ 3m = Antilog  $((-78.1 + 71.2 + 107 - 88.6)/20) = 3.8$

CONVERSION FROM dBm TO dBuV = 107 dB

CORRECTION FROM 10m TO 300m = -88.6 dB

Tested By: \_\_\_\_\_ Name: Austin E. Thompson Jr.



**TABLE 4b**

**FIELD STRENGTH OF SPURIOUS EMISSIONS**

**Test Date:** November 2, 2000  
**UST Project:** 00-0440  
**Customer:** Radio Systems Corporation  
**Model:** RF-125

**Average Readings (< 30 MHz)**

<b>FREQ. (kHz.)</b>	<b>TEST DATA* (dBm) @ 10m</b>	<b>ANTENNA FACTOR + CABLE ATTENUATION</b>	<b>AVERAGE RESULTS (uV/m) @ 300m</b>	<b>AVERAGE FCC LIMITS (uV/m) @ 300m</b>
21.3	-82.9	71.2	2.2	112.6
31.8	-88.4	68.9	0.9	75.5
42.6	-97.7	65.7	0.2	56.3

\* = Corrected for worse case duty cycle,  $20 \log(0.577) = -4.8 \text{ dB}$

**SAMPLE CALCULATIONS:**

**RESULTS uV/m @ 3m = Antilog  $((-82.9 + 71.9 + 107 - 88.6)/20) = 2.2$**   
**CONVERSION FROM dBm TO dBuV = 107 dB**  
**CORRECTION FROM 10m TO 300m = -88.6 dB**

**Tested By:** \_\_\_\_\_ **Name:** Austin E. Thompson, Jr.

**Radiated Emissions (47 CFR 15.109a)**

Radiated emissions were evaluated from 30 to 1000 MHz. Measurements were made with the analyzer's bandwidth set to 120 kHz. These results are shown Table 5.

**TABLE 5**

**FIELD STRENGTH OF SPURIOUS EMISSIONS (47 CFR 15.209)**

**CLASS B**

**Test Date:**            **October 31, 2000**  
**UST Project:**       **00-0440**  
**Customer:**           **Radio Systems Corporation**  
**Model:**               **RF-125**

**Digital Device Emissions actually tested while in TX Mode**

<b>Frequency (MHz)</b>	<b>Test Data (dBm) @3m</b>	<b>Ant. Factor + Cable Atten. - Amp Gain</b>	<b>Results (uV/m)</b>	<b>FCC Limits (uV/m) @3m</b>	<b>Margin Below FCC Limit (dB)</b>
----------------------------	------------------------------------	--	---------------------------	--------------------------------------	--

No emissions signals were seen from the EUT between the range of 30 MHz to 1 GHz

**Tested By:** \_\_\_\_\_ **Name:** Austin E. Thompson Jr.

**Power Line Conducted Emissions (47 CFR 15.107a)**

Conducted Emissions were evaluated from 450 kHz to 30 MHz. Measurements were made with the analyzer's bandwidth set to 9 kHz, emissions are shown in Table 6. The EUT was checked with a 320' fence length.

**TABLE 6 CONDUCTED EMISSIONS DATA****CLASS B**

**Test Date:** November 3, 2000  
**UST Project:** 00-0440  
**Customer:** Radio Systems Corporation  
**Model:** RF-125

FREQUENCY (MHz)	TEST DATA (dBm)		RESULTS (uV)		FCC LIMITS (uV)
	PHASE	NEUTRAL	PHASE	NEUTRAL	
0.45	-71.0	-79.0	63.1	25.1	250
9.6	-75.0	-77.0	39.8	31.6	250
11.7	-66.0	-72.0	112.2	56.2	250
11.8	-67.0	-74.0	100.0	44.7	250
13.7	-72.0	-79.0	56.2	25.1	250
13.8	-72.0	-78.0	56.2	28.2	250
15.3	-74.0	-76.0	44.7	35.5	250

**SAMPLE CALCULATIONS:**

**RESULTS uV = Antilog  $((-71.0 + 107)/20) = 63.1$**

**CONVERSION FROM dBm TO dBuV = 107 dB**

**Tested By:** \_\_\_\_\_ **Name:** Austin E. Thompson, Jr.