

DECLARATION OF CONFORMITY
On Behalf of
Radio Systems Corporation

Wireless Transmitter
Model No.:300-1070

Prepared for : Radio Systems Corporation
Address : 10427 Electric Ave., Knoxville, TN 37932 USA
Tel: +1 865-218-1557
Fax: +1 865-218-1557

Prepared By : Anbotek Compliance Laboratory Limited
Address : 1/F, 1 /Build, SEC Industrial Park, No. 4 Qianhai Road,
Nanshan District, Shenzhen, 518054, China
Tel: (86) 755-26014771
Fax: (86) 755-26014772

Report Number : 201012762F
Date of Test : Dec. 21~25, 2010
Date of Report : Dec. 29, 2010

TABLE OF CHONTENTS

Description

Page

Test Report Verification

1. GENERAL INFORMATION	4
1.1. Description of Device (EUT)	4
1.2. Description of Test Facility	5
1.3. Measurement Uncertainty	5
2. MEASURING DEVICE AND TEST EQUIPMENT	6
3. TEST PROCEDURE	7
4. POWER LINE CONDUCTED MEASUREMENT	8
4.1. Block Diagram of Test Setup	8
4.2. Power Line Conducted Emission Measurement Limits (FCC Part 15 15.207).....	8
4.3. Configuration of EUT on Measurement.....	8
4.4. Operating Condition of EUT.....	8
4.5. Test Procedure.....	9
4.6. Power Line Conducted Emission Measurement Results.....	9
5. RADIATED EMISSION MEASUREMENT.....	12
5.1. Radiated Emission Limits	12
5.2. Test Procedure.....	12
5.3. Test Setup.....	13
5.4. Test Results (Below 30MHz).....	14
5.5. Test Results (Between 30-1000MHz)	14
6. PHOTOGRAPH.....	17
6.1. Photo of Power Line Conducted Emission Test.....	17
6.2. Photo of Radiated Emission Test	17

TEST REPORT VERIFICATION

Applicant : Radio Systems Corporation
Manufacturer : Golden Regent Electronics Industrial Ltd.
EUT : Wireless Transmitter
Model No. : 300-1070
Rating : DC 24V via AC/DC Adapter
Trade Mark : PetSafe

Measurement Procedure Used:

FCC Rules and Regulations Part 15 Subpart C 15.207&15.209-2010 & FCC / ANSI C63.4-2009

The device described above is tested by Anbotek Compliance Laboratory Limited To determine the maximum emission levels emanating from the device. The maximum emission levels are compared to the FCC Part 15 Subpart C limits both radiated and conducted emissions. The measurement results are contained in this test report and Anbotek Compliance Laboratory Limited Is assumed full responsibility for the accuracy and completeness of these measurements. Also, this report shows that the Equipment Under Test (EUT) is to be technically compliant with the FCC requirements.

This report applies to above tested sample only. This report shall not be reproduced in part without written approval of Anbotek Compliance Laboratory Limited

Date of Test : Dec. 21~25, 2010

Prepared by : Well Wang
(Engineer/ Well Wang)

Reviewer : Coco Xiang
(Project Manager/ Coco Xiang)

Approved & Authorized Signer : Tom. Chen
(Manager/ Tom Chen)

1. GENERAL INFORMATION

1.1. Description of Device (EUT)

Description : Wireless Transmitter

Model Number : 300-1070

Test Power Supply : 120V~, 60Hz for Adapter

Adapter : SWITCH MODE POWER SUPPLY
Model No.: ITC-24V1.5C
Input: 100V-240V~, 50/60Hz, 1.0A max
Output: 24V $\overline{\text{---}}$ 1.5A
CE, FCC, C-TICK, ETL

Frequency : 18.7KHz

Applicant : Radio Systems Corporation
Address : 10427 Electric Ave., Knoxville, TN 37932 USA

Manufacturer : Golden Regent Electronics Industrial Ltd.
Address : Huangjinhu Management District, Qishi Town,
Dongguan City, Guangdong Province, China

Date of Sample received : Dec. 21, 2010

Date of Test : Dec. 21~25, 2010

1.2. Description of Test Facility

The test facility is recognized, certified, or accredited by the following organizations:

CNAS - LAB Code: L3503

Anbotek Compliance Laboratory Limited., Laboratory has been assessed and in compliance with CNAS/CL01: 2006 accreditation criteria for testing laboratories (identical to ISO/IEC 17025:2005 General Requirements) for the Competence of Testing Laboratories.

FCC-Registration No.: 752021

Anbotek Compliance Laboratory Limited, EMC Laboratory has been registered and fully described in a report filed with the (FCC) Federal Communications Commission. The acceptance letter from the FCC is maintained in our files. Registration 752021, August 20, 2010

IC-Registration No.: 8058A-1

Anbotek Compliance Laboratory Limited., EMC Laboratory has been registered and fully described in a report filed with the (IC) Industry Canada. The acceptance letter from the IC is maintained in our files. Registration 8058A-1, August 30, 2010

Test Location

All Emissions tests were performed
Anbotek Compliance Laboratory Limited. at 1/F, 1 /Build, SEC Industrial Park,
No. 4 Qianhai Road, Nanshan District, Shenzhen, 518054, China

1.3. Measurement Uncertainty

Radiation Uncertainty	:	Ur = 4.3dB
Conduction Uncertainty	:	Uc = 3.4dB

2. MEASURING DEVICE AND TEST EQUIPMENT

Equipment	Manufacturer	Model #	Serial #	Data of Cal.	Due Data
EMI Test Receiver	Rohde & Schwarz	ESCI	100119	Mar.03, 2010	Mar.02, 2011
EMI Test Receiver	Rohde & Schwarz	ESPI	1101604	Jun.21, 2010	Jun.20, 2011
EMI Test Receiver	Rohde & Schwarz	ESIB26	100249	Sep.22, 2010	Sep.21, 2011
EMI Test Software	SHURPLE	ESK1	N/A	N/A	N/A
Spectrum Analyzer	Agilent	E7405A	MY45114970	Jun.21, 2010	Jun.20, 2011
Signal Generator	Rohde & Schwarz	SMR27	100124	Jul.06, 2010	Jul.05, 2012
Signal Generator	Rohde & Schwarz	SML03	102319	Aug.01, 2010	Aug.01, 2012
AC Power Source	Sepcial power system	YF650	N/A	N/A	N/A
Absorbing Clamp	Rohde & Schwarz	MDS21	100218	Apr.30, 2010	Apr.29, 2012
Power Meter	Rohde & Schwarz	NRVD	101287	Jul.19, 2009	Jul.18, 2011
Coaxial Cable	N/A	N/A	N/A	May.31, 2010	May.30, 2011
Coaxial Cable	N/A	N/A	N/A	May.31, 2010	May.30, 2011
Coaxial Cable	N/A	N/A	N/A	May.31, 2010	May.30, 2011
Universal radio Communication tester	Rohde & Schwarz	CMU200	101724	Sep.08, 2009	Sep.07, 2011
Pulse Limiter	Rohde & Schwarz	ESH3-Z2	N/A	N/A	N/A
BiConilog Antenna	ETS-LINDGREN	3142C	00042670	Mar.03, 2010	Mar.02, 2011
BiConilog Antenna	ETS-LINDGREN	3142C	00042673	Mar.03, 2010	Mar.02, 2011
Loop Antenna	ETS-LINGREN	6502	00071730	Mar.03, 2010	Mar.02, 2011
Double-ridged Waveguide horn	ETS-LINDGREN	3117	00035926	Dec.30, 2009	Dec.29, 2011
Double-ridged Waveguide horn	ETS-LINDGREN	3117	00041545	Dec.30, 2009	Dec.29, 2011
Pre-amplifier	CD	PAM0203	804203	Jun.21, 2010	Jun.20, 2011
RF Switch	CD	RSU-M3	706543	Jun.21, 2010	Jun.20, 2011
Thermo-/Hygrometer	N/A	TH01	N/A	May.03, 2010	May.02, 2011
Shielding Room	Zhong Yu Electronic	N/A	N/A	N/A	N/A
3m Semi-Anechoic Chamber	Zhong Yu Electronic	N/A	N/A	Apr.28, 2010	Apr.27, 2012

3. Test Procedure

GENERAL: This report shall NOT be reproduced except in full without the written approval of Anbotek Compliance Laboratory Limited. The EUT was transmitting a test signal during the testing.

RADIATION INTERFERENCE: The test procedure used was ANSI STANDARD C63.4-2009 using a spectrum analyzer with a pre-selector. The analyzer was calibrated in dB above a microvolt at the output of the antenna. The resolution bandwidth was 100KHz and the video bandwidth was 300KHz up to 1.0GHz and 1.0MHz with a video BW of 3.0MHz above 1.0GHz. The ambient temperature of the EUT was 74.3oF with a humidity of 69%.

FORMULA OF CONVERSION FACTORS: The Field Strength at 3m was established by adding the meter reading of the spectrum analyzer (which is set to read in units of dBuV) to the antenna correction factor supplied by the antenna manufacturer. The antenna correction factors are stated in terms of dB. The gain of the Preselector was accounted for in the Spectrum Analyzer Meter Reading.

Example:

Freq (MHz) METER READING + ACF = FS
33 20 dBuV + 10.36 dB = 30.36 dBuV/m @ 3m

ANSI STANDARD C63.4-2009 10.1.7 MEASUREMENT PROCEDURES: The EUT was placed on a table 80 cm high and with dimensions of 1m by 1.5m. The EUT was placed in the center of the table (1.5m side). The table used for radiated measurements is capable of continuous rotation.

When an emission was found, the table was rotated to produce the maximum signal strength. At this point, the antenna was raised and lowered from 1m to 4m. The antenna was placed in both the horizontal and vertical planes.

4. POWER LINE CONDUCTED MEASUREMENT

4.1. Block Diagram of Test Setup

4.1.1. Block diagram of connection between the EUT and simulators

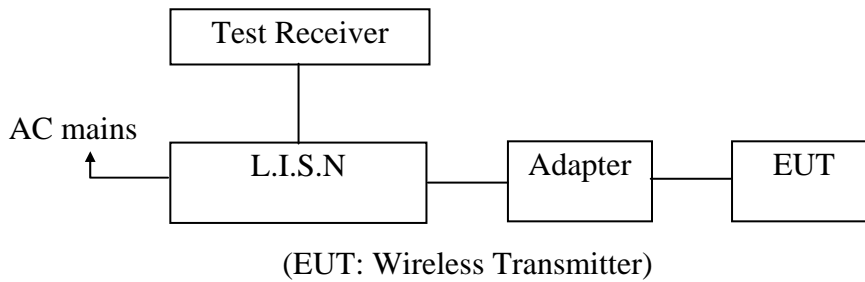

4.2. Power Line Conducted Emission Measurement Limits (FCC Part 15

15.207)

Frequency MHz	Limits dB(μV)	
	Quasi-peak Level	Average Level
0.15 ~ 0.50	66 ~ 56*	56 ~ 46*
0.50 ~ 5.00	56	46
5.00 ~ 30.00	60	50

- Notes: 1. *Decreasing linearly with logarithm of frequency.
 2. The lower limit shall apply at the transition frequencies.

4.3. Configuration of EUT on Measurement

The following equipments are installed on Power Line Conducted Emission Measurement to meet the commission requirement and operating regulations in a manner which tends to maximize its emission characteristics in a normal application.

EUT : Wireless Transmitter
 Model Number : 300-1070
 Applicant : Radio Systems Corporation

4.4. Operating Condition of EUT

- 4.4.1. Setup the EUT and simulator as shown as Section 4.1.
- 4.4.2. Turn on the power of all equipment.
- 4.4.3. Let the EUT work in test mode (ON) and measure it.

4.5. Test Procedure

The EUT system is connected to the power mains through a line impedance stabilization network (L.I.S.N.). This provides a 50ohm coupling impedance for the EUT system. Please refer the block diagram of the test setup and photographs. Both sides of AC line are checked to find out the maximum conducted emission. In order to find the maximum emission levels, the relative positions of equipment and all of the interface cables shall be changed according to FCC ANSI C63.4-2009 on Conducted Emission Measurement.

The bandwidth of test receiver (ESCI) set at 9KHz.

The frequency range from 150KHz to 30MHz is checked.

The test result are reported on Section 4.6.

4.6. Power Line Conducted Emission Measurement Results

PASS.

The frequency range from 150KHz to 30 MHz is investigated.

The test curves are shown in the following pages.

CONDUCTED EMISSION TEST DATA

EUT: Wireless Transmitter M/N: 300-1070
 Operating Condition: ON
 Test Site: 1# Shielded Room
 Operator: Well. Wang
 Test Specification: 120V~, 60Hz for Adapter
 Comment: Live Line
 Tem:22.2 Hum:60%

SCAN TABLE: "Voltage (150K~30M) FIN"

Short Description: 150K-30M Disturbance Voltages

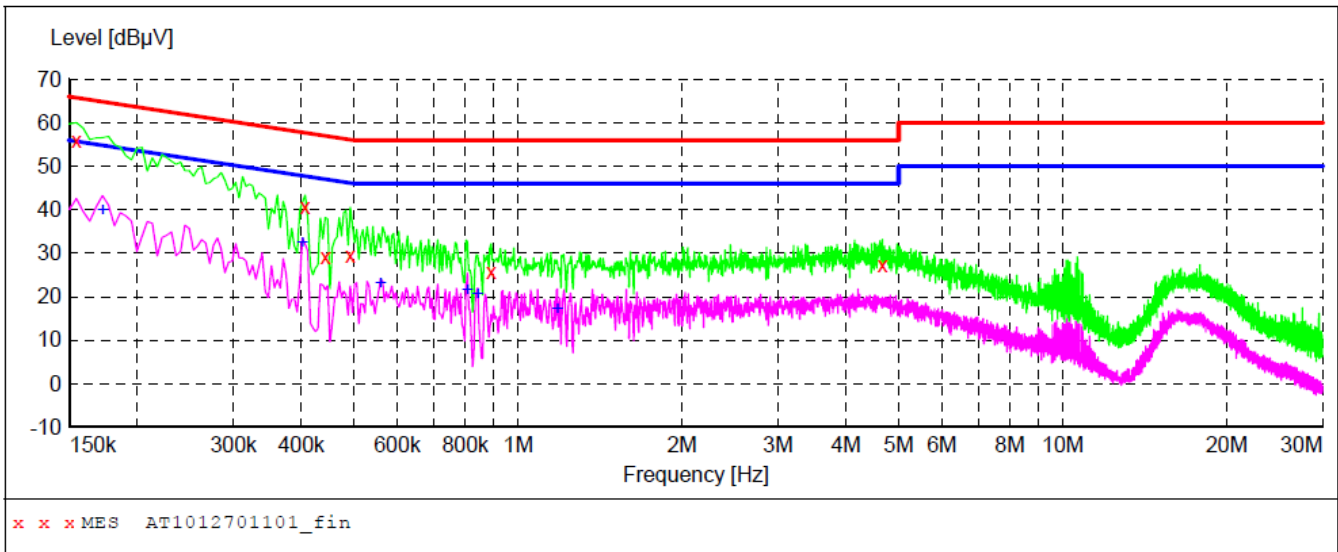

MEASUREMENT RESULT: "AT1012701101_fin"

12/21/2010 6:49PM

Frequency MHz	Level dBµV	Transd dB	Limit dBµV	Margin dB	Detector	Line	PE
0.154500	55.90	11.3	66	9.9	QP	L1	GND
0.406500	40.80	10.1	58	16.9	QP	L1	GND
0.442500	29.10	10.0	57	27.9	QP	L1	GND
0.492000	29.50	10.0	56	26.6	QP	L1	GND
0.892500	25.70	9.9	56	30.3	QP	L1	GND
4.668000	27.20	9.8	56	28.8	QP	L1	GND

MEASUREMENT RESULT: "AT1012701101_fin2"

12/21/2010 6:49PM

Frequency MHz	Level dBµV	Transd dB	Limit dBµV	Margin dB	Detector	Line	PE
0.172500	39.90	10.9	55	14.9	AV	L1	GND
0.402000	32.60	10.1	48	15.2	AV	L1	GND
0.559500	23.30	9.9	46	22.7	AV	L1	GND
0.807000	21.80	9.9	46	24.2	AV	L1	GND
0.843000	20.60	9.9	46	25.4	AV	L1	GND
1.180500	17.20	9.9	46	28.8	AV	L1	GND

CONDUCTED EMISSION TEST DATA

EUT: Wireless Transmitter M/N: 300-1070
 Operating Condition: ON
 Test Site: 1# Shielded Room
 Operator: Well. Wang
 Test Specification: 120V~, 60Hz for Adapter
 Comment: Neutral Line
 Tem:22.2 Hum:60%

SCAN TABLE: "Voltage (150K~30M) FIN"
 Short Description: 150K-30M Disturbance Voltages

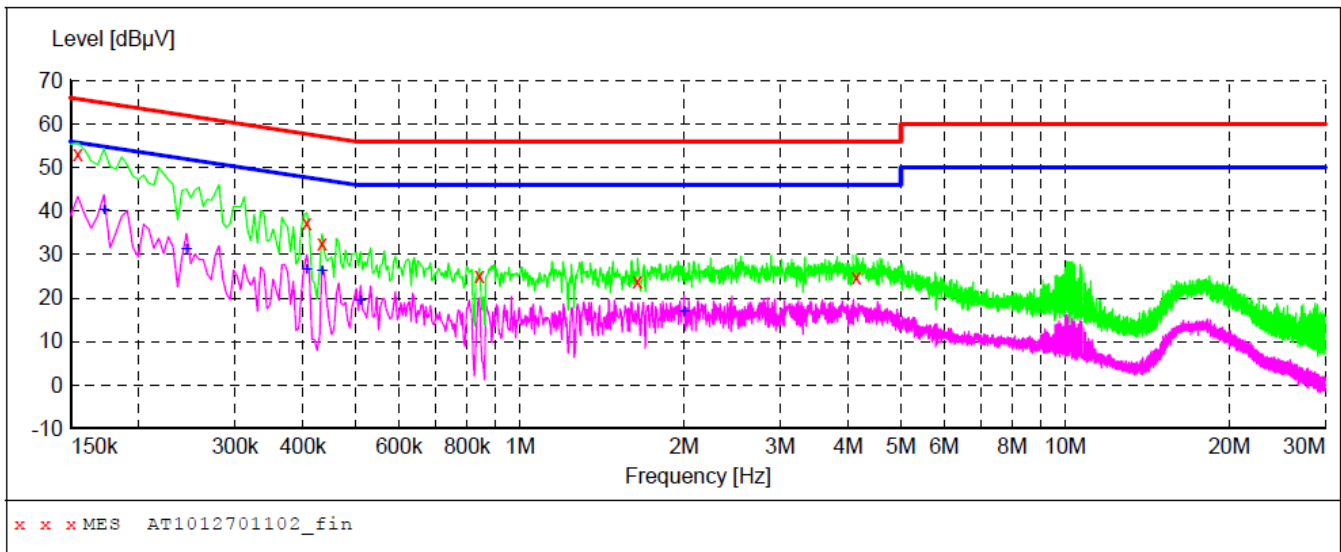

MEASUREMENT RESULT: "AT1012701102_fin"

12/21/2010 6:53PM

Frequency MHz	Level dBµV	Transd dB	Limit dBµV	Margin dB	Detector	Line	PE
0.154500	53.00	11.3	66	12.8	QP	N	GND
0.406500	37.20	10.1	58	20.5	QP	N	GND
0.433500	32.70	10.0	57	24.5	QP	N	GND
0.843000	25.00	9.9	56	31.0	QP	N	GND
1.644000	23.80	9.9	56	32.2	QP	N	GND
4.137000	24.70	9.8	56	31.3	QP	N	GND

MEASUREMENT RESULT: "AT1012701102_fin2"

12/21/2010 6:53PM

Frequency MHz	Level dBµV	Transd dB	Limit dBµV	Margin dB	Detector	Line	PE
0.172500	40.40	10.9	55	14.4	AV	N	GND
0.244500	31.40	10.4	52	20.5	AV	N	GND
0.406500	26.70	10.1	48	21.0	AV	N	GND
0.433500	26.40	10.0	47	20.8	AV	N	GND
0.510000	19.50	9.9	46	26.5	AV	N	GND
1.999500	16.90	9.9	46	29.1	AV	N	GND

5. RADIATED EMISSION MEASUREMENT

5.1. Radiated Emission Limits

Frequency (MHz)	Field Strength Limitation		Field Strength Limitation at 3m Measurement Dist	
	(uV/m)	Dist	(uV/m)	(dBuV/m)
0.009 – 0.490	2400 / F(KHz)	300m	10000 * 2400/F(KHz)	20log 2400/F(KHz) + 80
0.490 – 1.705	24000 / F(KHz)	30m	100 * 24000/F(KHz)	20log 24000/F(KHz) + 40
1.705 – 30.00	30	30m	100* 30	20log 30 + 40
30.0 – 88.0	100	3m	100	20log 100
88.0 – 216.0	150	3m	150	20log 150
216.0 – 960.0	200	3m	200	20log 200
Above 960.0	500	3m	500	20log 500

Note:

- (1) The tighter limit shall apply at the boundary between two frequency range.
- (2) Limitation expressed in dBuV/m is calculated by 20log Emission Level (uV/m).
- (3) If measurement is made at 3m distance, then F.S Limitation at 3m distance is adjusted by using the formula of $Ld1 = Ld2 * (d2/d1)^2$.

Example:

F.S Limit at 30m distance is 30uV/m , then F.S Limitation at 3m distance is adjusted as

$$Ld1 = L1 = 30uV/m * (10)^2 = 100 * 30 uV/m$$

5.2. Test Procedure

- a. The measuring distance of at 3 m shall be used for measurements at frequency up to 1GHz. For frequencies above 1GHz, any suitable measuring distance may be used.
- b. The EUT was placed on the top of a rotating table 0.8 meters above the ground at a 3m meter open area test site. The table was rotated 360 degrees to determine the position of the highest radiation.
- c. The height of the equipment or of the substitution antenna shall be 0.8 m; the height of the test antenna shall vary between 1 m to 4 m. Both horizontal and vertical polarizations of the antenna are set to make the measurement.
- d. The initial step in collecting conducted emission data is a spectrum analyzer peak detector mode pre-scanning the measurement frequency range. Significant peaks are then marked and then Quasi Peak detector mode re-measured.
- e. If the Peak Mode measured value compliance with and lower than Quasi Peak Mode Limit, the EUT shall be deemed to meet QP Limits and then no additional QP Mode measurement performed.
- f. For the actual test configuration, please refer to the related Item –EUT Test Photos.

5.3. Test Setup

(A) Radiated Emission Test Set-Up, Frequency below 30MHz

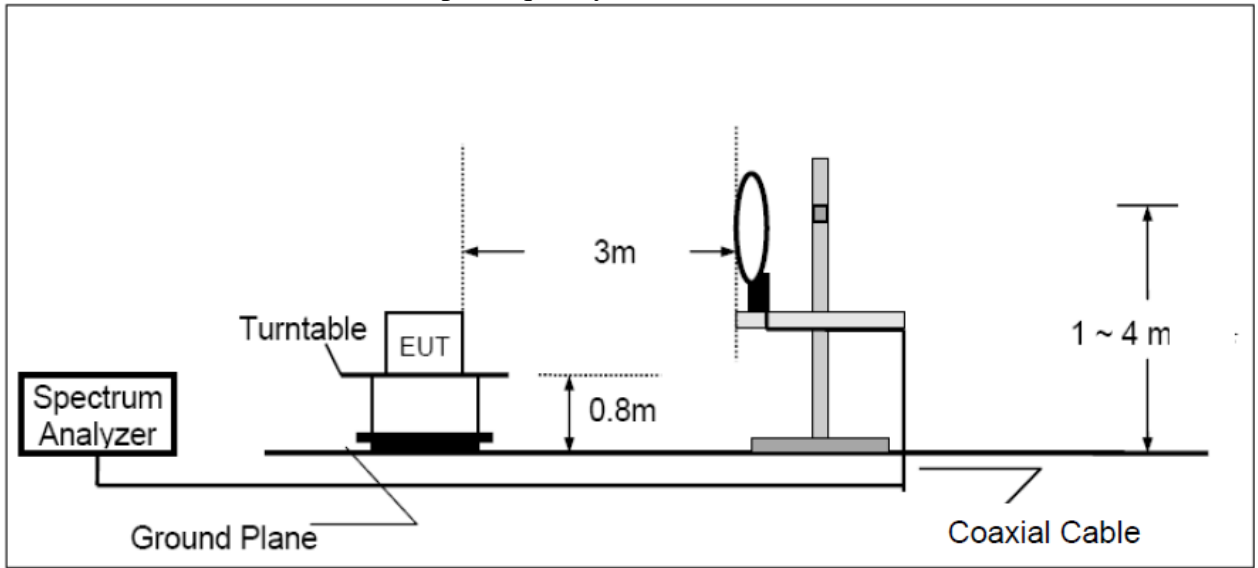

(B) Radiated Emission Test Set-Up, Frequency 30-1000MHz

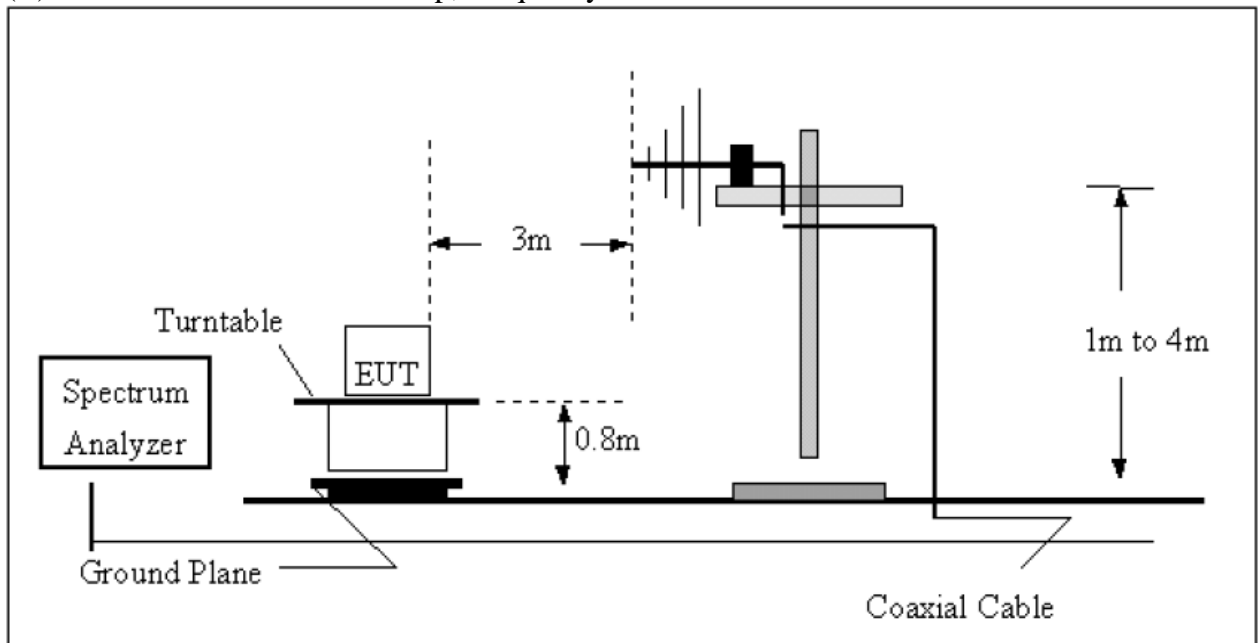

5.4. Test Results (Below 30MHz)

Freq.(KHz)	Reading at 3m (dBuV/m)	Factor (dB) Cable loss	Field Strength Limit (uV/m)	Required Measurement Distance (m)	Limitation Converted 3m dist. (dBuV/m)	Over Limit (dB)	Detector (PK/AV)
18.70	93.58	16.00	128.34	300.00	122.17	-12.59	PK
37.40	83.56	15.60	64.17	300.00	116.15	-16.99	PK
56.10	79.50	15.30	42.78	300.00	112.62	-17.82	PK
74.80	75.45	14.80	32.09	300.00	110.13	-19.88	PK
93.50	72.65	14.50	25.67	300.00	108.19	-21.04	PK
112.20	70.57	13.95	21.39	300.00	106.60	-22.08	PK
130.90	--	--	--	--	--	--	--
149.60	--	--	--	--	--	--	--
168.30	--	--	--	--	--	--	--
187.00	--	--	--	--	--	--	--

Remark:

(1) Spectrum Setting:

9 KHz – 150 KHz, RBW= 1 KHz, VBW=1 KHz, Sweep time = 200 ms.

150 K Hz – 30 MHz, RBW= 9 KHz, VBW=9 KHz, Sweep time = 200 ms.

- (2) All readings are Peak unless otherwise stated QP in column of 『Note』 . Peak denotes that the Peak reading compliance with the QP Limits and then QP Mode measurement didn't perform.
- (3) The Log-Bicon Antenna will use to test frequency range from 30MHz to 1000MHz and the Loop Antenna will use to test frequency below 30MHz.
- (4) If the peak scan value lower limit more than 20dB, then this signal data does not show in table

5.5. Test Results (Between 30-1000MHz)

PASS.

The test curves are shown in the following pages.



Anbotek Compliance Laboratory Limited

1/F, 1 /Building, SEC Industrial Park, No.4 Qianhai Road,
Nanshan District, Shenzhen, 518054, China

Tel: (86)755-26014771
Fax: (86)755-26014772
Http://www.anbotek.com

Job No.:	AT10126702F	Polarziation:	Horizontal
Standard:	(RE)FCC PART15 C _3m	Power Source:	120V~, 60Hz
Test item:	Radiation Test	Date:	2010/12/23
Temp.(C)/Hum.(%RH):	24.3(C)/55%RH	Time:	13:07:19
EUT:	Wireless Transmitter	Test By:	Well Wang
Model:	300-1070	Distance:	3m
Note:	ON		

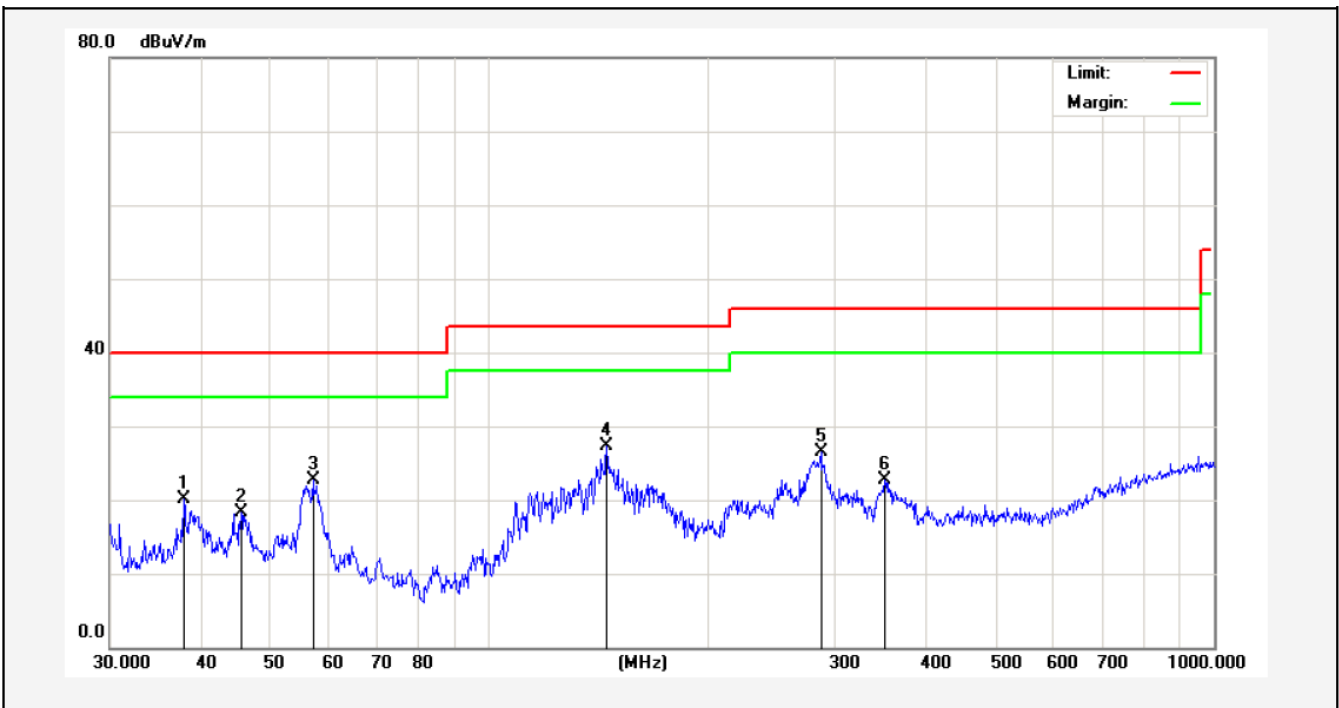

No.	Freq. (MHz)	Reading (dBuV/m)	Factor (dB/m)	Result (dBuV/m)	Limit (dBuV/)	Over Limit (dB)	Detector	Remark
1	37.9450	45.53	-25.40	20.13	40.00	-19.87	peak	
2	45.5348	43.05	-24.75	18.30	40.00	-21.70	peak	
3	57.1914	47.86	-25.25	22.61	40.00	-17.39	peak	
4	145.3506	59.40	-32.06	27.34	43.50	-16.16	peak	
5	286.9823	52.95	-26.53	26.42	46.00	-19.58	peak	
6	351.7079	45.10	-22.46	22.64	46.00	-23.36	peak	



Anbotek Compliance Laboratory Limited

1/F, 1 /Building, SEC Industrial Park, No.4 Qianhai Road,
Nanshan District, Shenzhen, 518054, China

Tel: (86)755-26014771
Fax: (86)755-26014772
Http://www.anbotek.com

Job No.:	AT10126702F	Polarziation:	Vertical
Standard:	(RE)FCC PART15 C _3m	Power Source:	120V~, 60Hz
Test item:	Radiation Test	Date:	2010/12/23
Temp.(C)/Hum.(%RH):	24.3(C)/55%RH	Time:	13:04:15
EUT:	Wireless Transmitter	Test By:	Well Wang
Model:	300-1070	Distance:	3m
Note:	ON		

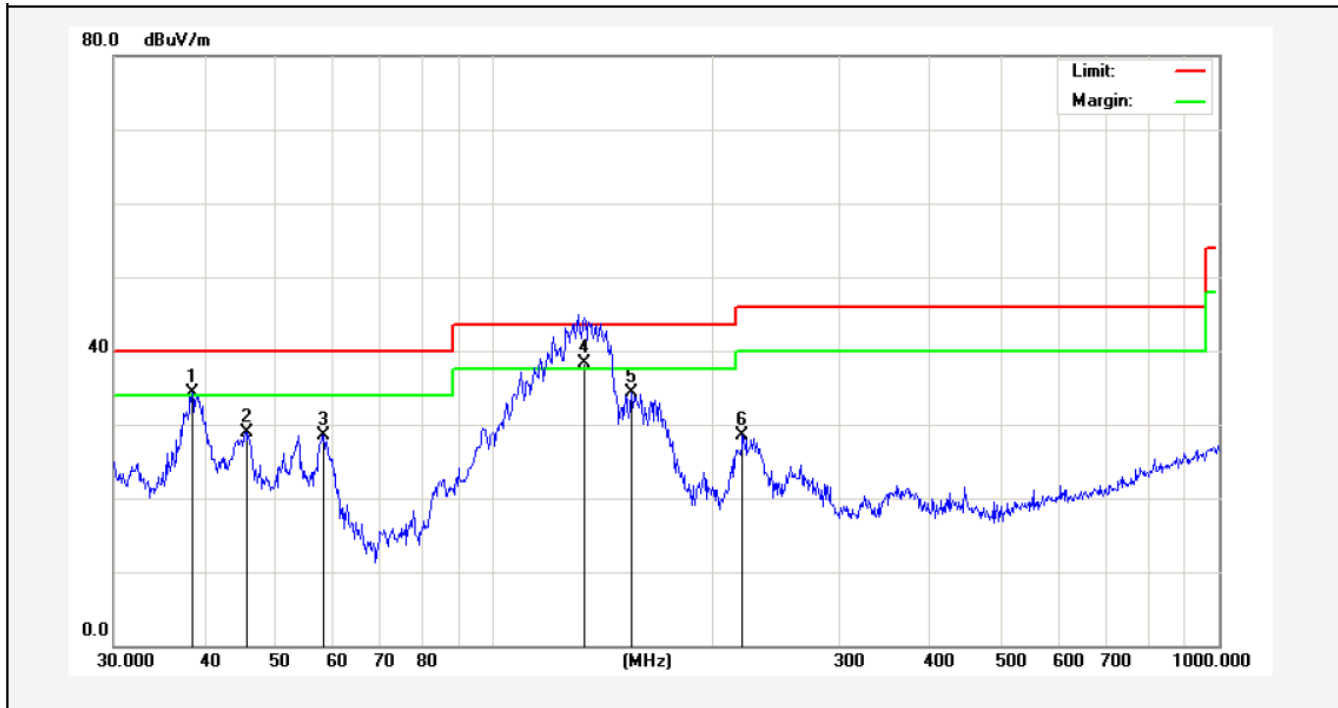

No.	Freq. (MHz)	Reading (dBuV/m)	Factor (dB/m)	Result (dBuV/m)	Limit (dBuV/)	Over Limit (dB)	Detector	Remark
1	38.4809	59.64	-25.25	34.39	40.00	-5.61	peak	
2	45.6948	53.73	-24.76	28.97	40.00	-11.03	peak	
3	58.4074	53.90	-25.33	28.57	40.00	-11.43	peak	
4	133.3769	65.10	-26.71	38.39	43.50	-5.11	QP	
5	154.8204	61.00	-26.73	34.27	43.50	-9.23	peak	
6	220.6171	52.17	-23.59	28.58	46.00	-17.42	peak	