



HERMON LABORATORIES



ELECTRICAL TESTING  
0839.01

Hermon Laboratories Ltd.  
P.O. Box 23, Binyamina 3055001, Israel  
Tel. +972 4628 8001  
Fax. +972 4628 8277  
E-mail: mail@hermonlabs.com

## TEST REPORT

ACCORDING TO:

FCC 47CFR part 15 subpart C § 15.209 and subpart B,  
RSS-210 issue 10 section 7.2, RSS-Gen issue 5, ICES-003 Issue 7:2020

FOR:

**Paradox Security Systems Ltd.**

**Proximity Reader**

**Model: R915**

**FCC ID: KDYR915**

**IC: 2438A-R915**

This report is in conformity with ISO/IEC 17025. The "A2LA Accredited" symbol endorsement applies only to the tests and calibrations that are listed in the scope of Hermon Laboratories accreditation. The test results relate only to the items tested.  
This test report shall not be reproduced in any form except in full with the written approval of Hermon Laboratories Ltd.



## Table of contents

1	Applicant information .....	3
2	Equipment under test attributes .....	3
3	Manufacturer information .....	3
4	Test details .....	3
5	Tests summary .....	4
6	EUT description .....	5
6.1	General information .....	5
6.2	Ports and lines .....	5
6.3	Operating frequencies .....	5
6.4	Support equipment .....	5
6.5	Test configuration .....	5
6.6	Transmitter characteristics .....	6
7	Transmitter tests according to 47CFR part 15 subpart C and RSS-210 requirements .....	7
7.1	Field strength of emissions .....	7
7.2	Occupied bandwidth test .....	15
8	Unintentional emissions .....	18
8.1	Conducted emissions .....	18
8.2	Radiated emission measurements .....	23
9	APPENDIX A Test equipment and ancillaries used for tests .....	26
10	APPENDIX B Test equipment correction factors .....	27
11	APPENDIX C Measurement uncertainties .....	29
12	APPENDIX D Test laboratory description .....	30
13	APPENDIX E Specification references .....	31
14	APPENDIX F Abbreviations and acronyms .....	32



## 1 Applicant information

**Client name:** Paradox Security Systems LTD.  
**Address:** 780 Industrial Boulevard St.Eustache, Quebec J7R 5V3 Canada  
**Telephone:** 450-491-7444  
**Fax:** 450-497-1095  
**E-mail:** [alexc@paradox.com](mailto:alexc@paradox.com)  
**Contact name:** Mr. Alex Chaplik

## 2 Equipment under test attributes

**Trade Mark:** P ▲ R ▲ D O X™  
**Product name:** Proximity Reader  
**Product type:** Transceiver  
**Model:** R915  
**Hardware version:** 671-2122-050  
**Software release:** V5.01  
**Receipt date:** 08-Mar-23

## 3 Manufacturer information

**Manufacturer name:** Paradox Security Systems LTD.  
**Address:** 780 Industrial Boulevard St.Eustache, Quebec J7R 5V3 Canada  
**Telephone:** 450-491-7444  
**Fax:** 450-497-1095  
**E-Mail:** [alexc@paradox.com](mailto:alexc@paradox.com)  
**Contact name:** Mr. Alex Chaplik

## 4 Test details

**Project ID:** 49765  
**Location:** Hermon Laboratories Ltd. P.O. Box 23, Binyamina 3055001, Israel  
**Test started:** 16-Mar-23  
**Test completed:** 23-Mar-23  
**Test specification(s):** FCC 47CFR part 15 subpart C § 15.209 and subpart B,  
RSS-210 issue 10 section 7.2, RSS-Gen issue 5, ICES-003 Issue 7:2020



## 5 Tests summary

Test	Status
<b>Transmitter characteristics</b>	
Section 15.209, / RSS-Gen, Section 6.5, 6.6 Field strength of emissions	Pass
Section 15.215 / RSS-Gen, Section 6.7, Occupied bandwidth	Pass
Section 15.203 / RSS Gen Section 6.8, Antenna requirements	Pass
<b>Unintentional emissions</b>	
FCC section n 15.107/ICES-003, Section 6.1, Class B, Conducted emission	Pass
FCC section 15.109/ICES-003, Section 6.2, Class B, Radiated emission	Pass

This test report supersedes the previously issued test report identified by Doc ID: PARRAD\_FCC.49767\_49765

Testing was completed against all relevant requirements of the test standard. However, results obtained indicate that the product under test complies in full with the requirements tested.  
The test results relate only to the items tested. Pass/ fail decision was based on nominal values.

	Name and Title	Date	Signature
<b>Tested by:</b>	Mrs. M. Evsuk, test engineer, EMC & Radio	16-Mar-23 – 23-Mar-23	
<b>Reviewed by:</b>	Mrs. S. Peysahov Sheynin, certification specialist, EMC & Radio	08-Oct-23	
<b>Approved by:</b>	Mr. M. Nikishin, group leader, EMC & Radio	08-Oct-23	



## 6 EUT description

Note: The following data in this clause is provided by the customer and represents his sole responsibility

### 6.1 General information

The EUTs, R915 is a proximity reader that intended to open gates by Card approximation. The EUTs are powered by external dedicated certified approved Paradox control panel which provide 11-14.5 VDC / 600 mA max. R915 proximity reader includes 12-button keypad.

### 6.2 Ports and lines

Port type	Port description	Connected		Qty.	Cable type	Cable length	Indoor / outdoor
		From	To				
Power	AC power	Access control module	AC mains	1	Unshielded	2 m	Indoor
Power & signal	BUS (RED, BLK, GRN, YEL)	EUT	Access control module	4	Unshielded	3 m*	Indoor

\* Always shorter than 30 m.

### 6.3 Operating frequencies

Source	Frequency, MHz					
RFID	0.125	---	---	---	---	---

### 6.4 Support equipment

Description	Manufacturer	Model number	Serial number
Access control module for R915	Paradox	ACM-12	181C0463

### 6.5 Test configuration

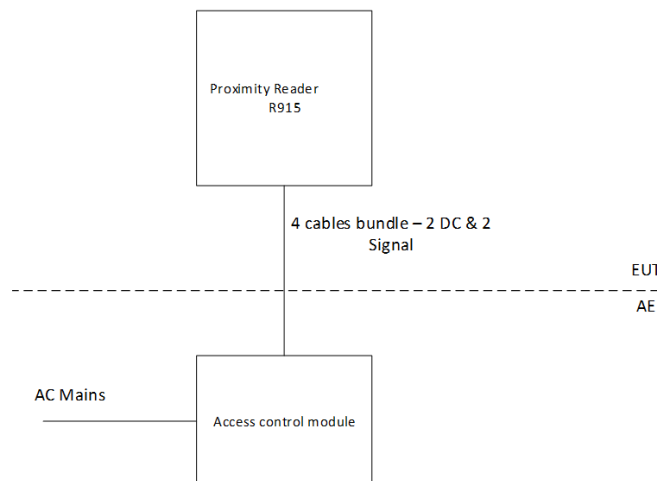



### 6.6 Transmitter characteristics

<b>Type of equipment</b>					
V	Stand-alone (Equipment with or without its own control provisions)				
	Combined equipment (Equipment where the radio part is fully integrated within another type of equipment)				
	Plug-in card (Equipment intended for a variety of host systems)				
<b>Intended use</b>		<b>Condition of use</b>			
<b>Permitted range of operating frequencies</b>		119 – 135 MHz			
<b>Operating frequency range</b>		125.65 kHz			
<b>RF channel spacing</b>		NA			
<b>Maximum H-field strength</b>		81.73 dB( $\mu$ V/m) Peak *			
<b>Maximum RF carrier current</b>		NA			
<b>Maximum E-field strength</b>		NA			
<b>Is transmitter output power variable?</b>		V	No		
		Yes	continuous variable		
			stepped variable with stepsize		
			dB		
<b>Antenna connection</b>					
unique coupling		standard connector		integral	
				with temporary RF connector	
				without temporary RF connector	
<b>Antenna/s technical characteristics</b>					
<b>Type</b>		<b>Model</b>		<b>Loop antenna area, m<sup>2</sup></b>	
Integral		R915 - PCB trace antenna		R915 (7.5cm x 2.7 cm)	
				Gain	
				NA	
<b>Product class</b>					
V	1				
	2				
	3				
	4				
<b>Type of modulation</b>		ASK			
<b>Modulating test signal (baseband)</b>		NA			
<b>Maximum transmitter duty cycle in normal use</b>		100 %	<b>Tx ON time</b>	msec	<b>Period</b>
<b>Transmitter duty cycle supplied for test</b>		100 %	<b>Tx ON time</b>	msec	<b>Period</b>
<b>Transmitter power source</b>					
	Battery	<b>Nominal rated voltage</b>	VDC		
	DC	<b>Nominal rated voltage</b>	12 VDC		
	AC mains	<b>Nominal rated voltage</b>	VAC	Frequency	Hz
<b>Common power source for transmitter and receiver</b>		yes		no	

\*The worst case variant of H-field strength measurements is a configuration without tag.



<b>Test specification: Section 15.209 / RSS-Gen, Section 6.5, 6.6 Field strength of emissions</b>			
Test procedure: ANSI C63.10, Section 6.4, 6.5			
Test mode: Compliance		Verdict: PASS	
Date(s): 21-Mar-23			
Temperature: 21 °C	Relative Humidity: 54 %	Air Pressure: 1012 hPa	Power: 12 VDC
Remarks:			

## 7 Transmitter tests according to 47CFR part 15 subpart C and RSS-210 requirements

### 7.1 Field strength of emissions

#### 7.1.1 General

This test was performed to measure field strength of fundamental and spurious emissions from the EUT. Specification test limits are given Table 7.1.1 and Table 7.1.2.

Table 7.1.1 Radiated fundamental emission limits

Fundamental frequency, kHz	Field strength at 3 m, dB(µV/m)	
	Peak	Average
125.65	125.64	105.64

Table 7.1.2 Radiated spurious emissions limits

Frequency, MHz	Field strength at 3 m, dB(µV/m)		
	Within restricted bands		
	Peak	Quasi Peak	Average
0.009 – 0.090	148.5 – 128.5	NA	128.5 – 108.5**
0.090 – 0.110	NA	108.5 – 106.8**	NA
0.110 – 0.490	126.8 – 113.8	NA	106.8 – 93.8**
0.490 – 1.705	NA	73.8 – 63.0**	NA
1.705 – 30.0*		69.5	
30 – 88		40.0	
88 – 216		43.5	
216 – 960		46.0	
960 - 1000		54.0	
1000 – 10 <sup>th</sup> harmonic	74.0	NA	54.0

\*- The limit for 3 m test distance was calculated using the inverse square distance extrapolation factor as follows:

$$\text{Lims}_2 = \text{Lims}_1 + 40 \log (S_1/S_2),$$

where S<sub>1</sub> and S<sub>2</sub> – standard defined and test distance respectively in meters.

\*\* - The limit decreases linearly with the logarithm of frequency.



<b>Test specification: Section 15.209 / RSS-Gen, Section 6.5, 6.6 Field strength of emissions</b>			
<b>Test procedure:</b> ANSI C63.10, Section 6.4, 6.5			
<b>Test mode:</b> Compliance		<b>Verdict: PASS</b>	
<b>Date(s):</b> 21-Mar-23			
<b>Temperature:</b> 21 °C	<b>Relative Humidity:</b> 54 %	<b>Air Pressure:</b> 1012 hPa	<b>Power:</b> 12 VDC
<b>Remarks:</b>			

**7.1.2 Test procedure for fundamental and spurious emission field strength measurements in 9 kHz to 30 MHz**

- 7.1.2.1 The EUT was set up as shown in Figure 7.1.1, energized and the performance check was conducted.
- 7.1.2.2 The specified frequency range was investigated with a loop antenna connected to spectrum analyzer/ EMI receiver. To find maximum radiation the turntable was rotated 360<sup>0</sup>, the measuring antenna was rotated around its vertical axis. The measuring antenna polarization was switched from vertical to horizontal.
- 7.1.2.3 The worst test results (the lowest margins) were recorded in Table 7.1.5 and shown in the associated plots.

**7.1.3 Test procedure for spurious emission field strength measurements above 30 MHz**

- 7.1.3.1 The EUT was set up as shown in Figure 7.1.2, energized and the performance check was conducted.
- 7.1.3.2 The specified frequency range was investigated with antenna connected to spectrum analyzer/ EMI receiver. To find maximum radiation the turntable was rotated 360<sup>0</sup>, the measuring antenna height was changed from 1 to 4 m, its polarization was switched from vertical to horizontal.
- 7.1.3.3 The worst test results (the lowest margins) were recorded in Table 7.1.6 and shown in the associated plots.





<b>Test specification:</b> Section 15.209 / RSS-Gen, Section 6.5, 6.6 Field strength of emissions			
<b>Test procedure:</b> ANSI C63.10, Section 6.4, 6.5			
<b>Test mode:</b> Compliance		<b>Verdict:</b> PASS	
<b>Date(s):</b> 21-Mar-23			
<b>Temperature:</b> 21 °C	<b>Relative Humidity:</b> 54 %	<b>Air Pressure:</b> 1012 hPa	<b>Power:</b> 12 VDC
<b>Remarks:</b>			

Figure 7.1.1 Setup for spurious emission field strength measurements below 30 MHz

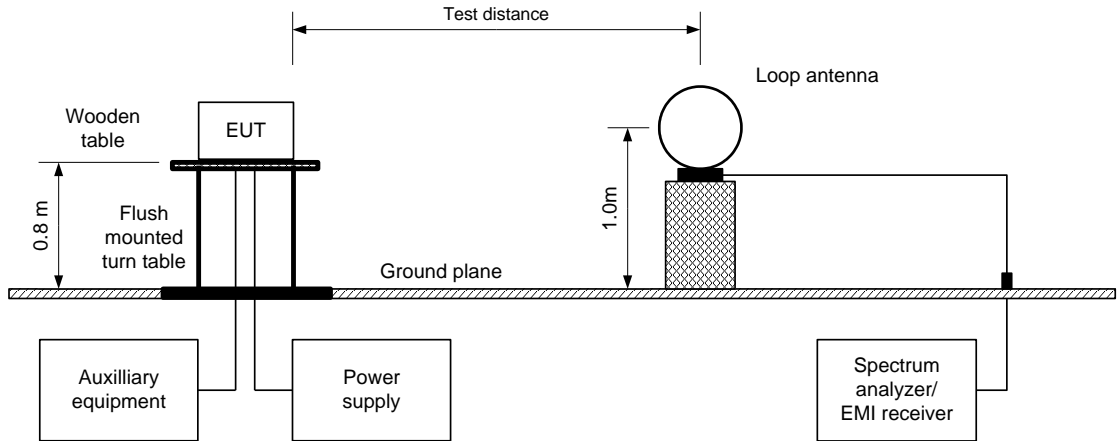
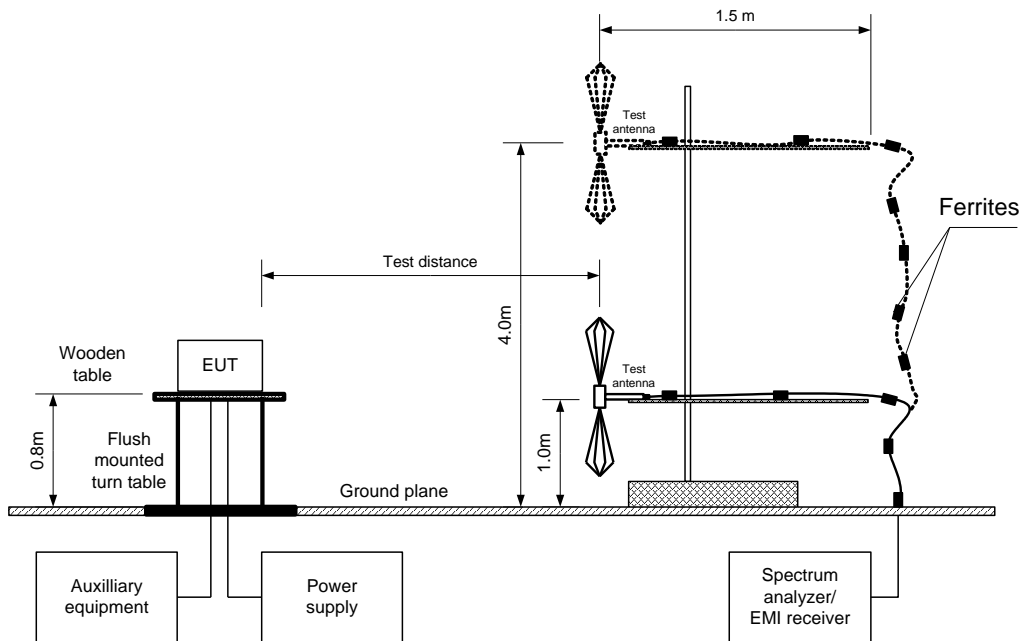

Figure 7.1.2 Setup for spurious emission field strength measurements above 30 MHz





<b>Test specification:</b> Section 15.209 / RSS-Gen, Section 6.5, 6.6 Field strength of emissions			
<b>Test procedure:</b> ANSI C63.10, Section 6.4, 6.5			
<b>Test mode:</b> Compliance		<b>Verdict:</b> PASS	
<b>Date(s):</b> 21-Mar-23			
<b>Temperature:</b> 21 °C	<b>Relative Humidity:</b> 54 %	<b>Air Pressure:</b> 1012 hPa	<b>Power:</b> 12 VDC
<b>Remarks:</b>			

**Table 7.1.3 Field strength of fundamental emission**

TEST DISTANCE: 3 m  
 TEST SITE: Same Anechoic chamber  
 EUT POSITION: Typical (Vertical)  
 TRANSMITTER OUTPUT POWER SETTINGS: Maximum  
 INVESTIGATED FREQUENCY RANGE: 0.009 – 30 MHz  
 DETECTOR USED: Peak  
 RESOLUTION BANDWIDTH: 1 kHz (9 kHz – 150 kHz)  
 9.0 kHz (150 kHz – 30 MHz)  
 VIDEO BANDWIDTH: ≥ Resolution bandwidth  
 TEST ANTENNA TYPE: Active loop (9 kHz – 30 MHz)

Frequency, kHz	Peak emission, dB(μV/m)	Quasi-peak			Antenna polarization	Antenna height, m	Turn-table position**, degrees	Verdict
		Measured emission, dB(μV/m)	Limit, dB(μV/m)	Margin, dB*				
125.63	81.732	81.732	105.64	-23.91	V	1.0	-13	Pass

\*- Margin = Measured emission - specification limit.  
 \*\*- EUT front panel refer to 0 degrees position of turntable.

**Reference numbers of test equipment used**

HL 0446	HL 3903	HL 5288	HL 5902	HL 7585			
---------	---------	---------	---------	---------	--	--	--

Full description is given in Appendix A.



<b>Test specification:</b> Section 15.209 / RSS-Gen, Section 6.5, 6.6 Field strength of emissions			
<b>Test procedure:</b> ANSI C63.10, Section 6.4, 6.5			
<b>Test mode:</b> Compliance		<b>Verdict:</b> PASS	
<b>Date(s):</b> 21-Mar-23			
<b>Temperature:</b> 21 °C	<b>Relative Humidity:</b> 54 %	<b>Air Pressure:</b> 1012 hPa	<b>Power:</b> 12 VDC
<b>Remarks:</b>			

Table 7.1.4 Field strength of spurious emissions

TEST DISTANCE: 3 m  
TEST SITE: Anechoic chamber  
EUT POSITION: Typical (Vertical)  
TRANSMITTER OUTPUT POWER SETTINGS: Maximum  
INVESTIGATED FREQUENCY RANGE: 0.009 – 1000 MHz  
DETECTOR USED: Peak  
RESOLUTION BANDWIDTH: 1 kHz (9 kHz – 150 kHz)  
9.0 kHz (150 kHz – 30 MHz)  
120 kHz (30 MHz – 1000 MHz)  
VIDEO BANDWIDTH: ≥ Resolution bandwidth  
TEST ANTENNA TYPE: Active loop (9 kHz – 30 MHz)  
Biconilog (30 MHz – 1000 MHz)

Frequency, kHz	Peak emission, dB(µV/m)	Average			Antenna polarization	Antenna height, m	Turn-table position**, degrees	Verdict
		Measured emission, dB(µV/m)	Limit, dB(µV/m)	Margin, dB*				
67.529	65.86	65.86	111.0	-45.14	V	1.0	-13	Pass
249.50	77.24	77.24	99.67	-22.44	V	1.0	6	Pass

\*- Margin = Measured emission - specification limit.

\*\* - EUT front panel refer to 0 degrees position of turntable.

Reference numbers of test equipment used

HL 0446	HL 3903	HL 5288	HL 5902	HL 7585			
---------	---------	---------	---------	---------	--	--	--

Full description is given in Appendix A.



<b>Test specification:</b> Section 15.209 / RSS-Gen, Section 6.5, 6.6 Field strength of emissions			
<b>Test procedure:</b> ANSI C63.10, Section 6.4, 6.5			
<b>Test mode:</b> Compliance		<b>Verdict:</b> PASS	
<b>Date(s):</b> 21-Mar-23			
<b>Temperature:</b> 21 °C	<b>Relative Humidity:</b> 54 %	<b>Air Pressure:</b> 1012 hPa	<b>Power:</b> 12 VDC
<b>Remarks:</b>			

Table 7.1.5 Restricted bands according to FCC 15, Section 205

MHz	MHz	MHz	MHz	MHz	GHz
0.09 - 0.11	8.37625 - 8.38675	73 - 74.6	399.9 - 410	2690 - 2900	10.6 - 12.7
0.495 - 0.505	8.41425 - 8.41475	74.8 - 75.2	608 - 614	3260 - 3267	13.25 - 13.4
2.1735 - 2.1905	12.290 - 12.293	108 - 121.94	960 - 1240	3332 - 3339	14.47 - 14.5
4.125 - 4.128	12.51975 - 12.52025	123 - 138	1300 - 1427	3345.8 - 3358	15.35 - 16.2
4.17725 - 4.17775	12.57675 - 12.57725	149.9 - 150.05	1435 - 1626.5	3600 - 4400	17.7 - 21.4
4.20725 - 4.20775	13.36 - 13.41	156.52475 - 156.52525	1645.5 - 1646.5	4500 - 5150	22.01 - 23.12
6.215 - 6.218	16.420 - 16.423	156.7 - 156.9	1660 - 1710	5350 - 5460	23.6 - 24
6.26775 - 6.26825	16.69475 - 16.69525	162.0125 - 167.17	1718.8 - 1722.2	7250 - 7750	31.2 - 31.8
6.31175 - 6.31225	16.80425 - 16.80475	167.72 - 173.2	2200 - 2300	8025 - 8500	36.43 - 36.5
8.291 - 8.294	25.5 - 25.67	240 - 285	2310 - 2390	9000 - 9200	Above 38.6
8.362 - 8.366	37.5 - 38.25	322 - 335.4	2483.5 - 2500	9300 - 9500	

Table 7.1.6 Restricted bands according to RSS-Gen, Table 3

MHz	MHz	MHz	MHz	MHz	GHz
0.09 - 0.11	8.291 - 8.294	16.80425 - 16.80475	399.9 - 410	3260 - 3267	10.6 - 12.7
2.1735 - 2.190	8.362 - 8.366	25.5 - 25.67	608 - 614	3332 - 3339	13.25 - 13.4
3.020 - 3.026	8.37625 - 8.38675	37.5 - 38.25	960 - 1427	3345.8 - 3358	14.47 - 14.5
4.125 - 4.128	8.41425 - 8.41475	73 - 74.6	1435 - 1626.5	3500 - 4400	15.35 - 16.2
4.17725 - 4.17775	12.290 - 12.293	74.8 - 75.2	1645.5 - 1646.5	4500 - 5150	17.7 - 21.4
4.20725 - 4.20775	12.51975 - 12.52025	108 - 138	1660 - 1710	5350 - 5460	22.01 - 23.12
5.677 - 5.683	12.57675 - 12.57725	156.52475 - 156.52525	1718.8 - 1722.2	7250 - 7750	23.6 - 24.0
6.215 - 6.218	13.36 - 13.41	156.7 - 156.9	2200 - 2300	8025 - 8500	31.2 - 31.8
6.26775 - 6.26825	16.42 - 16.423	240 - 285	2310 - 2390	9000 - 9200	36.43 - 36.5
6.31175 - 6.31225	16.69475 - 16.69525	322 - 335.4	2655 - 2900	9300 - 9500	Above 38.6



<b>Test specification:</b> Section 15.209 / RSS-Gen, Section 6.5, 6.6 Field strength of emissions			
<b>Test procedure:</b> ANSI C63.10, Section 6.4, 6.5			
<b>Test mode:</b> Compliance		<b>Verdict:</b> PASS	
<b>Date(s):</b> 21-Mar-23			
<b>Temperature:</b> 21 °C	<b>Relative Humidity:</b> 54 %	<b>Air Pressure:</b> 1012 hPa	<b>Power:</b> 12 VDC
<b>Remarks:</b>			

**Plot 7.1.1 Radiated emission measurements at the fundamental frequency**

TEST SITE: Semi anechoic chamber  
 TEST DISTANCE: 3 m  
 ANTENNA POLARIZATION: Vertical  
 EUT POSITION: Typical (Vertical)

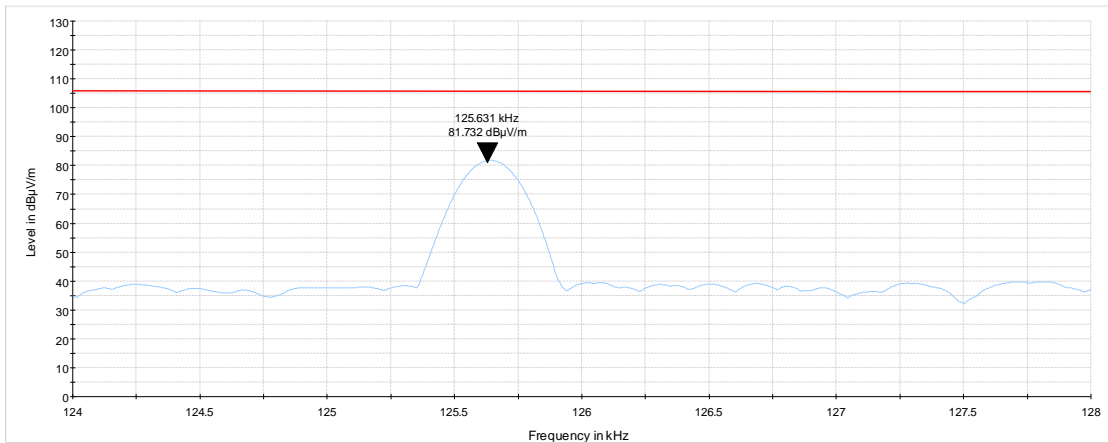

**Plot 7.1.2 Radiated emission measurements from 9 kHz to 30 MHz**

TEST SITE: Anechoic chamber  
 TEST DISTANCE: 3 m  
 ANTENNA POLARIZATION: Vertical  
 EUT POSITION: Typical (Vertical)

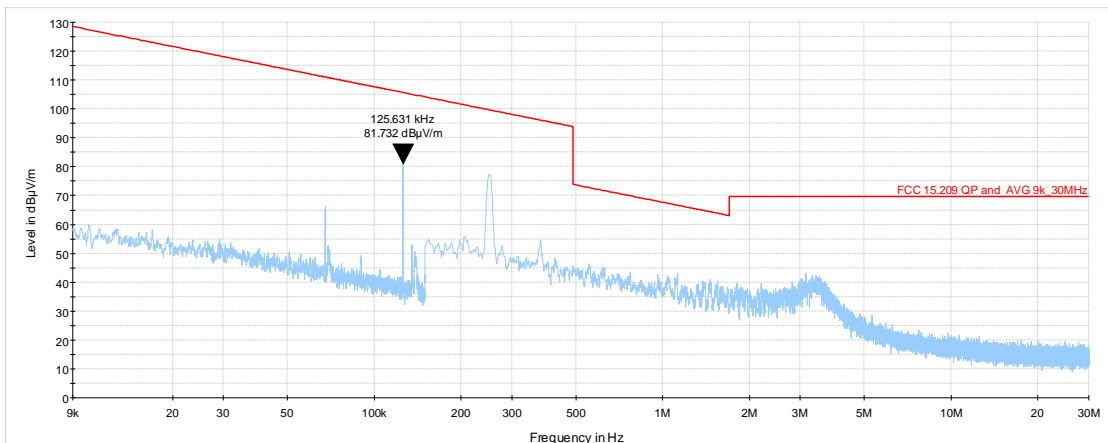



<b>Test specification: Section 15.209 / RSS-Gen, Section 6.5, 6.6 Field strength of emissions</b>			
<b>Test procedure:</b> ANSI C63.10, Section 6.4, 6.5			
<b>Test mode:</b> Compliance		<b>Verdict: PASS</b>	
<b>Date(s):</b> 21-Mar-23			
<b>Temperature:</b> 21 °C	<b>Relative Humidity:</b> 54 %	<b>Air Pressure:</b> 1012 hPa	<b>Power:</b> 12 VDC
<b>Remarks:</b>			

**Plot 7.1.3 Radiated emission measurements from 30 to 1000 MHz**

TEST SITE: Semi anechoic chamber  
TEST DISTANCE: 3 m  
ANTENNA POLARIZATION: Vertical  
EUT POSITION: Typical (Vertical)

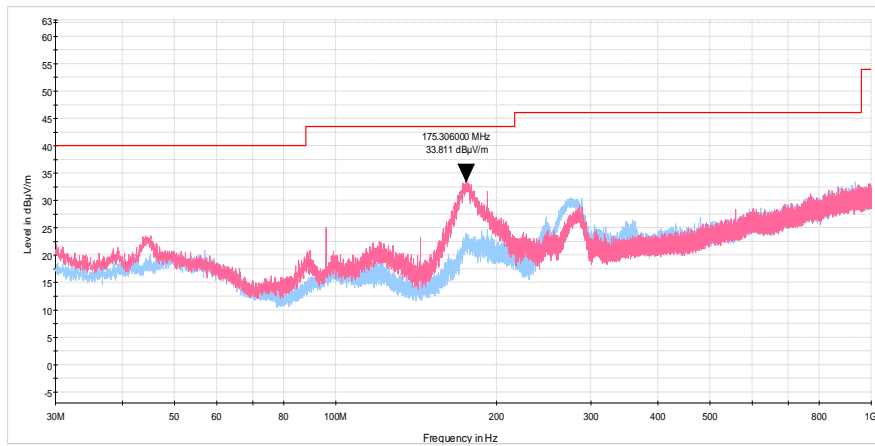



<b>Test specification: Section 15.215 / RSS-Gen, Section 6.7, Occupied bandwidth</b>			
<b>Test procedure:</b> ANSI C63.10, Section 6.9.2			
<b>Test mode:</b> Compliance		<b>Verdict: PASS</b>	
<b>Date(s):</b> 21-Mar-23			
<b>Temperature:</b> 21 °C	<b>Relative Humidity:</b> 54 %	<b>Air Pressure:</b> 1012 hPa	<b>Power:</b> 12 VDC
<b>Remarks:</b>			

## 7.2 Occupied bandwidth test

### 7.2.1 General

This test was performed to measure transmitter occupied bandwidth. Specification test limits are given in Table 7.2.1. The test results are provided in Table 7.2.2 and associated plots.

Table 7.2.1 Occupied bandwidth limits

Assigned frequency, kHz	Modulation envelope reference points, %	Maximum allowed bandwidth, of the carrier frequency
125.65	99	NA
Assigned frequency, kHz	Modulation envelope reference points*, dBc	Maximum allowed bandwidth, of the carrier frequency
125.65	20	NA

\*- Modulation envelope reference points provided in terms of attenuation below modulated carrier.

### 7.2.2 Test procedure

7.2.2.1 The EUT was set up as shown in Figure 7.2.1, energized and its proper operation was checked.

7.2.2.2 The EUT was set to transmit modulated carrier.

7.2.2.3 The transmitter occupied bandwidth was measured with spectrum analyzer as frequency delta between reference points on modulation envelope and provided in Table 7.2.2 and associated plot.

Figure 7.2.1 Occupied bandwidth test setup





<b>Test specification:</b> Section 15.215 / RSS-Gen, Section 6.7, Occupied bandwidth			
<b>Test procedure:</b> ANSI C63.10, Section 6.9.2			
<b>Test mode:</b> Compliance		<b>Verdict:</b> PASS	
<b>Date(s):</b> 21-Mar-23			
<b>Temperature:</b> 21 °C	<b>Relative Humidity:</b> 54 %	<b>Air Pressure:</b> 1012 hPa	<b>Power:</b> 12 VDC
<b>Remarks:</b>			

Table 7.2.2 Occupied bandwidth 20 dBc test results

DETECTOR USED: Peak hold  
RESOLUTION BANDWIDTH: 1 kHz  
VIDEO BANDWIDTH: 3 kHz  
MODULATION ENVELOPE REFERENCE POINTS: 20 dBc  
MODULATION: ASK

Carrier frequency, kHz	Occupied bandwidth, kHz*	Verdict
125.65	2.143	Pass

\* - Occupied bandwidth = Right cross point frequency - Left cross point frequency

DETECTOR USED: Peak hold  
RESOLUTION BANDWIDTH: 1 kHz  
VIDEO BANDWIDTH: 3 kHz  
MODULATION ENVELOPE REFERENCE POINTS: 99 %  
MODULATION: ASK

Carrier frequency, kHz	Occupied bandwidth, kHz*	Verdict
125.65	2.518	Pass

\* - Occupied bandwidth = Right cross point frequency - Left cross point frequency

Reference numbers of test equipment used

HL 3521	HL 5376	HL 5638	HL 6105					
---------	---------	---------	---------	--	--	--	--	--

Full description is given in Appendix A.





HERMON LABORATORIES

<b>Test specification:</b> Section 15.215 / RSS-Gen, Section 6.7, Occupied bandwidth			
<b>Test procedure:</b> ANSI C63.10, Section 6.9.2			
<b>Test mode:</b> Compliance		<b>Verdict:</b> PASS	
<b>Date(s):</b> 21-Mar-23			
<b>Temperature:</b> 21 °C	<b>Relative Humidity:</b> 54 %	<b>Air Pressure:</b> 1012 hPa	<b>Power:</b> 12 VDC
<b>Remarks:</b>			

Plot 7.2.1 20 dBc and 99% occupied bandwidth test result

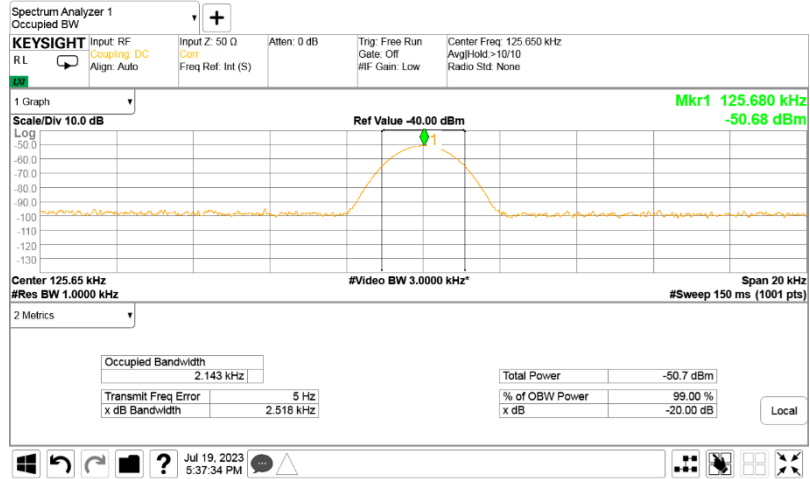



<b>Test specification:</b> FCC 47 CFR, Section 15.107 / ICES-003, Section 3.2.1, Class B, AC power lines conducted emissions			
<b>Test procedure:</b> ANSI C63.4, Section 7.3			
<b>Test mode:</b> Compliance		<b>Verdict:</b> PASS	
<b>Date(s):</b> 21-Mar-23			
<b>Temperature:</b> 21 °C	<b>Relative Humidity:</b> 54 %	<b>Air Pressure:</b> 1012 hPa	<b>Power:</b> 120 VAC, 50 Hz
<b>Remarks:</b>			

## 8 Unintentional emissions

### 8.1 Conducted emissions

#### 8.1.1 General

This test was performed to measure common mode conducted emissions at the mains power port. Specification test limits are given in Table 8.1.1.

Table 8.1.1 Limits for conducted emissions

Frequency, MHz	Class B limit, dB(μV)		Class A limit, dB(μV)	
	QP	AVRG	QP	AVRG
0.15 - 0.5	66 - 56*	56 - 46*	79	66
0.5 - 5.0	56	46	73	60
5.0 - 30	60	50	73	60

\* The limit decreases linearly with the logarithm of frequency.

#### 8.1.2 Test procedure

- 8.1.2.1 The EUT was set up as shown in Figure 8.1.1 and associated photographs, energized and the performance check was conducted.
- 8.1.2.2 The measurements were performed at power terminals with the LISN, connected to a spectrum analyzer in the frequency range referred to in Figure 8.1.1. Unused coaxial connector of the LISN was terminated with 50 Ohm. Quasi-peak and average detectors were used throughout the testing.
- 8.1.2.3 The position of the device cables was varied to determine maximum emission level.
- 8.1.2.4 The worst test results (the lowest margins) were recorded in Table 8.1.2 and shown in the associated plots.



<b>Test specification:</b> FCC 47 CFR, Section 15.107 / ICES-003, Section 3.2.1, Class B, AC power lines conducted emissions			
<b>Test procedure:</b> ANSI C63.4, Section 7.3			
<b>Test mode:</b> Compliance		<b>Verdict:</b> PASS	
<b>Date(s):</b> 21-Mar-23			
<b>Temperature:</b> 21 °C	<b>Relative Humidity:</b> 54 %	<b>Air Pressure:</b> 1012 hPa	<b>Power:</b> 120 VAC, 50 Hz
<b>Remarks:</b>			

Figure 8.1.1 Setup for conducted emission measurements, table-top equipment

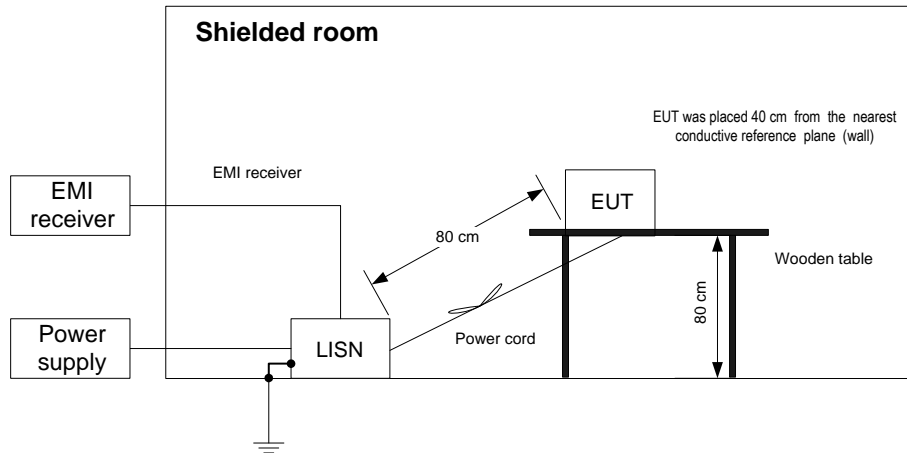



<b>Test specification:</b> FCC 47 CFR, Section 15.107 / ICES-003, Section 3.2.1, Class B, AC power lines conducted emissions			
<b>Test procedure:</b> ANSI C63.4, Section 7.3			
<b>Test mode:</b> Compliance		<b>Verdict:</b> PASS	
<b>Date(s):</b> 21-Mar-23			
<b>Temperature:</b> 21 °C	<b>Relative Humidity:</b> 54 %	<b>Air Pressure:</b> 1012 hPa	<b>Power:</b> 120 VAC, 50 Hz
<b>Remarks:</b>			

Table 8.1.2 Conducted emissions at AC mains input port test results

LINE: AC power input of access control module  
EUT SET UP: TABLE-TOP  
TEST SITE: SHIELDED ROOM  
DETECTORS USED: PEAK / QUASI-PEAK / AVERAGE  
FREQUENCY RANGE: 150 kHz - 30 MHz  
RESOLUTION BANDWIDTH: 9 kHz

Frequency, MHz	Peak emission, dB(µV)	Quasi-peak			Average			Line ID	Verdict
		Measured emission, dB(µV)	Limit, dB(µV)	Margin, dB*	Measured emission, dB(µV)	Limit, dB(µV)	Margin, dB*		
No emissions were found.								L1	Pass
No emissions were found.								L2	Pass

\*- Margin = Measured emission - specification limit.

Reference numbers of test equipment used

HL 0787	HL 1501	HL 3016	HL 5476	HL 5707			
---------	---------	---------	---------	---------	--	--	--

Full description is given in Appendix A.



HERMON LABORATORIES

<b>Test specification:</b> FCC 47 CFR, Section 15.107 / ICES-003, Section 3.2.1, Class B, AC power lines conducted emissions			
<b>Test procedure:</b> ANSI C63.4, Section 7.3			
<b>Test mode:</b> Compliance		<b>Verdict:</b> PASS	
<b>Date(s):</b> 21-Mar-23			
<b>Temperature:</b> 21 °C	<b>Relative Humidity:</b> 54 %	<b>Air Pressure:</b> 1012 hPa	<b>Power:</b> 120 VAC, 50 Hz
<b>Remarks:</b>			

**Plot 8.1.1 Conducted emission measurements**

LINE: L1  
 LIMIT: Class B  
 EUT OPERATING MODE: Receive  
 LIMIT: QUASI-PEAK, AVERAGE  
 DETECTOR: PEAK

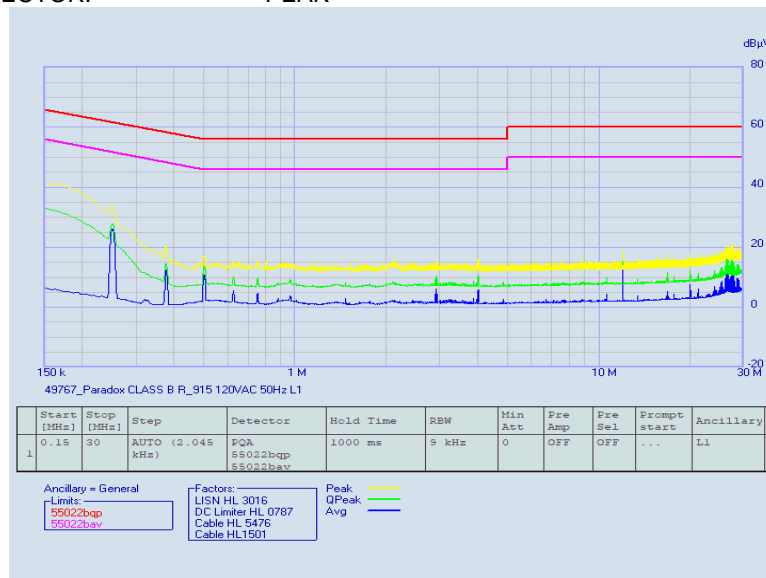



HERMON LABORATORIES

<b>Test specification:</b> FCC 47 CFR, Section 15.107 / ICES-003, Section 3.2.1, Class B, AC power lines conducted emissions			
<b>Test procedure:</b> ANSI C63.4, Section 7.3			
<b>Test mode:</b> Compliance		<b>Verdict:</b> PASS	
<b>Date(s):</b> 21-Mar-23			
<b>Temperature:</b> 21 °C	<b>Relative Humidity:</b> 54 %	<b>Air Pressure:</b> 1012 hPa	<b>Power:</b> 120 VAC, 50 Hz
<b>Remarks:</b>			

**Plot 8.1.2 Conducted emission measurements**

LINE: L2  
LIMIT: Class B  
EUT OPERATING MODE: Receive  
LIMIT: QUASI-PEAK, AVERAGE  
DETECTOR: PEAK

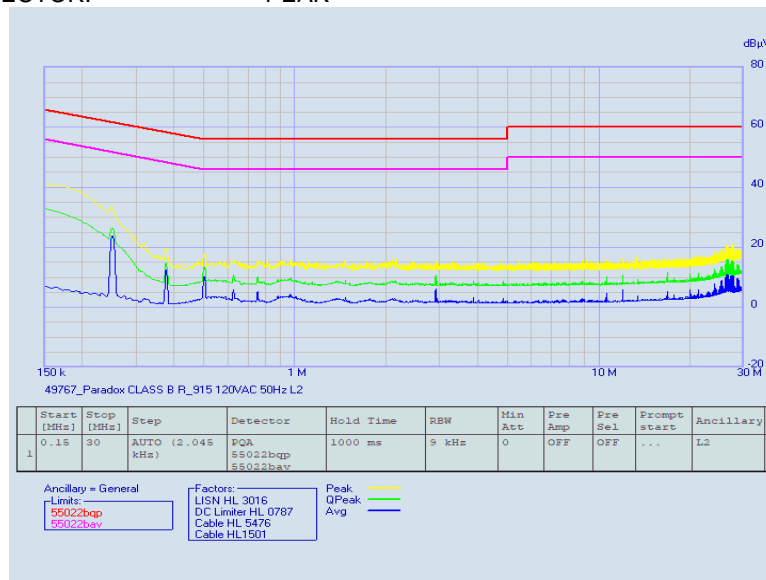



<b>Test specification:</b> FCC 47 CFR, Section 15.109 / ICES-003, Section 3.2.2, Class B, Radiated emissions			
<b>Test procedure:</b> ANSI C63.4, Section 8.3			
<b>Test mode:</b> Compliance		<b>Verdict:</b> PASS	
<b>Date(s):</b> 21-Mar-23			
<b>Temperature:</b> 21 °C	<b>Relative Humidity:</b> 54 %	<b>Air Pressure:</b> 1012 hPa	<b>Power:</b> 12 VDC
<b>Remarks:</b>			

## 8.2 Radiated emission measurements

### 8.2.1 General

This test was performed to measure radiated emissions from the EUT enclosure. The specification test limits are given in Table 8.2.1.

Table 8.2.1 Radiated emission test limits

Frequency, MHz	Class B limit, dB(μV/m)		Class A limit, dB(μV/m)	
	10 m distance	3 m distance	10 m distance	3 m distance
<b>FCC 47 CFR, Section 15.109</b>				
30 - 88	29.5*	40.0	39.0	49.5*
88 - 216	33.0*	43.5	43.5	54.0*
216 - 960	35.5*	46.0	46.4	56.9*
Above 960	43.5*	54.0	49.5	60.0*
<b>ICES-003, Section 3.2.2</b>				
30 - 88	30.0	40.0	40.0	50.0
88 - 216	33.1	43.5	43.5	54.0
216 - 230	35.6	46.0	46.4	56.9
230 - 960	37.0	47.0	47.0	57.0
960 - 1000	43.5	54.0	49.5	60.0
1000 - 40000	---	74 (Peak)   54 (AVR)	---	80 (Peak)   60 (AVR)

\* - The limit for a test distance other than specified was calculated using the inverse linear distance extrapolation factor as follows:  $Lim_{S_2} = Lim_{S_1} + 20 \log(S_1/S_2)$ , where  $S_1$  and  $S_2$  – the standard defined and the test distance respectively in meters.

### 8.2.2 Test procedure

**8.2.2.1 30 – 1000 MHz range.** The EUT was set up as shown in Figure 8.2.1 and the associated photographs, energized and the EUT performance was checked.

**8.2.2.2** The measurements were performed in the semi anechoic chamber at 3 m test distance. The specified frequency range was investigated with the antenna connected to the EMI receiver. To find the highest emission the turntable was rotated 360° and the measuring antenna height was swept from 1 to 4 m in both, vertical and horizontal polarizations. The EUT cables position was varied to maximize emission.

**8.2.2.3** The worst test results with respect to the limits were recorded in Table 8.2.2 and shown in the associated plot.



<b>Test specification:</b> FCC 47 CFR, Section 15.109 / ICES-003, Section 3.2.2, Class B, Radiated emissions			
<b>Test procedure:</b> ANSI C63.4, Section 8.3			
<b>Test mode:</b> Compliance		<b>Verdict:</b> PASS	
<b>Date(s):</b> 21-Mar-23			
<b>Temperature:</b> 21 °C	<b>Relative Humidity:</b> 54 %	<b>Air Pressure:</b> 1012 hPa	<b>Power:</b> 12 VDC
<b>Remarks:</b>			

Figure 8.2.1 Setup for radiated emission measurements in semi anechoic chamber below 1 GHz, table-top EUT

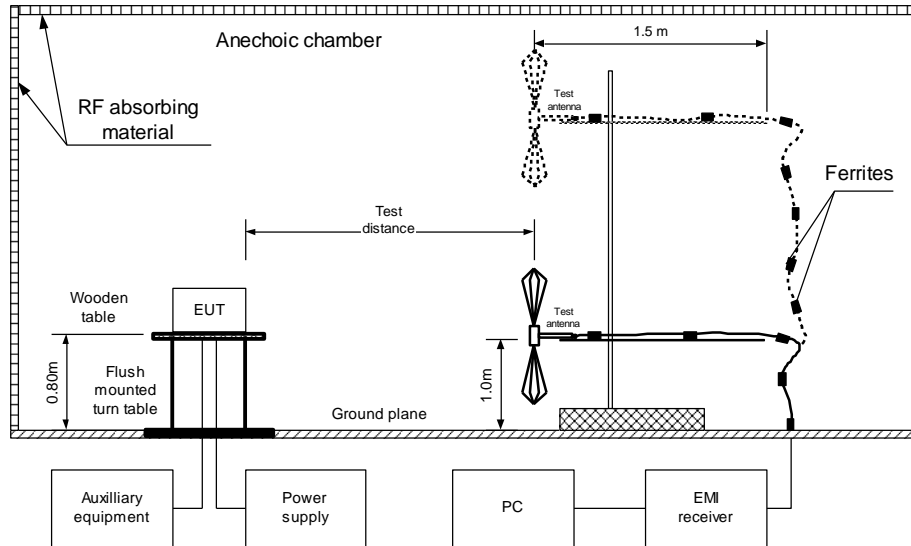

Table 8.2.2 Radiated emission test results

EUT SET UP: TABLE-TOP  
 TEST SITE: SEMI ANECHOIC CHAMBER  
 TEST DISTANCE: 3 m  
 DETECTORS USED: PEAK / QUASI-PEAK  
 FREQUENCY RANGE: 30 MHz – 1000 MHz  
 RESOLUTION BANDWIDTH: 120 kHz

Frequency, MHz	Peak emission, dB(μV/m)	Quasi-peak			Antenna polarization	Antenna height, m	Turn-table position**, degrees	Verdict
		Measured emission, dB(μV/m)	Limit, dB(μV/m)	Margin, dB*				
38.306	32.99	29.73	40.00	-10.27	Vertical	1.00	-180	Pass
95.992	32.73	29.90	40.00	-10.10	Vertical	1.00	-2	
149.272	31.17	27.00	40.00	-13.00	Vertical	1.00	-171	
191.990	34.36	31.93	40.00	-8.07	Vertical	1.00	141	
215.181	37.44	34.59	40.00	-5.41	Horizontal	1.41	-97	
256.101	35.31	32.66	47.00	-14.34	Vertical	1.00	114	

\*- Margin = Measured emission - specification limit.  
 \*\*- EUT front panel refers to 0 degrees position of turntable.

Reference numbers of test equipment used

HL 3903	HL 5085	HL 5288	HL 5902	HL 7585			
---------	---------	---------	---------	---------	--	--	--

Full description is given in Appendix A.





HERMON LABORATORIES

<b>Test specification:</b> FCC 47 CFR, Section 15.109 / ICES-003, Section 3.2.2, Class B, Radiated emissions			
<b>Test procedure:</b> ANSI C63.4, Section 8.3			
<b>Test mode:</b> Compliance		<b>Verdict:</b> PASS	
<b>Date(s):</b> 21-Mar-23			
<b>Temperature:</b> 21 °C	<b>Relative Humidity:</b> 54 %	<b>Air Pressure:</b> 1012 hPa	<b>Power:</b> 12 VDC
<b>Remarks:</b>			

Plot 8.2.1 Radiated emission measurements in 30 - 1000 MHz range, vertical & horizontal antenna polarization

TEST SITE:  
TEST DISTANCE:

Semi anechoic chamber  
3 m

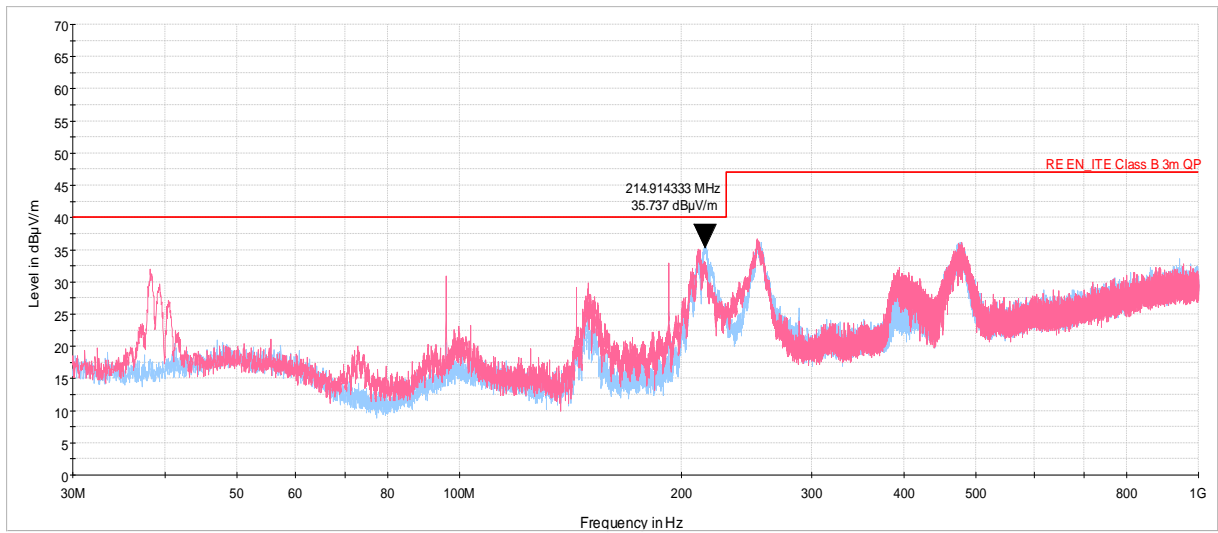

**9 APPENDIX A Test equipment and ancillaries used for tests**

HL No	Description	Manufacturer	Model	Ser. No.	Last Cal./ Check	Due Cal./ Check
0446	Antenna, Loop, Active, 10 (9) kHz - 30 MHz	EMCO	6502	2857	07-Mar-23	07-Apr-24
3521	Multimeter	Fluke	115	94771103	06-Jul-22	06-Jul-23
3903	Microwave Cable Assembly, 40.0 GHz, 1.5 m, SMA/SMA	Huber-Suhner	SUCOFL EX 102A	1226/2A	07-Apr-22	07-Apr-23
4933	Active Horn Antenna, 1 GHz to 18 GHz	COM-POWER CORPORATION	AHA-118	701046	19-Jan-23	19-Jan-24
5288	Trilog Antenna, 25 MHz - 8 GHz, 100W	Frankonia	ALX-8000E	00809	24-Mar-22	24-Mar-25
5376	EXA Signal Analyzer, 10 Hz - 32 GHz	Keysight Technologies	N9010B	MY57470404	27-Dec-22	27-Dec-23
5638	Cable, 50 Ohm, DC to 18 GHz, 1.8 m, SMA/SMA	Mini Circuits	CBL-6FT-SMSM+	NA	29-Nov-22	29-Nov-23
5902	RF cable, 18 GHz, 6.0m, N-type	Huber-Suhner	SF126EA/11N/11N/6000	NA	08-Dec-22	08-Dec-23
6105	Field Probe Set, 5 un	NA	NA	NA	05-Sep-22	05-Sep-23
7585	EMI Test Receiver, 1 Hz to 44 GHz	Rohde & Schwarz	ESW44	103130	19-May-22	19-Jun-23



### 10 APPENDIX B Test equipment correction factors

**HL 0446: Active Loop Antenna  
EMCO, model: 6502, s/n 2857**

Frequency,	Measured antenna factor, dBS/m	Measurement uncertainty, dB
10	-33.4	±1.0
20	-37.8	±1.0
50	-40.5	±1.0
75	-41.0	±1.0
100	-41.2	±1.0
150	-41.2	±1.0
250	-41.1	±1.0
500	-41.2	±1.0
750	-41.3	±1.0
1000	-41.3	±1.0

Frequency,	Measured antenna factor, dBS/m	Measurement uncertainty, dB
2000	-41.4	±1.0
3000	-41.4	±1.0
4000	-41.5	±1.0
5000	-41.5	±1.0
10000	-41.7	±1.0
15000	-42.1	±1.0
20000	-42.7	±1.0
25000	-44.2	±1.0
30000	-45.8	±1.0

The antenna factor shall be added to receiver reading in dB $\mu$ V to obtain field strength in dB $\mu$ A/m.

**HL 4933: Active Horn Antenna  
COM-POWER CORPORATION, model: AHA-118, s/n 701046**

Frequency, MHz	Measured antenna factor (with preamplifier), dB/m
1000	-16.1
1500	-15.1
2000	-10.9
2500	-11.9
3000	-11.1
3500	-10.6
4000	-8.6
4500	-8.3
5000	-5.9
5500	-5.7
6000	-3.3
6500	-4.0
7000	-2.2
7500	-1.7
8000	1.1
8500	-0.8
9000	-1.5
9500	-0.2

Frequency, MHz	Measured antenna factor (with preamplifier), dB/m
10000	1.8
10500	1.0
11000	0.3
11500	-0.5
12000	3.1
12500	1.4
13000	-0.3
13500	-0.4
14000	2.5
14500	2.2
15000	1.9
15500	0.5
16000	2.1
16500	1.2
17000	0.6
17500	3.1
18000	4.2

The antenna factor shall be added to receiver reading in dB $\mu$ V to obtain field strength in dB $\mu$ V/m.



**HL 5288: Trilog Antenna**  
**Frankonia, model: ALX-8000E, s/n: 00809**  
**30-1000 MHz**

Frequency, MHz	Antenna factor, dB/m
30	14.96
35	15.33
40	16.37
45	17.56
50	17.95
60	16.87
70	13.22
80	10.56
90	13.61
100	15.46
120	14.03
140	12.23

Frequency, MHz	Antenna factor, dB/m
160	12.67
180	13.34
200	15.40
250	16.42
300	17.28
400	19.98
500	21.11
600	22.90
700	24.13
800	25.25
900	26.35
1000	27.18

The antenna factor shall be added to receiver reading in dB $\mu$ V to obtain field strength in dB $\mu$ V/m.  
**above 1000 MHz**

Frequency, MHz	Antenna factor, dB/m
1000	26.9
1100	28.1
1200	28.4
1300	29.6
1400	29.1
1500	30.4
1600	30.7
1700	31.5
1800	32.3
1900	32.6
2000	32.5
2100	32.9
2200	33.5
2300	33.2
2400	33.7
2500	34.6
2600	34.7
2700	34.6
2800	35.0
2900	35.5
3000	36.2
3100	36.8
3200	36.8
3300	37.0
3400	37.5
3500	38.2

Frequency, MHz	Antenna factor, dB/m
3600	38.9
3700	39.4
3800	39.4
3900	39.6
4000	39.7
4100	39.8
4200	40.5
4300	40.9
4400	41.1
4500	41.4
4600	41.3
4700	41.6
4800	41.9
4900	42.3
5000	42.7
5100	43.0
5200	42.9
5300	43.5
5400	43.6
5500	44.3
5600	44.7
5700	45.0
5800	45.0
5900	45.3
6000	45.9

The antenna factor shall be added to receiver reading in dB $\mu$ V to obtain field strength in dB $\mu$ V/m.

**11 APPENDIX C Measurement uncertainties****Expanded uncertainty at 95% confidence in Hermon Labs EMC measurements**

<b>Test description</b>	<b>Expanded uncertainty</b>
Conducted emissions with LISN	9 kHz to 150 kHz: $\pm 3.9$ dB 150 kHz to 30 MHz: $\pm 3.8$ dB
Radiated emissions at 10 m measuring distance Horizontal polarization  Vertical polarization	Biconilog antenna: $\pm 5.0$ dB Biconical antenna: $\pm 5.0$ dB Log periodic antenna: $\pm 5.1$ dB Double ridged horn antenna: $\pm 5.3$ dB Biconilog antenna: $\pm 5.5$ dB Biconical antenna: $\pm 5.5$ dB Log periodic antenna: $\pm 5.6$ dB Double ridged horn antenna: $\pm 5.8$ dB
Radiated emissions at 3 m measuring distance Horizontal polarization  Vertical polarization	Biconilog antenna: $\pm 5.3$ dB Biconical antenna: $\pm 5.0$ dB Log periodic antenna: $\pm 5.3$ dB Double ridged horn antenna: $\pm 5.3$ dB Biconilog antenna: $\pm 6.0$ dB Biconical antenna: $\pm 5.7$ dB Log periodic antenna: $\pm 6.0$ dB Double ridged horn antenna: $\pm 6.0$ dB
Conducted emissions at RF antenna connector	9 kHz to 2.9 GHz: $\pm 2.6$ dB 2.9 GHz to 6.46 GHz: $\pm 3.5$ dB 6.46 GHz to 13.2 GHz: $\pm 4.3$ dB 13.2 GHz to 22.0 GHz: $\pm 5.0$ dB 22.0 GHz to 26.8 GHz: $\pm 5.5$ dB 26.8 GHz to 40.0 GHz: $\pm 4.8$ dB
Duty cycle, timing (Tx ON / OFF) and average factor measurements	$\pm 1.0$ %
Occupied bandwidth	$\pm 8.0$ %

Hermon Laboratories is accredited by A2LA for calibration according to present requirements of ISO/IEC 17025 and NCSL Z540-1. The accreditation is granted to perform calibration of parameters that are listed in the Scope of Hermon Laboratories Accreditation.

Hermon Laboratories calibrates its reference and transfer standards by calibration laboratories accredited to ISO/IEC 17025 by a mutually recognized Accreditation Body or by a recognized national metrology institute. All reference and transfer standards used in the calibration system are traceable to national or international standards.

In-house calibration of all test and measurement equipment is performed on a regular basis according to Hermon Laboratories calibration procedures, manufacturer calibration/verification procedures or procedures defined in the relevant standards. The Hermon Laboratories test and measurement equipment is calibrated within the tolerances specified by the manufacturers and/or by the relevant standards.



HERMON LABORATORIES

## 12 APPENDIX D Test laboratory description

Tests were performed at Hermon Laboratories Ltd., which is a fully independent, private, EMC, Radio, Safety, Environmental and Telecommunication testing facility.

Hermon Laboratories is recognized and accredited by the Federal Communications Commission (USA) for relevant parts of Code of Federal Regulations 47 (CFR 47), Test Firm Registration Number is 927748, Designation Number is IL1001; Recognized by Innovation, Science and Economic Development Canada for wireless and terminal testing (ISED), ISED #2186A, CAB identifier is IL1001; Certified by VCCI, Japan (the registration numbers for OATS are R-10808 for RE measurements below 1 GHz, G-20112 for RE measurements above 1 GHz, R-11082 for anechoic chamber for RE measurements below 1 GHz, G-10869 for RE measurements above 1 GHz, C-10845 for conducted emissions site and T-11606 for conducted emissions at telecommunication ports).

The laboratory is accredited by American Association for Laboratory Accreditation (USA) according to ISO/IEC 17025 for electromagnetic compatibility, product safety, telecommunications testing, environmental simulation and calibration (for exact scope please refer to Certificate No. 839.01, 839.03 and 839.04).

Address: P.O. Box 23, Binyamina 3055001, Israel.  
Telephone: +972 4628 8001  
Fax: +972 4628 8277  
e-mail: [mail@hermonlabs.com](mailto:mail@hermonlabs.com)  
website: [www.hermonlabs.com](http://www.hermonlabs.com)

Person for contact: Mr. Michael Nikishin, EMC&Radio group manager



### 13 APPENDIX E Specification references

47CFR part 15: 2021	Radio Frequency Devices.
RSS-210 Issue 10: 2019	Low Power Licence- Exempt Radiocommunication Devices
ANSI C63.10: 2013	American National Standard of Procedures for Compliance Testing of Unlicensed Wireless Devices
ANSI C63.4: 2014	American National Standard for Methods of Measurement of Radio-Noise Emissions from Low-Voltage Electrical and Electronic Equipment in the Range of 9 kHz to 40 GHz.
RSS-Gen Issue 5 with_amendment_1_2: 2021	General Requirements and Information for the Certification of Radiocommunication Equipment
ICES-003: 2020, Issue 7	Information Technology Equipment (Including Digital Apparatus) – Limits and methods of measurement



## 14 APPENDIX F Abbreviations and acronyms

AC	alternating current
A/m	ampere per meter
AM	amplitude modulation
AVRG	average (detector)
cm	centimeter
dB	decibel
dBm	decibel referred to one milliwatt
dB( $\mu$ V)	decibel referred to one microvolt
dB( $\mu$ V/m)	decibel referred to one microvolt per meter
dB( $\mu$ A)	decibel referred to one microampere
DC	direct current
EUT	equipment under test
F	frequency
GHz	gigahertz
GND	ground
H	height
HL	Hermon laboratories
Hz	hertz
k	kilo
kHz	kilohertz
LO	local oscillator
m	meter
MHz	megahertz
min	minute
mm	millimeter
ms	millisecond
$\mu$ s	microsecond
NA	not applicable
OATS	open area test site
$\Omega$	Ohm
PS	power supply
QP	quasi-peak
RE	radiated emission
RF	radio frequency
rms	root mean square
Rx	receive
s	second
T	temperature
Tx	transmit
V	volt

END OF DOCUMENT