



Hermon Laboratories Ltd.
Harakevet Industrial Zone, Binyamina 30500,
Israel
Tel. +972-4-6288001
Fax. +972-4-6288277
E-mail: mail@hermonlabs.com

TEST REPORT

ACCORDING TO: FCC 47CFR part 15 subpart C § 15.209 and subpart B;
RSS-210 issue 8 section 2.5.1, RSS-Gen issue 3,
ICES-003 Issue 5:2012

FOR:

Paradox Security Systems
Proximity reader and Keypad
Model: R915
FCC ID:KDYDGPR915
IC:2438A-DGPR915

This report is in conformity with ISO/IEC 17025. The "A2LA Accredited" symbol endorsement applies only to the tests and calibrations that are listed in the scope of Hermon Laboratories accreditation. The test results relate only to the items tested.
This test report shall not be reproduced in any form except in full with the written approval of Hermon Laboratories Ltd.

Table of contents

1	Applicant information	3
2	Equipment under test attributes	3
3	Manufacturer information	3
4	Test details	3
5	Tests summary	4
6	EUT description	5
6.1	General information	5
6.2	Ports and lines	5
6.3	Support and test equipment	5
6.4	Changes made in EUT	5
6.5	Test configuration	6
7	Transmitter tests according to 47CFR part 15 subpart C and RSS-210 requirements	7
7.1	Field strength of emissions	7
7.2	Antenna requirements	15
7.3	Occupied bandwidth test	16
7.4	Conducted emissions	19
8	Unintentional emissions	22
8.1	Conducted emissions	22
8.2	Radiated emission measurements	26
9	APPENDIX A Test equipment and ancillaries used for tests	31
10	APPENDIX B Measurement uncertainties	32
11	APPENDIX C Test laboratory description	33
12	APPENDIX D Specification references	33
13	APPENDIX E Test equipment correction factors	34
14	APPENDIX F Abbreviations and acronyms	40

1 Applicant information

Client name: Paradox Security Systems
Address: 780 Industriel BLVD, St-Eustache, QC, J7R 5V3, Canada
Telephone: 450-491-7444
Fax: 450-491-1095
E-mail: nimrodh@paradox.com
Contact name: Mr. Nimrod Herman

2 Equipment under test attributes

Product name: Proximity reader and Keypad
Product type: Transceiver
Model(s): R915
Serial number: 12B304EB
Hardware version: 671-2122-020
Software release: V1.01
Receipt date: 28-Jul-14

3 Manufacturer information

Manufacturer name: Paradox Security Systems
Address: 780 Industriel BLVD, St-Eustache, QC, J7R 5V3, Canada
Telephone: 450-491-7444
Fax: 450-491-1095
E-Mail: nimrodh@paradox.com
Contact name: Mr. Nimrod Herman

4 Test details



Project ID: 25767
Location: Hermon Laboratories Ltd. Harakevet Industrial Zone, Binyamina 30500, Israel
Test started: 28-Jul-14
Test completed: 30-Jul-14
Test specification(s): FCC 47CFR part 15, subpart C, §15.209;
RSS-210 issue 8 section 2.5.1, RSS-Gen issue 3 Table 6

5 Tests summary

Test	Status
Transmitter characteristics	
FCC section 15.209, RSS-Gen section 7.2.5, Field strength of emissions	Pass
FCC section 15.207(a) / RSS-Gen, Section 7.2.4, Conducted emission	Pass
FCC section 15.203, RSS-Gen section 7.1.2, Antenna requirement	Pass
RSS-Gen, Section 4.6.1, Occupied bandwidth	Tested
Unintentional emissions	
Section 15.107, Conducted emission at AC power port	Pass
Section 15.109, Radiated emission	Pass

Testing was completed against all relevant requirements of the test standard. The results obtained indicate that the product under test complies in full with the requirements tested.
The test results relate only to the items tested. Pass/ fail decision was based on nominal values.

This test report supersedes the previously issued test report identified by Doc ID:PARRAD_FCC.25767.

	Name and Title	Date	Signature
Tested by:	Mr. V. Einem, test engineer	July 30, 2014	
Reviewed by:	Mrs. M. Cherniavsky, certification engineer	August 6, 2014	
Approved by:	Mr. M. Nikishin, EMC and Radio group manager	August 6, 2014	



6 EUT description

6.1 General information

The EUT is a proximity reader and keypad operating at 125 kHz. The device utilizes the internal printed antenna, the gain is not defined.

6.2 Ports and lines

Port type	Port description	Connected from	Connected to	Qty.	Cable type	Cable length, m
Power	16 V AC	Mains via transformer	Control panel		Unshielded	1.5
Signal	Signal +DC power	Control panel	EUT	1	Unshielded	10

6.3 Support and test equipment

Description	Manufacturer	Model number	Serial number
Control Panel	Paradox	TM50	AT00018032

6.4 Changes made in EUT

No changes were performed in the EUT during the testing.

6.5 Test configuration

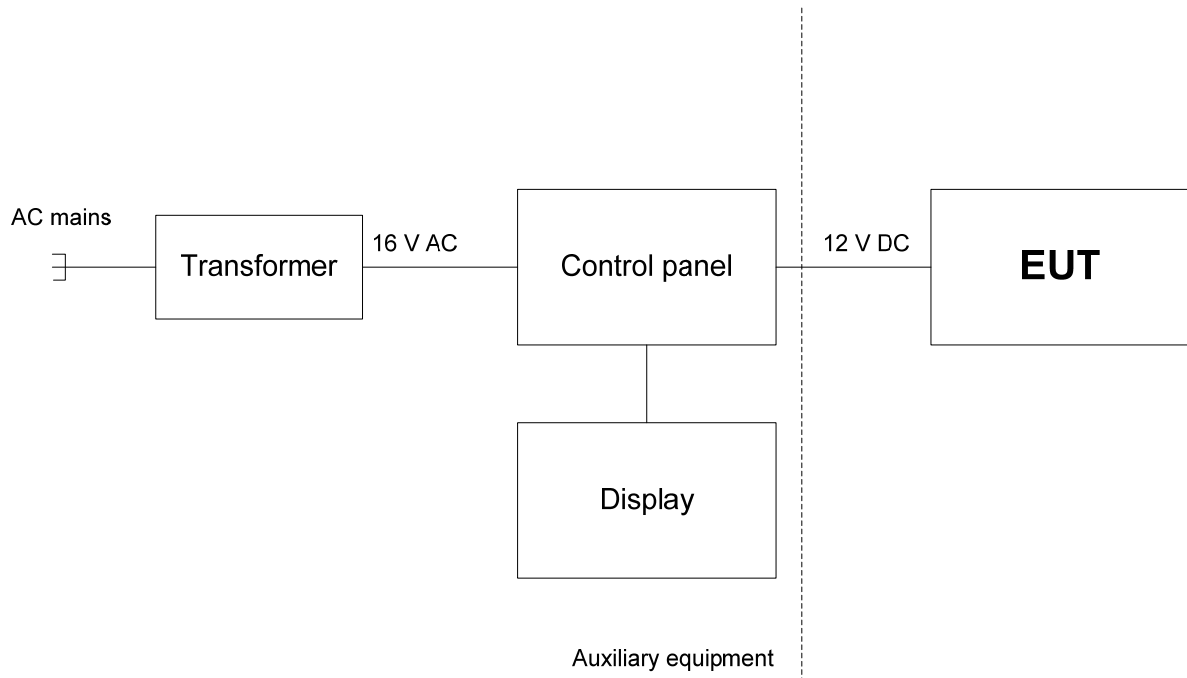



Test specification:	Section 15.209 / RSS-210, Tables 2, 3, Field strength of emissions		
Test procedure:	ANSI C63.4, Section 13.1.4		
Test mode:	Compliance	Verdict:	PASS
Date(s):	28-Jul-14		
Temperature: 26 °C	Air Pressure: 1010 hPa	Relative Humidity: 42 %	Power Supply: 12 VDC
Remarks:			

7 Transmitter tests according to 47CFR part 15 subpart C and RSS-210 requirements

7.1 Field strength of emissions

7.1.1 General

This test was performed to measure field strength of fundamental and spurious emissions from the EUT. Specification test limits are given Table 7.1.1 and Table 7.1.2.

Table 7.1.1 Radiated fundamental emission limits

Fundamental frequency, kHz	Field strength at 3 m, dB(μV/m)	
	Peak	Average
125	125.69	105.69

Table 7.1.2 Radiated spurious emissions limits

Frequency, MHz	Field strength at 3 m, dB(μV/m)		
	Within restricted bands		
	Peak	Quasi Peak	Average
0.009 – 0.090	148.5 – 128.5	NA	128.5 – 108.5**
0.090 – 0.110	NA	108.5 – 106.8**	NA
0.110 – 0.490	126.8 – 113.8	NA	106.8 – 93.8**
0.490 – 1.705	NA	73.8 – 63.0**	NA
1.705 – 30.0*		69.5	
30 – 88		40.0	
88 – 216		43.5	
216 – 960		46.0	
960 - 1000		54.0	
1000 – 10 th harmonic	74.0	NA	54.0

*- The limit for 3 m test distance was calculated using the inverse square distance extrapolation factor as follows:

$$\text{Lim}_{S_2} = \text{Lim}_{S_1} + 40 \log (S_1/S_2),$$

where S₁ and S₂ – standard defined and test distance respectively in meters.

** - The limit decreases linearly with the logarithm of frequency.

7.1.2 Test procedure for fundamental and spurious emission field strength measurements in 9 kHz to 30 MHz

7.1.2.1 The EUT was set up as shown in Figure 7.1.1, energized and the performance check was conducted.

7.1.2.2 The specified frequency range was investigated with a loop antenna connected to spectrum analyzer/ EMI receiver. To find maximum radiation the turntable was rotated 360°, the measuring antenna was rotated around its vertical axis. The measuring antenna polarization was switched from vertical to horizontal.

7.1.2.3 The worst test results (the lowest margins) were recorded in Table 7.1.3 and shown in the associated plots.

7.1.3 Test procedure for spurious emission field strength measurements above 30 MHz

7.1.3.1 The EUT was set up as shown in Figure 7.1.2, energized and the performance check was conducted.

7.1.3.2 The specified frequency range was investigated with antenna connected to spectrum analyzer/ EMI receiver. To find maximum radiation the turntable was rotated 360°, the measuring antenna height was changed from 1 to 4 m, its polarization was switched from vertical to horizontal.

7.1.3.3 The worst test results (the lowest margins) were recorded in Table 7.1.4 and shown in the associated plots.



Test specification:	Section 15.209 / RSS-210, Tables 2, 3, Field strength of emissions		
Test procedure:	ANSI C63.4, Section 13.1.4		
Test mode:	Compliance	Verdict:	PASS
Date(s):	28-Jul-14		
Temperature: 26 °C	Air Pressure: 1010 hPa	Relative Humidity: 42 %	Power Supply: 12 VDC
Remarks:			

Figure 7.1.1 Setup for spurious emission field strength measurements below 30 MHz

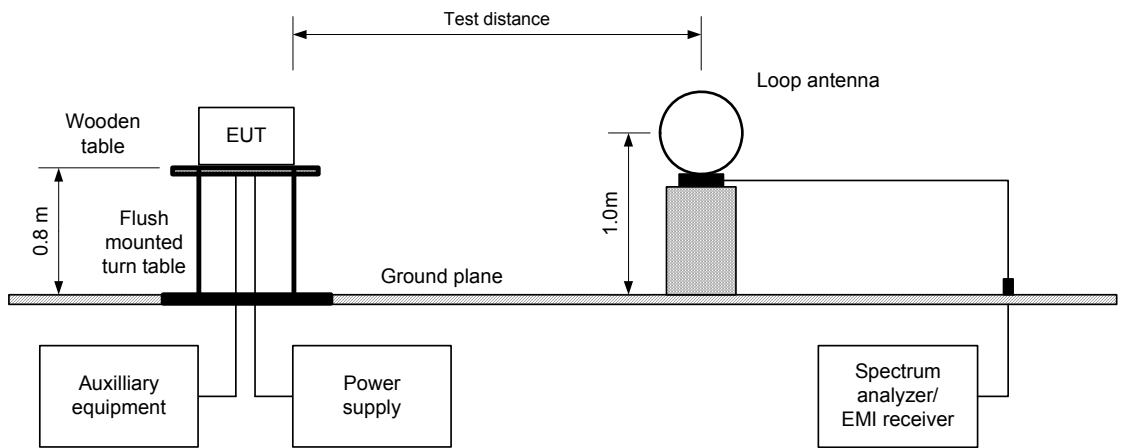
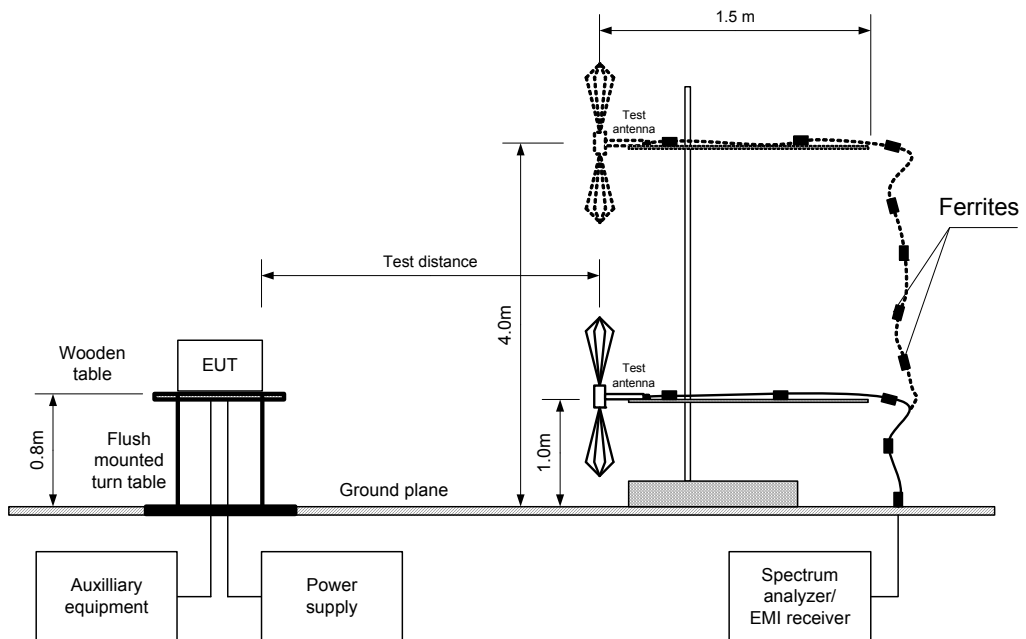

Figure 7.1.2 Setup for spurious emission field strength measurements above 30 MHz





Test specification:		Section 15.209 / RSS-210, Tables 2, 3, Field strength of emissions			
Test procedure:		ANSI C63.4, Section 13.1.4			
Test mode:		Compliance		Verdict: PASS	
Date(s):		28-Jul-14			
Temperature: 26 °C		Air Pressure: 1010 hPa		Relative Humidity: 42 %	
Remarks:		Power Supply: 12 VDC			

Table 7.1.3 Field strength of fundamental emission

TEST DISTANCE: 3 m
 TEST SITE: Semi Anechoic chamber
 EUT POSITION: Typical (Vertical)
 MODULATING SIGNAL: RFID
 INVESTIGATED FREQUENCY RANGE: 0.009 – 1000 MHz
 DETECTOR USED: Peak
 RESOLUTION BANDWIDTH: 1 kHz (9 kHz – 150 kHz)
 9.0 kHz (150 kHz – 30 MHz)
 120 kHz (30 MHz – 1000 MHz)
 VIDEO BANDWIDTH: ≥ Resolution bandwidth
 TEST ANTENNA TYPE: Active loop (9 kHz – 30 MHz)

F, kHz	Antenna		Azimuth, degrees*	Peak field strength			Average field strength			Verdict
	Pol.	Height, m		Measured, dB(μV/m)	Limit, dB(μV/m)	Margin, dB**	Measured, dB(μV/m)	Limit, dB(μV/m)	Margin, dB**	
127.0	Vertical	1.0	0	73.2	125.69	-52.49	72.4	105.69	-33.29	Pass

*- EUT front panel refers to 0 degrees position of turntable.
 **- Margin (dB) = measured result - specification limit.

Reference numbers of test equipment used

HL 0446	HL 0521	HL 4353	HL 4722				
---------	---------	---------	---------	--	--	--	--

Full description is given in Appendix A.



Test specification:		Section 15.209 / RSS-210, Tables 2, 3, Field strength of emissions	
Test procedure:		ANSI C63.4, Section 13.1.4	
Test mode:		Compliance	
Date(s):		28-Jul-14	
Temperature: 26 °C		Air Pressure: 1010 hPa	
		Relative Humidity: 42 %	
		Power Supply: 12 VDC	
Remarks:			

Table 7.1.4 Field strength of spurious emissions

TEST DISTANCE: 3 m
 TEST SITE: Semi Anechoic chamber
 EUT POSITION: Typical (Vertical)
 MODULATING SIGNAL: RFID
 INVESTIGATED FREQUENCY RANGE: 0.009 – 1000 MHz
 DETECTOR USED: Peak
 RESOLUTION BANDWIDTH: 1 kHz (9 kHz – 150 kHz)
 9.0 kHz (150 kHz – 30 MHz)
 120 kHz (30 MHz – 1000 MHz)
 VIDEO BANDWIDTH: ≥ Resolution bandwidth
 TEST ANTENNA TYPE: Active loop (9 kHz – 30 MHz)
 Biconilog (30 MHz – 1000 MHz)

Frequency, MHz	Peak emission, dB(µV/m)	Quasi-peak			Antenna polarization	Antenna height, m	Turn-table position**, degrees	Verdict
		Measured emission, dB(µV/m)	Limit, dB(µV/m)	Margin, dB*				
5.1677	53.53	50.13	69.5	-19.37	Vertical	1.0	0	Pass
33.507	35.38	31.42	40.0	-8.58	Vertical	1.0	34	
38.602	40.22	37.69	40.0	-2.31	Vertical	1.0	0	
44.033	33.31	29.58	40.0	-10.42	Vertical	1.0	345	
47.612	32.26	29.63	40.0	-10.37	Vertical	1.0	123	

*- Margin = Measured emission - specification limit.
 **- EUT front panel refer to 0 degrees position of turntable.

Reference numbers of test equipment used

HL 0446	HL 0521	HL 0604	HL 4353	HL 4722			
---------	---------	---------	---------	---------	--	--	--

Full description is given in Appendix A.



Test specification:		Section 15.209 / RSS-210, Tables 2, 3, Field strength of emissions			
Test procedure:		ANSI C63.4, Section 13.1.4			
Test mode:		Compliance		Verdict: PASS	
Date(s):		28-Jul-14			
Temperature: 26 °C		Air Pressure: 1010 hPa		Relative Humidity: 42 %	
Remarks:		Power Supply: 12 VDC			

Table 7.1.5 Restricted bands according to FCC 15, Section 205

MHz	MHz	MHz	MHz	MHz	GHz
0.09 - 0.11	8.37625 - 8.38675	73 - 74.6	399.9 - 410	2690 - 2900	10.6 - 12.7
0.495 - 0.505	8.41425 - 8.41475	74.8 - 75.2	608 - 614	3260 - 3267	13.25 - 13.4
2.1735 - 2.1905	12.290 - 12.293	108 - 121.94	960 - 1240	3332 - 3339	14.47 - 14.5
4.125 - 4.128	12.51975 - 12.52025	123 - 138	1300 - 1427	3345.8 - 3358	15.35 - 16.2
4.17725 - 4.17775	12.57675 - 12.57725	149.9 - 150.05	1435 - 1626.5	3600 - 4400	17.7 - 21.4
4.20725 - 4.20775	13.36 - 13.41	156.52475 - 156.52525	1645.5 - 1646.5	4500 - 5150	22.01 - 23.12
6.215 - 6.218	16.420 - 16.423	156.7 - 156.9	1660 - 1710	5350 - 5460	23.6 - 24
6.26775 - 6.26825	16.69475 - 16.69525	162.0125 - 167.17	1718.8 - 1722.2	7250 - 7750	31.2 - 31.8
6.31175 - 6.31225	16.80425 - 16.80475	167.72 - 173.2	2200 - 2300	8025 - 8500	36.43 - 36.5
8.291 - 8.294	25.5 - 25.67	240 - 285	2310 - 2390	9000 - 9200	Above 38.6
8.362 - 8.366	37.5 - 38.25	322 - 335.4	2483.5 - 2500	9300 - 9500	

Table 7.1.6 Restricted bands according to RSS-Gen, Table 3

MHz	MHz	MHz	MHz	MHz	GHz
0.09 - 0.11	8.291 - 8.294	16.80425 - 16.80475	399.9 - 410	3260 - 3267	10.6 - 12.7
2.1735 - 2.190	8.362 - 8.366	25.5 - 25.67	608 - 614	3332 - 3339	13.25 - 13.4
3.020 - 3.026	8.37625 - 8.38675	37.5 - 38.25	960 - 1427	3345.8 - 3358	14.47 - 14.5
4.125 - 4.128	8.41425 - 8.41475	73 - 74.6	1435 - 1626.5	3500 - 4400	15.35 - 16.2
4.17725 - 4.17775	12.290 - 12.293	74.8 - 75.2	1645.5 - 1646.5	4500 - 5150	17.7 - 21.4
4.20725 - 4.20775	12.51975 - 12.52025	108 - 138	1660 - 1710	5350 - 5460	22.01 - 23.12
5.677 - 5.683	12.57675 - 12.57725	156.52475 - 156.52525	1718.8 - 1722.2	7250 - 7750	23.6 - 24.0
6.215 - 6.218	13.36 - 13.41	156.7 - 156.9	2200 - 2300	8025 - 8500	31.2 - 31.8
6.26775 - 6.26825	16.42 - 16.423	240 - 285	2310 - 2390	9000 - 9200	36.43 - 36.5
6.31175 - 6.31225	16.69475 - 16.69525	322 - 335.4	2655 - 2900	9300 - 9500	Above 38.6



HERMON LABORATORIES

Test specification:		Section 15.209 / RSS-210, Tables 2, 3, Field strength of emissions	
Test procedure:		ANSI C63.4, Section 13.1.4	
Test mode:		Compliance	
Date(s):		28-Jul-14	
Temperature: 26 °C		Air Pressure: 1010 hPa	
Remarks:		Verdict: PASS	
		Relative Humidity: 42 %	
		Power Supply: 12 VDC	

Plot 7.1.1 Radiated emission measurements at the fundamental frequency

TEST SITE: Semi anechoic chamber
 TEST DISTANCE: 3 m
 ANTENNA POLARIZATION: Vertical and Horizontal
 EUT POSITION: Typical (Vertical)

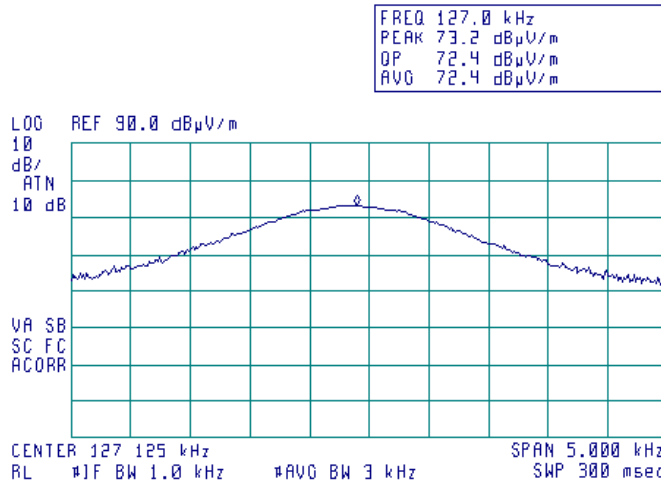

Plot 7.1.2 Radiated emission measurements from 9 to 150 kHz

TEST SITE: Anechoic chamber
 TEST DISTANCE: 3 m
 ANTENNA POLARIZATION: Vertical
 EUT POSITION: Typical (Vertical)

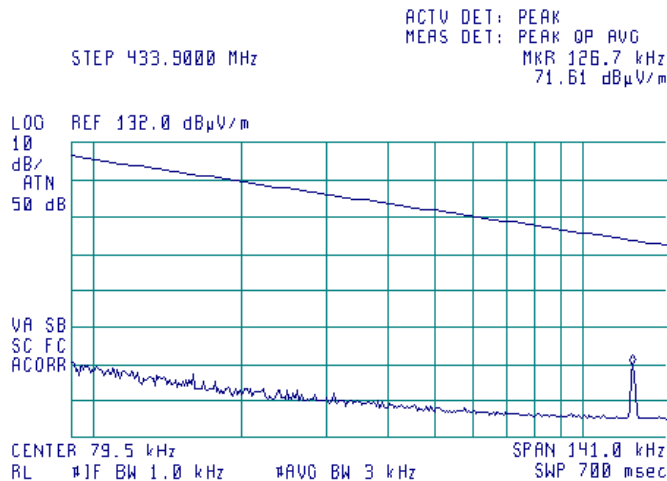



HERMON LABORATORIES

Test specification:		Section 15.209 / RSS-210, Tables 2, 3, Field strength of emissions	
Test procedure:		ANSI C63.4, Section 13.1.4	
Test mode:		Compliance	
Date(s):		28-Jul-14	
Temperature: 26 °C		Air Pressure: 1010 hPa	
		Relative Humidity: 42 %	
		Power Supply: 12 VDC	
Remarks:			
		Verdict: PASS	

Plot 7.1.3 Radiated emission measurements from 0.15 to 30 MHz

TEST SITE: Anechoic chamber
 TEST DISTANCE: 3 m
 ANTENNA POLARIZATION: Vertical
 EUT POSITION: Typical (Vertical)

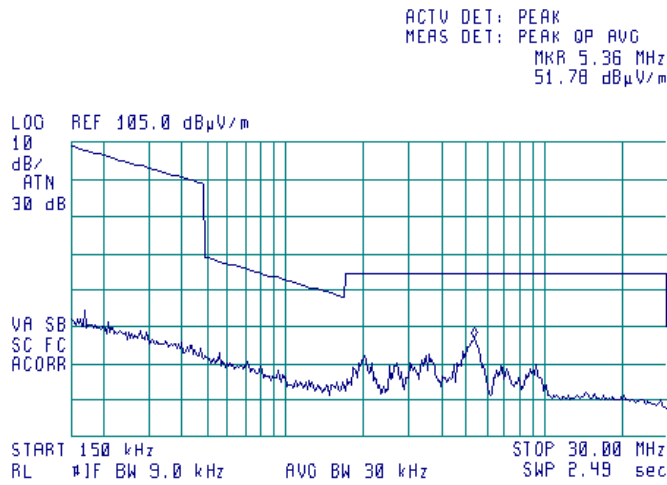

Plot 7.1.4 Radiated emission measurements from 30 to 1000 MHz

TEST SITE: Semi anechoic chamber
 TEST DISTANCE: 3 m
 ANTENNA POLARIZATION: Vertical
 EUT POSITION: Typical (Vertical)

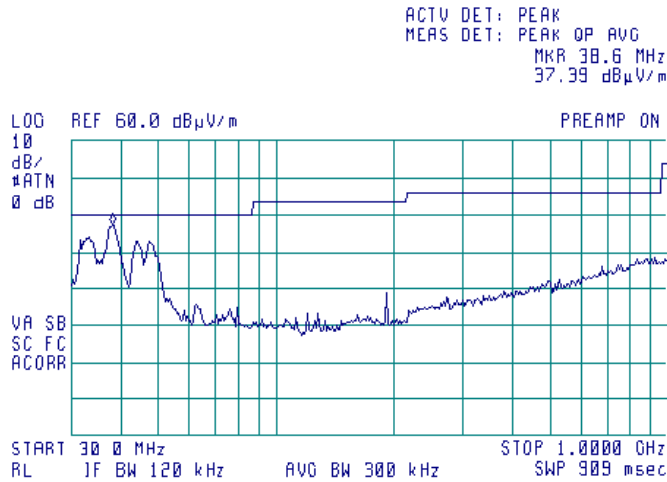



HERMON LABORATORIES

Test specification:	Section 15.209 / RSS-210, Tables 2, 3, Field strength of emissions		
Test procedure:	ANSI C63.4, Section 13.1.4		
Test mode:	Compliance	Verdict:	PASS
Date(s):	28-Jul-14		
Temperature: 26 °C	Air Pressure: 1010 hPa	Relative Humidity: 42 %	Power Supply: 12 VDC
Remarks:			

Plot 7.1.5 Radiated emission measurements from 30 to 1000 MHz

TEST SITE: Semi anechoic chamber
 TEST DISTANCE: 3 m
 ANTENNA POLARIZATION: Horizontal
 EUT POSITION: Typical (Vertical)

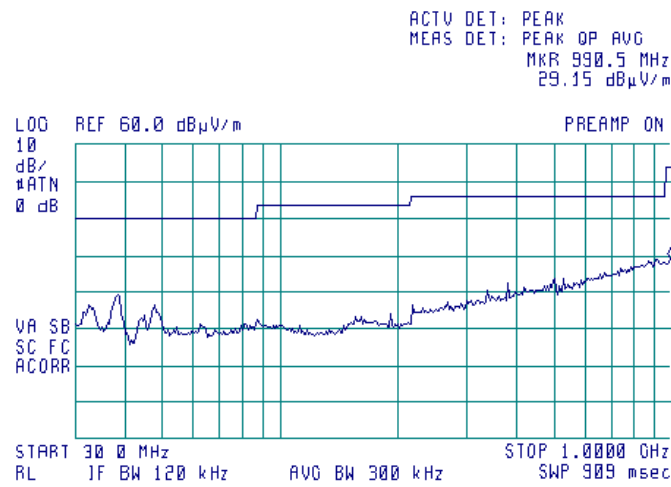

Plot 7.1.6 Transmission pulse duration

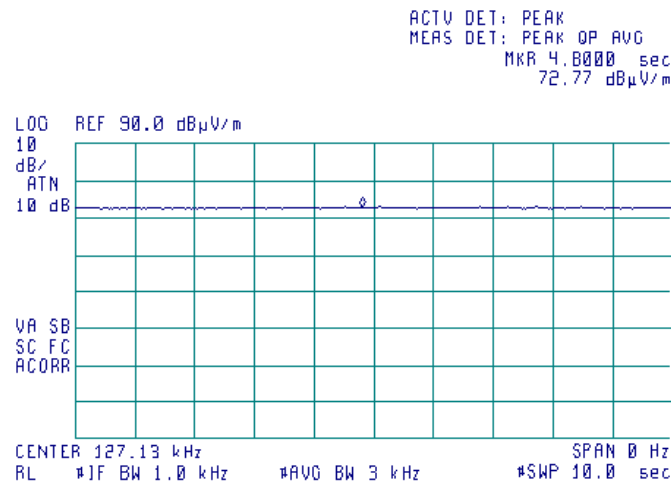



Test specification:	FCC Part 15, Section 203 / RSS-Gen, Section 7.1.2, Antenna requirements		
Test procedure:	Visual inspection/supplier declaration		
Test mode:	Compliance	Verdict:	PASS
Date(s):	29-Jul-14		
Temperature: 25 °C	Air Pressure: 1010 hPa	Relative Humidity: 42 %	Power Supply: 12 VDC
Remarks:			

7.2 Antenna requirements

The EUT was verified for compliance with antenna requirements. A transmitter shall be designed to ensure that no antenna other than that furnished by the responsible party will be used with the device. It may be either permanently attached or employs a unique antenna connector for every antenna proposed for use with the EUT. This requirement does not apply to professionally installed transmitters.

The rationale for compliance with the above requirements was either visual inspection results or supplier declaration. The summary of results is provided in Table 7.2.1.

Table 7.2.1 Antenna requirements

Requirement	Rationale	Verdict
The transmitter antenna is permanently attached	Visual inspection	Comply
The transmitter employs a unique antenna connector	NA	
The transmitter requires professional installation	NA	

Photograph 7.2.1 Antenna assembly

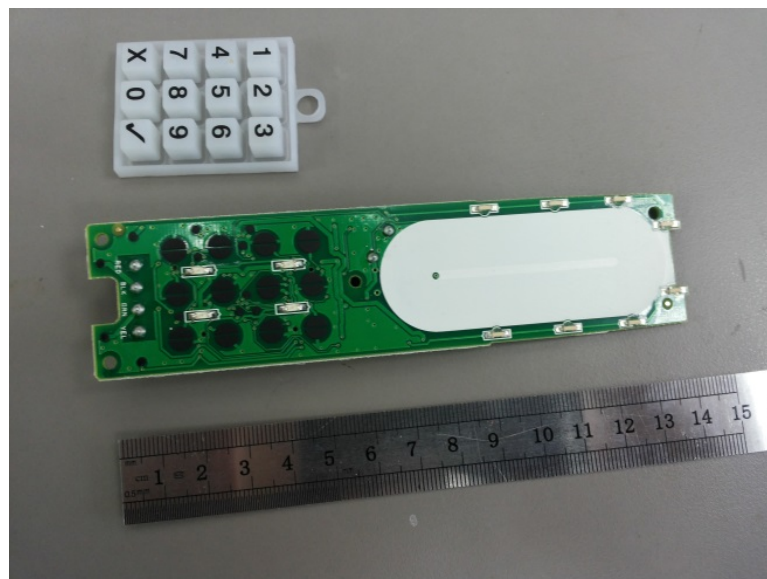



Test specification:		RSS-Gen, Section 4.6.1, Occupied bandwidth	
Test procedure:		ANSI C63.4, Section 13.1.7	
Test mode:		Compliance	
Date(s):		30-Jul-14	
Temperature: 26 °C		Air Pressure: 1008 hPa	
Remarks:		Verdict: PASS	
		Relative Humidity: 51 %	
		Power Supply: 12 VDC	

7.3 Occupied bandwidth test

7.3.1 General

This test was performed to measure transmitter occupied bandwidth not specified by the standard.

7.3.2 Test procedure

7.3.2.1 The EUT was set up as shown in Figure 7.3.1, energized and its proper operation was checked.

7.3.2.2 The EUT was set to transmit modulated carrier at maximum data rate.

7.3.2.3 The transmitter bandwidth was measured with spectrum analyzer as frequency delta between reference points on modulation envelope and provided in Table 7.3.1 and the associated plots.

Figure 7.3.1 Occupied bandwidth test setup





HERMON LABORATORIES

Test specification: RSS-Gen, Section 4.6.1, Occupied bandwidth	
Test procedure:	ANSI C63.4, Section 13.1.7
Test mode:	Compliance
Date(s):	30-Jul-14
Temperature: 26 °C	Air Pressure: 1008 hPa
Relative Humidity: 51 %	Power Supply: 12 VDC
Remarks:	

Table 7.3.1 Occupied bandwidth test results

DETECTOR USED: Peak hold
 RESOLUTION BANDWIDTH: 1 kHz
 VIDEO BANDWIDTH: 3 kHz
 MODULATION ENVELOPE REFERENCE POINTS: 20 dBc / 99%
 MODULATION: RF ID
 MODULATING SIGNAL: ID code

Carrier frequency, kHz	Occupied bandwidth 20 dBc, kHz	Occupied bandwidth 99%, kHz	Margin, kHz	Verdict
127.49	2.546	2.1585	NA	Tested

Reference numbers of test equipment used

HL 3818								
---------	--	--	--	--	--	--	--	--

Full description is given in Appendix A.



HERMON LABORATORIES

Test specification: RSS-Gen, Section 4.6.1, Occupied bandwidth			
Test procedure: ANSI C63.4, Section 13.1.7			
Test mode: Compliance	Verdict: PASS		
Date(s): 30-Jul-14			
Temperature: 26 °C	Air Pressure: 1008 hPa	Relative Humidity: 51 %	Power Supply: 12 VDC
Remarks:			

Plot 7.3.1 Occupied bandwidth test result

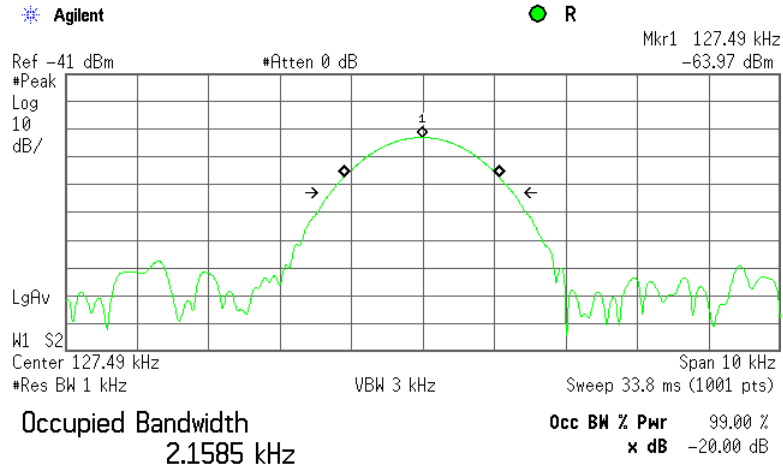

Transmit Freq Error -17.781 Hz
Occupied Bandwidth 2.546 kHz*



Test specification:		Section 15.207(a) / RSS-Gen, Section 7.2.4, Conducted emission	
Test procedure:		ANSI C63.4, Section 13.1.3	
Test mode:		Compliance	
Date(s):		29-Jul-14	
Temperature: 25 °C		Air Pressure: 1010 hPa	
		Relative Humidity: 42 %	
		Power Supply: 120 VAC	
Remarks:			

7.4 Conducted emissions

7.4.1 General

This test was performed to measure common mode conducted emissions at the EUT power port. The specification test limits are given in Table 7.4.1.

Table 7.4.1 Limits for conducted emissions

Frequency, MHz	Class B limit, dB(μV)		Class A limit, dB(μV)	
	QP	AVRG	QP	AVRG
0.15 - 0.5	66 - 56*	56 - 46*	79	66
0.5 - 5.0	56	46	73	60
5.0 - 30	60	50	73	60

* The limit decreases linearly with the logarithm of frequency.

7.4.2 Test procedure

7.4.2.1 The EUT was set up as shown in Figure 7.4.1, energized and the EUT performance was checked.

7.4.2.2 The measurements were performed at the EUT power terminals with the LISN, connected to the EMI receiver in the frequency range referred to in Table 7.4.2. The unused coaxial connector of the LISN was terminated with 50 Ohm.

7.4.2.3 The position of the EUT cables was varied to find the highest emission.

7.4.2.4 The worst test results with respect to the limits were recorded in Table 7.4.2 and shown in the associated plots.

Figure 7.4.1 Setup for conducted emission measurements, table-top EUT

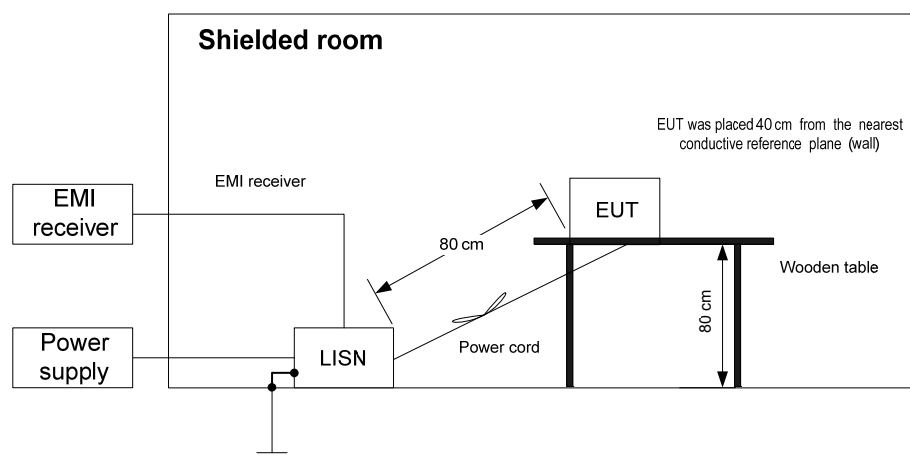



Test specification:		Section 15.207(a) / RSS-Gen, Section 7.2.4, Conducted emission	
Test procedure:		ANSI C63.4, Section 13.1.3	
Test mode:		Compliance	
Date(s):		29-Jul-14	
Temperature: 25 °C		Air Pressure: 1010 hPa	
		Relative Humidity: 42 %	
		Power Supply: 120 VAC	
Remarks:			

Table 7.4.2 Conducted emission test results

LINE: AC mains
 EUT OPERATING MODE: Transmit
 EUT SET UP: TABLE-TOP
 TEST SITE: SHIELDED ROOM
 FREQUENCY RANGE: 150 kHz - 30 MHz
 RESOLUTION BANDWIDTH: 9 kHz

Frequency, MHz	Peak emission, dB(µV)	Quasi-peak			Average			Line ID	Verdict
		Measured emission, dB(µV)	Limit, dB(µV)	Margin, dB*	Measured emission, dB(µV)	Limit, dB(µV)	Margin, dB*		
0.173131	53.59	46.06	64.87	-18.81	15.97	54.87	-38.90	L1	Pass
0.192289	50.39	43.10	63.95	-20.85	13.27	53.95	-40.68		
0.223774	45.02	38.28	62.74	-24.46	9.74	52.74	-43.00		
15.999348	31.84	31.22	60.00	-28.78	31.72	50.00	-18.28		
0.150950	56.82	49.15	65.95	-16.80	18.34	55.95	-37.61	L2	Pass
0.179030	54.29	46.08	64.58	-18.50	15.43	54.58	-39.15		
0.205336	50.06	41.85	63.45	-21.60	12.62	53.45	-40.83		
0.255288	44.44	35.46	61.63	-26.17	6.98	51.63	-44.65		

*- Margin = Measured emission - specification limit.

Reference numbers of test equipment used

HL 2888	HL 3612	HL 4778				
---------	---------	---------	--	--	--	--

Full description is given in Appendix A.



Test specification: Section 15.207(a) / RSS-Gen, Section 7.2.4, Conducted emission			
Test procedure: ANSI C63.4, Section 13.1.3			
Test mode: Compliance	Verdict: PASS		
Date(s): 29-Jul-14			
Temperature: 25 °C	Air Pressure: 1010 hPa	Relative Humidity: 42 %	Power Supply: 120 VAC
Remarks:			

Plot 7.4.1 Conducted emission measurements

LINE: L1
EUT OPERATING MODE: Transmit
LIMIT: QUASI-PEAK, AVERAGE
DETECTOR: PEAK

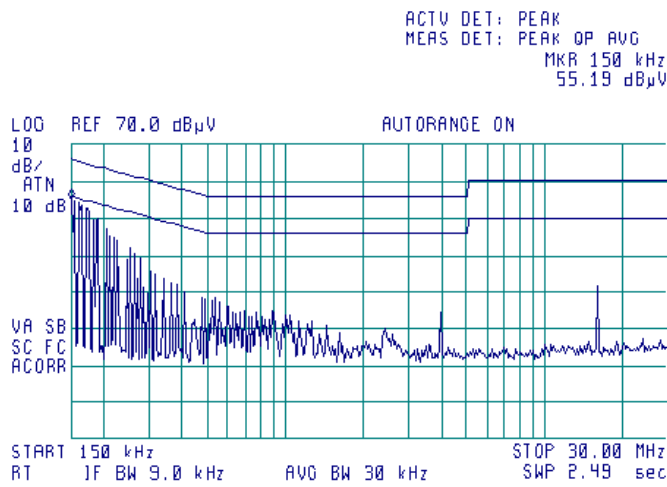

Plot 7.4.2 Conducted emission measurements

LINE: L2
EUT OPERATING MODE: Transmit
LIMIT: QUASI-PEAK, AVERAGE
DETECTOR: PEAK

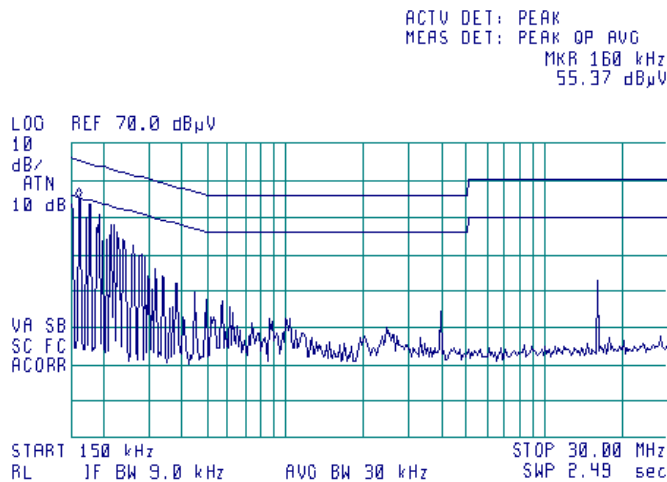



Test specification:		Section 15.107, Conducted emission at AC power port	
Test procedure:		ANSI C63.4, Sections 11.5 and 12.1.3	
Test mode:		Compliance	
Date(s):		29-Jul-14	
Temperature: 25 °C		Air Pressure: 1010 hPa	
Relative Humidity: 44 %		Power Supply: 120 VAC	
Remarks:			

8 Unintentional emissions

8.1 Conducted emissions

8.1.1 General

This test was performed to measure common mode conducted emissions at the mains power port. Specification test limits are given in Table 8.1.1.

Table 8.1.1 Limits for conducted emissions

Frequency, MHz	Class B limit, dB(μV)		Class A limit, dB(μV)	
	QP	AVRG	QP	AVRG
0.15 - 0.5	66 - 56*	56 - 46*	79	66
0.5 - 5.0	56	46	73	60
5.0 - 30	60	50	73	60

* - The limit decreases linearly with the logarithm of frequency.

8.1.2 Test procedure

8.1.2.1 The EUT was set up as shown in Figure 8.1.1 and associated photographs, energized and the performance check was conducted.

8.1.2.2 The measurements were performed at power terminals with the LISN, connected to a spectrum analyzer while unused coaxial connector of the LISN was terminated with 50 Ohm.

8.1.2.3 The position of the device cables was varied to determine maximum emission level.

8.1.2.4 The worst test results (the lowest margins) were recorded in Table 8.1.2 and shown in the associated plots.

Figure 8.1.1 Setup for conducted emission measurements, table-top equipment

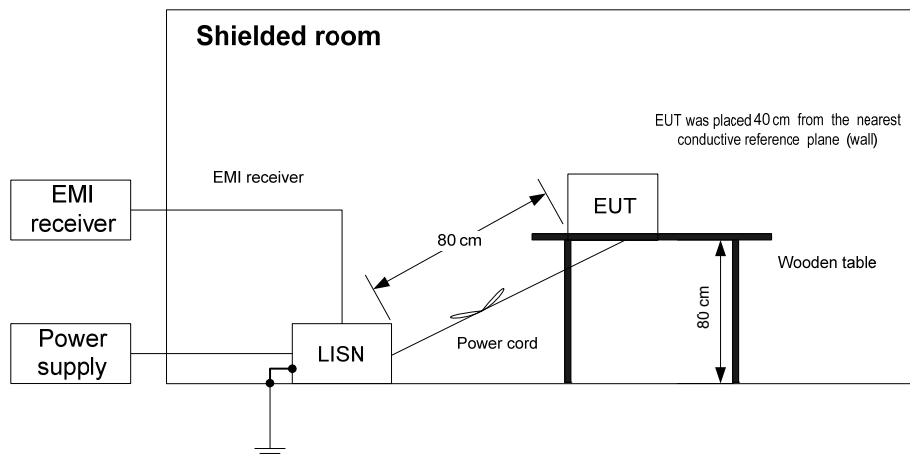



Test specification:	Section 15.107, Conducted emission at AC power port		
Test procedure:	ANSI C63.4, Sections 11.5 and 12.1.3		
Test mode:	Compliance	Verdict:	PASS
Date(s):	29-Jul-14		
Temperature: 25 °C	Air Pressure: 1010 hPa	Relative Humidity: 44 %	Power Supply: 120 VAC
Remarks:			

Photograph 8.1.1 Setup for conducted emission measurements



Photograph 8.1.2 Setup for conducted emission measurements





Test specification:		Section 15.107, Conducted emission at AC power port	
Test procedure:		ANSI C63.4, Sections 11.5 and 12.1.3	
Test mode:		Compliance	
Date(s):		29-Jul-14	
Temperature: 25 °C		Air Pressure: 1010 hPa	
Relative Humidity: 44 %		Power Supply: 120 VAC	
Remarks:			

Table 8.1.2 Conducted emission test results

LINE: AC mains
EUT OPERATING MODE: Standby/Receive
EUT SET UP: TABLE-TOP
TEST SITE: SHIELDED ROOM
FREQUENCY RANGE: 150 kHz - 30 MHz
RESOLUTION BANDWIDTH: 9 kHz

Frequency, MHz	Peak emission, dB(μV)	Quasi-peak			Average			Line ID	Verdict
		Measured emission, dB(μV)	Limit, dB(μV)	Margin, dB*	Measured emission, dB(μV)	Limit, dB(μV)	Margin, dB*		
0.173131	53.59	46.06	64.87	-18.81	15.97	54.87	-38.90	L1	Pass
0.192289	50.39	43.10	63.95	-20.85	13.27	53.95	-40.68		
0.223774	45.02	38.28	62.74	-24.46	9.74	52.74	-43.00		
15.999348	31.84	31.22	60.00	-28.78	31.72	50.00	-18.28		
0.150950	56.82	49.15	65.95	-16.80	18.34	55.95	-37.61	L2	Pass
0.179030	54.29	46.08	64.58	-18.50	15.43	54.58	-39.15		
0.205336	50.06	41.85	63.45	-21.60	12.62	53.45	-40.83		
0.255288	44.44	35.46	61.63	-26.17	6.98	51.63	-44.65		

*- Margin = Measured emission - specification limit.

Reference numbers of test equipment used

HL 2888	HL 3612	HL 4778				
---------	---------	---------	--	--	--	--

Full description is given in Appendix A.



HERMON LABORATORIES

Test specification:		Section 15.107, Conducted emission at AC power port	
Test procedure:		ANSI C63.4, Sections 11.5 and 12.1.3	
Test mode:		Compliance	
Date(s):		29-Jul-14	
Temperature: 25 °C		Air Pressure: 1010 hPa	
Relative Humidity: 44 %		Power Supply: 120 VAC	
Remarks:			

Plot 8.1.1 Conducted emission measurements

LINE: L1
LIMIT: Class B
EUT OPERATING MODE: Standby/Receive
LIMIT: QUASI-PEAK, AVERAGE
DETECTOR: PEAK

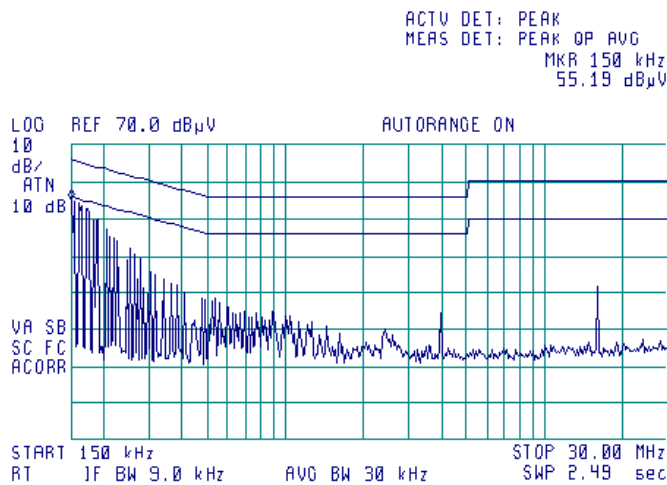

Plot 8.1.2 Conducted emission measurements

LINE: L2
LIMIT: Class B
EUT OPERATING MODE: Standby/Receive
LIMIT: QUASI-PEAK, AVERAGE
DETECTOR: PEAK

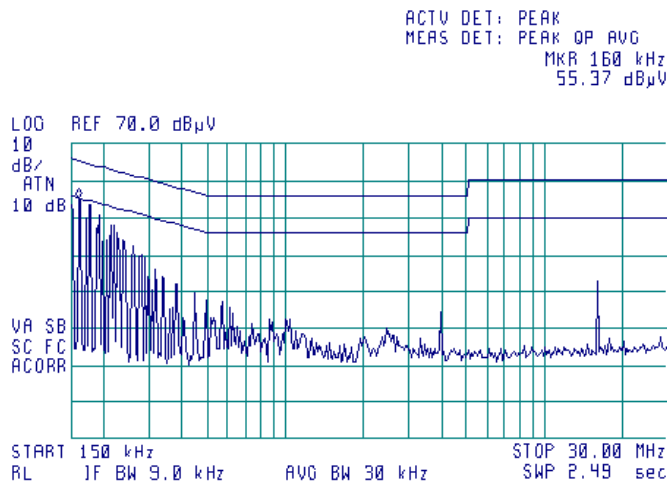



Test specification:	FCC Part 15, Section 109 / RSS-Gen, Section 6.1/ ICES-003 Section 6.2, Class B, Radiated emission		
Test procedure:	ANSI C63.4, Sections 11.6 and 12.1.4		
Test mode:	Compliance	Verdict:	PASS
Date(s):	28-Jul-14		
Temperature: 25 °C	Air Pressure: 1010 hPa	Relative Humidity: 42 %	Power Supply: 12 VDC
Remarks:			

8.2 Radiated emission measurements

8.2.1 General

This test was performed to measure radiated emissions from the EUT enclosure. Specification test limits are given in Table 8.2.1, Table 8.2.2.

Table 8.2.1 Radiated emission limits according to FCC Part 15, Section 109 and ICES-003, Section 6.2

Frequency, MHz	Class B limit, dB(µV/m)		Class A limit, dB(µV/m)	
	10 m distance	3 m distance	10 m distance	3 m distance
30 - 88	29.5*	40.0	39.0	49.5*
88 - 216	33.0*	43.5	43.5	54.0*
216 - 960	35.5*	46.0	46.4	56.9*
960 - 5 th harmonic**	43.5*	54.0	49.5	60.0*

* - The limit for test distance other than specified was calculated using the inverse linear distance extrapolation factor as follows: $Lim_{S_2} = Lim_{S_1} + 20 \log(S_1/S_2)$, where S_1 and S_2 – standard defined and test distance respectively in meters.

Table 8.2.2 Radiated emission limits according to RSS-Gen, Section 6.1

Frequency, MHz	Field strength limit at 3 m test distance, dB(µV/m)
30 - 88	40.0
88 - 216	43.5
216 - 960	46.0
960 - 3 rd harmonic**	54.0

** - harmonic of the highest frequency the EUT generates, uses, operates or tunes to.

8.2.2 Test procedure

8.2.2.1 The EUT was set up as shown in Figure 8.2.1 and associated photograph/s, energized and the performance check was conducted.

8.2.2.2 The specified frequency range was investigated with biconilog antenna connected to EMI receiver. To find maximum radiation the turntable was rotated 360°, the measuring antenna height was changed from 1 to 4 m, its polarization was switched from vertical to horizontal and the EUT cables position was varied.

8.2.2.3 The worst test results (the lowest margins) were provided in the associated tables and plots.



Test specification:	FCC Part 15, Section 109 / RSS-Gen, Section 6.1/ ICES-003 Section 6.2, Class B, Radiated emission		
Test procedure:	ANSI C63.4, Sections 11.6 and 12.1.4		
Test mode:	Compliance	Verdict:	PASS
Date(s):	28-Jul-14		
Temperature: 25 °C	Air Pressure: 1010 hPa	Relative Humidity: 42 %	Power Supply: 12 VDC
Remarks:			

Figure 8.2.1 Setup for radiated emission measurements in anechoic chamber, table-top equipment

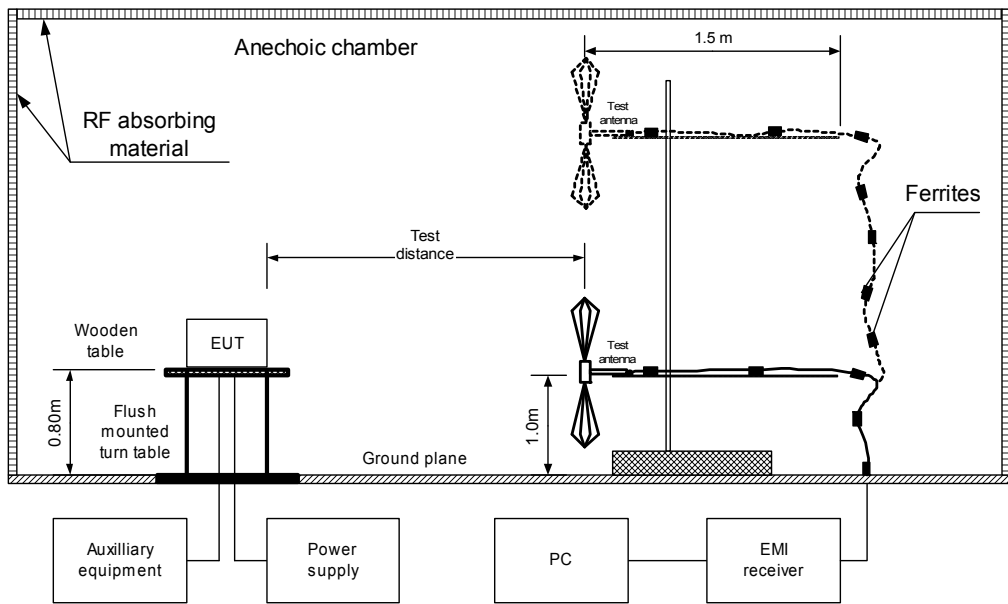

Photograph 8.2.1 Setup for radiated emission measurements

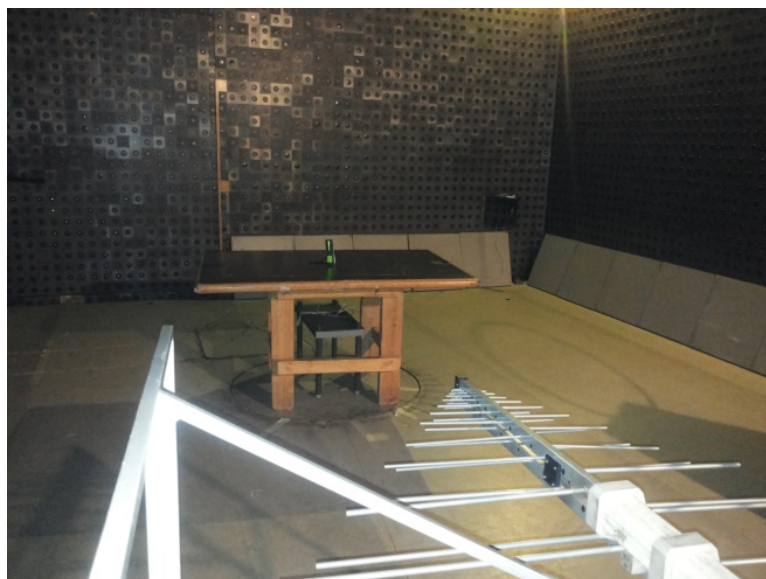



Test specification:	FCC Part 15, Section 109 / RSS-Gen, Section 6.1/ ICES-003 Section 6.2, Class B, Radiated emission		
Test procedure:	ANSI C63.4, Sections 11.6 and 12.1.4		
Test mode:	Compliance	Verdict:	PASS
Date(s):	28-Jul-14		
Temperature: 25 °C	Air Pressure: 1010 hPa	Relative Humidity: 42 %	Power Supply: 12 VDC
Remarks:			

Photograph 8.2.2 Setup for radiated emission measurements, EUT close view





Test specification:	FCC Part 15, Section 109 / RSS-Gen, Section 6.1/ ICES-003 Section 6.2, Class B, Radiated emission		
Test procedure:	ANSI C63.4, Sections 11.6 and 12.1.4		
Test mode:	Compliance	Verdict: PASS	
Date(s):	28-Jul-14		
Temperature: 25 °C	Air Pressure: 1010 hPa	Relative Humidity: 42 %	Power Supply: 12 VDC
Remarks:			

Table 8.2.3 Radiated emission test results

EUT SET UP: TABLE-TOP
LIMIT: Class B
EUT OPERATING MODE: Stand-by / Receive
TEST SITE: SEMI ANECHOIC CHAMBER
TEST DISTANCE: 3 m
FREQUENCY RANGE: 30 MHz – 1000 MHz
RESOLUTION BANDWIDTH: 120 kHz

Frequency, MHz	Peak emission, dB(µV/m)	Quasi-peak			Antenna polarization	Antenna height, m	Turn-table position**, degrees	Verdict
		Measured emission, dB(µV/m)	Limit, dB(µV/m)	Margin, dB*				
33.507	35.38	31.42	40.0	-8.58	Vertical	1.0	34	Pass
38.602	40.22	37.69	40.0	-2.31	Vertical	1.0	0	
44.033	33.31	29.58	40.0	-10.42	Vertical	1.0	345	
47.612	32.26	29.63	40.0	-10.37	Vertical	1.0	123	

Reference numbers of test equipment used

HL 0604	HL 0521	HL 4353	HL 4722				
---------	---------	---------	---------	--	--	--	--

Full description is given in Appendix A.



HERMON LABORATORIES

Test specification:	FCC Part 15, Section 109 / RSS-Gen, Section 6.1/ ICES-003 Section 6.2, Class B, Radiated emission		
Test procedure:	ANSI C63.4, Sections 11.6 and 12.1.4		
Test mode:	Compliance	Verdict:	PASS
Date(s):	28-Jul-14		
Temperature: 25 °C	Air Pressure: 1010 hPa	Relative Humidity: 42 %	Power Supply: 12 VDC
Remarks:			

Plot 8.2.1 Radiated emission measurements in 30 - 1000 MHz range, vertical antenna polarization

TEST SITE: Semi anechoic chamber
LIMIT: Class B
TEST DISTANCE: 3 m

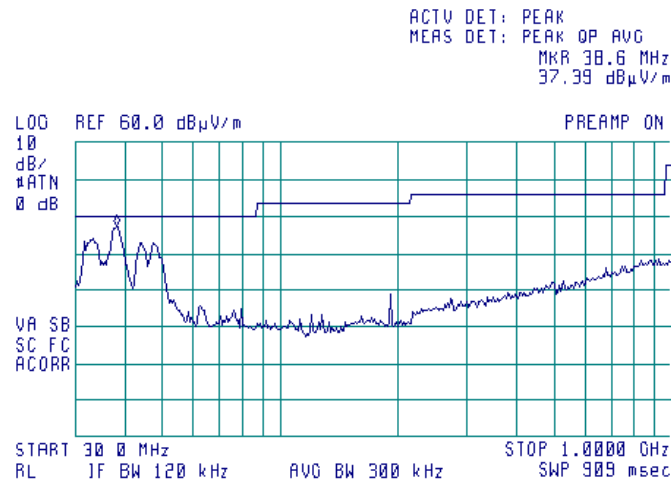

Plot 8.2.2 Radiated emission measurements in 30 - 1000 MHz range, horizontal antenna polarization

TEST SITE: Semi anechoic chamber
LIMIT: Class B
TEST DISTANCE: 3 m

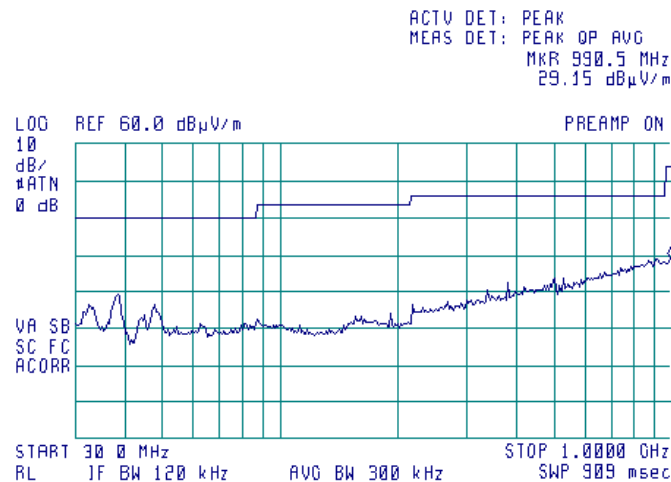

**9 APPENDIX A Test equipment and ancillaries used for tests**

HL No	Description	Manufacturer	Model	Ser. No.	Last Cal./ Check	Due Cal./ Check
0446	Antenna, Loop, Active, 10 kHz - 30 MHz	EMCO	6502	2857	21-Jan-14	21-Jan-15
0521	EMI Receiver (Spectrum Analyzer) with RF filter section 9 kHz-6.5 GHz	Hewlett Packard	8546A	3617A 00319, 3448A002 53	28-Oct-13	28-Oct-14
0604	Antenna BiconiLog Log-Periodic/T Bow-TIE, 26 - 2000 MHz	EMCO	3141	9611-1011	22-May-14	22-May-15
2888	LISN Two-line V-Network 50 Ohm / 50 uH + 5 Ohm, 16A, MIL STD 461E, CISPR 16-1	Rolf Heine	NNB-2/16Z	02/10018	24-Mar-14	24-Mar-15
3612	Cable RF, 17.5 m, N type-N type	Teldor	RG-214/U	NA	05-Dec-13	05-Dec-14
3818	PSA Series Spectrum Analyzer, 3 Hz- 44 GHz	Agilent Technologies	E4446A	MY482502 88	20-May-14	20-May-15
4353	Low Loss Armored Test Cable, DC - 18 GHz, 6.2 m, N type-M/N type-M	MegaPhase	NC29-N1N1-244	12025101 003	16-Mar-14	16-Mar-15
4722	Low Loss Armored Test Cable, DC - 18 GHz, 6.2 m, N type-M/N type-M	MegaPhase	NC29-N1N1-244	51228701 001	01-May-14	01-May-15
4778	EMI Receiver, 9 kHz - 2.9 GHz, System: HL1431, HL4777	Hewlett Packard	8542E	30807A00 262, 3427A001 23	06-Nov-13	06-Nov-14

**10 APPENDIX B Measurement uncertainties****Expanded uncertainty at 95% confidence in Hermon Labs EMC measurements**

Test description	Expanded uncertainty
Conducted emissions with LISN	9 kHz to 150 kHz: ± 3.9 dB 150 kHz to 30 MHz: ± 3.8 dB
Radiated emissions at 3 m measuring distance Horizontal polarization Vertical polarization	Biconilog antenna: ± 5.3 dB Biconical antenna: ± 5.0 dB Log periodic antenna: ± 5.3 dB Double ridged horn antenna: ± 5.3 dB Biconilog antenna: ± 6.0 dB Biconical antenna: ± 5.7 dB Log periodic antenna: ± 6.0 dB Double ridged horn antenna: ± 6.0 dB
Conducted emissions at RF antenna connector	9 kHz to 2.9 GHz: ± 2.6 dB 2.9 GHz to 6.46 GHz: ± 3.5 dB 6.46 GHz to 13.2 GHz: ± 4.3 dB 13.2 GHz to 22.0 GHz: ± 5.0 dB 22.0 GHz to 26.8 GHz: ± 5.5 dB 26.8 GHz to 40.0 GHz: ± 4.8 dB
Duty cycle, timing (Tx ON / OFF) and average factor measurements	± 1.0 %
Occupied bandwidth	± 8.0 %

Hermon Laboratories is accredited by A2LA for calibration according to present requirements of ISO/IEC 17025 and NCSL Z540-1. The accreditation is granted to perform calibration of parameters that are listed in the Scope of Hermon Laboratories Accreditation.

Hermon Laboratories calibrates its reference and transfer standards by calibration laboratories accredited to ISO/IEC 17025 by a mutually recognized Accreditation Body or by a recognized national metrology institute. All reference and transfer standards used in the calibration system are traceable to national or international standards.

In-house calibration of all test and measurement equipment is performed on a regular basis according to Hermon Laboratories calibration procedures, manufacturer calibration/verification procedures or procedures defined in the relevant standards. The Hermon Laboratories test and measurement equipment is calibrated within the tolerances specified by the manufacturers and/or by the relevant standards.

11 APPENDIX C Test laboratory description

Tests were performed at Hermon Laboratories Ltd., which is a fully independent, private, EMC, safety, environmental and telecommunication testing facility.

Hermon Laboratories is listed by the Federal Communications Commission (USA) for all parts of Code of Federal Regulations 47 (CFR 47), Registration Numbers 90624 for OATS and 90623 for the anechoic chamber; by Industry Canada for electromagnetic emissions (file numbers IC 2186A-1 for OATS, IC 2186A-2 for anechoic chamber, IC 2186A-3 for full-anechoic chamber for RE measurements above 1 GHz), certified by VCCI, Japan (the registration numbers are R-808 for OATS, R-1082 for anechoic chamber, G-27 for full-anechoic chamber for RE measurements above 1 GHz, C-845 for conducted emissions site, T-1606 for conducted emissions at telecommunication ports), has a status of a Telefication - Listed Testing Laboratory, Certificate No. L138/00. The laboratory is accredited by American Association for Laboratory Accreditation (USA) according to ISO/IEC 17025 for electromagnetic compatibility, product safety, telecommunications testing and environmental simulation (for exact scope please refer to Certificate No. 839.01). The FCC Designation Number is US1003.

Address: P.O. Box 23, Binyamina 30500, Israel.
Telephone: +972 4628 8001
Fax: +972 4628 8277
e-mail: mail@hermonlabs.com
website: www.hermonlabs.com

Person for contact: Mr. Alex Usoskin, CEO.

12 APPENDIX D Specification references

FCC 47CFR part 15: 2013	Radio Frequency Devices
ANSI C63.2: 1996	American National Standard for Instrumentation-Electromagnetic Noise and Field Strength, 10 kHz to 40 GHz-Specifications
ANSI C63.4: 2003	American National Standard for Methods of Measurement of Radio-Noise Emissions from Low-Voltage Electrical and Electronic Equipment in the Range of 9 kHz to 40 GHz
RSS-210 Issue 8: 2010	Low Power Licence- Exempt Radiocommunication Devices
RSS-Gen Issue 3: 2010	General Requirements and Information for the Certification of Radiocommunication Equipment
ICES-003 issue 5:2012	Information Technology Equipment (ITE) – Limits and methods of measurement



13 APPENDIX E Test equipment correction factors

Antenna factor
Active loop antenna
Model 6502, S/N 2857, HL 0446

Frequency, MHz	Magnetic antenna factor, dB	Electric antenna factor, dB
0.009	-32.8	18.7
0.010	-33.8	17.7
0.020	-38.3	13.2
0.050	-41.1	10.4
0.075	-41.3	10.2
0.100	-41.6	9.9
0.150	-41.7	9.8
0.250	-41.6	9.9
0.500	-41.8	9.8
0.750	-41.9	9.7
1.000	-41.4	10.1
2.000	-41.5	10.0
3.000	-41.4	10.2
4.000	-41.4	10.1
5.000	-41.5	10.1
10.000	-41.9	9.6
15.000	-41.9	9.6
20.000	-42.2	9.3
25.000	-42.8	8.7
30.000	-44.0	7.5

Antenna factor in dB(1/m) is to be added to receiver meter reading in dB(μ V) to convert it into field intensity in dB(μ V/m).



Antenna factor
Biconilog antenna EMCO Model 3141
Ser.No.1011, HL 0604

Frequency, MHz	Antenna factor, dB(1/m)	Frequency, MHz	Antenna factor, dB(1/m)	Frequency, MHz	Antenna factor, dB(1/m)
26	7.8	580	20.6	1320	27.8
28	7.8	600	21.3	1340	28.3
30	7.8	620	21.5	1360	28.2
40	7.2	640	21.2	1380	27.9
60	7.1	660	21.4	1400	27.9
70	8.5	680	21.9	1420	27.9
80	9.4	700	22.2	1440	27.8
90	9.8	720	22.2	1460	27.8
100	9.7	740	22.1	1480	28.0
110	9.3	760	22.3	1500	28.5
120	8.8	780	22.6	1520	28.9
130	8.7	800	22.7	1540	29.6
140	9.2	820	22.9	1560	29.8
150	9.8	840	23.1	1580	29.6
160	10.2	860	23.4	1600	29.5
170	10.4	880	23.8	1620	29.3
180	10.4	900	24.1	1640	29.2
190	10.3	920	24.1	1660	29.4
200	10.6	940	24.0	1680	29.6
220	11.6	960	24.1	1700	29.8
240	12.4	980	24.5	1720	30.3
260	12.8	1000	24.9	1740	30.8
280	13.7	1020	25.0	1760	31.1
300	14.7	1040	25.2	1780	31.0
320	15.2	1060	25.4	1800	30.9
340	15.4	1080	25.6	1820	30.7
360	16.1	1100	25.7	1840	30.6
380	16.4	1120	26.0	1860	30.6
400	16.6	1140	26.4	1880	30.6
420	16.7	1160	27.0	1900	30.6
440	17.0	1180	27.0	1920	30.7
460	17.7	1200	26.7	1940	30.9
480	18.1	1220	26.5	1960	31.2
500	18.5	1240	26.5	1980	31.6
520	19.1	1260	26.5	2000	32.0
540	19.5	1280	26.6		
560	19.8	1300	27.0		

Antenna factor in dB(1/m) is to be added to receiver meter reading in dB(μV) to convert it into field strength in dB(μV/m).

Correction factor
Line impedance stabilization network
Model NNB-2/16Z, Rolf Heine, HL 2888

Frequency, kHz	Correction factor, dB	
	L	N
150	21.92	21.74
170	21.52	21.36
200	21.06	20.85
250	20.88	20.68
300	20.92	20.70
350	20.96	20.77
400	20.96	20.74
500	20.92	20.69
600	20.85	20.63
700	20.78	20.58
800	20.73	20.52
900	20.68	20.50
1000	20.67	20.45
1200	20.61	20.43
1500	20.56	20.33
2000	20.54	20.32
2500	20.51	20.33
3000	20.53	20.29
4000	20.46	20.30
5000	20.53	20.33
7000	20.54	20.32
10000	20.62	20.36
15000	20.78	20.49
20000	20.94	20.63
30000	21.37	20.95

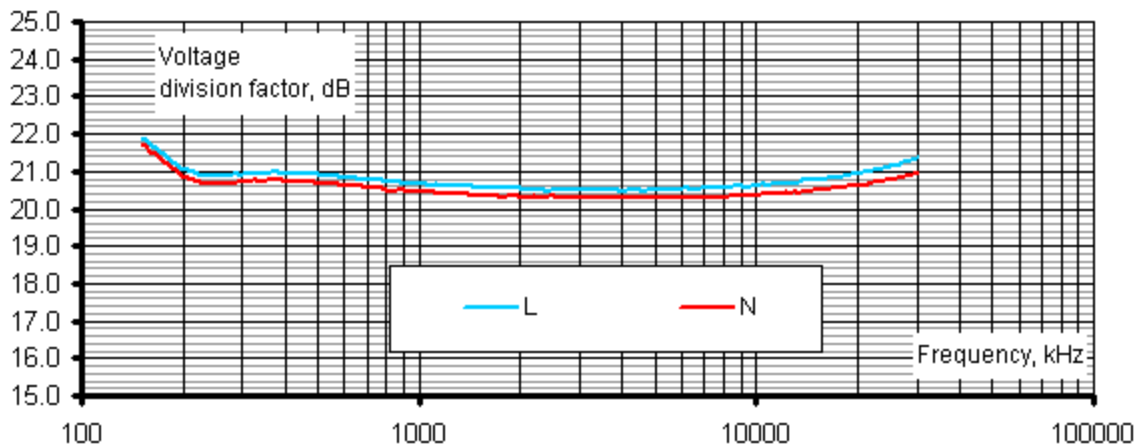



Cable loss
Cable coaxial, RG-214/U, N type-N type, 17 m
Teldor, HL 3612

Frequency, MHz	Cable loss, dB
0.1	0.05
0.5	0.07
1	0.10
3	0.22
5	0.29
10	0.39
30	0.68
50	0.90
100	1.27
150	1.58
200	1.80
250	2.12
300	2.36
350	2.60
400	2.82
450	2.99
500	3.23
550	3.40
600	3.56
650	3.71
700	3.90
750	4.04
800	4.23
850	4.39
900	4.55
950	4.65
1000	4.79



Cable loss
Low Loss Armored Test Cable, MegaPhase, 18 GHz, 6.2 m, N type-M/N type-M,
NC29-N1N1-244S/N 12025101 003,
HL 4353

Frequency, MHz	Cable loss, dB	Frequency, MHz	Cable loss, dB
50	0.20	9000	2.71
100	0.27	9500	2.81
300	0.47	10000	2.90
500	0.61	10500	2.97
1000	0.87	11000	3.06
1500	1.07	11500	3.13
2000	1.24	12000	3.20
2500	1.39	12500	3.26
3000	1.53	13000	3.34
3500	1.65	13500	3.39
4000	1.77	14000	3.47
4500	1.89	14500	3.54
5000	1.99	15000	3.62
5500	2.07	15500	3.69
6000	2.20	16000	3.76
6500	2.30	16500	3.83
7000	2.39	17000	3.86
7500	2.51	17500	3.94
8000	2.58	18000	4.02
8500	2.65		



Cable loss
Low Loss Armored Test Cable, MegaPhase, 18 GHz, 6.2 m, N type-M/N type-M,
NC29-N1N1-244, S/N 51228701 001
HL 4722

Frequency, MHz	Cable loss, dB	Frequency, MHz	Cable loss, dB
50	0.22	9000	2.93
100	0.30	9500	3.06
300	0.52	10000	3.16
500	0.66	10500	3.20
1000	0.93	11000	3.34
1500	1.15	11500	3.39
2000	1.33	12000	3.48
2500	1.49	12500	3.55
3000	1.64	13000	3.66
3500	1.77	13500	3.75
4000	1.90	14000	3.76
4500	2.03	14500	3.87
5000	2.17	15000	3.98
5500	2.30	15500	4.01
6000	2.39	16000	4.14
6500	2.51	16500	4.15
7000	2.59	17000	4.32
7500	2.67	17500	4.36
8000	2.76	18000	4.38
8500	2.84		



14 APPENDIX F Abbreviations and acronyms

A	ampere
AC	alternating current
A/m	ampere per meter
AVRG	average (detector)
cm	centimeter
dB	decibel
dBm	decibel referred to one milliwatt
dB(μ V)	decibel referred to one microvolt
dB(μ V/m)	decibel referred to one microvolt per meter
dB(μ A)	decibel referred to one microampere
DC	direct current
EIRP	equivalent isotropically radiated power
ERP	effective radiated power
EUT	equipment under test
F	frequency
GHz	gigahertz
GND	ground
H	height
HL	Hermon laboratories
Hz	hertz
k	kilo
kHz	kilohertz
LO	local oscillator
m	meter
MHz	megahertz
min	minute
mm	millimeter
ms	millisecond
μ s	microsecond
NA	not applicable
OATS	open area test site
Ω	Ohm
PS	power supply
ppm	part per million (10^{-6})
QP	quasi-peak
RE	radiated emission
RF	radio frequency
rms	root mean square
Rx	receive
s	second
T	temperature
Tx	transmit
V	volt

END OF DOCUMENT