	<b>Test Report Serial No.:</b>	060605KBC-T646-E15W	<b>Report Revision No.:</b>	Rev. 0
	<b>Test Date(s):</b>	4Jul05 - 20Jul05	<b>Report Issue Date:</b>	8Dec05
	<b>Test Standard(s):</b>	FCC 47 CFR §15.247	Industry Canada RSS-210 Issue 5	
	<b>Lab Registration(s):</b>	FCC Lab Reg. # 714830	Industry Canada Lab File #3874	

## EMC TEST REPORT

FOR

**ITRONIX CORPORATION**

**MODEL: IX325A775IWLBT**

**RUGGED TABLET PC**

INCLUDING

**802.11b/g DSSS WLAN MINI-PCI CARD**

WITH

**DUAL INTERNAL PIFA ANTENNA**

**FCC ID: KBCIX325A775IWLBT**

**IC: 1943A-IX325e**

Test Report Serial Number

**060605KBC-T646-E15W  
Revision 0**

Test Report Issue Date

**December 08, 2005**

Test Lab

**Celltech Compliance Testing & Engineering Lab  
(Celltech Labs Inc.)  
1955 Moss Court  
Kelowna, BC  
Canada  
V1Y 9L3**

	<b>Test Report Serial No.:</b>	060605KBC-T646-E15W	<b>Report Revision No.:</b>	Rev. 0
	<b>Test Date(s):</b>	4Jul05 - 20Jul05	<b>Report Issue Date:</b>	8Dec05
	<b>Test Standard(s):</b>	FCC 47 CFR §15.247	Industry Canada RSS-210 Issue 5	
	<b>Lab Registration(s):</b>	FCC Lab Reg. # 714830	Industry Canada Lab File #3874	

## DECLARATION OF COMPLIANCE

<b>Test Lab</b>		<b>CELLTECH LABS INC.</b> Testing and Engineering Services 1955 Moss Court Kelowna, B.C. Canada V1Y 9L3  <b>Phone:</b> 250-448-7047 <b>Fax:</b> 250-448-7048 <b>e-mail:</b> info@celltechlabs.com <b>web site:</b> www.celltechlabs.com		<b>Applicant</b>		<b>ITRONIX CORPORATION</b> 801 South Stevens Street Spokane, WA 99204 United States	
<b>Lab Registration No.(s):</b>	FCC:	714830	IC:	3874			
<b>Rule Part(s):</b>	FCC:	§15.247; §2.1091; §1.1310	IC:	RSS-210 Issue 5 - A1. 11/30/02			
<b>Device Classification:</b>	FCC:	Digital Transmission System (DTS)	IC:	Low Power Licence-Exempt Transmitter			
<b>Device Identification:</b>	FCC ID:	KBCIX325A775IWLBT	IC:	1943A-IX325e			
<b>DUT Description:</b>							
<b>Model:</b>	IX325A775IWLBT						
<b>Device Description:</b>	Rugged Tablet PC						
<b>Internal Transmitter(s):</b>	Intel PRO2200BG 802.11b/g 2.4 GHz DSSS WLAN Mini-PCI Card						
<b>TX Frequency Range:</b>	2412 - 2462 MHz						
<b>Max. RF Output Power:</b>	0.112 Watts - 20.49 dBm - Peak Conducted - 802.11b 0.048 Watts - 16.77 dBm - Peak Conducted - 802.11g						
<b>Modulation Type(s):</b>	OFDM with BPSK, QPSK, 16QAM, 64QAM, DBPSK, DQPSK, CCK						
<b>Antenna Type(s):</b>	Well Green Technology PIFA WLAN Dual Internal Antenna (Primary Transmit & Receive - upper right side edge of LCD Display) (Auxiliary Receive only - upper left side edge of LCD Display)						
<b>Power Source(s):</b>	Stationary: 75 Watt AC Power Adapter						
	11.1 V Internal Lithium-ion Battery, 3600 mAh (Model: T8M-E)						
	11.1 V External Second Lithium-ion Battery, 3600 mAh (Model: T8S-E)						

This wireless device has demonstrated compliance with the applicable technical standards as indicated in the measurement report and was tested in accordance with the measurement procedures specified in FCC 47 CFR Part 15C and Industry Canada RSS-210 Issue 5.

I attest to the accuracy of the data. All measurements reported herein were performed by me or were under my supervision and are correct to the best of my knowledge and belief. I assume full responsibility for the completeness of these measurements and vouch for the qualifications of all persons taking them.

This test report shall not be reproduced partially, or in full, without the prior written approval of Celltech Labs Inc. The results and statements contained in this report pertain only to the device(s) evaluated.

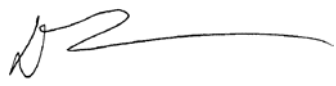
	<b>Russell Pipe</b> Senior Compliance Technologist Celltech Labs Inc.	
	<b>Alex Yuan</b> EMC Technologist Celltech Labs Inc.	
	<b>Duane M. Friesen, C.E.T.</b> EMC Manager Celltech Labs Inc.	

<b>Applicant:</b>	Itronix Corporation	<b>Model:</b>	IX325A775IWLBT	<b>FCC ID:</b>	KBCIX325A775IWLBT	<b>IC ID:</b>	1943A-IX325e
<b>IX325 Rugged Tablet PC with internal Intel PRO2200BG 802.11b/g WLAN &amp; Well Green Dual Internal Antenna</b>							
2005 Celltech Labs Inc.	This document is not to be reproduced in whole or in part without the prior written permission of Celltech Labs Inc.						Page 2 of 59

	<b>Test Report Serial No.:</b>	060605KBC-T646-E15W	<b>Report Revision No.:</b>	Rev. 0
	<b>Test Date(s):</b>	4Jul05 - 20Jul05	<b>Report Issue Date:</b>	8Dec05
	<b>Test Standard(s):</b>	FCC 47 CFR §15.247	Industry Canada RSS-210 Issue 5	
	<b>Lab Registration(s):</b>	FCC Lab Reg. # 714830	Industry Canada Lab File #3874	

## TABLE OF CONTENTS

1.0 SCOPE .....	5
2.0 REFERENCES .....	5
2.1 Normative References .....	5
TERMS AND DEFINITIONS .....	6
3.0 FACILITIES AND ACCREDITATIONS .....	7
4.0 GENERAL INFORMATION .....	7
4.1 Applicant Information .....	7
4.2 DUT Description .....	7
4.3 Co-Located Equipment .....	8
4.4 Cable Descriptions .....	8
4.5 Support Equipment .....	8
4.6 Clock Frequencies .....	9
4.7 Mode(s) of Operation Tested .....	9
4.8 Configuration Description .....	10
5.0 PASS/FAIL CRITERIA .....	10
APPENDICES .....	11
Appendix A - DUT Photographs .....	12
Appendix B - 6 dB Bandwidth Measurement .....	13
Appendix C - Peak Conducted RMS Power Measurement .....	18
Appendix D - Radiated Spurious Emissions Measurement .....	21
Appendix E - Restricted Band Emissions Measurement .....	35
Appendix F - Peak Power Spectral Density Measurement .....	50
Appendix G - Conducted Powerline Emissions Measurement .....	53
END OF DOCUMENT .....	59

## FIGURES

Figure B.6-1 - Setup Drawing .....	14
Figure C.6-1 - Setup Drawing .....	19
Figure E.6-1 - Setup Drawing .....	22
Figure F.6-1 - Setup Drawing .....	37
Figure G.6-1 - Setup Drawing .....	51
Figure H.6-1 - Setup Drawing .....	54

## PHOTOGRAPHS

Photograph A-1 - Front of IX325 Tablet PC .....	12
Photograph A-2 - Back of IX325 Tablet PC .....	12
Photograph A-3 - Edge of IX325 Tablet PC .....	12
Photograph A-4 - Side of IX325 Tablet PC .....	12
Photograph A-5 - WLAN Mini-PCI Card Location .....	12
Photograph A-6 - WLAN Dual Antenna Location .....	12
Photograph E-1 - 3115 Horn @ 3 m .....	23
Photograph E-2 - 3115 Horn with LNA/Filter @ 1m .....	23
Photograph E-3 - Waveline Horn with LNA @ 1m .....	23
Photograph F-1 - Loop Antenna (10kHz - 30 MHz) @ 3m .....	38
Photograph F-2 - Bilog Antenna (30 MHz - 1 GHz) @ 3m .....	38
Photograph F-3 - 3115 Horn (1G - 2G) @ 3 m .....	38
Photograph F-4 - 3115 Horn with LNA/Filter @ 1m .....	38
Photograph F-5 - Waveline Horn with LNA @ 1m .....	38
Photograph H-1 - AC Powerline Conducted Emission Cable Placement .....	55
Photograph H-2 - AC Powerline Conducted Emission Configuration .....	55

<b>Applicant:</b>	Itronix Corporation	<b>Model:</b>	IX325A775IWLBT	<b>FCC ID:</b>	KBCIX325A775IWLBT	<b>IC ID:</b>	1943A-IX325e
<b>IX325 Rugged Tablet PC with internal Intel PRO2200BG 802.11b/g WLAN &amp; Well Green Dual Internal Antenna</b>							
2005 Celltech Labs Inc.	This document is not to be reproduced in whole or in part without the prior written permission of Celltech Labs Inc.						Page 3 of 59



	<b>Test Report Serial No.:</b>	060605KBC-T646-E15W	<b>Report Revision No.:</b>	Rev. 0
	<b>Test Date(s):</b>	4Jul05 - 20Jul05	<b>Report Issue Date:</b>	8Dec05
	<b>Test Standard(s):</b>	FCC 47 CFR §15.247	Industry Canada RSS-210 Issue 5	
	<b>Lab Registration(s):</b>	FCC Lab Reg. # 714830	Industry Canada Lab File #3874	

TEST SUMMARY						
Appendix	Test Description	Procedure Reference	Limit Reference	Test Start Date	Test End Date	Result
<b>Referenced Standard: FCC CFR Title 47 Part 15</b>						
B	6 dB Bandwidth	FCC 97-114	§15.247(2)	14Jul05	14Jul05	Pass
C	Peak Conducted Output Power	FCC 97-114	§15.247 (b) (3)	14Jul05	14Jul05	Pass
D	Maximum Permissible Exposure	FCC CFR 47 § 2.1091 IEEE Std C95.1-1992	§1.1310 Table 1 (b)	15Jul05	15Jul05	Pass
E	Radiated Spurious Emissions	FCC 97-114	§15.247(c)	4Jul05	13Jul05	Pass
F	Restricted Band Emissions	FCC 97-114	§15.205 (a), (b) §15.209 (a)	4Jul05	13Jul05	Pass
G	Peak Power Spectral Density	FCC 97-114	§15.247(d)	20Jul05	20Jul05	Pass
H	Powerline Conducted Emissions	ANSI C63.4	§15.207	20Jul05	20Jul05	Pass
<b>Referenced Standard: IC RSS-210 Issue 5</b>						
B	6 dB Bandwidth	RSS-210 § 10	RSS-210 A1 §(l)(iv)	14Jul05	14Jul05	Pass
C	Peak Conducted Output Power	RSS-210 § 10	RSS-210 A1 §(l)(iv) RSS-210 §6.2.2 (o)(b)	14Jul05	14Jul05	Pass
D	Maximum Permissible Exposure	RSS-102	RSS-210 §14 Safety Code 6 2.2.1(a) Table 5	15Jul05	15Jul05	Pass
E	Radiated Spurious Emissions	RSS-212, ANSI C63.4	RSS-210 §6.2.2 (o)(e1)	4Jul05	13Jul05	Pass
F	Restricted Band Emissions	RSS-212, ANSI C63.4	RSS-210 §6.3	4Jul05	13Jul05	Pass
G	Peak Power Spectral Density	RSS-210 § 10	RSS-210 §6.2.2 (o)(b)	20Jul05	20Jul05	Pass
H	Powerline Conducted Emissions	RSS-212, ANSI C63.4	RSS-210 §6.6	20Jul05	20Jul05	Pass

### REVISION LOG

Revision	Description	Implemented By	Implementation Date
0	Initial Release	Jonathan Hughes	8Dec05

### SIGNATORIES

Prepared By		December 08, 2005
Name/Title	Duane M. Friesen, C.E.T. / EMC Manager	Date
Reviewed By		December 08, 2005
Name/Title	Jonathan Hughes / General Manager	Date

<b>Applicant:</b>	Itronix Corporation	<b>Model:</b>	IX325A775IWLBT	<b>FCC ID:</b>	KBCIX325A775IWLBT	<b>IC ID:</b>	1943A-IX325e
<b>IX325 Rugged Tablet PC with internal Intel PRO2200BG 802.11b/g WLAN &amp; Well Green Dual Internal Antenna</b>							
2005 Celltech Labs Inc.	This document is not to be reproduced in whole or in part without the prior written permission of Celltech Labs Inc.						Page 4 of 59

	<b>Test Report Serial No.:</b>	060605KBC-T646-E15W	<b>Report Revision No.:</b>	Rev. 0
	<b>Test Date(s):</b>	4Jul05 - 20Jul05	<b>Report Issue Date:</b>	8Dec05
	<b>Test Standard(s):</b>	FCC 47 CFR §15.247	Industry Canada RSS-210 Issue 5	
	<b>Lab Registration(s):</b>	FCC Lab Reg. # 714830	Industry Canada Lab File #3874	

## 1.0 SCOPE

This report outlines the measurements made and results collected during the electromagnetic emissions testing of the Itronix Corporation Model: IX325A775IWLBT Rugged Tablet PC with internal Intel PRO2200BG 802.11b/g DSSS WLAN Mini-PCI Card and dual internal Well Green Technology PIFA WLAN antennas. The results were applied against the EMC requirements and limits outlined in the technical rules and regulations set forth in the Federal Communication Commission Code of Federal Regulations Title 47 Part 15 Subpart C and Industry Canada RSS-210 Issue 5.

## 2.0 REFERENCES

### 2.1 Normative References

ANSI/ISO 17025:1999	General Requirements for competence of testing and calibration laboratories
IEEE/ANSI C63.4-2003	Methods of Measurement of Radio-Noise Emissions from Low-Voltage Electrical and Electronic Equipment in the Range of 9 kHz to 40 GHz
IEEE/ANSI Std C95.1-1999	American National Standard Safety Levels with Respect to Human Exposure to Radio Frequency Electromagnetic Fields
CFR Title 47 Part 2:2004	Code of Federal Regulations Title 47: Telecommunication Part 2: Frequency Allocations and Radio Treaty Matters; General Rules and Regulations
CFR Title 47 Part 15:2004	Code of Federal Regulations Title 47: Telecommunication Part 15: Radio Frequency Devices
FCC Public Notice DA 00-705	Filing and Measurement Guidelines for Frequency Hopping Spread Spectrum Systems March 30, 2000
FCC Knowledge Database Pub.	558074 (May 10, 2005)
IC Spectrum Management & Telecommunications Policy	Radio Standards Specification RSS-212 Issue 1 (Provisional) - Test Facilities & Test Methods for Radio Equipment RSS-210 Issue 5 - Low Power Licence-Exempt Radiocommunication Devices: Amendment November 30, 2002 RSS-102 Issue 1 (Provisional) - Evaluation Procedure for Mobile and Portable Radio Transmitters with respect to Health Canada's Safety Code 6 for Exposure of Humans to Radio Frequency Fields

<b>Applicant:</b>	Itronix Corporation	<b>Model:</b>	IX325A775IWLBT	<b>FCC ID:</b>	KBCIX325A775IWLBT	<b>IC ID:</b>	1943A-IX325e
<b>IX325 Rugged Tablet PC with internal Intel PRO2200BG 802.11b/g WLAN &amp; Well Green Dual Internal Antenna</b>							
2005 Celltech Labs Inc.	This document is not to be reproduced in whole or in part without the prior written permission of Celltech Labs Inc.						Page 5 of 59

	<b>Test Report Serial No.:</b>	060605KBC-T646-E15W	<b>Report Revision No.:</b>	Rev. 0
	<b>Test Date(s):</b>	4Jul05 - 20Jul05	<b>Report Issue Date:</b>	8Dec05
	<b>Test Standard(s):</b>	FCC 47 CFR §15.247	Industry Canada RSS-210 Issue 5	
	<b>Lab Registration(s):</b>	FCC Lab Reg. # 714830	Industry Canada Lab File #3874	

## **TERMS AND DEFINITIONS**

AVG	Average
CFR	Code of Federal Regulations
dB	decibel
dBm	dB referenced to 1 mW
dBuV	dB referenced to 1 uV
DUT	Device under Test
dBc	dB down from carrier
EBW	Emission Bandwidth
EMC	Electromagnetic Compatibility
FCC	Federal Communication Commission
HP	Hewlett Packard
HPF	High Pass Filter
Hpol	Horizontal Polarization
IC	Industry Canada
kHz	kilohertz
LNA	Low Noise Amplifier
m	meter
MHz	Megahertz
Mbps	megabits per second
na	not applicable
n/a	not available
PK	Peak
PPSD	Peak Power Spectral Density
QP	Quasi-peak
RBW	Resolution Bandwidth
R&S	Rohde & Schwarz
RSS	Radio Standard Specification
SA	Spectrum Analyzer
VBW	Video Bandwidth
Vpol	Vertical Polarization
WLAN	Wireless Local Area Network

<b>Applicant:</b>	Itronix Corporation	<b>Model:</b>	IX325A775IWLBT	<b>FCC ID:</b>	KBCIX325A775IWLBT	<b>IC ID:</b>	1943A-IX325e
<b>IX325 Rugged Tablet PC with internal Intel PRO2200BG 802.11b/g WLAN &amp; Well Green Dual Internal Antenna</b>							
2005 Celltech Labs Inc.	This document is not to be reproduced in whole or in part without the prior written permission of Celltech Labs Inc.						Page 6 of 59

	<b>Test Report Serial No.:</b>	060605KBC-T646-E15W	<b>Report Revision No.:</b>	Rev. 0
	<b>Test Date(s):</b>	4Jul05 - 20Jul05	<b>Report Issue Date:</b>	8Dec05
	<b>Test Standard(s):</b>	FCC 47 CFR §15.247	Industry Canada RSS-210 Issue 5	
	<b>Lab Registration(s):</b>	FCC Lab Reg. # 714830	Industry Canada Lab File #3874	

### 3.0 FACILITIES AND ACCREDITATIONS

The facilities used in collecting the test results outlined in this report are located at 1955 Moss Court, Kelowna, British Columbia, Canada, V1Y 9L3. The radiated and conducted emissions sites conform with the requirements set forth in ANSI C63.4 and are filed and are listed with the FCC under Registration Number 714830 and Industry Canada under File Number IC 3874.

### 4.0 GENERAL INFORMATION

#### 4.1 Applicant Information

<b>Company Name:</b>	<b>Itronix Corporation</b>
<b>Address:</b>	801 South Stevens Street Spokane, WA 99204 United States

#### 4.2 DUT Description

The DUT consisted of the Itronix Rugged Tablet PC Model: IX325A775IWLBT with internal Intel PRO2200BG 802.11b/g DSSS WLAN Mini-PCI Card installed in the Mini-PCI slot, and internal PIFA antenna installed in the upper right side edge of the LCD display. Photographs of the DUT placement and construction are shown in Appendix A.

<b>Device:</b>	Rugged Tablet PC		
<b>Model:</b>	IX325A775IWLBT		
<b>Serial Number:</b>	ZZGEG5074ZZ9799		
<b>Identifier(s):</b>	<b>FCC ID:</b>	KBCIX325A775IWLBT	<b>IC:</b> 1943A-IX325e
<b>Power Source(s):</b>	Delta Electronics 75 Watt AC-DC Power Supply Model: ADP-75 FB B Rev 00 (S/N: UCT030200307)		
	Internal Lithium-ion 11.1 V 3600 mAh Battery Model: T8M-E		
	External Second Lithium-ion 11.1 V 3600 mAh Battery Model: T8S-E		

<b>Device:</b>	2.4GHz DSSS WLAN Mini-PCI Card (802.11b/g)		
<b>Model:</b>	Intel PRO2200BG		
<b>Serial Number:</b>	06036C074ADC54906006		
<b>Rule Part(s):</b>	<b>FCC:</b>	§15.247; §2.1091; §1.1310	<b>IC:</b> RSS-210 Issue 5 - A1. 11/30/02
<b>Classification:</b>	<b>FCC:</b>	Digital Transmission System (DTS)	<b>IC:</b> Low Power Licence-Exempt Transmitter
<b>Power Source:</b>	Powered from the internal PC power supply		

<b>Device:</b>	Internal PIFA WLAN Antenna 2 (diversity antenna for Transmit and Receive) - upper right side of LCD		
<b>Model:</b>	Well Green Technology WLAN Antenna		
<b>Gain:</b>	1.65 dBi		

<b>Applicant:</b>	Itronix Corporation	<b>Model:</b>	IX325A775IWLBT	<b>FCC ID:</b>	KBCIX325A775IWLBT	<b>IC ID:</b>	1943A-IX325e
IX325 Rugged Tablet PC with internal Intel PRO2200BG 802.11b/g WLAN & Well Green Dual Internal Antenna							
2005 Celltech Labs Inc.	This document is not to be reproduced in whole or in part without the prior written permission of Celltech Labs Inc.						Page 7 of 59



	<b>Test Report Serial No.:</b>	060605KBC-T646-E15W	<b>Report Revision No.:</b>	Rev. 0
	<b>Test Date(s):</b>	4Jul05 - 20Jul05	<b>Report Issue Date:</b>	8Dec05
	<b>Test Standard(s):</b>	FCC 47 CFR §15.247	Industry Canada RSS-210 Issue 5	
	<b>Lab Registration(s):</b>	FCC Lab Reg. # 714830	Industry Canada Lab File #3874	

<b>Device:</b>	Internal PIFA WLAN Antenna 1 (diversity antenna for Receive only) - upper left side of LCD
<b>Model:</b>	Well Green Technology WLAN Antenna
<b>Gain:</b>	2.41 dBi

#### 4.3 Co-Located Equipment

<b>Device:</b>	GPS Receiver Module
<b>Model:</b>	Leadtek Model LR9805

<b>Device:</b>	GPS Antenna (Receive only)
<b>Model:</b>	Sarantel 101401040/2004UK

#### 4.4 Cable Descriptions

ROUTING		Length m	Model	Terminations		Shield Type	Shield Termination		Suppression
From	To			End 1	End 2		End 1	End 2	
PC modem port	Unterminated	1.0	n/a	RJ-11	RJ-11	None	na	na	None

#### 4.5 Support Equipment

The following equipment was used in support of the DUT.

CO-LOCATED SUPPORT EQUIPMENT LIST		
MANUFACTURER	MODEL	DESCRIPTION
D-Link	DE-809TC/	Ethernet hub
YNG YUH	YP-040	Hub power supply
MLi	699	Speakers
Polk Audio	n/a	Speaker-microphone
	K8255	Keyboard
Sanwa Supply	MA-MBUSB	Mouse

<b>Applicant:</b>	Itronix Corporation	<b>Model:</b>	IX325A775IWLBT	<b>FCC ID:</b>	KBCIX325A775IWLBT	<b>IC ID:</b>	1943A-IX325e
IX325 Rugged Tablet PC with internal Intel PRO2200BG 802.11b/g WLAN & Well Green Dual Internal Antenna							
2005 Celltech Labs Inc.	This document is not to be reproduced in whole or in part without the prior written permission of Celltech Labs Inc.						Page 8 of 59



	<b>Test Report Serial No.:</b>	060605KBC-T646-E15W	<b>Report Revision No.:</b>	Rev. 0
	<b>Test Date(s):</b>	4Jul05 - 20Jul05	<b>Report Issue Date:</b>	8Dec05
	<b>Test Standard(s):</b>	FCC 47 CFR §15.247	Industry Canada RSS-210 Issue 5	
	<b>Lab Registration(s):</b>	FCC Lab Reg. # 714830	Industry Canada Lab File #3874	

#### 4.6 Clock Frequencies

##### 4.6.1 DUT Clock Frequencies

<b>Device:</b>	Rugged Tablet PC
<b>Clocks:</b>	n/a
<b>Name:</b>	2.4GHz DSSS WLAN Mini-PCI Card
<b>Clocks:</b>	n/a
<b>Name:</b>	Internal PIFA Antenna (WLAN)
<b>Clocks:</b>	None

##### 4.6.2 Co-Located Clock Frequencies

<b>Device:</b>	Peripherals
<b>Clocks:</b>	n/a

#### 4.7 Mode(s) of Operation Tested

Customer supplied the software which was used to set the WLAN card in the appropriate mode, channel, and power level for the specific measurement.

<b>TX Frequency Range:</b>	2412 - 2462 MHz Ch. 1 (2412 MHz), Ch. 6 (2437 MHz) & Ch. 11 (2462 MHz) measured unless otherwise noted					
<b>Software Power Gain Settings:</b>	802.11b set to power setting of 27 802.11g set to power setting of 20					
<b>RF Peak Conducted Output Power Tested:<sup>1</sup></b>	<b>802.11b</b>	1 Mbps	11 Mbps	<b>802.11g</b>	6 Mbps	54 Mbps
	2412 MHz	18.20 dBm	19.63 dBm	2412 MHz	16.24 dBm	15.96 dBm
	2437 MHz	18.56 dBm	20.49 dBm	2437 MHz	16.67 dBm	16.30 dBm
	2462 MHz	19.04 dBm	20.41 dBm	2462 MHz	16.77 dBm	16.54 dBm
<b>Modes / Data Rates Tested:<sup>2</sup></b>	802.11b (1, 5.5, 11 Mbps checked in prescan) (1 Mbps short determined to be worst-case spurious and used unless otherwise noted)					
	802.11g (6, 36, 54 Mbps checked in prescan) (6 Mbps determined to be worst-case spurious and used unless otherwise noted)					
<b>Modulation Type(s):</b>	OFDM with BPSK, QPSK, 16QAM, 64QAM, DBPSK, DQPSK, CCK					
<b>Power Source(s) Tested:</b>	All tests were performed with the AC Power Adapter powering the DUT.					

Note 1: Peak power measured and corrected per FCC Document KDB Pub. No. 558074 Power Output Option 2 Method 1

Note 2: Turbo mode available at module level but not enabled when installed in DUT

<b>Applicant:</b>	Itronix Corporation	<b>Model:</b>	IX325A775IWLBT	<b>FCC ID:</b>	KBCIX325A775IWLBT	<b>IC ID:</b>	1943A-IX325e
<b>IX325 Rugged Tablet PC with internal Intel PRO2200BG 802.11b/g WLAN &amp; Well Green Dual Internal Antenna</b>							
2005 Celltech Labs Inc.	This document is not to be reproduced in whole or in part without the prior written permission of Celltech Labs Inc.						Page 9 of 59

	<b>Test Report Serial No.:</b>	060605KBC-T646-E15W	<b>Report Revision No.:</b>	Rev. 0
	<b>Test Date(s):</b>	4Jul05 - 20Jul05	<b>Report Issue Date:</b>	8Dec05
	<b>Test Standard(s):</b>	FCC 47 CFR §15.247	Industry Canada RSS-210 Issue 5	
	<b>Lab Registration(s):</b>	FCC Lab Reg. # 714830	Industry Canada Lab File #3874	

#### 4.7.1 DUT Exercising Software Description

The DUT was configured and exercised using customer supplied test software that allows an operator to set the parameters of the WLAN operation. The settings used are described in each appendix. Unless otherwise noted the power gain settings were set as described in section 5.6 with the worst-case data rate as described in the same section. Software power settings were set as defined by the manufacturer for typical operation.

#### 4.8 Configuration Description

The DUT was configured, as described by the client as being representative of what would be delivered to a final customer. This configuration included the WLAN and internal antenna as described in section 5.2 installed in a typical manner. More specific details may be included in each appendix.

##### 4.8.1 Configuration Justification

The DUT was tested in a configuration described by the client as being worst-case but typical of normal use.

Prescan measurements were made with the WLAN in each of the two available modes (b & g), lowest and highest bit rates and each of the lowest, highest and mid-band frequencies. From this preliminary data, it was determined that Mode b Rate 1 Mbps resulted in the highest spurious emissions. When a measurement of Mode g was required, its data rate was set for a worst-case setting of 6 Mbps. Unless otherwise specified in the applicable appendices, these settings were used for the measurements described in this report.

### 5.0 PASS/FAIL CRITERIA

Unless otherwise noted in the Appendices, the pass/fail criteria is the limit set forth in the reference standards. A DUT is considered to have passed the requirements, if the data collected during the described measurement procedure is less than or equal to the specified limits as defined. The pass/fail statements made in this report only apply to the unit tested.

<b>Applicant:</b>	Itronix Corporation	<b>Model:</b>	IX325A775IWLBT	<b>FCC ID:</b>	KBCIX325A775IWLBT	<b>IC ID:</b>	1943A-IX325e
<b>IX325 Rugged Tablet PC with internal Intel PRO2200BG 802.11b/g WLAN &amp; Well Green Dual Internal Antenna</b>							
2005 Celltech Labs Inc.	This document is not to be reproduced in whole or in part without the prior written permission of Celltech Labs Inc.						Page 10 of 59

	<b>Test Report Serial No.:</b>	060605KBC-T646-E15W	<b>Report Revision No.:</b>	Rev. 0
	<b>Test Date(s):</b>	4Jul05 - 20Jul05	<b>Report Issue Date:</b>	8Dec05
	<b>Test Standard(s):</b>	FCC 47 CFR §15.247	Industry Canada RSS-210 Issue 5	
	<b>Lab Registration(s):</b>	FCC Lab Reg. # 714830	Industry Canada Lab File #3874	

## APPENDICES

<b>Applicant:</b>	Itronix Corporation	<b>Model:</b>	IX325A775IWLBT	<b>FCC ID:</b>	KBCIX325A775IWLBT	<b>IC ID:</b>	1943A-IX325e
<b>IX325 Rugged Tablet PC with internal Intel PRO2200BG 802.11b/g WLAN &amp; Well Green Dual Internal Antenna</b>							
2005 Celltech Labs Inc.	This document is not to be reproduced in whole or in part without the prior written permission of Celltech Labs Inc.						Page 11 of 59

<b>Test Report Serial No.:</b>	060605KBC-T646-E15W	<b>Report Revision No.:</b>	Rev. 0
<b>Test Date(s):</b>	4Jul05 - 20Jul05	<b>Report Issue Date:</b>	8Dec05
<b>Test Standard(s):</b>	FCC 47 CFR §15.247	Industry Canada RSS-210 Issue 5	
<b>Lab Registration(s):</b>	FCC Lab Reg. # 714830	Industry Canada Lab File #3874	

### Appendix A - DUT Photographs

Photograph A-1 - Front of IX325 Tablet PC



Photograph A-2 - Back of IX325 Tablet PC



Photograph A-3 - Edge of IX325 Tablet PC



Photograph A-4 - Side of IX325 Tablet PC



Photograph A-5 - WLAN Mini-PCI Card Location



Photograph A-6 - WLAN Dual Antenna Location

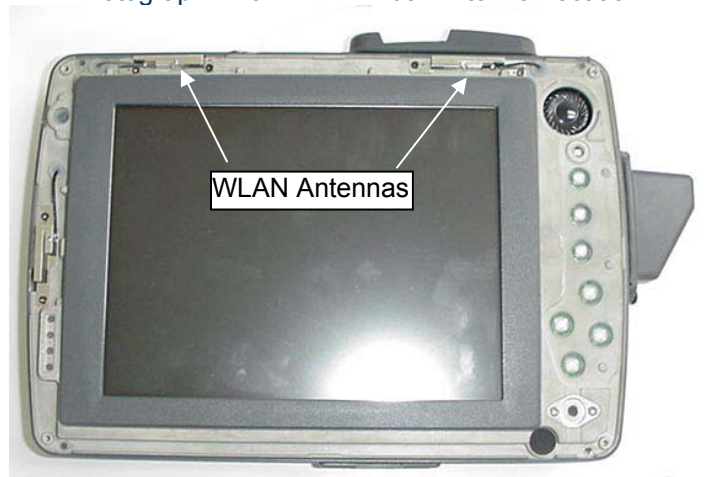

<b>Applicant:</b>	Itronix Corporation	<b>Model:</b>	IX325A775IWLBT	<b>FCC ID:</b>	KBCIX325A775IWLBT	<b>IC ID:</b>	1943A-IX325e
<b>IX325 Rugged Tablet PC with internal Intel PRO2200BG 802.11b/g WLAN &amp; Well Green Dual Internal Antenna</b>							
2005 Celltech Labs Inc.	This document is not to be reproduced in whole or in part without the prior written permission of Celltech Labs Inc.						Page 12 of 59

	<b>Test Report Serial No.:</b>	060605KBC-T646-E15W	<b>Report Revision No.:</b>	Rev. 0
	<b>Test Date(s):</b>	4Jul05 - 20Jul05	<b>Report Issue Date:</b>	8Dec05
	<b>Test Standard(s):</b>	FCC 47 CFR §15.247	Industry Canada RSS-210 Issue 5	
	<b>Lab Registration(s):</b>	FCC Lab Reg. # 714830	Industry Canada Lab File #3874	

## Appendix B - 6 dB Bandwidth Measurement

B.1. REFERENCES	
<b>Normative Reference Standard</b>	FCC CFR 47 §15.247 (2)
<b>Procedure Reference</b>	FCC Document KDB Publication Number 558074

B.2. LIMITS	
B.2.1. FCC CFR 47	
FCC CFR 47 §15.247	<i>(2) Systems using digital modulation techniques may operate in the 902-928 MHz, 2400-2483.5 MHz, and 5725-5850 MHz bands. The minimum 6 dB bandwidth shall be at least 500 kHz</i>

B.3. ENVIRONMENTAL CONDITIONS	
<b>Temperature</b>	25 +/- 2 °C
<b>Humidity</b>	35 +/- 2 %
<b>Barometric Pressure</b>	96 kPa

B.4. EQUIPMENT LIST					
ASSET NUMBER	MANUFACTURER	MODEL	DESCRIPTION	LAST CAL	CAL DUE
00015	Agilent	E4408B	Spectrum Analyzer	24Jan05	24Jan06
00075	Alpha Wire-J	9223	1ft. RG223/U RF Cable	na*	na
00076	Pasternack	PE7014-30	30dB 2 Watt Attenuator	na*	na

\*Cable and attenuator verified with power meter prior to use

<b>Applicant:</b>	Itronix Corporation	<b>Model:</b>	IX325A775IWLBT	<b>FCC ID:</b>	KBCIX325A775IWLBT	<b>IC ID:</b>	1943A-IX325e
IX325 Rugged Tablet PC with internal Intel PRO2200BG 802.11b/g WLAN & Well Green Dual Internal Antenna							
2005 Celltech Labs Inc.	This document is not to be reproduced in whole or in part without the prior written permission of Celltech Labs Inc.						Page 13 of 59

	<b>Test Report Serial No.:</b>	060605KBC-T646-E15W	<b>Report Revision No.:</b>	Rev. 0
	<b>Test Date(s):</b>	4Jul05 - 20Jul05	<b>Report Issue Date:</b>	8Dec05
	<b>Test Standard(s):</b>	FCC 47 CFR §15.247	Industry Canada RSS-210 Issue 5	
	<b>Lab Registration(s):</b>	FCC Lab Reg. # 714830	Industry Canada Lab File #3874	

**B.5. MEASUREMENT EQUIPMENT SETUP**

<b>Measurement Equipment Connections</b>	The equipment was connected as shown in the setup drawing in B.6.
<b>Measurement Equipment Settings</b>	To evaluate the occupied bandwidth, software and a PC controller were used to set the spectrum analyzer using the following setting: RBW – 100 kHz VBW – 100kHz Span – 50 MHz Detector – Sample Average – Power Average Count – 100 Offset – appropriate for external attenuation (-31.4 dB)

**B.6. SETUP DRAWING**

Figure B.6-1 - Setup Drawing

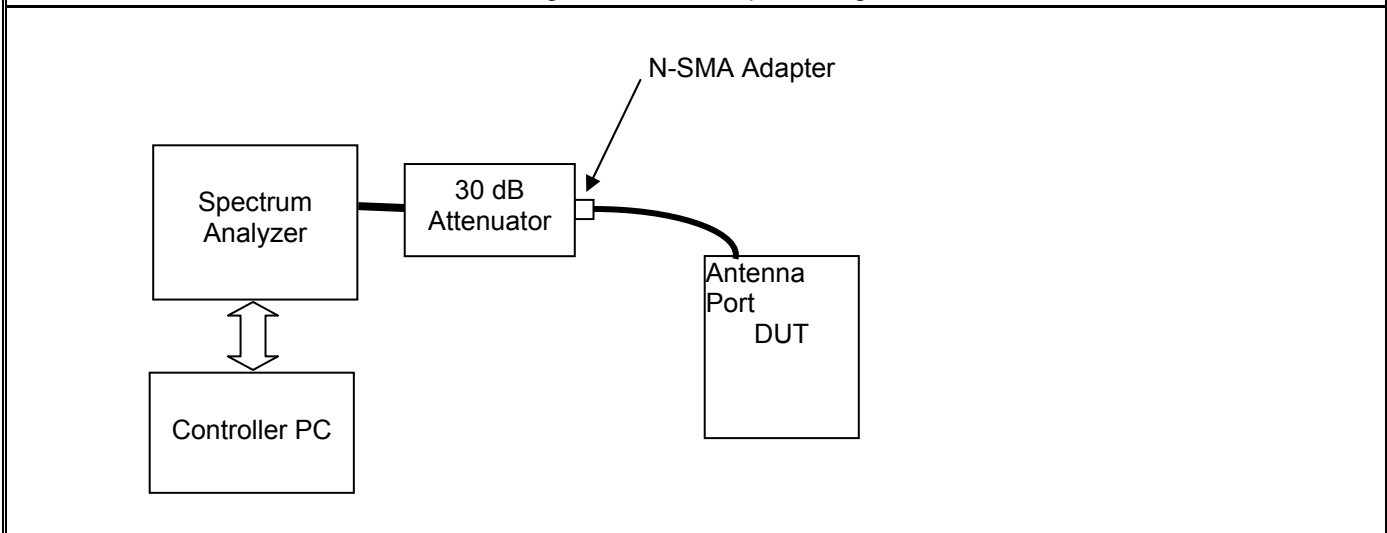

**B.7. DUT OPERATING DESCRIPTION**

The worst-case data rate was determined from prescan investigations. Measurements were made at three channels throughout the band, Low Channel (2412 MHz), Mid Channel (2437 MHz), High Channel (2462 MHz) for both Modes b and g.

<b>Applicant:</b>	Itronix Corporation	<b>Model:</b>	IX325A775IWLBT	<b>FCC ID:</b>	KBCIX325A775IWLBT	<b>IC ID:</b>	1943A-IX325e
<b>IX325 Rugged Tablet PC with internal Intel PRO2200BG 802.11b/g WLAN &amp; Well Green Dual Internal Antenna</b>							
2005 Celltech Labs Inc.	This document is not to be reproduced in whole or in part without the prior written permission of Celltech Labs Inc.						Page 14 of 59

<b>Test Report Serial No.:</b>	060605KBC-T646-E15W	<b>Report Revision No.:</b>	Rev. 0
<b>Test Date(s):</b>	4Jul05 - 20Jul05	<b>Report Issue Date:</b>	8Dec05
<b>Test Standard(s):</b>	FCC 47 CFR §15.247	Industry Canada RSS-210 Issue 5	
<b>Lab Registration(s):</b>	FCC Lab Reg. # 714830	Industry Canada Lab File #3874	

## B.8. TEST RESULTS

### B.8.1. Mode b Occupied Bandwidth

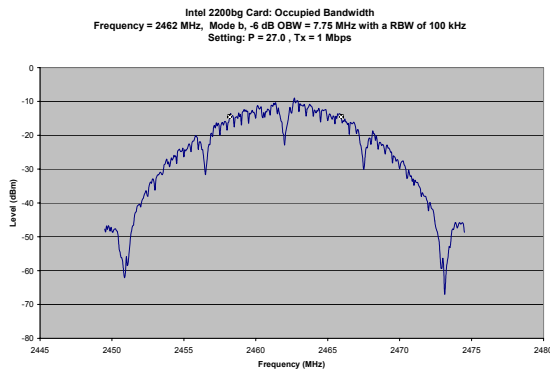
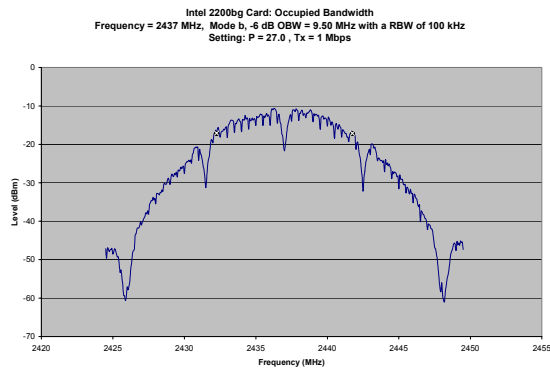
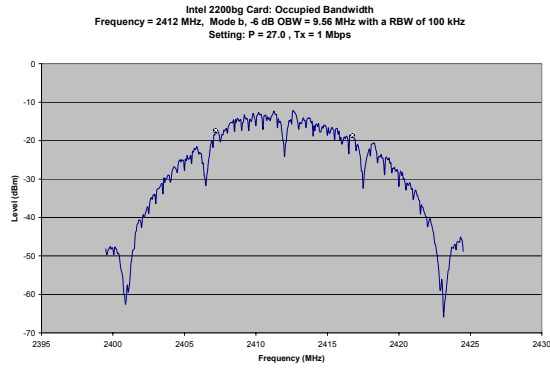

Channel	Channel Frequency (MHz)	6 dB Bandwidth (MHz)	Minimum Limit (MHz)	Pass/Fail
1	2412	9.56	0.5	PASS
6	2437	9.50	0.5	PASS
11	2462	7.75	0.5	PASS



<b>Test Report Serial No.:</b>	060605KBC-T646-E15W	<b>Report Revision No.:</b>	Rev. 0
<b>Test Date(s):</b>	4Jul05 - 20Jul05	<b>Report Issue Date:</b>	8Dec05
<b>Test Standard(s):</b>	FCC 47 CFR §15.247	Industry Canada RSS-210 Issue 5	
<b>Lab Registration(s):</b>	FCC Lab Reg. # 714830	Industry Canada Lab File #3874	

### B.8.2. Mode g Occupied Bandwidth

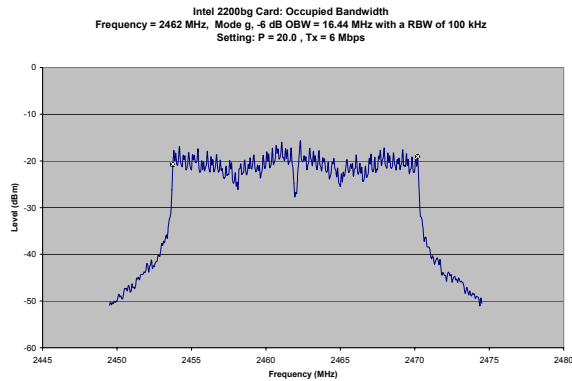
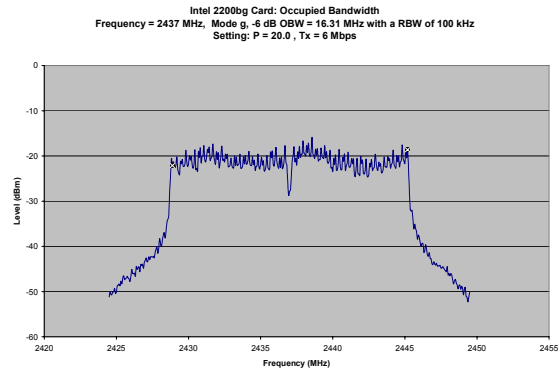
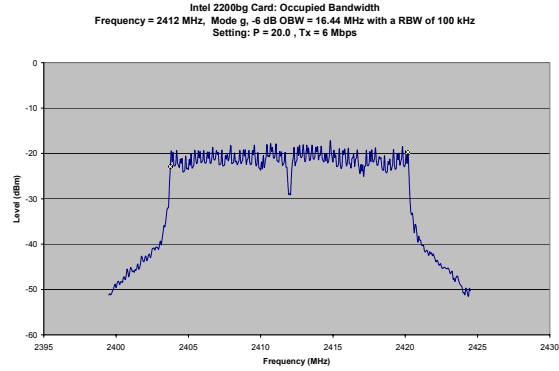

Channel	Channel Frequency (MHz)	6 dB Bandwidth (MHz)	Minimum Limit (MHz)	Pass/Fail
1	2412	16.44	0.5	PASS
6	2437	16.31	0.5	PASS
11	2462	16.44	0.5	PASS

	<b>Test Report Serial No.:</b>	060605KBC-T646-E15W	<b>Report Revision No.:</b>	Rev. 0
	<b>Test Date(s):</b>	4Jul05 - 20Jul05	<b>Report Issue Date:</b>	8Dec05
	<b>Test Standard(s):</b>	FCC 47 CFR §15.247	Industry Canada RSS-210 Issue 5	
	<b>Lab Registration(s):</b>	FCC Lab Reg. # 714830	Industry Canada Lab File #3874	

### B.9. PASS/FAIL

In reference to the results outlined in B.8, the DUT passes the requirements as stated in the reference standards as follows:

FCC 15.247 (2): The 6 dB bandwidth as measured meets the minimum 500 kHz bandwidth requirement.

The minimum 6 dB bandwidth measured for Mode b was 7.75 MHz and for Mode g was 16.31 MHz.

### B.10. SIGN-OFF

I attest to the accuracy of the data. All measurements reported herein were performed by me and are correct to the best of my knowledge and belief. I assume full responsibility for the completeness of these measurements.

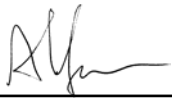

\_\_\_\_\_  
 Alex Yuan  
 EMC Technologist  
 Celltech Labs Inc.

\_\_\_\_\_  
 14Jul05

Date

<b>Applicant:</b>	Itronix Corporation	<b>Model:</b>	IX325A775IWLBT	<b>FCC ID:</b>	KBCIX325A775IWLBT	<b>IC ID:</b>	1943A-IX325e
<b>IX325 Rugged Tablet PC with internal Intel PRO2200BG 802.11b/g WLAN &amp; Well Green Dual Internal Antenna</b>							
2005 Celltech Labs Inc.	This document is not to be reproduced in whole or in part without the prior written permission of Celltech Labs Inc.						Page 17 of 59

	<b>Test Report Serial No.:</b>	060605KBC-T646-E15W	<b>Report Revision No.:</b>	Rev. 0
	<b>Test Date(s):</b>	4Jul05 - 20Jul05	<b>Report Issue Date:</b>	8Dec05
	<b>Test Standard(s):</b>	FCC 47 CFR §15.247	Industry Canada RSS-210 Issue 5	
	<b>Lab Registration(s):</b>	FCC Lab Reg. # 714830	Industry Canada Lab File #3874	

### Appendix C - Peak Conducted RMS Power Measurement

<b>C.1. REFERENCES</b>	
<b>Normative Reference Standard</b>	FCC CFR 47 §15.247(b) (3)
<b>Procedure Reference</b>	FCC Document KDB Publication Number 558074

<b>C.2. LIMITS</b>	
C.2.1. FCC CFR	
<p>§15.247(b): The maximum peak output power of the intentional radiator shall not exceed the following:  §15.247(b) (3) For system using digital modulation in the 902 – 928 MHz, 2400 – 2483.5 MHz, and 5725 – 5850 MHz bands: 1 Watt.</p>	

<b>C.3. ENVIRONMENTAL CONDITIONS</b>	
<b>Temperature</b>	25 +/- 2 °C
<b>Humidity</b>	35 +/- 2 %
<b>Barometric Pressure</b>	96 kPa

<b>C.4. EQUIPMENT LIST</b>					
ASSET NUMBER	MANUFACTURER	MODEL	DESCRIPTION	LAST CAL	CAL DUE
00015	Agilent	E4408B	Spectrum Analyzer	24Jan05	24Jan06
00075	Alpha Wire-J	9223	1ft. RG223/U RF Cable	na*	na
00076	Pasternack	PE7014-30	30dB 2 Watt Attenuator	na*	na

\*Cable and attenuator verified with power meter prior to use

<b>C.5. MEASUREMENT EQUIPMENT SETUP</b>	
<b>Measurement Equipment Connections</b>	The equipment was connected as shown in the setup drawing in C.6.
<b>Measurement Equipment Settings</b>	To evaluate the maximum peak power, with the following spectrum analyzer settings were used: RBW – 3 MHz VBW – 3 MHz Detector – Peak Trace – Max Hold Span -25 MHz
<b>Measurement Procedure</b>	A PC controller was used to record the spectrum analyzer display and pick the maximum level and to determine the emission bandwidth (EBW). It then corrected the peak level recorded with a bandwidth correction factor of $10 * \log (EBW/RBW)$ . The corrected peak value was recorded and reported herein.

<b>Applicant:</b>	Itronix Corporation	<b>Model:</b>	IX325A775IWLBT	<b>FCC ID:</b>	KBCIX325A775IWLBT	<b>IC ID:</b>	1943A-IX325e
IX325 Rugged Tablet PC with internal Intel PRO2200BG 802.11b/g WLAN & Well Green Dual Internal Antenna							
2005 Celltech Labs Inc.	This document is not to be reproduced in whole or in part without the prior written permission of Celltech Labs Inc.						Page 18 of 59

**C.6. SETUP DRAWING**

Figure C.6-1 - Setup Drawing

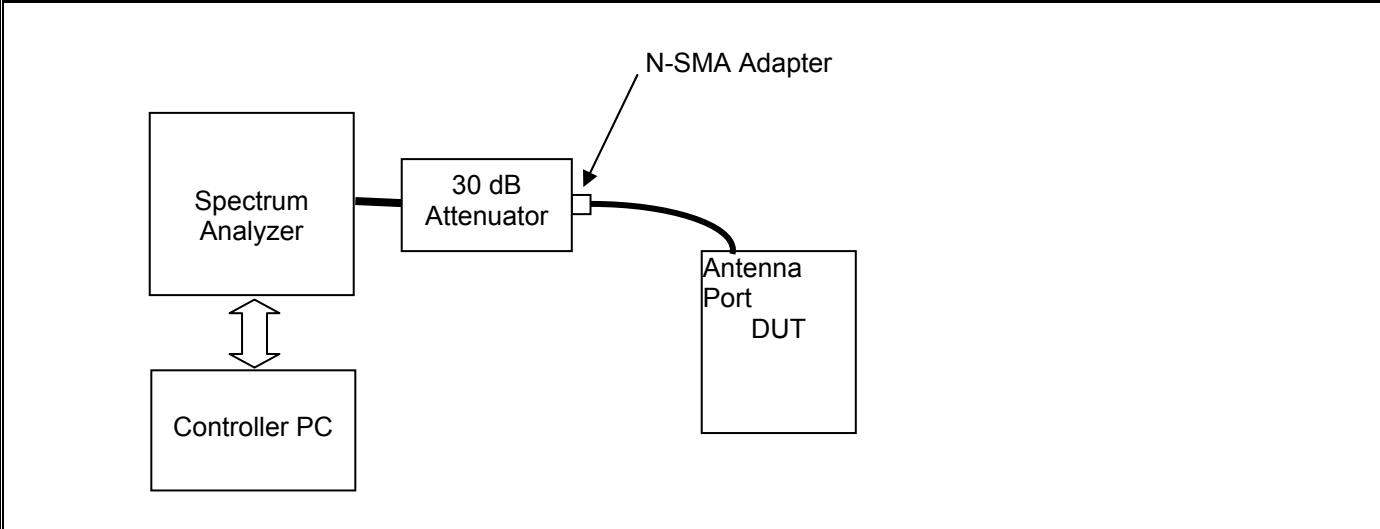

**C.7. DUT OPERATING DESCRIPTION**

The worst-case data rate was determined from prescan investigations. Measurements were made at three channels throughout the band, Low Channel (2412 MHz), Mid Channel (2437 MHz), High Channel (2462 MHz) for both Modes b and g. The measurements were made for both the lowest and highest data rate available for the mode.

**C.8. TEST RESULTS**

Channel	Frequency	802.11b					802.11g				
		Data Rate	Peak Conducted Power*		Limit	-26 dB EBW	Data Rate	Peak Conducted Power*		Limit	-26 dB EBW
	MHz	Mb/s	dBm	Watts	Watts	MHz	Mb/s	dBm	Watts	Watts	MHz
Low	2412	1	18.20	0.066	1	19.25	6	16.24	0.042	1	19.88
		11	19.63	0.092	1	19.25	54	15.96	0.039	1	19.75
Mid	2437	1	18.56	0.072	1	19.25	6	16.67	0.046	1	20.00
		11	20.49	0.112	1	19.38	54	16.30	0.043	1	19.88
High	2462	1	19.04	0.080	1	19.50	6	16.77	0.048	1	19.88
		11	20.41	0.110	1	19.50	54	16.54	0.045	1	19.88

\*Corrected Peak Power (corrected for BW),  
Peak Conducted Power (dBm) = Measured Conducted Power (dBm) + 10 \* log (EBW / 3 MHz)

	<b>Test Report Serial No.:</b>	060605KBC-T646-E15W	<b>Report Revision No.:</b>	Rev. 0
	<b>Test Date(s):</b>	4Jul05 - 20Jul05	<b>Report Issue Date:</b>	8Dec05
	<b>Test Standard(s):</b>	FCC 47 CFR §15.247	Industry Canada RSS-210 Issue 5	
	<b>Lab Registration(s):</b>	FCC Lab Reg. # 714830	Industry Canada Lab File #3874	

**C.9. PASS/FAIL**

In reference to the results outlined in C.8 the DUT passes the requirements as stated in the reference standards as follows:  
FCC 15.247 (b) (3): The peak power did not exceed 1 Watt.  
 The maximum peak power measured for Mode b was 0.112 watts, and for Mode g was 0.048 watts.

**C.10. SIGN-OFF**

I attest to the accuracy of the data. All measurements reported herein were performed by me and are correct to the best of my knowledge and belief. I assume full responsibility for the completeness of these measurements.



\_\_\_\_\_  
 Alex Yuan  
 EMC Technologist  
 Celltech Labs Inc.

\_\_\_\_\_  
 14Jul05  
 Date

<b>Applicant:</b>	Itronix Corporation	<b>Model:</b>	IX325A775IWLBT	<b>FCC ID:</b>	KBCIX325A775IWLBT	<b>IC ID:</b>	1943A-IX325e
<b>IX325 Rugged Tablet PC with internal Intel PRO2200BG 802.11b/g WLAN &amp; Well Green Dual Internal Antenna</b>							
2005 Celltech Labs Inc.	This document is not to be reproduced in whole or in part without the prior written permission of Celltech Labs Inc.						Page 20 of 59

 <b>Celltech</b> <small>Testing and Engineering Services Lab</small>	<b>Test Report Serial No.:</b>	060605KBC-T646-E15W	<b>Report Revision No.:</b>	Rev. 0
	<b>Test Date(s):</b>	4Jul05 - 20Jul05	<b>Report Issue Date:</b>	8Dec05
	<b>Test Standard(s):</b>	FCC 47 CFR §15.247	Industry Canada RSS-210 Issue 5	
	<b>Lab Registration(s):</b>	FCC Lab Reg. # 714830	Industry Canada Lab File #3874	

## Appendix D - Radiated Spurious Emissions Measurement

### D.1. REFERENCES

<b>Normative Reference Standard</b>	FCC CFR 47 §15.247(c)
<b>Procedure Reference</b>	ANSI C63.4; FCC 97-114

### D.2. LIMITS

#### D.2.1. FCC CFR 47

§15.247 (c): In any 100 kHz bandwidth outside the frequency band in which the spread spectrum or digitally modulated intentional radiator is operating, the radio frequency power that is produced by the intentional radiator shall be at least 20 dB below that in the 100 kHz bandwidth within the band that contains the highest level of desired power, based on either an RF conducted or a radiated measurement. Attenuation below the general limits specified in 15.209 (a) is not required.

Note: Spurious emissions within the restricted bands are reported in Appendix F.

### D.3. ENVIRONMENTAL CONDITIONS

<b>Temperature</b>	27 +/- 2 °C
<b>Humidity</b>	33 +/- 2 %
<b>Barometric Pressure</b>	96 +/- 0.2 kPa

### D.4. EQUIPMENT LIST

RECEIVING EQUIPMENT						
ID	ASSET NUMBER	MANUFACTURER	MODEL	DESCRIPTION	LAST CAL	CAL DUE
1	00072	EMCO	2075	Mini-mast	na	na
2	00073	EMCO	2080	Turn Table	na	na
3	00071	EMCO	2090	Multi-Device Controller	na	na
4	00035	ETS	3115	Double Ridged Guide Horn	24Mar04	24Mar06
5	00161/00166	Waveline	899/801-KF	Standard Gain Horn	na	na
6	00051	HP	8566B	Spectrum Analyzer RF Section	12Apr05	12Apr06
7	00049	HP	85650A	Quasi-Peak Adapter	13Apr05	13Apr06
8	00047	HP	85685A	RF Preselector	13Apr05	13Apr06
9	00015	Agilent	4408B	Spectrum Analyzer	24Jan05	24Jan06
10	00115	Miteq	J54-00102600-35-5A	LNA	08Jun04	08Jun06
11	00093	Microtronics	HPM50111	High Pass Filter	8Jun04	8Dec05
12	00119	INMAT	18AH-10	10dB attenuator	8Jun04	8Dec05
13	00120	Celltech	n/a	Microwave Cable (RX)	25Mar05	25Mar06
14	00121	Andrew	FSJ4-50B	Microwave Cable (RX)	25Mar05	25Mar06
15	00130	Andrew	FSJ1-50A	Microwave Cable (RX)	25Mar05	25Mar06

<b>Applicant:</b>	Itronix Corporation	<b>Model:</b>	IX325A775IWLBT	<b>FCC ID:</b>	KBCIX325A775IWLBT	<b>IC ID:</b>	1943A-IX325e
<b>IX325 Rugged Tablet PC with internal Intel PRO2200BG 802.11b/g WLAN &amp; Well Green Dual Internal Antenna</b>							
2005 Celltech Labs Inc.	This document is not to be reproduced in whole or in part without the prior written permission of Celltech Labs Inc.						Page 21 of 59

D.5. MEASUREMENT EQUIPMENT SETUP				
<b>MEASUREMENT EQUIPMENT CONNECTIONS</b>	The measurement equipment was connected as shown in the E.6. A number of antennas were used to cover the applicable frequency range test. The ranges in which each antenna was used are as follows:			
	Frequency Range	Spectrum Analyzer Asset #	LNA/Filter/Attenuator Asset #	Antenna Asset #
	2 GHz – 10 GHz	00051	00093/00115	00035
	10 GHz – 20 GHz	00015	00093/00115	00161/00166
	20 GHz – 26 GHz	00015	00093	00161/00166
<b>MEASUREMENT EQUIPMENT SETTINGS</b>	The spectrum analyzer was set to the following settings:			
	Frequency Range	RBW	VBW	Detector
	MHz	kHz	kHz	
	> 1000	1000*	1000	Peak*
	*As a worst-case measurement, the average/QP limit was applied to measurements made with a peak detector using a RBW of 1 MHz (vs the specified 100 kHz), unless otherwise noted. Average measurements were performed with video averaging using a VBW of 30 Hz.			

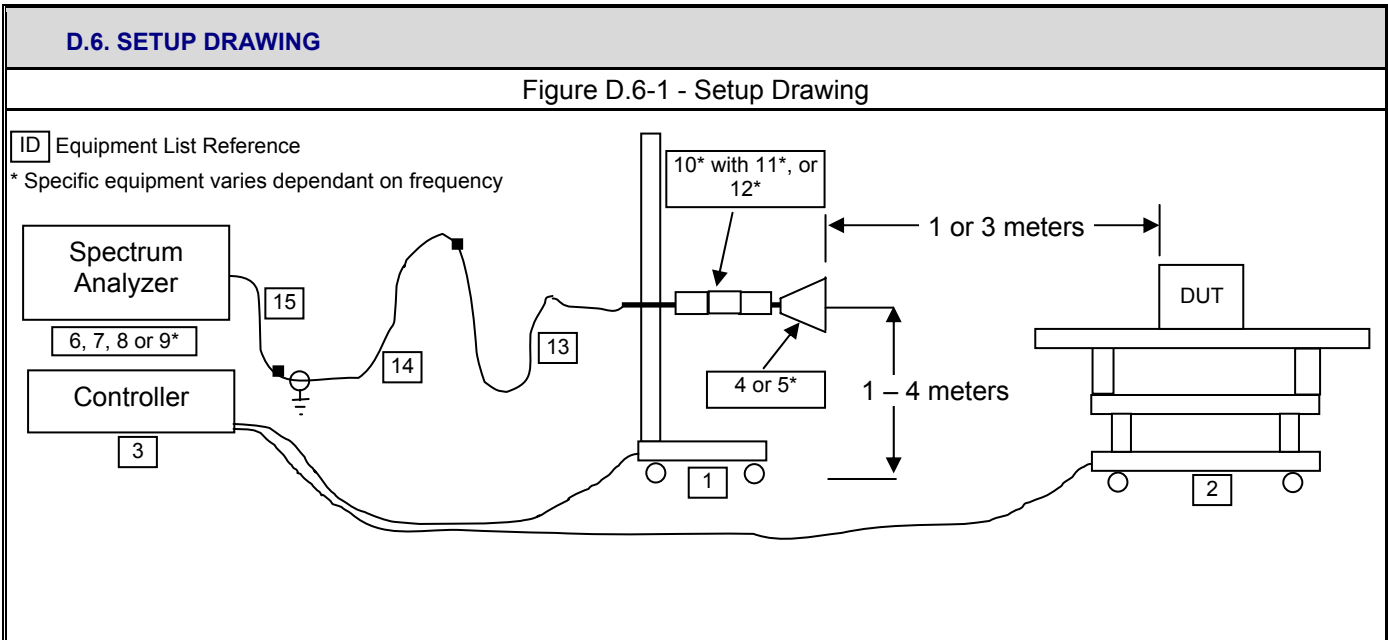



	<b>Test Report Serial No.:</b>	060605KBC-T646-E15W	<b>Report Revision No.:</b>	Rev. 0
	<b>Test Date(s):</b>	4Jul05 - 20Jul05	<b>Report Issue Date:</b>	8Dec05
	<b>Test Standard(s):</b>	FCC 47 CFR §15.247	Industry Canada RSS-210 Issue 5	
	<b>Lab Registration(s):</b>	FCC Lab Reg. # 714830	Industry Canada Lab File #3874	

**D.7. SETUP PHOTOGRAPHS**

Photograph D-1 - 3115 Horn @ 3 m



Photograph D-2 - 3115 Horn with LNA/Filter @ 1m



Photograph D-3 - Waveline Horn with LNA @ 1m



Intentionally Left Blank

**D.8. DUT OPERATING DESCRIPTION**

The worst-case data rate was determined from prescan investigations. Measurements were made at three channels throughout the band, Low Channel (2412 MHz), Mid Channel (2437 MHz), High Channel (2462 MHz) for both Modes b and g.

<b>Applicant:</b>	Itronix Corporation	<b>Model:</b>	IX325A775IWLBT	<b>FCC ID:</b>	KBCIX325A775IWLBT	<b>IC ID:</b>	1943A-IX325e
<b>IX325 Rugged Tablet PC with internal Intel PRO2200BG 802.11b/g WLAN &amp; Well Green Dual Internal Antenna</b>							
2005 Celltech Labs Inc.	This document is not to be reproduced in whole or in part without the prior written permission of Celltech Labs Inc.						Page 23 of 59

	<b>Test Report Serial No.:</b>	060605KBC-T646-E15W	<b>Report Revision No.:</b>	Rev. 0
	<b>Test Date(s):</b>	4Jul05 - 20Jul05	<b>Report Issue Date:</b>	8Dec05
	<b>Test Standard(s):</b>	FCC 47 CFR §15.247	Industry Canada RSS-210 Issue 5	
	<b>Lab Registration(s):</b>	FCC Lab Reg. # 714830	Industry Canada Lab File #3874	

## D.9. TEST RESULTS

### D.9.1. Mode b - Fundamental Field Strengths @ Specified Distance (100 kHz RBW)

	<b>Project Numb</b>	060605KBC-T643-E15W	<b>Standard:</b>	FCC15.247a
	<b>Company:</b>	Itronix	<b>Test Start Date:</b>	4-Jul-05
	<b>Product:</b>	IX325 with Intel PRO 2200BG	<b>Test End Date:</b>	13-Jul-05

#### IX325 with Intel WLAN Mode b with Setting 27, Tx = 1 Mbps Carrier Field Strengths

Channel	Polarity	Measurement Distance	Antenna	Frequency	SA Level	Noise Floor	AF	CL	Other	Total CF	Field Strength	Detector	RBW
							dB/m	dB	dB	dB/m	dBuV/m		
WLAN-CH1	H	3	Horn SN6276	2412.00	77.90		30.26	5.10	-23.13	12.23	90.13	PK	100
WLAN-CH1	H	3	Horn SN6276	2412.00	66.90		30.26	5.10	-23.13	12.23	79.13	AV	100
WLAN-CH1	V	3	Horn SN6276	2412.00	80.50		30.26	5.10	-23.13	12.23	92.73	PK	100
WLAN-CH1	V	3	Horn SN6276	2412.00	69.50		30.26	5.10	-23.13	12.23	81.73	AV	100
WLAN-CH6	H	3	Horn SN6276	2437.00	78.40		30.30	5.14	-23.12	12.31	90.71	PK	100
WLAN-CH6	H	3	Horn SN6276	2437.00	67.20		30.30	5.14	-23.12	12.31	79.51	AV	100
WLAN-CH6	V	3	Horn SN6276	2437.00	81.15		30.30	5.14	-23.12	12.31	93.46	PK	100
WLAN-CH6	V	3	Horn SN6276	2437.00	70.00		30.30	5.14	-23.12	12.31	82.31	AV	100
WLAN-CH11	H	3	Horn SN6276	2462.00	78.65		30.34	5.16	-23.12	12.38	91.03	PK	100
WLAN-CH11	H	3	Horn SN6276	2462.00	67.30		30.34	5.16	-23.12	12.38	79.68	AV	100
WLAN-CH11	V	3	Horn SN6276	2462.00	81.75		30.34	5.16	-23.12	12.38	94.13	PK	100
WLAN-CH11	V	3	Horn SN6276	2462.00	70.50		30.34	5.16	-23.12	12.38	82.88	AV	100

Formulae:

Total CF = AF + CL + Other

Field Strength = SA Level + Total CF

<b>Applicant:</b>	Itronix Corporation	<b>Model:</b>	IX325A775IWLBT	<b>FCC ID:</b>	KBCIX325A775IWLBT	<b>IC ID:</b>	1943A-IX325e
<b>IX325 Rugged Tablet PC with internal Intel PRO2200BG 802.11b/g WLAN &amp; Well Green Dual Internal Antenna</b>							
2005 Celltech Labs Inc.	This document is not to be reproduced in whole or in part without the prior written permission of Celltech Labs Inc.						Page 24 of 59

	<b>Test Report Serial No.:</b>	060605KBC-T646-E15W	<b>Report Revision No.:</b>	Rev. 0
	<b>Test Date(s):</b>	4Jul05 - 20Jul05	<b>Report Issue Date:</b>	8Dec05
	<b>Test Standard(s):</b>	FCC 47 CFR §15.247	Industry Canada RSS-210 Issue 5	
	<b>Lab Registration(s):</b>	FCC Lab Reg. # 714830	Industry Canada Lab File #3874	

D.9.2. Mode b - Lower Band-edge Emission Field Strengths @ Specified Distance

Channel 1 Mode b - Conducted Peak Band-edge Plots

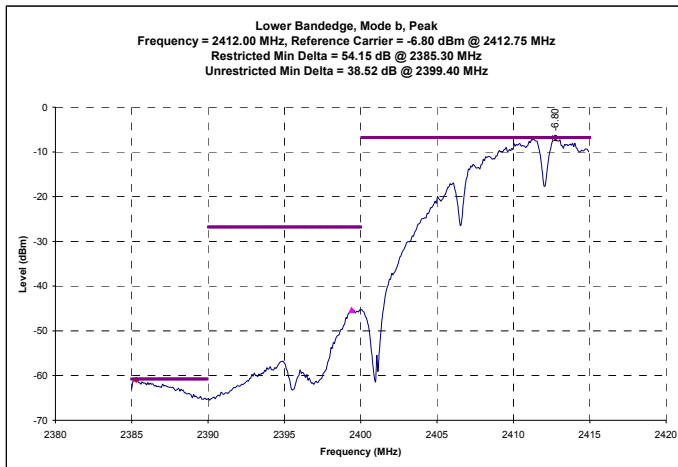

Channel 1 Mode b - Conducted Average Band-edge Plots

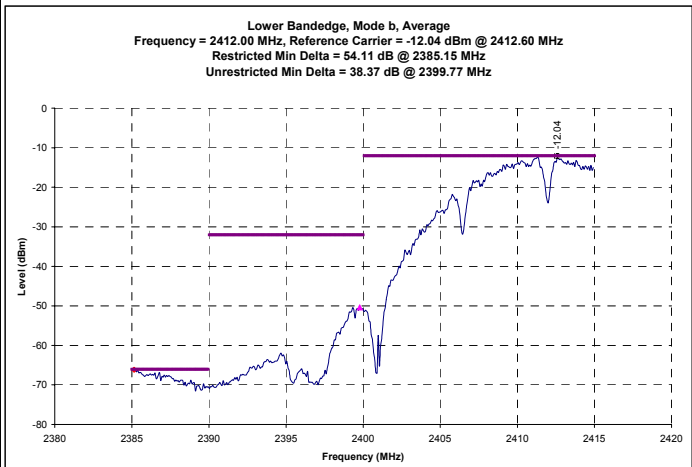

Channel 1 b - Calculated Band-edge (Unrestricted) Field Strengths

IX325 with Intel WLAN Mode b with Setting 27.0, Tx = 1 Mbps

Channel	Polarity	Distance	Frequency	Carrier Radiated Field Strength	Delta Marker	Detector	Calculated Bandedge Field Strength	Duty Cycle Correction	Corrected Bandedge Field Strength	Specified Limit	Specified Limit Distance	Limit Distance Correction	Calculated Limit	Margin	Pass/Fail
WLAN-CH1	H	3	2399.40	90.13	38.52	PK	51.61	0.00	51.61	71.03	3.00	0.00	71.03	19.42	PASS
WLAN-CH1	H	3	2399.77	79.13	38.37	AV	40.76	0.00	40.76	59.68	3.00	0.00	59.68	18.92	PASS
WLAN-CH1	V	3	2399.40	92.73	38.52	PK	54.21	0.00	54.21	74.13	3.00	0.00	74.13	19.92	PASS
WLAN-CH1	V	3	2399.77	81.73	38.37	AV	43.36	0.00	43.36	62.88	3.00	0.00	62.88	19.52	PASS

Formulae:

- Calculated Bandedge Field Strength (dBuV/m) = Carrier Radiated Field Strength (dBuV/m) + Delta Marker (dB)
- Duty Cycle Correction (dB) = 20 \* log (time on / total time)
- Corrected Bandedge Field Strength (dBuV/m) = Calculated Bandedge Field Strength (dBuV/m) + Duty Cycle Correction (dB)
- Limit Distance Correction = 20 \* log (measurement distance / limit distance)
- Calculated Limit (dBuV/m) = Specified Limit (dBuV/m) + Limit Distance Correction (dB)
- Margin (dB) = Corrected Limit (dBuV/m) - Corrected Bandedge Field Strength (dBuV/m)

**Note: Measurements and calculation reference the Marker-Delta Method described in FCC Public Notice DA 00-705  
 Limit based on highest radiated carrier**

<b>Applicant:</b>	Itronix Corporation	<b>Model:</b>	IX325A775IWLBT	<b>FCC ID:</b>	KBCIX325A775IWLBT	<b>IC ID:</b>	1943A-IX325e
<b>IX325 Rugged Tablet PC with internal Intel PRO2200BG 802.11b/g WLAN &amp; Well Green Dual Internal Antenna</b>							
2005 Celltech Labs Inc.	This document is not to be reproduced in whole or in part without the prior written permission of Celltech Labs Inc.						Page 25 of 59

	<b>Test Report Serial No.:</b>	060605KBC-T646-E15W	<b>Report Revision No.:</b>	Rev. 0
	<b>Test Date(s):</b>	4Jul05 - 20Jul05	<b>Report Issue Date:</b>	8Dec05
	<b>Test Standard(s):</b>	FCC 47 CFR §15.247	Industry Canada RSS-210 Issue 5	
	<b>Lab Registration(s):</b>	FCC Lab Reg. # 714830	Industry Canada Lab File #3874	

D.9.3. Mode b - Out-of-Band Spurious Emission Field Strengths @ Specified Distance (not within restricted bands)

Channel 1 - Mode b

		<b>Project Number:</b>	060605KBC-T643-E15W	<b>Standard:</b>	FCC15.247c
		<b>Company:</b>	Itronix	<b>Test Start Date:</b>	4-Jul-05
		<b>Product:</b>	IX325 with Intel PRO 2200BG	<b>Test End Date:</b>	13-Jul-05

Channel	Polarity	Distance	Rx Antenna	Frequency	SA Level	Noise Floor	Rx AF	Rx CL	Other Rx	Total Rx CF	Field Strength	Detector	Limit Distance	Limit Distance Correction	Calculated Limit	Margin	Pass/Fail
							dB/m	dB	dB	dB/m	dBuV/m	(PK/QP/AV)	m	dB	dBuV/m	dB	
WLAN-CH1	H	3	Horn SN6276	5768.07	33.70		36.61	8.45	-30.96	14.09	47.79	PK*	3.00	0.00	59.68	11.89	PASS
WLAN-CH1	H	3	Horn SN6276	<b>7236.00</b>	33.80	x	38.22	9.72	-30.84	17.10	50.90	PK*	3.00	0.00	59.68	8.77	PASS
WLAN-CH1	H	3	Horn SN6276	<b>9648.00</b>	33.80	x	40.30	12.00	-30.71	21.58	55.38	PK	3.00	0.00	71.03	15.64	PASS
WLAN-CH1	H	3	Horn SN6276	9648.00	22.20	x	40.30	12.00	-30.71	21.58	43.78	AV	3.00	0.00	59.68	15.89	PASS
WLAN-CH1	H	1	Horn SN6276	16891.85	40.86	x	42.76	10.76	-32.06	21.46	62.32	PK*	3.00	9.54	69.22	6.90	PASS
WLAN-CH1	H	1	Waveline_899	<b>21708.00</b>	37.49		40.30	12.52	-35.58	17.25	54.74	PK*	3.00	9.54	69.22	14.48	PASS
WLAN-CH1	V	3	Horn SN6276	4441.43	32.00	x	34.70	7.17	-31.07	10.80	42.80	PK*	3.00	0.00	62.88	20.08	PASS
WLAN-CH1	V	3	Horn SN6276	5255.02	37.30		36.11	8.17	-31.00	13.27	50.57	PK*	3.00	0.00	62.88	12.30	PASS
WLAN-CH1	V	3	Horn SN6276	<b>7236.00</b>	34.10	x	38.22	9.72	-30.84	17.10	51.20	PK*	3.00	0.00	62.88	11.67	PASS
WLAN-CH1	V	3	Horn SN6276	<b>9648.00</b>	33.70	x	40.30	12.00	-30.71	21.58	55.28	PK	3.00	0.00	74.13	18.84	PASS
WLAN-CH1	V	3	Horn SN6276	<b>9648.00</b>	22.30	x	40.30	12.00	-30.71	21.58	43.88	AV	3.00	0.00	62.88	18.99	PASS
WLAN-CH1	V	1	Horn SN6276	14340.75	39.96	x	42.44	9.67	-30.71	21.40	61.36	PK*	3.00	9.54	72.42	11.06	PASS
WLAN-CH1	V	1	Horn SN6276	14460.40	40.07	x	42.56	9.73	-30.77	21.51	61.58	PK*	3.00	9.54	72.42	10.84	PASS
WLAN-CH1	V	1	Horn SN6276	16874.05	39.68	x	42.72	10.75	-32.05	21.42	61.10	PK*	3.00	9.54	72.42	11.32	PASS
WLAN-CH1	V	1	Horn SN6276	17677.60	39.94	x	44.93	11.05	-32.48	23.50	63.44	PK	3.00	9.54	83.67	20.23	PASS
WLAN-CH1	V	1	Horn SN6276	17677.60	34.25	x	44.93	11.05	-32.48	23.50	57.75	AV	3.00	9.54	72.42	14.67	PASS
WLAN-CH1	V	1	Waveline_899	<b>21708.00</b>	36.78		40.30	12.52	-35.58	17.25	54.03	PK*	3.00	9.54	72.42	18.39	PASS

Notes:

\*PK denotes QP or Average limits applied to emissions measured with a peak detector

**BOLD** signifies the highest signal measured near a carrier harmonic frequency

No EUT emissions levels were measured above those reported

Formulae:

Total CF = Antenna Factor + Cable Factor + Other Factor (Amplifier Gain, filter loss, etc)

Field Strength = SA Reading + Total CF

Limit Distance Correction = 40\*log(d1/d2) for F<30 MHz, 20\*log(d1/d2) for F> 30 MHz:

where d1 is the measurement distance, d2 is the published limit distance

Limit = Specified Limit + Limit Distance Correction

Margin = Limit - Field Strength

**Limit based on highest radiated carrier**

<b>Applicant:</b>	Itronix Corporation	<b>Model:</b>	IX325A775IWLBT	<b>FCC ID:</b>	KBCIX325A775IWLBT	<b>IC ID:</b>	1943A-IX325e
<b>IX325 Rugged Tablet PC with internal Intel PRO2200BG 802.11b/g WLAN &amp; Well Green Dual Internal Antenna</b>							
2005 Celltech Labs Inc.	This document is not to be reproduced in whole or in part without the prior written permission of Celltech Labs Inc.						Page 26 of 59

 Testing and Engineering Services Lab	<b>Test Report Serial No.:</b>	060605KBC-T646-E15W	<b>Report Revision No.:</b>	Rev. 0
	<b>Test Date(s):</b>	4Jul05 - 20Jul05	<b>Report Issue Date:</b>	8Dec05
	<b>Test Standard(s):</b>	FCC 47 CFR §15.247	Industry Canada RSS-210 Issue 5	
	<b>Lab Registration(s):</b>	FCC Lab Reg. # 714830	Industry Canada Lab File #3874	

**Channel 6 - Mode b**

 Testing and Engineering Services Lab	<b>Project Number:</b>	060605KBC-T643-E15W	<b>Standard:</b>	FCC15.247c
	<b>Company:</b>	Itronix	<b>Test Start Date:</b>	4-Jul-05
	<b>Product:</b>	IX325 with Intel PRO 2200BG	<b>Test End Date:</b>	13-Jul-05

Channel	Polarity	Distance m	Rx Antenna	Frequency MHz	SA Level dBuV	Noise Floor	Rx AF	Rx CL	Other Rx	Total Rx CF	Field Strength	Detector	Limit Distance	Limit Distance Correction	Calculated Limit	Margin	Pass/Fail
							dB/m	dB	dB	dB/m	dBuV/m	(PK/QP/AV)	m	dB	dBuV/m	dB	
WLAN-CH6	H	3	Horn SN6276	3249.32	34.90		32.65	5.96	-31.17	7.44	42.34	PK*	3.00	0.00	59.68	17.33	PASS
WLAN-CH6	H	3	Horn SN6276	5764.06	39.60		36.61	8.41	-30.96	14.06	53.66	PK*	3.00	0.00	59.68	6.02	PASS
WLAN-CH6	H	3	Horn SN6276	<b>9748.00</b>	33.40	x	40.30	12.18	-30.71	21.77	55.17	PK	3.00	0.00	71.03	15.85	PASS
WLAN-CH6	H	3	Horn SN6276	<b>9748.00</b>	22.30	x	40.30	12.18	-30.71	21.77	44.07	AV	3.00	0.00	59.68	15.60	PASS
WLAN-CH6	H	1	Horn SN6276	14185.20	40.24	x	42.29	9.60	-30.63	21.26	61.50	PK*	3.00	9.54	69.22	7.72	PASS
WLAN-CH6	H	1	Horn SN6276	14619.85	40.00	x	42.58	9.80	-30.86	21.52	61.52	PK*	3.00	9.54	69.22	7.70	PASS
WLAN-CH6	H	1	Horn SN6276	<b>17061.05</b>	39.80	x	43.17	10.82	-32.15	21.84	61.64	PK*	3.00	9.54	69.22	7.58	PASS
WLAN-CH6	H	1	Waveline 899	<b>21933.00</b>	38.57	x	40.30	12.61	-35.58	17.33	55.90	PK*	3.00	9.54	69.22	13.32	PASS
WLAN-CH6	V	3	Horn SN6276	3249.00	34.30		32.65	5.96	-31.17	7.44	41.74	PK*	3.00	0.00	62.88	21.13	PASS
WLAN-CH6	V	3	Horn SN6276	5254.32	36.90		36.11	8.17	-31.00	13.27	50.17	PK*	3.00	0.00	62.88	12.71	PASS
WLAN-CH6	V	3	Horn SN6276	5255.78	35.50		36.11	8.18	-31.00	13.28	48.78	PK*	3.00	0.00	62.88	14.09	PASS
WLAN-CH6	V	3	Horn SN6276	<b>9748.00</b>	33.30	x	40.30	12.18	-30.71	21.77	55.07	PK*	3.00	0.00	62.88	7.80	PASS
WLAN-CH6	V	1	Horn SN6276	14108.15	40.63	x	42.21	9.56	-30.59	21.18	61.81	PK*	3.00	9.54	72.42	10.60	PASS
WLAN-CH6	V	1	Horn SN6276	<b>14622.00</b>	38.43	x	42.58	9.80	-30.86	21.52	59.95	PK*	3.00	9.54	72.42	12.47	PASS
WLAN-CH6	V	1	Horn SN6276	<b>17059.00</b>	37.39	x	43.17	10.82	-32.15	21.83	59.22	PK*	3.00	9.54	72.42	13.19	PASS
WLAN-CH6	V	1	Waveline_899	<b>21933.00</b>	39.09	x	40.30	12.61	-35.58	17.33	56.42	PK*	3.00	9.54	72.42	16.00	PASS

**Notes:**

\*PK denotes QP or Average limits applied to emissions measured with a peak detector

**BOLD** signifies the highest signal measured near a carrier harmonic frequency

No EUT emissions levels were measured above those reported

**Formulae:**

Total CF = Antenna Factor + Cable Factor + Other Factor (Amplifier Gain, filter loss, etc)

Field Strength = SA Reading + Total CF

Limit Distance Correction = 40\*log(d1/d2) for F<30 MHz, 20\*log(d1/d2) for F> 30 MHz:

where d1 is the measurement distance, d2 is the published limit distance

Limit = Specified Limit + Limit Distance Correction

Margin = Limit - Field Strength

**Limit based on highest radiated carrier**

<b>Applicant:</b>	Itronix Corporation	<b>Model:</b>	IX325A775IWLBT	<b>FCC ID:</b>	KBCIX325A775IWLBT	<b>IC ID:</b>	1943A-IX325e
<b>IX325 Rugged Tablet PC with internal Intel PRO2200BG 802.11b/g WLAN &amp; Well Green Dual Internal Antenna</b>							
2005 Celltech Labs Inc.	This document is not to be reproduced in whole or in part without the prior written permission of Celltech Labs Inc.						Page 27 of 59

 Testing and Engineering Services Lab	<b>Test Report Serial No.:</b>	060605KBC-T646-E15W	<b>Report Revision No.:</b>	Rev. 0
	<b>Test Date(s):</b>	4Jul05 - 20Jul05	<b>Report Issue Date:</b>	8Dec05
	<b>Test Standard(s):</b>	FCC 47 CFR §15.247	Industry Canada RSS-210 Issue 5	
	<b>Lab Registration(s):</b>	FCC Lab Reg. # 714830	Industry Canada Lab File #3874	

Channel 11 - Mode b																	
		<b>Project Number:</b>		060605KBC-T643-E15W				<b>Standard:</b>		FCC15.247c							
		<b>Company:</b>		Itronix				<b>Test Start Date:</b>		4-Jul-05							
		<b>Product:</b>		IX325 with Intel PRO 2200BG				<b>Test End Date:</b>		13-Jul-05							
Channel	Polarity	Distance	Rx Antenna	Frequency	SA Level	Noise Floor	Rx AF	Rx CL	Other Rx	Total Rx CF	Field Strength	Detector	Limit Distance	Limit Distance Correction	Calculated Limit	Margin	Pass/Fail
		m		MHz	dBuV		dB/m	dB	dB	dB/m	dBuV/m	(PK/QP/AV)	m	dB	dBuV/m	dB	
WLAN-CH11	H	3	Horn SN6276	5751.28	35.40		36.60	8.39	-30.96	14.02	49.42	PK*	3.00	0.00	59.68	10.25	PASS
WLAN-CH11	H	3	Horn SN6276	<b>9848.00</b>	33.30	x	40.30	12.42	-30.70	22.02	55.32	PK	3.00	0.00	71.03	15.70	PASS
WLAN-CH11	H	3	Horn SN6276	<b>9848.00</b>	22.40	x	40.30	12.42	-30.70	22.02	44.42	AV	3.00	0.00	59.68	15.25	PASS
WLAN-CH11	H	1	Horn SN6276	<b>14772.00</b>	38.03	x	42.55	9.87	-30.94	21.48	59.51	PK*	3.00	9.54	69.22	9.71	PASS
WLAN-CH11	H	1	Horn SN6276	<b>17234.00</b>	38.38	x	43.66	10.88	-32.24	22.30	60.68	PK*	3.00	9.54	69.22	8.54	PASS
WLAN-CH11	V	3	Horn SN6276	5336.43	30.40	x	36.24	8.47	-31.00	13.71	44.11	PK*	3.00	0.00	62.88	18.76	PASS
WLAN-CH11	V	3	Horn SN6276	<b>9848.00</b>	34.00	x	40.30	12.42	-30.70	22.02	56.02	PK*	3.00	0.00	62.88	6.85	PASS
WLAN-CH11	V	1	Horn SN6276	<b>14772.00</b>	38.32	x	42.55	9.87	-30.94	21.48	59.80	PK*	3.00	9.54	72.42	12.62	PASS
WLAN-CH11	V	1	Horn SN6276	<b>17234.00</b>	38.13	x	43.66	10.88	-32.24	22.30	60.43	PK*	3.00	9.54	72.42	11.99	PASS

**Notes:**  
 \*PK denotes QP or Average limits applied to emissions measured with a peak detector  
**BOLD** signifies the highest signal measured near a carrier harmonic frequency  
 No EUT emissions levels were measured above those reported  
**Formulae:**  
 Total CF = Antenna Factor + Cable Factor + Other Factor (Amplifier Gain, filter loss, etc)  
 Field Strength = SA Reading + Total CF  
 Limit Distance Correction = 40\*log(d1/d2) for F<30 MHz, 20\*log(d1/d2) for F> 30 MHz:  
 where d1 is the measurement distance, d2 is the published limit distance  
 Limit = Specified Limit + Limit Distance Correction  
 Margin = Limit - Field Strength

**Limit based on highest radiated carrier**

<b>Applicant:</b>	Itronix Corporation	<b>Model:</b>	IX325A775IWLBT	<b>FCC ID:</b>	KBCIX325A775IWLBT	<b>IC ID:</b>	1943A-IX325e
<b>IX325 Rugged Tablet PC with internal Intel PRO2200BG 802.11b/g WLAN &amp; Well Green Dual Internal Antenna</b>							
2005 Celltech Labs Inc.	This document is not to be reproduced in whole or in part without the prior written permission of Celltech Labs Inc.						Page 28 of 59



	<b>Test Report Serial No.:</b>	060605KBC-T646-E15W	<b>Report Revision No.:</b>	Rev. 0
	<b>Test Date(s):</b>	4Jul05 - 20Jul05	<b>Report Issue Date:</b>	8Dec05
	<b>Test Standard(s):</b>	FCC 47 CFR §15.247	Industry Canada RSS-210 Issue 5	
	<b>Lab Registration(s):</b>	FCC Lab Reg. # 714830	Industry Canada Lab File #3874	

D.9.4. Mode g - Fundamental Field Strengths @ Specified Distance (100 kHz RBW)

	<b>Project Num</b>	060605KBC-T643-E15W	<b>Standard:</b>	FCC15.247a
	<b>Company:</b>	Itronix	<b>Test Start Date:</b>	4-Jul-05
	<b>Product:</b>	IX325 with Intel PRO 2200BG	<b>Test End Date:</b>	13-Jul-05

IX325 with Intel WLAN Mode g with Setting 20, Tx = 6 Mbps Carrier Field Strengths

Channel	Polarity	Measurement Distance	Antenna	Frequency	SA Level	Noise Floor	AF	CL	Other	Total CF	Field Strength	Detector	RBW
							dB/m	dB	dB	dB/m	dBuV/m		kHz
WLAN-CH1	H	3	Horn SN6276	2412.00	71.45		30.26	5.10	-23.13	12.23	83.68	PK	100
WLAN-CH1	H	3	Horn SN6276	2412.00	61.50		30.26	5.10	-23.13	12.23	73.73	AV	100
WLAN-CH1	V	3	Horn SN6276	2412.00	69.40		30.26	5.10	-23.13	12.23	81.63	PK	100
WLAN-CH1	V	3	Horn SN6276	2412.00	59.35		30.26	5.10	-23.13	12.23	71.58	AV	100
WLAN-CH6	H	3	Horn SN6276	2437.00	72.55		30.30	5.14	-23.12	12.31	84.86	PK	100
WLAN-CH6	H	3	Horn SN6276	2437.00	62.20		30.30	5.14	-23.12	12.31	74.51	AV	100
WLAN-CH6	V	3	Horn SN6276	2437.00	69.35		30.30	5.14	-23.12	12.31	81.66	PK	100
WLAN-CH6	V	3	Horn SN6276	2437.00	59.55		30.30	5.14	-23.12	12.31	71.86	AV	100
WLAN-CH11	H	3	Horn SN6276	2462.00	73.70		30.34	5.16	-23.12	12.38	86.08	PK	100
WLAN-CH11	H	3	Horn SN6276	2462.00	63.45		30.34	5.16	-23.12	12.38	75.83	AV	100
WLAN-CH11	V	3	Horn SN6276	2462.00	71.20		30.34	5.16	-23.12	12.38	83.58	PK	100
WLAN-CH11	V	3	Horn SN6276	2462.00	61.00		30.34	5.16	-23.12	12.38	73.38	AV	100

Formulae:  
Total CF = AF + CL + Other  
Field Strength = SA Level + Total CF

<b>Applicant:</b>	Itronix Corporation	<b>Model:</b>	IX325A775IWLBT	<b>FCC ID:</b>	KBCIX325A775IWLBT	<b>IC ID:</b>	1943A-IX325e
IX325 Rugged Tablet PC with internal Intel PRO2200BG 802.11b/g WLAN & Well Green Dual Internal Antenna							
2005 Celltech Labs Inc.	This document is not to be reproduced in whole or in part without the prior written permission of Celltech Labs Inc.						Page 29 of 59



<b>Test Report Serial No.:</b>	060605KBC-T646-E15W	<b>Report Revision No.:</b>	Rev. 0
<b>Test Date(s):</b>	4Jul05 - 20Jul05	<b>Report Issue Date:</b>	8Dec05
<b>Test Standard(s):</b>	FCC 47 CFR §15.247	<b>Industry Canada RSS-210 Issue 5</b>	
<b>Lab Registration(s):</b>	FCC Lab Reg. # 714830	<b>Industry Canada Lab File #3874</b>	

### D.9.5. Mode g - Lower Band-edge Emission Field Strengths @ Specified Distance

Channel 1 Mode g - Conducted Peak Band-edge Plots

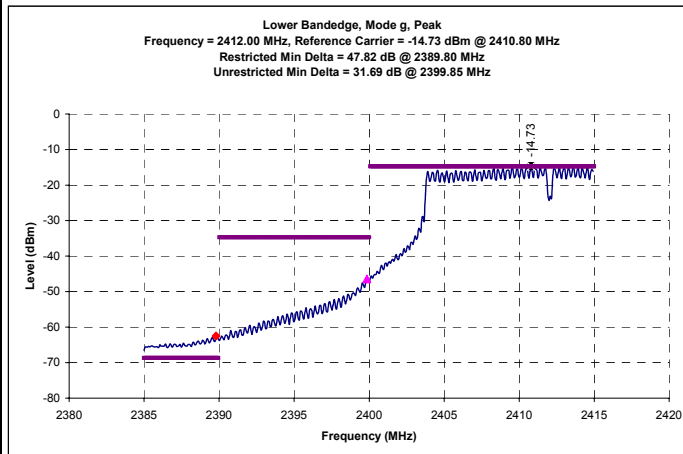

Channel 1 Mode g - Conducted Average Band-edge Plots

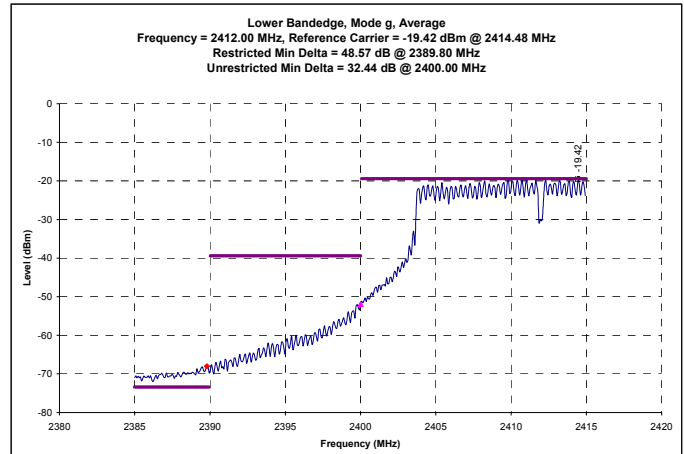

### Channel 1 g – Calculated Band-edge (Unrestricted) Field Strengths

IX325 with Intel WLAN Mode g with Setting 20, Tx = 6 Mbps

Channel	Polarity	Distance	Frequency	Carrier Radiated Field Strength	Delta Marker	Detector	Calculated Bandedge Field Strength	Duty Cycle Correction	Corrected Bandedge Field Strength	Specified Limit	Specified Limit Distance	Limit Distance Correction	Calculated Limit	Margin	Pass/Fail
WLAN-CH1	H	3	2399.85	83.68	31.69	PK	51.99	0.00	51.99	66.08	3.00	0.00	66.08	14.09	PASS
WLAN-CH1	H	3	2400.00	73.73	32.44	AV	41.29	0.00	41.29	55.83	3.00	0.00	55.83	14.54	PASS
WLAN-CH1	V	3	2399.85	81.63	31.69	PK	49.94	0.00	49.94	63.58	3.00	0.00	63.58	13.64	PASS
WLAN-CH1	V	3	2400.00	71.58	32.44	AV	39.14	0.00	39.14	53.38	3.00	0.00	53.38	14.24	PASS

**Formulae:**

- Calculated Bandedge Field Strength (dBuV/m) = Carrier Radiated Field Strength (dBuV/m) + Delta Marker (dB)
- Duty Cycle Correction (dB) = 20 \* log (time on / total time)
- Corrected Bandedge Field Strength (dBuV/m) = Calculated Bandedge Field Strength (dBuV/m) + Duty Cycle Correction (dB)
- Limit Distance Correction = 20 \* log (measurement distance / limit distance)
- Calculated Limit (dBuV/m) = Specified Limit (dBuV/m) + Limit Distance Correction (dB)
- Margin (dB) = Corrected Limit (dBuV/m) – Corrected Bandedge Field Strength (dBuV/m)

**Note: Measurements and calculation reference the Marker-Delta Method described in FCC Public Notice DA 00-705  
 Limit based on highest radiated carrier**

	<b>Test Report Serial No.:</b>	060605KBC-T646-E15W	<b>Report Revision No.:</b>	Rev. 0
	<b>Test Date(s):</b>	4Jul05 - 20Jul05	<b>Report Issue Date:</b>	8Dec05
	<b>Test Standard(s):</b>	FCC 47 CFR §15.247	Industry Canada RSS-210 Issue 5	
	<b>Lab Registration(s):</b>	FCC Lab Reg. # 714830	Industry Canada Lab File #3874	

D.9.6. Mode g - Out-of-Band Spurious Emission Field Strengths @ Specified Distance (not within restricted bands)

Channel 1 - Mode g

		<b>Project Number:</b>	060605KBC-T643-E15W		<b>Standard:</b>	FCC15.209	
		<b>Company:</b>	Itronix		<b>Test Start Date:</b>	4-Jul-05	
		<b>Product:</b>	IX325 with Intel PRO 2200BG		<b>Test End Date:</b>	13-Jul-05	

Channel	Polarity	Distance m	Rx Antenna	Frequency MHz	SA Level dBuV	Noise Floor	Rx AF	Rx CL	Other Rx	Total Rx CF	Field Strength	Detector	Limit Distance	Limit Distance Correction	Calculated Limit	Margin	Pass/Fail
							dB/m	dB	dB	dB/m	dBuV/m	(PK/QP/AV)	m	dB	dBuV/m	dB	
WLAN-CH1	H	3	Horn SN6276	5763.87	33.40		36.61	8.41	-30.96	14.06	47.46	PK*	3.00	0.00	53.98	6.52	PASS
WLAN-CH1	H	3	Horn SN6276	<b>7236.00</b>	33.80	x	38.22	9.72	-30.84	17.10	50.90	PK*	3.00	0.00	53.98	3.08	PASS
WLAN-CH1	H	3	Horn SN6276	<b>9648.00</b>	33.00	x	40.30	12.00	-30.71	21.58	54.58	PK	3.00	0.00	73.98	19.40	PASS
WLAN-CH1	H	3	Horn SN6276	<b>9648.00</b>	22.00	x	40.30	12.00	-30.71	21.58	43.58	AV	3.00	0.00	53.98	10.40	PASS
WLAN-CH1	H	1	Horn SN6276	14139.50	39.67	x	42.24	9.58	-30.60	21.21	60.88	PK*	3.00	9.54	63.52	2.64	PASS
WLAN-CH1	H	1	Horn SN6276	<b>16884.00</b>	40.07	x	42.74	10.76	-32.06	21.44	61.51	PK*	3.00	9.54	63.52	2.01	PASS
WLAN-CH1	H	1	Waveline_899	<b>21708.00</b>	38.08	x	40.30	12.52	-35.58	17.25	55.33	PK*	3.00	9.54	63.52	8.20	PASS
WLAN-CH1	V	3	Horn SN6276	5786.75	30.10	x	36.61	8.53	-30.96	14.18	44.28	PK*	3.00	0.00	53.98	9.70	PASS
WLAN-CH1	V	3	Horn SN6276	<b>7236.00</b>	34.20	x	38.22	9.72	-30.84	17.10	51.30	PK*	3.00	0.00	53.98	2.68	PASS
WLAN-CH1	V	3	Horn SN6276	<b>9648.00</b>	33.60	x	40.30	12.00	-30.71	21.58	55.18	PK	3.00	0.00	73.98	18.80	PASS
WLAN-CH1	V	3	Horn SN6276	<b>9648.00</b>	22.30	x	40.30	12.00	-30.71	21.58	43.88	AV	3.00	0.00	53.98	10.10	PASS
WLAN-CH1	V	1	Horn SN6276	14402.80	40.17	x	42.50	9.70	-30.74	21.46	61.63	PK*	3.00	9.54	63.52	1.89	PASS
WLAN-CH1	V	1	Horn SN6276	<b>16884.00</b>	37.81	x	42.74	10.76	-32.06	21.44	59.25	PK*	3.00	9.54	63.52	4.27	PASS
WLAN-CH1	V	1	Waveline_899	<b>21708.00</b>	38.59	x	40.30	12.52	-35.58	17.25	55.84	PK*	3.00	9.54	63.52	7.69	PASS

**Notes:**

\*PK denotes QP or Average limits applied to emissions measured with a peak detector

**BOLD** signifies the highest signal measured near a carrier harmonic frequency

No EUT emissions levels were measured above those reported

Formulae:

Total CF = Antenna Factor + Cable Factor + Other Factor (Amplifier Gain, filter loss, etc)

Field Strength = SA Reading + Total CF

Limit Distance Correction = 40\*log(d1/d2) for F<30 MHz, 20\*log(d1/d2) for F> 30 MHz:

where d1 is the measurement distance, d2 is the published limit distance

Limit = Specified Limit + Limit Distance Correction

Margin = Limit - Field Strength

**Limit based on highest radiated carrier**

<b>Applicant:</b>	Itronix Corporation	<b>Model:</b>	IX325A775IWLBT	<b>FCC ID:</b>	KBCIX325A775IWLBT	<b>IC ID:</b>	1943A-IX325e
<b>IX325 Rugged Tablet PC with internal Intel PRO2200BG 802.11b/g WLAN &amp; Well Green Dual Internal Antenna</b>							
2005 Celltech Labs Inc.	This document is not to be reproduced in whole or in part without the prior written permission of Celltech Labs Inc.						Page 31 of 59

	<b>Test Report Serial No.:</b>	060605KBC-T646-E15W	<b>Report Revision No.:</b>	Rev. 0
	<b>Test Date(s):</b>	4Jul05 - 20Jul05	<b>Report Issue Date:</b>	8Dec05
	<b>Test Standard(s):</b>	FCC 47 CFR §15.247	Industry Canada RSS-210 Issue 5	
	<b>Lab Registration(s):</b>	FCC Lab Reg. # 714830	Industry Canada Lab File #3874	

Channel 6 - Mode g

		<b>Project Number:</b> 060605KBC-T643-E15W <b>Company:</b> Itronix <b>Product:</b> IX325 with Intel PRO 2200BG	<b>Standard:</b> FCC15.209 <b>Test Start Date:</b> 4-Jul-05 <b>Test End Date:</b> 13-Jul-05														
Channel	Polarity	Distance	Rx Antenna	Frequency	SA Level	Noise Floor	Rx AF	Rx CL	Other Rx	Total Rx CF	Field Strength	Detector	Limit Distance	Limit Distance Correction	Calculated Limit	Margin	Pass/Fail
		m		MHz	dBuV		dB/m	dB	dB	dB/m	dBuV/m	(PK/QP/AV)	m	dB	dBuV/m	dB	
WLAN-CH6	H	3	Horn SN6276	5766.72	36.30		36.61	8.43	-30.96	14.08	50.38	PK*	3.00	0.00	53.98	3.60	PASS
WLAN-CH6	H	3	Horn SN6276	<b>9748.00</b>	33.50	x	40.30	12.18	-30.71	21.77	55.27	PK	3.00	0.00	73.98	18.71	PASS
WLAN-CH6	H	3	Horn SN6276	<b>9748.00</b>	22.10	x	40.30	12.18	-30.71	21.77	43.87	AV	3.00	0.00	53.98	10.11	PASS
WLAN-CH6	H	1	Horn SN6276	<b>14622.00</b>	37.80	x	42.58	9.80	-30.86	21.52	59.32	PK*	3.00	9.54	63.52	4.21	PASS
WLAN-CH6	H	1	Horn SN6276	15037.35	39.56	x	42.37	9.99	-31.08	21.28	60.84	PK*	3.00	9.54	63.52	2.68	PASS
WLAN-CH6	H	1	Horn SN6276	<b>17059.00</b>	39.75	x	43.17	10.82	-32.15	21.83	61.58	PK	3.00	9.54	63.52	21.94	PASS
WLAN-CH6	H	1	Waveline_899	<b>21933.00</b>	38.48		40.30	12.61	-35.58	17.33	55.81	PK*	3.00	9.54	63.52	7.71	PASS
WLAN-CH6	V	3	Horn SN6276	3254.00	31.30	x	32.66	5.97	-31.17	7.46	38.76	PK*	3.00	0.00	53.98	15.22	PASS
WLAN-CH6	V	3	Horn SN6276	<b>9748.00</b>	34.90	x	40.30	12.18	-30.71	21.77	56.67	PK	3.00	0.00	73.98	17.31	PASS
WLAN-CH6	V	3	Horn SN6276	<b>9748.00</b>	22.50	x	40.30	12.18	-30.71	21.77	44.27	AV	3.00	0.00	53.98	9.71	PASS
WLAN-CH6	V	1	Horn SN6276	<b>14622.00</b>	37.23	x	42.58	9.80	-30.86	21.52	58.75	PK*	3.00	9.54	63.52	4.78	PASS
WLAN-CH6	V	1	Horn SN6276	<b>17059.00</b>	36.81	x	43.17	10.82	-32.15	21.83	58.64	PK*	3.00	9.54	63.52	4.88	PASS
WLAN-CH6	V	1	Waveline_899	<b>21933.00</b>	37.75		40.30	12.61	-35.58	17.33	55.08	PK*	3.00	9.54	63.52	8.44	PASS

**Notes:**  
 \*PK denotes QP or Average limits applied to emissions measured with a peak detector  
**BOLD** signifies the highest signal measured near a carrier harmonic frequency  
 No EUT emissions levels were measured above those reported  
**Formulae:**  
 Total CF = Antenna Factor + Cable Factor + Other Factor (Amplifier Gain, filter loss, etc)  
 Field Strength = SA Reading + Total CF  
 Limit Distance Correction = 40\*log(d1/d2) for F<30 MHz, 20\*log(d1/d2) for F> 30 MHz:  
 where d1 is the measurement distance, d2 is the published limit distance  
 Limit = Specified Limit + Limit Distance Correction  
 Margin = Limit - Field Strength  
**Limit based on highest radiated carrier**

<b>Applicant:</b>	Itronix Corporation	<b>Model:</b>	IX325A775IWLBT	<b>FCC ID:</b>	KBCIX325A775IWLBT	<b>IC ID:</b>	1943A-IX325e
IX325 Rugged Tablet PC with internal Intel PRO2200BG 802.11b/g WLAN & Well Green Dual Internal Antenna							
2005 Celltech Labs Inc.	This document is not to be reproduced in whole or in part without the prior written permission of Celltech Labs Inc.						Page 32 of 59

	<b>Test Report Serial No.:</b>	060605KBC-T646-E15W	<b>Report Revision No.:</b>	Rev. 0
	<b>Test Date(s):</b>	4Jul05 - 20Jul05	<b>Report Issue Date:</b>	8Dec05
	<b>Test Standard(s):</b>	FCC 47 CFR §15.247	Industry Canada RSS-210 Issue 5	
	<b>Lab Registration(s):</b>	FCC Lab Reg. # 714830	Industry Canada Lab File #3874	

Channel 11 - Mode g

		<b>Project Number:</b> 060605KBC-T643-E15W <b>Company:</b> Itronix <b>Product:</b> IX325 with Intel PRO 2200BG	<b>Standard:</b> FCC15.209 <b>Test Start Date:</b> 4-Jul-05 <b>Test End Date:</b> 13-Jul-05														
Channel	Polarity	Distance	Rx Antenna	Frequency	SA Level	Noise Floor	Rx AF	Rx CL	Other Rx	Total Rx CF	Field Strength	Detector	Limit Distance	Limit Distance Correction	Calculated Limit	Margin	Pass/Fail
		m		MHz	dBuV		dB/m	dB	dB	dB/m	dBuV/m	(PK/QP/AV)	m	dB	dBuV/m	dB	
WLAN-CH11	H	3	Horn SN6276	2524.31	34.10	x	30.48	5.24	-23.12	12.60	46.70	PK*	3.00	0.00	53.98	7.28	PASS
WLAN-CH11	H	3	Horn SN6276	5750.93	33.20		36.60	8.39	-30.96	14.02	47.22	PK*	3.00	0.00	53.98	6.76	PASS
WLAN-CH11	H	3	Horn SN6276	<b>9848.00</b>	34.00	x	40.30	12.42	-30.70	22.02	56.02	PK	3.00	0.00	73.98	17.96	PASS
WLAN-CH11	H	3	Horn SN6276	<b>9848.00</b>	22.30	x	40.30	12.42	-30.70	22.02	44.32	AV	3.00	0.00	53.98	9.66	PASS
WLAN-CH11	H	1	Horn SN6276	14317.05	38.98	x	42.42	9.66	-30.70	21.38	60.36	PK*	3.00	9.54	63.52	3.16	PASS
WLAN-CH11	H	1	Horn SN6276	<b>14772.00</b>	37.03	x	42.55	9.87	-30.94	21.48	58.51	PK*	3.00	9.54	63.52	5.02	PASS
WLAN-CH11	H	1	Horn SN6276	<b>17234.00</b>	36.84	x	43.66	10.88	-32.24	22.30	59.14	PK*	3.00	9.54	63.52	4.39	PASS
WLAN-CH11	V	3	Horn SN6276	8993.84	35.90	x	40.19	10.96	-30.74	20.41	56.31	PK	3.00	0.00	73.98	17.67	PASS
WLAN-CH11	V	3	Horn SN6276	8993.84	22.00	x	40.19	10.96	-30.74	20.41	42.41	AV	3.00	0.00	53.98	11.57	PASS
WLAN-CH11	V	3	Horn SN6276	<b>9848.00</b>	35.50	x	40.30	12.42	-30.70	22.02	57.52	PK	3.00	0.00	73.98	16.46	PASS
WLAN-CH11	V	3	Horn SN6276	<b>9848.00</b>	22.70	x	40.30	12.42	-30.70	22.02	44.72	AV	3.00	0.00	53.98	9.26	PASS
WLAN-CH11	V	1	Horn SN6276	<b>14772.00</b>	36.79	x	42.55	9.87	-30.94	21.48	58.27	PK*	3.00	9.54	63.52	5.26	PASS
WLAN-CH11	V	1	Horn SN6276	<b>17234.00</b>	37.45	x	43.66	10.88	-32.24	22.30	59.75	PK*	3.00	9.54	63.52	3.78	PASS

**Notes:**  
 \*PK denotes QP or Average limits applied to emissions measured with a peak detector  
**BOLD** signifies the highest signal measured near a carrier harmonic frequency  
 No EUT emissions levels were measured above those reported  
**Formulae:**  
 Total CF = Antenna Factor + Cable Factor + Other Factor (Amplifier Gain, filter loss, etc)  
 Field Strength = SA Reading + Total CF  
 Limit Distance Correction = 40\*log(d1/d2) for F<30 MHz, 20\*log(d1/d2) for F> 30 MHz:  
 where d1 is the measurement distance, d2 is the published limit distance  
 Limit = Specified Limit + Limit Distance Correction  
 Margin = Limit - Field Strength  
**Limit based on highest radiated carrier**

<b>Applicant:</b>	Itronix Corporation	<b>Model:</b>	IX325A775IWLBT	<b>FCC ID:</b>	KBCIX325A775IWLBT	<b>IC ID:</b>	1943A-IX325e
IX325 Rugged Tablet PC with internal Intel PRO2200BG 802.11b/g WLAN & Well Green Dual Internal Antenna							
2005 Celltech Labs Inc.	This document is not to be reproduced in whole or in part without the prior written permission of Celltech Labs Inc.						Page 33 of 59

	<b>Test Report Serial No.:</b>	060605KBC-T646-E15W	<b>Report Revision No.:</b>	Rev. 0
	<b>Test Date(s):</b>	4Jul05 - 20Jul05	<b>Report Issue Date:</b>	8Dec05
	<b>Test Standard(s):</b>	FCC 47 CFR §15.247	Industry Canada RSS-210 Issue 5	
	<b>Lab Registration(s):</b>	FCC Lab Reg. # 714830	Industry Canada Lab File #3874	

#### D.10. PASS/FAIL

In reference to the results outlined in E.9, the DUT passes the requirements as stated in the reference standards as follows:

FCC 15.247 (c): All emissions within any 100 kHz bandwidth outside the operating frequency band are greater than 20 dB below the maximum 100 kHz bandwidth signal within the operating band.

#### D.11. SIGN-OFF

I attest to the accuracy of the data. All measurements reported herein were performed by me and are correct to the best of my knowledge and belief. I assume full responsibility for the completeness of these measurements.



\_\_\_\_\_  
 Russell Pipe  
 Senior Compliance Technologist  
 Celltech Labs Inc.

\_\_\_\_\_  
 13Jul05

Date

<b>Applicant:</b>	Itronix Corporation	<b>Model:</b>	IX325A775IWLBT	<b>FCC ID:</b>	KBCIX325A775IWLBT	<b>IC ID:</b>	1943A-IX325e
IX325 Rugged Tablet PC with internal Intel PRO2200BG 802.11b/g WLAN & Well Green Dual Internal Antenna							
2005 Celltech Labs Inc.	This document is not to be reproduced in whole or in part without the prior written permission of Celltech Labs Inc.						Page 34 of 59

	<b>Test Report Serial No.:</b>	060605KBC-T646-E15W	<b>Report Revision No.:</b>	Rev. 0
	<b>Test Date(s):</b>	4Jul05 - 20Jul05	<b>Report Issue Date:</b>	8Dec05
	<b>Test Standard(s):</b>	FCC 47 CFR §15.247	Industry Canada RSS-210 Issue 5	
	<b>Lab Registration(s):</b>	FCC Lab Reg. # 714830	Industry Canada Lab File #3874	

### Appendix E - Restricted Band Emissions Measurement

E.1. REFERENCES	
<b>Normative Reference Standard</b>	FCC CFR 47 §15.205 (a) (b), FCC CFR 47 §15.209 (a)
<b>Procedure Reference</b>	FCC 97-114

E.2. LIMITS																																																																									
FCC CFR 47 §15.205	<p>(a) Except as shown in paragraph (d) of this section, only spurious emissions are permitted in any of the frequency bands listed below:</p> <table border="1" style="width: 100%; border-collapse: collapse;"> <thead> <tr> <th style="width: 25%;">MHz</th> <th style="width: 25%;">MHz</th> <th style="width: 25%;">MHz</th> <th style="width: 25%;">GHz</th> </tr> </thead> <tbody> <tr><td>0.090-0.110</td><td>16.42-16.423</td><td>399.9-410</td><td>4.5-5.15</td></tr> <tr><td>0.495-0.505</td><td>16.69475-16.69525</td><td>608-614</td><td>5.35-5.46</td></tr> <tr><td>2.1735-2.1905</td><td>16.80425-16.80475</td><td>960-1240</td><td>7.25-7.75</td></tr> <tr><td>4.125-4.128</td><td>25.5-25.67</td><td>1300-1427</td><td>8.025-8.5</td></tr> <tr><td>4.17725-4.17775</td><td>37.5-38.25</td><td>1435-1626.5</td><td>9.0-9.2</td></tr> <tr><td>4.20725-4.20775</td><td>73-74.6</td><td>1645.5-1646.5</td><td>9.3-9.5</td></tr> <tr><td>6.215-6.218</td><td>74.8-75.2</td><td>1660-1710</td><td>10.6-12.7</td></tr> <tr><td>6.26775-6.26825</td><td>108-121.94</td><td>1718.8-1722.2</td><td>13.25-13.4</td></tr> <tr><td>6.31175-6.31225</td><td>123-138</td><td>2200-2300</td><td>14.47-14.5</td></tr> <tr><td>8.291-8.294</td><td>149.9-150.05</td><td>2310-2390</td><td>15.35-16.2</td></tr> <tr><td>8.362-8.366</td><td>156.52475-156.52525</td><td>2483.5-2500</td><td>17.7-21.4</td></tr> <tr><td>8.37625-8.38675</td><td>156.7-156.9</td><td>2655-2900</td><td>22.01-23.12</td></tr> <tr><td>8.41425-8.41475</td><td>162.0125-167.17</td><td>3260-3267</td><td>23.6-24.0</td></tr> <tr><td>12.29-12.293</td><td>167.72-173.2</td><td>3332-3339</td><td>31.2-31.8</td></tr> <tr><td>12.51975-12.52025</td><td>240-285</td><td>3345.8-3358</td><td>36.43-36.5</td></tr> <tr><td>12.57675-12.57725</td><td>322-335.4</td><td>3600-4400</td><td>(<sup>2</sup>)</td></tr> <tr><td>13.36-13.41</td><td></td><td></td><td></td></tr> </tbody> </table> <p><sup>1</sup> Until February 1, 1999, this restricted band shall be 0.490-0.510 MHz.  <sup>2</sup> Above 38.6</p> <p>(b) Except as provided in paragraphs (d) and (e), the field strength of emissions appearing within these frequency bands shall not exceed the limits shown in 15.209. At frequencies equal to or less than 1000 MHz, compliance with the limits in Section 15.209 shall be demonstrated using measurement instrumentation employing a CISPR quasi-peak detector. Above 1000 MHz, compliance with the emission limits in Section 15.209 shall be demonstrated based on the average value of the measured emissions. The provisions of 15.35 apply to these measurements.</p>	MHz	MHz	MHz	GHz	0.090-0.110	16.42-16.423	399.9-410	4.5-5.15	0.495-0.505	16.69475-16.69525	608-614	5.35-5.46	2.1735-2.1905	16.80425-16.80475	960-1240	7.25-7.75	4.125-4.128	25.5-25.67	1300-1427	8.025-8.5	4.17725-4.17775	37.5-38.25	1435-1626.5	9.0-9.2	4.20725-4.20775	73-74.6	1645.5-1646.5	9.3-9.5	6.215-6.218	74.8-75.2	1660-1710	10.6-12.7	6.26775-6.26825	108-121.94	1718.8-1722.2	13.25-13.4	6.31175-6.31225	123-138	2200-2300	14.47-14.5	8.291-8.294	149.9-150.05	2310-2390	15.35-16.2	8.362-8.366	156.52475-156.52525	2483.5-2500	17.7-21.4	8.37625-8.38675	156.7-156.9	2655-2900	22.01-23.12	8.41425-8.41475	162.0125-167.17	3260-3267	23.6-24.0	12.29-12.293	167.72-173.2	3332-3339	31.2-31.8	12.51975-12.52025	240-285	3345.8-3358	36.43-36.5	12.57675-12.57725	322-335.4	3600-4400	( <sup>2</sup> )	13.36-13.41			
MHz	MHz	MHz	GHz																																																																						
0.090-0.110	16.42-16.423	399.9-410	4.5-5.15																																																																						
0.495-0.505	16.69475-16.69525	608-614	5.35-5.46																																																																						
2.1735-2.1905	16.80425-16.80475	960-1240	7.25-7.75																																																																						
4.125-4.128	25.5-25.67	1300-1427	8.025-8.5																																																																						
4.17725-4.17775	37.5-38.25	1435-1626.5	9.0-9.2																																																																						
4.20725-4.20775	73-74.6	1645.5-1646.5	9.3-9.5																																																																						
6.215-6.218	74.8-75.2	1660-1710	10.6-12.7																																																																						
6.26775-6.26825	108-121.94	1718.8-1722.2	13.25-13.4																																																																						
6.31175-6.31225	123-138	2200-2300	14.47-14.5																																																																						
8.291-8.294	149.9-150.05	2310-2390	15.35-16.2																																																																						
8.362-8.366	156.52475-156.52525	2483.5-2500	17.7-21.4																																																																						
8.37625-8.38675	156.7-156.9	2655-2900	22.01-23.12																																																																						
8.41425-8.41475	162.0125-167.17	3260-3267	23.6-24.0																																																																						
12.29-12.293	167.72-173.2	3332-3339	31.2-31.8																																																																						
12.51975-12.52025	240-285	3345.8-3358	36.43-36.5																																																																						
12.57675-12.57725	322-335.4	3600-4400	( <sup>2</sup> )																																																																						
13.36-13.41																																																																									
FCC CFR 47 §15.209	<p>(a) Except as provided elsewhere in this Subpart, the emissions from an intentional radiator shall not exceed the field strength levels specified in the following table:</p> <table border="1" style="width: 100%; border-collapse: collapse;"> <thead> <tr> <th rowspan="2" style="width: 30%;">Frequency</th> <th colspan="2" style="width: 40%;">Field Strength</th> <th style="width: 30%;">Measurement Distance</th> </tr> <tr> <th style="width: 10%;">MHz</th> <th style="width: 10%;">uV/m</th> <th style="width: 10%;">dBuV/m</th> <th style="width: 10%;">Meters</th> </tr> </thead> <tbody> <tr> <td>.009 - 0.490</td> <td>2400/F(kHz)</td> <td>48.52 - 13.80</td> <td>300</td> </tr> <tr> <td>0.490 - 1.705</td> <td>24000/F(kHz)</td> <td>33.80 - 22.97</td> <td>30</td> </tr> <tr> <td>1.705 - 30.0</td> <td>30</td> <td>29.54</td> <td>30</td> </tr> <tr> <td>30 - 88</td> <td>100</td> <td>40.00</td> <td>3</td> </tr> <tr> <td>88 - 216</td> <td>150</td> <td>43.52</td> <td>3</td> </tr> <tr> <td>216 - 960</td> <td>200</td> <td>46.02</td> <td>3</td> </tr> <tr> <td>Above 960</td> <td>500</td> <td>53.98</td> <td>3</td> </tr> </tbody> </table> <p>(b) In the emission table above, the tighter limit applies at the band edges.</p>	Frequency	Field Strength		Measurement Distance	MHz	uV/m	dBuV/m	Meters	.009 - 0.490	2400/F(kHz)	48.52 - 13.80	300	0.490 - 1.705	24000/F(kHz)	33.80 - 22.97	30	1.705 - 30.0	30	29.54	30	30 - 88	100	40.00	3	88 - 216	150	43.52	3	216 - 960	200	46.02	3	Above 960	500	53.98	3																																				
Frequency	Field Strength		Measurement Distance																																																																						
	MHz	uV/m	dBuV/m	Meters																																																																					
.009 - 0.490	2400/F(kHz)	48.52 - 13.80	300																																																																						
0.490 - 1.705	24000/F(kHz)	33.80 - 22.97	30																																																																						
1.705 - 30.0	30	29.54	30																																																																						
30 - 88	100	40.00	3																																																																						
88 - 216	150	43.52	3																																																																						
216 - 960	200	46.02	3																																																																						
Above 960	500	53.98	3																																																																						

<b>Applicant:</b>	Itronix Corporation	<b>Model:</b>	IX325A775IWLBT	<b>FCC ID:</b>	KBCIX325A775IWLBT	<b>IC ID:</b>	1943A-IX325e
<b>IX325 Rugged Tablet PC with internal Intel PRO2200BG 802.11b/g WLAN &amp; Well Green Dual Internal Antenna</b>							
2005 Celltech Labs Inc.	This document is not to be reproduced in whole or in part without the prior written permission of Celltech Labs Inc.						Page 35 of 59

	<b>Test Report Serial No.:</b>	060605KBC-T646-E15W	<b>Report Revision No.:</b>	Rev. 0
	<b>Test Date(s):</b>	4Jul05 - 20Jul05	<b>Report Issue Date:</b>	8Dec05
	<b>Test Standard(s):</b>	FCC 47 CFR §15.247	Industry Canada RSS-210 Issue 5	
	<b>Lab Registration(s):</b>	FCC Lab Reg. # 714830	Industry Canada Lab File #3874	

### E.3. ENVIRONMENTAL CONDITIONS

<b>Temperature</b>	274 +/- 2 °C
<b>Humidity</b>	33 +/- 2 %
<b>Barometric Pressure</b>	96 +/- 0.2 kPa

### E.4. EQUIPMENT LIST

RECEIVING EQUIPMENT						
ID	ASSET NUMBER	MANUFACTURER	MODEL	DESCRIPTION	LAST CAL	CAL DUE
1	00072	EMCO	2075	Mini-mast	na	na
2	00073	EMCO	2080	Turn Table	na	na
3	00071	EMCO	2090	Multi-Device Controller	na	na
4	00085	EMCO	6502	Loop Antenna	10Aug04	10Aug05
5	00050	Chase	CBL-6111A	Bilog Antenna	08Feb05	08Feb06
6	00035	ETS	3115	Double Ridged Guide Horn	24Mar04	24Mar06
7	00161/00166	Waveline	899/801-KF	Standard Gain Horn	na	na
8	00051	HP	8566B	Spectrum Analyzer RF Section	12Apr05	12Apr06
9	00049	HP	85650A	Quasi-Peak Adapter	13Apr05	13Apr06
10	00047	HP	85685A	RF Preselector	13Apr05	13Apr06
11	00015	Agilent	4408B	Spectrum Analyzer	24Jan05	24Jan06
12	00115	Miteq	J54-00102600-35-5A	LNA	08Jun04	08Jun06
13	00093	Microtronics	HPM50111	High Pass Filter	8Jun04	8Dec05
14	00119	INMAT	18AH-10	10dB attenuator	8Jun04	8Dec05
15	00120	Celltech	n/a	Microwave Cable (RX)	25Mar05	25Mar06
16	00121	Andrew	FSJ4-50B	Microwave Cable (RX)	25Mar05	25Mar06
17	00130	Andrew	FSJ1-50A	Microwave Cable (RX)	25Mar05	25Mar06

<b>Applicant:</b>	Itronix Corporation	<b>Model:</b>	IX325A775IWLBT	<b>FCC ID:</b>	KBCIX325A775IWLBT	<b>IC ID:</b>	1943A-IX325e
<b>IX325 Rugged Tablet PC with internal Intel PRO2200BG 802.11b/g WLAN &amp; Well Green Dual Internal Antenna</b>							
2005 Celltech Labs Inc.	This document is not to be reproduced in whole or in part without the prior written permission of Celltech Labs Inc.						Page 36 of 59

### E.5. MEASUREMENT EQUIPMENT SETUP

<b>MEASUREMENT EQUIPMENT CONNECTIONS</b>	The measurement equipment was connected as shown in the F.6. A number of antennas were used to cover the applicable frequency range test. The ranges in which each antenna was used are as follows:			
	Frequency Range	Spectrum Analyzer Asset #	LNA/Filter/Attenuator Asset #	Antenna Asset #
	10kHz - 30 MHz	00051/00049/00047	none	00085
	30 MHz – 1 GHz	00051/00049/00047	none	00050
	1 GHz – 2 GHz	00051/00047	00119/00115	00035
	1 GHz – 18 GHz	00051	00093/00115	00035
	18 GHz – 22 GHz	00051	00093/00115	00161/00166
	22 GHz – 26 GHz	00015	00093/00115	00161/00166
<b>MEASUREMENT EQUIPMENT SETTINGS</b>	The spectrum analyzer was set to the following settings:			
	Frequency Range	RBW	VBW	Detector
	MHz	kHz	kHz	
	0.009 – 0.150	0.200	10	Peak*
	0.150 – 30	9	30	Peak*
	30 – 1000	100	300	Peak*
	> 1000	1000*	1000	Peak*
	*As a worst-case measurement, the average/QP limit was applied to measurements made with a peak detector, unless otherwise noted.			

### E.6. SETUP DRAWING

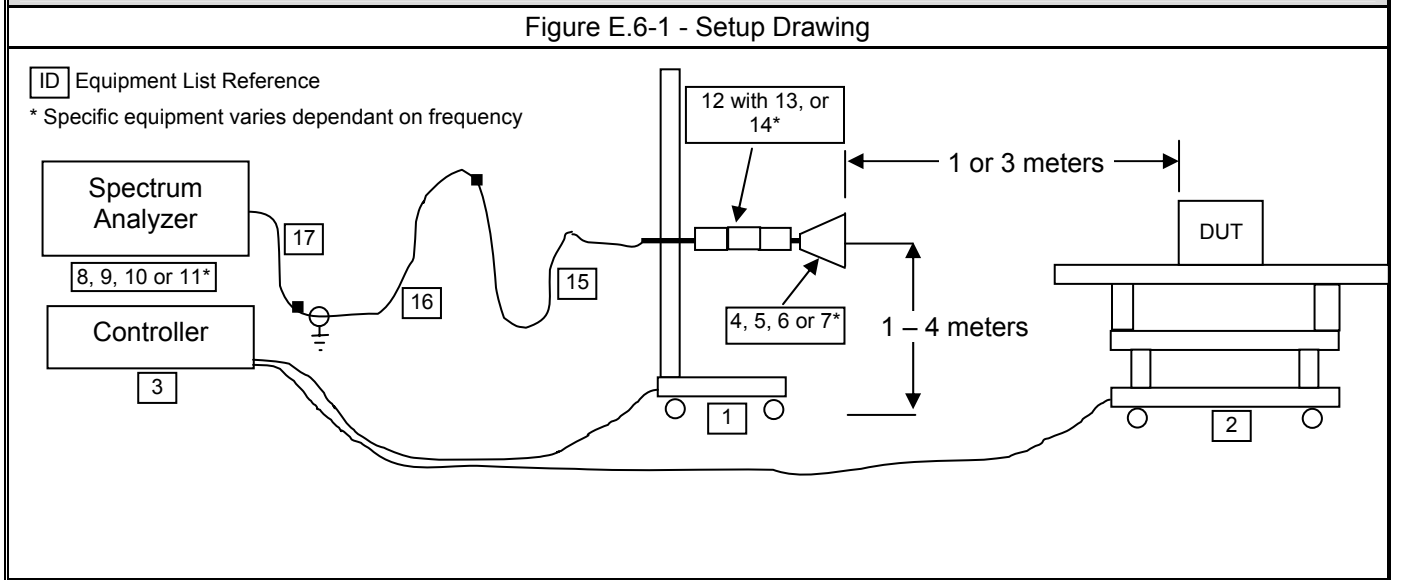



<b>Test Report Serial No.:</b>	060605KBC-T646-E15W	<b>Report Revision No.:</b>	Rev. 0
<b>Test Date(s):</b>	4Jul05 - 20Jul05	<b>Report Issue Date:</b>	8Dec05
<b>Test Standard(s):</b>	FCC 47 CFR §15.247	Industry Canada RSS-210 Issue 5	
<b>Lab Registration(s):</b>	FCC Lab Reg. # 714830	Industry Canada Lab File #3874	

### E.7. SETUP PHOTOGRAPHS

Photograph E-1 - Loop Antenna (10kHz - 30 MHz) @ 3m



Photograph E-2 - Bilog Antenna (30 MHz - 1 GHz) @ 3m



Photograph E-3 - 3115 Horn (1G - 2G) @ 3 m



Photograph E-4 - 3115 Horn with LNA/Filter @ 1m



Photograph E-5 - Waveline Horn with LNA @ 1m



Left Intentionally Blank

<b>Applicant:</b>	Itronix Corporation	<b>Model:</b>	IX325A775IWLBT	<b>FCC ID:</b>	KBCIX325A775IWLBT	<b>IC ID:</b>	1943A-IX325e
<b>IX325 Rugged Tablet PC with internal Intel PRO2200BG 802.11b/g WLAN &amp; Well Green Dual Internal Antenna</b>							
2005 Celltech Labs Inc.	This document is not to be reproduced in whole or in part without the prior written permission of Celltech Labs Inc.						Page 38 of 59

	<b>Test Report Serial No.:</b>	060605KBC-T646-E15W	<b>Report Revision No.:</b>	Rev. 0
	<b>Test Date(s):</b>	4Jul05 - 20Jul05	<b>Report Issue Date:</b>	8Dec05
	<b>Test Standard(s):</b>	FCC 47 CFR §15.247	<b>Industry Canada RSS-210 Issue 5</b>	
	<b>Lab Registration(s):</b>	FCC Lab Reg. # 714830	<b>Industry Canada Lab File #3874</b>	

### E.8. DUT OPERATING DESCRIPTION

The worst-case data rate was determined from prescan investigations. Measurements were made at three channels throughout the band, Low Channel (2412 MHz), Mid Channel (2437 MHz), High Channel (2462 MHz) and both Modes b and g.

### E.9. TEST RESULTS

#### E.9.1. Mode b - Lower Band-edge Emission Field Strengths @ Specified Distance

Channel 1 Mode b - Conducted Peak Band-edge Plots

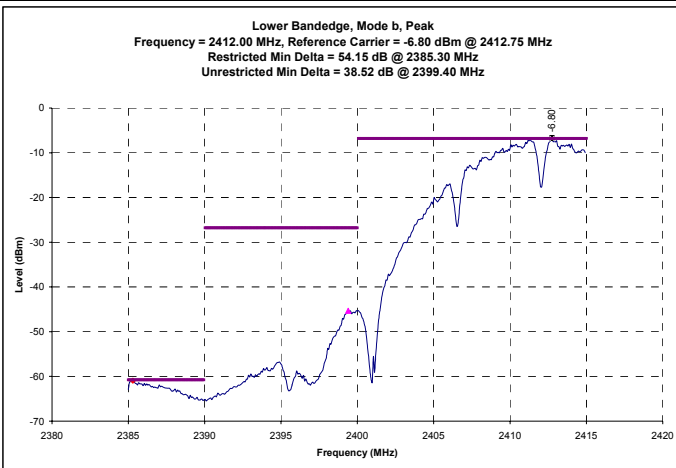

Channel 1 Mode b - Conducted Average Band-edge Plots

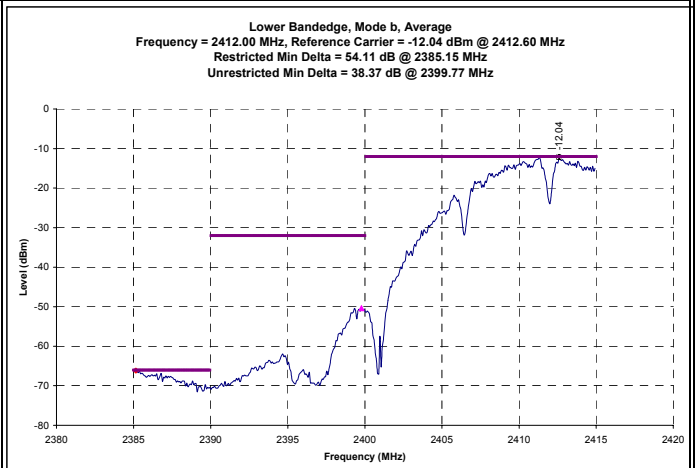

#### Channel 1 b - Calculated Band-edge (Restricted) Field Strengths

IX325 with Intel WLAN Mode b with Setting 27.0, Tx = 1 Mbps

Channel	Polarity	Distance	Frequency	Carrier Radiated Field Strength	Delta Marker	Detector	Calculated Bandedge Field Strength	Duty Cycle Correction	Corrected Bandedge Field Strength	Specifield Limit	Specified Limit Distance	Limit Distance Correction	Calculated Limit	Margin	Pass/Fail
WLAN-CH1	H	3	2385.30	93.33	54.15	PK	39.18	0.00	39.18	73.98	3.00	0.00	73.98	34.80	PASS
WLAN-CH1	H	3	2385.15	89.13	54.11	AV	35.02	0.00	35.02	53.98	3.00	0.00	53.98	18.96	PASS
WLAN-CH1	V	3	2385.30	96.03	54.15	PK	41.88	0.00	41.88	73.98	3.00	0.00	73.98	32.10	PASS
WLAN-CH1	V	3	2385.15	91.53	54.11	AV	37.42	0.00	37.42	53.98	3.00	0.00	53.98	16.56	PASS

Formulae:

Calculated Bandedge Field Strength (dBuV/m) = Carrier Radiated Field Strength (dBuV/m) + Delta Marker (dB)

Duty Cycle Correction (dB) = 20 \* log (time on / total time)

Corrected Bandedge Field Strength (dBuV/m) = Calculated Bandedge Field Strength (dBuV/m) + Duty Cycle Correction (dB)

Limit Distance Correction = 20 \* log (measurement distance / limit distance)

Calculated Limit (dBuV/m) = Specified Limit (dBuV/m) + Limit Distance Correction (dB)

Margin (dB) = Corrected Limit (dBuV/m) - Corrected Bandedge Field Strength (dBuV/m)

**Note: Measurements and calculation reference the Marker-Delta Method described in FCC Public Notice DA 00-705**

<b>Applicant:</b>	Itronix Corporation	<b>Model:</b>	IX325A775IWLBT	<b>FCC ID:</b>	KBCIX325A775IWLBT	<b>IC ID:</b>	1943A-IX325e
<b>IX325 Rugged Tablet PC with internal Intel PRO2200BG 802.11b/g WLAN &amp; Well Green Dual Internal Antenna</b>							
2005 Celltech Labs Inc.	This document is not to be reproduced in whole or in part without the prior written permission of Celltech Labs Inc.						Page 39 of 59

E.9.2. Mode b - Upper Band-edge Emission Field Strengths @ Specified Distance

Channel 11 Mode b - Conducted Peak Band-edge Plots

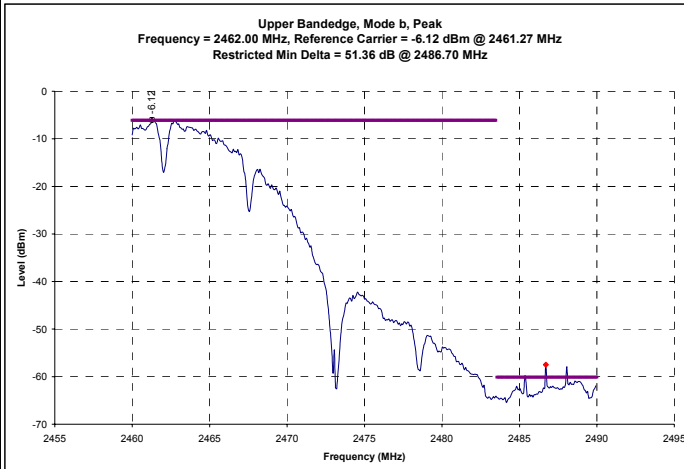

Channel 11 Mode b - Conducted Average Band-edge Plots

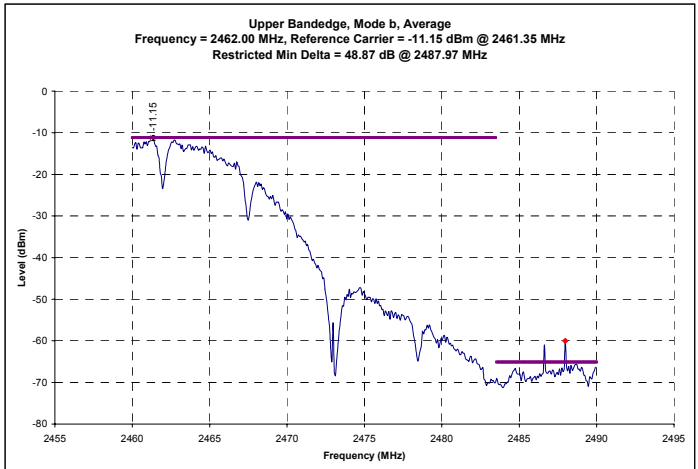

Channel 11 b - Calculated Band-edge (Restricted) Field Strengths

IX325 with Intel WLAN Mode b with Setting 27.0, Tx = 1 Mbps

Channel	Polarity	Distance	Frequency	Carrier Radiated Field Strength	Delta Marker	Detector	Calculated Bandedge Field Strength	Duty Cycle Correction	Corrected Bandedge Field Strength	Specified Limit	Specified Limit Distance	Limit Distance Correction	Calculated Limit	Margin	Pass/Fail
WLAN-CH11	H	3	2486.70	93.98	51.36	PK	42.62	0.00	42.62	73.98	3.00	0.00	73.98	31.36	PASS
WLAN-CH11	H	3	2487.97	89.73	48.87	AV	40.86	0.00	40.86	53.98	3.00	0.00	53.98	13.12	PASS
WLAN-CH11	V	3	2486.70	97.58	51.36	PK	46.22	0.00	46.22	73.98	3.00	0.00	73.98	27.76	PASS
WLAN-CH11	V	3	2487.97	93.13	48.87	AV	44.26	0.00	44.26	53.98	3.00	0.00	53.98	9.72	PASS

Formulae:

Calculated Bandedge Field Strength (dBuV/m) = Carrier Radiated Field Strength (dBuV/m) + Delta Marker (dB)

Duty Cycle Correction (dB) = 20 \* log (time on / total time)

Corrected Bandedge Field Strength (dBuV/m) = Calculated Bandedge Field Strength (dBuV/m) + Duty Cycle Correction (dB)

Limit Distance Correction = 20 \* log (measurement distance / limit distance)

Calculated Limit (dBuV/m) = Specified Limit (dBuV/m) + Limit Distance Correction (dB)

Margin (dB) = Corrected Limit (dBuV/m) - Corrected Bandedge Field Strength (dBuV/m)

**Note: Measurements and calculation reference the Marker-Delta Method described in FCC Public Notice DA 00-705**

 Testing and Engineering Services Lab	<b>Test Report Serial No.:</b>	060605KBC-T646-E15W	<b>Report Revision No.:</b>	Rev. 0
	<b>Test Date(s):</b>	4Jul05 - 20Jul05	<b>Report Issue Date:</b>	8Dec05
	<b>Test Standard(s):</b>	FCC 47 CFR §15.247	<b>Industry Canada RSS-210 Issue 5</b>	
	<b>Lab Registration(s):</b>	FCC Lab Reg. # 714830	<b>Industry Canada Lab File #3874</b>	

E.9.3. Mode b - Channel 1 Out-of-Band Spurious Emission Field Strengths @ Specified Distance (within restricted bands)

 Testing and Engineering Services Lab	<b>Project Number:</b>	060605KBC-T643-E15W	<b>Standard:</b>	FCC15.247c
	<b>Company:</b>	Itronix	<b>Test Start Date:</b>	4-Jul-05
	<b>Product:</b>	IX325 with Intel PRO 2200BG	<b>Test End Date:</b>	13-Jul-05

Channel	Polarity	Distance m	Rx Antenna	Frequency MHz	SA Level dBuV	Noise Floor	Rx AF	Rx CL	Other Rx	Total Rx CF	Field Strength	Detector	Limit Distance	Limit Distance Correction	Calculated Limit	Margin	Pass/Fail
							dB/m	dB	dB	dB/m	dBuV/m	(PK/QP/AV)	m	dB	dBuV/m	dB	
WLAN-CH1	H	3	Bilog SN1607	129.04	13.00		12.16	1.14	0.00	13.30	26.30	PK*	3.00	0.00	43.52	17.22	PASS
WLAN-CH1	H	3	Horn SN6276	1590.00	16.70	x	27.63	4.14	0.00	31.77	48.47	PK*	3.00	0.00	53.98	5.51	PASS
WLAN-CH1	H	3	Horn SN6276	2274.96	34.00	x	30.04	4.94	-23.14	11.84	45.84	PK*	3.00	0.00	53.98	8.14	PASS
WLAN-CH1	H	3	Horn SN6276	<b>4824.00</b>	29.20	x	35.35	7.40	-31.04	11.71	40.91	PK*	3.00	0.00	53.98	13.07	PASS
WLAN-CH1	H	3	Horn SN6276	9376.41	35.40	x	40.28	11.52	-30.72	21.08	56.48	PK	3.00	0.00	73.98	17.50	PASS
WLAN-CH1	H	3	Horn SN6276	9376.41	21.90	x	40.28	11.52	-30.72	21.08	42.98	AV	3.00	0.00	53.98	11.00	PASS
WLAN-CH1	H	1	Horn SN6276	11572.20	39.05	x	40.41	8.40	-30.63	18.18	57.23	PK*	3.00	9.54	63.52	6.29	PASS
WLAN-CH1	H	1	Horn SN6276	<b>12054.80</b>	38.25	x	40.58	8.62	-30.61	18.58	56.83	PK*	3.00	9.54	63.52	6.69	PASS
WLAN-CH1	H	1	Horn SN6276	12586.35	39.39	x	41.27	8.86	-30.59	19.54	58.93	PK*	3.00	9.54	63.52	4.59	PASS
WLAN-CH1	H	1	Horn SN6276	16074.85	39.74	x	40.79	10.46	-31.63	19.62	59.36	PK*	3.00	9.54	63.52	4.16	PASS
WLAN-CH1	H	1	Horn SN6276	17953.05	40.02	x	45.76	11.15	-32.63	24.28	64.30	PK	3.00	9.54	83.52	19.22	PASS
WLAN-CH1	H	1	Horn SN6276	17953.05	34.49	x	45.76	11.15	-32.63	24.28	58.77	AV	3.00	9.54	63.52	4.75	PASS
WLAN-CH1	H	1	Waveline 899	18259.03	39.60		40.20	11.26	-34.68	16.78	56.38	PK*	3.00	9.54	63.52	7.14	PASS
WLAN-CH1	H	1	Waveline 899	<b>19296.00</b>	38.58		40.26	11.64	-35.23	16.67	55.25	PK*	3.00	9.54	63.52	8.27	PASS
WLAN-CH1	H	1	Waveline 899	21182.23	40.68		40.30	12.33	-35.59	17.05	57.73	PK*	3.00	9.54	63.52	5.80	PASS
WLAN-CH1	V	3	Horn SN6276	1137.91	15.30	x	26.69	3.49	0.00	30.19	45.49	PK*	3.00	0.00	53.98	8.49	PASS
WLAN-CH1	V	3	Horn SN6276	1591.34	16.10	x	27.64	4.14	0.00	31.78	47.88	PK*	3.00	0.00	53.98	6.10	PASS
WLAN-CH1	V	3	Horn SN6276	2241.88	34.10	x	29.99	4.96	-23.14	11.81	45.91	PK*	3.00	0.00	53.98	8.07	PASS
WLAN-CH1	V	3	Horn SN6276	2277.80	33.60	x	30.04	4.94	-23.14	11.85	45.45	PK*	3.00	0.00	53.98	8.53	PASS
WLAN-CH1	V	3	Horn SN6276	2495.00	34.30		30.39	5.23	-23.12	12.50	46.80	PK*	3.00	0.00	53.98	7.18	PASS
WLAN-CH1	V	3	Horn SN6276	3814.62	30.90	x	34.18	6.53	-31.12	9.59	40.49	PK*	3.00	0.00	53.98	13.49	PASS
WLAN-CH1	V	3	Horn SN6276	4101.79	32.10	x	34.70	6.79	-31.10	10.39	42.49	PK*	3.00	0.00	53.98	11.49	PASS
WLAN-CH1	V	3	Horn SN6276	4532.79	31.10	x	34.77	7.17	-31.06	10.87	41.97	PK*	3.00	0.00	53.98	12.00	PASS
WLAN-CH1	V	3	Horn SN6276	<b>4824.00</b>	29.60	x	35.35	7.40	-31.04	11.71	41.31	PK*	3.00	0.00	53.98	12.67	PASS
WLAN-CH1	V	1	Horn SN6276	11495.45	39.13	x	40.40	8.36	-30.63	18.13	57.26	PK*	3.00	9.54	63.52	6.26	PASS
WLAN-CH1	V	1	Horn SN6276	<b>12069.45</b>	38.79		40.60	8.62	-30.61	18.61	57.40	PK*	3.00	9.54	63.52	6.12	PASS
WLAN-CH1	V	1	Horn SN6276	15747.35	39.47	x	40.70	10.32	-31.46	19.56	59.03	PK*	3.00	9.54	63.52	4.49	PASS
WLAN-CH1	V	1	Waveline 899	18070.05	38.98		40.20	11.19	-34.58	16.81	55.79	PK*	3.00	9.54	63.52	7.73	PASS
WLAN-CH1	V	1	Waveline 899	<b>19296.00</b>	36.96		40.26	11.64	-35.23	16.67	53.63	PK*	3.00	9.54	63.52	9.89	PASS
WLAN-CH1	V	1	Waveline 899	23817.08	40.39		40.40	13.30	-35.55	18.14	58.53	PK*	3.00	9.54	63.52	4.99	PASS

**Notes:**  
 \*PK denotes QP or Average limits applied to emissions measured with a peak detector  
**BOLD** signifies the highest signal measured near a carrier harmonic frequency  
 No EUT emissions levels were measured above those reported  
**Formulae:**  
 Total CF = Antenna Factor + Cable Factor + Other Factor (Amplifier Gain, filter loss, etc)  
 Field Strength = SA Reading + Total CF  
 Limit Distance Correction = 40\*log(d1/d2) for F<30 MHz, 20\*log(d1/d2) for F> 30 MHz:  
 where d1 is the measurement distance, d2 is the published limit distance

**Limit = Specified Limit + Limit Distance. The frequency points reported describe the highest emission measured in each of the ranges tested and are used to describe the measured spectrum as a whole. It is shown that the highest emissions measured within the spectrum pass the appropriate restricted limits; therefore all emissions within the restricted bands would also meet the requirements. No out-of-band emissions were measured above the levels noted.**



	<b>Test Report Serial No.:</b>	060605KBC-T646-E15W	<b>Report Revision No.:</b>	Rev. 0
	<b>Test Date(s):</b>	4Jul05 - 20Jul05	<b>Report Issue Date:</b>	8Dec05
	<b>Test Standard(s):</b>	FCC 47 CFR §15.247	Industry Canada RSS-210 Issue 5	
	<b>Lab Registration(s):</b>	FCC Lab Reg. # 714830	Industry Canada Lab File #3874	

E.9.4. Mode b - Channel 6 Out-of-Band Spurious Emission Field Strengths @ Specified Distance (within restricted bands)

Channel	Polarity	Distance	Rx Antenna	Frequency	SA Level	Noise Floor	Rx AF	Rx CL	Other Rx	Total Rx CF	Field Strength	Detector	Limit Distance	Limit Distance Correction	Calculated Limit	Margin	Pass/Fail
							dB/m	dB	dB	dB/m	dBuV/m	(PK/QP/AV)	m	dB	dBuV/m	dB	
WLAN-CH6	H	3	Horn SN6276	1587.56	17.90	x	27.62	4.14	0.00	31.76	49.66	PK*	3.00	0.00	53.98	4.32	PASS
WLAN-CH6	H	3	Horn SN6276	2797.10	33.60	x	31.35	5.52	-23.09	13.78	47.38	PK*	3.00	0.00	53.98	6.60	PASS
WLAN-CH6	H	3	Horn SN6276	<b>4874.00</b>	28.90	x	35.45	7.60	-31.04	12.01	40.91	PK*	3.00	0.00	53.98	13.07	PASS
WLAN-CH6	H	3	Horn SN6276	<b>7311.00</b>	34.00	x	38.36	9.93	-30.84	17.46	51.46	PK*	3.00	0.00	53.98	2.52	PASS
WLAN-CH6	H	1	Horn SN6276	<b>12190.30</b>	38.74	x	40.77	8.68	-30.61	18.84	57.58	PK*	3.00	9.54	63.52	5.94	PASS
WLAN-CH6	H	1	Horn SN6276	17797.90	39.60	x	45.29	11.09	-32.54	23.84	63.44	PK	3.00	9.54	83.52	20.08	PASS
WLAN-CH6	H	1	Horn SN6276	17797.90	29.70	x	45.29	11.09	-32.54	23.84	53.54	AV	3.00	9.54	63.52	9.98	PASS
WLAN-CH6	H	1	Waveline 899	18169.50	39.41	x	40.20	11.23	-34.63	16.80	56.21	PK*	3.00	9.54	63.52	7.31	PASS
WLAN-CH6	H	1	Waveline 899	<b>19496.00</b>	37.69	x	40.30	11.71	-35.33	16.68	54.37	PK*	3.00	9.54	63.52	9.15	PASS
WLAN-CH6	H	1	Waveline 899	23945.08	40.33	x	40.40	13.35	-35.55	18.19	58.52	PK*	3.00	9.54	63.52	5.00	PASS
WLAN-CH6	V	3	Horn SN6276	1058.00	17.20	x	26.58	3.35	0.00	29.93	47.13	PK*	3.00	0.00	53.98	6.85	PASS
WLAN-CH6	V	3	Horn SN6276	1109.65	19.70	x	26.65	3.43	0.00	30.08	49.78	PK*	3.00	0.00	53.98	4.20	PASS
WLAN-CH6	V	3	Horn SN6276	1587.03	15.70	x	27.62	4.14	0.00	31.76	47.46	PK*	3.00	0.00	53.98	6.52	PASS
WLAN-CH6	V	3	Horn SN6276	2317.35	36.60	x	30.11	4.99	-23.13	11.96	48.56	PK*	3.00	0.00	53.98	5.42	PASS
WLAN-CH6	V	3	Horn SN6276	3801.48	31.00	x	34.14	6.51	-31.12	9.53	40.53	PK*	3.00	0.00	53.98	13.45	PASS
WLAN-CH6	V	3	Horn SN6276	4029.12	31.00	x	34.70	6.70	-31.10	10.30	41.30	PK*	3.00	0.00	53.98	12.68	PASS
WLAN-CH6	V	3	Horn SN6276	<b>4874.00</b>	30.50	x	35.45	7.60	-31.04	12.01	42.51	PK*	3.00	0.00	53.98	11.47	PASS
WLAN-CH6	V	3	Horn SN6276	<b>7311.00</b>	34.60	x	38.36	9.93	-30.84	17.46	52.06	PK*	3.00	0.00	53.98	1.92	PASS
WLAN-CH6	V	1	Horn SN6276	<b>12185.00</b>	37.78	x	40.76	8.68	-30.61	18.83	56.61	PK*	3.00	9.54	63.52	6.91	PASS
WLAN-CH6	V	1	Horn SN6276	17739.40	40.07	x	45.12	11.07	-32.51	23.68	63.75	PK	3.00	9.54	83.52	19.78	PASS
WLAN-CH6	V	1	Horn SN6276	17739.40	29.39	x	45.12	11.07	-32.51	23.68	53.07	AV	3.00	9.54	63.52	10.46	PASS
WLAN-CH6	V	1	Horn SN6276	17910.10	39.56	x	45.63	11.13	-32.60	24.16	63.72	PK	3.00	9.54	83.52	19.80	PASS
WLAN-CH6	V	1	Horn SN6276	17910.10	29.61	x	45.63	11.13	-32.60	24.16	53.77	AV	3.00	9.54	63.52	9.75	PASS
WLAN-CH6	V	1	Waveline 899	18616.33	39.00	x	40.20	11.39	-34.87	16.72	55.72	PK*	3.00	9.54	63.52	7.80	PASS
WLAN-CH6	V	1	Waveline 899	<b>19496.00</b>	37.32	x	40.30	11.71	-35.33	16.68	54.00	PK*	3.00	9.54	63.52	9.52	PASS
WLAN-CH6	V	1	Waveline 899	23955.20	40.10	x	40.40	13.35	-35.55	18.20	58.30	PK*	3.00	9.54	63.52	5.23	PASS

Notes:

\*PK denotes QP or Average limits applied to emissions measured with a peak detector  
**BOLD** signifies the highest signal measured near a carrier harmonic frequency  
 No EUT emissions levels were measured above those reported

Formulae:

Total CF = Antenna Factor + Cable Factor + Other Factor (Amplifier Gain, filter loss, etc)  
 Field Strength = SA Reading + Total CF  
 Limit Distance Correction = 40\*log(d1/d2) for F<30 MHz, 20\*log(d1/d2) for F> 30 MHz:  
 where d1 is the measurement distance, d2 is the published limit distance

**Limit = Specified Limit + Limit Distance. The frequency points reported describe the highest emission measured in each of the ranges tested and are used to describe the measured spectrum as a whole. It is shown that the highest emissions measured within the spectrum pass the appropriate restricted limits; therefore all emissions within the restricted bands would also meet the requirements. No out-of-band emissions were measured above the levels noted.**

<b>Applicant:</b>	Itronix Corporation	<b>Model:</b>	IX325A775IWLBT	<b>FCC ID:</b>	KBCIX325A775IWLBT	<b>IC ID:</b>	1943A-IX325e
<b>IX325 Rugged Tablet PC with internal Intel PRO2200BG 802.11b/g WLAN &amp; Well Green Dual Internal Antenna</b>							
2005 Celltech Labs Inc.	This document is not to be reproduced in whole or in part without the prior written permission of Celltech Labs Inc.						Page 42 of 59

	<b>Test Report Serial No.:</b>	060605KBC-T646-E15W	<b>Report Revision No.:</b>	Rev. 0
	<b>Test Date(s):</b>	4Jul05 - 20Jul05	<b>Report Issue Date:</b>	8Dec05
	<b>Test Standard(s):</b>	FCC 47 CFR §15.247	<b>Industry Canada RSS-210 Issue 5</b>	
	<b>Lab Registration(s):</b>	FCC Lab Reg. # 714830	<b>Industry Canada Lab File #3874</b>	

E.9.5. Mode b - Channel 11 Out-of-Band Spurious Emission Field Strengths @ Specified Distance (within restricted bands)

Channel	Polarity	Distance m	Rx Antenna	Frequency MHz	SA Level dBuV	Noise Floor	Rx AF	Rx CL	Other Rx	Total Rx CF	Field Strength	Detector	Limit Distance	Limit Distance Correction	Calculated Limit	Margin	Pass/Fail
							dB/m	dB	dB	dB/m	dBuV/m	(PK/QP/AV)	m	dB	dBuV/m	dB	
WLAN-CH11	H	3	Horn SN6276	1049.19	16.40	x	26.57	3.34	0.00	29.90	46.30	PK*	3.00	0.00	53.98	7.67	PASS
WLAN-CH11	H	3	Horn SN6276	1587.59	15.70	x	27.62	4.14	0.00	31.76	47.46	PK*	3.00	0.00	53.98	6.52	PASS
WLAN-CH11	H	3	Horn SN6276	2893.42	32.80	x	31.66	5.63	-23.09	14.20	47.00	PK*	3.00	0.00	53.98	6.98	PASS
WLAN-CH11	H	3	Horn SN6276	4284.12	33.90		34.70	6.94	-31.08	10.56	44.46	PK*	3.00	0.00	53.98	9.52	PASS
WLAN-CH11	H	3	Horn SN6276	4924.00	30.10	x	35.55	7.53	-31.03	12.05	42.15	PK*	3.00	0.00	53.98	11.83	PASS
WLAN-CH11	H	3	Horn SN6276	7386.00	33.70	x	38.49	9.94	-30.83	17.61	51.31	PK*	3.00	0.00	53.98	2.67	PASS
WLAN-CH11	H	1	Horn SN6276	12310.00	36.79	x	40.93	8.74	-30.60	19.07	55.86	PK*	3.00	9.54	63.52	7.66	PASS
WLAN-CH11	H	1	Horn SN6276	17918.85	40.10	x	45.66	11.14	-32.61	24.18	64.28	PK	3.00	9.54	83.52	19.24	PASS
WLAN-CH11	H	1	Horn SN6276	17918.85	29.36	x	45.66	11.14	-32.61	24.18	53.54	AV	3.00	9.54	63.52	9.98	PASS
WLAN-CH11	H	1	Waveline_899	18230.68	39.24	x	40.20	11.25	-34.66	16.79	56.03	PK*	3.00	9.54	63.52	7.49	PASS
WLAN-CH11	H	1	Waveline_899	19696.00	38.81	x	40.30	11.79	-35.44	16.65	55.46	PK*	3.00	9.54	63.52	8.06	PASS
WLAN-CH11	H	1	Waveline_899	20102.65	40.03	x	40.30	11.94	-35.60	16.64	56.67	PK*	3.00	9.54	63.52	6.85	PASS
WLAN-CH11	H	1	Waveline_899	20997.08	39.78	x	40.30	12.26	-35.59	16.98	56.76	PK*	3.00	9.54	63.52	6.77	PASS
WLAN-CH11	H	1	Waveline_899	22158.00	38.56	x	40.33	12.69	-35.57	17.45	56.01	PK*	3.00	9.54	63.52	7.51	PASS
WLAN-CH11	H	1	Waveline_899	22246.03	39.78	x	40.35	12.72	-35.57	17.50	57.28	PK*	3.00	9.54	63.52	6.24	PASS
WLAN-CH11	H	1	Waveline_899	23962.35	40.76	x	40.40	13.35	-35.55	18.20	58.96	PK*	3.00	9.54	63.52	4.56	PASS
WLAN-CH11	V	3	Horn SN6276	1089.79	19.20		26.63	3.39	0.00	30.01	49.21	PK*	3.00	0.00	53.98	4.77	PASS
WLAN-CH11	V	3	Horn SN6276	1109.61	26.10		26.65	3.43	0.00	30.08	56.18	PK	3.00	0.00	73.98	17.80	PASS
WLAN-CH11	V	3	Horn SN6276	1109.61	2.50		26.65	3.43	0.00	30.08	32.58	AV	3.00	0.00	53.98	21.40	PASS
WLAN-CH11	V	3	Horn SN6276	1130.13	18.30		26.68	3.47	0.00	30.15	48.45	PK*	3.00	0.00	53.98	5.53	PASS
WLAN-CH11	V	3	Horn SN6276	1512.91	16.10	x	27.26	4.02	0.00	31.28	47.38	PK*	3.00	0.00	53.98	6.60	PASS
WLAN-CH11	V	3	Horn SN6276	2317.33	36.00		30.11	4.99	-23.13	11.96	47.96	PK*	3.00	0.00	53.98	6.02	PASS
WLAN-CH11	V	3	Horn SN6276	2795.09	36.40		31.34	5.53	-23.10	13.77	50.17	PK*	3.00	0.00	53.98	3.80	PASS
WLAN-CH11	V	3	Horn SN6276	4924.00	31.00		35.55	7.53	-31.03	12.05	43.05	PK*	3.00	0.00	53.98	10.93	PASS
WLAN-CH11	V	3	Horn SN6276	7386.00	34.60	x	38.49	9.94	-30.83	17.61	52.21	PK*	3.00	0.00	53.98	1.77	PASS
WLAN-CH11	V	1	Horn SN6276	11643.40	38.32	x	40.43	8.43	-30.63	18.23	56.55	PK*	3.00	9.54	63.52	6.97	PASS
WLAN-CH11	V	1	Horn SN6276	12310.00	36.00	x	40.93	8.74	-30.60	19.07	55.07	PK*	3.00	9.54	63.52	8.45	PASS
WLAN-CH11	V	1	Horn SN6276	16180.80	39.65	x	41.02	10.49	-31.68	19.83	59.48	PK*	3.00	9.54	63.52	4.04	PASS
WLAN-CH11	V	1	Horn SN6276	17978.15	39.69	x	45.83	11.16	-32.64	24.35	64.04	PK	3.00	9.54	83.52	19.48	PASS
WLAN-CH11	V	1	Horn SN6276	17978.15	29.64	x	45.83	11.16	-32.64	24.35	53.99	AV	3.00	9.54	63.52	9.53	PASS
WLAN-CH11	V	1	Waveline_899	18335.93	39.67	x	40.20	11.29	-34.72	16.77	56.44	PK*	3.00	9.54	63.52	7.08	PASS
WLAN-CH11	V	1	Waveline_899	19696.00	37.48	x	40.30	11.79	-35.44	16.65	54.13	PK*	3.00	9.54	63.52	9.39	PASS
WLAN-CH11	V	1	Waveline_899	20534.48	40.41	x	40.30	12.09	-35.59	16.80	57.21	PK*	3.00	9.54	63.52	6.31	PASS
WLAN-CH11	V	1	Waveline_899	21199.00	40.29	x	40.30	12.34	-35.59	17.05	57.34	PK*	3.00	9.54	63.52	6.18	PASS
WLAN-CH11	V	1	Waveline_899	22082.15	39.87	x	40.32	12.66	-35.58	17.40	57.27	PK*	3.00	9.54	63.52	6.25	PASS
WLAN-CH11	V	1	Waveline_899	22158.00	37.41	x	40.33	12.69	-35.57	17.45	54.86	PK*	3.00	9.54	63.52	8.66	PASS
WLAN-CH11	V	1	Waveline_899	22951.08	39.60	x	40.40	12.98	-35.57	17.82	57.42	PK*	3.00	9.54	63.52	6.11	PASS
WLAN-CH11	V	1	Waveline_899	23951.40	40.91		40.40	13.35	-35.55	18.19	59.10	PK*	3.00	9.54	63.52	4.42	PASS

**Notes:**

\*PK denotes QP or Average limits applied to emissions measured with a peak detector

**BOLD** signifies the highest signal measured near a carrier harmonic frequency

No EUT emissions levels were measured above those reported

**Formulae:**

Total CF = Antenna Factor + Cable Factor + Other Factor (Amplifier Gain, filter loss, etc)

Field Strength = SA Reading + Total CF

Limit Distance Correction = 40\*log(d1/d2) for F<30 MHz, 20\*log(d1/d2) for F> 30 MHz:

where d1 is the measurement distance, d2 is the published limit distance

**Limit = Specified Limit + Limit Distance. The frequency points reported describe the highest emission measured in each of the ranges tested and are used to describe the measured spectrum as a whole. It is shown that the highest emissions measured within the spectrum pass the appropriate restricted limits; therefore all emissions within the restricted bands would also meet the requirements. No out-of-band emissions were measured above the levels noted.**

<b>Applicant:</b>	Itronix Corporation	<b>Model:</b>	IX325A775IWLBT	<b>FCC ID:</b>	KBCIX325A775IWLBT	<b>IC ID:</b>	1943A-IX325e
<b>IX325 Rugged Tablet PC with internal Intel PRO2200BG 802.11b/g WLAN &amp; Well Green Dual Internal Antenna</b>							
2005 Celltech Labs Inc.	This document is not to be reproduced in whole or in part without the prior written permission of Celltech Labs Inc.						Page 43 of 59

<b>Test Report Serial No.:</b>	060605KBC-T646-E15W	<b>Report Revision No.:</b>	Rev. 0
<b>Test Date(s):</b>	4Jul05 - 20Jul05	<b>Report Issue Date:</b>	8Dec05
<b>Test Standard(s):</b>	FCC 47 CFR §15.247	Industry Canada RSS-210 Issue 5	
<b>Lab Registration(s):</b>	FCC Lab Reg. # 714830	Industry Canada Lab File #3874	

E.9.6. Mode g - Lower Band-edge Emission Field Strengths @ Specified Distance

Channel 1 Mode g - Conducted Peak Band-edge Plots

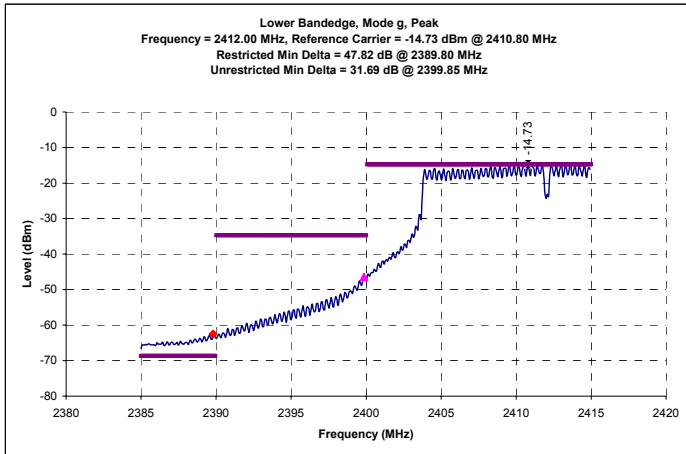

Channel 1 Mode g - Conducted Average Band-edge Plots

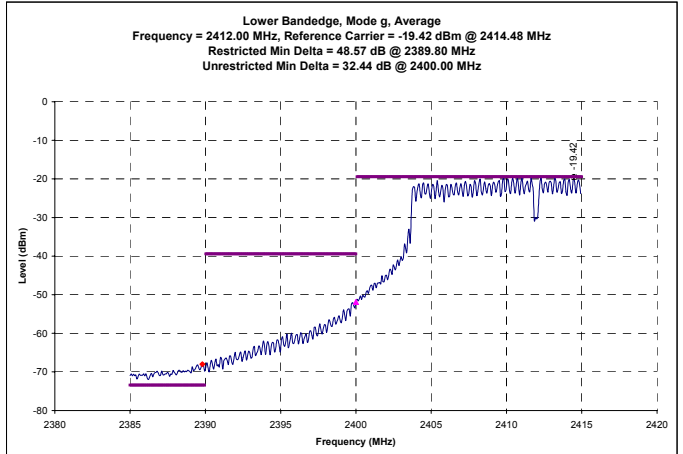

Channel 1 g - Calculated Band-edge (Restricted) Field Strengths

IX325 with Intel WLAN Mode g with Setting 20, Tx = 6 Mbps

Channel	Polarity	Distance	Frequency	Carrier Radiated Field Strength	Delta Marker	Detector	Calculated Bandedge Field Strength	Duty Cycle Correction	Corrected Bandedge Field Strength	Specified Limit	Specified Limit Distance	Limit Distance Correction	Calculated Limit	Margin	Pass/Fail
WLAN-CH1	H	3	2389.80	92.83	47.82	PK	45.01	0.00	45.01	73.98	3.00	0.00	73.98	28.97	PASS
WLAN-CH1	H	3	2389.80	80.33	48.57	AV	31.76	0.00	31.76	53.98	3.00	0.00	53.98	22.22	PASS
WLAN-CH1	V	3	2389.80	91.63	47.82	PK	43.81	0.00	43.81	73.98	3.00	0.00	73.98	30.17	PASS
WLAN-CH1	V	3	2389.80	78.48	48.57	AV	29.91	0.00	29.91	53.98	3.00	0.00	53.98	24.07	PASS

Formulae:

- Calculated Bandedge Field Strength (dBuV/m) = Carrier Radiated Field Strength (dBuV/m) + Delta Marker (dB)
- Duty Cycle Correction (dB) = 20 \* log (time on / total time)
- Corrected Bandedge Field Strength (dBuV/m) = Calculated Bandedge Field Strength (dBuV/m) + Duty Cycle Correction (dB)
- Limit Distance Correction = 20 \* log (measurement distance / limit distance )
- Calculated Limit (dBuV/m) = Specified Limit (dBuV/m) + Limit Distance Correction (dB)
- Margin (dB) = Corrected Limit (dBuV/m) – Corrected Bandedge Field Strength (dBuV/m)

**Note: Measurements and calculation reference the Marker-Delta Method described in FCC Public Notice DA 00-705**

<b>Applicant:</b>	Itronix Corporation	<b>Model:</b>	IX325A775IWLBT	<b>FCC ID:</b>	KBCIX325A775IWLBT	<b>IC ID:</b>	1943A-IX325e
<b>IX325 Rugged Tablet PC with internal Intel PRO2200BG 802.11b/g WLAN &amp; Well Green Dual Internal Antenna</b>							
2005 Celltech Labs Inc.	This document is not to be reproduced in whole or in part without the prior written permission of Celltech Labs Inc.						Page 44 of 59



E.9.7. Mode g - Upper Band-edge Emission Field Strengths @ Specified Distance

Channel 11 Mode g - Conducted Peak Band-edge Plots

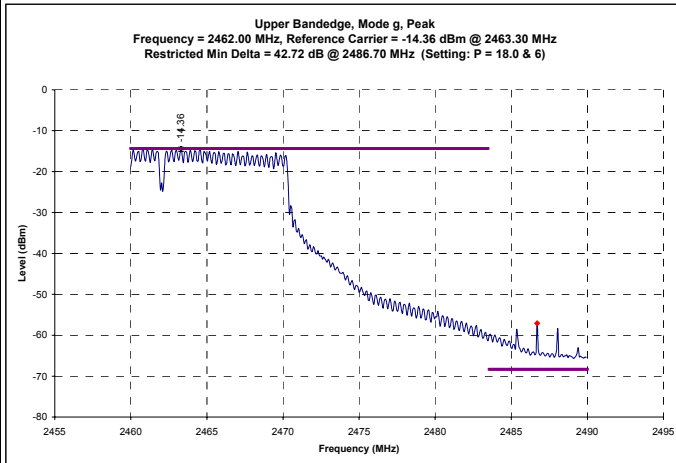

Channel 11 Mode g - Conducted Average Band-edge Plots

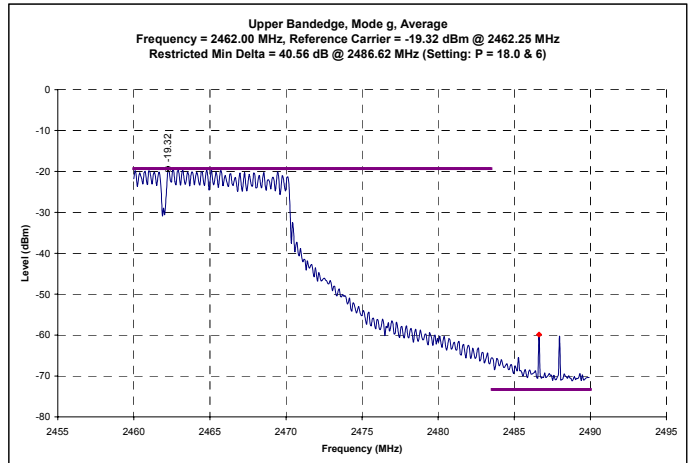

Channel 11 g - Calculated Band-edge (Restricted) Field Strengths

IX325 with Intel WLAN Mode g with Setting 20, Tx = 6 Mbps

Channel	Polarity	Distance	Frequency	Carrier Radiated Field Strength	Delta Marker	Detector	Calculated Bandedge Field Strength	Duty Cycle Correction	Corrected Bandedge Field Strength	Specified Limit	Specified Limit Distance	Limit Distance Correction	Calculated Limit	Margin	Pass/Fail
WLAN-CH11	H	3	2486.70	95.18	42.72	PK	52.46	0.00	52.46	73.98	3.00	0.00	73.98	21.52	PASS
WLAN-CH11	H	3	2486.62	82.53	40.56	AV	41.97	0.00	41.97	53.98	3.00	0.00	53.98	12.01	PASS
WLAN-CH11	V	3	2486.70	92.98	42.72	PK	50.26	0.00	50.26	73.98	3.00	0.00	73.98	23.72	PASS
WLAN-CH11	V	3	2486.62	80.43	40.56	AV	39.87	0.00	39.87	53.98	3.00	0.00	53.98	14.11	PASS

Formulae:

- Calculated Bandedge Field Strength (dBuV/m) = Carrier Radiated Field Strength (dBuV/m) + Delta Marker (dB)
- Duty Cycle Correction (dB) = 20 \* log (time on / total time)
- Corrected Bandedge Field Strength (dBuV/m) = Calculated Bandedge Field Strength (dBuV/m) + Duty Cycle Correction (dB)
- Limit Distance Correction = 20 \* log (measurement distance / limit distance )
- Calculated Limit (dBuV/m) = Specified Limit (dBuV/m) + Limit Distance Correction (dB)
- Margin (dB) = Corrected Limit (dBuV/m) – Corrected Bandedge Field Strength (dBuV/m)

**Note: Measurements and calculation reference the Marker-Delta Method described in FCC Public Notice DA 00-705**

 Testing and Engineering Services Lab	<b>Test Report Serial No.:</b>	060605KBC-T646-E15W	<b>Report Revision No.:</b>	Rev. 0
	<b>Test Date(s):</b>	4Jul05 - 20Jul05	<b>Report Issue Date:</b>	8Dec05
	<b>Test Standard(s):</b>	FCC 47 CFR §15.247	Industry Canada RSS-210 Issue 5	
	<b>Lab Registration(s):</b>	FCC Lab Reg. # 714830	Industry Canada Lab File #3874	

E.9.8. Mode g - Channel 1 Out-of-Band Spurious Emission Field Strengths @ Specified Distance (within restricted bands)

Channel	Polarity	Distance m	Rx Antenna	Frequency MHz	SA Level dBuV	Noise Floor dB/m	Rx AF dB	Rx CL dB	Other Rx dB	Total Rx CF dB/m	Field Strength dBuV/m	Detector (PK/QP/AV)	Limit Distance m	Limit Distance Correction dB	Calculated Limit dBuV/m	Margin dB	Pass/Fail				
																		Project Number:	060605KBC-T643-E15W	Standard:	FCC15.209
																		Company:	Itronix	Test Start Date:	4-Jul-05
Product:	IX325 with Intel PRO 2200BG	Test End Date:	13-Jul-05																		
WLAN-CH1	H	3	Horn SN6276	1125.65	20.20	x	28.68	3.45	0.00	30.13	50.33	PK*	3.00	0.00	53.98	3.65	PASS				
WLAN-CH1	H	3	Horn SN6276	1585.44	15.80	x	27.61	4.14	0.00	31.75	47.55	PK*	3.00	0.00	53.98	6.43	PASS				
WLAN-CH1	H	3	Horn SN6276	2311.00	35.10	x	30.10	4.97	-23.13	11.94	47.04	PK*	3.00	0.00	53.98	6.94	PASS				
WLAN-CH1	H	3	Horn SN6276	4245.42	30.80	x	34.70	6.90	-31.09	10.52	41.32	PK*	3.00	0.00	53.98	12.66	PASS				
WLAN-CH1	H	3	Horn SN6276	<b>4824.00</b>	29.20	x	35.35	7.40	-31.04	11.71	40.91	PK*	3.00	0.00	53.98	13.07	PASS				
WLAN-CH1	H	1	Horn SN6276	<b>12061.65</b>	37.95	x	40.59	8.62	-30.61	18.60	56.55	PK*	3.00	9.54	63.52	6.98	PASS				
WLAN-CH1	H	1	Horn SN6276	<b>14472.00</b>	37.92	x	42.57	9.73	-30.78	21.52	59.44	PK*	3.00	9.54	63.52	4.08	PASS				
WLAN-CH1	H	1	Waveline_899	18291.08	39.30	x	40.20	11.27	-34.69	16.78	56.08	PK*	3.00	9.54	63.52	7.44	PASS				
WLAN-CH1	H	1	Waveline_899	<b>19296.00</b>	37.70	x	40.26	11.64	-35.23	16.67	54.37	PK*	3.00	9.54	63.52	9.15	PASS				
WLAN-CH1	H	1	Waveline_899	23751.23	40.96	x	40.40	13.27	-35.56	18.12	59.08	PK*	3.00	9.54	63.52	4.44	PASS				
WLAN-CH1	V	3	Horn SN6276	1374.94	15.80	x	27.02	3.81	0.00	30.84	46.64	PK*	3.00	0.00	53.98	7.34	PASS				
WLAN-CH1	V	3	Horn SN6276	2316.75	36.50		30.11	4.99	-23.13	11.96	48.46	PK*	3.00	0.00	53.98	5.52	PASS				
WLAN-CH1	V	3	Horn SN6276	2356.00	37.30		30.17	5.06	-23.13	12.10	49.40	PK*	3.00	0.00	53.98	4.58	PASS				
WLAN-CH1	V	3	Horn SN6276	2796.00	33.70		31.35	5.53	-23.09	13.78	47.48	PK*	3.00	0.00	53.98	6.50	PASS				
WLAN-CH1	V	3	Horn SN6276	4293.95	31.50	x	34.70	6.94	-31.08	10.56	42.06	PK*	3.00	0.00	53.98	11.92	PASS				
WLAN-CH1	V	3	Horn SN6276	<b>4824.00</b>	29.10	x	35.35	7.40	-31.04	11.71	40.81	PK*	3.00	0.00	53.98	13.17	PASS				
WLAN-CH1	V	1	Horn SN6276	<b>12060.00</b>	37.59	x	40.58	8.62	-30.61	18.59	56.18	PK*	3.00	9.54	63.52	7.34	PASS				
WLAN-CH1	V	1	Horn SN6276	<b>14472.00</b>	38.22	x	42.57	9.73	-30.78	21.52	59.74	PK*	3.00	9.54	63.52	3.78	PASS				
WLAN-CH1	V	1	Horn SN6276	17955.65	38.67	x	45.77	11.15	-32.63	24.29	62.96	PK	3.00	9.54	83.52	20.56	PASS				
WLAN-CH1	V	1	Horn SN6276	17955.65	29.40	x	45.77	11.15	-32.63	24.29	53.69	AV	3.00	9.54	63.52	9.83	PASS				
WLAN-CH1	V	1	Waveline_899	<b>19296.00</b>	37.61	x	40.26	11.64	-35.23	16.67	54.28	PK*	3.00	9.54	63.52	9.24	PASS				
WLAN-CH1	V	1	Waveline_899	19915.15	39.39	x	40.30	11.87	-35.56	16.61	56.00	PK*	3.00	9.54	63.52	7.52	PASS				
WLAN-CH1	V	1	Waveline_899	23865.70	40.18	x	40.40	13.32	-35.55	18.16	58.34	PK*	3.00	9.54	63.52	5.18	PASS				

Notes:

\*PK denotes QP or Average limits applied to emissions measured with a peak detector  
**BOLD** signifies the highest signal measured near a carrier harmonic frequency  
 No EUT emissions levels were measured above those reported

Formulae:

Total CF = Antenna Factor + Cable Factor + Other Factor (Amplifier Gain, filter loss, etc)

Field Strength = SA Reading + Total CF

Limit Distance Correction = 40\*log(d1/d2) for F<30 MHz, 20\*log(d1/d2) for F > 30 MHz:

where d1 is the measurement distance, d2 is the published limit distance

**Limit = Specified Limit + Limit Distance** The frequency points reported describe the highest emission measured in each of the ranges tested and are used to describe the measured spectrum as a whole. It is shown that the highest emissions measured within the spectrum pass the appropriate restricted limits; therefore all emissions within the restricted bands would also meet the requirements. No out-of-band emissions were measured above the levels noted.

<b>Applicant:</b>	Itronix Corporation	<b>Model:</b>	IX325A775IWLBT	<b>FCC ID:</b>	KBCIX325A775IWLBT	<b>IC ID:</b>	1943A-IX325e
<b>IX325 Rugged Tablet PC with internal Intel PRO2200BG 802.11b/g WLAN &amp; Well Green Dual Internal Antenna</b>							
2005 Celltech Labs Inc.	This document is not to be reproduced in whole or in part without the prior written permission of Celltech Labs Inc.						Page 46 of 59

 Testing and Engineering Services Lab	<b>Test Report Serial No.:</b>	060605KBC-T646-E15W	<b>Report Revision No.:</b>	Rev. 0
	<b>Test Date(s):</b>	4Jul05 - 20Jul05	<b>Report Issue Date:</b>	8Dec05
	<b>Test Standard(s):</b>	FCC 47 CFR §15.247	<b>Industry Canada RSS-210 Issue 5</b>	
	<b>Lab Registration(s):</b>	FCC Lab Reg. # 714830	<b>Industry Canada Lab File #3874</b>	

E.9.9. Mode g - Channel 6 Out-of-Band Spurious Emission Field Strengths @ Specified Distance (within restricted bands)

		<b>Project Number:</b> 060605KBC-T643-E15W <b>Company:</b> Itronix <b>Product:</b> IX325 with Intel PRO 2200BG	<b>Standard:</b> FCC15.209 <b>Test Start Date:</b> 4-Jul-05 <b>Test End Date:</b> 13-Jul-05														
Channel	Polarity	Distance	Rx Antenna	Frequency	SA Level	Noise Floor	Rx AF	Rx CL	Other Rx	Total Rx CF	Field Strength	Detector	Limit Distance	Limit Distance Correction	Calculated Limit	Margin	Pass/Fail
							dB/m	dB	dB	dB/m	dBuV/m		(PK/QP/AV)	m			
WLAN-CH6	H	3	Bilog SN1607	131.55	23.70		12.23	1.15	0.00	13.38	37.08	PK*	3.00	0.00	43.52	6.44	PASS
WLAN-CH6	H	3	Horn SN6276	1058.92	15.10	x	26.58	3.35	0.00	29.94	45.04	PK*	3.00	0.00	53.98	8.94	PASS
WLAN-CH6	H	3	Horn SN6276	1584.98	15.90		27.61	4.14	0.00	31.75	47.65	PK*	3.00	0.00	53.98	6.33	PASS
WLAN-CH6	H	3	Horn SN6276	<b>4874.00</b>	29.60	x	35.45	7.60	-31.04	12.01	41.61	PK*	3.00	0.00	53.98	12.37	PASS
WLAN-CH6	H	3	Horn SN6276	<b>7311.00</b>	34.90	x	38.36	9.93	-30.84	17.46	52.36	PK	3.00	0.00	73.98	21.62	PASS
WLAN-CH6	H	3	Horn SN6276	<b>7311.00</b>	23.20	x	38.36	9.93	-30.84	17.46	40.66	AV	3.00	0.00	53.98	13.32	PASS
WLAN-CH6	H	1	Horn SN6276	17940.00	38.89	x	45.72	11.14	-32.62	24.24	63.13	PK	3.00	9.54	83.52	20.39	PASS
WLAN-CH6	H	1	Horn SN6276	17940.00	29.40	x	45.72	11.14	-32.62	24.24	53.64	AV	3.00	9.54	63.52	9.88	PASS
WLAN-CH6	H	1	Waveline_899	<b>19496.00</b>	37.51		40.30	11.71	-35.33	16.68	54.19	PK*	3.00	9.54	63.52	9.33	PASS
WLAN-CH6	H	1	Waveline_899	23800.23	40.59		40.40	13.29	-35.56	18.14	58.73	PK*	3.00	9.54	63.52	4.79	PASS
WLAN-CH6	V	3	Horn SN6276	1081.94	20.10		26.61	3.37	0.00	29.98	50.08	PK*	3.00	0.00	53.98	3.90	PASS
WLAN-CH6	V	3	Horn SN6276	1089.96	22.30		26.63	3.39	0.00	30.01	52.31	PK	3.00	0.00	73.98	21.66	PASS
WLAN-CH6	V	3	Horn SN6276	1089.96	22.50		26.63	3.39	0.00	30.01	52.51	AV	3.00	0.00	53.98	1.46	PASS
WLAN-CH6	V	3	Horn SN6276	1586.99	15.90		27.62	4.14	0.00	31.76	47.66	PK*	3.00	0.00	53.98	6.32	PASS
WLAN-CH6	V	3	Horn SN6276	2317.57	37.30		30.11	4.99	-23.13	11.96	49.26	PK*	3.00	0.00	53.98	4.72	PASS
WLAN-CH6	V	3	Horn SN6276	2754.04	34.40		31.21	5.50	-23.10	13.61	48.01	PK*	3.00	0.00	53.98	5.97	PASS
WLAN-CH6	V	3	Horn SN6276	2751.48	33.60		31.20	5.49	-23.10	13.59	47.19	PK*	3.00	0.00	53.98	6.79	PASS
WLAN-CH6	V	3	Horn SN6276	3758.09	30.90	x	34.02	6.46	-31.13	9.36	40.26	PK*	3.00	0.00	53.98	13.72	PASS
WLAN-CH6	V	3	Horn SN6276	<b>4874.00</b>	29.40	x	35.45	7.60	-31.04	12.01	41.41	PK*	3.00	0.00	53.98	12.57	PASS
WLAN-CH6	V	3	Horn SN6276	<b>7311.00</b>	34.00	x	38.36	9.93	-30.84	17.46	51.46	PK	3.00	0.00	73.98	22.52	PASS
WLAN-CH6	V	3	Horn SN6276	<b>7311.00</b>	23.30	x	38.36	9.93	-30.84	17.46	40.76	AV	3.00	0.00	53.98	13.22	PASS
WLAN-CH6	V	1	Horn SN6276	<b>12185.00</b>	36.17	x	40.76	8.68	-30.61	18.83	55.00	PK*	3.00	9.54	63.52	8.52	PASS
WLAN-CH6	V	1	Horn SN6276	14489.10	39.04	x	42.59	9.74	-30.79	21.54	60.58	PK*	3.00	9.54	63.52	2.94	PASS
WLAN-CH6	V	1	Horn SN6276	17824.13	39.12	x	45.37	11.10	-32.56	23.92	63.04	PK	3.00	9.54	83.52	20.49	PASS
WLAN-CH6	V	1	Horn SN6276	17824.13	29.70	x	45.37	11.10	-32.56	23.92	53.62	AV	3.00	9.54	63.52	9.91	PASS
WLAN-CH6	V	1	Waveline_899	<b>19496.00</b>	37.10		40.30	11.71	-35.33	16.68	53.78	PK*	3.00	9.54	63.52	9.74	PASS
WLAN-CH6	V	1	Waveline_899	19952.95	39.47		40.30	11.88	-35.58	16.61	56.08	PK*	3.00	9.54	63.52	7.45	PASS
WLAN-CH6	V	1	Waveline_899	23969.63	40.56		40.40	13.36	-35.55	18.20	58.76	PK*	3.00	9.54	63.52	4.76	PASS

Notes:

\*PK denotes QP or Average limits applied to emissions measured with a peak detector

**BOLD** signifies the highest signal measured near a carrier harmonic frequency

No EUT emissions levels were measured above those reported

Formulae:

Total CF = Antenna Factor + Cable Factor + Other Factor (Amplifier Gain, filter loss, etc)

Field Strength = SA Reading + Total CF

Limit Distance Correction = 40\*log(d1/d2) for F<30 MHz, 20\*log(d1/d2) for F > 30 MHz:

where d1 is the measurement distance, d2 is the published limit distance

**Limit = Specified Limit + Limit Distance** The frequency points reported describe the highest emission measured in each of the ranges tested and are used to describe the measured spectrum as a whole. It is shown that the highest emissions measured within the spectrum pass the appropriate restricted limits; therefore all emissions within the restricted bands would also meet the requirements. No out-of-band emissions were measured above the levels noted.

<b>Applicant:</b>	Itronix Corporation	<b>Model:</b>	IX325A775IWLBT	<b>FCC ID:</b>	KBCIX325A775IWLBT	<b>IC ID:</b>	1943A-IX325e
IX325 Rugged Tablet PC with internal Intel PRO2200BG 802.11b/g WLAN & Well Green Dual Internal Antenna							
2005 Celltech Labs Inc.	This document is not to be reproduced in whole or in part without the prior written permission of Celltech Labs Inc.						Page 47 of 59

	<b>Test Report Serial No.:</b>	060605KBC-T646-E15W	<b>Report Revision No.:</b>	Rev. 0
	<b>Test Date(s):</b>	4Jul05 - 20Jul05	<b>Report Issue Date:</b>	8Dec05
	<b>Test Standard(s):</b>	FCC 47 CFR §15.247	Industry Canada RSS-210 Issue 5	
	<b>Lab Registration(s):</b>	FCC Lab Reg. # 714830	Industry Canada Lab File #3874	

E.9.10. Mode g - Channel 11 Out-of-Band Spurious Emission Field Strengths @ Specified Distance (within restricted bands)

		Project Number:	060605KBC-T643-E15W		Standard:	FCC15.209											
		Company:	Itronix		Test Start Date:	4-Jul-05											
		Product:	IX325 with Intel PRO 2200BG		Test End Date:	13-Jul-05											
Channel	Polarity	Distance	Rx Antenna	Frequency	SA Level	Noise Floor	Rx AF	Rx CL	Other Rx	Total Rx CF	Field Strength	Detector	Limit Distance	Limit Distance Correction	Calculated Limit	Margin	Pass/Fail
WLAN-CH11	H	3	Horn SN6276	1126.08	17.60		26.68	3.46	0.00	30.13	47.73	PK*	3.00	0.00	53.98	6.25	PASS
WLAN-CH11	H	3	Horn SN6276	1181.11	15.50		26.75	3.53	0.00	30.29	45.79	PK*	3.00	0.00	53.98	8.19	PASS
WLAN-CH11	H	3	Horn SN6276	1589.26	17.10		27.63	4.14	0.00	31.77	48.87	PK*	3.00	0.00	53.98	5.11	PASS
WLAN-CH11	H	3	Horn SN6276	2321.74	34.00		30.11	5.00	-23.13	11.98	45.98	PK*	3.00	0.00	53.98	8.00	PASS
WLAN-CH11	H	3	Horn SN6276	<b>4924.00</b>	29.50		35.55	7.53	-31.03	12.05	41.55	PK*	3.00	0.00	53.98	12.43	PASS
WLAN-CH11	H	3	Horn SN6276	<b>7386.00</b>	33.80		38.49	9.94	-30.83	17.61	51.41	PK*	3.00	0.00	53.98	2.57	PASS
WLAN-CH11	H	3	Horn SN6276	9317.12	35.60		40.26	11.62	-30.73	21.16	56.76	PK	3.00	0.00	73.98	17.22	PASS
WLAN-CH11	H	3	Horn SN6276	9317.12	22.40		40.26	11.62	-30.73	21.16	43.56	AV	3.00	0.00	53.98	10.42	PASS
WLAN-CH11	H	1	Horn SN6276	<b>12310.00</b>	37.65		40.93	8.74	-30.60	19.07	56.72	PK*	3.00	9.54	63.52	6.80	PASS
WLAN-CH11	H	1	Horn SN6276	17920.10	39.03		45.66	11.14	-32.61	24.19	63.22	PK	3.00	9.54	83.52	20.30	PASS
WLAN-CH11	H	1	Horn SN6276	17920.10	29.50		45.66	11.14	-32.61	24.19	53.69	AV	3.00	9.54	63.52	9.83	PASS
WLAN-CH11	H	1	Waveline_899	<b>19696.00</b>	37.48		40.30	11.79	-35.44	16.65	54.13	PK*	3.00	9.54	63.52	9.39	PASS
WLAN-CH11	H	1	Waveline_899	19933.15	38.15		40.30	11.87	-35.56	16.61	54.76	PK*	3.00	9.54	63.52	8.76	PASS
WLAN-CH11	H	1	Waveline_899	<b>22158.00</b>	37.73		40.33	12.69	-35.57	17.45	55.18	PK*	3.00	9.54	63.52	8.34	PASS
WLAN-CH11	H	1	Waveline_899	23754.20	39.67		40.40	13.28	-35.56	18.12	57.79	PK	3.00	9.54	83.52	25.73	PASS
WLAN-CH11	V	3	Horn SN6276	1030.17	15.60		28.54	3.39	0.00	29.94	45.54	PK*	3.00	0.00	53.98	8.44	PASS
WLAN-CH11	V	3	Horn SN6276	1061.03	15.80		26.59	3.36	0.00	29.94	45.74	PK*	3.00	0.00	53.98	8.24	PASS
WLAN-CH11	V	3	Horn SN6276	1590.66	15.60		27.64	4.14	0.00	31.78	47.38	PK*	3.00	0.00	53.98	6.60	PASS
WLAN-CH11	V	3	Horn SN6276	2713.72	35.20		31.08	5.43	-23.10	13.41	48.61	PK*	3.00	0.00	53.98	5.37	PASS
WLAN-CH11	V	3	Horn SN6276	2754.68	35.80		31.21	5.50	-23.10	13.61	49.41	PK*	3.00	0.00	53.98	4.56	PASS
WLAN-CH11	V	3	Horn SN6276	2795.16	37.60		31.34	5.53	-23.10	13.78	51.38	PK	3.00	0.00	73.98	22.60	PASS
WLAN-CH11	V	3	Horn SN6276	2795.16	23.80		31.34	5.53	-23.10	13.78	37.58	AV	3.00	0.00	53.98	16.40	PASS
WLAN-CH11	V	3	Horn SN6276	4296.53	37.90		34.70	6.95	-31.08	10.56	48.46	PK*	3.00	0.00	53.98	5.52	PASS
WLAN-CH11	V	3	Horn SN6276	<b>4924.00</b>	29.60		35.55	7.53	-31.03	12.05	41.65	PK*	3.00	0.00	53.98	12.33	PASS
WLAN-CH11	V	3	Horn SN6276	<b>7386.00</b>	33.60		38.49	9.94	-30.83	17.61	51.21	PK	3.00	0.00	73.98	22.77	PASS
WLAN-CH11	V	3	Horn SN6276	<b>7386.00</b>	23.00		38.49	9.94	-30.83	17.61	40.61	AV	3.00	0.00	53.98	13.37	PASS
WLAN-CH11	V	3	Horn SN6276	8321.27	35.10		39.29	10.43	-30.77	18.96	54.06	PK	3.00	0.00	73.98	19.92	PASS
WLAN-CH11	V	3	Horn SN6276	8321.27	21.90		39.29	10.43	-30.77	18.96	40.86	AV	3.00	0.00	53.98	13.12	PASS
WLAN-CH11	V	1	Horn SN6276	<b>12310.00</b>	37.37		40.93	8.74	-30.60	19.07	56.44	PK*	3.00	9.54	63.52	7.08	PASS
WLAN-CH11	V	1	Horn SN6276	13286.80	40.26		41.83	9.19	-30.56	20.45	60.71	PK	3.00	9.54	83.52	22.81	PASS
WLAN-CH11	V	1	Horn SN6276	13286.80	27.20		41.83	9.19	-30.56	20.45	47.65	AV	3.00	9.54	63.52	15.87	PASS
WLAN-CH11	V	1	Horn SN6276	17987.78	39.04		45.86	11.16	-32.64	24.38	63.42	PK	3.00	9.54	83.52	20.10	PASS
WLAN-CH11	V	1	Horn SN6276	17987.78	29.30		45.86	11.16	-32.64	24.38	53.68	AV	3.00	9.54	63.52	9.84	PASS
WLAN-CH11	V	1	Waveline_899	19342.25	38.74		40.27	11.66	-35.25	16.67	55.41	PK*	3.00	9.54	63.52	8.11	PASS
WLAN-CH11	V	1	Waveline_899	<b>19696.00</b>	37.00		40.30	11.79	-35.44	16.65	53.65	PK*	3.00	9.54	63.52	9.87	PASS
WLAN-CH11	V	1	Waveline_899	<b>22158.00</b>	36.82		40.33	12.69	-35.57	17.45	54.27	PK*	3.00	9.54	63.52	9.25	PASS
WLAN-CH11	V	1	Waveline_899	23952.15	40.54		40.40	13.35	-35.55	18.19	58.73	PK*	3.00	9.54	63.52	4.79	PASS

**Notes:**  
\*PK denotes QP or Average limits applied to emissions measured with a peak detector  
**BOLD** signifies the highest signal measured near a carrier harmonic frequency  
No EUT emissions levels were measured above those reported  
**Formulae:**  
Total CF = Antenna Factor + Cable Factor + Other Factor (Amplifier Gain, filter loss, etc)  
Field Strength = SA Reading + Total CF  
Limit Distance Correction = 40\*log(d1/d2) for F<30 MHz, 20\*log(d1/d2) for F> 30 MHz:  
where d1 is the measurement distance, d2 is the published limit distance

**Limit = Specified Limit + Limit Distance** The frequency points reported describe the highest emission measured in each of the ranges tested and are used to describe the measured spectrum as a whole. It is shown that the highest emissions measured within the spectrum pass the appropriate restricted limits; therefore all emissions within the restricted bands would also meet the requirements. No out-of-band emissions were measured above the levels noted.

<b>Applicant:</b>	Itronix Corporation	<b>Model:</b>	IX325A775IWLBT	<b>FCC ID:</b>	KBCIX325A775IWLBT	<b>IC ID:</b>	1943A-IX325e
<b>IX325 Rugged Tablet PC with internal Intel PRO2200BG 802.11b/g WLAN &amp; Well Green Dual Internal Antenna</b>							
2005 Celltech Labs Inc.	This document is not to be reproduced in whole or in part without the prior written permission of Celltech Labs Inc.						Page 48 of 59

	<b>Test Report Serial No.:</b>	060605KBC-T646-E15W	<b>Report Revision No.:</b>	Rev. 0
	<b>Test Date(s):</b>	4Jul05 - 20Jul05	<b>Report Issue Date:</b>	8Dec05
	<b>Test Standard(s):</b>	FCC 47 CFR §15.247	Industry Canada RSS-210 Issue 5	
	<b>Lab Registration(s):</b>	FCC Lab Reg. # 714830	Industry Canada Lab File #3874	

### E.10. PASS/FAIL

In reference to the results outlined in F.9, the DUT passes the requirements as stated in the reference standards as follows:

FCC 15.205 (a) (b) and 15.209 (a): No emissions were measured within the restricted bands as outlined in 15.205 that exceeded the limits stated in 15.209.

### E.11. SIGN-OFF

I attest to the accuracy of the data. All measurements reported herein were performed by me and are correct to the best of my knowledge and belief. I assume full responsibility for the completeness of these measurements.



\_\_\_\_\_  
 Russell Pipe  
 Senior Compliance Technologist  
 Celltech Labs Inc.

\_\_\_\_\_  
 13Jul05

Date

<b>Applicant:</b>	Itronix Corporation	<b>Model:</b>	IX325A775IWLBT	<b>FCC ID:</b>	KBCIX325A775IWLBT	<b>IC ID:</b>	1943A-IX325e
<b>IX325 Rugged Tablet PC with internal Intel PRO2200BG 802.11b/g WLAN &amp; Well Green Dual Internal Antenna</b>							
2005 Celltech Labs Inc.	This document is not to be reproduced in whole or in part without the prior written permission of Celltech Labs Inc.						Page 49 of 59

	<b>Test Report Serial No.:</b>	060605KBC-T646-E15W	<b>Report Revision No.:</b>	Rev. 0
	<b>Test Date(s):</b>	4Jul05 - 20Jul05	<b>Report Issue Date:</b>	8Dec05
	<b>Test Standard(s):</b>	FCC 47 CFR §15.247	Industry Canada RSS-210 Issue 5	
	<b>Lab Registration(s):</b>	FCC Lab Reg. # 714830	Industry Canada Lab File #3874	

## Appendix F - Peak Power Spectral Density Measurement

F.1. REFERENCES	
<b>Normative Reference Standard</b>	FCC CFR 47 §15.247(d)
<b>Procedure Reference</b>	FCC Bulletin KDB Publication No 558074

F.2. LIMITS	
F.2.1. FCC CFR	
<p>§15.247(d): For digitally modulated systems, the peak power spectral density conducted from the intentional radiator to the antenna shall not be greater than +8 dBm in any 3 kHz band during any time interval of continuous transmission.</p>	

F.3. ENVIRONMENTAL CONDITIONS	
<b>Temperature</b>	25 +/- 2 °C
<b>Humidity</b>	35 +/- 2 %
<b>Barometric Pressure</b>	96 kPa

F.4. EQUIPMENT LIST					
ASSET NUMBER	MANUFACTURER	MODEL	DESCRIPTION	LAST CAL	CAL DUE
00015	Agilent	E4408B	Spectrum Analyzer	24Jan05	24Jan06
00075	Alpha Wire-J	9223	1ft. RG223/U RF Cable	na*	na
00076	Pasternack	PE7014-30	30dB 2 Watt Attenuator	na*	na

\*Cable and attenuator verified with power meter prior to use

<b>Applicant:</b>	Itronix Corporation	<b>Model:</b>	IX325A775IWLBT	<b>FCC ID:</b>	KBCIX325A775IWLBT	<b>IC ID:</b>	1943A-IX325e
IX325 Rugged Tablet PC with internal Intel PRO2200BG 802.11b/g WLAN & Well Green Dual Internal Antenna							
2005 Celltech Labs Inc.	This document is not to be reproduced in whole or in part without the prior written permission of Celltech Labs Inc.						Page 50 of 59

	<b>Test Report Serial No.:</b>	060605KBC-T646-E15W	<b>Report Revision No.:</b>	Rev. 0
	<b>Test Date(s):</b>	4Jul05 - 20Jul05	<b>Report Issue Date:</b>	8Dec05
	<b>Test Standard(s):</b>	FCC 47 CFR §15.247	Industry Canada RSS-210 Issue 5	
	<b>Lab Registration(s):</b>	FCC Lab Reg. # 714830	Industry Canada Lab File #3874	

### F.5. MEASUREMENT EQUIPMENT SETUP

<b>Measurement Equipment Connections</b>	The equipment was connected as shown in the setup drawing in G.6.
<b>Measurement Equipment Settings</b>	To evaluate the occupied bandwidth, software and a PC controller were used to set the spectrum analyzer using the following setting: RBW – 3 kHz VBW – 30 kHz Detector – Sample Average – Power Trace Average – 100 Offset – appropriate for external attenuation (-31.4 dB)
<b>Measurement Procedure</b>	The power spectral density measurement was performed using the PSD Option 2 method described in the FCC document KDB Publication No. 558074.

### F.6. SETUP DRAWING

Figure F.6-1 - Setup Drawing

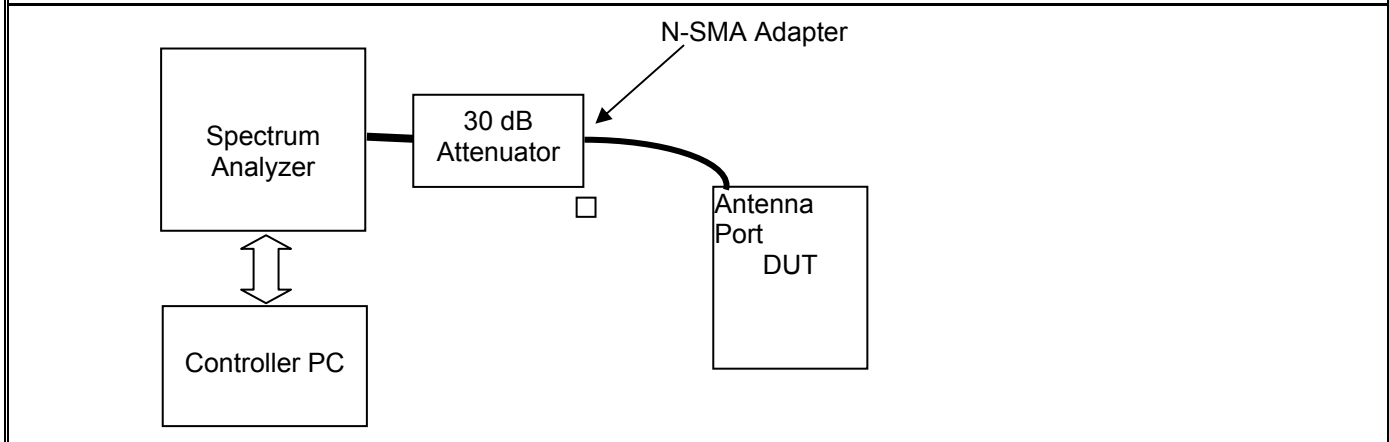

<b>Applicant:</b>	Itronix Corporation	<b>Model:</b>	IX325A775IWLBT	<b>FCC ID:</b>	KBCIX325A775IWLBT	<b>IC ID:</b>	1943A-IX325e
<b>IX325 Rugged Tablet PC with internal Intel PRO2200BG 802.11b/g WLAN &amp; Well Green Dual Internal Antenna</b>							
2005 Celltech Labs Inc.	This document is not to be reproduced in whole or in part without the prior written permission of Celltech Labs Inc.						Page 51 of 59





	<b>Test Report Serial No.:</b>	060605KBC-T646-E15W	<b>Report Revision No.:</b>	Rev. 0
	<b>Test Date(s):</b>	4Jul05 - 20Jul05	<b>Report Issue Date:</b>	8Dec05
	<b>Test Standard(s):</b>	FCC 47 CFR §15.247	Industry Canada RSS-210 Issue 5	
	<b>Lab Registration(s):</b>	FCC Lab Reg. # 714830	Industry Canada Lab File #3874	

F.7. TEST RESULTS						
Channel	802.11b			802.11g		
	Frequency (GHz)	PPSD (dBm)	Data Rate Mb/s	Frequency (GHz)	PPSD (dBm)	Data Rate Mb/s
Low	2.412	-11.97	1	2.412	-18.35	6
Mid	2.437	-10.54	1	2.437	-18.02	6
High	2.462	-11.37	1	2.462	-17.06	6

F.8. PASS/FAIL
In reference to the results outlined in G.5, the DUT passes the requirements as stated in the reference standards as follows:  FCC 15.247 (d): <u>The peak power spectral density did not exceed +8 dBm in any 3 kHz band.</u>

F.9. SIGN-OFF
I attest to the accuracy of the data. All measurements reported herein were performed by me and are correct to the best of my knowledge and belief. I assume full responsibility for the completeness of these measurements.
 <hr/> Alex Yuan EMC Technologist Celltech Labs Inc.  17Jul05 <hr/> Date

<b>Applicant:</b>	Itronix Corporation	<b>Model:</b>	IX325A775IWLBT	<b>FCC ID:</b>	KBCIX325A775IWLBT	<b>IC ID:</b>	1943A-IX325e
IX325 Rugged Tablet PC with internal Intel PRO2200BG 802.11b/g WLAN & Well Green Dual Internal Antenna							
2005 Celltech Labs Inc.	This document is not to be reproduced in whole or in part without the prior written permission of Celltech Labs Inc.						Page 52 of 59

	<b>Test Report Serial No.:</b>	060605KBC-T646-E15W	<b>Report Revision No.:</b>	Rev. 0
	<b>Test Date(s):</b>	4Jul05 - 20Jul05	<b>Report Issue Date:</b>	8Dec05
	<b>Test Standard(s):</b>	FCC 47 CFR §15.247	Industry Canada RSS-210 Issue 5	
	<b>Lab Registration(s):</b>	FCC Lab Reg. # 714830	Industry Canada Lab File #3874	

## Appendix G - Conducted Powerline Emissions Measurement

### G.1. REFERENCES

<b>Normative Reference Standard</b>	CFR 47 FCC Part 15 §15.207
<b>Procedure Reference</b>	ANSI C63.4

### G.2. LIMITS

§15.207: Compliance with the provisions of this paragraph shall be based on the measurement of the radio frequency voltage between each powerline and ground at the power terminal.

Frequency of Emission (MHz)	Conducted Limit (dBuV)	
	Quasi-Peak	Average
0.15 – 0.5	66 to 56*	56 to 46*
0.50 – 5.0	56	46
5.0 – 30.0	60	50

\*Decreases logarithmically with frequency.

### G.3. ENVIRONMENTAL CONDITIONS

<b>Temperature</b>	+26 ± 5 °C
<b>Humidity</b>	31 % ± 10% RH
<b>Barometric Pressure</b>	101.4 kpa

### G.4. EQUIPMENT LIST

ASSET NUMBER	MANUFACTURER	MODEL	DESCRIPTION	LAST CAL	CAL DUE
00049	HP	85650A	Quasi-Peak Adapter	13Apr05	13Apr06
00047	HP	85685A	RF Preselector	13Apr05	13Apr06
00051	HP	8566B	Spectrum Analyzer RF Section	12Apr05	12Apr06
00083	EMCO	3825/2	Line Impedance Stabilization Network	26Apr05	26Apr06
00084	EMCO	3825/2	Line Impedance Stabilization Network	26Apr05	26Apr06

### G.5. MEASUREMENT EQUIPMENT SETUP

<b>MEASUREMENT EQUIPMENT CONNECTIONS</b>	The conducted emissions were measured on each of the two AC powerline leads connected to the DUT's power supply brick. A two line LISN was used to make this measurement. A drawing of the equipment setup is shown in H.7
<b>MEASUREMENT EQUIPMENT SETTINGS</b>	<p>Each of the monitor ports from the 2-line LISN was connected in turn to the spectrum analyzer. The port not connected to the analyzer was terminated in a 50-ohm load. A prescan of the peak emission levels was made of the 150 kHz – 30 MHz range split into 4 equal frequency bands. The following were the spectrum analyzer settings:</p> <p>Start Frequency and Stop Frequency set by software for each of the four bands  RBW: 100 kHz  VBW: 300 kHz  Sweep: 500 mS</p> <p>The resulting data from each band was corrected and collected by software and presented in the graphical representations shown in H.9 for the two leads. The frequency points with the highest 10 levels on each lead were used by software to optimize a set of 20 readings for each type of detector (peak, quasi-peak and average). This data was corrected by the software is presented in the tables shown in section H.9.</p>

<b>Applicant:</b>	Itronix Corporation	<b>Model:</b>	IX325A775IWLBT	<b>FCC ID:</b>	KBCIX325A775IWLBT	<b>IC ID:</b>	1943A-IX325e
<b>IX325 Rugged Tablet PC with internal Intel PRO2200BG 802.11b/g WLAN &amp; Well Green Dual Internal Antenna</b>							
2005 Celltech Labs Inc.	This document is not to be reproduced in whole or in part without the prior written permission of Celltech Labs Inc.						Page 53 of 59

### G.6. SETUP DRAWING

Figure G.6-1 - Setup Drawing

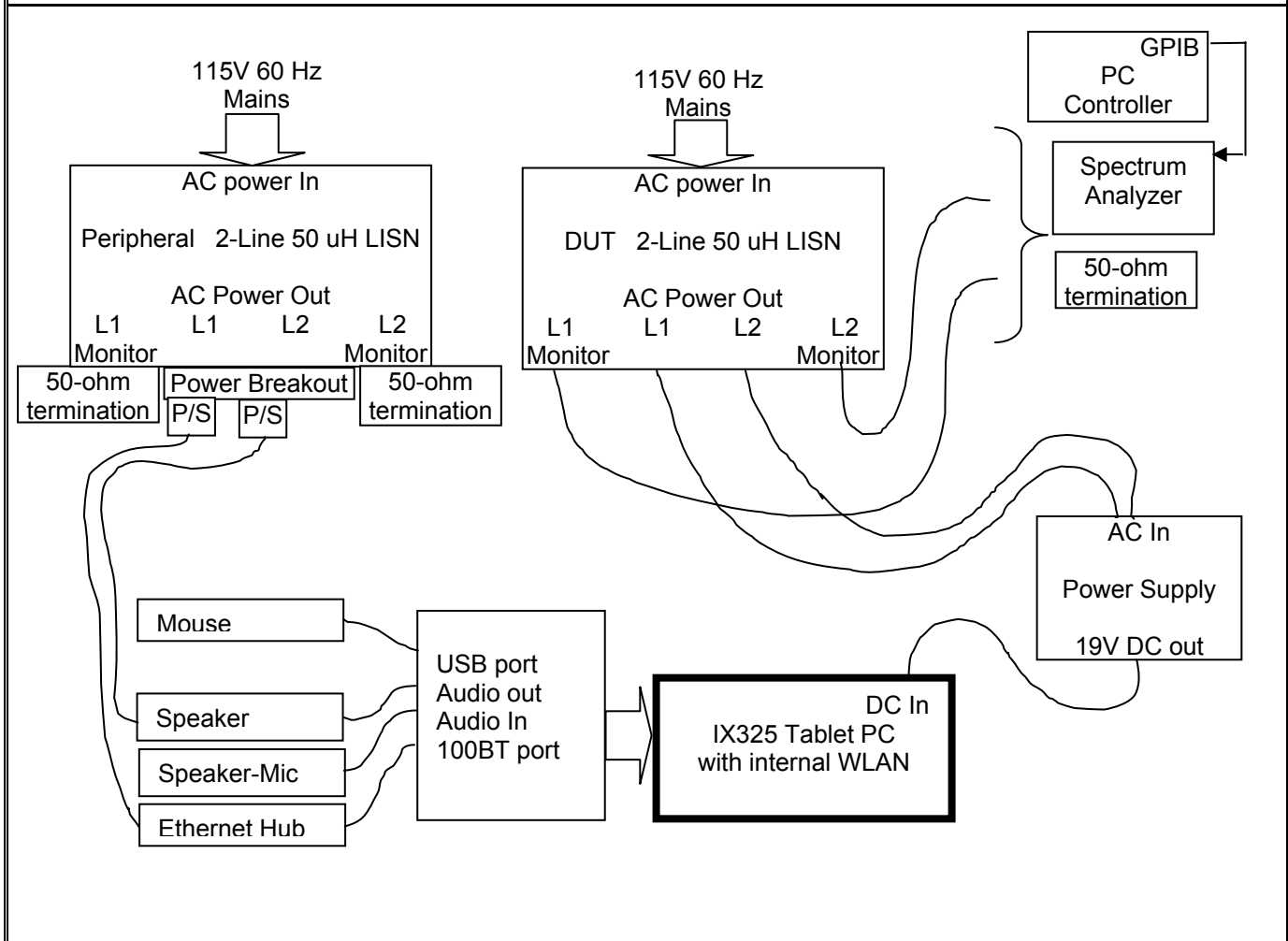

	<b>Test Report Serial No.:</b>	060605KBC-T646-E15W	<b>Report Revision No.:</b>	Rev. 0
	<b>Test Date(s):</b>	4Jul05 - 20Jul05	<b>Report Issue Date:</b>	8Dec05
	<b>Test Standard(s):</b>	FCC 47 CFR §15.247	Industry Canada RSS-210 Issue 5	
	<b>Lab Registration(s):</b>	FCC Lab Reg. # 714830	Industry Canada Lab File #3874	

**G.7. SETUP PHOTOS**

Photograph G-1 - AC Powerline Conducted Emission Cable Placement

Photograph G-2 - AC Powerline Conducted Emission Configuration



<b>G.8. DUT OPERATING DESCRIPTION</b>	
<b>WLAN:</b>	The WLAN was set to transmit at full power on Channel 1, Mode b 1 Mb/s
<b>PC:</b>	Other than operating the WLAN software and running MS windows, no PC exercising was performed.
<b>Peripherals:</b>	All peripherals were active, but no specific traffic was initiated.

<b>Applicant:</b>	Itronix Corporation	<b>Model:</b>	IX325A775IWLBT	<b>FCC ID:</b>	KBCIX325A775IWLBT	<b>IC ID:</b>	1943A-IX325e
<b>IX325 Rugged Tablet PC with internal Intel PRO2200BG 802.11b/g WLAN &amp; Well Green Dual Internal Antenna</b>							
2005 Celltech Labs Inc.	This document is not to be reproduced in whole or in part without the prior written permission of Celltech Labs Inc.						Page 55 of 59



<b>Test Report Serial No.:</b>	060605KBC-T646-E15W	<b>Report Revision No.:</b>	Rev. 0
<b>Test Date(s):</b>	4Jul05 - 20Jul05	<b>Report Issue Date:</b>	8Dec05
<b>Test Standard(s):</b>	FCC 47 CFR §15.247	Industry Canada RSS-210 Issue 5	
<b>Lab Registration(s):</b>	FCC Lab Reg. # 714830	Industry Canada Lab File #3874	

## G.9. TEST RESULTS

### G.9.1. Line 1 Conducted Emissions

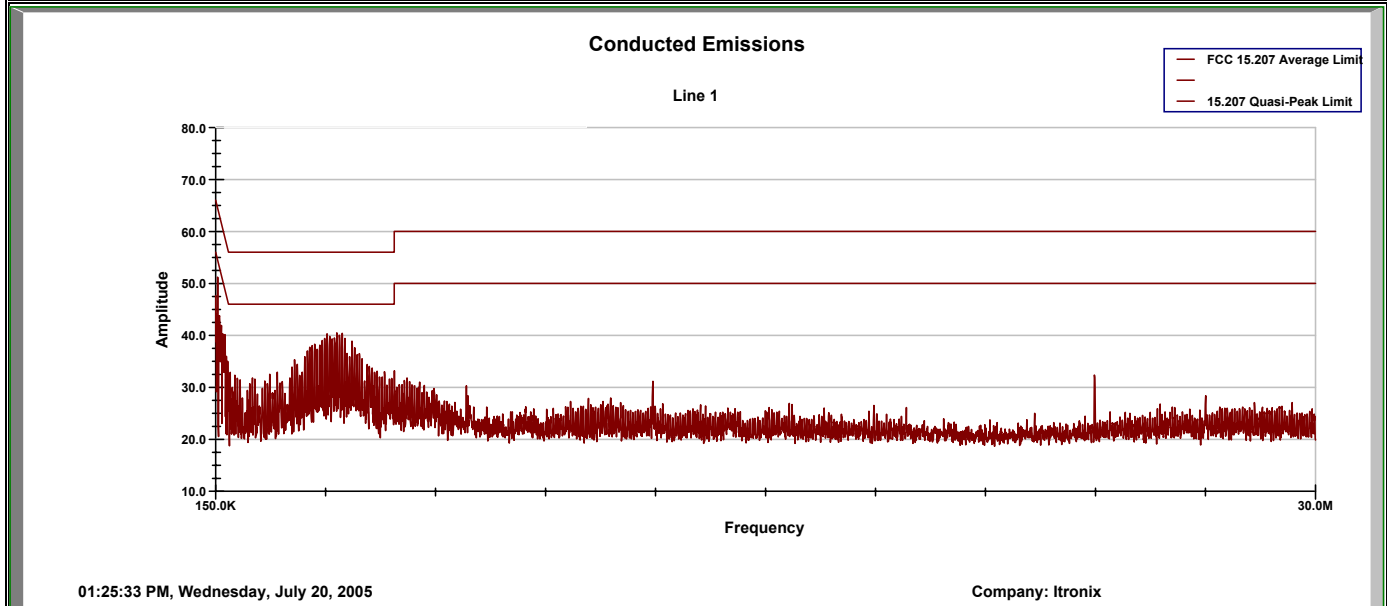

**Project Number:** 060605KBC-T643-E15W  
**Company:** Itronix  
**Product:** IX325 with INTEL PRO2200BG WLAN

**Standard:** FCC 15.207  
**Test Start Date:** 20-Jul-05  
**Test End Date:** 20-Jul-05

Line 1 Conducted Emissions												
Frequency MHz	Uncorrected Reading			Correction Factor dB	Corrected Emission Level			Quasi-Peak Limit dBuV	Quasi-Peak Margin dB	Average Limit dBuV	Average Margin dB	Pass/Fail
	Peak dBuV	Quasi-Peak dBuV	Average dBuV		Peak dBuV	Quasi-Peak dBuV	Average dBuV					
0.151	64.20	55.89	32.34	-2.13	62.07	53.76	30.21	65.96	12.20	55.96	25.75	Pass
0.165	63.20	52.62	27.98	-1.88	61.32	50.74	26.10	65.19	14.45	55.19	29.09	Pass
0.201	58.50	48.70	28.60	-1.43	57.07	47.27	27.17	63.59	16.31	53.59	26.41	Pass
0.210	58.10	47.70	21.27	-1.34	56.76	46.36	19.93	63.22	16.86	53.22	33.29	Pass
0.239	55.10	44.81	19.03	-1.12	53.98	43.69	17.91	62.15	18.46	52.15	34.24	Pass
0.247	54.00	42.69	19.23	-1.07	52.93	41.62	18.16	61.85	20.23	51.85	33.69	Pass
0.255	52.30	42.32	16.90	-1.02	51.28	41.30	15.88	61.58	20.28	51.58	35.70	Pass
0.261	52.80	41.93	17.17	-0.98	51.82	40.95	16.19	61.39	20.44	51.39	35.20	Pass
0.274	51.20	41.79	18.52	-0.93	50.27	40.86	17.59	60.99	20.12	50.99	33.40	Pass
0.406	45.80	40.18	38.22	-0.58	45.22	39.60	37.64	57.72	18.12	47.72	10.08	Pass
3.443	41.70	39.99	38.40	-0.30	41.40	39.69	38.10	56.00	16.31	46.00	7.90	Pass
3.579	42.40	39.93	38.72	-0.31	42.10	39.63	38.41	56.00	16.38	46.00	7.59	Pass
4.992	34.60	30.32	27.34	-0.31	34.29	30.01	27.03	56.00	25.99	46.00	18.97	Pass
24.000	35.00	33.39	31.98	-0.45	34.55	32.94	31.53	60.00	27.06	50.00	18.47	Pass

Corrected Emission Level (dBuV) = Uncorrected Reading (dBuV) + Correction Factor (dB)  
 Margin (dB) = Limit (dBuV) - Corrected Emission Level (dBuV)

### Calculations

CF = Correction Factor  
 Emission Level = Measured Level + correction factor  
 Margin = Limit - Emission Level

<b>Applicant:</b> Itronix Corporation	<b>Model:</b> IX325A775IWLBT	<b>FCC ID:</b> KBCIX325A775IWLBT	<b>IC ID:</b> 1943A-IX325e
<b>IX325 Rugged Tablet PC with internal Intel PRO2200BG 802.11b/g WLAN &amp; Well Green Dual Internal Antenna</b>			
2005 Celltech Labs Inc.	This document is not to be reproduced in whole or in part without the prior written permission of Celltech Labs Inc.		Page 56 of 59



<b>Test Report Serial No.:</b>	060605KBC-T646-E15W	<b>Report Revision No.:</b>	Rev. 0
<b>Test Date(s):</b>	4Jul05 - 20Jul05	<b>Report Issue Date:</b>	8Dec05
<b>Test Standard(s):</b>	FCC 47 CFR §15.247	Industry Canada RSS-210 Issue 5	
<b>Lab Registration(s):</b>	FCC Lab Reg. # 714830	Industry Canada Lab File #3874	

### G.9.2. Line 2 Conducted Emissions

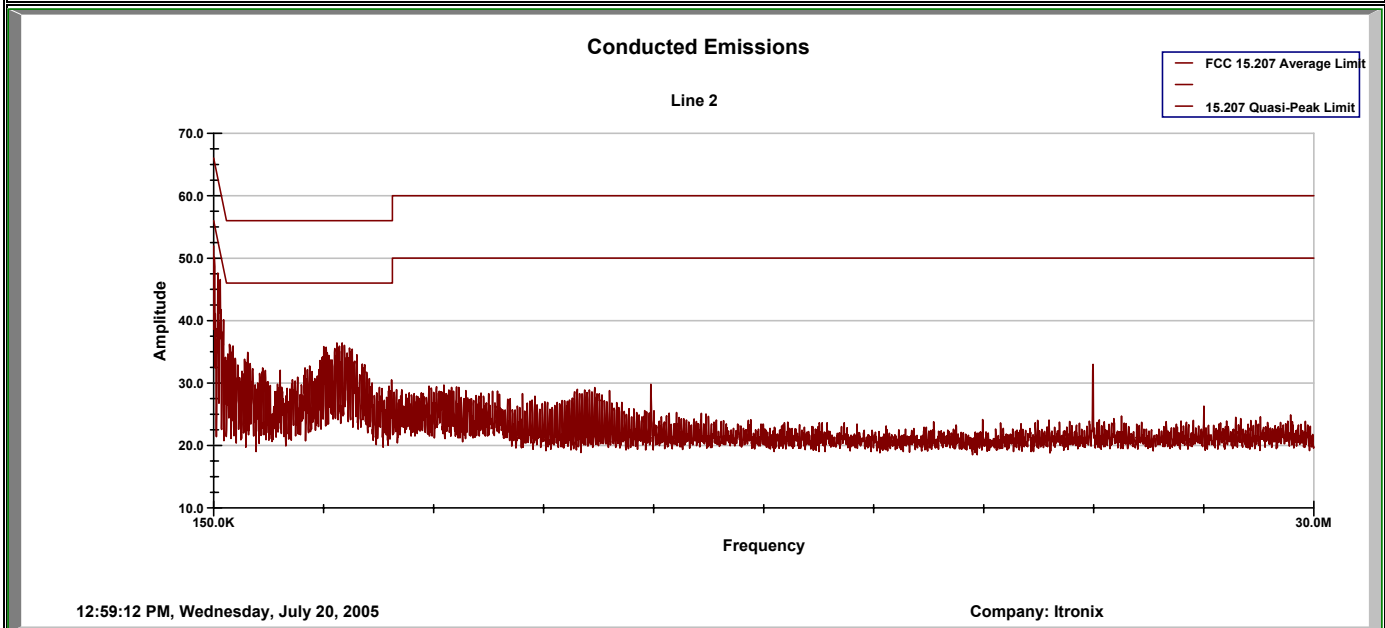

**Project Number:** 060605KBC-T643-E15W  
**Company:** Itronix  
**Product:** IX325 with INTEL PRO2200BG WLAN

**Standard:** FCC 15.207  
**Test Start Date:** 20-Jul-05  
**Test End Date:** 20-Jul-05

#### Line 2 Conducted Emissions

Frequency MHz	Uncorrected Reading			Correction Factor dB	Corrected Emission Level			Quasi-Peak Limit dBuV	Quasi-Peak Margin dB	Average Limit dBuV	Average Margin dB	Pass/Fail
	Peak dBuV	Quasi-Peak dBuV	Average dBuV		Peak dBuV	Quasi-Peak dBuV	Average dBuV					
0.150	64.80	55.57	33.03	-2.14	62.66	53.43	30.88	65.98	12.55	55.98	25.10	Pass
0.165	63.20	54.10	29.12	-1.88	61.32	52.22	27.23	65.18	12.97	55.18	27.95	Pass
0.172	61.70	53.85	27.48	-1.79	59.91	52.06	25.69	64.88	12.81	54.88	29.18	Pass
0.181	61.60	51.27	24.59	-1.67	59.93	49.60	22.92	64.46	14.86	54.46	31.54	Pass
0.194	58.80	49.58	22.96	-1.50	57.30	48.08	21.45	63.86	15.78	53.86	32.40	Pass
0.263	54.60	42.73	20.67	-0.99	53.61	41.74	19.68	61.34	19.60	51.34	31.67	Pass
0.331	48.50	38.38	28.81	-0.73	47.78	37.66	28.08	59.41	21.76	49.41	21.33	Pass
0.335	50.50	40.79	37.43	-0.72	49.78	40.07	36.71	59.32	19.25	49.32	12.61	Pass
3.501	38.80	35.67	34.20	-0.30	38.50	35.37	33.91	56.00	20.63	46.00	12.09	Pass
23.998	34.40	32.50	30.83	-0.43	33.97	32.07	30.40	60.00	27.93	50.00	19.60	Pass

Corrected Emission Level (dBuV) = Uncorrected Reading (dBuV) + Correction Factor (dB)  
 Margin (dB) = Limit (dBuV) - Corrected Emission Level (dBuV)

#### Calculations

CF = Correction Factor  
 Emission Level = Measured Level + correction factor  
 Margin = Limit – Emission Level

<b>Applicant:</b> Itronix Corporation	<b>Model:</b> IX325A775IWLBT	<b>FCC ID:</b> KBCIX325A775IWLBT	<b>IC ID:</b> 1943A-IX325e
<b>IX325 Rugged Tablet PC with internal Intel PRO2200BG 802.11b/g WLAN &amp; Well Green Dual Internal Antenna</b>			
2005 Celltech Labs Inc.	This document is not to be reproduced in whole or in part without the prior written permission of Celltech Labs Inc.		Page 57 of 59

	<b>Test Report Serial No.:</b>	060605KBC-T646-E15W	<b>Report Revision No.:</b>	Rev. 0
	<b>Test Date(s):</b>	4Jul05 - 20Jul05	<b>Report Issue Date:</b>	8Dec05
	<b>Test Standard(s):</b>	FCC 47 CFR §15.247	Industry Canada RSS-210 Issue 5	
	<b>Lab Registration(s):</b>	FCC Lab Reg. # 714830	Industry Canada Lab File #3874	

**G.10. PASS/FAIL**

In reference to the results outlined in H.9 the DUT passes the requirements as stated in the reference standards as follows:

The RF voltage measured in reference to ground on each of the power line conductors does not exceed the limits as outline in FCC 15.207.

The emission measured on Line 1 with the least margin to the limit measured with an AV detector at 3.579 MHz and a margin of 7.59 dB. The emission measured on Line 2 with the least margin to the limit was measured with a QP detector at 150 kHz with a margin of 12.55 dB.

**G.11. SIGN-OFF**

I attest to the accuracy of the data. All measurements reported herein were performed by me and are correct to the best of my knowledge and belief. I assume full responsibility for the completeness of these measurements.



---

Russell Pipe  
Senior Compliance Technologist  
Celltech Labs Inc.

20Jul05  
Date

<b>Applicant:</b>	Itronix Corporation	<b>Model:</b>	IX325A775IWLBT	<b>FCC ID:</b>	KBCIX325A775IWLBT	<b>IC ID:</b>	1943A-IX325e
<b>IX325 Rugged Tablet PC with internal Intel PRO2200BG 802.11b/g WLAN &amp; Well Green Dual Internal Antenna</b>							
2005 Celltech Labs Inc.	This document is not to be reproduced in whole or in part without the prior written permission of Celltech Labs Inc.						Page 58 of 59



	<b>Test Report Serial No.:</b>	060605KBC-T646-E15W	<b>Report Revision No.:</b>	Rev. 0
	<b>Test Date(s):</b>	4Jul05 - 20Jul05	<b>Report Issue Date:</b>	8Dec05
	<b>Test Standard(s):</b>	FCC 47 CFR §15.247	Industry Canada RSS-210 Issue 5	
	<b>Lab Registration(s):</b>	FCC Lab Reg. # 714830	Industry Canada Lab File #3874	

**END OF DOCUMENT**

<b>Applicant:</b>	Itronix Corporation	<b>Model:</b>	IX325A775IWLBT	<b>FCC ID:</b>	KBCIX325A775IWLBT	<b>IC ID:</b>	1943A-IX325e
<b>IX325 Rugged Tablet PC with internal Intel PRO2200BG 802.11b/g WLAN &amp; Well Green Dual Internal Antenna</b>							
2005 Celltech Labs Inc.	This document is not to be reproduced in whole or in part without the prior written permission of Celltech Labs Inc.						Page 59 of 59