

CLASS B VERIFICATION MEASUREMENTS

Under Title 47 CFR, Parts 15.107(a), 15.207(a) Conducted Emissions
and Parts 15.109(a), & & 15.109(a) Radiated Emissions

For

ITRONIX, Corporation

IX300 Tablet PC

March 8, 2004

Prepared By

**Spectrum Technology, Inc.
209 Dayton Street
Edmonds, WA 98020
425 771-4482**

VERIFICATION
TABLE OF CONTENTS

Table of Contents	2
Letter of Submittal and Compliance	3
TEST RESULTS AND DATA	
AC Conducted Emissions Part 15.107(a), 15.207(a)	4 - 6
Field Strength of Radiated Emissions Part 15.109 (a), 15.209(a)	7 - 9
Photographs of EUT setup	10 – 12
Open Field Site and Antenna/Equipment Orientation	13

March 8, 2004

Federal Communications Commission
Authorization and Standards Division
7435 Oakland Mills Rd.
Columbia, M.D. 21046

Re: Model: IX300 with AirCard 555, (WAN), WM168b-Molex, (WLAN), &
MUBTC2-TH, (Bluetooth)

Gentlemen:

Spectrum Technology Incorporated has tested this Digital Device containing two Intentional Radiators in accordance with the requirements contained in Part 15 of the CFR 47. To the best of my knowledge these tests were performed using measurement procedures consistent with ANSI C63.4 standard. The results demonstrate that the equipment complies with the published standard. We are unable to warrant against unpublished changes in requirements. The applicable rules are listed in the following test report.

The open area test site used for the radiated emissions measurements is located at Fluke Park II in Everett, Washington. The site information required by Part 2.98, measured in accordance with ANSI C63.4-2001, was most recently renewed with the FCC and accepted by the FCC Sampling and Measurements Branch in August 2001.

This site is also on file with Industry Canada for the performance of radiated emissions measurements. Test site information required by RSS-212, Issue 1 (provisional) was most recently renewed with IC in January 2002. The site file number is IC 2089.

Sincerely,

Rod Munro
President

TEST: CONDUCTED SPURIOUS EMISSIONS

Manufacturer: ITRONIX, Corporation.

Name: IX300 Tablet PC

Model: IX300 with AirCard 555, (WAN), WM168b-Molex, (WLAN), & MUBTC2-TH, (Bluetooth)

Setup:

The equipment under test (EUT) was set up in accordance with the provisions of ANSI C63.4-2001, Section 7, on a 1 X 1.5-meter non-conductive test table at our Edmonds, Washington facility. The tabletop is 80 cm above a 2.5 x 2-meter horizontal ground plane and 40 cm forward from a 2.25 X 2.4-meter vertical ground plane. The two ground planes are continuously grounded along the common seam. The two 50 ohm/ 50 uHy Line Impedance Stabilization Networks (LISN) are grounded to the horizontal ground plane. The EUT was placed in a typical operational arrangement following the 10-cm spacing as detailed in Section 6.2 and 11.2, and the power cord of the EUT plugged into the first LISN. The signal output of this LISN was fed to the Agilent E7405 EMC analyzer using a 9 kHz bandwidth, which served as the measuring instrument. The peripheral equipment, if any were powered from a separate LISN.

Discussion:

Measurements of the AC power line conducted spurious emissions were made with the ITRONIX IX300 inserted into the Desk Stand and set up in a representative system configuration. The Desk Stand is also the charging stand for the IX300, which can operate during the charging process. The frequency range from 150 kHz to 30 MHz was measured in detail. No modifications were made prior to the final compliance test.

Preliminary measurements were made as described in Section 7.2.3. The EUT was set up as an operational system. A Microsoft keyboard and a Microsoft optical mouse were connected to the USB ports on the Desk Stand. Measurements were made for the AC power input to the AC adapter Model: LSE9802A2060, which was connected to the Desk Stand and in turn powering the IX300. Excess I/O cable lengths were draped .5 m straight down behind the equipment then back up to the device used to terminate the line. The system cables were carefully tuned during the preliminary measurements on all frequencies of significance endeavoring to maximize the emissions observed. The test setup photos that follow detail the exact cable and equipment configuration for this test.

The ITRONIX Desk Stand with the IX300 inserted, was turned on and fully operational

while the batteries were charging. This unit was set up to transmit with all three transmitters active simultaneously during the measurements. During the preliminary measurements this IX300 was set to operate with simultaneously transmit on the first the low, then mid and finally the high channels respectively in multiple sets of measurements covering operational range of both transmitters. Note that no measurable change in the conducted emissions activity was observed when the transmitters were turned on or off or varied over the channel combinations listed below.

All of the following channel combinations were investigated during the preliminary measurements:

AC555			WLAN & Bluetooth	
Channel	Frequency MHz		Channel	Frequency MHz
128	824.2	and	1	2402
190	836.6	and	40	2441
251	848.8	and	79	2480
512	1850.2	And	1	2412
661	1880.0	And	40	2437
810	1909.8	And	79	2462

Final measurements were made as described in Section 7.2.3 while the EUT was fully functional as it would be in worst case (all three transmitters on) normal operation. The equipment had only one basic mode of operation, that being charging active. The final measurements were made with the AC555 transmitter set to 1880 MHz and the WLAN and Bluetooth Intentional Radiators set at 2412 MHz.

The following page shows the measured results of the EUT emission profile. The spectrum was observed from .15 to 30 MHz. The Class B average limits are: 56 to 46 dBuV from (0.15 to .5 MHz), 46 dBuV from (.5 to 5 MHz) and 50 dBuV from (5 to 30 MHz).

The conducted emissions were measured with Quasi-peak and Average detectors during the testing. The emissions results are reported for the "hot" and the "neutral" conductors, each with respect to ground at the power terminal. None of the emissions measured with the Quasi-peak detector exceeded the Average or QP limits. Further, none of the emissions measured with the Average emissions detector exceeded the Average limits.

Conclusion

The ITRONIX, Corporation IX300 when charging in the Desk Stand, met the conducted emissions requirements for Class B digital devices under Title 47 CFR, Para. 15.107(a), and for Intentional Radiators under 15.207(a).

TEST: CONDUCTED SPURIOUS EMISSIONS

Manufacturer: ITRONIX, Corporation.

Name: IX300 Tablet PC

Model: IX300 with AirCard 555, (WAN), WM168b-Molex, (WLAN), & MUBTC2-TH, (Bluetooth)

Part 15.107(a) and 15.207(a) the Class B average limits are: 56 to 46 dBuV from (0.15 to .5 MHz),
46 dBuV from (.5 to 5 MHz) and
50 dBuV from (5 to 30 MHz).

Note: Max level measured was 41.24 dBuV, with the average limit of 56 dBuV at 150 kHz the plot supports compliance with the current Part 15.107(a) limit.

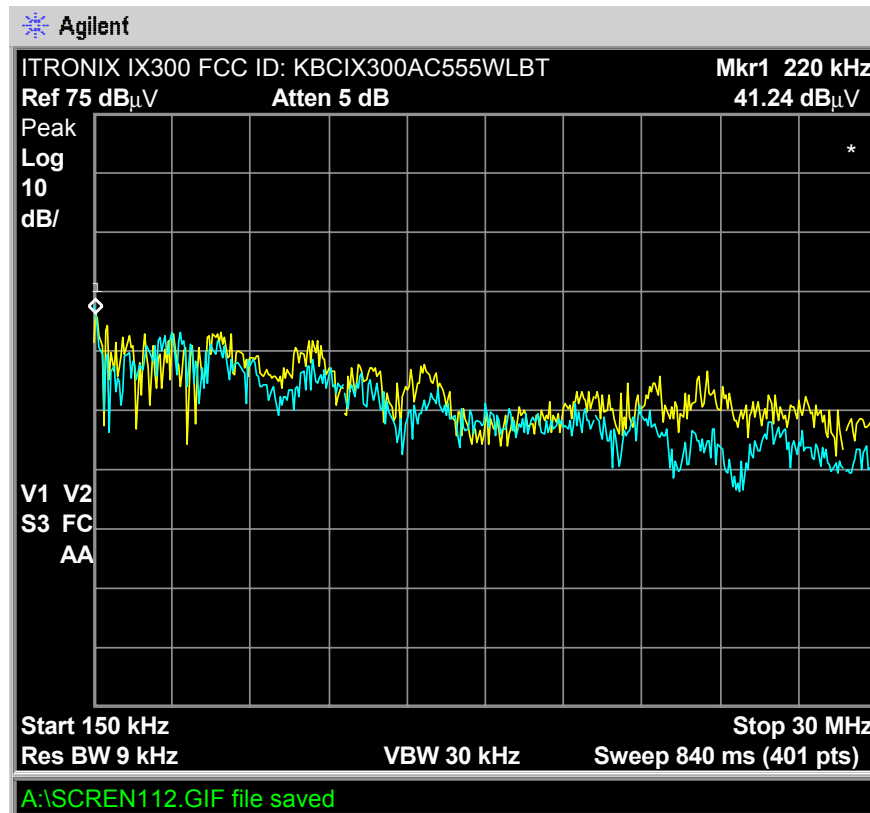

Note: ferrite located on AC adapter low voltage cord



TEST: FIELD STRENGTH OF RADIATED EMISSIONS

Manufacturer: ITRONIX, Corporation.
Name: IX300 Tablet PC
Model: IX300 with AirCard 555, (WAN), WM168b-Molex, (WLAN), & MUBTC2-TH, (Bluetooth)

Setup:

The equipment under test (EUT) was configured and operated in accordance with the applicable provisions of ANSI C63.4-2001, Section 6 and 8. The EUT was placed on a 80 cm height, 1 X 1.5 m non-metallic turntable that sits above the 15 X 30 meter ground plane at Spectrum's Open Area Test Site. There were no power cords as the device was battery operated. The antennas (dipoles, bi-conical or log-periodic) were mounted on a tower spaced at a 3 meters distance, and arranged for adjustment in height (1-4 meters) and V/H orientation to maximize the emissions levels when combined with turntable rotation of the EUT. An Agilent E7405 EMC analyzer, using 120 kHz bandwidth and a HP 8447F OPT H64 Amplifier were used for the measuring instrumentation.

Discussion:

Measurements of the radiated spurious emissions were made with the ITRONIX IX300 inserted into the Desk Stand and set up in a representative system configuration. The Desk Stand is also the charging stand for the IX300, which can operate during the charging process. The frequency range from 30 to 1000 MHz was measured in detail. No modifications were made prior to the final compliance test.

Preliminary measurements were made as described in Section 8.3.1.1. The EUT was set up as an operational system. A Microsoft keyboard and a Microsoft mouse were connected to the two USB ports on the Desk Stand. Excess I/O cable lengths were draped .5 m straight down behind the equipment then back up to the device used to terminate the line. The system cables were carefully tuned during the preliminary measurements on all frequencies of significance endeavoring to maximize the emissions observed.

During the preliminary measurements the IX300 was set up at the OATS facility with the receive antenna in close proximity, about 1.0 meter distance. The IX300 was operated on the frequencies listed following in an attempt to identify measurable emission frequencies. The test setup photos that follow detail the exact cable and equipment configuration for this test. During the preliminary measurements this IX300 was set to operate with simultaneously transmit on the first the low, then mid and finally the high channels respectively in multiple sets of measurements covering operational range of both transmitters. Note that no measurable change in the conducted emissions activity was observed when the transmitters were turned on or off or varied over the channel

combinations listed below.

All of the following channel combinations were investigated during the preliminary measurements:

AC555			WLAN & Bluetooth	
Channel	Frequency MHz		Channel	Frequency MHz
128	824.2	and	1	2402
190	836.6	and	40	2441
251	848.8	and	79	2480
512	1850.2	and	1	2412
661	1880.0	and	40	2437
810	1909.8	and	79	2462

Preliminary measurements were made while the system was investigated operating in the following modes:

- 1) IX300 operating digital device active only, no transmitters turned on.
- 2) IX300 operating with the Bluetooth transmitter on low, mid and hi channel.
- 3) IX300 operating with the AirCard 555 transmitting on the high mid and low channels in the Cellular and PCS bands.

For the final measurements, the IX300 inserted in the ITRONIX Desk Stand, turned on and fully operational while the battery was charging. This unit was set up to transmit with all three transmitters active simultaneously during the measurements.

The final OATS test configuration is shown in photographs included in this report. Final digital device measurements were made from 30 - 1000 MHz as specified in Section 8.3.1.2 and were made at three meters.

Conclusion:

The ITRONIX, Inc. IX300 when operated as discussed above, meets the radiated emissions requirements for a receivers and Class B digital devices under Title 47 CFR, Parts 15.109(a) and 15.209(a).

EXHIBIT 6 TEST: FIELD STRENGTH OF SPURIOUS RADIATED EMISSIONS

FCC ID: KBCIX300AC555WLBT

Applicant: ITRONIX Corp.

Model: IX300 with AirCard 555, (WAN), WM168b- Molex, (WLAN), & MUBTC2-TH, (Bluetooth)

Minimum Standard Specified: Part 15.109(a), 15.209(a)

Frequency Range Observed: 30 to 1 GHz

Date: 2/12/04

Test Setup: See block diagram and photos following.

NOTE: Simultaneous co-location transmit on the identical low, mid & hi freq. with the WM168b-Molex, (WLAN) and the MUBTC2-TH, (Bluetooth), intentional radiators. AC555 was also transmitting on it's low, mid and high channels respectively (1850.2, 1880, 1909.8 MHz). The AC555 transmitter maximum power output was fed to a resistive coaxial termination.

RADIATED SPURIOUS EMISSIONS									
Frequency GHz	Max. SA Rdg. dBu/V	Ant. Vert. or Horz.	Peak or Average Detector	Antenna Factor dB	Cable loss dB	Amp Gain	Corrected Reading dBuV/m	Limit dBu/V	Margin in dB below LIMIT
128.90	19.70	H	Peak	8.6	2.38	-inc.-	30.68	43.5	12.82
128.90	16.74	V	Peak	8.6	2.38	-inc.-	27.72	43.5	15.80
130.00	15.31	H	Peak	8.6	2.38	-inc.-	26.29	43.5	17.21
130.00	12.85	V	Peak	8.6	2.38	-inc.-	23.83	43.5	19.67
132.54*	25.99	H	Peak	8.7	2.40	-inc.-	37.09	43.5	6.41
132.54*	19.86	V	Peak	8.7	2.40	-inc.-	30.96	43.5	12.54
133.23*	25.82	H	Peak	8.7	2.40	-inc.-	36.92	43.5	6.58
133.23*	19.72	V	Peak	8.7	2.40	-inc.-	30.82	43.5	12.68
171.26	16.18	H	Peak	10.1	2.68	-inc.-	28.96	43.5	14.54
171.26	13.32	V	Peak	10.1	2.68	-inc.-	26.10	43.5	17.40
266.00	13.61	H	Peak	12.6	3.15	-inc.-	29.36	46.0	16.64
266.00	10.50	V	Peak	12.6	3.15	-inc.-	26.25	46.0	17.25
298.99	10.21	H	Peak	13.9	3.30	-inc.-	27.41	46.0	18.59
298.99	18.26	V	Peak	13.9	3.30	-inc.-	35.46	46.0	10.54
397.50*	21.47	H	Peak	16.1	3.79	-inc.-	41.36	46.0	4.64
397.50*	21.60	V	Peak	16.1	3.79	-inc.-	41.49	46.0	4.51
397.75*	21.24	H	Peak	16.1	3.79	-inc.-	41.13	46.0	4.87
397.75*	21.80	V	Peak	16.1	3.79	-inc.-	41.69	46.0	4.31
480.00	21.31	H	Peak	17.7	4.00	-inc.-	43.01	46.0	2.99
480.00	21.72	V	Peak	17.7	4.00	-inc.-	43.42	46.0	2.58
* Broadband emission upper and lower peak recorded									

EUT Radiated Emissions Setup

The EUT was tested in three mutually orthogonal planes during preliminary measurements with the antenna within 1 meter. The digital device emissions levels were low regardless of the position. The unit was tested in its desk top dock and charging fixture on the table as a representative worst case position for stationary intended use.

Front View with software for all three active transmitters visible



Antenna was removed and the output terminated to a load during testing.

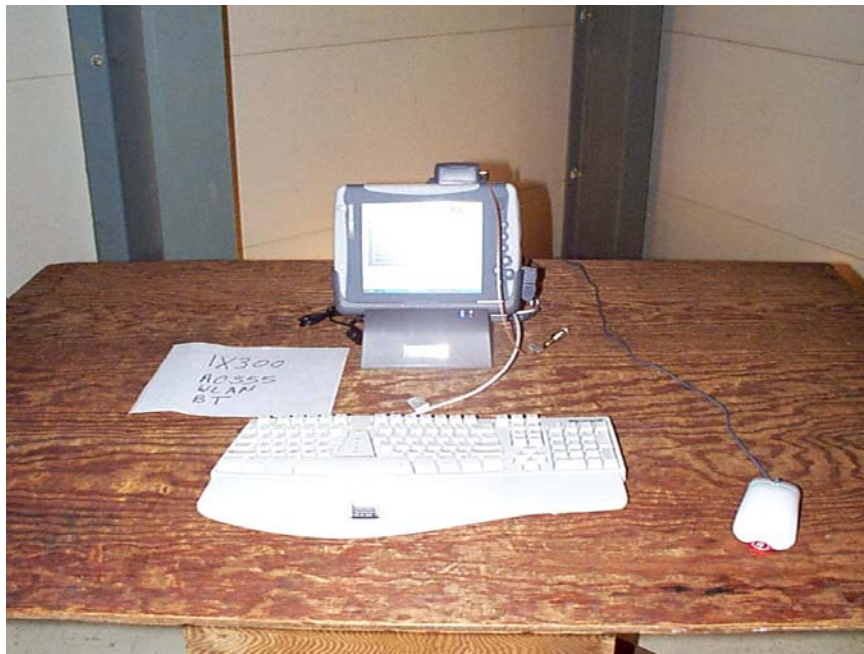

Termination of AC555 RF output



Rear View



EUT Conducted Emissions Setup

Front View



Left Side View



EXHIBIT VII - Test Set-Up Procedures

BLOCK DIAGRAM #1

Radiated Spurious Emissions Test Set Up

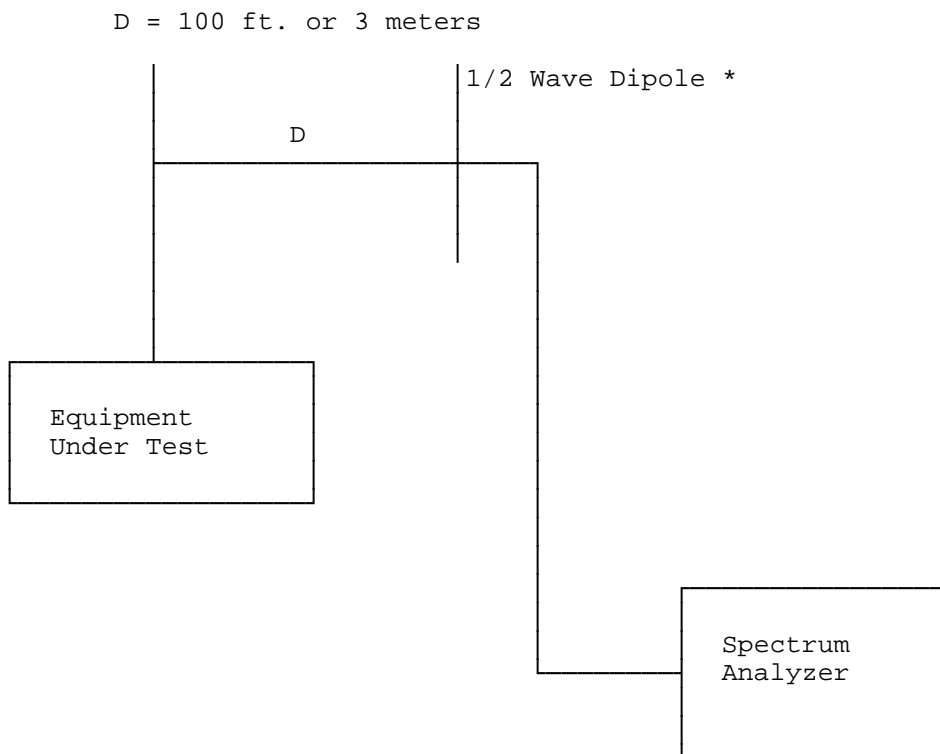

See Equipment List for Models

- * 1/2 Wave Dipole 30-1000 MHz or Bi-Conilog
- Dual Ridged Guide Antenna or Broadband Log Periodic 1-18 GHz
- Standard Gain Horn 18 – 26.5 GHz

End of Report