

<b>Test Report S/N</b>	052604-515/516KBC
<b>Test Date(s)</b>	28Jun04 - 29Jul04
<b>Test Type</b>	FCC Part 15.247

**EMC TEST REPORT**  
FOR THE  
**MODEL IX260+ RUGGED LAPTOP PC**  
WITH  
**INTEL PRO 2200BG MINI-PCI 2.4 GHz DSSS WLAN CARD**  
AND  
**INTERNAL ANTENNA**

TRSN 052604-515/516KBC  
Issue 2.0

**Celltech Compliance Testing & Engineering Lab**  
**(Celltech Labs Inc.)**  
**1955 Moss Court**  
**Kelowna, BC**  
**Canada**  
**V1Y 9L3**

**July 29, 2004**

**(In accordance with FCC Part 15.247)**



<b>Test Report S/N:</b>	052604-515/516KBC
<b>Test Date(s):</b>	28Jun04 - 29Jul04
<b>Test Type:</b>	FCC Part 15.247

## DECLARATION OF COMPLIANCE

<p><b>Test Lab</b></p> <p><b>CELLTECH LABS INC.</b>          Testing and Engineering Services          1955 Moss Court          Kelowna, B.C.          Canada V1Y 9L3</p> <p><b>Phone:</b> 250-448-7047  <b>Fax:</b> 250-448-7048  <b>e-mail:</b> info@celltechlabs.com  <b>web site:</b> www.celltechlabs.com</p>	<p><b>Applicant Information</b></p> <p><b>ITRONIX CORPORATION</b>          801 South Stevens Street          Spokane, WA 99210          USA</p>
<p><b>Laboratory Registration No.(s):</b> FCC: 714830 IC IC 3874</p>	
<p><b>Rule Part(s):</b> FCC: <b>§15.247; §2.1091; §1.1310</b></p>	
<p><b>Device Classification:</b> FCC: Digital Transmission System (DTS)</p>	
<p><b>Device Identification:</b> FCC ID: KBCIX260PRO2200</p>	
<p><b>DUT Description:</b></p> <p><b>Model:</b> IX260+</p> <p><b>Device Type:</b> Rugged Laptop PC with Intel Pro 2200BG Mini-PCI 2.4GHz DSSS WLAN Card &amp; Internal Antenna</p> <p><b>Tx Frequency Range:</b> 2412 - 2462 MHz</p> <p><b>Max. RF Output Power:</b> 17.48 dBm Peak Conducted - 802.11b          16.15 dBm Peak Conducted - 802.11g</p> <p><b>Modulation(s):</b> DBPSK, DQPSK, CCK</p> <p><b>Antenna Type:</b> RangeStar P/N: 100929 Dual Internal Surface-Mount (WLAN)</p> <p><b>Power Supply:</b> 90 Watt AC Power Adapter</p>	

This wireless portable device has demonstrated to be in compliance with the applicable technical standards as indicated in the measurement report and was tested in accordance with the measurement procedures specified in FCC 47 CFR Part 15.247.

I attest to the accuracy of the data. All measurements reported herein were performed by me or were under my supervision and are correct to the best of my knowledge and belief. I assume full responsibility for the completeness of these measurements and vouch for the qualifications of all persons taking them.

This test report shall not be reproduced partially, or in full, without the prior written approval of Celltech Labs Inc. The results and statements contained in this report pertain only to the device(s) evaluated.

**Russell Pipe**  
 Senior Compliance Technologist  
 Celltech Labs Inc.

**Duane M. Friesen, C.E.T.**  
 EMC Manager  
 Celltech Labs Inc.

Itronix Corporation	FCC ID:	KBCIX260PRO2200	Model:	IX260+ with Intel Pro 2200BG WLAN
<b>Rugged Laptop PC with internal WLAN Mini-PCI Card (802.11b/g)</b>				
2004 Celltech Labs Inc	This document is not to be reproduced in whole or in part without the written permission of Celltech Labs Inc.			2 of 84

<b>Test Report S/N:</b>	052604-515/516KBC
<b>Test Date(s):</b>	28Jun04 - 29Jul04
<b>Test Type:</b>	FCC Part 15.247

## TABLE OF CONTENTS

1.0 SCOPE .....	7
2.0 REFERENCES .....	7
2.1 Normative References .....	7
3.0 TERMS AND DEFINITIONS .....	8
4.0 FACILITIES AND ACCREDITATIONS .....	9
5.0 GENERAL INFORMATION .....	9
5.1 Applicant Information .....	9
5.2 DUT Description.....	9
5.3 Cable Descriptions.....	10
5.4 Support Equipment .....	10
5.5 Clock Frequencies .....	11
5.6 Mode(s) of Operation Tested.....	11
5.7 Configuration Description .....	12
6.0 PASS/FAIL CRITERIA.....	12
APPENDIX.....	13
Appendix A - DUT Photographs .....	14
Appendix B - 6 dB Bandwidth Measurement.....	19
Appendix C - Peak Conducted Power Measurement.....	28
Appendix D - Maximum Permissible Exposure Calculation.....	31
Appendix E - Radiated Spurious Emissions Measurement.....	34
Appendix F - Restricted Band Emissions Measurement .....	53
Appendix G - Peak Power Spectral Density Measurement.....	68
Appendix H - Conducted Powerline Emissions Measurement .....	77
END OF DOCUMENT.....	84

<b>Test Report S/N:</b>	052604-515/516KBC
<b>Test Date(s):</b>	28Jun04 - 29Jul04
<b>Test Type:</b>	FCC Part 15.247

## FIGURES

Figure B-1 – Setup Drawing.....	20
Figure C-1 – Setup Drawing .....	29
Figure E-1 – Setup Drawing.....	35
Figure F-1 – Setup Drawing.....	55
Figure G-1 – Setup Drawing .....	69
Figure H-1 – Setup Drawing .....	80

## PLOTS

Plot B-1 - 6 dB Bandwidth Low Channel (802.11b).....	21
Plot B-2 - 6 dB Bandwidth Mid Channel (802.11b).....	22
Plot B-3 - 6 dB Bandwidth High Channel (802.11b).....	23
Plot B-4 - 6 dB Bandwidth Low Channel (802.11g).....	24
Plot B-5 - 6 dB Bandwidth Mid Channel (802.11g).....	25
Plot B-6 - 6 dB Bandwidth High Channel (802.11g).....	26
Plot G-1 - PPSD Low Channel (802.11b).....	70
Plot G-2 - PPSD Mid Channel (802.11b).....	71
Plot G-3 - PPSD High Channel (802.11b).....	72
Plot G-4 - PPSD Low Channel (802.11g).....	73
Plot G-5 - PPSD Mid Channel (802.11g).....	74
Plot G-6 - PPSD High Channel (802.11g).....	75
Plot H-1 - Line 1 Peak Conducted Powerline Emissions.....	82
Plot H-2 - Line 2 Peak Conducted Powerline Emissions.....	82

<b>Test Report S/N:</b>	052604-515/516KBC
<b>Test Date(s):</b>	28Jun04 - 29Jul04
<b>Test Type:</b>	FCC Part 15.247

## PHOTOGRAPHS

Photograph A-1 - Front of Open IX260+ Laptop PC.....	14
Photograph A-2 - Back of Open IX260+ Laptop PC.....	14
Photograph A-3 - Left Side of Open IX260+ Laptop PC.....	14
Photograph A-4 - Right Side of Open IX260+ Laptop PC.....	14
Photograph A-5 - Back of Closed IX260+ Laptop PC.....	15
Photograph A-6 - Back of Battery Pack.....	15
Photograph A-7 - Front of Battery Pack.....	15
Photograph A-8 - Battery Compartment of IX260+ Laptop PC.....	15
Photograph A-9 - Bottom of IX260+ Laptop PC – Location of Intel Pro 2200BG Mini-PCI WLAN Card.....	16
Photograph A-10 - Front of Intel Pro 2200BG Mini-PCI WLAN Card in IX260+ Laptop PC.....	16
Photograph A-11 - Front of Intel Pro 2200BG Mini-PCI WLAN Card.....	16
Photograph A-12 - Front of Intel Pro 2200BG Mini-PCI WLAN Card without Label.....	17
Photograph A-13 - Back of Intel Pro 2200BG Mini-PCI WLAN Card without Label.....	17
Photograph A-14 - Front of Intel Pro 2200BG Mini-PCI WLAN Card with Shielding Removed.....	17
Photograph A-15 - Back of Intel Pro 2200BG Mini-PCI WLAN Card with Label.....	17
Photograph A-16 - Back of the IX260+ Laptop PC LCD with the Cover Removed.....	18
Photograph A-17 - Distance Between Integrated WLAN Antennas.....	18
Photograph E-1 - Horizontal Polarization (30MHz – 1 GHz).....	36
Photograph E-2 - Vertical Polarization (30MHz – 1 GHz).....	36
Photograph E-3 - Front of Radiated Emission Configuration.....	36
Photograph E-4 - Back of Radiated Emission Configuration.....	36
Photograph F-1 - Horizontal Polarization (30MHz – 1 GHz).....	56
Photograph F-2 - Vertical Polarization (30MHz – 1 GHz).....	56
Photograph F-3 - Front of Radiated Emission Configuration.....	56
Photograph F-4 - Back of Radiated Emission Configuration.....	56
Photograph H-1 – AC Powerline Conducted Emission Configuration.....	79
Photograph H-2 – AC Powerline Conducted Emission Cable Placement.....	79

<b>Test Report S/N:</b>	052604-515/516KBC
<b>Test Date(s):</b>	28Jun04 - 29Jul04
<b>Test Type:</b>	FCC Part 15.247

### TEST SUMMARY



**Referenced Standard:** CFR Title 47 Part 15

<u>Appendix</u>	<u>Test Description</u>	<u>Procedure Reference</u>	<u>Limit Reference</u>	<u>Test Start Date</u>	<u>Test End Date</u>	<u>Result</u>
B	6 dB Bandwidth	FCC 97-114	§15.247(2)	26Jul04	26Jul04	Pass
C	Peak Conducted Power	FCC 97-114	§15.247 (b) (3)	28Jun04	26Jul04	Pass
D	Maximum Permissible Exposure	FCC CFR 47 § 2.1091 IEEE Std C95.1-1992	§1.1310 Table 1 (b)	28Jun04	28Jun04	Pass
E	Radiated Spurious Emissions	FCC 97-114	§15.247(c)	26Jul04	29Jul04	Pass
F	Restricted Band Emissions	FCC 97-114	§15.205 (a), (b) §15.209 (a)	26Jul04	29Jul04	Pass
G	Peak Power Spectral Density	FCC 97-114	§15.247(d)	27Jul04	27Jul04	Pass
H	Powerline Conducted Emissions	ANSI C63.4	§15.207	29Jun04	05Jul04	Pass

### REVISION LOG

<u>Issue</u>	<u>Description</u>	<u>Implemented By</u>	<u>Implementation Date</u>
1.0	Initial Release	Jon Hughes	08Jul04
2.0	Updated Release	Jon Hughes	29Jul04

### SIGNATORIES

<b>Prepared By:</b>		July 29, 2004
<b>Name/Title</b>	Russell Pipe / Senior Compliance Technologist	<b>Date</b>
<b>Reviewed By:</b>		July 29, 2004
<b>Name/Title</b>	Jon Hughes / General Manager	<b>Date</b>
<b>Approved By:</b>		July 29, 2004
<b>Name/Title</b>	Duane M. Friesen, C.E.T. / EMC Manager	<b>Date</b>

<b>Test Report S/N:</b>	052604-515/516KBC
<b>Test Date(s):</b>	28Jun04 - 29Jul04
<b>Test Type:</b>	FCC Part 15.247

## 1.0 SCOPE

This report outlines the measurements made and results collected during the Electromagnetic emissions testing of Itronix Corporation IX260+ Rugged Laptop PC with internal Intel Pro 2200BG Mini-PCI WLAN (802.11b/g). The results were applied against the EMC requirements and limits outlined in the technical rules and regulations set forth in the Federal Communication Commission Code of Federal Regulations Title 47 Part 15 subpart J.

## 2.0 REFERENCES

### 2.1 Normative References

ANSI/ISO 17025:1999	General Requirements for competence of testing and calibration laboratories
CFR Title 47 Part 2:2003	Code of Federal Regulations Title 47: Telecommunication Part 2: Frequency Allocations and Radio Treaty Matters; General Rules and Regulations
CFR Title 47 Part 15:2003	Code of Federal Regulations Title 47: Telecommunication Part 15: Radio Frequency Devices

<b>Test Report S/N:</b>	052604-515/516KBC
<b>Test Date(s):</b>	28Jun04 - 29Jul04
<b>Test Type:</b>	FCC Part 15.247

### 3.0 TERMS AND DEFINITIONS

AVG	Average
CFR	Code of Federal Regulations
dB	decibel
dBm	dB referenced to 1 mW
dBuV	dB referenced to 1 uV
DUT	Device under Test
dBc	dB down from carrier
EBW	Emission Bandwidth
EMC	Electromagnetic Compatibility
FCC	Federal Communication Commission
HP	Hewlett Packard
HPF	High Pass Filter
Hpol	Horizontal Polarization
IC	Industry Canada
kHz	kilohertz
LNA	Low Noise Amplifier
m	meter
MHz	Megahertz
Mbps	megabits per second
na	not applicable
n/a	not available
PK	Peak
PPSD	Peak Power Spectral Density
QP	Quasi-peak
RBW	Resolution Bandwidth
R&S	Rohde & Schwarz
RSS	Radio Standard Specification
SA	Spectrum Analyzer
VBW	Video Bandwidth
Vpol	Vertical Polarization



<b>Test Report S/N:</b>	052604-515/516KBC
<b>Test Date(s):</b>	28Jun04 - 29Jul04
<b>Test Type:</b>	FCC Part 15.247

#### 4.0 FACILITIES AND ACCREDITATIONS

The facilities used in collecting the test results outlined in this report are located at 1955 Moss Court, Kelowna, British Columbia, Canada, V1Y 9L3. The radiated and conducted emissions sites conform with the requirements set forth in ANSI C63.4 and are filed and listed with the FCC under Registration Number 714830 and Industry Canada under File Number IC 3874.

#### 5.0 GENERAL INFORMATION

##### 5.1 Applicant Information

<b>Company Name:</b>	<b>Itronix Corporation</b>
<b>Address:</b>	801 South Stevens Street Spokane, WA 99210 USA

##### 5.2 DUT Description

The DUT consisted of Model IX260+ Rugged Laptop PC with Intel Pro 2200BG 2.4 GHz DSSS WLAN Mini-PCI Card installed in the mini-pci slot, and a Dual Internal Surface-Mount (WLAN) Antenna installed in the LCD display. Photographs of the DUT placement and construction are shown in Appendix A.

<b>Name:</b>	Rugged Laptop PC		
<b>Model:</b>	IX260+		
<b>Serial Number:</b>	ZZGEG4112ZZ9777		
<b>Device Identification:</b>	<b>FCC ID:</b>	KBCIX260PRO2200	
<b>Power Source:</b>	Delta Electronics Model ADP-90AB Rev B 90 Watt AC-DC power supply		

<b>Name:</b>	2.4GHz DSSS WLAN Mini-PCI Card		
<b>Model:</b>	Intel Pro2200BG		
<b>Serial Number:</b>	06036C074ADC54906006		
<b>Rule Part(s):</b>	<b>FCC:</b>	§15.247; §2.1091; §1.1310	
<b>Device Classification:</b>	<b>FCC:</b>	Digital Transmission System (DTS)	
<b>Power Source:</b>	Powered from the internal PC power supply		

<b>Name:</b>	Dual Internal Surface-Mount (WLAN) Antenna		
<b>Model:</b>	RangeStar P/N: 100929		
<b>Gain:</b>	4.5 dBi		

<b>Test Report S/N:</b>	052604-515/516KBC
<b>Test Date(s):</b>	28Jun04 - 29Jul04
<b>Test Type:</b>	FCC Part 15.247

### 5.3 Cable Descriptions

ROUTING		Length m	Model	Terminations		Shield Type	Shield Termination		Suppression
From	To			End 1	End 2		End 1	End 2	
PC Fire Wire Port	Unterminated	1.0	Copartner E119932	IEEE-1528	Fire wire	n/a	n/a	n/a	None
PC modem port	Unterminated	1.0	n/a	RJ-11	RJ-11	None	na	na	None

### 5.4 Support Equipment

The following equipment was used in support of the DUT.

CO-LOCATED SUPPORT EQUIPMENT LIST		
MANUFACTURER	MODEL	DESCRIPTION
D-Link	DE-809TC/	Ethernet hub
YNG YUH	YP-040	Hub power supply
MLi	699	Speakers
Polk Audio	n/a	Speaker microphone
DeLorme	Tripmate	GPS Receiver
Intel	CS-430	Camera
Logitech	M-S34	Mouse

<b>Test Report S/N:</b>	052604-515/516KBC
<b>Test Date(s):</b>	28Jun04 - 29Jul04
<b>Test Type:</b>	FCC Part 15.247

## 5.5 Clock Frequencies

### 5.5.1 DUT Clock Frequencies

<b>Name:</b>	Rugged Laptop PC
<b>Clocks:</b>	1.6 GHz processor
<b>Name:</b>	2.4GHz DSSS WLAN Mini-PCI Card (802.11b/g)
<b>Clocks:</b>	40 MHz, f <sub>o</sub> /1.5 (Low – 1608.000 MHz, Mid – 1624.667 MHz, High – 1641.333 MHz)
<b>Name:</b>	Dual Internal Surface-Mount (WLAN) Antenna
<b>Clocks:</b>	None

### 5.5.2 On-Site Clock Frequencies

<b>Name:</b>	Peripherals
<b>Clocks:</b>	n/a

## 5.6 Mode(s) of Operation Tested

Customer supplied software was used to place the WLAN card in the appropriate mode, channel and power level for the specific measurement.

<b>TX Frequency Range:</b>	2412 – 2462 MHz Ch. 1 (2412 MHz), Ch. 6 (2437 MHz) & Ch. 11 (2462 MHz) measured unless otherwise noted)	
<b>Software Power Gain Settings:</b>	802.11b set to 29 802.11g set to 24.5	
<b>RF Peak Conducted Output Power Tested</b>	802.11b 2412 MHz(1 Mbps) = 16.28 dBm 802.11b 2437 MHz(1 Mbps) = 16.79 dBm 802.11b 2462 MHz(1 Mbps) = 17.48 dBm	802.11g 2412 MHz(6 Mbps) = 15.14 dBm 802.11g 2437 MHz(6 Mbps) = 15.55 dBm 802.11g 2462 MHz(6 Mbps) = 16.15 dBm
<b>Modes / Data Rates Tested:</b>	802.11b (1, 5.5, 11 Mbps checked in prescan) (1 Mbps determined to be worse case and used unless otherwise noted)	
	802.11g (6, 36, 54 Mbps checked in prescan) (6 Mbps determined to be worse case and used unless otherwise noted)	
<b>Battery Type(s)</b>	11.1V Lithium-Ion, 6.0Ah (Model: A2121-2)	
<b>Modulation Type:</b>	OFDM with BPSK, QPSK, 16QAM, 64QAM, DBPSK, DQPSK, CCK	

### 5.6.1 DUT Exercising Software Description

The DUT was configured and exercised using customer supplied test software that allowed an operator to set the parameters of the WLAN operation. The settings used are described in each appendix. Unless otherwise noted the power gain settings were set for 29 for 802.11b and 24.5 dB for 802.11g and the data rate set for 1 Mbps for 802.11b and 6 Mbps for 802.11g.

<b>Itronix Corporation</b>	<b>FCC ID:</b>	<b>KBCIX260PRO2200</b>	<b>Model:</b>	<b>IX260+ with Intel Pro 2200BG WLAN</b>
2004 Celltech Labs Inc	<b>Rugged Laptop PC with internal WLAN Mini-PCI Card (802.11b/g)</b>			11 of 84
This document is not to be reproduced in whole or in part without the written permission of Celltech Labs Inc.				

<b>Test Report S/N:</b>	052604-515/516KBC
<b>Test Date(s):</b>	28Jun04 - 29Jul04
<b>Test Type:</b>	FCC Part 15.247

### 5.7 Configuration Description

The DUT was configured, as described by the client as being representative of what would be delivered to a final customer. More specific details may be included in each appendix.

#### 5.7.1 Configuration Justification

The DUT was tested in a configuration described by the client as being worse case but typical of normal use.

Prescan measurements were made with the WLAN in each of the two available modes (b & g), lowest, medium and highest bit rates and each of the lowest, highest and mid-band frequencies. From this preliminary data, it was determined that Channel 11, Mode b Rate 1 Mbps resulted in the highest emissions. When a measurement of Mode g was required, its data rate was set for a worse case setting of 6 Mbps. Unless otherwise specified in the applicable appendices, these settings were used for the measurements described in this report.

### 6.0 PASS/FAIL CRITERIA

Unless otherwise noted in the Appendices, the pass/fail criteria is the limit set forth in the reference standards. A DUT is considered to have passed the requirements, if the data collected during the described measurement procedure is less than or equal to the specified limits as defined. The pass/fail statements made in this report only apply to the unit tested.

<b>Test Report S/N:</b>	052604-515/516KBC
<b>Test Date(s):</b>	28Jun04 - 29Jul04
<b>Test Type:</b>	FCC Part 15.247

## APPENDIX

<b>Itronix Corporation</b>	<b>FCC ID:</b>	<b>KBCIX260PRO2200</b>	<b>Model:</b>	<b>IX260+ with Intel Pro 2200BG WLAN</b>
2004 Celltech Labs Inc	<b>Rugged Laptop PC with internal WLAN Mini-PCI Card (802.11b/g)</b>			13 of 84
This document is not to be reproduced in whole or in part without the written permission of Celltech Labs Inc.				

<b>Test Report S/N:</b>	052604-515/516KBC
<b>Test Date(s):</b>	28Jun04 - 29Jul04
<b>Test Type:</b>	FCC Part 15.247

### Appendix A - DUT Photographs

Photograph A-1 - Front of Open IX260+ Laptop PC



Photograph A-2 - Back of Open IX260+ Laptop PC



Photograph A-3 - Left Side of Open IX260+ Laptop PC



Photograph A-4 - Right Side of Open IX260+ Laptop PC



<b>Test Report S/N:</b>	052604-515/516KBC
<b>Test Date(s):</b>	28Jun04 - 29Jul04
<b>Test Type:</b>	FCC Part 15.247

Photograph A-5 - Back of Closed IX260+ Laptop PC



Photograph A-6 - Back of Battery Pack

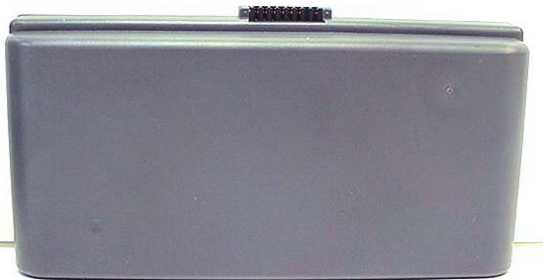

Photograph A-7 - Front of Battery Pack



Photograph A-8 - Battery Compartment of IX260+ Laptop PC



<b>Test Report S/N:</b>	052604-515/516KBC
<b>Test Date(s):</b>	28Jun04 - 29Jul04
<b>Test Type:</b>	FCC Part 15.247

Photograph A-9 - Bottom of IX260+ Laptop PC – Location of Intel Pro 2200BG Mini-PCI WLAN Card



Photograph A-10 - Front of Intel Pro 2200BG Mini-PCI WLAN Card in IX260+ Laptop PC



Photograph A-11 - Front of Intel Pro 2200BG Mini-PCI WLAN Card



<b>Itronix Corporation</b>	<b>FCC ID:</b>	<b>KBCIX260PRO2200</b>	<b>Model:</b>	<b>IX260+ with Intel Pro 2200BG WLAN</b>
2004 Celltech Labs Inc	<b>Rugged Laptop PC with internal WLAN Mini-PCI Card (802.11b/g)</b>			16 of 84
This document is not to be reproduced in whole or in part without the written permission of Celltech Labs Inc.				



<b>Test Report S/N:</b>	052604-515/516KBC
<b>Test Date(s):</b>	28Jun04 - 29Jul04
<b>Test Type:</b>	FCC Part 15.247

Photograph A-12 - Front of Intel Pro 2200BG Mini-PCI WLAN Card without Label

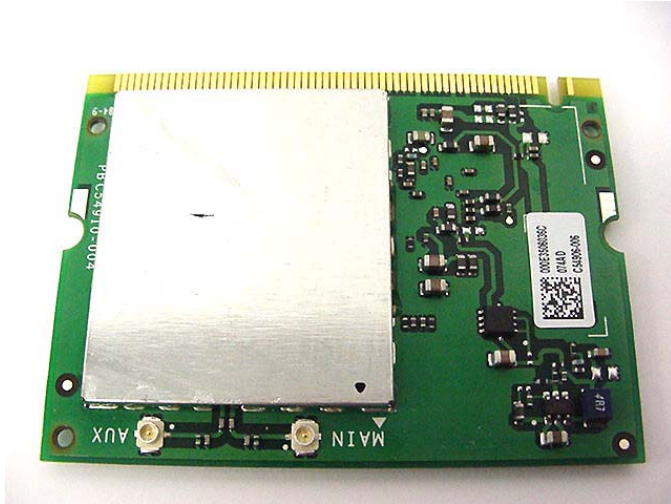

Photograph A-13 - Back of Intel Pro 2200BG Mini-PCI WLAN Card without Label

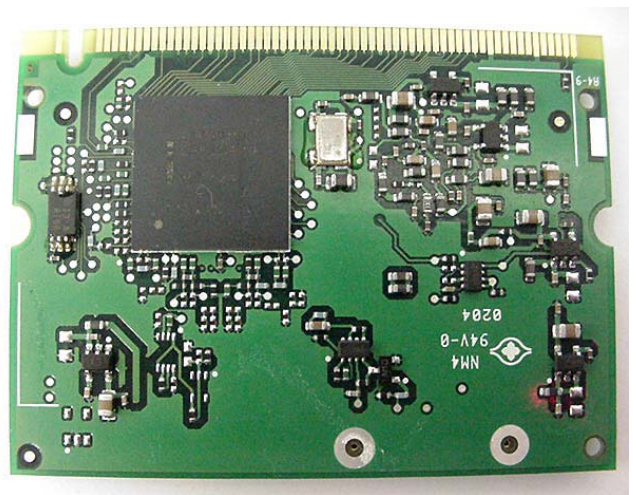

Photograph A-14 - Front of Intel Pro 2200BG Mini-PCI WLAN Card with Shielding Removed



Photograph A-15 - Back of Intel Pro 2200BG Mini-PCI WLAN Card with Label



Test Report S/N:	052604-515/516KBC
Test Date(s):	28Jun04 - 29Jul04
Test Type:	FCC Part 15.247

Photograph A-16 - Back of the IX260+ Laptop PC LCD with the Cover Removed

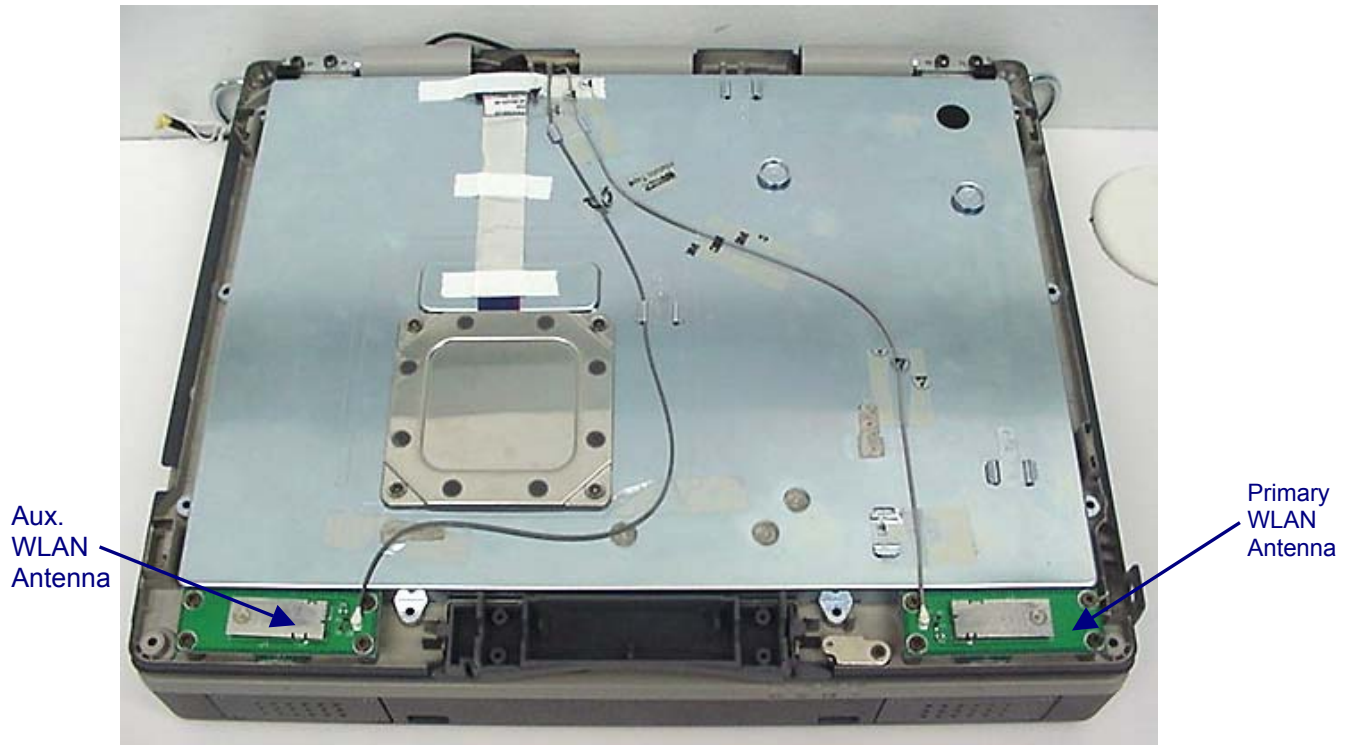

Photograph A-17 - Distance Between Integrated WLAN Antennas

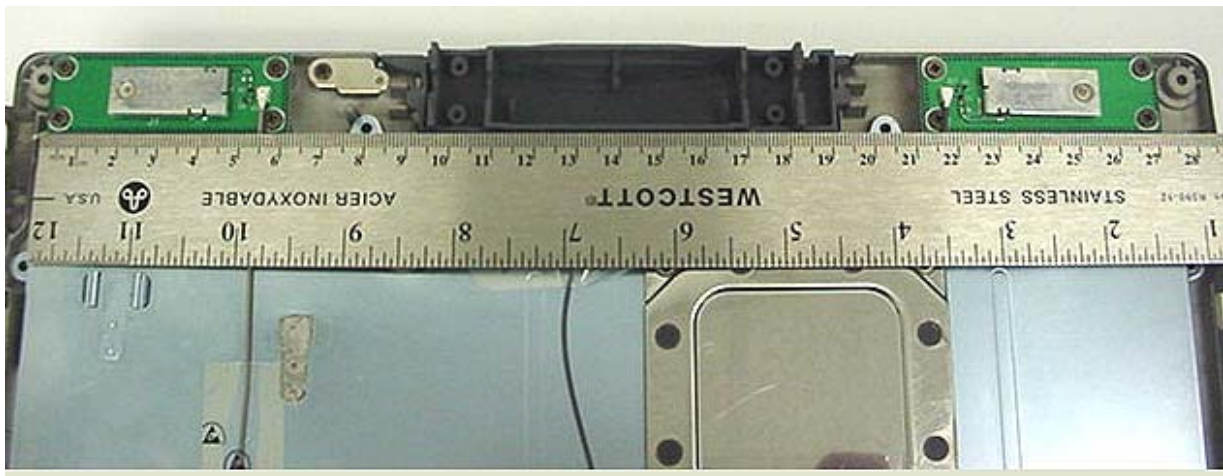

<b>Test Report S/N:</b>	052604-515/516KBC
<b>Test Date(s):</b>	28Jun04 - 29Jul04
<b>Test Type:</b>	FCC Part 15.247

### Appendix B - 6 dB Bandwidth Measurement

B.1. REFERENCES	
<b>Normative Reference Standard</b>	FCC CFR 47 §15.247 (2)
<b>Procedure Reference</b>	FCC 97-114

B.2. LIMITS	
B.2.1. FCC CFR 47	
FCC CFR 47 §15.247	(2) <i>Systems using digital modulation techniques may operate in the 902 – 928, 2400 – 2483.5 MHz, and 5725 – 5850 MHz bands. The minimum 6 dB bandwidth shall be at least 500 kHz</i>

B.3. ENVIRONMENTAL CONDITIONS	
<b>Temperature</b>	25.2 +/- 2 °C
<b>Humidity</b>	35 +/- 2 %
<b>Barometric Pressure</b>	96.34 kPa

B.4. EQUIPMENT LIST					
ASSET NUMBER	MANUFACTURER	MODEL	DESCRIPTION	LAST CAL	CAL DUE
00072	EMCO	2075	Mini-mast	n/a	n/a
00073	EMCO	2080	Turn Table	n/a	n/a
00071	EMCO	2090	Multi-Device Controller	n/a	n/a
00035	ETS	3115	Double Ridged Guide Horn	24Mar04	24Mar05
00015	Agilent	E4408B	Spectrum Analyzer	29Dec03	29Dec04
00048	Gore	65474	Microwave Cable	20May04	20May05

<b>Test Report S/N:</b>	052604-515/516KBC
<b>Test Date(s):</b>	28Jun04 - 29Jul04
<b>Test Type:</b>	FCC Part 15.247

### B.5. MEASUREMENT EQUIPMENT SETUP

<b>Measurement Equipment Connections</b>	The equipment was connected as shown in the setup drawing in B.6.
<b>Measurement Equipment Settings</b>	The following spectrum analyzer settings were use for these measurements: RBW – 100 kHz VBW – 300 kHz Span – 30 MHz

### B.6. SETUP DRAWING

Figure B-1 – Setup Drawing

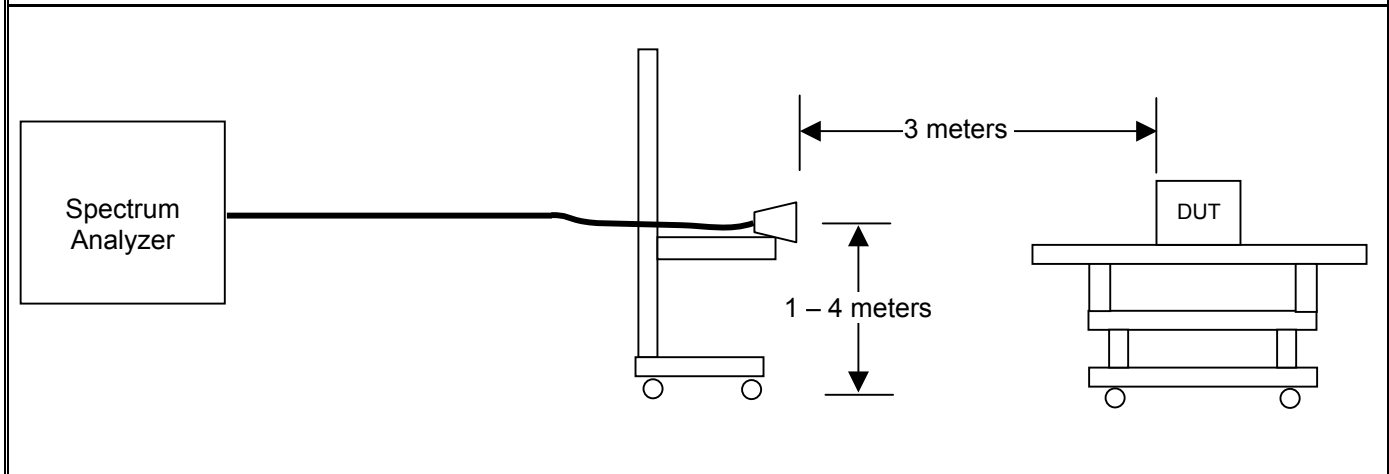

### B.7. DUT OPERATING DESCRIPTION

The worst-case data rate was determined from prescan investigations. Measurements were made at three channels throughout the band, Low Channel (2412 MHz), Mid Channel (2437 MHz), High Channel (2462 MHz) and for both Modes b and g.

### B.8. TEST RESULTS

Channel	Frequency	802.11b			802.11g		
		6 dB Bandwidth	Limit	Data Rate	6 dB Bandwidth	Limit	Data Rate
	MHz	kHz	kHz	Mbps	kHz	kHz	Mbps
Low	2412	9127	>500	1	16444	>500	6
Mid	2437	9553	>500	1	16379	>500	6
High	2462	9169	>500	1	16402	>500	6

<b>Test Report S/N:</b>	052604-515/516KBC
<b>Test Date(s):</b>	28Jun04 - 29Jul04
<b>Test Type:</b>	FCC Part 15.247

Plot B-1 - 6 dB Bandwidth Low Channel (802.11b)

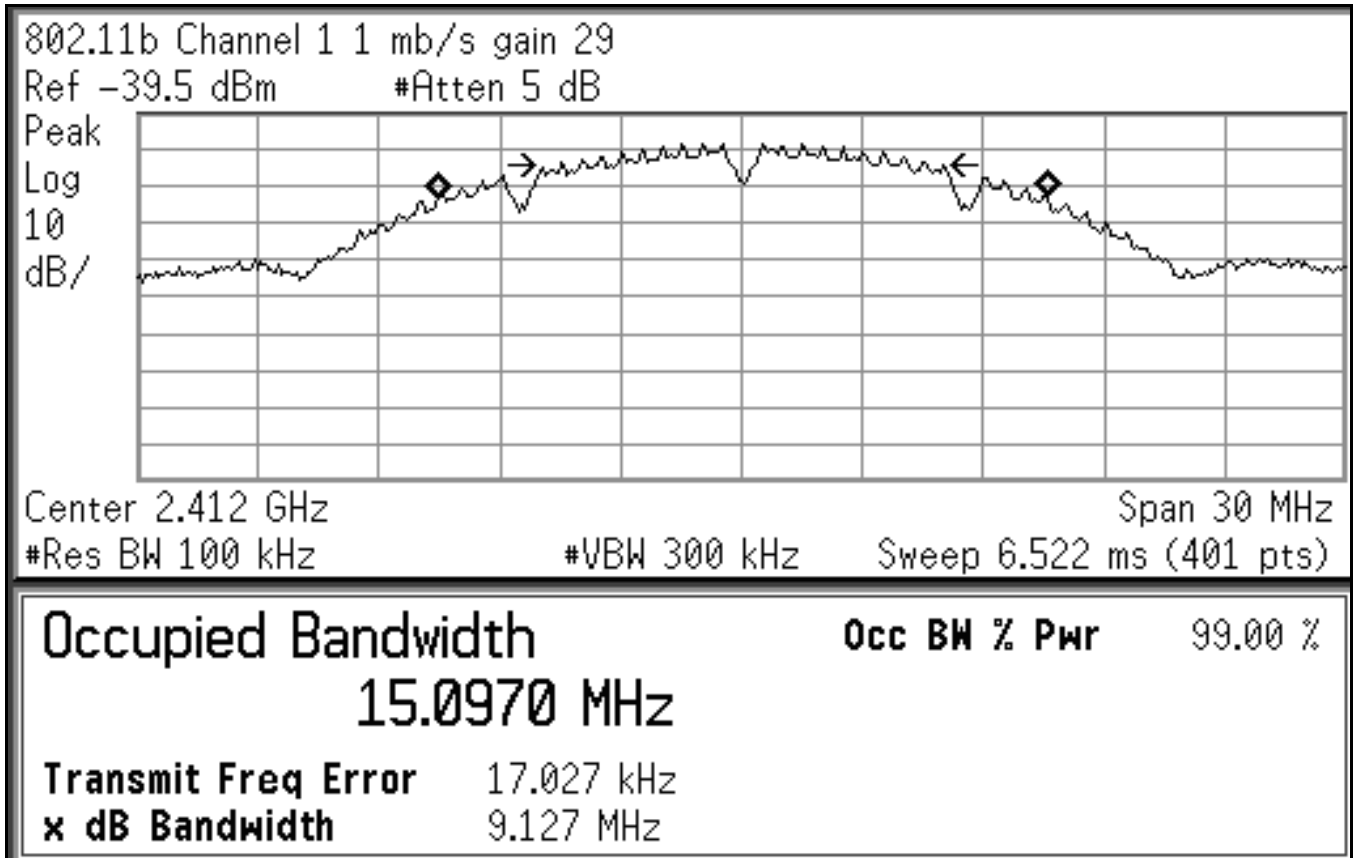

<b>Test Report S/N:</b>	052604-515/516KBC
<b>Test Date(s):</b>	28Jun04 - 29Jul04
<b>Test Type:</b>	FCC Part 15.247

Plot B-2 - 6 dB Bandwidth Mid Channel (802.11b)

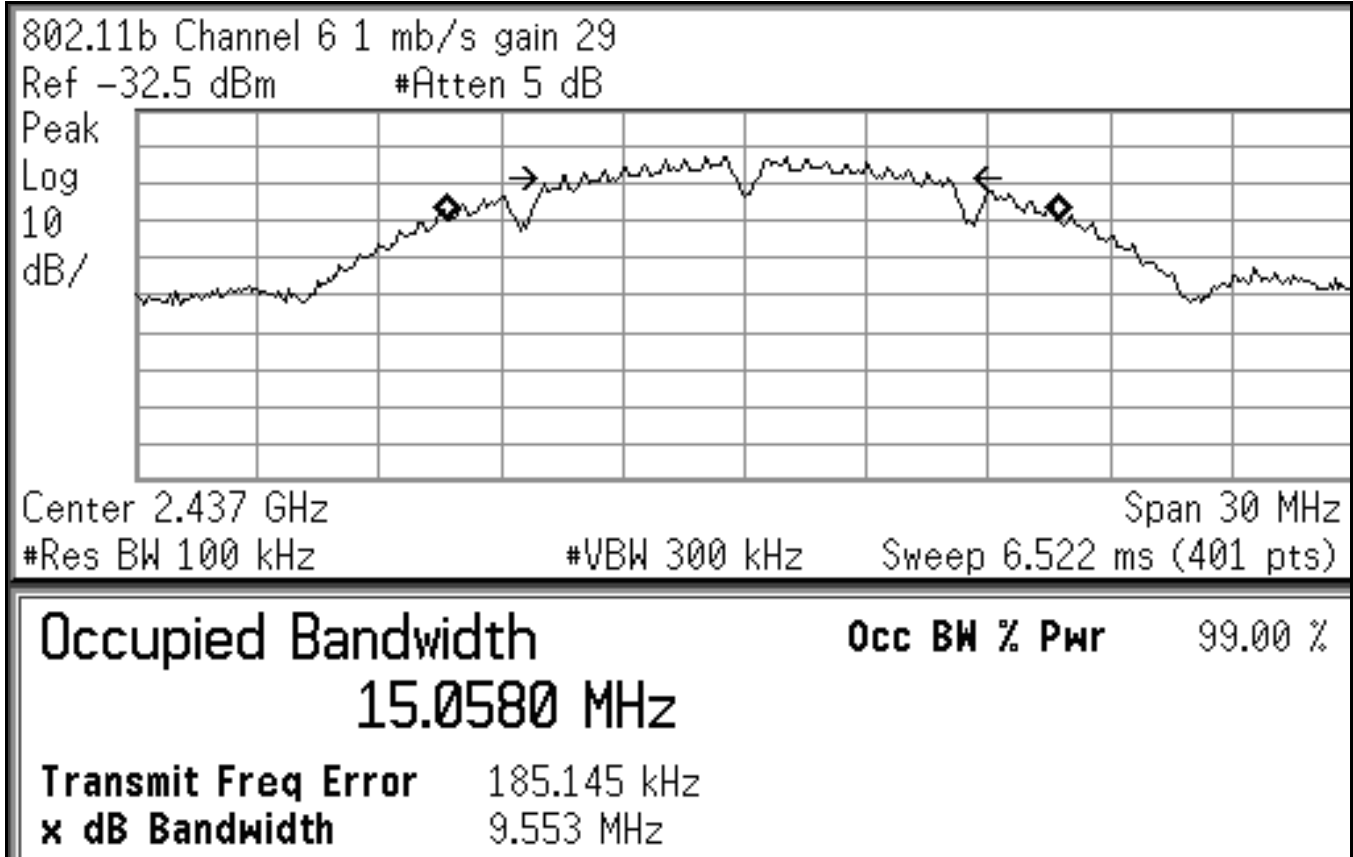

<b>Test Report S/N:</b>	052604-515/516KBC
<b>Test Date(s):</b>	28Jun04 - 29Jul04
<b>Test Type:</b>	FCC Part 15.247

Plot B-3 - 6 dB Bandwidth High Channel (802.11b)

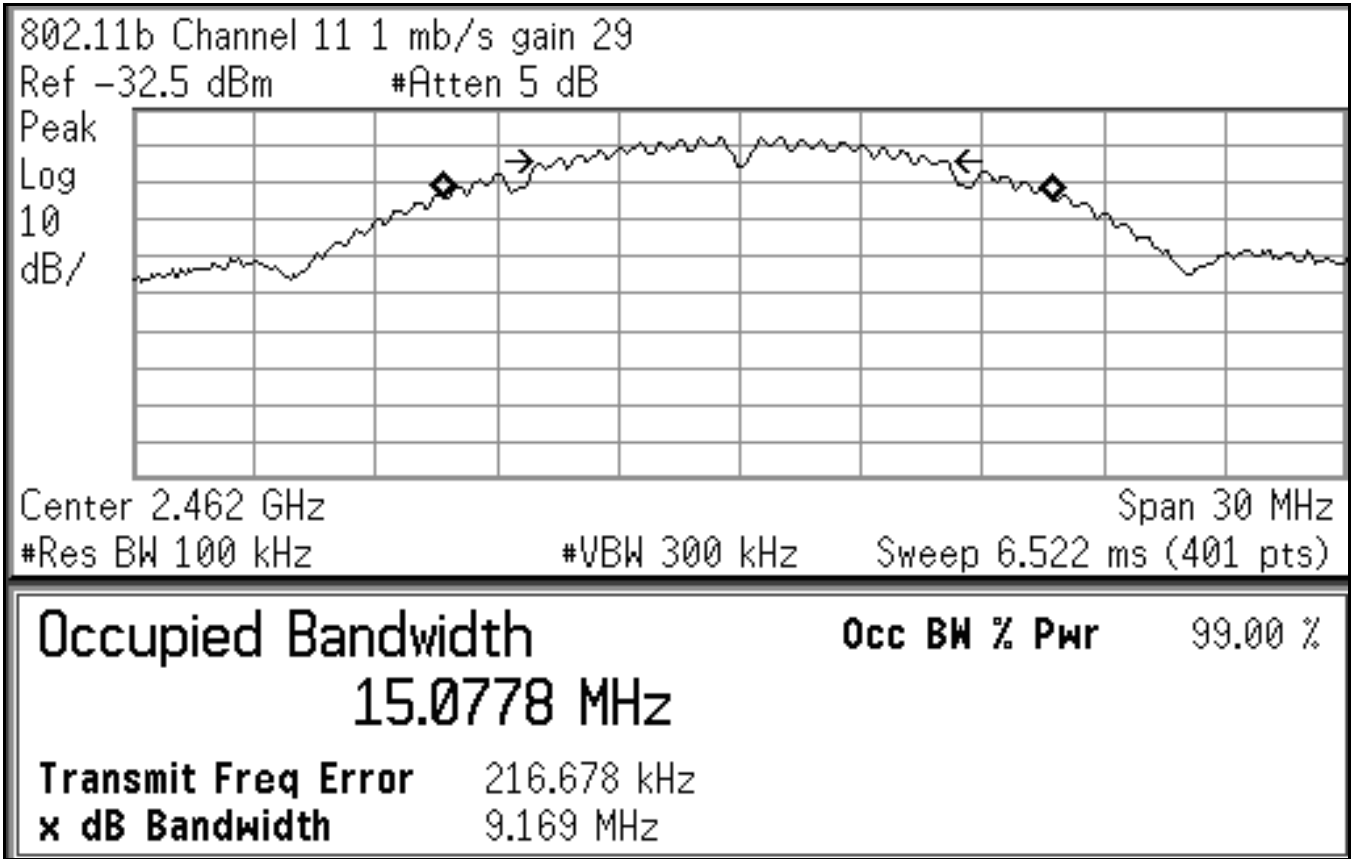

Test Report S/N:	052604-515/516KBC
Test Date(s):	28Jun04 - 29Jul04
Test Type:	FCC Part 15.247

Plot B-4 - 6 dB Bandwidth Low Channel (802.11g)

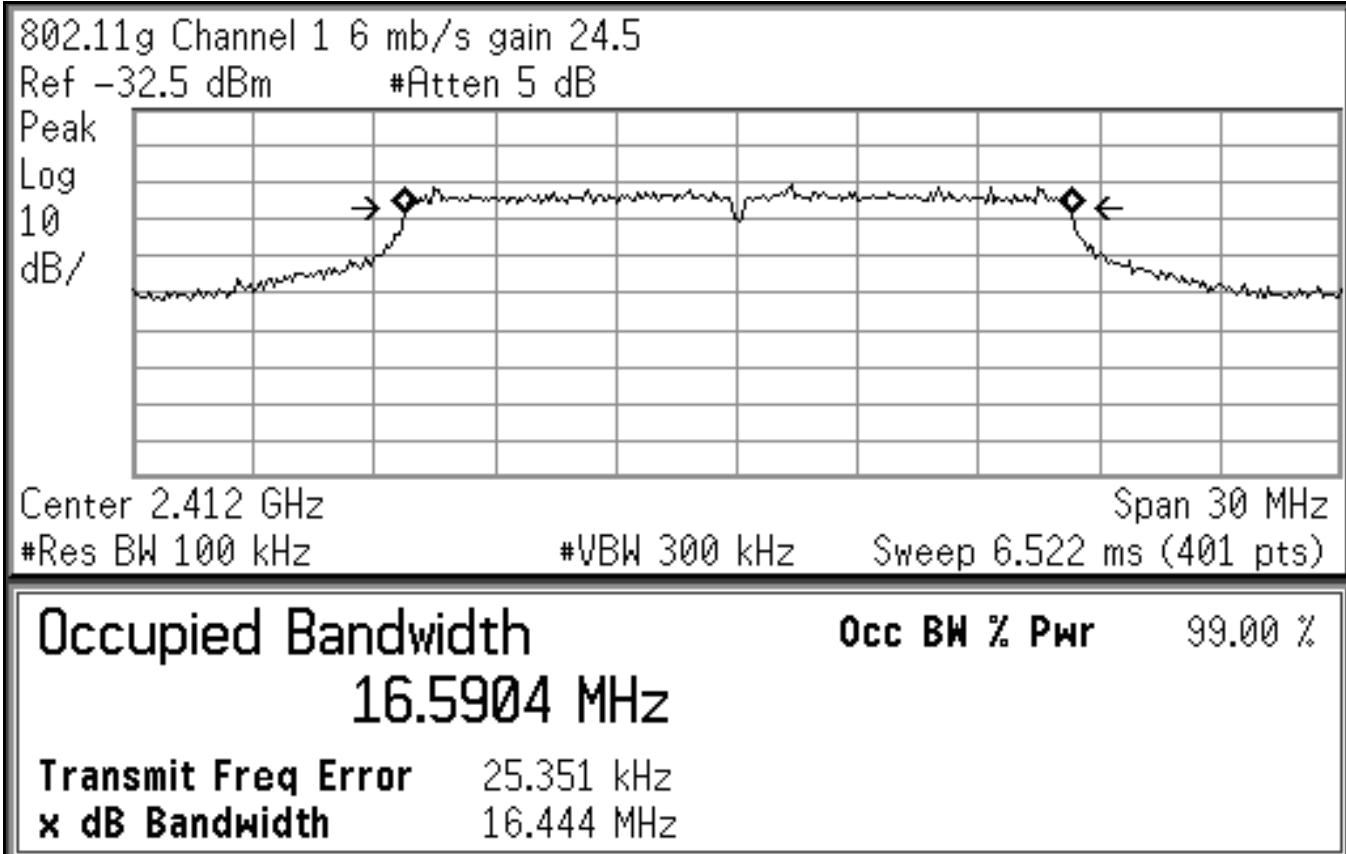



<b>Test Report S/N:</b>	052604-515/516KBC
<b>Test Date(s):</b>	28Jun04 - 29Jul04
<b>Test Type:</b>	FCC Part 15.247

Plot B-5 - 6 dB Bandwidth Mid Channel (802.11g)

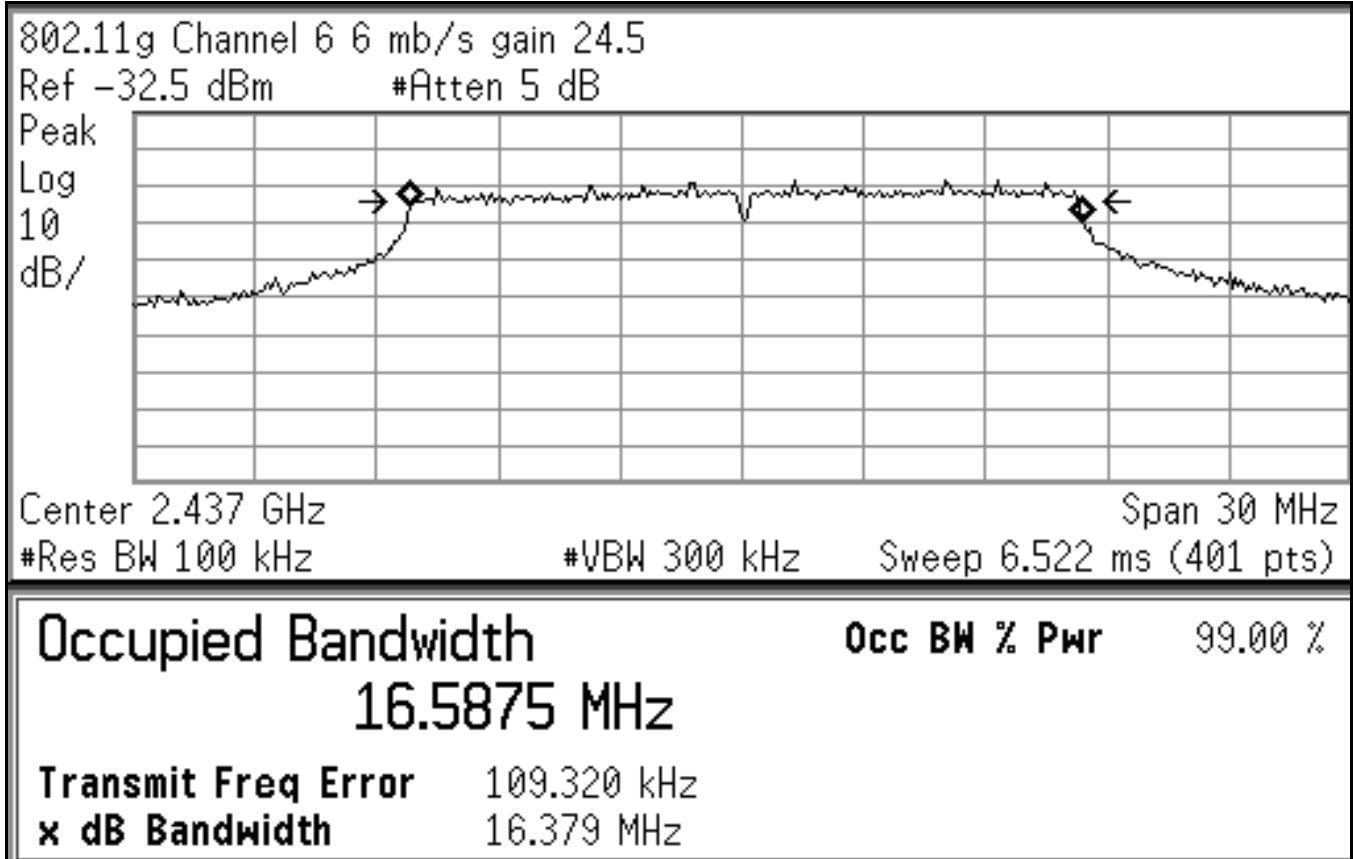

<b>Test Report S/N:</b>	052604-515/516KBC
<b>Test Date(s):</b>	28Jun04 - 29Jul04
<b>Test Type:</b>	FCC Part 15.247

Plot B-6 - 6 dB Bandwidth High Channel (802.11g)

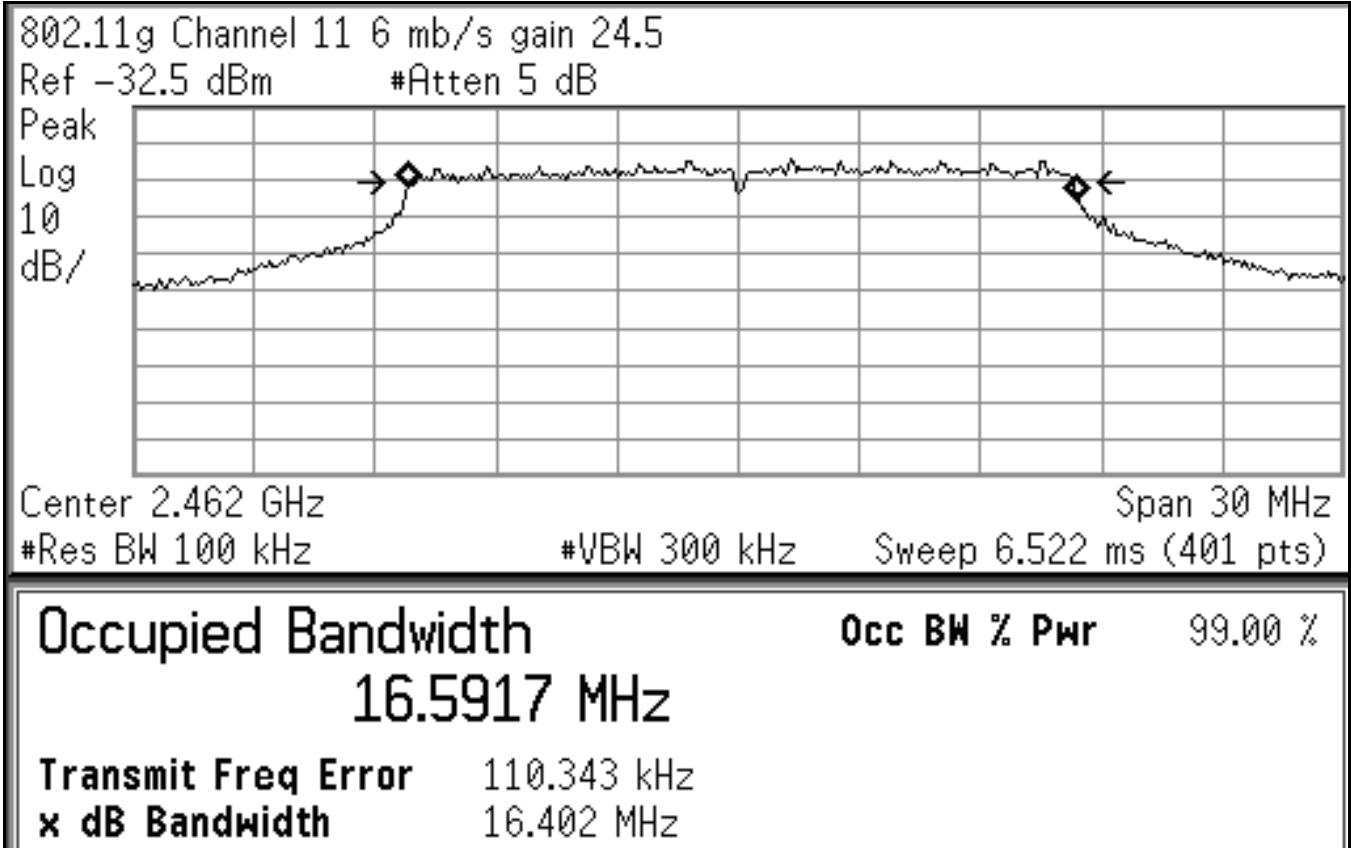

<b>Test Report S/N:</b>	052604-515/516KBC
<b>Test Date(s):</b>	28Jun04 - 29Jul04
<b>Test Type:</b>	FCC Part 15.247

**B.9. PASS/FAIL**

In reference to the results outlined in B.8 the DUT passes the requirements as stated in the reference standards as follows:  
 FCC 15.247 (2): The 6 dB bandwidth as measured meets the minimum 500 kHz bandwidth requirement.

**B.10. SIGN-OFF**

I attest to the accuracy of the data. All measurements reported herein were performed by me and are correct to the best of my knowledge and belief. I assume full responsibility for the completeness of these measurements.



\_\_\_\_\_  
 Duane M. Friesen, C.E.T.  
 EMC Manager  
 Celltech Labs Inc.

\_\_\_\_\_  
 29Jul04

Date

<b>Test Report S/N:</b>	052604-515/516KBC
<b>Test Date(s):</b>	28Jun04 - 29Jul04
<b>Test Type:</b>	FCC Part 15.247

### Appendix C - Peak Conducted Power Measurement

C.1. REFERENCES	
<b>Normative Reference Standard</b>	FCC CFR 47 §15.247(b) (3)
<b>Procedure Reference</b>	FCC 97-114

C.2. LIMITS	
C.2.1. FCC CFR	
<p>§15.247(b): The maximum peak output power of the intentional radiator shall not exceed the following:          §15.247(b) (3) For system using digital modulation in the 902 – 928 MHz, 2400 – 2483.5 MHz, and 5725 – 5850 MHz bands: 1 Watt.</p>	

C.3. ENVIRONMENTAL CONDITIONS	
<b>Temperature</b>	25.2 +/- 2 °C
<b>Humidity</b>	35 +/- 2 %
<b>Barometric Pressure</b>	96.34 kPa

C.4. EQUIPMENT LIST					
ASSET NUMBER	MANUFACTURER	MODEL	DESCRIPTION	LAST CAL	CAL DUE
00015	Agilent	E4408B	Spectrum Analyzer	29Dec03	29Dec04
00075	Alpha Wire-J	9223	2ft. RG223/U RF Cable	08Jul04*	24Jun05
00076	Pasternack	PE7014-30	30dB 2 Watt Attenuator	08Jul04*	24Jun05

\*Cable and attenuator verified with power meter prior to use

C.5. MEASUREMENT EQUIPMENT SETUP	
<b>Measurement Equipment Connections</b>	The equipment was connected as shown in the setup drawing in C.6.
<b>Measurement Equipment Settings</b>	<p>To evaluate the maximum peak power, the 26 dB bandwidth needs to be determined. This is performed with the spectrum analyzer using the following setting:            RBW – 300 kHz            VBW – 1MHz            Span – 50 MHz            Detector – Peak            Average – Power            Trace Average – 100</p> <p>Once the 26 dB bandwidth is determined, the power is measured within the band with the following spectrum analyzer settings:            RBW – 1 MHz            VBW – 3 MHz            Detector – Peak            Average – Power            Integrate BW – equal to specific –26 dB EBW</p>

<b>Test Report S/N:</b>	052604-515/516KBC
<b>Test Date(s):</b>	28Jun04 - 29Jul04
<b>Test Type:</b>	FCC Part 15.247

**C.6. SETUP DRAWING**

Figure C-1 – Setup Drawing

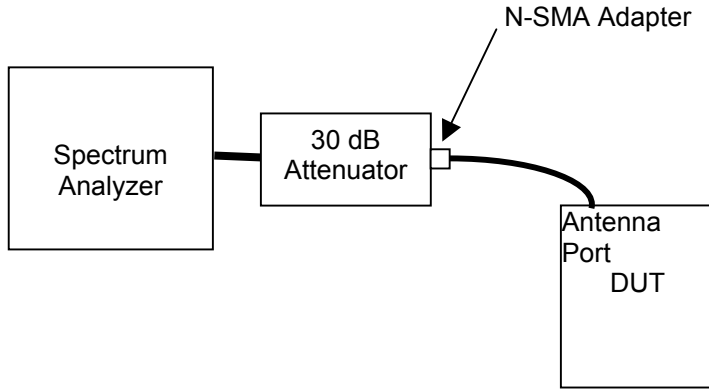

**C.7. DUT OPERATING DESCRIPTION**

The worst-case data rate was determined from prescan investigations. Measurements were made at three channels throughout the band, Low Channel (2412 MHz), Mid Channel (2437 MHz), High Channel (2462 MHz) and for both Modes b and g.

**C.8. TEST RESULTS**

Channel	Frequency	802.11b				802.11g			
		Peak Conducted Power		Limit	-26 dB EBW	Peak Conducted Power		Limit	-26 dB EBW
	MHz	dBm	Watts	Watts	MHz	dBm	Watts	Watts	MHz
Low	2412	16.28	.0424	1	19.53	15.14	.0327	1	23.55
Mid	2437	16.79	.0478	1	19.45	15.55	.0359	1	23.17
High	2462	17.48	.0560	1	19.43	16.15	.0412	1	23.05

<b>Test Report S/N:</b>	052604-515/516KBC
<b>Test Date(s):</b>	28Jun04 - 29Jul04
<b>Test Type:</b>	FCC Part 15.247

**C.9. PASS/FAIL**

In reference to the results outlined in C.8 the DUT passes the requirements as stated in the reference standards as follows:  
FCC 15.247 (b) (3): The peak power did not exceed 1 Watt.

**C.10. SIGN-OFF**

I attest to the accuracy of the data. All measurements reported herein were performed by me and are correct to the best of my knowledge and belief. I assume full responsibility for the completeness of these measurements.



Russell Pipe  
Senior Compliance Technologist  
Celltech Labs Inc.

29Jul04

Date

<b>Test Report S/N:</b>	052604-515/516KBC
<b>Test Date(s):</b>	28Jun04 - 29Jul04
<b>Test Type:</b>	FCC Part 15.247

### Appendix D - Maximum Permissible Exposure Calculation

D.1. REFERENCES	
<b>Normative Reference Standard</b>	FCC CFR 47§1.1310 IEEE Std C95.1-1992
<b>Procedure Reference</b>	FCC CFR 47§2.1091

D.2. LIMITS	
FCC CFR 47§1.1310 Table 1(b)	1.0 mW/cm <sup>2</sup>

D.3. ENVIRONMENTAL CONDITIONS	
<b>Temperature</b>	na
<b>Humidity</b>	na
<b>Barometric Pressure</b>	na

D.4. EQUIPMENT LIST					
ASSET NUMBER	MANUFACTURER	MODEL	DESCRIPTION	LAST CAL	CAL DUE
na					

D.5. MEASUREMENT EQUIPMENT SETUP	
<b>MEASUREMENT EQUIPMENT CONNECTIONS</b>	The results described herein were determined by the following calculation, so no measurement equipment was used.
<b>MEASUREMENT EQUIPMENT SETTINGS</b>	na

D.6. SETUP PHOTOS	
na	

D.7. SETUP DRAWINGS	
na	

D.8. DUT OPERATING DESCRIPTION	
na	





<b>Test Report S/N:</b>	052604-515/516KBC
<b>Test Date(s):</b>	28Jun04 - 29Jul04
<b>Test Type:</b>	FCC Part 15.247

**D.10. PASS/FAIL**

In reference to the results outlined in D.9 the DUT passes the requirements as stated in the reference standards as follows:  
 1) The DUT spacing must be kept at 20 cm to insure an exposure not more than 1 mW/cm<sup>2</sup>.

**D.11. SIGN-OFF**

I attest to the accuracy of the data. All measurements reported herein were performed by me and are correct to the best of my knowledge and belief. I assume full responsibility for the completeness of these measurements.



Russell Pipe  
 Senior Compliance Technologist  
 Celltech Labs Inc.

29Jul04

Date

<b>Test Report S/N:</b>	052604-515/516KBC
<b>Test Date(s):</b>	28Jun04 - 29Jul04
<b>Test Type:</b>	FCC Part 15.247

### Appendix E - Radiated Spurious Emissions Measurement

E.1. REFERENCES	
<b>Normative Reference Standard</b>	FCC CFR 47 §15.247(c)
<b>Procedure Reference</b>	ANSI C63.4; FCC 97-114

E.2. LIMITS	
E.2.1. FCC CFR 47	
<p>§15.247 (c): In any 100 kHz bandwidth outside the frequency band in which the spread spectrum or digitally modulated intentional radiator is operating, the radio frequency power that is produced by the intentional radiator shall be at least 20 dB below that in the 100 kHz bandwidth within the band that contains the highest level of desired power, based on either an RF conducted or a radiated measurement. Attenuation below the general limits specified in 15.209 (a) is not required.</p>	
<p>Note: Spurious emissions within the restricted bands are reported in Appendix F.</p>	

E.3. ENVIRONMENTAL CONDITIONS	
<b>Temperature</b>	27.4 +/- 2 °C
<b>Humidity</b>	33 +/- 2 %
<b>Barometric Pressure</b>	96.24 +/- 0.2 kPa

E.4. EQUIPMENT LIST					
ASSET NUMBER	MANUFACTURER	MODEL	DESCRIPTION	LAST CAL	CAL DUE
00072	EMCO	2075	Mini-mast	n/a	n/a
00073	EMCO	2080	Turn Table	n/a	n/a
00071	EMCO	2090	Multi-Device Controller	n/a	n/a
00050	Chase	CBL-6111A	Bilog Antenna	30Apr04	30Apr05
00035	ETS	3115	Double Ridged Guide Horn	24Mar04	24Mar05
00202	ETS	3160-09	Small Horn Antenna	27May04	27Jun05
00015	Agilent	E4408B	Spectrum Analyzer	29Dec03	29Dec04
00049	HP	8566B	Spectrum Analyzer RF Section	18May04	18May05
00049	HP	85650A	Quasi-peak Adapter	18May04	18May05
00047	HP	85685A	RF Preselector	18May04	18May05
00048	Gore	65474	Microwave Cable	20May04	20May05
00030	HP	83017A	LNA	20May04	20May05

<b>Test Report S/N:</b>	052604-515/516KBC
<b>Test Date(s):</b>	28Jun04 - 29Jul04
<b>Test Type:</b>	FCC Part 15.247

**E.5. MEASUREMENT EQUIPMENT SETUP**

<b>MEASUREMENT EQUIPMENT CONNECTIONS</b>	The measurement equipment was connected as shown in E.6. A number of antennas were used to cover the applicable frequency range test. The ranges in which each antenna was used are as follows:			
	Frequency Range	Antenna		
	30 MHz – 1 GHz	CBL-6111A Bilog		
	1 GHz – 18 GHz	ETS 3115 Horn		
	18 GHz– 26GHz	ETS 3160-09 Horn		
<b>MEASUREMENT EQUIPMENT SETTINGS</b>	The spectrum analyzer was set to the following settings:			
	Frequency Range	RBW	VBW	Detector
	MHz	kHz	kHz	
	30 – 1000	100	300	Peak*
	> 1000	1000*	1000	Peak*
*As a worse case measurement, the average limit was applied to measurements made with a peak detector using a RBW of 1 MHz (vs the specified 100 kHz), when possible.				

**E.6. SETUP DRAWING**

Figure E-1 – Setup Drawing

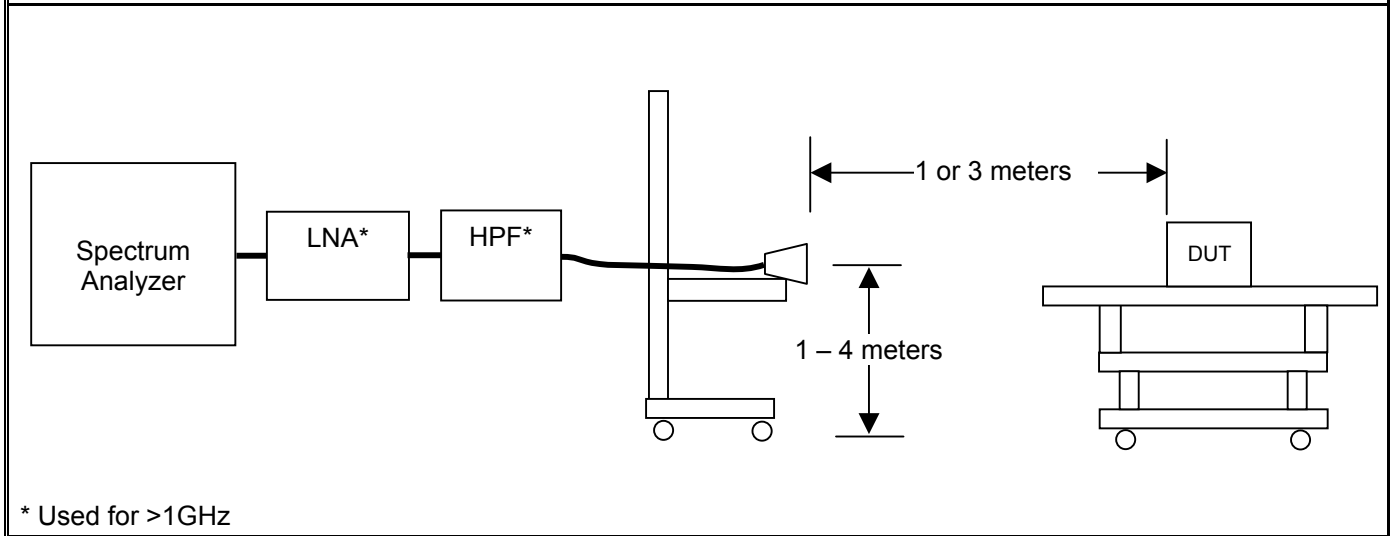

<b>Test Report S/N:</b>	052604-515/516KBC
<b>Test Date(s):</b>	28Jun04 - 29Jul04
<b>Test Type:</b>	FCC Part 15.247

**E.7. SETUP PHOTOGRAPHS**

Photograph E-1 - Horizontal Polarization (30MHz – 1 GHz)

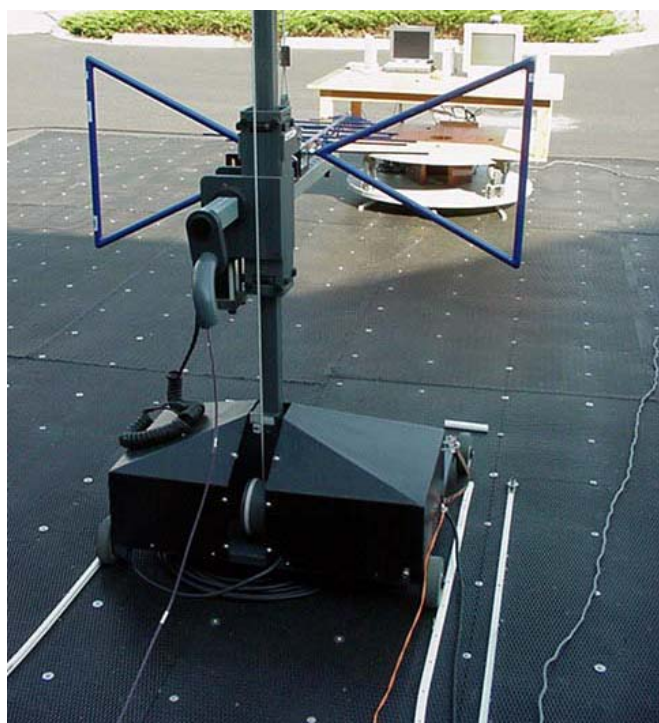

Photograph E-2 - Vertical Polarization (30MHz – 1 GHz)



Photograph E-3 - Front of Radiated Emission Configuration



Photograph E-4 - Back of Radiated Emission Configuration

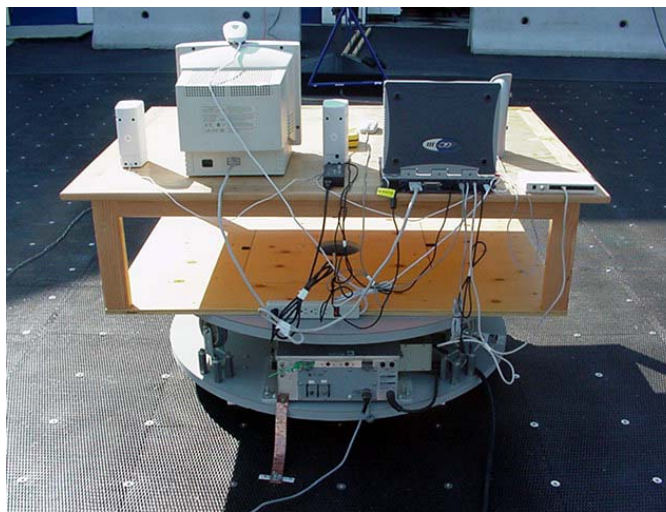

<b>Itronix Corporation</b>	<b>FCC ID:</b>	<b>KBCIX260PRO2200</b>	<b>Model:</b>	<b>IX260+ with Intel Pro 2200BG WLAN</b>
2004 Celltech Labs Inc	<b>Rugged Laptop PC with internal WLAN Mini-PCI Card (802.11b/g)</b>			36 of 84
This document is not to be reproduced in whole or in part without the written permission of Celltech Labs Inc.				

<b>Test Report S/N:</b>	052604-515/516KBC
<b>Test Date(s):</b>	28Jun04 - 29Jul04
<b>Test Type:</b>	FCC Part 15.247

### E.8. DUT OPERATING DESCRIPTION

The worst-case data rate was determined from prescan investigations. Measurements were made at three channels throughout the band, Low Channel (2412 MHz), Mid Channel (2437 MHz), High Channel (2462 MHz) and for both Modes b and g for the band-edge measurements and for Mode b for the remaining measurements. The configuration used was Mode b, 1 mbps with a gain setting of 29 and Mode g, 6 mbps with a gain setting of 24.5.

### E.9. TEST RESULTS

#### E.9.1. Mode b - Fundamental Field Strengths @ Specified Distance – Horizontal Polarization

Channel	Polarity	Measurement Distance	Antenna	Frequency	SA Level	Noise Floor	Antenna Factor	Cable Factor	Other Factors	Total CF	Field Strength	Detector	Limit Distance	Limit Distance Correction	*Calculated Limit
1	H	3	Horn SN6276	2412.00	70.11		28.11	3.49	0.00	31.59	101.70	PK	3	0.00	81.70
6	H	3	Horn SN6276	2437.00	70.00		28.16	3.51	0.00	31.67	101.67	PK	3	0.00	81.67
11	H	3	Horn SN6276	2462.00	70.50		28.22	3.52	0.00	31.73	102.23	PK	3	0.00	82.23

#### E.9.2. Mode b - Fundamental Field Strengths @ Specified Distance – Vertical Polarization

1	V	3	Horn SN6276	2412.00	64.50		28.11	3.49	0.00	31.59	96.09	PK	3	0.00	76.09
6	V	3	Horn SN6276	2437.00	63.70		28.16	3.51	0.00	31.67	95.37	PK	3	0.00	75.37
11	V	3	Horn SN6276	2462.00	64.91		28.22	3.52	0.00	31.73	96.64	PK	3	0.00	76.64

**Formulae:**

Total CF = Antenna Factor + Cable Factor + Other Factor (Amplifier Gain, filter loss, etc)

Field Strength = SA Reading + Total CF

Limit Distance Correction =  $40 \cdot \log(d1/d2)$  for  $F < 30$  MHz,  $20 \cdot \log(d1/d2)$  for  $F > 30$  MHz :  
where d1 is the measurement distance

Limit = Specified Limit + Limit Distance Correction

Margin = Limit - Field Strength

Calculated Limit (-20 dBc) = Field Strength -20

\*Calculated Limit used for spurious emission evaluation

<b>Test Report S/N:</b>	052604-515/516KBC
<b>Test Date(s):</b>	28Jun04 - 29Jul04
<b>Test Type:</b>	FCC Part 15.247

E.9.3. Mode b - Band-edge Emission Field Strengths @ Specified Distance – Horizontal Polarization (not near restricted band)																	
Channel	Polarity	Measurement Distance	Antenna	Frequency	SA Level	Noise Floor	Antenna Factor	Cable Factor	Other Factors	Total CF	Field Strength	Detector	Limit Distance	Limit Distance Correction	-20 dBc Limit	Margin	Pass/Fail
1	H	3	Horn SN6276	2400.00	30.60		28.08	3.48	0.00	31.56	62.16	PK	3.00	0.00	81.70	19.54	PASS
1	H	3	Horn SN6276	2400.00	20.30		28.08	3.48	0.00	31.56	51.86	AV	3.00	0.00	81.70	29.84	PASS

E.9.4. Mode b - Band-edge Emission Field Strengths @ Specified Distance - Vertical Polarization (not near restricted band)																	
1	V	3	Horn SN6276	2400.00	27.60		28.08	3.48	0.00	31.56	59.16	PK	3.00	0.00	76.09	16.93	PASS
1	V	3	Horn SN6276	2400.00	18.70		28.08	3.48	0.00	31.56	50.26	AV	3.00	0.00	76.09	25.83	PASS

Formulae:  
 Total CF = Antenna Factor + Cable Factor + Other Factor (Amplifier Gain, filter loss, etc)  
 Field Strength = SA Reading + Total CF  
 Limit Distance Correction = 40\*log(d1/d2) for F<30 MHz, 20\*log(d1/d2) for F> 30 MHz:  
 where d1 is the measurement distance, d2 is the published limit distance  
 Limit = Specified Limit + Limit Distance Correction  
 Margin = Limit - Field Strength

E.9.5. Mode g - Band-edge Emission Field Strengths @ Specified Distance – Horizontal Polarization (not near restricted band)																	
Channel	Polarity	Measurement Distance	Antenna	Frequency	SA Level*	Noise Floor	Antenna Factor	Cable Factor	Other Factors	Total CF	Field Strength	Detector	Limit Distance	Limit Distance Correction	-20 dBc Limit	Margin	Pass/Fail
1	H	3	Horn SN6276	2400.00	89.24		28.08	7.66	-37.38	-1.64	87.6	PK	3.00	0.00	88.4	0.8	PASS
1	H	3	Horn SN6276	2400.00	66.04		28.08	7.66	-37.38	-1.64	64.4	AV	3.00	0.00	88.4	24.0	PASS

E.9.6. Mode b - Band-edge Emission Field Strengths @ Specified Distance - Vertical Polarization (not near restricted band)																	
1	V	3	Horn SN6276	2400.00	82.84		28.08	7.66	-37.38	-1.64	81.20	PK	3.00	0.00	82.6	1.4	PASS
1	V	3	Horn SN6276	2400.00	63.54		28.08	7.66	-37.38	-1.64	61.9	AV	3.00	0.00	82.6	20.7	PASS

Formulae:  
 Total CF = Antenna Factor + Cable Factor + Other Factor (Amplifier Gain, filter loss, etc)  
 Field Strength = SA Reading + Total CF  
 Limit Distance Correction = 40\*log(d1/d2) for F<30 MHz, 20\*log(d1/d2) for F> 30 MHz:  
 where d1 is the measurement distance, d2 is the published limit distance  
 Limit = Specified Limit + Limit Distance Correction  
 Margin = Limit - Field Strength

\*Measurements made with a worse case gain setting of 29

<b>Test Report S/N:</b>	052604-515/516KBC
<b>Test Date(s):</b>	28Jun04 - 29Jul04
<b>Test Type:</b>	FCC Part 15.247

**E.9.7. Channel 1 Harmonic Emission Field Strengths @ Specified Distance – Horizontal Polarization**

Channel	Polarity	Measurement Distance	Antenna	Frequency	SA Level	Noise Floor	Antenna Factor	Cable Factor	Other Factors	Total CF	Field Strength	Detector	Limit Distance	Limit Distance Correction	-20 dBc Limit	Margin	Pass/Fail
							dB/m	dB	dB	dB/m	dBuV/m		m	dB	dBuV/m	Δ dB	
1	H	3	Horn SN6276	1000.00	53.90		24.30	2.21	-10.66	15.85	69.75	PK	3.00	0.00	81.70	11.95	PASS
1	H	3	Horn SN6276	2500.00	42.60		28.30	3.51	-36.42	-4.61	37.99	PK	3.00	0.00	81.70	43.71	PASS
1	H	3	Horn SN6276	17660.00	38.00		44.88	10.46	-36.36	18.98	56.98	PK	3.00	0.00	81.70	24.72	PASS
1	H	1	3160-09	19296.00	52.98		40.26	11.01	-35.81	15.45	68.43	PK	3.00	9.54	91.24	22.81	PASS
1	H	1	3160-09	19296.00	34.05	x	40.26	11.01	-35.81	15.45	49.50	AV	3.00	9.54	91.24	41.74	PASS
1	H	1	3160-09	21708.00	53.65	x	40.30	11.91	-35.73	16.48	70.13	PK	3.00	9.54	91.24	21.11	PASS
1	H	1	3160-09	21708.00	35.74	x	40.30	11.91	-35.73	16.48	52.22	AV	3.00	9.54	91.24	39.02	PASS
1	H	1	3160-09	24120.00	56.09		40.40	12.81	-35.73	17.48	73.57	PK	3.00	9.54	91.24	17.67	PASS
1	H	1	3160-09	24120.00	37.57		40.40	12.81	-35.73	17.48	55.05	AV	3.00	9.54	91.24	36.19	PASS
1	H	1	3160-09	24490.00	57.15	x	40.40	12.95	-35.73	17.62	74.77	PK	3.00	9.54	91.24	16.47	PASS

**E.9.8. Channel 1 Harmonic Emission Field Strengths @ Specified Distance - Vertical Polarization**

1	V	3	Horn SN6276	4810.00	47.00	x	32.88	4.96	-35.30	2.54	49.54	PK	3.00	0.00	76.09	26.55	PASS
1	V	3	Horn SN6276	9610.00	36.60		37.59	7.37	-35.71	9.25	45.85	AV	3.00	0.00	76.09	30.24	PASS
1	V	1	Horn SN6276	17770.00	37.60		45.70	10.30	-36.35	19.65	57.25	PK	3.00	9.54	85.63	28.39	PASS
1	V	1	3160-09	18820.00	53.92	x	40.20	11.05	-35.87	15.38	69.30	PK	3.00	9.54	85.63	16.33	PASS
1	V	1	3160-09	18820.00	33.66	x	40.20	11.05	-35.87	15.38	49.04	AV	3.00	9.54	85.63	36.59	PASS
1	V	1	3160-09	19296.00	52.65		40.26	11.01	-35.81	15.45	68.10	PK	3.00	9.54	85.63	17.53	PASS
1	V	1	3160-09	19296.00	33.76		40.26	11.01	-35.81	15.45	49.21	AV	3.00	9.54	85.63	36.42	PASS
1	V	1	3160-09	21708.00	53.27		40.30	11.91	-35.73	16.48	69.75	PK	3.00	9.54	85.63	15.88	PASS
1	V	1	3160-09	21708.00	36.04		40.30	11.91	-35.73	16.48	52.52	AV	3.00	9.54	85.63	33.11	PASS
1	V	1	3160-09	24120.00	56.03		40.40	12.81	-35.73	17.48	73.51	PK	3.00	9.54	85.63	12.12	PASS
1	V	1	3160-09	24120.00	37.21		40.40	12.81	-35.73	17.48	54.69	AV	3.00	9.54	85.63	30.94	PASS
1	V	1	3160-09	24550.00	56.31	x	40.40	12.97	-35.73	17.64	73.95	PK	3.00	9.54	85.63	11.68	PASS
1	V	1	3160-09	24550.00	38.30	x	40.40	12.97	-35.73	17.64	55.94	AV	3.00	9.54	85.63	29.69	PASS

**Formulae:**

Total CF = Antenna Factor + Cable Factor + Other Factor (Amplifier Gain, filter loss, etc)

Field Strength = SA Reading + Total CF

Limit Distance Correction = 40\*log(d1/d2) for F<30 MHz, 20\*log(d1/d2) for F> 30 MHz:

where d1 is the measurement distance, d2 is the published limit distance

Limit = Specified Limit + Limit Distance Correction

Margin = Limit - Field Strength

\*No harmonic emission where measured above the field strengths noted

<b>Test Report S/N:</b>	052604-515/516KBC
<b>Test Date(s):</b>	28Jun04 - 29Jul04
<b>Test Type:</b>	FCC Part 15.247

E.9.9. Channel 6 Harmonic Emission Field Strengths @ Specified Distance – Horizontal Polarization

Channel	Polarity	Measurement Distance	Antenna	Frequency	SA Level	Noise Floor	Antenna Factor	Cable Factor	Other Factors	Total CF	Field Strength	Detector	Limit Distance	Limit Distance Correction	-20 dBc Limit	Margin	Pass/Fail
							dB/m	dB	dB	dB/m	dBuV/m		m	dB	dBuV/m	Δ dB	
6	H	3	Horn SN6276	5260.00	45.20	x	33.72	5.23	-35.47	3.47	48.67	PK	3.00	0.00	81.67	33.00	PASS
6	H	3	Horn SN6276	8360.00	42.30		37.06	6.79	-35.62	8.24	50.54	AV	3.00	0.00	81.67	31.13	PASS
6	H	3	Horn SN6276	17090.00	39.20		41.24	10.38	-36.09	15.54	54.74	PK	3.00	0.00	81.67	26.93	PASS
6	H	1	3160-09	19496.00	52.56		40.30	11.28	-35.79	15.79	68.35	PK	3.00	9.54	91.21	22.86	PASS
6	H	1	3160-09	19496.00	33.91		40.30	11.28	-35.79	15.79	49.70	AV	3.00	9.54	91.21	41.51	PASS
6	H	1	3160-09	21240.00	54.98	x	40.30	11.73	-35.73	16.31	71.29	PK	3.00	9.54	91.21	19.93	PASS
6	H	1	3160-09	21240.00	35.72	x	40.30	11.73	-35.73	16.31	52.03	AV	3.00	9.54	91.21	39.19	PASS
6	H	1	3160-09	21933.00	54.66		40.30	11.99	-35.73	16.57	71.23	PK	3.00	9.54	91.21	19.99	PASS
6	H	1	3160-09	21933.00	36.27		40.30	11.99	-35.73	16.57	52.84	AV	3.00	9.54	91.21	38.38	PASS
6	H	1	3160-09	24370.00	57.10		40.40	12.90	-35.73	17.58	74.68	PK	3.00	9.54	91.21	16.54	PASS
6	H	1	3160-09	24370.00	37.88		40.40	12.90	-35.73	17.58	55.46	AV	3.00	9.54	91.21	35.76	PASS
6	H	1	3160-09	24420.00	56.93	x	40.40	12.92	-35.73	17.60	74.53	PK	3.00	9.54	91.21	16.69	PASS
6	H	1	3160-09	24420.00	37.73	x	40.40	12.92	-35.73	17.60	55.33	AV	3.00	9.54	91.21	35.89	PASS

Formulae:

Total CF = Antenna Factor + Cable Factor + Other Factor (Amplifier Gain, filter loss, etc)

Field Strength = SA Reading + Total CF

Limit Distance Correction = 40\*log(d1/d2) for F<30 MHz, 20\*log(d1/d2) for F> 30 MHz:

where d1 is the measurement distance, d2 is the published limit distance

Limit = Specified Limit + Limit Distance Correction

Margin = Limit - Field Strength

\*No harmonic emission where measured above the field strengths noted



<b>Test Report S/N:</b>	052604-515/516KBC
<b>Test Date(s):</b>	28Jun04 - 29Jul04
<b>Test Type:</b>	FCC Part 15.247

E.9.10. Channel 6 Harmonic Emission Field Strengths @ Specified Distance - Vertical Polarization

Channel	Polarity	Measurement Distance	Antenna	Frequency	SA Level	Noise Floor	Antenna Factor	Cable Factor	Other Factors	Total CF	Field Strength	Detector	Limit Distance	Limit Distance Correction	-20 dBc Limit	Margin	Pass/Fail
													m	dB	dBuV/m	Δ dB	
6	V	3	Horn SN6276	5770.00	40.10	x	34.21	5.45	-35.50	4.16	44.26	PK	3.00	0.00	75.37	31.11	PASS
6	V	3	Horn SN6276	9720.00	36.80		37.68	7.34	-35.71	9.31	46.11	PK	3.00	0.00	75.37	29.26	PASS
6	V	1	Horn SN6276	16480.00	38.30		38.45	10.25	-36.46	12.24	50.54	PK	3.00	9.54	84.91	34.37	PASS
6	V	1	3160-09	19190.00	54.26	x	40.24	10.91	-35.83	15.32	69.58	PK	3.00	9.54	84.91	15.33	PASS
6	V	1	3160-09	19190.00	33.78	x	40.24	10.91	-35.83	15.32	49.10	AV	3.00	9.54	84.91	35.81	PASS
6	V	1	3160-09	19496.00	52.89		40.30	11.28	-35.79	15.79	68.68	PK	3.00	9.54	84.91	16.23	PASS
6	V	1	3160-09	19496.00	33.88		40.30	11.28	-35.79	15.79	49.67	AV	3.00	9.54	84.91	35.24	PASS
6	V	1	3160-09	21933.00	53.99		40.30	11.99	-35.73	16.57	70.56	PK	3.00	9.54	84.91	14.36	PASS
6	V	1	3160-09	21933.00	36.23		40.30	11.99	-35.73	16.57	52.80	AV	3.00	9.54	84.91	32.12	PASS
6	V	1	3160-09	24370.00	55.56		40.40	12.90	-35.73	17.58	73.14	PK	3.00	9.54	84.91	11.78	PASS
6	V	1	3160-09	24370.00	37.88		40.40	12.90	-35.73	17.58	55.46	AV	3.00	9.54	84.91	29.46	PASS
6	V	1	3160-09	24400.00	56.66	x	40.40	12.91	-35.73	17.59	74.25	PK	3.00	9.54	84.91	10.66	PASS
6	V	1	3160-09	24400.00	37.87	x	40.40	12.91	-35.73	17.59	55.46	AV	3.00	9.54	84.91	29.45	PASS

Formulae:

Total CF = Antenna Factor + Cable Factor + Other Factor (Amplifier Gain, filter loss, etc)

Field Strength = SA Reading + Total CF

Limit Distance Correction =  $40 \cdot \log(d1/d2)$  for  $F < 30$  MHz,  $20 \cdot \log(d1/d2)$  for  $F > 30$  MHz:

where d1 is the measurement distance, d2 is the published limit distance

Limit = Specified Limit + Limit Distance Correction

Margin = Limit - Field Strength

\*No harmonic emission where measured above the field strengths noted

<b>Test Report S/N:</b>	052604-515/516KBC
<b>Test Date(s):</b>	28Jun04 - 29Jul04
<b>Test Type:</b>	FCC Part 15.247

E.9.11. Channel 11 Harmonic Emission Field Strengths @ Specified Distance – Horizontal Polarization

Channel	Polarity	Measurement Distance	Antenna	Frequency	SA Level	Noise Floor	Antenna Factor	Cable Factor	Other Factors	Total CF	Field Strength	Detector	Limit Distance	Limit Distance Correction	-20 dBc Limit	Margin	Pass/Fail
							dB/m	dB	dB	dB/m	dBuV/m		m	dB	dBuV/m	Δ dB	
11	H	3	Horn SN6276	5260.00	45.80	x	33.72	5.23	-35.47	3.47	49.27	PK	3.00	0.00	82.23	32.96	PASS
11	H	3	Horn SN6276	8360.00	42.10		37.06	6.79	-35.62	8.24	50.34	PK	3.00	0.00	82.23	31.89	PASS
11	H	1	Horn SN6276	15920.00	38.90		37.38	9.83	-36.23	10.98	49.88	PK	3.00	9.54	91.77	41.89	PASS
11	H	1	3160-09	18810.00	53.72	x	40.20	11.15	-35.87	15.48	69.20	PK	3.00	9.54	91.77	22.58	PASS
11	H	1	3160-09	18810.00	33.94	x	40.20	11.15	-35.87	15.48	49.42	AV	3.00	9.54	91.77	42.36	PASS
11	H	1	3160-09	19696.00	53.67		40.30	11.42	-35.76	15.95	69.62	PK	3.00	9.54	91.77	22.15	PASS
11	H	1	3160-09	19696.00	33.44		40.30	11.42	-35.76	15.95	49.39	AV	3.00	9.54	91.77	42.38	PASS
11	H	1	3160-09	22158.00	53.69		40.33	12.08	-35.73	16.68	70.37	PK	3.00	9.54	91.77	21.40	PASS
11	H	1	3160-09	22158.00	35.90		40.33	12.08	-35.73	16.68	52.58	AV	3.00	9.54	91.77	39.19	PASS
11	H	1	3160-09	24620.00	55.75		40.40	13.00	-35.73	17.67	73.42	PK	3.00	9.54	91.77	18.35	PASS
11	H	1	3160-09	24620.00	37.57		40.40	13.00	-35.73	17.67	55.24	AV	3.00	9.54	91.77	36.53	PASS
11	H	1	3160-09	24460.00	56.88	x	40.40	12.94	-35.73	17.61	74.49	PK	3.00	9.54	91.77	17.28	PASS
11	H	1	3160-09	24460.00	37.32	x	40.40	12.94	-35.73	17.61	54.93	AV	3.00	9.54	91.77	36.84	PASS

Formulae:

Total CF = Antenna Factor + Cable Factor + Other Factor (Amplifier Gain, filter loss, etc)

Field Strength = SA Reading + Total CF

Limit Distance Correction =  $40 \cdot \log(d1/d2)$  for  $F < 30$  MHz,  $20 \cdot \log(d1/d2)$  for  $F > 30$  MHz:

where d1 is the measurement distance, d2 is the published limit distance

Limit = Specified Limit + Limit Distance Correction

Margin = Limit - Field Strength

\*No harmonic emission where measured above the field strengths noted

<b>Test Report S/N:</b>	052604-515/516KBC
<b>Test Date(s):</b>	28Jun04 - 29Jul04
<b>Test Type:</b>	FCC Part 15.247

E.9.12. Channel 11 Harmonic Emission Field Strengths @ Specified Distance - Vertical Polarization

Channel	Polarity	Measurement Distance	Antenna	Frequency	SA Level	Noise Floor	Antenna Factor	Cable Factor	Other Factors	Total CF	Field Strength	Detector	Limit Distance	Limit Distance Correction	-20 dBc Limit	Margin	Pass/Fail
							dB/m	dB	dB	dB/m	dBuV/m		m	dB	dBuV/m	Δ dB	
11	V	3	Horn SN6276	5770.00	42.50	x	34.21	5.45	-35.50	4.16	46.66	PK	3.00	0.00	76.64	29.98	PASS
11	V	1	Horn SN6276	16680.00	39.00		39.29	10.24	-36.14	13.40	52.40	PK	3.00	9.54	86.18	33.79	PASS
11	V	1	3160-09	19696.00	53.07		40.30	11.42	-35.76	15.95	69.02	PK	3.00	9.54	86.18	17.16	PASS
11	V	1	3160-09	19696.00	33.28		40.30	11.42	-35.76	15.95	49.23	AV	3.00	9.54	86.18	36.95	PASS
11	V	1	3160-09	20660.00	55.02	x	40.30	11.74	-35.73	16.31	71.33	PK	3.00	9.54	86.18	14.85	PASS
11	V	1	3160-09	20660.00	35.18	x	40.30	11.74	-35.73	16.31	51.49	AV	3.00	9.54	86.18	34.69	PASS
11	V	1	3160-09	22158.00	54.12		40.33	12.08	-35.73	16.68	70.80	PK	3.00	9.54	86.18	15.38	PASS
11	V	1	3160-09	22158.00	35.80		40.33	12.08	-35.73	16.68	52.48	AV	3.00	9.54	86.18	33.70	PASS
11	V	1	3160-09	23950.00	57.28	x	40.40	12.75	-35.73	17.42	74.70	PK	3.00	9.54	86.18	11.48	PASS
11	V	1	3160-09	23950.00	36.43	x	40.40	12.75	-35.73	17.42	53.85	AV	3.00	9.54	86.18	32.33	PASS
11	V	1	3160-09	24620.00	55.73		40.40	13.00	-35.73	17.67	73.40	PK	3.00	9.54	86.18	12.78	PASS
11	V	1	3160-09	24620.00	37.92		40.40	13.00	-35.73	17.67	55.59	AV	3.00	9.54	86.18	30.59	PASS

Formulae:

Total CF = Antenna Factor + Cable Factor + Other Factor (Amplifier Gain, filter loss, etc)

Field Strength = SA Reading + Total CF

Limit Distance Correction =  $40 \cdot \log(d1/d2)$  for  $F < 30$  MHz,  $20 \cdot \log(d1/d2)$  for  $F > 30$  MHz:

where d1 is the measurement distance, d2 is the published limit distance

Limit = Specified Limit + Limit Distance Correction

Margin = Limit - Field Strength

\*No harmonic emission where measured above the field strengths noted

<b>Test Report S/N:</b>	052604-515/516KBC
<b>Test Date(s):</b>	28Jun04 - 29Jul04
<b>Test Type:</b>	FCC Part 15.247

E.9.13. Channel 1 Out-of-Band Spurious Emission Field Strengths @ Specified Distance – Horizontal Polarization

Channel	Polarity	Measurement Distance	Antenna	Frequency	SA Level	Noise Floor	Antenna Factor	Cable Factor	Other Factors	Total CF	Field Strength	Detector	Limit Distance	Limit Distance Correction	-20 dBc Limit	Margin	Pass/Fail
							dB/m	dB	dB	dB/m	dBuV/m		m	dB	dBuV/m	Δ dB	
1	H	3	Bilog SN1607	57.48	49.20		5.53	0.53	0.00	6.06	55.26	PK	3.00	0.00	81.70	26.44	PASS
1	H	3	Bilog SN1607	99.52	35.20		9.90	0.84	0.00	10.75	45.95	PK	3.00	0.00	81.70	35.75	PASS
1	H	3	Bilog SN1607	107.28	36.80		10.65	0.89	0.00	11.55	48.35	PK	3.00	0.00	81.70	33.35	PASS
1	H	3	Bilog SN1607	167.09	32.00		9.40	0.98	0.00	10.39	42.39	PK	3.00	0.00	81.70	39.31	PASS
1	H	3	Bilog SN1607	208.48	27.30		8.25	1.04	0.00	9.29	36.59	PK	3.00	0.00	81.70	45.11	PASS
1	H	3	Bilog SN1607	245.34	30.00		11.79	1.10	0.00	12.89	42.89	PK	3.00	0.00	81.70	38.81	PASS
1	H	3	Bilog SN1607	380.82	35.30		15.43	1.30	0.00	16.73	52.03	PK	3.00	0.00	81.70	29.67	PASS
1	H	3	Bilog SN1607	787.89	20.30		22.46	1.90	0.00	24.36	44.66	PK	3.00	0.00	81.70	37.04	PASS
1	H	3	Bilog SN1607	855.15	31.30		23.55	1.99	0.00	25.54	56.84	PK	3.00	0.00	81.70	24.86	PASS
1	H	3	Bilog SN1607	931.78	36.00		24.89	2.11	0.00	27.00	63.00	PK	3.00	0.00	81.70	18.70	PASS
1	H	3	Horn SN6276	2500.00	42.60		28.30	3.51	-36.42	-4.61	37.99	PK	3.00	0.00	81.70	43.71	PASS
1	H	3	Horn SN6276	4810.00	22.60	x	32.88	4.96	0.00	37.85	60.45	PK	3.00	0.00	81.70	21.25	PASS
1	H	3	Horn SN6276	5240.00	23.30	x	33.68	5.22	0.00	38.91	62.21	PK	3.00	0.00	81.70	19.49	PASS
1	H	3	Horn SN6276	7230.00	38.90		35.71	6.27	-35.56	6.41	45.31	PK	3.00	0.00	81.70	36.39	PASS
1	H	3	Horn SN6276	9610.00	37.10		37.59	7.37	-35.67	9.29	46.39	PK	3.00	0.00	81.70	35.31	PASS
1	H	3	Horn SN6276	17660.00	38.00	x	44.88	10.46	-36.02	19.33	57.33	PK	3.00	0.00	81.70	24.37	PASS
1	H	1	3160-09	19296.00	52.98		40.26	11.01	-35.81	15.45	68.43	PK	3.00	9.54	91.24	22.81	PASS
1	H	1	3160-09	19296.00	34.05		40.26	11.01	-35.81	15.45	49.50	AV	3.00	9.54	91.24	41.74	PASS
1	H	1	3160-09	21708.00	53.65		40.30	11.91	-35.73	16.48	70.13	PK	3.00	9.54	91.24	21.11	PASS
1	H	1	3160-09	21708.00	35.74		40.30	11.91	-35.73	16.48	52.22	AV	3.00	9.54	91.24	39.02	PASS
1	H	1	3160-09	24120.00	56.09		40.40	12.81	-35.73	17.48	73.57	PK	3.00	9.54	91.24	17.67	PASS
1	H	1	3160-09	24120.00	37.57		40.40	12.81	-35.73	17.48	55.05	AV	3.00	9.54	91.24	36.19	PASS
1	H	1	3160-09	24490.00	57.15		40.40	12.95	-35.73	17.62	74.77	PK	3.00	9.54	91.24	16.47	PASS
1	H	1	3160-09	24490.00	38.00		40.40	12.95	-35.73	17.62	55.62	AV	3.00	9.54	91.24	35.62	PASS

Formulae:

Total CF = Antenna Factor + Cable Factor + Other Factor (Amplifier Gain, filter loss, etc)

Field Strength = SA Reading + Total CF

Limit Distance Correction = 40\*log(d1/d2) for F<30 MHz, 20\*log(d1/d2) for F> 30 MHz:

where d1 is the measurement distance, d2 is the published limit distance

Limit = Specified Limit + Limit Distance Correction

Margin = Limit - Field Strength

\*No out-of-band emissions where measured above the levels noted

<b>Test Report S/N:</b>	052604-515/516KBC
<b>Test Date(s):</b>	28Jun04 - 29Jul04
<b>Test Type:</b>	FCC Part 15.247

E.9.14. Channel 1 Out-of-Band Spurious Emission Field Strengths @ Specified Distance - Vertical Polarization

Channel	Polarity	Measurement Distance	Antenna	Frequency	SA Level	Noise Floor	Antenna Factor	Cable Factor	Other Factors	Total CF	Field Strength	Detector	Limit Distance	Limit Distance Correction	-20 dBc Limit	Margin	Pass/Fail
													m	dB	dBuV/m	Δ dB	
1	V	3	LP-105	0.078	17.37		48.70	0.03	0.00	48.73	66.10	PK	3.00	0.00	76.09	9.99	PASS
1	V	3	LG-105	0.203	1.41		59.86	0.07	0.00	59.94	61.35	PK	3.00	0.00	76.09	14.74	PASS
1	V	3	LG-105	0.485	2.42		58.03	0.09	0.00	58.12	60.54	PK	3.00	0.00	76.09	15.55	PASS
1	V	3	LG-105	1.50	9.04		53.10	0.15	0.00	53.25	62.29	PK	3.00	0.00	76.09	13.80	PASS
1	V	3	LG-105	2.62	7.21		50.69	0.20	0.00	50.89	58.10	PK	3.00	0.00	76.09	17.99	PASS
1	V	3	LG-105	5.48	11.74		44.38	0.31	0.00	44.68	56.42	PK	3.00	0.00	76.09	19.67	PASS
1	V	3	LG-105	27.15	10.24		40.62	0.68	0.00	41.30	51.54	PK	3.00	0.00	76.09	24.55	PASS
1	V	3	Bilog SN1607	99.52	29.60		9.90	0.84	0.00	10.75	40.35	PK	3.00	0.00	76.09	35.74	PASS
1	V	3	Bilog SN1607	208.80	46.80		8.28	1.04	0.00	9.32	56.12	PK	3.00	0.00	76.09	19.97	PASS
1	V	3	Bilog SN1607	245.34	52.50		11.79	1.10	0.00	12.89	65.39	PK	3.00	0.00	76.09	10.70	PASS
1	V	3	Bilog SN1607	449.36	44.80		17.03	1.40	0.00	18.43	63.23	PK	3.00	0.00	76.09	12.86	PASS
1	V	3	Bilog SN1607	736.16	23.70		22.93	1.82	0.00	24.75	48.45	PK	3.00	0.00	76.09	27.64	PASS
1	V	3	Bilog SN1607	772.70	44.40		22.57	1.87	0.00	24.45	68.85	PK	3.00	0.00	76.09	7.24	PASS
1	V	3	Horn SN6276	3200.00	43.50		30.48	4.04	-35.93	-1.40	42.10	PK	3.00	0.00	76.09	33.99	PASS
1	V	3	Horn SN6276	4810.00	47.00		32.88	4.96	-35.30	2.54	49.54	PK	3.00	0.00	76.09	26.55	PASS
1	V	3	Horn SN6276	5260.00	40.10		33.72	5.23	-35.34	3.61	43.71	PK	3.00	0.00	76.09	32.38	PASS
1	V	3	Horn SN6276	5720.00	41.60		34.19	5.44	-35.38	4.25	45.85	PK	3.00	0.00	76.09	30.24	PASS
1	V	3	Horn SN6276	5770.00	44.80		34.21	5.45	-35.38	4.28	49.08	PK	3.00	0.00	76.09	27.01	PASS
1	V	3	Horn SN6276	7520.00	40.40		36.32	6.43	-35.53	7.21	47.61	PK	3.00	0.00	76.09	28.48	PASS
1	V	3	Horn SN6276	8360.00	37.60		37.06	6.79	-35.60	8.25	45.85	PK	3.00	0.00	76.09	30.24	PASS
1	V	3	Horn SN6276	9610.00	36.60		37.59	7.37	-35.71	9.25	45.85	PK	3.00	0.00	76.09	30.24	PASS

Formulae:

Total CF = Antenna Factor + Cable Factor + Other Factor (Amplifier Gain, filter loss, etc)

Field Strength = SA Reading + Total CF

Limit Distance Correction = 40\*log(d1/d2) for F<30 MHz, 20\*log(d1/d2) for F> 30 MHz:

where d1 is the measurement distance, d2 is the published limit distance

Limit = Specified Limit + Limit Distance Correction

Margin = Limit - Field Strength

\*No out-of-band emissions where measured above the levels noted

Continued

<b>Test Report S/N:</b>	052604-515/516KBC
<b>Test Date(s):</b>	28Jun04 - 29Jul04
<b>Test Type:</b>	FCC Part 15.247

Continued

Channel	Polarity	Measurement Distance	Antenna	Frequency	SA Level	Noise Floor	Antenna Factor	Cable Factor	Other Factors	Total CF	Field Strength	Detector	Limit Distance	Limit Distance Correction	-20 dBc Limit	Margin	Pass/Fail
							dB/m	dB	dB	dB/m	dBuV/m		m	dB	dBuV/m	Δ dB	
1	V	3	Horn SN6276	12640.00	36.90		38.71	8.68	-36.79	10.59	47.49	PK	3.00	0.00	76.09	28.60	PASS
1	V	3	Horn SN6276	15740.00	38.20		37.56	9.77	-36.53	10.80	49.00	PK	3.00	0.00	76.09	27.09	PASS
1	V	3	Horn SN6276	17770.00	37.60	x	45.70	10.30	-36.35	19.65	57.25	PK	3.00	0.00	76.09	18.84	PASS
1	V	1	3160-09	18820.00	53.92	x	40.20	11.05	-35.87	15.38	69.30	PK	3.00	9.54	85.63	16.33	PASS
1	V	1	3160-09	18820.00	33.66	x	40.20	11.05	-35.87	15.38	49.04	AV	3.00	9.54	85.63	36.59	PASS
1	V	1	3160-09	19296.00	52.65		40.26	11.01	-35.81	15.45	68.10	PK	3.00	9.54	85.63	17.53	PASS
1	V	1	3160-09	19296.00	33.76		40.26	11.01	-35.81	15.45	49.21	AV	3.00	9.54	85.63	36.42	PASS
1	V	1	3160-09	21708.00	53.27		40.30	11.91	-35.73	16.48	69.75	PK	3.00	9.54	85.63	15.88	PASS
1	V	1	3160-09	21708.00	36.04		40.30	11.91	-35.73	16.48	52.52	AV	3.00	9.54	85.63	33.11	PASS
1	V	1	3160-09	24120.00	56.03		40.40	12.81	-35.73	17.48	73.51	PK	3.00	9.54	85.63	12.12	PASS
1	V	1	3160-09	24120.00	37.21		40.40	12.81	-35.73	17.48	54.69	AV	3.00	9.54	85.63	30.94	PASS
1	V	1	3160-09	24550.00	56.31	x	40.40	12.97	-35.73	17.64	73.95	PK	3.00	9.54	85.63	11.68	PASS
1	V	1	3160-09	24550.00	38.30	x	40.40	12.97	-35.73	17.64	55.94	AV	3.00	9.54	85.63	29.69	PASS

Formulae:

Total CF = Antenna Factor + Cable Factor + Other Factor (Amplifier Gain, filter loss, etc)

Field Strength = SA Reading + Total CF

Limit Distance Correction =  $40 \cdot \log(d1/d2)$  for  $F < 30$  MHz,  $20 \cdot \log(d1/d2)$  for  $F > 30$  MHz:

where d1 is the measurement distance, d2 is the published limit distance

Limit = Specified Limit + Limit Distance Correction

Margin = Limit - Field Strength

\*No out-of-band emissions where measured above the levels noted

<b>Test Report S/N:</b>	052604-515/516KBC
<b>Test Date(s):</b>	28Jun04 - 29Jul04
<b>Test Type:</b>	FCC Part 15.247

E.9.15. Channel 6 Out-of-Band Spurious Emission Field Strengths @ Specified Distance – Horizontal Polarization

Channel	Polarity	Measurement Distance	Antenna	Frequency	SA Level	Noise Floor	Antenna Factor	Cable Factor	Other Factors	Total CF	Field Strength	Detector	Limit Distance	Limit Distance Correction	-20 dBc Limit	Margin	Pass/Fail
							dB/m	dB	dB	dB/m	dBuV/m		m	dB	dBuV/m	Δ dB	
6	H	3	Bilog SN1607	60.70	29.20		5.03	0.56	0.00	5.59	34.79	PK	3.00	0.00	81.67	46.88	PASS
6	H	3	Bilog SN1607	107.28	36.50		10.65	0.89	0.00	11.55	48.05	PK	3.00	0.00	81.67	33.62	PASS
6	H	3	Bilog SN1607	149.96	34.10		10.70	0.96	0.00	11.66	45.76	PK	3.00	0.00	81.67	35.91	PASS
6	H	3	Bilog SN1607	208.48	29.70		8.25	1.04	0.00	9.29	38.99	PK	3.00	0.00	81.67	42.68	PASS
6	H	3	Bilog SN1607	245.34	34.80		11.79	1.10	0.00	12.89	47.69	PK	3.00	0.00	81.67	33.98	PASS
6	H	3	Bilog SN1607	786.92	24.50		22.47	1.89	0.00	24.36	48.86	PK	3.00	0.00	81.67	32.81	PASS
6	H	3	Bilog SN1607	929.51	19.50		24.83	2.10	0.00	26.94	46.44	PK	3.00	0.00	81.67	35.23	PASS
6	H	3	Horn SN6276	2750.00	38.60		29.15	3.69	-36.38	-3.53	35.07	PK	3.00	0.00	81.67	46.60	PASS
6	H	3	Horn SN6276	3240.00	37.00		30.58	4.06	-36.12	-1.48	35.52	PK	3.00	0.00	81.67	46.15	PASS
6	H	3	Horn SN6276	4860.00	36.70		32.99	5.02	-35.46	2.55	39.25	PK	3.00	0.00	81.67	42.42	PASS
6	H	3	Horn SN6276	5260.00	45.20		33.72	5.23	-35.47	3.47	48.67	PK	3.00	0.00	81.67	33.00	PASS
6	H	3	Horn SN6276	5770.00	37.20		34.21	5.45	-35.50	4.16	41.36	PK	3.00	0.00	81.67	40.31	PASS
6	H	3	Horn SN6276	8280.00	38.40		36.98	6.75	-35.61	8.11	46.51	PK	3.00	0.00	81.67	35.16	PASS
6	H	3	Horn SN6276	8360.00	42.30		37.06	6.79	-35.62	8.24	50.54	PK	3.00	0.00	81.67	31.13	PASS
6	H	3	Horn SN6276	17090.00	39.20		41.24	10.38	-36.09	15.54	54.74	PK	3.00	0.00	81.67	26.93	PASS
6	H	1	3160-09	19496.00	52.56		40.30	11.28	-35.79	15.79	68.35	PK	3.00	9.54	91.21	22.86	PASS
6	H	1	3160-09	19496.00	33.91		40.30	11.28	-35.79	15.79	49.70	AV	3.00	9.54	91.21	41.51	PASS
6	H	1	3160-09	21240.00	54.98	x	40.30	11.73	-35.73	16.31	71.29	PK	3.00	9.54	91.21	19.93	PASS
6	H	1	3160-09	21240.00	35.72	x	40.30	11.73	-35.73	16.31	52.03	AV	3.00	9.54	91.21	39.19	PASS
6	H	1	3160-09	21933.00	54.66		40.30	11.99	-35.73	16.57	71.23	PK	3.00	9.54	91.21	19.99	PASS
6	H	1	3160-09	21933.00	36.27		40.30	11.99	-35.73	16.57	52.84	AV	3.00	9.54	91.21	38.38	PASS
6	H	1	3160-09	24370.00	57.10		40.40	12.90	-35.73	17.58	74.68	PK	3.00	9.54	91.21	16.54	PASS
6	H	1	3160-09	24370.00	37.88		40.40	12.90	-35.73	17.58	55.46	AV	3.00	9.54	91.21	35.76	PASS
6	H	1	3160-09	24420.00	56.93	x	40.40	12.92	-35.73	17.60	74.53	PK	3.00	9.54	91.21	16.69	PASS
6	H	1	3160-09	24420.00	37.73	x	40.40	12.92	-35.73	17.60	55.33	AV	3.00	9.54	91.21	35.89	PASS

Formulae:

Total CF = Antenna Factor + Cable Factor + Other Factor (Amplifier Gain, filter loss, etc)

Field Strength = SA Reading + Total CF

Limit Distance Correction = 40\*log(d1/d2) for F<30 MHz, 20\*log(d1/d2) for F> 30 MHz:  
where d1 is the measurement distance, d2 is the published limit distance

Limit = Specified Limit + Limit Distance Correction

Margin = Limit - Field Strength

\*No out-of-band emissions where measured above the levels noted

<b>Test Report S/N:</b>	052604-515/516KBC
<b>Test Date(s):</b>	28Jun04 - 29Jul04
<b>Test Type:</b>	FCC Part 15.247

E.9.16. Channel 6 Out-of-Band Spurious Emission Field Strengths @ Specified Distance - Vertical Polarization

Channel	Polarity	Measurement Distance	Antenna	Frequency	SA Level	Noise Floor	Antenna Factor	Cable Factor	Other Factors	Total CF	Field Strength	Detector	Limit Distance	Limit Distance Correction	-20 dBc Limit	Margin	Pass/Fail
													m	dB	dBuV/m	Δ dB	
6	V	3	LP-105	0.08	17.57		48.71	0.05	0.00	48.76	66.33	PK	3.00	0.00	75.37	9.04	PASS
6	V	3	LG-105	2.03	9.04		52.21	0.17	0.00	52.39	61.43	PK	3.00	0.00	75.37	13.94	PASS
6	V	3	LG-105	0.83	2.38		57.38	0.11	0.00	57.49	59.87	PK	3.00	0.00	75.37	15.50	PASS
6	V	3	LG-105	1.50	8.52		53.11	0.15	0.00	53.26	61.78	PK	3.00	0.00	75.37	13.59	PASS
6	V	3	LG-105	3.22	8.34		49.31	0.23	0.00	49.54	57.88	PK	3.00	0.00	75.37	17.49	PASS
6	V	3	LG-105	5.63	12.44		44.09	0.31	0.00	44.40	56.84	PK	3.00	0.00	75.37	18.53	PASS
6	V	3	LG-105	17.80	9.89		41.04	0.55	0.00	41.59	51.48	PK	3.00	0.00	75.37	23.89	PASS
6	V	3	Bilog SN1607	57.48	30.80		5.53	0.53	0.00	6.06	36.86	PK	3.00	0.00	75.37	38.51	PASS
6	V	3	Bilog SN1607	99.52	28.50		9.90	0.84	0.00	10.75	39.25	PK	3.00	0.00	75.37	36.12	PASS
6	V	3	Bilog SN1607	103.72	27.90		10.33	0.88	0.00	11.21	39.11	PK	3.00	0.00	75.37	36.26	PASS
6	V	3	Bilog SN1607	138.96	37.30		11.14	0.94	0.00	12.08	49.38	PK	3.00	0.00	75.37	25.99	PASS
6	V	3	Bilog SN1607	166.77	24.50		9.43	0.98	0.00	10.41	34.91	PK	3.00	0.00	75.37	40.46	PASS
6	V	3	Bilog SN1607	196.19	31.70		8.47	1.03	0.00	9.49	41.19	PK	3.00	0.00	75.37	34.18	PASS
6	V	3	Bilog SN1607	196.52	29.70		8.44	1.03	0.00	9.47	39.17	PK	3.00	0.00	75.37	36.20	PASS
6	V	3	Bilog SN1607	244.37	56.10		11.68	1.10	0.00	12.78	68.88	PK	3.00	0.00	75.37	6.49	PASS
6	V	3	Bilog SN1607	246.96	28.50		11.97	1.10	0.00	13.07	41.57	PK	3.00	0.00	75.37	33.80	PASS
6	V	3	Bilog SN1607	306.45	27.50		13.40	1.19	0.00	14.58	42.08	PK	3.00	0.00	75.37	33.29	PASS
6	V	3	Bilog SN1607	772.70	37.20		22.57	1.87	0.00	24.45	61.65	PK	3.00	0.00	75.37	13.72	PASS
6	V	3	Bilog SN1607	952.47	34.80		25.36	2.14	0.00	27.50	62.30	PK	3.00	0.00	75.37	13.07	PASS
6	V	3	Horn SN6276	2830.00	37.90		29.42	3.75	-36.33	-3.16	34.74	PK	3.00	0.00	75.37	40.63	PASS
6	V	3	Horn SN6276	5240.00	37.30		33.68	5.22	-35.47	3.43	40.73	PK	3.00	0.00	75.37	34.64	PASS
6	V	3	Horn SN6276	5770.00	40.10		34.21	5.45	-35.50	4.16	44.26	PK	3.00	0.00	75.37	31.11	PASS
6	V	3	Horn SN6276	7520.00	37.80		36.32	6.43	-35.58	7.17	44.97	PK	3.00	0.00	75.37	30.40	PASS

Formulae:

Total CF = Antenna Factor + Cable Factor + Other Factor (Amplifier Gain, filter loss, etc)

Field Strength = SA Reading + Total CF

Limit Distance Correction =  $40 \cdot \log(d1/d2)$  for  $F < 30$  MHz,  $20 \cdot \log(d1/d2)$  for  $F > 30$  MHz:

where d1 is the measurement distance, d2 is the published limit distance

Limit = Specified Limit + Limit Distance Correction

Margin = Limit - Field Strength

\*No out-of-band emissions where measured above the levels noted

Continued



<b>Test Report S/N:</b>	052604-515/516KBC
<b>Test Date(s):</b>	28Jun04 - 29Jul04
<b>Test Type:</b>	FCC Part 15.247

Continued

Channel	Polarity	Measurement Distance	Antenna	Frequency	SA Level	Noise Floor	Antenna Factor	Cable Factor	Other Factors	Total CF	Field Strength	Detector	Limit Distance	Limit Distance Correction	-20 dBc Limit	Margin	Pass/Fail
							dB/m	dB	dB	dB/m	dBuV/m		m	dB	dBuV/m	Δ dB	
6	V	3	Horn SN6276	9720.00	36.80		37.68	7.34	-35.71	9.31	46.11	PK	3.00	0.00	75.37	29.26	PASS
6	V	3	Horn SN6276	16480.00	38.30	x	38.45	10.25	-36.16	12.54	50.84	PK	3.00	0.00	75.37	24.53	PASS
6	V	1	3160-09	19190.00	54.26	x	40.24	10.91	-35.83	15.32	69.58	PK	3.00	9.54	84.91	15.33	PASS
6	V	1	3160-09	19190.00	33.78	x	40.24	10.91	-35.83	15.32	49.10	AV	3.00	9.54	84.91	35.81	PASS
6	V	1	3160-09	19496.00	52.89		40.30	11.28	-35.79	15.79	68.68	PK	3.00	9.54	84.91	16.23	PASS
6	V	1	3160-09	19496.00	33.88		40.30	11.28	-35.79	15.79	49.67	AV	3.00	9.54	84.91	35.24	PASS
6	V	1	3160-09	21933.00	53.99		40.30	11.99	-35.73	16.57	70.56	PK	3.00	9.54	84.91	14.36	PASS
6	V	1	3160-09	21933.00	36.23		40.30	11.99	-35.73	16.57	52.80	AV	3.00	9.54	84.91	32.12	PASS
6	V	1	3160-09	24370.00	55.56		40.40	12.90	-35.73	17.58	73.14	PK	3.00	9.54	84.91	11.78	PASS
6	V	1	3160-09	24370.00	37.88		40.40	12.90	-35.73	17.58	55.46	AV	3.00	9.54	84.91	29.46	PASS
6	V	1	3160-09	24400.00	56.66	x	40.40	12.91	-35.73	17.59	74.25	PK	3.00	9.54	84.91	10.66	PASS
6	V	1	3160-09	24400.00	37.87	x	40.40	12.91	-35.73	17.59	55.46	AV	3.00	9.54	84.91	29.45	PASS

**Formulae:**

Total CF = Antenna Factor + Cable Factor + Other Factor (Amplifier Gain, filter loss, etc)

Field Strength = SA Reading + Total CF

Limit Distance Correction =  $40 \cdot \log(d1/d2)$  for  $F < 30$  MHz,  $20 \cdot \log(d1/d2)$  for  $F > 30$  MHz:

where d1 is the measurement distance, d2 is the published limit distance

Limit = Specified Limit + Limit Distance Correction

Margin = Limit - Field Strength

\*No out-of-band emissions where measured above the levels noted

<b>Test Report S/N:</b>	052604-515/516KBC
<b>Test Date(s):</b>	28Jun04 - 29Jul04
<b>Test Type:</b>	FCC Part 15.247

E.9.17. Channel 11 Out-of-Band Spurious Emission Field Strengths @ Specified Distance – Horizontal Polarization

Channel	Polarity	Measurement Distance	Antenna	Frequency	SA Level	Noise Floor	Antenna Factor	Cable Factor	Other Factors	Total CF	Field Strength	Detector	Limit Distance	Limit Distance Correction	-20 dBc Limit	Margin	Pass/Fail
11	H	3	Bilog SN1607	57.80	48.10		5.45	0.54	0.00	5.99	54.09	PK	3.00	0.00	82.23	28.14	PASS
11	H	3	Bilog SN1607	101.13	38.90		10.10	0.86	0.00	10.96	49.86	PK	3.00	0.00	82.23	32.37	PASS
11	H	3	Bilog SN1607	141.55	31.30		11.07	0.95	0.00	12.01	43.31	PK	3.00	0.00	82.23	38.92	PASS
11	H	3	Bilog SN1607	208.80	31.20		8.28	1.04	0.00	9.32	40.52	PK	3.00	0.00	82.23	41.71	PASS
11	H	3	Bilog SN1607	297.72	29.20		13.28	1.17	0.00	14.45	43.65	PK	3.00	0.00	82.23	38.58	PASS
11	H	3	Bilog SN1607	381.14	44.00		15.45	1.30	0.00	16.74	60.74	PK	3.00	0.00	82.23	21.49	PASS
11	H	3	Bilog SN1607	772.70	28.40		22.57	1.87	0.00	24.45	52.85	PK	3.00	0.00	82.23	29.38	PASS
11	H	3	Bilog SN1607	944.39	31.30		25.21	2.13	0.00	27.34	58.64	PK	3.00	0.00	82.23	23.59	PASS
11	H	3	Horn SN6276	2810.00	37.50		29.35	3.74	-36.34	-3.25	34.25	PK	3.00	0.00	82.23	47.98	PASS
11	H	3	Horn SN6276	4900.00	39.50		33.08	5.05	-35.46	2.68	42.18	PK	3.00	0.00	82.23	40.05	PASS
11	H	3	Horn SN6276	5260.00	45.80		33.72	5.23	-35.47	3.47	49.27	PK	3.00	0.00	82.23	32.96	PASS
11	H	3	Horn SN6276	8280.00	39.30		36.98	6.75	-35.61	8.11	47.41	PK	3.00	0.00	82.23	34.82	PASS
11	H	3	Horn SN6276	8360.00	42.10		37.06	6.79	-35.62	8.24	50.34	PK	3.00	0.00	82.23	31.89	PASS
11	H	3	Horn SN6276	9820.00	39.00		37.76	7.44	-35.77	9.42	48.42	PK	3.00	0.00	82.23	33.81	PASS
11	H	3	Horn SN6276	15920.00	38.90	x	37.38	9.83	-36.23	10.98	49.88	PK	3.00	0.00	82.23	32.35	PASS
11	H	1	3160-09	18810.00	53.72	x	40.20	11.15	-35.87	15.48	69.20	PK	3.00	9.54	91.77	22.58	PASS
11	H	1	3160-09	18810.00	33.94	x	40.20	11.15	-35.87	15.48	49.42	AV	3.00	9.54	91.77	42.36	PASS
11	H	1	3160-09	19696.00	53.67		40.30	11.42	-35.76	15.95	69.62	PK	3.00	9.54	91.77	22.15	PASS
11	H	1	3160-09	19696.00	33.44		40.30	11.42	-35.76	15.95	49.39	AV	3.00	9.54	91.77	42.38	PASS
11	H	1	3160-09	22158.00	53.69		40.33	12.08	-35.73	16.68	70.37	PK	3.00	9.54	91.77	21.40	PASS
11	H	1	3160-09	22158.00	35.90		40.33	12.08	-35.73	16.68	52.58	AV	3.00	9.54	91.77	39.19	PASS
11	H	1	3160-09	24460.00	56.88	x	40.40	12.94	-35.73	17.61	74.49	PK	3.00	9.54	91.77	17.28	PASS
11	H	1	3160-09	24460.00	37.32	x	40.40	12.94	-35.73	17.61	54.93	AV	3.00	9.54	91.77	36.84	PASS
11	H	1	3160-09	24620.00	55.75		40.40	13.00	-35.73	17.67	73.42	PK	3.00	9.54	91.77	18.35	PASS
11	H	1	3160-09	24620.00	37.57		40.40	13.00	-35.73	17.67	55.24	AV	3.00	9.54	91.77	36.53	PASS

Formulae:

Total CF = Antenna Factor + Cable Factor + Other Factor (Amplifier Gain, filter loss, etc)

Field Strength = SA Reading + Total CF

Limit Distance Correction = 40\*log(d1/d2) for F<30 MHz, 20\*log(d1/d2) for F> 30 MHz:  
 where d1 is the measurement distance, d2 is the published limit distance

Limit = Specified Limit + Limit Distance Correction

Margin = Limit - Field Strength

\*No out-of-band emissions where measured above the levels noted

<b>Test Report S/N:</b>	052604-515/516KBC
<b>Test Date(s):</b>	28Jun04 - 29Jul04
<b>Test Type:</b>	FCC Part 15.247

E.9.18. Channel 11 Out-of-Band Spurious Emission Field Strengths @ Specified Distance – Vertical Polarization

Channel	Polarity	Measurement Distance	Antenna	Frequency	SA Level	Noise Floor	Antenna Factor	Cable Factor	Other Factors	Total CF	Field Strength	Detector	Limit Distance	Limit Distance Correction	-20 dBc Limit	Margin	Pass/Fail
							dB/m	dB	dB	dB/m	dBuV/m		m	dB	dBuV/m	Δ dB	
11	V	3	LP-105	0.08	19.50		48.79	0.04	0.00	48.83	68.33	PK	3.00	0.00	76.64	8.31	PASS
11	V	3	LG-105	0.20	1.04		59.88	0.07	0.00	59.95	60.99	PK	3.00	0.00	76.64	15.65	PASS
11	V	3	LG-105	0.79	1.46		57.46	0.12	0.00	57.57	59.03	PK	3.00	0.00	76.64	17.61	PASS
11	V	3	LG-105	1.44	8.37		53.25	0.15	0.00	53.40	61.77	PK	3.00	0.00	76.64	14.87	PASS
11	V	3	LG-105	4.05	10.60		47.10	0.26	0.00	47.36	57.96	PK	3.00	0.00	76.64	18.68	PASS
11	V	3	LG-105	5.26	10.77		44.79	0.30	0.00	45.09	55.86	PK	3.00	0.00	76.64	20.78	PASS
11	V	3	LG-105	13.95	9.95		40.60	0.50	0.00	41.09	51.04	PK	3.00	0.00	76.64	25.60	PASS
11	V	3	Bilog SN1607	138.96	37.30		11.14	0.94	0.00	12.08	49.38	PK	3.00	0.00	76.64	27.26	PASS
11	V	3	Bilog SN1607	149.63	56.50		10.72	0.96	0.00	11.68	68.18	PK	3.00	0.00	76.64	8.46	PASS
11	V	3	Bilog SN1607	164.83	39.20		9.57	0.98	0.00	10.54	49.74	PK	3.00	0.00	76.64	26.90	PASS
11	V	3	Bilog SN1607	208.48	44.90		8.25	1.04	0.00	9.29	54.19	PK	3.00	0.00	76.64	22.45	PASS
11	V	3	Bilog SN1607	245.02	44.80		11.75	1.10	0.00	12.85	57.65	PK	3.00	0.00	76.64	18.99	PASS
11	V	3	Bilog SN1607	794.04	35.60		22.51	1.90	0.00	24.42	60.02	PK	3.00	0.00	76.64	16.62	PASS
11	V	3	Horn SN6276	2810.00	37.20		29.35	3.74	-36.34	-3.25	33.95	PK	3.00	0.00	76.64	42.69	PASS
11	V	3	Horn SN6276	5270.00	36.40		33.73	5.24	-35.47	3.49	39.89	PK	3.00	0.00	76.64	36.75	PASS
11	V	3	Horn SN6276	5770.00	42.50		34.21	5.45	-35.50	4.16	46.66	PK	3.00	0.00	76.64	29.98	PASS
11	V	3	Horn SN6276	9820.00	36.60		37.76	7.44	-35.77	9.42	46.02	PK	3.00	0.00	76.64	30.62	PASS
11	V	3	Horn SN6276	16680.00	39.00	x	39.29	10.24	-36.14	13.40	52.40	PK	3.00	0.00	76.64	24.24	PASS
11	V	1	3160-09	19696.00	53.07		40.30	11.42	-35.76	15.95	69.02	PK	3.00	9.54	86.18	17.16	PASS
11	V	1	3160-09	19696.00	33.28		40.30	11.42	-35.76	15.95	49.23	AV	3.00	9.54	86.18	36.95	PASS
11	V	1	3160-09	20660.00	55.02	x	40.30	11.74	-35.73	16.31	71.33	PK	3.00	9.54	86.18	14.85	PASS
11	V	1	3160-09	20660.00	35.18	x	40.30	11.74	-35.73	16.31	51.49	AV	3.00	9.54	86.18	34.69	PASS
11	V	1	3160-09	22158.00	54.12		40.33	12.08	-35.73	16.68	70.80	PK	3.00	9.54	86.18	15.38	PASS
11	V	1	3160-09	22158.00	35.80		40.33	12.08	-35.73	16.68	52.48	AV	3.00	9.54	86.18	33.70	PASS
11	V	1	3160-09	23950.00	57.28	x	40.40	12.75	-35.73	17.42	74.70	PK	3.00	9.54	86.18	11.48	PASS
11	V	1	3160-09	23950.00	36.43	x	40.40	12.75	-35.73	17.42	53.85	AV	3.00	9.54	86.18	32.33	PASS
11	V	1	3160-09	24620.00	55.73		40.40	13.00	-35.73	17.67	73.40	PK	3.00	9.54	86.18	12.78	PASS

Formulae:

Total CF = Antenna Factor + Cable Factor + Other Factor (Amplifier Gain, filter loss, etc)

Field Strength = SA Reading + Total CF

Limit Distance Correction = 40\*log(d1/d2) for F<30 MHz, 20\*log(d1/d2) for F> 30 MHz:

where d1 is the measurement distance, d2 is the published limit distance

Limit = Specified Limit + Limit Distance Correction

Margin = Limit - Field Strength

\*No out-of-band emissions where measured above the levels noted

<b>Test Report S/N:</b>	052604-515/516KBC
<b>Test Date(s):</b>	28Jun04 - 29Jul04
<b>Test Type:</b>	FCC Part 15.247

**E.10. PASS/FAIL**

In reference to the results outlined in E.9, the DUT passes the requirements as stated in the reference standards as follows:  
 FCC 15.247 (c): All emissions within any 100kHz bandwidth outside the operating frequency band are greater than 20 dB below the maximum 100 kHz bandwidth signal within the operating band.

**E.11. SIGN-OFF**

I attest to the accuracy of the data. All measurements reported herein were performed by me and are correct to the best of my knowledge and belief. I assume full responsibility for the completeness of these measurements.



\_\_\_\_\_  
 Russell Pipe  
 Senior Compliance Technologist  
 Celltech Labs Inc.

\_\_\_\_\_  
 29Jul04  
 Date

Test Report S/N:	052604-515/516KBC
Test Date(s):	28Jun04 - 29Jul04
Test Type:	FCC Part 15.247

### Appendix F - Restricted Band Emissions Measurement

<b>F.1. REFERENCES</b>	
<b>Normative Reference Standard</b>	FCC CFR 47 §15.205 (a) (b), FCC CFR 47 §15.209 (a)
<b>Procedure Reference</b>	FCC 97-114

### F.2. LIMITS

FCC CFR 47 §15.205	(a) Except as shown in paragraph (d) of this section, only spurious emissions are permitted in any of the frequency bands listed below:																																																																								
	<table border="1"> <thead> <tr> <th>MHz</th> <th>MHz</th> <th>MHz</th> <th>GHz</th> </tr> </thead> <tbody> <tr><td>0.090–0.110</td><td>16.42–16.423</td><td>399.9–410</td><td>4.5–5.15</td></tr> <tr><td>10.495–0.505</td><td>16.69475–16.69525</td><td>608–614</td><td>5.35–5.46</td></tr> <tr><td>2.1735–2.1905</td><td>16.80425–16.80475</td><td>960–1240</td><td>7.25–7.75</td></tr> <tr><td>4.125–4.128</td><td>25.5–25.67</td><td>1300–1427</td><td>8.025–8.5</td></tr> <tr><td>4.17725–4.17775</td><td>37.5–38.25</td><td>1435–1626.5</td><td>9.0–9.2</td></tr> <tr><td>4.20725–4.20775</td><td>73–74.6</td><td>1645.5–1646.5</td><td>9.3–9.5</td></tr> <tr><td>6.215–6.218</td><td>74.8–75.2</td><td>1660–1710</td><td>10.6–12.7</td></tr> <tr><td>6.26775–6.26825</td><td>108–121.94</td><td>1718.8–1722.2</td><td>13.25–13.4</td></tr> <tr><td>6.31175–6.31225</td><td>123–138</td><td>2200–2300</td><td>14.47–14.5</td></tr> <tr><td>8.291–8.294</td><td>149.9–150.05</td><td>2310–2390</td><td>15.35–16.2</td></tr> <tr><td>8.362–8.366</td><td>156.52475–156.52525</td><td>2483.5–2500</td><td>17.7–21.4</td></tr> <tr><td>8.37625–8.38675</td><td>156.7–156.9</td><td>2655–2900</td><td>22.01–23.12</td></tr> <tr><td>8.41425–8.41475</td><td>162.0125–167.17</td><td>3260–3267</td><td>23.6–24.0</td></tr> <tr><td>12.29–12.293</td><td>167.72–173.2</td><td>3332–3339</td><td>31.2–31.8</td></tr> <tr><td>12.51975–12.52025</td><td>240–285</td><td>3345.8–3358</td><td>36.43–36.5</td></tr> <tr><td>12.57675–12.57725</td><td>322–335.4</td><td>3600–4400</td><td>(<sup>2</sup>)</td></tr> <tr><td>13.36–13.41</td><td></td><td></td><td></td></tr> </tbody> </table> <p><sup>1</sup> Until February 1, 1999, this restricted band shall be 0.490–0.510 MHz.  <sup>2</sup> Above 38.6</p>	MHz	MHz	MHz	GHz	0.090–0.110	16.42–16.423	399.9–410	4.5–5.15	10.495–0.505	16.69475–16.69525	608–614	5.35–5.46	2.1735–2.1905	16.80425–16.80475	960–1240	7.25–7.75	4.125–4.128	25.5–25.67	1300–1427	8.025–8.5	4.17725–4.17775	37.5–38.25	1435–1626.5	9.0–9.2	4.20725–4.20775	73–74.6	1645.5–1646.5	9.3–9.5	6.215–6.218	74.8–75.2	1660–1710	10.6–12.7	6.26775–6.26825	108–121.94	1718.8–1722.2	13.25–13.4	6.31175–6.31225	123–138	2200–2300	14.47–14.5	8.291–8.294	149.9–150.05	2310–2390	15.35–16.2	8.362–8.366	156.52475–156.52525	2483.5–2500	17.7–21.4	8.37625–8.38675	156.7–156.9	2655–2900	22.01–23.12	8.41425–8.41475	162.0125–167.17	3260–3267	23.6–24.0	12.29–12.293	167.72–173.2	3332–3339	31.2–31.8	12.51975–12.52025	240–285	3345.8–3358	36.43–36.5	12.57675–12.57725	322–335.4	3600–4400	( <sup>2</sup> )	13.36–13.41			
MHz	MHz	MHz	GHz																																																																						
0.090–0.110	16.42–16.423	399.9–410	4.5–5.15																																																																						
10.495–0.505	16.69475–16.69525	608–614	5.35–5.46																																																																						
2.1735–2.1905	16.80425–16.80475	960–1240	7.25–7.75																																																																						
4.125–4.128	25.5–25.67	1300–1427	8.025–8.5																																																																						
4.17725–4.17775	37.5–38.25	1435–1626.5	9.0–9.2																																																																						
4.20725–4.20775	73–74.6	1645.5–1646.5	9.3–9.5																																																																						
6.215–6.218	74.8–75.2	1660–1710	10.6–12.7																																																																						
6.26775–6.26825	108–121.94	1718.8–1722.2	13.25–13.4																																																																						
6.31175–6.31225	123–138	2200–2300	14.47–14.5																																																																						
8.291–8.294	149.9–150.05	2310–2390	15.35–16.2																																																																						
8.362–8.366	156.52475–156.52525	2483.5–2500	17.7–21.4																																																																						
8.37625–8.38675	156.7–156.9	2655–2900	22.01–23.12																																																																						
8.41425–8.41475	162.0125–167.17	3260–3267	23.6–24.0																																																																						
12.29–12.293	167.72–173.2	3332–3339	31.2–31.8																																																																						
12.51975–12.52025	240–285	3345.8–3358	36.43–36.5																																																																						
12.57675–12.57725	322–335.4	3600–4400	( <sup>2</sup> )																																																																						
13.36–13.41																																																																									
	(b) Except as provided in paragraphs (d) and (e), the field strength of emissions appearing within these frequency bands shall not exceed the limits shown in 15.209. At frequencies equal to or less than 1000 MHz, compliance with the limits in Section 15.209 shall be demonstrated using measurement instrumentation employing a CISPR quasi-peak detector. Above 1000 MHz, compliance with the emission limits in Section 15.209 shall be demonstrated based on the average value of the measured emissions. The provisions of 15.35 apply to these measurements.																																																																								

FCC CFR 47 §15.209	(a) Except as provided elsewhere in this Subpart, the emissions from an intentional radiator shall not exceed the field strength levels specified in the following table:																											
	<table border="1"> <thead> <tr> <th>Frequency</th> <th>Field Strength</th> <th>Measurement Distance</th> </tr> <tr> <th>MHz</th> <th>uV/m</th> <th>Meters</th> </tr> </thead> <tbody> <tr><td>.009 – 0.490</td><td>2400/F(kHz)</td><td>300</td></tr> <tr><td>0.490 – 1.705</td><td>24000/F(kHz)</td><td>30</td></tr> <tr><td>1.705 – 30.0</td><td>30</td><td>30</td></tr> <tr><td>30 – 88</td><td>100</td><td>3</td></tr> <tr><td>88 – 216</td><td>150</td><td>3</td></tr> <tr><td>216 - 960</td><td>200</td><td>3</td></tr> <tr><td>Above 960</td><td>500</td><td>3</td></tr> </tbody> </table>	Frequency	Field Strength	Measurement Distance	MHz	uV/m	Meters	.009 – 0.490	2400/F(kHz)	300	0.490 – 1.705	24000/F(kHz)	30	1.705 – 30.0	30	30	30 – 88	100	3	88 – 216	150	3	216 - 960	200	3	Above 960	500	3
Frequency	Field Strength	Measurement Distance																										
MHz	uV/m	Meters																										
.009 – 0.490	2400/F(kHz)	300																										
0.490 – 1.705	24000/F(kHz)	30																										
1.705 – 30.0	30	30																										
30 – 88	100	3																										
88 – 216	150	3																										
216 - 960	200	3																										
Above 960	500	3																										
	(b) In the emission table above, the tighter limit applies at the band edges.																											

<b>Test Report S/N:</b>	052604-515/516KBC
<b>Test Date(s):</b>	28Jun04 - 29Jul04
<b>Test Type:</b>	FCC Part 15.247

F.3. ENVIRONMENTAL CONDITIONS	
<b>Temperature</b>	27.4 +/- 2 °C
<b>Humidity</b>	33 +/- 2 %
<b>Barometric Pressure</b>	96.24 +/- 0.2 kPa

F.4. EQUIPMENT LIST					
ASSET NUMBER	MANUFACTURER	MODEL	DESCRIPTION	LAST CAL	CAL DUE
00072	EMCO	2075	Mini-mast	n/a	n/a
00073	EMCO	2080	Turn Table	n/a	n/a
00071	EMCO	2090	Multi-Device Controller	n/a	n/a
00200	Empire	LG-105	Large Loop Antenna	30Apr04	30Apr05
00201	Empire	LC-105	Small Loop Antenna	30Apr04	30Apr05
00050	Chase	CBL-6111A	Bilog Antenna	30Apr04	30Apr05
00035	ETS	3115	Double Ridged Guide Horn	24Mar04	24Mar05
00202	ETS	3160-09	Small Horn Antenna	27May04	27Jun05
00015	Agilent	E4408B	Spectrum Analyzer	29Dec03	29Dec04
00049	HP	8566B	Spectrum Analyzer RF Section	18May04	18May05
00049	HP	85650A	Quasi-peak Adapter	18May04	18May05
00047	HP	85685A	RF Preselector	18May04	18May05
00048	Gore	65474	Microwave Cable	20May04	20May05
00030	HP	83017A	LNA	20May04	20May05

<b>Test Report S/N:</b>	052604-515/516KBC
<b>Test Date(s):</b>	28Jun04 - 29Jul04
<b>Test Type:</b>	FCC Part 15.247

**F.5. MEASUREMENT EQUIPMENT SETUP**

<b>MEASUREMENT EQUIPMENT CONNECTIONS</b>	The measurement equipment was connected as shown in F.6. A number of antennas were used to cover the applicable frequency range test. The ranges in which each antenna was used are as follows:			
	Frequency Range		Antenna	
	9 kHz – 150 kHz		LP-105 Loop	
	150 kHz – 30 MHz		LG-105 Loop	
	30 MHz – 1 GHz		CBL-6111A Bilog	
	1 GHz – 18 GHz		ETS 3115 Horn	
<b>MEASUREMENT EQUIPMENT SETTINGS</b>	18 GHz– 26GHz			
	The spectrum analyzer was set to the following settings:			
	Frequency Range	RBW	VBW	Detector
	MHz	kHz	kHz	
	0.009 - 0.150	0.200	10	Peak*
	0.150 - 30	9	30	Peak*
	30 – 1000	100	300	Peak*
> 1000	1000*	1000	Peak*	
*As a worse case measurement, the average/quasi-peak limits were applied to measurements made with a peak detector.				

**F.6. SETUP DRAWING**

Figure F-1 – Setup Drawing

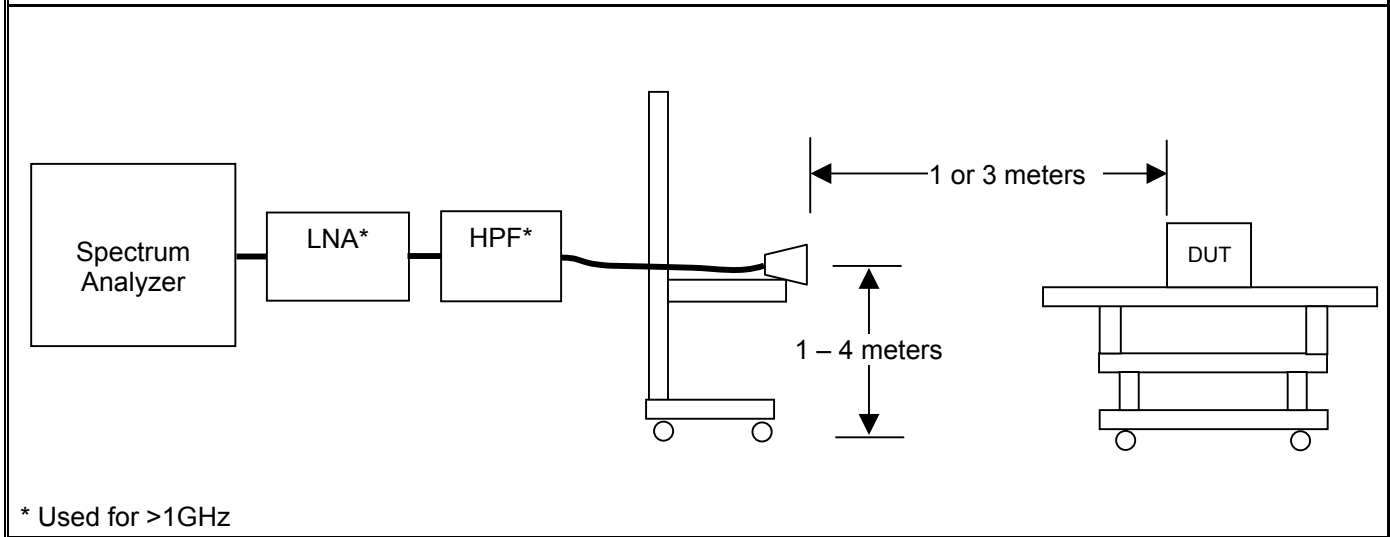

Test Report S/N:	052604-515/516KBC
Test Date(s):	28Jun04 - 29Jul04
Test Type:	FCC Part 15.247

### F.7. SETUP PHOTOGRAPHS

Photograph F-1 - Horizontal Polarization (30MHz – 1 GHz)

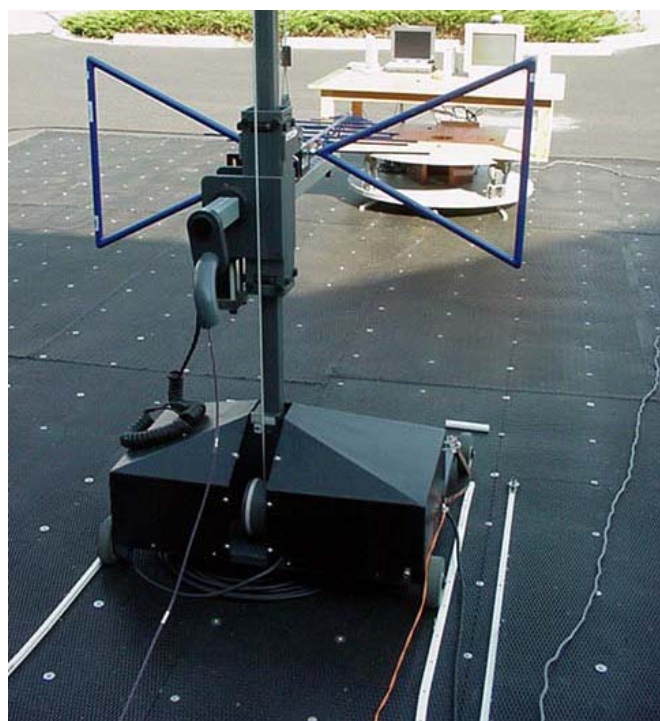

Photograph F-2 - Vertical Polarization (30MHz – 1 GHz)



Photograph F-3 - Front of Radiated Emission Configuration



Photograph F-4 - Back of Radiated Emission Configuration

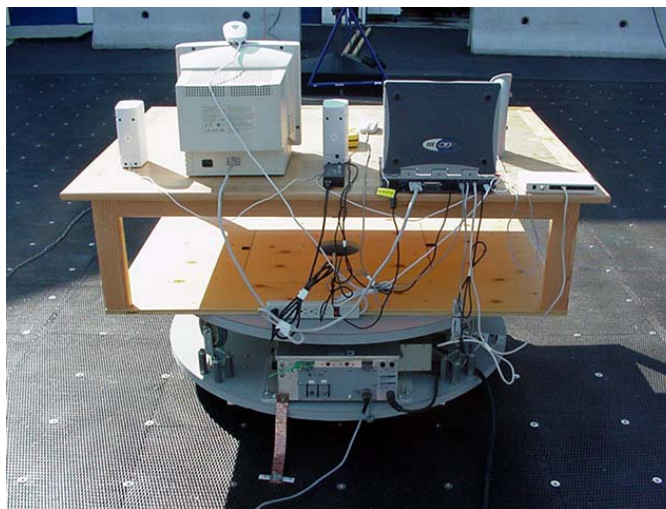

Itronix Corporation	FCC ID:	KBCIX260PRO2200	Model:	IX260+ with Intel Pro 2200BG WLAN
2004 Celltech Labs Inc	Rugged Laptop PC with internal WLAN Mini-PCI Card (802.11b/g)			56 of 84
This document is not to be reproduced in whole or in part without the written permission of Celltech Labs Inc.				



<b>Test Report S/N:</b>	052604-515/516KBC
<b>Test Date(s):</b>	28Jun04 - 29Jul04
<b>Test Type:</b>	FCC Part 15.247

### F.8. DUT OPERATING DESCRIPTION

The worst-case data rate was determined from prescan investigations. Measurements were made at three channels throughout the band, Low Channel (2412 MHz), Mid Channel (2437 MHz), High Channel (2462 MHz) and for both Modes b and g for the band-edge measurements and for Mode b for the remaining measurements.

### F.9. TEST RESULTS

#### F.9.1. Mode b - Band-edge Emission Field Strengths @ Specified Distance – Horizontal Polarization (near restricted band)

Channel	Polarity	Measurement Distance	Antenna	Frequency	SA Level	Noise Floor	Antenna Factor	Cable Factor	Other Factors	Total CF	Field Strength	Detector	Limit Distance	Limit Distance Correction	Limit	Margin	Pass/Fail
1	H	3	Horn SN6276	2390.00	28.40		28.06	3.47	0.00	31.53	59.93	PK	3.00	0.00	73.98	14.05	PASS
1	H	3	Horn SN6276	2390.00	17.00		28.06	3.47	0.00	31.53	48.53	AV	3.00	0.00	53.98	5.45	PASS
11	H	3	Horn SN6276	2483.50	27.20		28.26	3.51	0.00	31.78	58.98	PK	3.00	0.00	73.98	15.00	PASS
11	H	3	Horn SN6276	2483.50	17.30		28.26	3.51	0.00	31.78	49.08	AV	3.00	0.00	53.98	4.90	PASS

#### F.9.2. Mode b - Band-edge Emission Field Strengths @ Specified Distance - Vertical Polarization (near restricted band)

1	V	3	Horn SN6276	2390.00	28.40		28.06	3.47	0.00	31.53	59.93	PK	3.00	0.00	73.98	14.05	PASS
1	V	3	Horn SN6276	2390.00	17.00		28.06	3.47	0.00	31.53	48.53	AV	3.00	0.00	53.98	5.45	PASS
11	V	3	Horn SN6276	2483.50	26.50		28.26	3.51	0.00	31.78	58.28	PK	3.00	0.00	73.98	15.70	PASS
11	V	3	Horn SN6276	2483.50	16.80		28.26	3.51	0.00	31.78	48.58	AV	3.00	0.00	53.98	5.40	PASS

**Formulae:**

Total CF = Antenna Factor + Cable Factor + Other Factor (Amplifier Gain, filter loss, etc)

Field Strength = SA Reading + Total CF

Limit Distance Correction =  $40 \cdot \log(d1/d2)$  for  $F < 30$  MHz,  $20 \cdot \log(d1/d2)$  for  $F > 30$  MHz:

where d1 is the measurement distance, d2 is the published limit distance

Limit = Specified Limit + Limit Distance Correction

Margin = Limit - Field Strength

<b>Test Report S/N:</b>	052604-515/516KBC
<b>Test Date(s):</b>	28Jun04 - 29Jul04
<b>Test Type:</b>	FCC Part 15.247

F.9.3. Mode g - Band-edge Emission Field Strengths @ Specified Distance – Horizontal Polarization (near restricted band)

Channel	Polarity	Measurement Distance	Antenna	Frequency	SA Level	Noise Floor	Antenna Factor	Cable Factor	Other Factors	Total CF	Field Strength	Detector	Limit Distance	Limit Distance Correction	Limit	Margin	Pass/Fail
													m	dB	dBuV/m	Δ dB	
1	H	3	Horn SN6276	2390.00	31.20		28.06	3.47	0.00	31.53	62.73	PK	3.00	0.00	73.98	11.25	PASS
1	H	3	Horn SN6276	2390.00	18.90		28.06	3.47	0.00	31.53	50.43	AV	3.00	0.00	53.98	3.55	PASS
11	H	3	Horn SN6276	2483.50	35.20		28.26	3.51	0.00	31.78	66.98	PK	3.00	0.00	73.98	7.00	PASS
11	H	3	Horn SN6276	2483.50	20.90		28.26	3.51	0.00	31.78	52.68	AV	3.00	0.00	53.98	1.30	PASS

F.9.4. Mode g - Band-edge Emission Field Strengths @ Specified Distance - Vertical Polarization (near restricted band)

1	V	3	Horn SN6276	2390.00	28.10		28.06	3.47	0.00	31.53	59.63	PK	3.00	0.00	73.98	14.35	PASS
1	V	3	Horn SN6276	2390.00	17.40		28.06	3.47	0.00	31.53	48.93	AV	3.00	0.00	53.98	5.05	PASS
11	V	3	Horn SN6276	2483.50	31.10		28.26	3.51	0.00	31.78	62.88	PK	3.00	0.00	73.98	11.10	PASS
11	V	3	Horn SN6276	2483.50	18.30		28.26	3.51	0.00	31.78	50.08	AV	3.00	0.00	53.98	3.90	PASS

Formulae:

Total CF = Antenna Factor + Cable Factor + Other Factor (Amplifier Gain, filter loss, etc)

Field Strength = SA Reading + Total CF

Limit Distance Correction =  $40 \cdot \log(d1/d2)$  for  $F < 30$  MHz,  $20 \cdot \log(d1/d2)$  for  $F > 30$  MHz:

where d1 is the measurement distance, d2 is the published limit distance

Limit = Specified Limit + Limit Distance Correction

Margin = Limit - Field Strength

<b>Test Report S/N:</b>	052604-515/516KBC
<b>Test Date(s):</b>	28Jun04 - 29Jul04
<b>Test Type:</b>	FCC Part 15.247

F.9.5. Channel 1 Restricted Band Spurious Emission Field Strengths @ Specified Distance – Horizontal Polarization

Channel	Polarity	Measurement Distance	Antenna	Frequency	SA Level	Noise Floor	Antenna Factor	Cable Factor	Other Factors	Total CF	Field Strength	Detector	Limit Distance	Limit Distance Correction	15.209 (a) Limit	Margin	Pass/Fail
							dB/m	dB	dB	dB/m	dBuV/m		m	dB	dBuV/m		
1	H	3	Bilog SN1607	57.48	49.20		5.53	0.53	0.00	6.06	55.26	PK	3.00	0.00	60.00	4.74	PASS
1	H	3	Bilog SN1607	99.52	35.20		9.90	0.84	0.00	10.75	45.95	PK	3.00	0.00	63.52	17.57	PASS
1	H	3	Bilog SN1607	107.28	36.80		10.65	0.89	0.00	11.55	48.35	PK	3.00	0.00	63.52	15.17	PASS
1	H	3	Bilog SN1607	167.09	32.00		9.40	0.98	0.00	10.39	42.39	PK	3.00	0.00	63.52	21.14	PASS
1	H	3	Bilog SN1607	208.48	27.30		8.25	1.04	0.00	9.29	36.59	PK	3.00	0.00	63.52	26.93	PASS
1	H	3	Bilog SN1607	245.34	30.00		11.79	1.10	0.00	12.89	42.89	PK	3.00	0.00	66.02	23.14	PASS
1	H	3	Bilog SN1607	380.82	35.30		15.43	1.30	0.00	16.73	52.03	PK	3.00	0.00	66.02	13.99	PASS
1	H	3	Bilog SN1607	787.89	20.30		22.46	1.90	0.00	24.36	44.66	PK	3.00	0.00	66.02	21.36	PASS
1	H	3	Bilog SN1607	855.15	31.30		23.55	1.99	0.00	25.54	56.84	PK	3.00	0.00	66.02	9.18	PASS
1	H	3	Bilog SN1607	931.78	36.00		24.89	2.11	0.00	27.00	63.00	PK	3.00	0.00	66.02	3.02	PASS
1	H	3	Horn SN6276	2500.00	42.60		28.30	3.51	-36.42	-4.61	37.99	PK	3.00	0.00	73.98	35.99	PASS
1	H	3	Horn SN6276	4810.00	22.60	x	32.88	4.96	0.00	37.85	60.45	PK	3.00	0.00	73.98	13.53	PASS
1	H	3	Horn SN6276	5240.00	23.30	x	33.68	5.22	0.00	38.91	62.21	PK	3.00	0.00	73.98	11.77	PASS
1	H	3	Horn SN6276	7230.00	38.90	x	35.71	6.27	-35.51	6.47	45.37	PK	3.00	0.00	73.98	28.61	PASS
1	H	3	Horn SN6276	9610.00	37.10		37.59	7.37	-35.71	9.25	46.35	PK	3.00	0.00	73.98	27.63	PASS
1	H	3	Horn SN6276	17660.00	38.00	x	44.88	10.46	-36.36	18.98	56.98	PK	3.00	0.00	73.98	17.00	PASS
1	H	1	3160-09	19296.00	52.98		40.26	11.01	-35.81	15.45	68.43	PK	3.00	9.54	83.52	15.09	PASS
1	H	1	3160-09	19296.00	34.05		40.26	11.01	-35.81	15.45	49.50	AV	3.00	9.54	63.52	14.02	PASS
1	H	1	3160-09	21708.00	53.65		40.30	11.91	-35.73	16.48	70.13	PK	3.00	9.54	83.52	13.39	PASS
1	H	1	3160-09	21708.00	35.74		40.30	11.91	-35.73	16.48	52.22	AV	3.00	9.54	63.52	11.30	PASS
1	H	1	3160-09	24120.00	56.09		40.40	12.81	-35.73	17.48	73.57	PK	3.00	9.54	83.52	9.95	PASS
1	H	1	3160-09	24120.00	37.57		40.40	12.81	-35.73	17.48	55.05	AV	3.00	9.54	63.52	8.47	PASS
1	H	1	3160-09	24490.00	57.15		40.40	12.95	-35.73	17.62	74.77	PK	3.00	9.54	83.52	8.75	PASS
1	H	1	3160-09	24490.00	38.00		40.40	12.95	-35.73	17.62	55.62	AV	3.00	9.54	63.52	7.90	PASS

Formulae:

Total CF = Antenna Factor + Cable Factor + Other Factor (Amplifier Gain, filter loss, etc)

Field Strength = SA Reading + Total CF

Limit Distance Correction = 40\*log(d1/d2) for F<30 MHz, 20\*log(d1/d2) for F> 30 MHz:

where d1 is the measurement distance, d2 is the published limit distance

Limit = Specified Limit + Limit Distance Correction

Margin = Limit - Field Strength

\*No emissions within the restricted bands where measured above the levels noted

<b>Test Report S/N:</b>	052604-515/516KBC
<b>Test Date(s):</b>	28Jun04 - 29Jul04
<b>Test Type:</b>	FCC Part 15.247

F.9.6. Channel 1 Restricted Band Spurious Emission Field Strengths @ Specified Distance – Vertical Polarization

Channel	Polarity	Measurement Distance	Antenna	Frequency	SA Level	Noise Floor	Antenna Factor	Cable Factor	Other Factors	Total CF	Field Strength	Detector	Limit Distance	Limit Distance Correction	15.209 (a) Limit	Margin	Pass/Fail
													m	dB	dBuV/m	Δ dB	
1	V	3	LP-105	0.08	17.37		48.70	0.03	0.00	48.73	66.10	PK	300.00	80.00	143.54	77.44	PASS
1	V	3	LG-105	0.20	1.41		59.86	0.07	0.00	59.94	61.35	PK	300.00	80.00	134.52	73.17	PASS
1	V	3	LG-105	0.49	2.42		58.03	0.09	0.00	58.12	60.54	PK	300.00	80.00	114.16	53.62	PASS
1	V	3	LG-105	1.50	9.04		53.10	0.15	0.00	53.25	62.29	PK	30.00	40.00	84.80	22.51	PASS
1	V	3	LG-105	2.62	7.21		50.69	0.20	0.00	50.89	58.10	PK	30.00	40.00	89.54	31.44	PASS
1	V	3	LG-105	5.48	11.74		44.38	0.31	0.00	44.68	56.42	PK	30.00	40.00	89.54	33.12	PASS
1	V	3	LG-105	27.15	10.24		40.62	0.68	0.00	41.30	51.54	PK	30.00	40.00	89.54	38.00	PASS
1	V	3	Bilog SN1607	99.52	29.60		9.90	0.84	0.00	10.75	40.35	PK	3.00	0.00	63.52	23.17	PASS
1	V	3	Bilog SN1607	208.80	46.80		8.28	1.04	0.00	9.32	56.12	PK	3.00	0.00	63.52	7.40	PASS
1	V	3	Bilog SN1607	245.34	52.50		11.79	1.10	0.00	12.89	65.39	PK	3.00	0.00	66.02	0.64	PASS
1	V	3	Bilog SN1607	449.36	44.80		17.03	1.40	0.00	18.43	63.23	PK	3.00	0.00	66.02	2.79	PASS
1	V	3	Bilog SN1607	736.16	23.70		22.93	1.82	0.00	24.75	48.45	PK	3.00	0.00	66.02	17.57	PASS
1	V	3	Horn SN6276	3200.00	43.50		30.48	4.04	-35.93	-1.40	42.10	PK	3.00	0.00	73.98	31.88	PASS
1	V	3	Horn SN6276	4810.00	47.00		32.88	4.96	-35.30	2.54	49.54	PK	3.00	0.00	73.98	24.44	PASS
1	V	3	Horn SN6276	5260.00	40.10		33.72	5.23	-35.34	3.61	43.71	PK	3.00	0.00	73.98	30.27	PASS
1	V	3	Horn SN6276	5720.00	41.60		34.19	5.44	-35.38	4.25	45.85	PK	3.00	0.00	73.98	28.13	PASS
1	V	3	Horn SN6276	5770.00	44.80		34.21	5.45	-35.38	4.28	49.08	PK	3.00	0.00	73.98	24.90	PASS
1	V	3	Horn SN6276	7520.00	40.40		36.32	6.43	-35.53	7.21	47.61	PK	3.00	0.00	73.98	26.37	PASS
1	V	3	Horn SN6276	8360.00	37.60		37.06	6.79	-35.60	8.25	45.85	PK	3.00	0.00	73.98	28.13	PASS
1	V	3	Horn SN6276	9610.00	36.60		37.59	7.37	-35.71	9.25	45.85	PK	3.00	0.00	73.98	28.13	PASS
1	V	3	Horn SN6276	12640.00	36.90		38.71	8.68	-36.79	10.59	47.49	PK	3.00	0.00	73.98	26.49	PASS
1	V	3	Horn SN6276	15740.00	38.20		37.56	9.77	-36.53	10.80	49.00	PK	3.00	0.00	73.98	24.98	PASS
1	V	3	Horn SN6276	17770.00	37.60		45.70	10.30	-36.35	19.65	57.25	PK	3.00	0.00	73.98	16.73	PASS

Formulae:

Total CF = Antenna Factor + Cable Factor + Other Factor (Amplifier Gain, filter loss, etc)

Field Strength = SA Reading + Total CF

Limit Distance Correction =  $40 \cdot \log(d1/d2)$  for  $F < 30$  MHz,  $20 \cdot \log(d1/d2)$  for  $F > 30$  MHz:

where d1 is the measurement distance, d2 is the published limit distance

Limit = Specified Limit + Limit Distance Correction

Margin = Limit - Field Strength

\*No emissions within the restricted bands where measured above the levels noted

Continued

<b>Test Report S/N:</b>	052604-515/516KBC
<b>Test Date(s):</b>	28Jun04 - 29Jul04
<b>Test Type:</b>	FCC Part 15.247

Continued

Channel	Polarity	Measurement Distance	Antenna	Frequency	SA Level	Noise Floor	Antenna Factor	Cable Factor	Other Factors	Total CF	Field Strength	Detector	Limit Distance	Limit Distance Correction	15.209 (a) Limit	Margin	Pass/Fail
													m	dB	dBuV/m		
1	V	1	3160-09	18820.00	53.92		40.20	11.05	-35.87	15.38	69.30	PK	3.00	9.54	83.52	14.22	PASS
1	V	1	3160-09	18820.00	33.66		40.20	11.05	-35.87	15.38	49.04	AV	3.00	9.54	63.52	14.48	PASS
1	V	1	3160-09	19296.00	52.65		40.26	11.01	-35.81	15.45	68.10	PK	3.00	9.54	83.52	15.42	PASS
1	V	1	3160-09	19296.00	33.76		40.26	11.01	-35.81	15.45	49.21	AV	3.00	9.54	63.52	14.31	PASS
1	V	1	3160-09	21708.00	53.27		40.30	11.91	-35.73	16.48	69.75	PK	3.00	9.54	83.52	13.77	PASS
1	V	1	3160-09	21708.00	36.04		40.30	11.91	-35.73	16.48	52.52	AV	3.00	9.54	63.52	11.00	PASS
1	V	1	3160-09	24120.00	56.03		40.40	12.81	-35.73	17.48	73.51	PK	3.00	9.54	83.52	10.01	PASS
1	V	1	3160-09	24120.00	37.21		40.40	12.81	-35.73	17.48	54.69	AV	3.00	9.54	63.52	8.83	PASS
1	V	1	3160-09	24550.00	56.31		40.40	12.97	-35.73	17.64	73.95	PK	3.00	9.54	83.52	9.57	PASS
1	V	1	3160-09	24550.00	38.30		40.40	12.97	-35.73	17.64	55.94	AV	3.00	9.54	63.52	7.58	PASS

**Formulae:**

Total CF = Antenna Factor + Cable Factor + Other Factor (Amplifier Gain, filter loss, etc)

Field Strength = SA Reading + Total CF

Limit Distance Correction =  $40 \cdot \log(d1/d2)$  for  $F < 30$  MHz,  $20 \cdot \log(d1/d2)$  for  $F > 30$  MHz:

where d1 is the measurement distance, d2 is the published limit distance

Limit = Specified Limit + Limit Distance Correction

Margin = Limit - Field Strength

\*No emissions within the restricted bands where measured above the levels noted

<b>Test Report S/N:</b>	052604-515/516KBC
<b>Test Date(s):</b>	28Jun04 - 29Jul04
<b>Test Type:</b>	FCC Part 15.247

F.9.7. Channel 6 Restricted Band Spurious Emission Field Strengths @ Specified Distance – Horizontal Polarization

Channel	Polarity	Measurement Distance	Antenna	Frequency	SA Level	Noise Floor	Antenna Factor	Cable Factor	Other Factors	Total CF	Field Strength	Detector	Limit Distance	Limit Distance Correction	15.209 (a) Limit	Margin	Pass/Fail
6	H	3	Bilog SN1607	60.70	29.20		5.03	0.56	0.00	5.59	34.79	PK	3.00	0.00	60.00	25.21	PASS
6	H	3	Bilog SN1607	107.28	36.50		10.65	0.89	0.00	11.55	48.05	PK	3.00	0.00	63.52	15.47	PASS
6	H	3	Bilog SN1607	149.96	34.10		10.70	0.96	0.00	11.66	45.76	PK	3.00	0.00	63.52	17.76	PASS
6	H	3	Bilog SN1607	208.48	29.70		8.25	1.04	0.00	9.29	38.99	PK	3.00	0.00	63.52	24.53	PASS
6	H	3	Bilog SN1607	245.34	34.80		11.79	1.10	0.00	12.89	47.69	PK	3.00	0.00	66.02	18.34	PASS
6	H	3	Bilog SN1607	786.92	24.50		22.47	1.89	0.00	24.36	48.86	PK	3.00	0.00	66.02	17.16	PASS
6	H	3	Bilog SN1607	929.51	19.50		24.83	2.10	0.00	26.94	46.44	PK	3.00	0.00	66.02	19.58	PASS
6	H	3	Horn SN6276	2750.00	38.60		29.15	3.69	-36.38	-3.53	35.07	PK	3.00	0.00	73.98	38.91	PASS
6	H	3	Horn SN6276	3240.00	37.00		30.58	4.06	-36.12	-1.48	35.52	PK	3.00	0.00	73.98	38.46	PASS
6	H	3	Horn SN6276	4860.00	36.70		32.99	5.02	-35.46	2.55	39.25	PK	3.00	0.00	73.98	34.73	PASS
6	H	3	Horn SN6276	5260.00	45.20		33.72	5.23	-35.47	3.47	48.67	PK	3.00	0.00	73.98	25.31	PASS
6	H	3	Horn SN6276	5770.00	37.20		34.21	5.45	-35.50	4.16	41.36	PK	3.00	0.00	73.98	32.61	PASS
6	H	3	Horn SN6276	8280.00	38.40		36.98	6.75	-35.61	8.11	46.51	PK	3.00	0.00	73.98	27.47	PASS
6	H	3	Horn SN6276	8360.00	42.30		37.06	6.79	-35.62	8.24	50.54	PK	3.00	0.00	73.98	23.44	PASS
6	H	3	Horn SN6276	17090.00	39.20		41.24	10.38	-36.09	15.54	54.74	PK	3.00	0.00	73.98	19.24	PASS
6	H	1	3160-09	19496.00	52.56		40.30	11.28	-35.79	15.79	68.35	PK	3.00	9.54	83.52	15.17	PASS
6	H	1	3160-09	19496.00	33.91		40.30	11.28	-35.79	15.79	49.70	AV	3.00	9.54	63.52	13.82	PASS
6	H	1	3160-09	21240.00	54.98		40.30	11.73	-35.73	16.31	71.29	PK	3.00	9.54	83.52	12.23	PASS
6	H	1	3160-09	21240.00	35.72		40.30	11.73	-35.73	16.31	52.03	AV	3.00	9.54	63.52	11.49	PASS
6	H	1	3160-09	21933.00	54.66		40.30	11.99	-35.73	16.57	71.23	PK	3.00	9.54	83.52	12.30	PASS
6	H	1	3160-09	21933.00	36.27		40.30	11.99	-35.73	16.57	52.84	AV	3.00	9.54	63.52	10.69	PASS
6	H	1	3160-09	24370.00	57.10		40.40	12.90	-35.73	17.58	74.68	PK	3.00	9.54	83.52	8.84	PASS
6	H	1	3160-09	24370.00	37.88		40.40	12.90	-35.73	17.58	55.46	AV	3.00	9.54	63.52	8.06	PASS
6	H	1	3160-09	24420.00	56.93		40.40	12.92	-35.73	17.60	74.53	PK	3.00	9.54	83.52	9.00	PASS
6	H	1	3160-09	24420.00	37.73		40.40	12.92	-35.73	17.60	55.33	AV	3.00	9.54	63.52	8.20	PASS

Formulae:

Total CF = Antenna Factor + Cable Factor + Other Factor (Amplifier Gain, filter loss, etc)

Field Strength = SA Reading + Total CF

Limit Distance Correction = 40\*log(d1/d2) for F<30 MHz, 20\*log(d1/d2) for F> 30 MHz:

where d1 is the measurement distance, d2 is the published limit distance

Limit = Specified Limit + Limit Distance Correction

Margin = Limit - Field Strength

\*No emissions within the restricted bands where measured above the levels noted

<b>Test Report S/N:</b>	052604-515/516KBC
<b>Test Date(s):</b>	28Jun04 - 29Jul04
<b>Test Type:</b>	FCC Part 15.247

F.9.8. Channel 6 Restricted Band Spurious Emission Field Strengths @ Specified Distance – Vertical Polarization

Channel	Polarity	Measurement Distance	Antenna	Frequency	SA Level	Noise Floor	Antenna Factor	Cable Factor	Other Factors	Total CF	Field Strength	Detector	Limit Distance	Limit Distance Correction	15.209 (a) Limit	Margin	Pass/Fail
							dB/m	dB	dB	dB/m	dBuV/m		m	dB	dBuV/m		
6	V	3	LP-105	0.08	17.57		48.71	0.05	0.00	48.76	66.33	PK	300.00	80.00	143.55	77.22	PASS
6	V	3	LG-105	2.03	9.04		52.21	0.17	0.00	52.39	61.43	PK	30.00	40.00	89.54	28.11	PASS
6	V	3	LG-105	0.83	2.38		57.38	0.11	0.00	57.49	59.87	PK	30.00	40.00	90.77	30.90	PASS
6	V	3	LG-105	1.50	8.52		53.11	0.15	0.00	53.26	61.78	PK	30.00	40.00	84.82	23.04	PASS
6	V	3	LG-105	3.22	8.34		49.31	0.23	0.00	49.54	57.88	PK	30.00	40.00	89.54	31.66	PASS
6	V	3	LG-105	5.63	12.44		44.09	0.31	0.00	44.40	56.84	PK	30.00	40.00	89.54	32.70	PASS
6	V	3	LG-105	17.80	9.89		41.04	0.55	0.00	41.59	51.48	PK	30.00	40.00	89.54	38.06	PASS
6	V	3	Bilog SN1607	57.48	30.80		5.53	0.53	0.00	6.06	36.86	PK	3.00	0.00	60.00	23.14	PASS
6	V	3	Bilog SN1607	99.52	28.50		9.90	0.84	0.00	10.75	39.25	PK	3.00	0.00	63.52	24.27	PASS
6	V	3	Bilog SN1607	103.72	27.90		10.33	0.88	0.00	11.21	39.11	PK	3.00	0.00	63.52	24.41	PASS
6	V	3	Bilog SN1607	138.96	37.30		11.14	0.94	0.00	12.08	49.38	PK	3.00	0.00	63.52	14.14	PASS
6	V	3	Bilog SN1607	166.77	24.50		9.43	0.98	0.00	10.41	34.91	PK	3.00	0.00	63.52	28.61	PASS
6	V	3	Bilog SN1607	196.19	31.70		8.47	1.03	0.00	9.49	41.19	PK	3.00	0.00	63.52	22.33	PASS
6	V	3	Bilog SN1607	196.52	29.70		8.44	1.03	0.00	9.47	39.17	PK	3.00	0.00	63.52	24.35	PASS
6	V	3	Bilog SN1607	246.96	28.50		11.97	1.10	0.00	13.07	41.57	PK	3.00	0.00	66.02	24.46	PASS
6	V	3	Bilog SN1607	306.45	27.50		13.40	1.19	0.00	14.58	42.08	PK	3.00	0.00	66.02	23.94	PASS
6	V	3	Bilog SN1607	772.70	37.20		22.57	1.87	0.00	24.45	61.65	PK	3.00	0.00	66.02	4.37	PASS
6	V	3	Bilog SN1607	952.47	34.80		25.36	2.14	0.00	27.50	62.30	PK	3.00	0.00	66.02	3.72	PASS
6	V	3	Horn SN6276	2830.00	37.90		29.42	3.75	-36.33	-3.16	34.74	PK	3.00	0.00	73.98	39.24	PASS
6	V	3	Horn SN6276	5240.00	37.30		33.68	5.22	-35.47	3.43	40.73	PK	3.00	0.00	73.98	33.24	PASS
6	V	3	Horn SN6276	5770.00	40.10		34.21	5.45	-35.50	4.16	44.26	PK	3.00	0.00	73.98	29.71	PASS
6	V	3	Horn SN6276	7520.00	37.80		36.32	6.43	-35.58	7.17	44.97	PK	3.00	0.00	73.98	29.01	PASS

Formulae:

Total CF = Antenna Factor + Cable Factor + Other Factor (Amplifier Gain, filter loss, etc)

Field Strength = SA Reading + Total CF

Limit Distance Correction = 40\*log(d1/d2) for F<30 MHz, 20\*log(d1/d2) for F> 30 MHz:

where d1 is the measurement distance, d2 is the published limit distance

Limit = Specified Limit + Limit Distance Correction

Margin = Limit - Field Strength

\*No emissions within the restricted bands where measured above the levels noted

Continued

<b>Test Report S/N:</b>	052604-515/516KBC
<b>Test Date(s):</b>	28Jun04 - 29Jul04
<b>Test Type:</b>	FCC Part 15.247

Continued

Channel	Polarity	Measurement Distance	Antenna	Frequency	SA Level	Noise Floor	Antenna Factor	Cable Factor	Other Factors	Total CF	Field Strength	Detector	Limit Distance	Limit Distance Correction	15.209 (a) Limit	Margin	Pass/Fail
													m	dB	dBuV/m	Δ dB	
6	V	3	Horn SN6276	9720.00	36.80		37.68	7.34	-35.71	9.31	46.11	PK	3.00	0.00	73.98	27.87	PASS
6	V	3	Horn SN6276	16480.00	38.30		38.45	10.25	-36.16	12.54	50.84	PK	3.00	0.00	73.98	23.14	PASS
6	V	1	3160-09	19190.00	54.26		40.24	10.91	-35.83	15.32	69.58	PK	3.00	9.54	83.52	13.94	PASS
6	V	1	3160-09	19190.00	33.78		40.24	10.91	-35.83	15.32	49.10	AV	3.00	9.54	63.52	14.42	PASS
6	V	1	3160-09	19496.00	52.89		40.30	11.28	-35.79	15.79	68.68	PK	3.00	9.54	83.52	14.84	PASS
6	V	1	3160-09	19496.00	33.88		40.30	11.28	-35.79	15.79	49.67	AV	3.00	9.54	63.52	13.85	PASS
6	V	1	3160-09	21933.00	53.99		40.30	11.99	-35.73	16.57	70.56	PK	3.00	9.54	83.52	12.97	PASS
6	V	1	3160-09	21933.00	36.23		40.30	11.99	-35.73	16.57	52.80	AV	3.00	9.54	63.52	10.73	PASS
6	V	1	3160-09	24370.00	55.56		40.40	12.90	-35.73	17.58	73.14	PK	3.00	9.54	83.52	10.38	PASS
6	V	1	3160-09	24370.00	37.88		40.40	12.90	-35.73	17.58	55.46	AV	3.00	9.54	63.52	8.06	PASS
6	V	1	3160-09	24400.00	56.66		40.40	12.91	-35.73	17.59	74.25	PK	3.00	9.54	83.52	9.27	PASS
6	V	1	3160-09	24400.00	37.87		40.40	12.91	-35.73	17.59	55.46	AV	3.00	9.54	63.52	8.06	PASS

**Formulae:**

Total CF = Antenna Factor + Cable Factor + Other Factor (Amplifier Gain, filter loss, etc)

Field Strength = SA Reading + Total CF

Limit Distance Correction =  $40 \cdot \log(d1/d2)$  for  $F < 30$  MHz,  $20 \cdot \log(d1/d2)$  for  $F > 30$  MHz:

where d1 is the measurement distance, d2 is the published limit distance

Limit = Specified Limit + Limit Distance Correction

Margin = Limit - Field Strength

\*No emissions within the restricted bands where measured above the levels noted



<b>Test Report S/N:</b>	052604-515/516KBC
<b>Test Date(s):</b>	28Jun04 - 29Jul04
<b>Test Type:</b>	FCC Part 15.247

F.9.9. Channel 11 Restricted Band Spurious Emission Field Strengths @ Specified Distance – Horizontal Polarization

Channel	Polarity	Measurement Distance	Antenna	Frequency	SA Level	Noise Floor	Antenna Factor	Cable Factor	Other Factors	Total CF	Field Strength	Detector	Limit Distance	Limit Distance Correction	15.209 (a) Limit	Margin	Pass/Fail
11	H	3	Bilog SN1607	57.80	48.10		5.45	0.54	0.00	5.99	54.09	PK	3.00	0.00	60.00	5.91	PASS
11	H	3	Bilog SN1607	101.13	38.90		10.10	0.86	0.00	10.96	49.86	PK	3.00	0.00	63.52	13.66	PASS
11	H	3	Bilog SN1607	141.55	31.30		11.07	0.95	0.00	12.01	43.31	PK	3.00	0.00	63.52	20.21	PASS
11	H	3	Bilog SN1607	208.80	31.20		8.28	1.04	0.00	9.32	40.52	PK	3.00	0.00	63.52	23.00	PASS
11	H	3	Bilog SN1607	297.72	29.20		13.28	1.17	0.00	14.45	43.65	PK	3.00	0.00	66.02	22.37	PASS
11	H	3	Bilog SN1607	381.14	44.00		15.45	1.30	0.00	16.74	60.74	PK	3.00	0.00	66.02	5.28	PASS
11	H	3	Bilog SN1607	772.70	28.40		22.57	1.87	0.00	24.45	52.85	PK	3.00	0.00	66.02	13.17	PASS
11	H	3	Bilog SN1607	944.39	31.30		25.21	2.13	0.00	27.34	58.64	PK	3.00	0.00	66.02	7.38	PASS
11	H	3	Horn SN6276	2810.00	37.50		29.35	3.74	-36.34	-3.25	34.25	PK	3.00	0.00	73.98	39.73	PASS
11	H	3	Horn SN6276	4900.00	39.50		33.08	5.05	-35.46	2.68	42.18	PK	3.00	0.00	73.98	31.80	PASS
11	H	3	Horn SN6276	5260.00	45.80		33.72	5.23	-35.47	3.47	49.27	PK	3.00	0.00	73.98	24.71	PASS
11	H	3	Horn SN6276	8280.00	39.30		36.98	6.75	-35.61	8.11	47.41	PK	3.00	0.00	73.98	26.57	PASS
11	H	3	Horn SN6276	8360.00	42.10		37.06	6.79	-35.62	8.24	50.34	PK	3.00	0.00	73.98	23.64	PASS
11	H	3	Horn SN6276	9820.00	39.00		37.76	7.44	-35.77	9.42	48.42	PK	3.00	0.00	73.98	25.56	PASS
11	H	3	Horn SN6276	15920.00	38.90		37.38	9.83	-36.23	10.98	49.88	PK	3.00	0.00	73.98	24.10	PASS
11	H	1	3160-09	18810.00	53.72		40.20	11.15	-35.87	15.48	69.20	PK	3.00	9.54	83.52	14.33	PASS
11	H	1	3160-09	18810.00	33.94		40.20	11.15	-35.87	15.48	49.42	AV	3.00	9.54	63.52	14.11	PASS
11	H	1	3160-09	19696.00	53.67		40.30	11.42	-35.76	15.95	69.62	PK	3.00	9.54	83.52	13.90	PASS
11	H	1	3160-09	19696.00	33.44		40.30	11.42	-35.76	15.95	49.39	AV	3.00	9.54	63.52	14.13	PASS
11	H	1	3160-09	22158.00	53.69		40.33	12.08	-35.73	16.68	70.37	PK	3.00	9.54	83.52	13.15	PASS
11	H	1	3160-09	22158.00	35.90		40.33	12.08	-35.73	16.68	52.58	AV	3.00	9.54	63.52	10.94	PASS
11	H	1	3160-09	24460.00	56.88		40.40	12.94	-35.73	17.61	74.49	PK	3.00	9.54	83.52	9.03	PASS
11	H	1	3160-09	24460.00	37.32		40.40	12.94	-35.73	17.61	54.93	AV	3.00	9.54	63.52	8.59	PASS
11	H	1	3160-09	24620.00	55.75		40.40	13.00	-35.73	17.67	73.42	PK	3.00	9.54	83.52	10.10	PASS
11	H	1	3160-09	24620.00	37.57		40.40	13.00	-35.73	17.67	55.24	AV	3.00	9.54	63.52	8.28	PASS

Formulae:

Total CF = Antenna Factor + Cable Factor + Other Factor (Amplifier Gain, filter loss, etc)

Field Strength = SA Reading + Total CF

Limit Distance Correction = 40\*log(d1/d2) for F<30 MHz, 20\*log(d1/d2) for F> 30 MHz:

where d1 is the measurement distance, d2 is the published limit distance

Limit = Specified Limit + Limit Distance Correction

Margin = Limit - Field Strength

\*No emissions within the restricted bands where measured above the levels noted

<b>Test Report S/N:</b>	052604-515/516KBC
<b>Test Date(s):</b>	28Jun04 - 29Jul04
<b>Test Type:</b>	FCC Part 15.247

F.9.10. Channel 11 Restricted Band Spurious Emission Field Strengths @ Specified Distance – Vertical Polarization

Channel	Polarity	Measurement Distance	Antenna	Frequency	SA Level	Noise Floor	Antenna Factor	Cable Factor	Other Factors	Total CF	Field Strength	Detector	Limit Distance	Limit Distance Correction	15.209 (a) Limit	Margin	Pass/Fail
							dB/m	dB	dB	dB/m	dBuV/m		m	dB	dBuV/m	Δ dB	
11	V	3	LP-105	0.08	19.50		48.79	0.04	0.00	48.83	68.33	PK	300.00	80.00	143.60	75.27	PASS
11	V	3	LG-105	0.20	1.04		59.88	0.07	0.00	59.95	60.99	PK	300.00	80.00	134.59	73.60	PASS
11	V	3	LG-105	0.79	1.46		57.46	0.12	0.00	57.57	59.03	PK	30.00	40.00	91.16	32.13	PASS
11	V	3	LG-105	1.44	8.37		53.25	0.15	0.00	53.40	61.77	PK	30.00	40.00	85.34	23.57	PASS
11	V	3	LG-105	4.05	10.60		47.10	0.26	0.00	47.36	57.96	PK	30.00	40.00	89.54	31.58	PASS
11	V	3	LG-105	5.26	10.77		44.79	0.30	0.00	45.09	55.86	PK	30.00	40.00	89.54	33.68	PASS
11	V	3	LG-105	13.95	9.95		40.60	0.50	0.00	41.09	51.04	PK	30.00	40.00	89.54	38.50	PASS
11	V	3	Bilog SN1607	138.96	37.30		11.14	0.94	0.00	12.08	49.38	PK	3.00	0.00	63.52	14.14	PASS
11	V	3	Bilog SN1607	164.83	39.20		9.57	0.98	0.00	10.54	49.74	PK	3.00	0.00	63.52	13.78	PASS
11	V	3	Bilog SN1607	208.48	44.90		8.25	1.04	0.00	9.29	54.19	PK	3.00	0.00	63.52	9.33	PASS
11	V	3	Bilog SN1607	245.02	44.80		11.75	1.10	0.00	12.85	57.65	PK	3.00	0.00	66.02	8.37	PASS
11	V	3	Bilog SN1607	794.04	35.60		22.51	1.90	0.00	24.42	60.02	PK	3.00	0.00	66.02	6.01	PASS
11	V	3	Horn SN6276	2810.00	37.20		29.35	3.74	-36.34	-3.25	33.95	PK	3.00	0.00	73.98	40.03	PASS
11	V	3	Horn SN6276	5270.00	36.40		33.73	5.24	-35.47	3.49	39.89	PK	3.00	0.00	73.98	34.09	PASS
11	V	3	Horn SN6276	5770.00	42.50		34.21	5.45	-35.50	4.16	46.66	PK	3.00	0.00	73.98	27.31	PASS
11	V	3	Horn SN6276	9820.00	36.60		37.76	7.44	-35.77	9.42	46.02	PK	3.00	0.00	73.98	27.96	PASS
11	V	3	Horn SN6276	16680.00	39.00		39.29	10.24	-36.14	13.40	52.40	PK	3.00	0.00	73.98	21.58	PASS
11	V	1	3160-09	19696.00	53.07		40.30	11.42	-35.76	15.95	69.02	PK	3.00	9.54	83.52	14.50	PASS
11	V	1	3160-09	19696.00	33.28		40.30	11.42	-35.76	15.95	49.23	AV	3.00	9.54	63.52	14.29	PASS
11	V	1	3160-09	20660.00	55.02		40.30	11.74	-35.73	16.31	71.33	PK	3.00	9.54	83.52	12.19	PASS
11	V	1	3160-09	20660.00	35.18		40.30	11.74	-35.73	16.31	51.49	AV	3.00	9.54	63.52	12.03	PASS

Formulae:

Total CF = Antenna Factor + Cable Factor + Other Factor (Amplifier Gain, filter loss, etc)

Field Strength = SA Reading + Total CF

Limit Distance Correction = 40\*log(d1/d2) for F<30 MHz, 20\*log(d1/d2) for F> 30 MHz:

where d1 is the measurement distance, d2 is the published limit distance

Limit = Specified Limit + Limit Distance Correction

Margin = Limit - Field Strength

\*No emissions within the restricted bands where measured above the levels noted

Continued

<b>Test Report S/N:</b>	052604-515/516KBC
<b>Test Date(s):</b>	28Jun04 - 29Jul04
<b>Test Type:</b>	FCC Part 15.247

Continued

Channel	Polarity	Measurement Distance	Antenna	Frequency	SA Level	Noise Floor	Antenna Factor	Cable Factor	Other Factors	Total CF	Field Strength	Detector	Limit Distance	Limit Distance Correction	15.209 (a) Limit	Margin	Pass/Fail
													m	dB	dBuV/m	Δ dB	
11	V	1	3160-09	22158.00	54.12		40.33	12.08	-35.73	16.68	70.80	PK	3.00	9.54	83.52	12.72	PASS
11	V	1	3160-09	22158.00	33.80		40.33	12.08	-35.73	16.68	50.48	AV	3.00	9.54	63.52	13.04	PASS
11	V	1	3160-09	23950.00	57.28		40.40	12.75	-35.73	17.42	74.70	PK	3.00	9.54	83.52	8.82	PASS
11	V	1	3160-09	23950.00	36.43		40.40	12.75	-35.73	17.42	53.85	AV	3.00	9.54	63.52	9.67	PASS
11	V	1	3160-09	24620.00	55.73		40.40	13.00	-35.73	17.67	73.40	PK	3.00	9.54	83.52	10.12	PASS
11	V	1	3160-09	24620.00	37.92		40.40	13.00	-35.73	17.67	55.59	AV	3.00	9.54	63.52	7.93	PASS

**Formulae:**

Total CF = Antenna Factor + Cable Factor + Other Factor (Amplifier Gain, filter loss, etc)

Field Strength = SA Reading + Total CF

Limit Distance Correction =  $40 \cdot \log(d1/d2)$  for  $F < 30$  MHz,  $20 \cdot \log(d1/d2)$  for  $F > 30$  MHz:  
 where d1 is the measurement distance, d2 is the published limit distance

Limit = Specified Limit + Limit Distance Correction

Margin = Limit - Field Strength

\*No emissions within the restricted bands where measured above the levels noted

**F.10. PASS/FAIL**

In reference to the results outlined in F.9, the DUT passes the requirements as stated in the reference standards as follows: FCC 15.205 (a) (b) and 15.209 (a): No emissions were measured within the restricted bands as outlined in 15.205 that exceeded the limits stated in 15.209.

**F.11. SIGN-OFF**

I attest to the accuracy of the data. All measurements reported herein were performed by me and are correct to the best of my knowledge and belief. I assume full responsibility for the completeness of these measurements.



Russell Pipe  
 Senior Compliance Technologist  
 Celltech Labs Inc.

29Jul04

Date

<b>Test Report S/N:</b>	052604-515/516KBC
<b>Test Date(s):</b>	28Jun04 - 29Jul04
<b>Test Type:</b>	FCC Part 15.247

### Appendix G - Peak Power Spectral Density Measurement

G.1. REFERENCES	
<b>Normative Reference Standard</b>	FCC CFR 47 §15.247(d)
<b>Procedure Reference</b>	FCC 97-114

G.2. LIMITS	
G.2.1. FCC CFR	
<p>§15.247(d): For digitally modulated systems, the peak power spectral density conducted from the intentional radiator to the antenna shall not be greater than +8 dBm in any 3 kHz band during any time interval of continuous transmission.</p>	

G.3. ENVIRONMENTAL CONDITIONS	
<b>Temperature</b>	25.2 +/- 2 °C
<b>Humidity</b>	35 +/- 2 %
<b>Barometric Pressure</b>	96.34 kPa

G.4. EQUIPMENT LIST					
ASSET NUMBER	MANUFACTURER	MODEL	DESCRIPTION	LAST CAL	CAL DUE
00015	Agilent	E4408B	Spectrum Analyzer	29Dec03	29Dec04
00075	Alpha Wire-J	9223	2ft. RG223/U RF Cable	08Jul04*	24Jun05
00076	Pasternack	PE7014-30	30dB 2 Watt Attenuator	08Jul04*	24Jun05

\*Cable and attenuator verified with power meter prior to use

G.5. MEASUREMENT EQUIPMENT SETUP	
<b>Measurement Equipment Connections</b>	The equipment was connected as shown in the setup drawing in G.6.
<b>Measurement Equipment Settings</b>	<p>The spectrum analyzer was configured with the following settings:</p> <p>RBW – 3 kHz          VBW – 10 kHz          Sweep time – 500 seconds          Span – 1.5 MHz</p>

<b>Test Report S/N:</b>	052604-515/516KBC
<b>Test Date(s):</b>	28Jun04 - 29Jul04
<b>Test Type:</b>	FCC Part 15.247

**G.6. SETUP DRAWING**

Figure G-1 – Setup Drawing

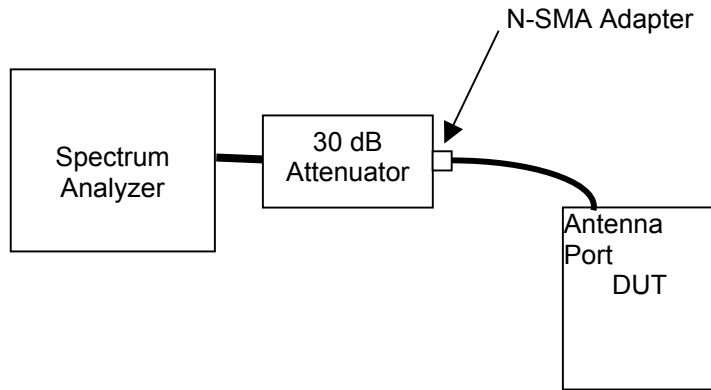

**G.7. DUT OPERATING DESCRIPTION**

The worst-case data rate was determined from prescan investigations. Measurements were made at three channels throughout the band, Low Channel (2412 MHz), Mid Channel (2437 MHz), High Channel (2462 MHz) and for both Modes b and g.

**G.8. TEST RESULTS**

Channel	802.11b			802.11g		
	Frequency (GHz)	PPSD (dBm)	Data Rate Mb/s	Frequency (GHz)	PPSD (dBm)	Data Rate Mb/s
Low	2.411340	-8.516	1	2.411374	-11.69	6
Mid	2.437589	-8.287	1	2.436670	-12.35	6
High	2.461261	-7.351	1	2.462623	-12.05	6

<b>Test Report S/N:</b>	052604-515/516KBC
<b>Test Date(s):</b>	28Jun04 - 29Jul04
<b>Test Type:</b>	FCC Part 15.247

Plot G-1 - PPSD Low Channel (802.11b)

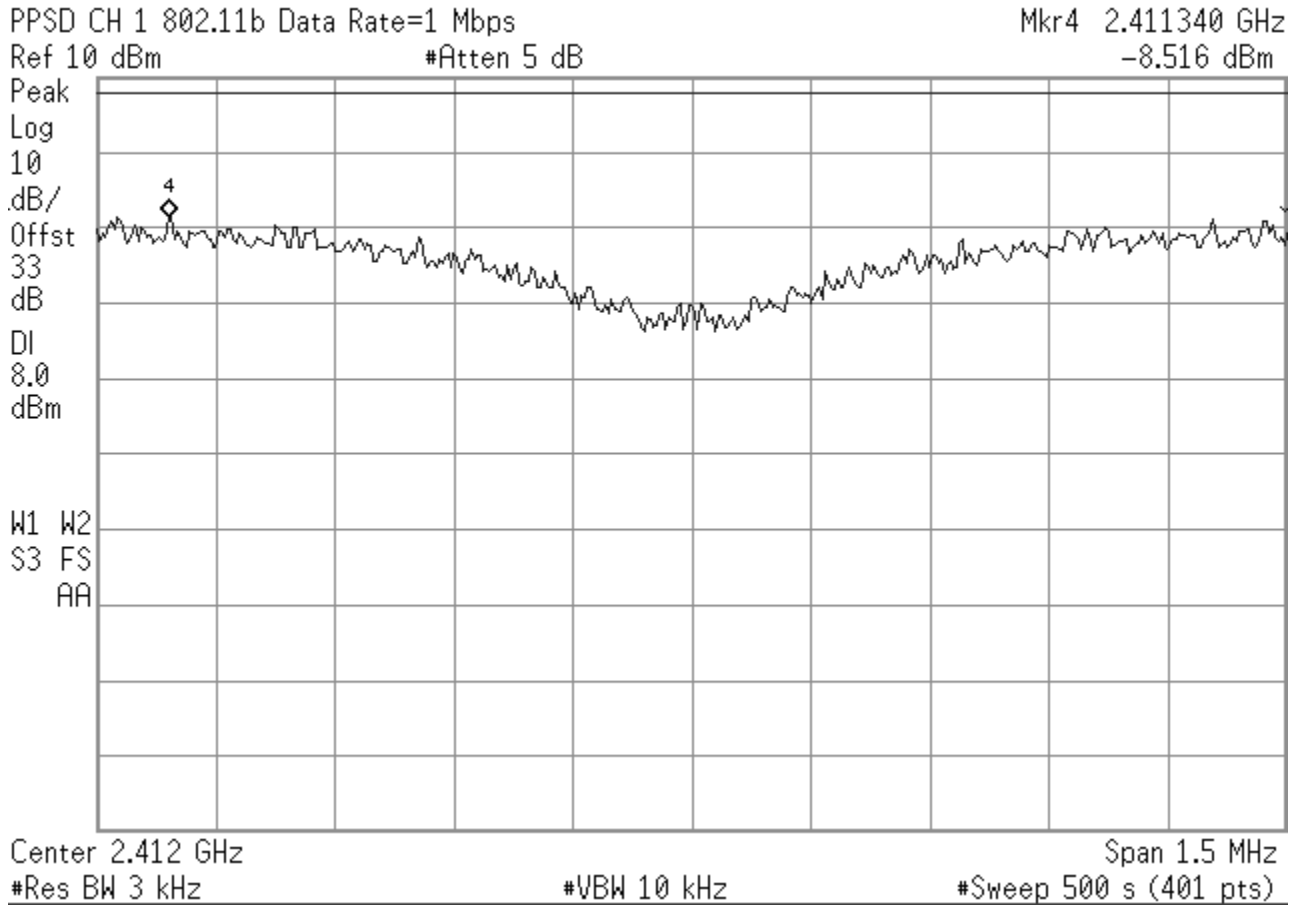

<b>Test Report S/N:</b>	052604-515/516KBC
<b>Test Date(s):</b>	28Jun04 - 29Jul04
<b>Test Type:</b>	FCC Part 15.247

Plot G-2 - PPSD Mid Channel (802.11b)

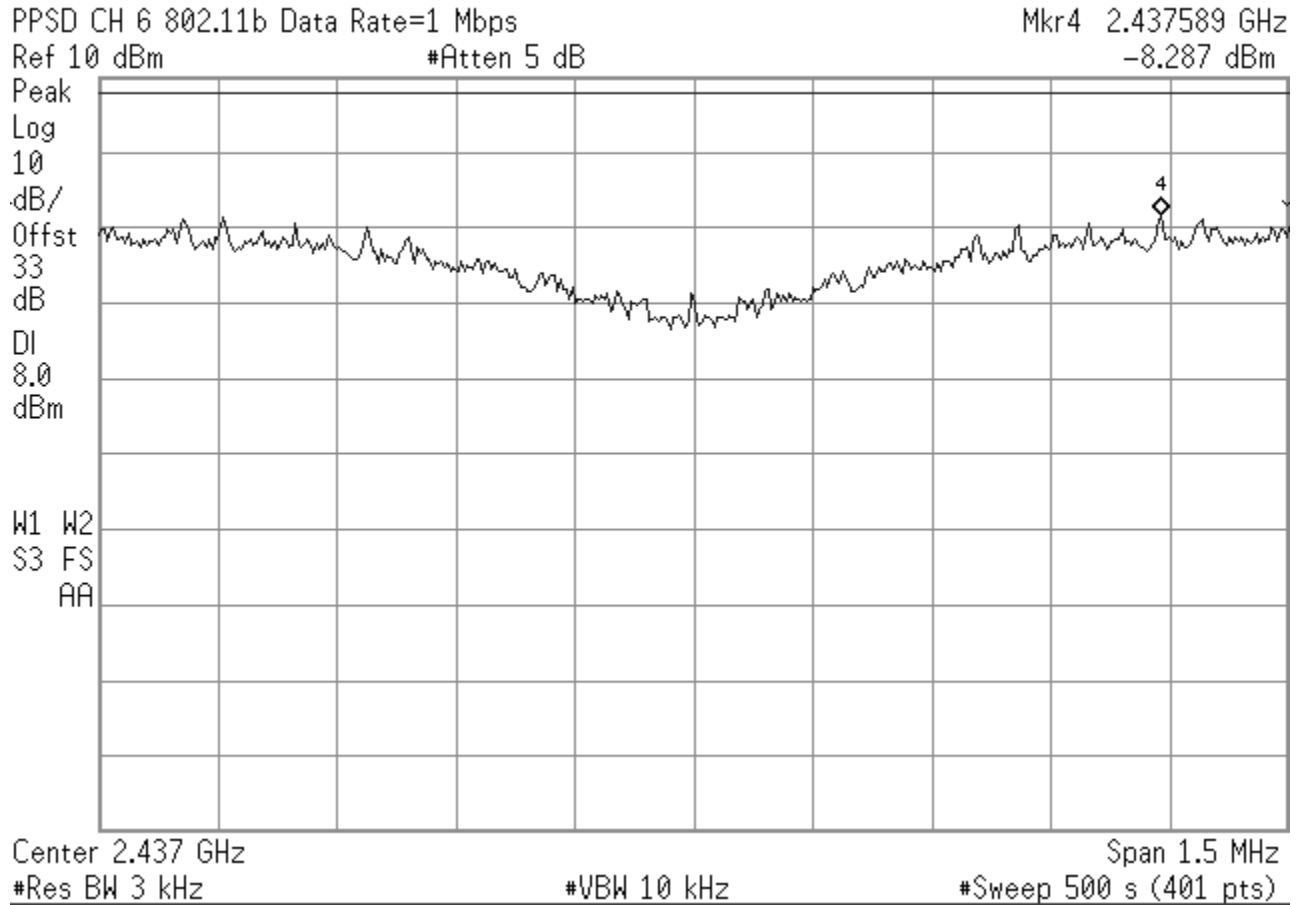

<b>Test Report S/N:</b>	052604-515/516KBC
<b>Test Date(s):</b>	28Jun04 - 29Jul04
<b>Test Type:</b>	FCC Part 15.247

Plot G-3 - PPSD High Channel (802.11b)

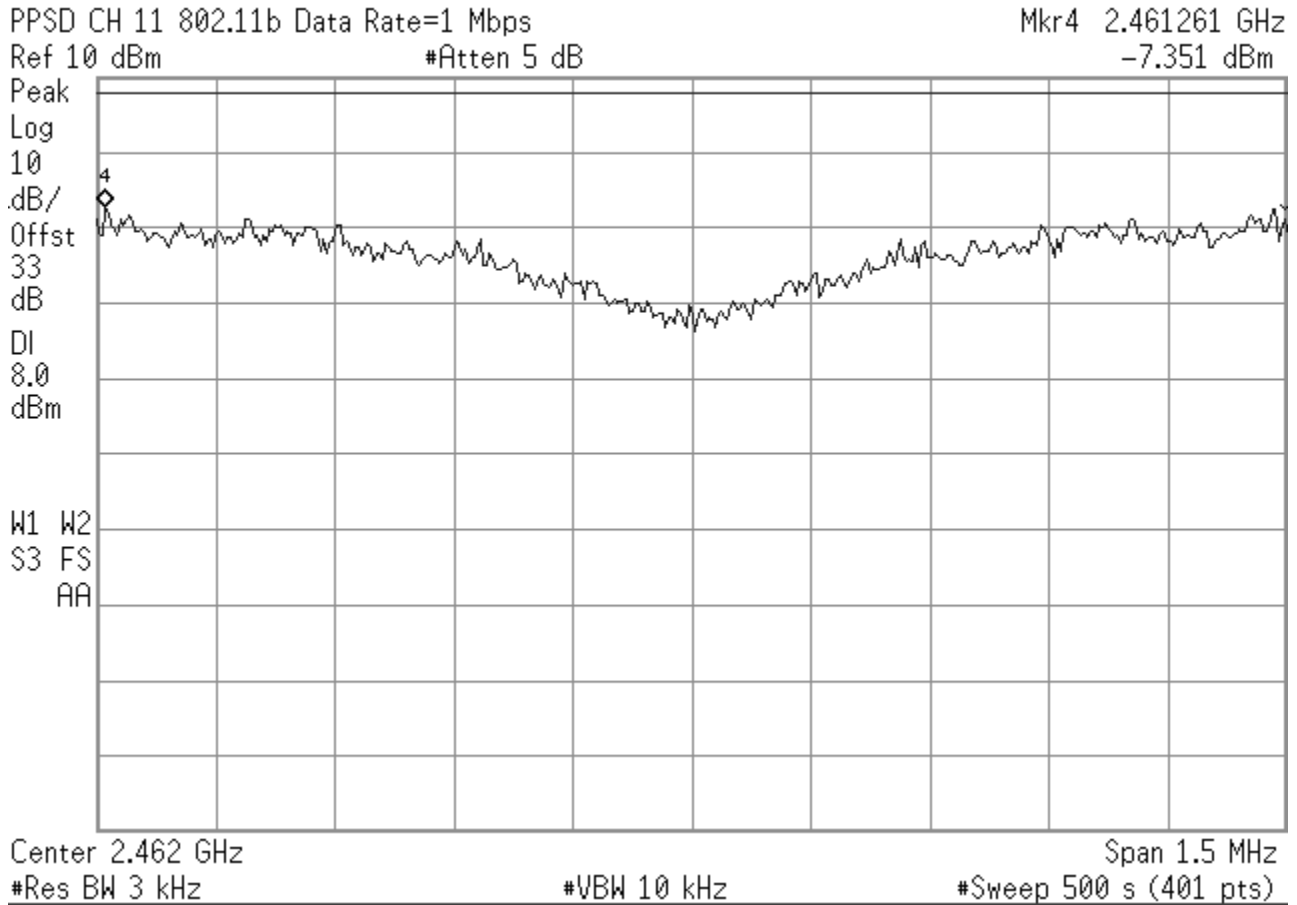



<b>Test Report S/N:</b>	052604-515/516KBC
<b>Test Date(s):</b>	28Jun04 - 29Jul04
<b>Test Type:</b>	FCC Part 15.247

Plot G-4 - PPSD Low Channel (802.11g)

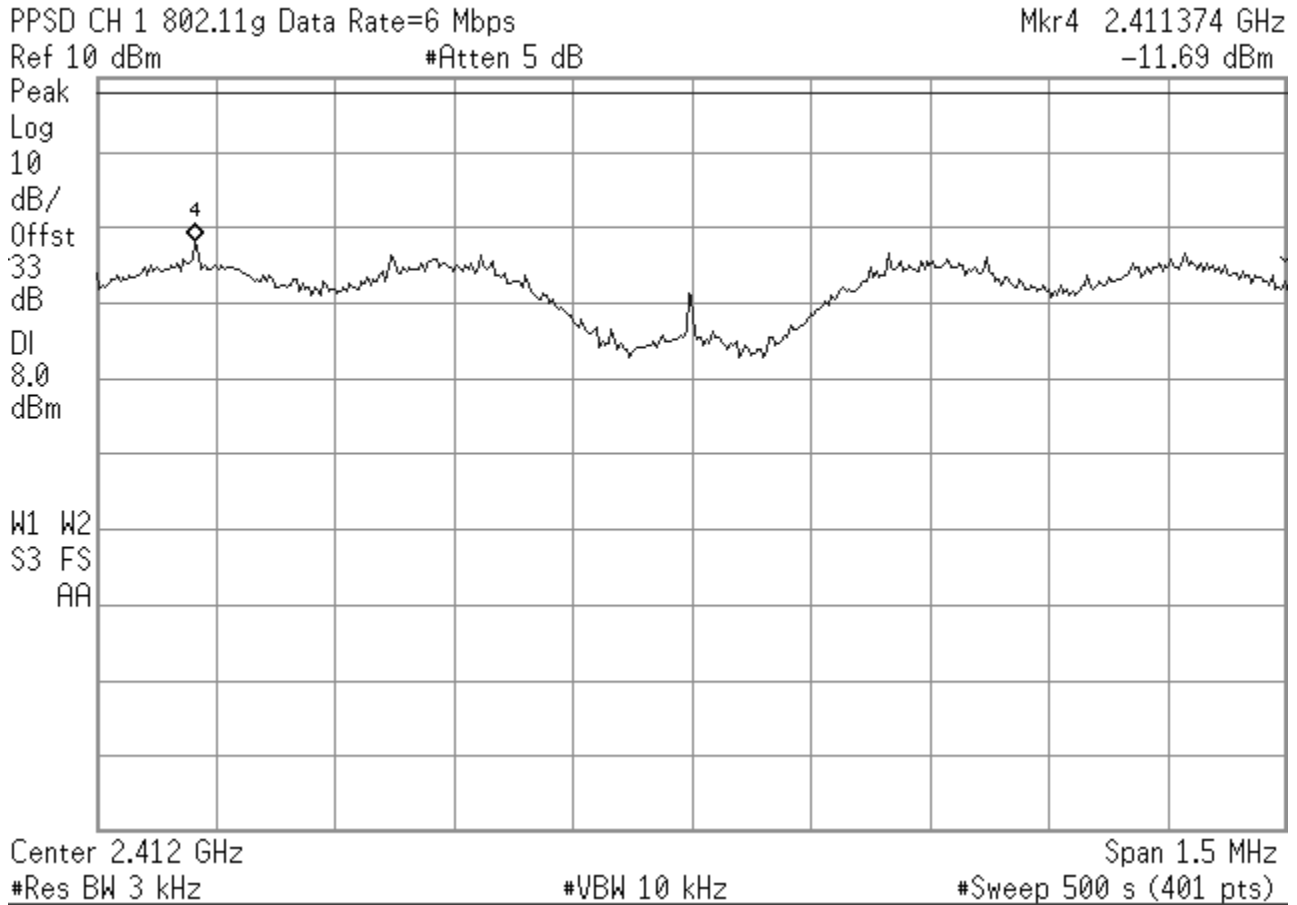

<b>Test Report S/N:</b>	052604-515/516KBC
<b>Test Date(s):</b>	28Jun04 - 29Jul04
<b>Test Type:</b>	FCC Part 15.247

Plot G-5 - PPSD Mid Channel (802.11g)

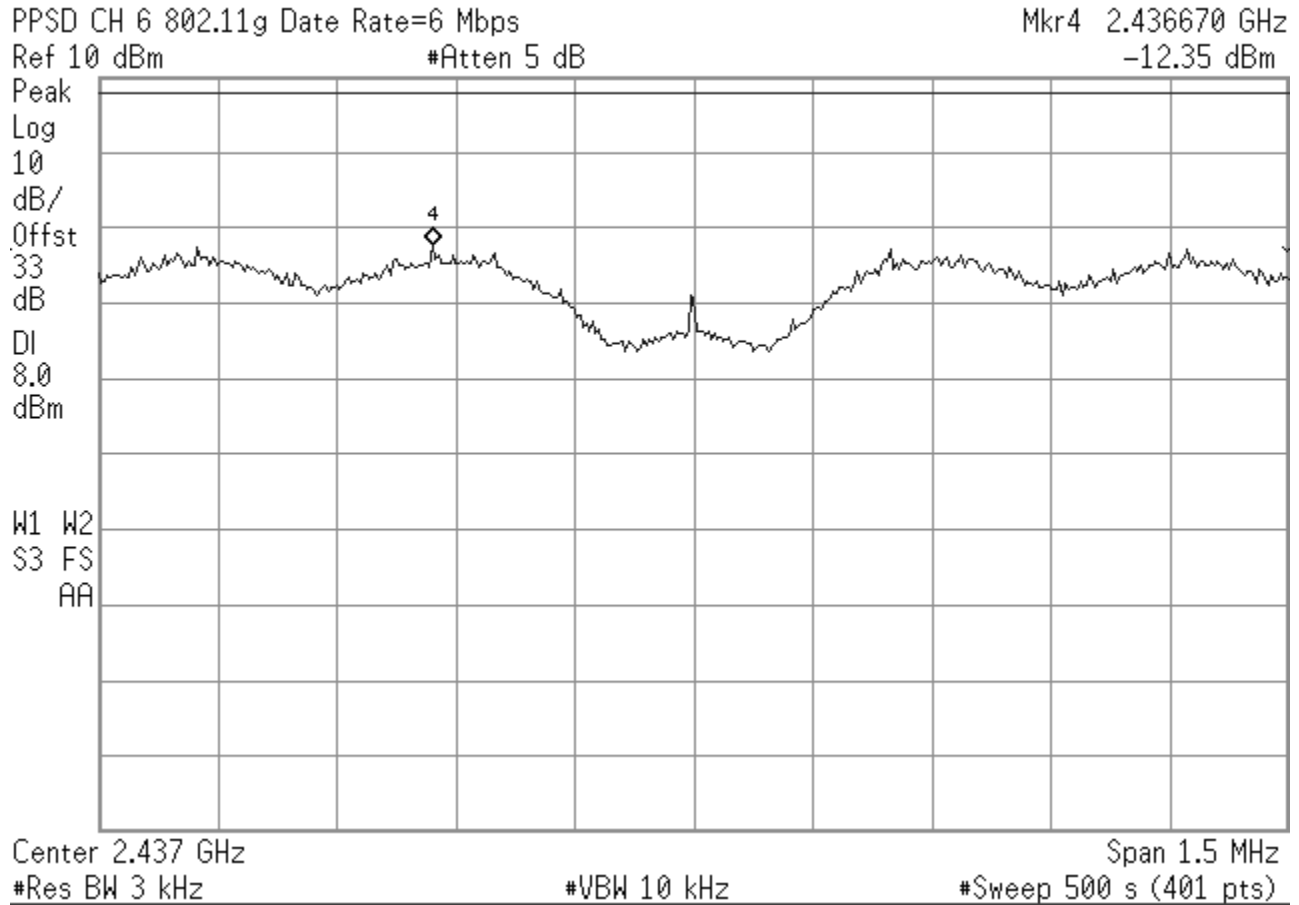

Test Report S/N:	052604-515/516KBC
Test Date(s):	28Jun04 - 29Jul04
Test Type:	FCC Part 15.247

Plot G-6 - PPSD High Channel (802.11g)

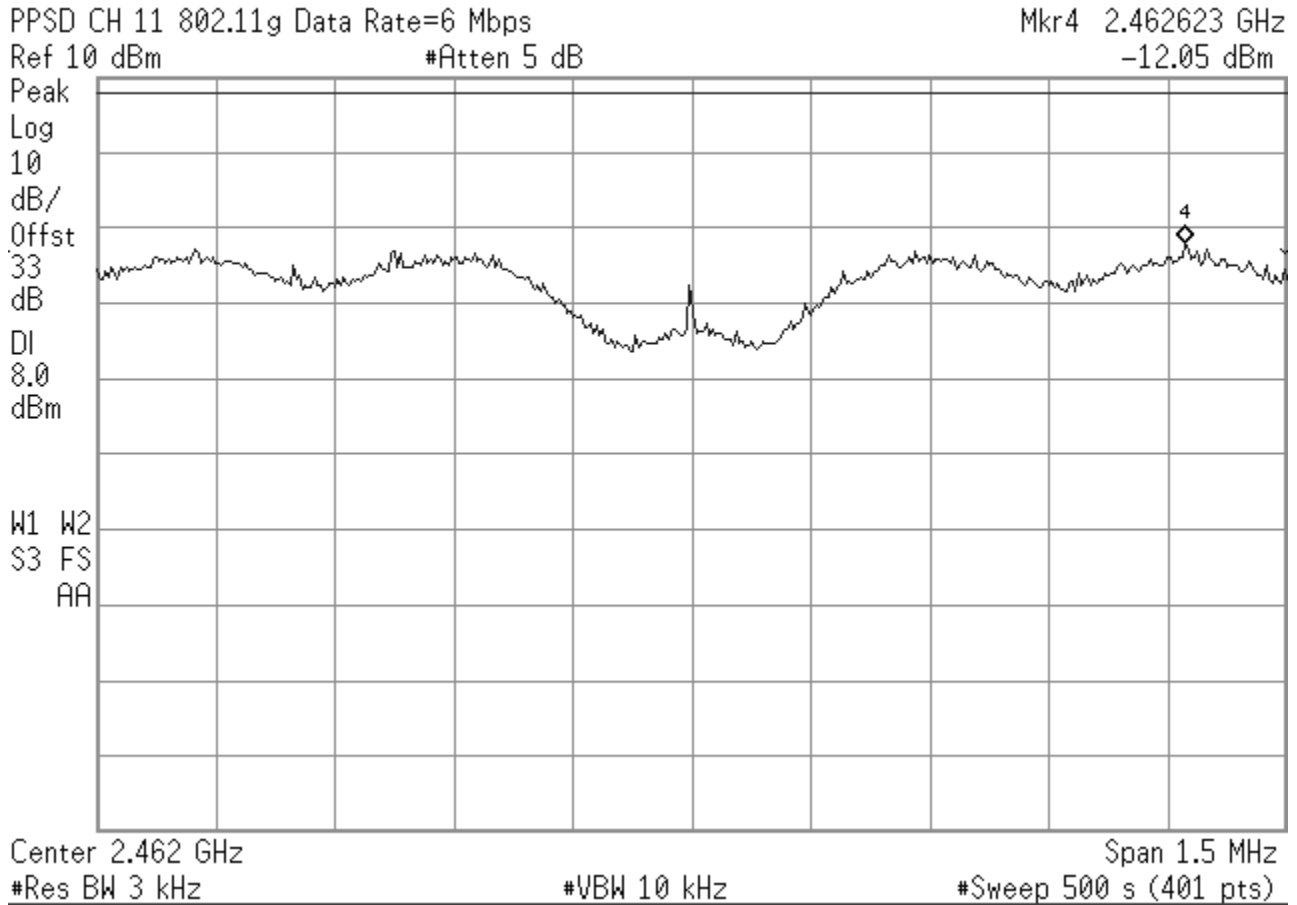

<b>Test Report S/N:</b>	052604-515/516KBC
<b>Test Date(s):</b>	28Jun04 - 29Jul04
<b>Test Type:</b>	FCC Part 15.247

**G.9. PASS/FAIL**

In reference to the results outlined in G.8 the DUT passes the requirements as stated in the reference standards as follows:  
FCC 15.247 (d): The peak power spectral density did not exceed +8 dBm in any 3 kHz band.

**G.10. SIGN-OFF**

I attest to the accuracy of the data. All measurements reported herein were performed by me and are correct to the best of my knowledge and belief. I assume full responsibility for the completeness of these measurements.



Russell Pipe  
Senior Compliance Technologist  
Celltech Labs Inc.

29Jul04

Date

<b>Test Report S/N:</b>	052604-515/516KBC
<b>Test Date(s):</b>	28Jun04 - 29Jul04
<b>Test Type:</b>	FCC Part 15.247

### Appendix H - Conducted Powerline Emissions Measurement

H.1. REFERENCES	
<b>Normative Reference Standard</b>	CFR 47 FCC Part 15 §15.207
<b>Procedure Reference</b>	ANSI C63.4

H.2. LIMITS		
§15.207: Compliance with the provisions of this paragraph shall be based on the measurement of the radio frequency voltage between each powerline and ground at the power terminal.		
Frequency of Emission (MHz)	Conducted Limit (dBuV)	
	Quasi-Peak	Average
0.15 – 0.5	66 to 56*	56 or 46*
0.50 – 5.0	56	46
5.0 – 30.0	60	50

H.3. ENVIRONMENTAL CONDITIONS	
<b>Temperature</b>	+26 ± 5 °C
<b>Humidity</b>	31 % ± 10% RH
<b>Barometric Pressure</b>	101.4 kpa

H.4. EQUIPMENT LIST					
ASSET NUMBER	MANUFACTURER	MODEL	DESCRIPTION	LAST CAL	CAL DUE
00063	HP	85662A	Spectrum Analyzer Display	na	na
00051	HP	8566B	Spectrum Analyzer RF Section	18May04	18May05
00049	HP	85650A	Quasi-Peak Adapter	18May04	18May05
00047	HP	85685A	Preselector	18May04	18May05
00083	EMCO	3825/2	Line Impedance Stabilization Network	29Apr04	29Apr05
00084	EMCO	3825/2	Line Impedance Stabilization Network	29Apr04	29Apr05

<b>Test Report S/N:</b>	052604-515/516KBC
<b>Test Date(s):</b>	28Jun04 - 29Jul04
<b>Test Type:</b>	FCC Part 15.247

<b>H.5. MEASUREMENT EQUIPMENT SETUP</b>	
<b>MEASUREMENT EQUIPMENT CONNECTIONS</b>	The conducted emissions were measured on each of the two AC powerline leads connected to the DUT's power supply brick. A two line LISN was used to make this measurement. A drawing of the equipment setup is shown in H.6
<b>MEASUREMENT EQUIPMENT SETTINGS</b>	<p>Each of the monitor ports from the 2-line LISN was connected in turn to the spectrum analyzer. The port not connected to the analyzer was terminated in a 50-ohm load. A prescan of the peak emission levels was made of the 150 kHz – 30 MHz range split into 4 equal frequency bands. The following were the spectrum analyzer settings:</p> <ul style="list-style-type: none"> <li>Start Frequency and Stop Frequency set by software for each of the four bands</li> <li>RBW: 100 kHz</li> <li>VBW: 300 kHz</li> <li>Sweep: 500 mS</li> </ul> <p>The resulting data from each band was corrected and collected by software and presented in the graphical representations shown in H.8 for the two leads.</p> <p>The frequency points with the highest 10 levels on each lead were used by software to optimize a set of 20 readings for each type of detector (peak, quasi-peak and average). This data was corrected by the software is presented in the tables shown in section H.8.</p>

<b>Test Report S/N:</b>	052604-515/516KBC
<b>Test Date(s):</b>	28Jun04 - 29Jul04
<b>Test Type:</b>	FCC Part 15.247

**H.6. SETUP PHOTOS**

Photograph H-1 – AC Powerline Conducted Emission Configuration



Photograph H-2 – AC Powerline Conducted Emission Cable Placement

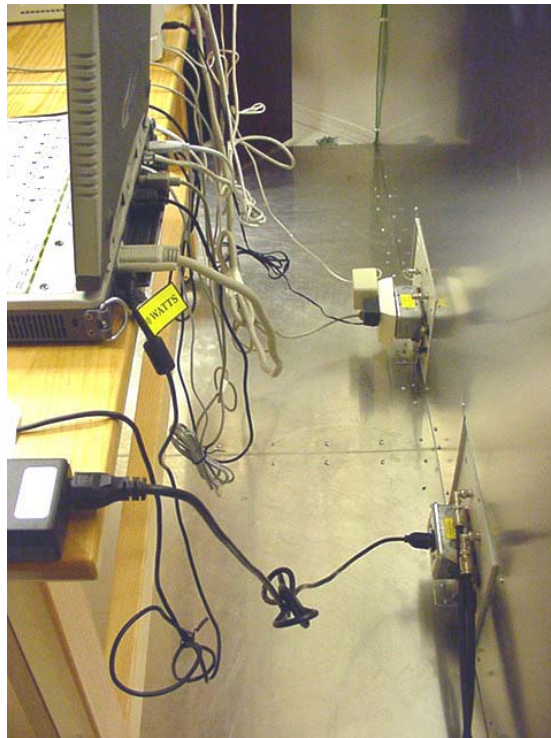

### H.7. SETUP DRAWING

Figure H-1 – Setup Drawing

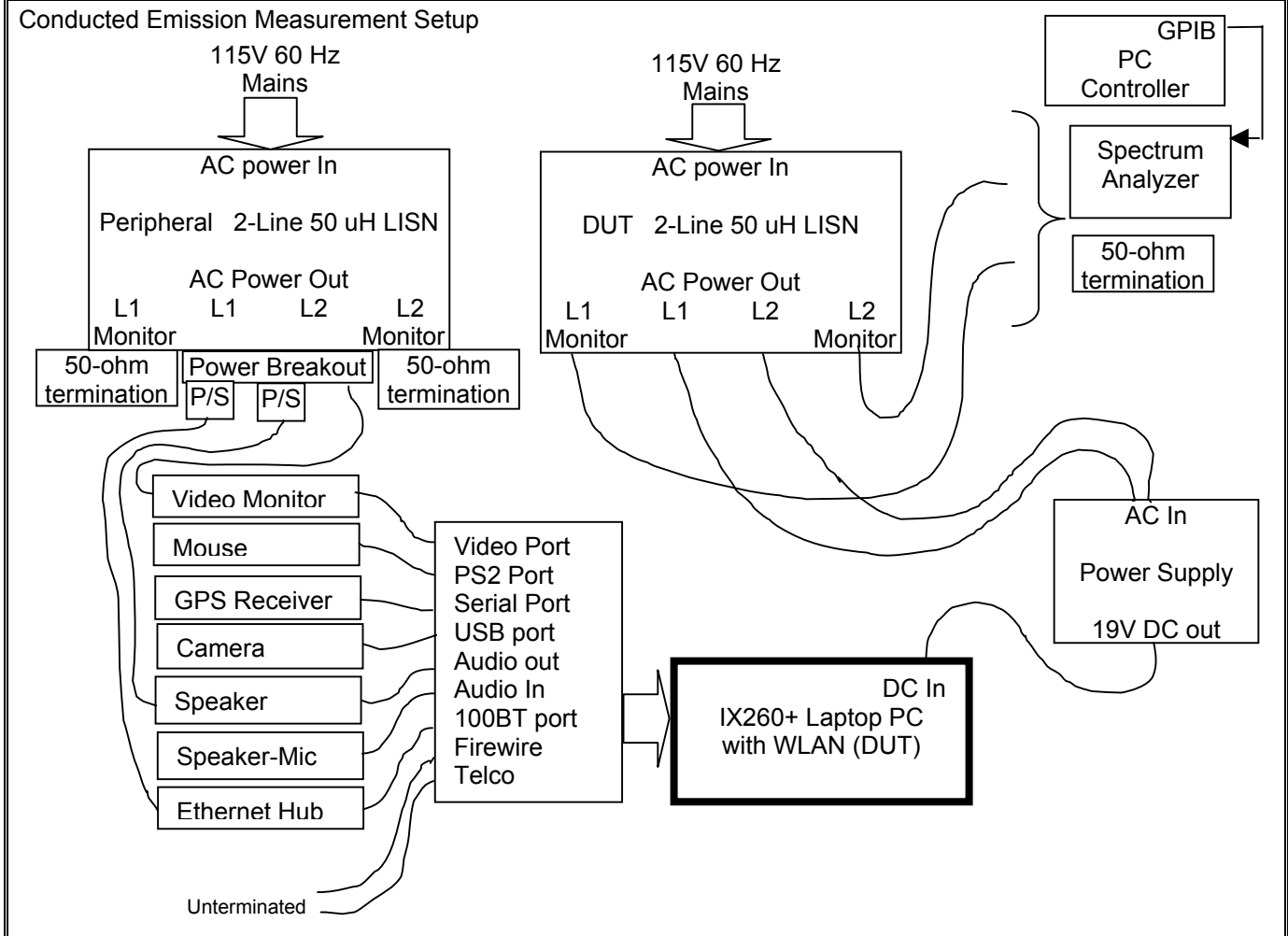

### H.8. DUT OPERATING DESCRIPTION

<b>WLAN:</b>	The WLAN was set to transmit at full power on Channel 1, Mode g 6 Mb/s
<b>PC:</b>	Other than operating the WLAN software and running MS windows, no PC exercising was performed.
<b>Peripherals:</b>	All peripherals were active, but no specific traffic was initiated.



<b>Test Report S/N:</b>	052604-515/516KBC
<b>Test Date(s):</b>	28Jun04 - 29Jul04
<b>Test Type:</b>	FCC Part 15.247

H.9. TEST RESULTS								
						<b>Standard:</b> FCC15.207		
Lead	Frequency	SA Level	CF	Emission Level	Detector	Limit	Margin	Pass/Fail
	MHz	dBuV	dB/m	dBuV/m	PK/QP/AVG	dBuV/m	dB	
L1	0.150	39.600	2.13	41.73	QP	66.00	24.27	PASS
L1	0.150	37.400	2.13	39.53	AVG	56.00	16.47	PASS
L1	2.737	41.800	0.28	42.08	QP	56.00	13.92	PASS
L1	2.737	41.900	0.28	42.18	AVG	46.00	3.82	PASS
L1	8.666	40.200	0.89	41.09	QP	56.59	15.49	PASS
L1	8.666	36.600	0.89	37.49	AVG	46.59	9.09	PASS
L1	24.575	22.400	2.88	25.28	PK	49.13	23.85	PASS
L1	24.575	20.000	2.88	22.88	AVG	49.13	26.25	PASS
L2	0.154	43.300	2.07	45.37	QP	65.89	20.52	PASS
L2	0.154	43.100	2.07	45.17	AVG	55.89	10.72	PASS
L2	3.191	42.500	0.29	42.79	QP	56.00	13.21	PASS
L2	3.191	42.400	0.29	42.69	AVG	46.00	3.31	PASS
L2	8.358	40.300	0.86	41.16	QP	56.54	15.38	PASS
L2	8.358	39.100	0.86	39.96	AVG	46.54	6.58	PASS
L2	24.575	23.400	2.89	26.29	QP	59.13	32.84	PASS
L2	24.575	20.200	2.89	23.09	AVG	49.13	26.04	PASS
<b>Calculations</b>								
CF = Correction Factor								
Emission Level = Measured Level + correction factor								
Margin = Limit – Emission Level								

Test Report S/N:	052604-515/516KBC
Test Date(s):	28Jun04 - 29Jul04
Test Type:	FCC Part 15.247

Plot H-1 - Line 1 Peak Conducted Powerline Emissions

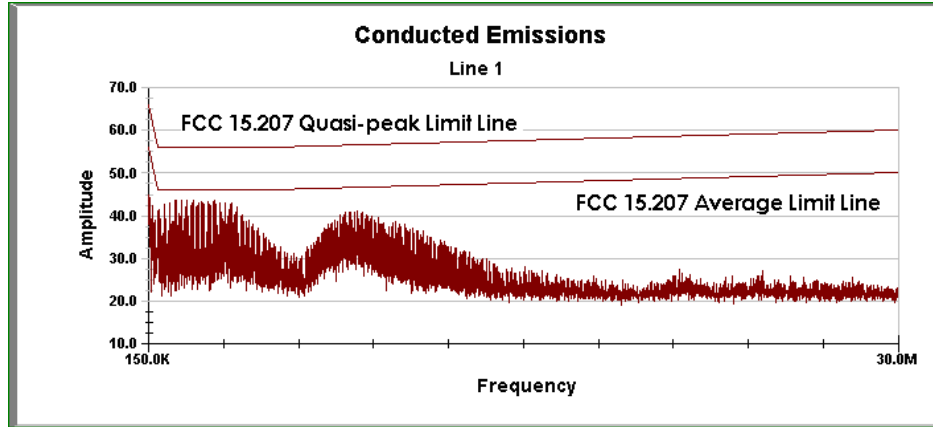

Plot H-2 - Line 2 Peak Conducted Powerline Emissions

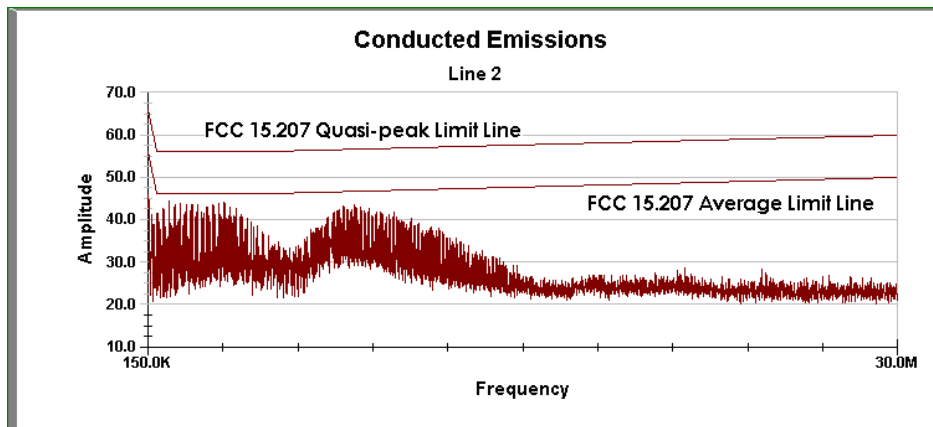

<b>Test Report S/N:</b>	052604-515/516KBC
<b>Test Date(s):</b>	28Jun04 - 29Jul04
<b>Test Type:</b>	FCC Part 15.247

**H.10. PASS/FAIL**

In reference to the results outlined in H.8 the DUT passes the requirements as stated in the reference standards as follows:  
 1) The pass-band gain does not exceed the nominal gain of +10.0 dB stated by the manufacturer by more than 1.0 dB.  
 2) The gain outside the 20dB bandwidth does not exceed the gain at the 20 dB point (-10.0 dB).

**H.11. SIGN-OFF**

I attest to the accuracy of the data. All measurements reported herein were performed by me and are correct to the best of my knowledge and belief. I assume full responsibility for the completeness of these measurements.



\_\_\_\_\_  
 Duane M. Friesen, C.E.T.  
 EMC Manager  
 Celltech Labs Inc.

\_\_\_\_\_  
 29Jul04  
 Date

<b>Test Report S/N:</b>	052604-515/516KBC
<b>Test Date(s):</b>	28Jun04 - 29Jul04
<b>Test Type:</b>	FCC Part 15.247

**END OF DOCUMENT**