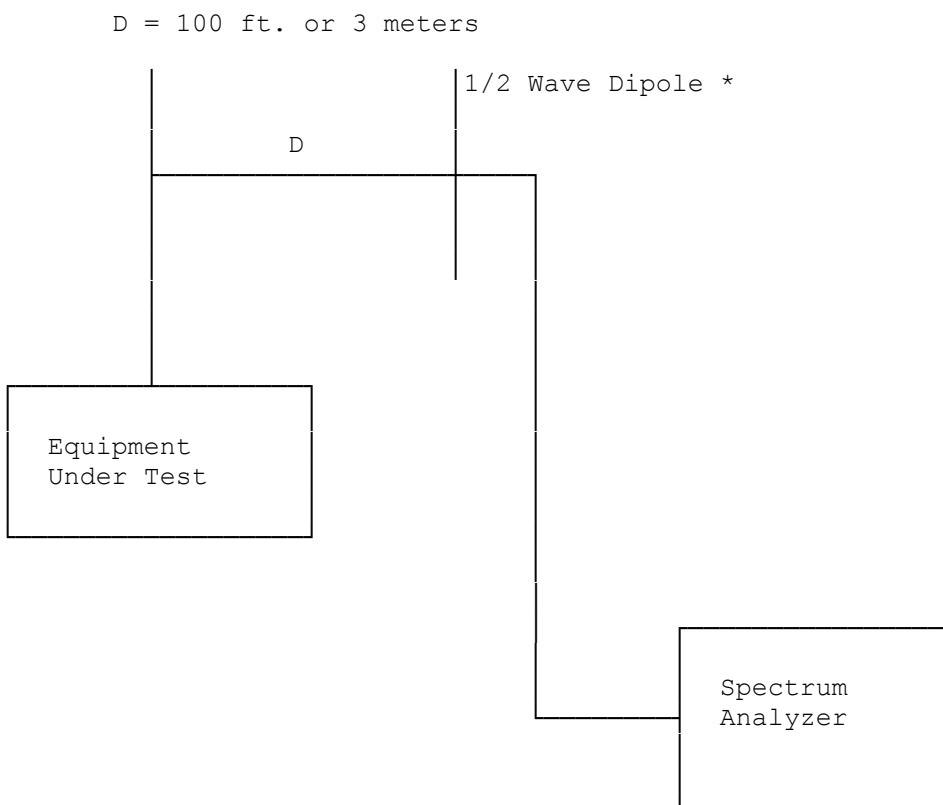

Exhibit VII. Test Set-Up Procedures

BLOCK DIAGRAM #1

Transmitter Radiated Spurious Emissions Test Set Up



See Equipment List for Equipment Specifications

- * 1/2 Wave Dipole 30-1000 MHz
Dual Ridged Guide Antenna or Broadband Log Periodic 1-10 GHz

Test Equipment List A

SPECTRUM TECHNOLOGY, INC.

<u>Equipment</u>	<u>Manufacturer/Model</u>	<u>Serial Number</u>	<u>Cal Date/Due Date</u>	
EMC Analyzer	Agilent Model: E7405A 9kHz – 26.5 GHz	MY42000087	10/23/03	10/23/04
Spectrum Analyzer	Hewlett-Packard 8562A 10kHz - 22 GHz	08562-60062	12/17/02	12/17/03
Amplifier 9 kHz-1300 MHz OPT H64	Hewlett-Packard 8447F	2727A02208	12/17/02	12/17/03
Amplifier .01 –26.5 GHz	Hewlett-Packard 83006A	3104A00167	12/18/02	12/18/03
Service Monitor	IFR FM/AM 500A 4103		---	
Oscilloscope	Kikusui C055060	6132295		---
Power Supply	Astron VS35	8601266		---
Voltmeter	Fluke 8020A	N2420658		---
Multimeter	Fluke 25	3710310		---
Wattmeter	Bird 43	56227		---
High pass filter 2-18 GHz	E/M, Inc.#FH-2/18	SN95-11		---
Notch filter 2-18 GHz	Custom notch 2.4 – 2.485 GHz	S002		---
Band Stop filter 2 – 18 GHz	Custom 1.7 – 2.5 GHz	S003		
RF Termination	Bird 8135	10004		---
Dual Phase LISN	STI per MP-4 50 ohm/50 uH	02	1/15/02	1/15/03
Dual Phase LISN	Compliance Design 50 ohm/50 uH	8012-50R-24-BNC	1/15/02	1/15/03
Audio Generator	Hewlett-Packard 205-AG	8689	---	
Thermometer	Fluke 52	3965185	---	
Test Line	Simulator, Teltone TLS-2	none	---	
Turn Table, RC	EMCO 1060-2M	8912-1415	---	
Antenna Mast, RC	Compliance Design, Inc.	M100	---	
Antennas:				
Dipole Set 30 – 1000 MHz	EMCO Model: 3121C	1335	03/26/00	09/26/04
Dipole Set 30 – 1000 MHz	EMCO Model: 3121C	1336	03/26/00	09/26/04
Bi-Conical 20 – 200 MHz	EMCO 3104	3763	reference only	
Bi-Conical 30 – 200 MHz	EMCO 3104C	9401-4635	reference only	
Log-Periodic 200 – 1000 MHz	EMCO 3146	1754	reference only	
Bi-ConiLog 28 – 5000 MHz	EMCO 3141	1125	05/20/02	11/20/03
Active Loop .1 - 30 MHz	EMCO 6502	9107-2645	reference only	
Dual Ridged Guide Ant. 1 – 18 GHz	Electro-metrics RGA-60	6225	1/106/03	1/10/04
Standard Gain Horn 18 – 26.5 GHz	EMCO 3160-09	21138	1/21/03	1/21/04

Rev. 09/03

Photographs of EUT set up at OATS facility July 28, 2004

Front View of IX260 PC – WLAN Antenna located internally in the upper left side of display. Bluetooth antenna located internally in the upper right side of the display. External blade antenna on the right side of display is for GC82.

Photo 1 of 4



Rear View of IX260 PC

Photo 2 of 4



Front View of IX260 PC – AC power line conducted emissions

Photo 3 of 4



Photo 4 of 4

