

TIMCO ENGINEERING INC.

849 NW State Road 45
Newberry, Florida 32669
<http://www.timcoengr.com>
888.472.2424 F 352.472.2030 email: tei@timcoengr.com



Test Report

Product Name: WLAN AND BLUE TOOTH

FCC ID: KBCIX100XUSIWLBT

Applicant:

ITRONIX
P.O. BOX 179
SPOKANE WASHINGTON 99210

Date Receipt: MARCH 26, 2004

Date Tested: APRIL 15, 2004

APPLICANT: ITRONIX
FCC ID: KBCIX100XUSIWLBT
REPORT #: I\ITRONIX\423AUT4\423AUT4TestReport.doc

COVER PAGE

TIMCO ENGINEERING INC.

849 NW State Road 45
Newberry, Florida 32669
<http://www.timcoengr.com>
888.472.2424 F 352.472.2030 email: tei@timcoengr.com

TABLE OF CONTENTS

TEST REPORT CONTAINING:

PAGE 1.....LETTER OF EXPLANATION
PAGE 2.....LIST OF TEST EQUIPMENT
PAGE 3.....TEST PROCEDURES

DSSS EMISSIONS

PAGE 4.....POWERLINE CONDUCTED INTERFERENCE
PAGE 5.....OCCUPIED BANDWIDTH AND POWER OUTPUT
PAGE 6.....6 dB BANDWIDTH PLOT
PAGE 7.....SPURIOUS EMISSIONS AT ANTENNA TERMINALS DATA &
METHOD OF MEASURING RF CONDUCTED
PAGE 8.....RADIATION INTERFERENCE TEST DATA
PAGE 9.....METHOD OF MEASURING RADIATED SPURIOUS EMISSIONS
PAGE 10-12.....RADIATED SPURIOUS EMISSIONS INTO ADJACENT
RESTRICTED BANDS
PAGE 13.....POWER SPECTRAL DENSITY
PAGE 14.....POWER SPECTRAL DENSITY PLOT

FHSS EMISSIONS

PAGE 15.....COVER PAGE FOR FHSS
PAGE 16.....POWERLINE CONDUCTED INTERFERENCE
PAGE 17.....NUMBER OF HOPPING CHANNELS
PAGE 18.....DWELL TIME
PAGE 19.....OCCUPIED BANDWIDTH
PAGE 20.....POWER OUTPUT
PAGE 21.....SPURIOUS EMISSIONS AT ANTENNA TERMINALS &
METHOD OF MEASURING COND. SPURIOUS EMISSIONS
PAGE 22.....FIELD STRENGTH OF SPURIOUS EMISSIONS
PAGE 23.....METHOD OF MEASURING RADIATED SPURIOUS EMISSIONS

EXHIBITS INCLUDED:

REQUEST FOR CONFIDENTIALITY LETTER
BLOCK DIAGRAM
SCHEMATICS
USERS MANUAL
LABEL SAMPLE
LABEL LOCATION
EXTERNAL PHOTOGRAPHS
INTERNAL PHOTOGRAPHS
OPERATIONAL DESCRIPTION
TEST SET UP PHOTOGRAPHS

APPLICANT: ITRONIX
FCC ID: KBCIX100XUSIWLBT
REPORT #: I\ITRONIX\423AUT4\423AUT4TestReport.doc

TABLE OF CONTENTS

TIMCO ENGINEERING INC.

849 NW State Road 45
Newberry, Florida 32669
<http://www.timcoengr.com>
888.472.2424 F 352.472.2030 email: tei@timcoengr.com

APRIL 15, 2004

Federal Communications Commission
Authorization and Evaluation Division
7435 Oakland Mills Road
Columbia, MD 21046

SUBJECT: ITRONIX

FCC ID: KBCIX100XUSIWLBT

To Whom It May Concern:

The attached application is for a hand held computing device that employs both wireless lan (802.11) and a blue tooth device.

The unit employs internal antennas. One for blue tooth and a separate antenna for the wireless lan. The wireless lan antenna has a gain of -4 dBi and the blue tooth antenna has a gain of +2.4 dBi.

Should you have any questions or require any further information with regards to this, please feel free to contact me.

Sincerely,

Mario R. de Aranzeta C.E.T.

MRD/sh
Encl.

APPLICANT: ITRONIX
FCC ID: KBCIX100XUSIWLBT
REPORT #: I\ITRONIX\423AUT4\423AUT4TestReport.doc

TIMCO ENGINEERING INC.

849 NW State Road 45
 Newberry, Florida 32669
 http://www.timcoengr.com
 888.472.2424 F 352.472.2030 email: tei@timcoengr.com

EMC Equipment List

Device	Manufacturer	Model	Serial Number	Cal/Char Date Listed	Due Date
3-Meter OATS	TEI	N/A	N/A	1/13/03	1/13/06
Biconnical Antenna	Eaton	94455-1	1057	CAL 3/18/03	3/18/05
Biconnical Antenna	Eaton	94455-1	1096	CAL 10/1/01	10/1/03
Double-Ridged Horn Antenna	Electro-Metrics	RGA-180	2319	CAL 2/17/03	2/17/05
LISN	Electro-Metrics	ANS-25/2	2604	CAL 10/9/01	10/9/03
LISN	Electro-Metrics	EM-7820	2682	CAL 3/12/03	3/12/05
Log-Periodic Antenna	Eaton	96005	1243	CAL 5/8/03	5/8/05
Log-Periodic Antenna	Electro-Metrics	EM-6950	632	CHAR 10/15/01	10/15/03
Log-Periodic Antenna	Electro-Metrics	LPA-25	1122	CAL 10/2/01	10/2/03
Log-Periodic Antenna	Electro-Metrics	LPA-30	409	CAL 3/4/03	3/4/05
Peak Power Meter	HP	8900C	2131A00545	CAL 7/2/03	7/2/05
Power Meter	HP	432A	1141A07655	CAL 4/15/03	4/15/05
Silver Tower Preamplifier	HP	8449B	3008A01075	CHAR 1/28/02	1/28/04
Silver Tower Quasi-Peak Adapter	HP	85650A	3303A01844	CAL 10/14/02	10/14/04
Silver Tower RF Preselector	HP	85685A	2620A00294	CAL 10/14/02	10/14/04
Silver Tower Spectrum Analyzer	HP	8566B Opt 462	3552A22064 3638A08608	CAL 10/14/02	10/14/04
Tan Tower Preamplifier	HP	8449B-H02	3008A00372	CHAR 3/4/01	3/4/03
Tan Tower Quasi-Peak Adapter	HP	85650A	3303A01690	CAL 8/31/01	8/31/03
Tan Tower RF Preselector	HP	85685A	3221A01400	CAL 8/31/01	8/31/03
Tan Tower Spectrum Analyzer	HP	8566B Opt 462	3138A07786 3144A20661	CAL 8/31/01	8/31/03
Harmonic Mixer	HP	11970K	3003A04991	N/A	N/A
HORN	SYSTRON DONNOR	DBE-520-20	N/A	N/A	N/A

APPLICANT: ITRONIX
 FCC ID: KBCIX100XUSIWLBT
 REPORT #: I\ITRONIX\423AUT4\423AUT4TestReport.doc

TIMCO ENGINEERING INC.

849 NW State Road 45
Newberry, Florida 32669
<http://www.timcoengr.com>
888.472.2424 F 352.472.2030 email: tei@timcoengr.com

TEST PROCEDURE

GENERAL: This report shall NOT be reproduced except in full without the written approval of TIMCO ENGINEERING, INC.

POWER LINE CONDUCTED INTERFERENCE: The procedure used was ANSI STANDARD C63.4-1992 using a 50uH LISN. Both lines were observed with the UUT transmitting. The bandwidth of the spectrum analyzer was 10kHz with an appropriate sweep speed. The ambient temperature of the UUT was 76°F with a humidity of 55%.

BANDWIDTH 6.0dB: The measurements were made with the spectrum analyzer's resolution bandwidth (RBW)=1.0MHz and the video bandwidth (VBW) =3.0MHz and the span set as shown on plot.

POWER OUTPUT: The RF power output was measured at the antenna feed point using a peak power meter.

ANTENNA CONDUCTED EMISSIONS: The RBW=100 kHz, VBW=300 kHz and the span set to 10.0MHz and the spectrum was scanned from 30MHz to the 10th Harmonic of the fundamental. Above 1.0GHz the resolution bandwidth was 1.0MHz and the VBW = 3.0MHz and the span to 50MHz.

RADIATION INTERFERENCE: The test procedure used was ANSI STANDARD C63.4-1992 using a HEWLETT PACKARD spectrum analyzer with a pre-selector. The bandwidth (RBW) of the spectrum analyzer was 100kHz up to 1GHz and 1.0MHz above 1GHz with an appropriate sweep speed. The VBW above 1.0GHz was = 3.0MHz. The analyzer was calibrated in dB above a microvolt at the output of the antenna. The ambient temperature of the UUT was 76°F with a humidity of 55%.

TIMCO ENGINEERING INC.

849 NW State Road 45
Newberry, Florida 32669
<http://www.timcoengr.com>
888.472.2424 F 352.472.2030 email: tei@timcoengr.com

APPLICANT: ITRONIX
FCC ID: KBCIX100XUSIWLBT
NAME OF TEST: POWER LINE CONDUCTED INTERFERENCE
RULES PART NO.: 15.207

REQUIREMENTS:	QUASI-PEAK	AVERAGE
.15 - 0.5 MHz	66-56 dBuV	56-46 dBuV
0.5 - 5.0	56	46
5.0 - 30.	60	50

TEST PROCEDURE: ANSI STANDARD C63.4-1992. The spectrum was scanned from .15 to 30 MHz.

TEST DATA (LINE 1):

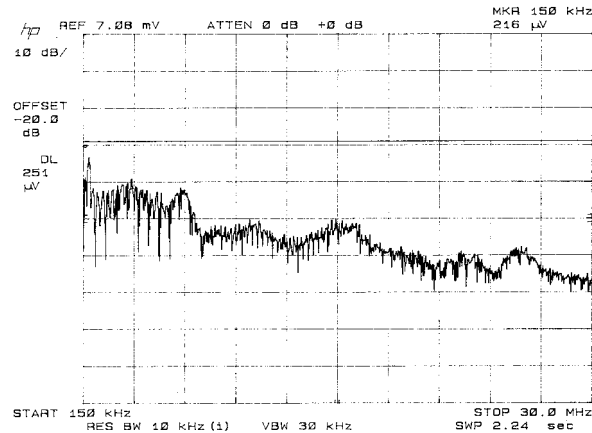

LINE 2

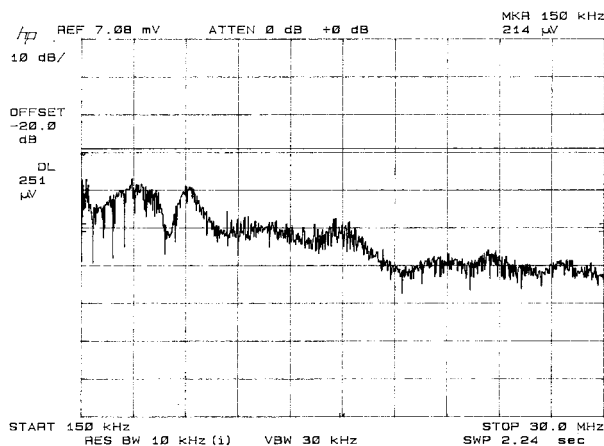

TEST RESULTS: Both lines were observed. The measurements indicate that the unit DOES appear to meet the FCC requirements for this class of equipment.

APPLICANT: ITRONIX
FCC ID: KBCIX100XUSIWLBT
REPORT #: I\ITRONIX\423AUT4\423AUT4TestReport.doc

TIMCO ENGINEERING INC.

849 NW State Road 45
Newberry, Florida 32669
<http://www.timcoengr.com>
888.472.2424 F 352.472.2030 email: tei@timcoengr.com

APPLICANT: ITRONIX
FCC ID: KBCIX100XUSIWLBT
NAME OF TEST: 6.0dB BANDWIDTH
RULES PART NO.: 15.247(a)(2)
REQUIREMENTS: The 6.0dB bandwidth must be greater than 500 kHz.

MEASUREMENT DATA: See the following plots

NAME OF TEST: POWER OUTPUT
RULES PART NO.: 15.247(b) 1.0Watt or +30dBm
MEASUREMENT: 14 dBm

15.247(c) Method of Measuring RF Power output: The Peak power Sensor was connected in place of the antenna.

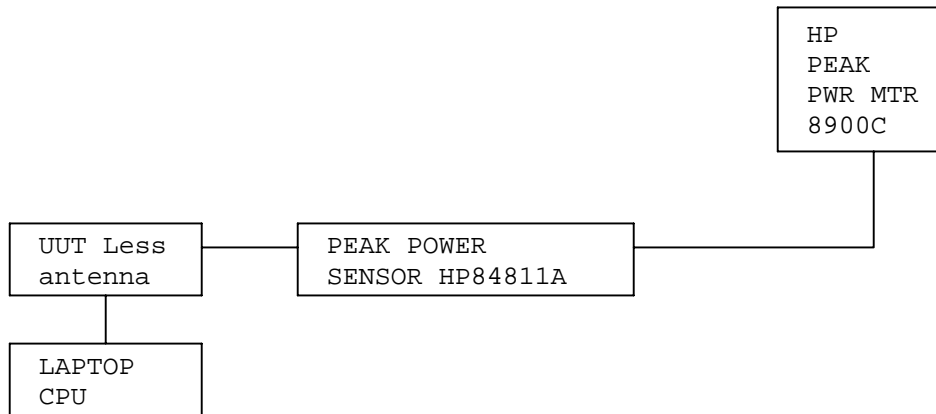

3 channels were measured and the worst case is reported here

APPLICANT: ITRONIX
FCC ID: KBCIX100XUSIWLBT
REPORT #: I\ITRONIX\423AUT4\423AUT4TestReport.doc

TIMCO ENGINEERING INC.

849 NW State Road 45
Newberry, Florida 32669
http://www.timcoengr.com
888.472.2424 F 352.472.2030 email: tei@timcoengr.com

6 dB BANDWIDTH

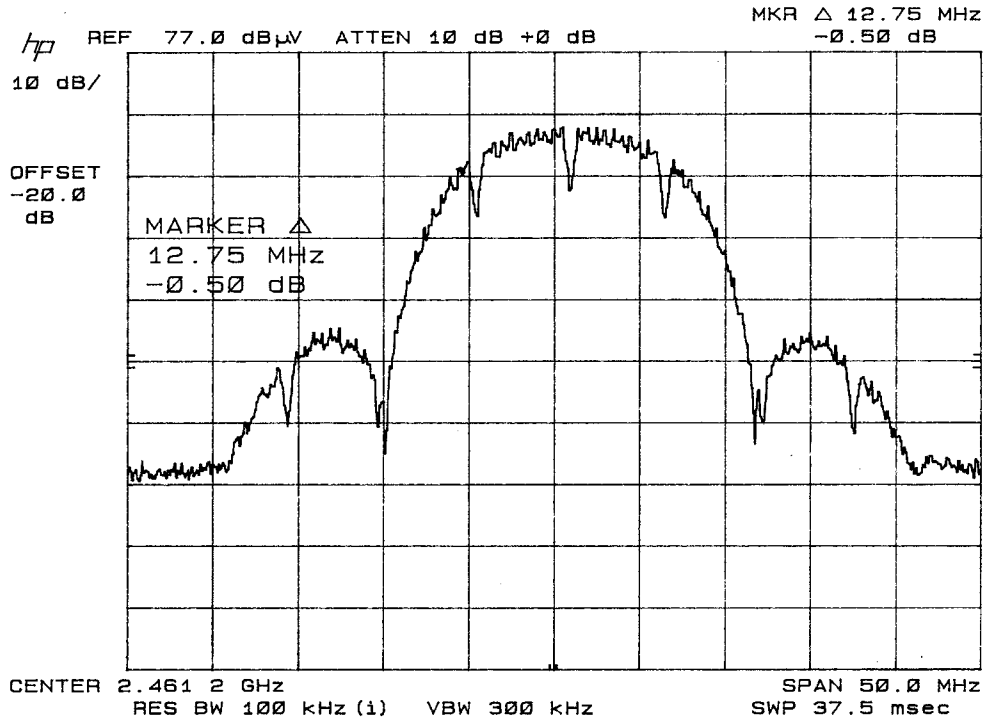

TIMCO ENGINEERING INC.

849 NW State Road 45
Newberry, Florida 32669
<http://www.timcoengr.com>
888.472.2424 F 352.472.2030 email: tei@timcoengr.com

NAME OF TEST: SPURIOUS EMISSIONS AT ANTENNA TERMINALS

REQUIREMENTS: Emissions must be at least 20dB down from the highest emission level within the authorized band as measured with a 100 kHz RBW.

TEST DATA:

TF	EF	dB below carrier	TF	EF	dB below carrier
2412	2412	0	2437	2437	0.0
	4824	76		4874	75.6
	7236	89		7311	89.6
	7648	98		9748	92.8

TF	EF	dB below carrier
2462	2462	0.0
	4924	76.7
	7386	87.9
	9848	100.0
	1715.8	72.3
	1693	81.9
	1980	81.8
	2309	72.4
	2611.9	72.3
	2753	72.8

NOTE: THE SPECTRUM WAS SCANNED TO THE TENTH HARMONIC.

15.247(c) Method of Measuring RF Conducted Spurious Emissions

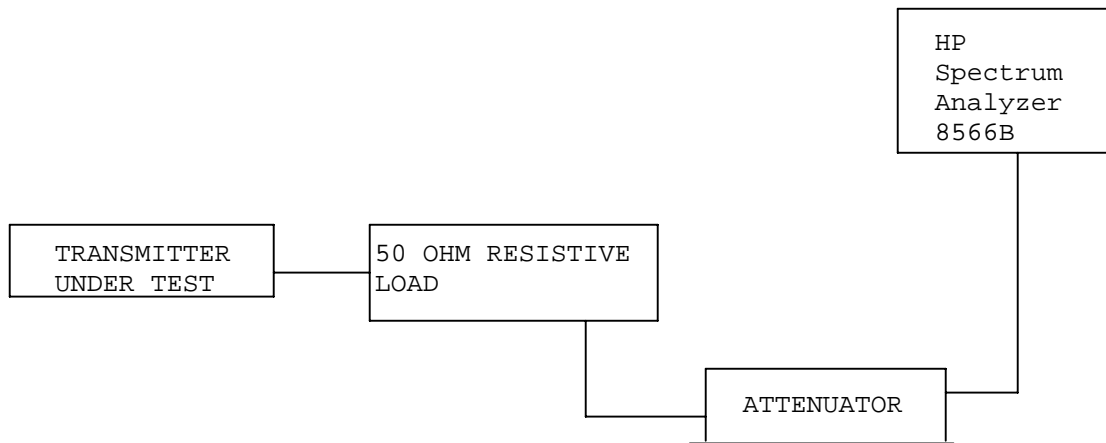

APPLICANT: ITRONIX
FCC ID: KBCIX100XUSIWLBT
REPORT #: I\ITRONIX\423AUT4\423AUT4TestReport.doc

TIMCO ENGINEERING INC.

849 NW State Road 45
Newberry, Florida 32669
http://www.timcoengr.com
888.472.2424 F 352.472.2030 email: tei@timcoengr.com

15.247(c), 15.205 & 15.209(b) Field strength of spurious emissions:

REQUIREMENTS:

FIELD STRENGTH of Fundamental: 902-928MHz 2.4-2.4835GHz	FIELD STRENGTH of Harmonics 127.37dBuV/m 54 dBuV/m @3m	S15.209 30 - 88 MHz 40 dBuV/m @3M 88 -216 MHz 43.5 216 -960 MHz 46 ABOVE 960 MHz 54dBuV/m
--	---	---

EMISSIONS RADIATED OUTSIDE OF THE SPECIFIED FREQUENCY BANDS, EXCEPT FOR HARMONICS, SHALL BE ATTENUATED BY AT LEAST 50 dB BELOW THE LEVEL OF THE FUNDAMENTAL OR TO THE GENERAL RADIATED EMISSION LIMITS IN 15.209, WHICHEVER IS THE LESSER ATTENUATION.

REQUIREMENTS FOR EMISSIONS THAT FALL IN A RESTRICTED BAND:

FIELD STRENGTH LIMITS FOR PEAK READINGS:	74 dBuV/m
FIELD STRENGTH LIMITS FOR AVERAGE READINGS:	54 dBuV/m

TEST DATA:

Tuned Frequency MHz	Emission Frequency MHz	Meter Reading dBuV	Ant. Polarity	Coax Loss dB	Correction Factor dB	Field Strength dBuV/m	Margin dB
2,412.0	2,412.00	72.8	H	1.91	29.26	103.97	23.40
2,412.0	4,824.00R	14.8	H	2.65	34.14	51.59AV	2.41
2,412.0	4,824.00R	27.2	H	2.65	34.14	63.99PK	10.01
2,437.0	2,321.00	0.8	H	1.86	29.11	31.77	22.23
2,437.0	2,321.00	12.0	H	1.86	29.11	42.97	11.03
2,437.0	2,437.00	67.9	V	1.92	29.31	99.13	28.24
2,437.0	2,437.00	71.5	H	1.92	29.30	102.72	24.65
2,437.0	4,873.00R	7.3	V	2.66	34.19	44.15AV	9.85
2,437.0	4,873.00R	10.0	H	2.66	34.29	46.95AV	7.05
2,437.0	4,873.00R	18.1	V	2.66	34.19	54.95PK	19.05
2,437.0	4,873.00R	22.2	H	2.66	34.29	59.15PK	14.85
2,462.0	2,462.00	72.3	H	1.93	29.34	103.57	23.80
2,462.0	4,924.00R	11.8	H	2.68	34.46	48.94AV	5.06
2,462.0	4,924.00R	25.1	H	2.68	34.46	62.24PK	11.76

Harmonics were checked through the 10th harmonic

APPLICANT: ITRONIX
FCC ID: KBCIX100XUSIWLBT
REPORT #: I\ITRONIX\423AUT4\423AUT4TestReport.doc

TIMCO ENGINEERING INC.

849 NW State Road 45
Newberry, Florida 32669
<http://www.timcoengr.com>
888.472.2424 F 352.472.2030 email: tei@timcoengr.com

Method of Measuring Radiated Spurious Emissions

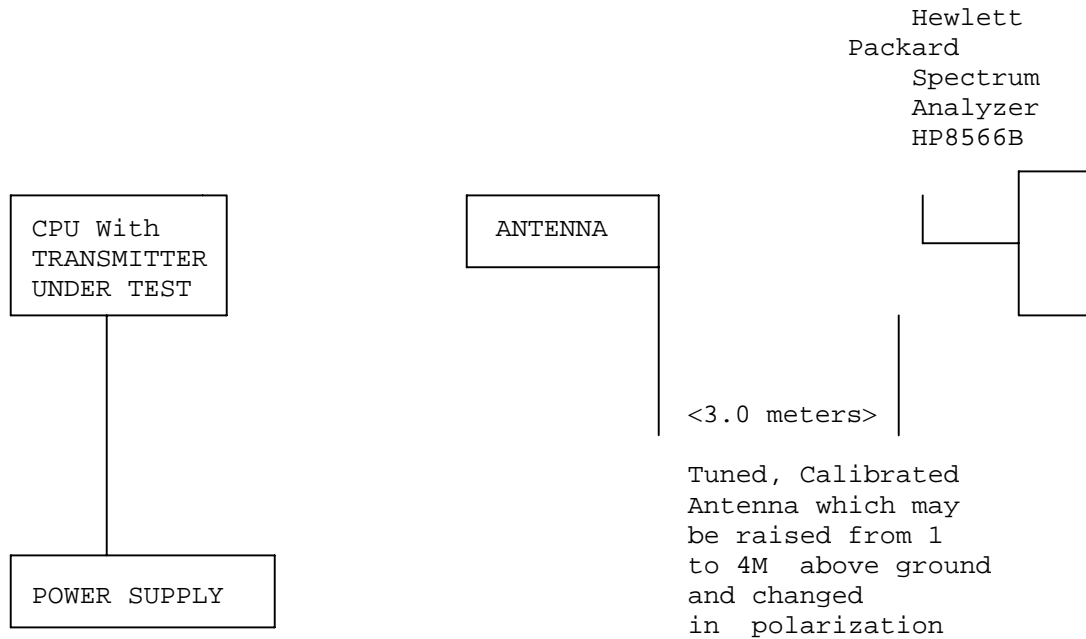

Equipment placed 80cm above ground on a rotatable platform.

METHOD OF MEASUREMENT: The procedure used was ANSI STANDARD C63.4-1992 & the FCC/OET Guidance on Measurements for Direct Sequence Spread Spectrum Systems - Public Notice 54797 Dated July 12, 1995. Measurements were made at the open field test site of TIMCO ENGINEERING INC. located at 849 N.W. State Road 45, Newberry, FL 32669.

APPLICANT: ITRONIX
FCC ID: KBCIX100XUSIWLBT
REPORT #: I\ITRONIX\423AUT4\423AUT4TestReport.doc

TIMCO ENGINEERING INC.

849 NW State Road 45
Newberry, Florida 32669
<http://www.timcoengr.com>
888.472.2424 F 352.472.2030 email: tei@timcoengr.com

APPLICANT: ITRONIX

FCC ID: KBCIX100XUSIWLBT

NAME OF TEST: RADIATED SPURIOUS EMISSIONS INTO ADJACENT RESTRICTED BAND

REQUIREMENTS: Emissions that fall in the restricted bands (15.205). These emissions must be less than or equal to 500 uV/m (54 dBuV/m).

TEST PROCEDURE: An in band field strength measurement of the fundamental Emission using the RBW and detector function required by C63.4-2000 and FCC Rules. The procedure was repeated with an average detector and a plot made. The calculated field strength in the adjacent restricted band is presented below.

Average	Average
CHANNEL 1	CHANNEL 11
FREQUENCY: 2375.78 MHz	FREQUENCY: 2483.00 MHz
+ 7.00 dBuV from plot	+ 7.70 dBuV from plot
+29.20 dB ACF	+34.14 dB ACF
+ 1.85 dB Coax Loss	+ 2.65 dB Coax Loss
<hr/>	<hr/>
+38.05 dBuV	+44.49 dBuV
Peak	Peak
CHANNEL 1	CHANNEL 11
FREQUENCY: 2375.78 MHz	FREQUENCY: 2483.00 MHz
+20.10 dBuV from plot	+20.30 dBuV from plot
+29.20 dB ACF	+34.14 dB ACF
+ 1.85 dB Coax Loss	+ 2.65 dB Coax Loss
<hr/>	<hr/>
+51.15 dBuV	+57.09 dBuV

TIMCO ENGINEERING INC.

849 NW State Road 45
Newberry, Florida 32669
<http://www.timcoengr.com>
888.472.2424 F 352.472.2030 email: tei@timcoengr.com

AVERAGE

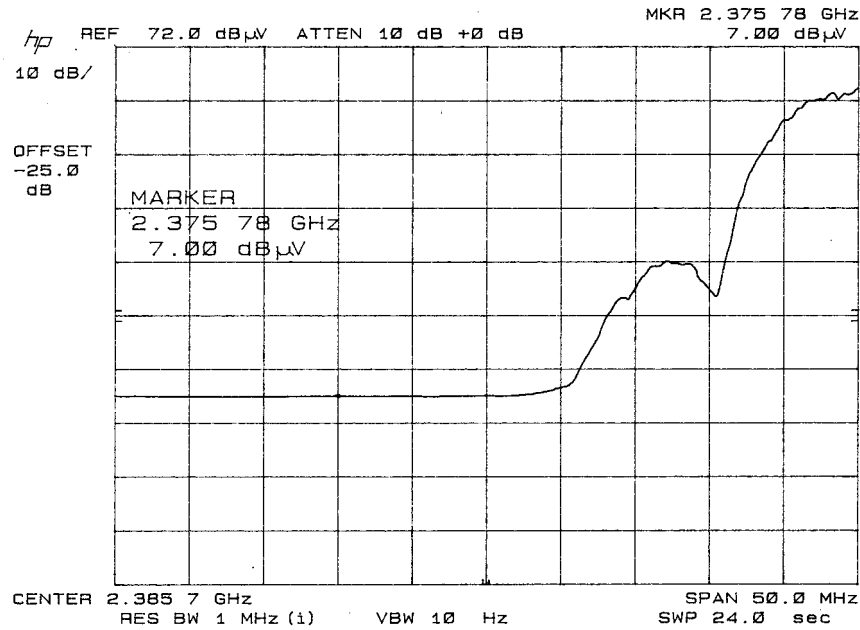

PEAK

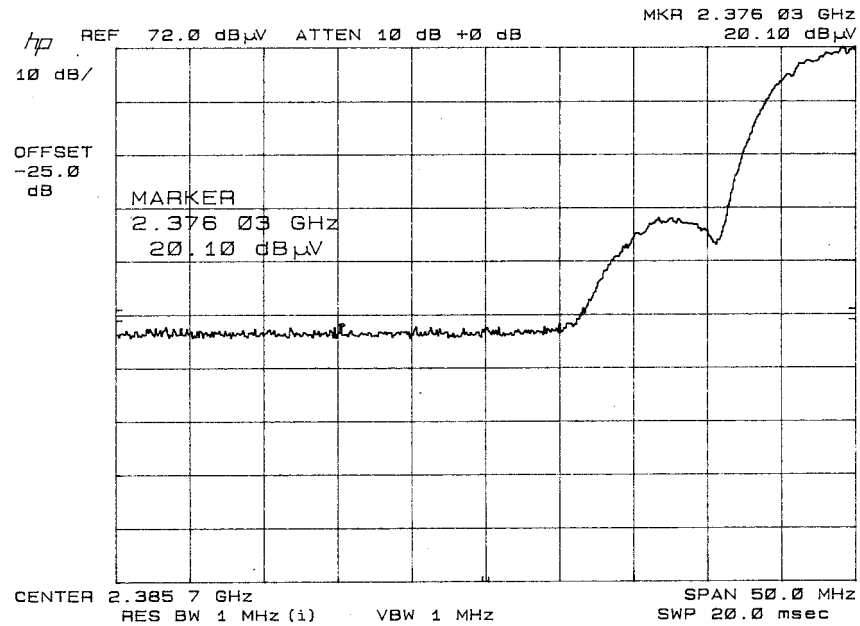

APPLICANT: ITRONIX
FCC ID: KBCIX100XUSIWLBT
REPORT #: I\ITRONIX\423AUT4\423AUT4TestReport.doc

TIMCO ENGINEERING INC.

849 NW State Road 45
Newberry, Florida 32669
<http://www.timcoengr.com>
888.472.2424 F 352.472.2030 email: tei@timcoengr.com

AVERAGE

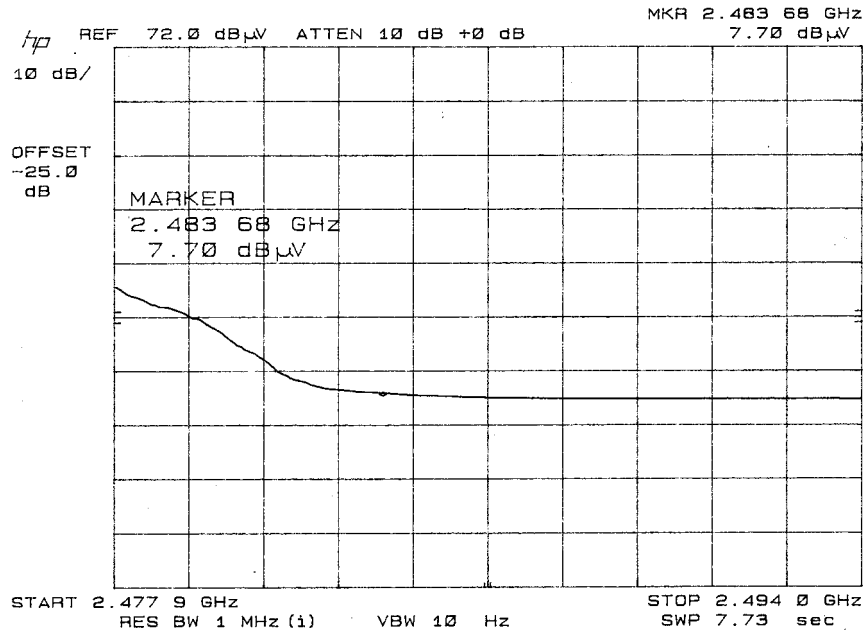

PEAK

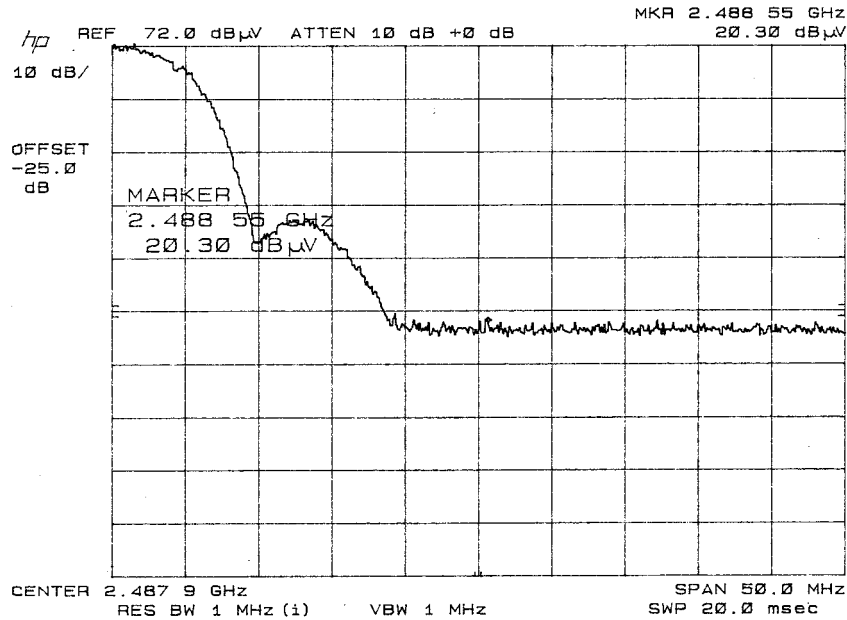

APPLICANT: ITRONIX
FCC ID: KBCIX100XUSIWLBT
REPORT #: I\ITRONIX\423AUT4\423AUT4TestReport.doc

TIMCO ENGINEERING INC.

849 NW State Road 45
Newberry, Florida 32669
<http://www.timcoengr.com>
888.472.2424 F 352.472.2030 email: tei@timcoengr.com

APPLICANT: ITRONIX
FCC ID: KBCIX100XUSIWLBT
NAME OF TEST: POWER SPECTRAL DENSITY
RULES PART NO.: 15.247(d)
REQUIREMENTS: The peak level measured must be no greater than +8.0dBm.
DATA: SEE THE FOLLOWING PLOTS

-59 dBm	from plot
+35 dB	Correction Factor to 1 Hz
<hr/>	
-24 dBm	

3 channels were measured and the worst case is reported here

APPLICANT: ITRONIX
FCC ID: KBCIX100XUSIWLBT
REPORT #: I\ITRONIX\423AUT4\423AUT4TestReport.doc

TIMCO ENGINEERING INC.

849 NW State Road 45
Newberry, Florida 32669
<http://www.timcoengr.com>
888.472.2424 F 352.472.2030 email: tei@timcoengr.com

POWER SPECTRAL DENSITY PLOT

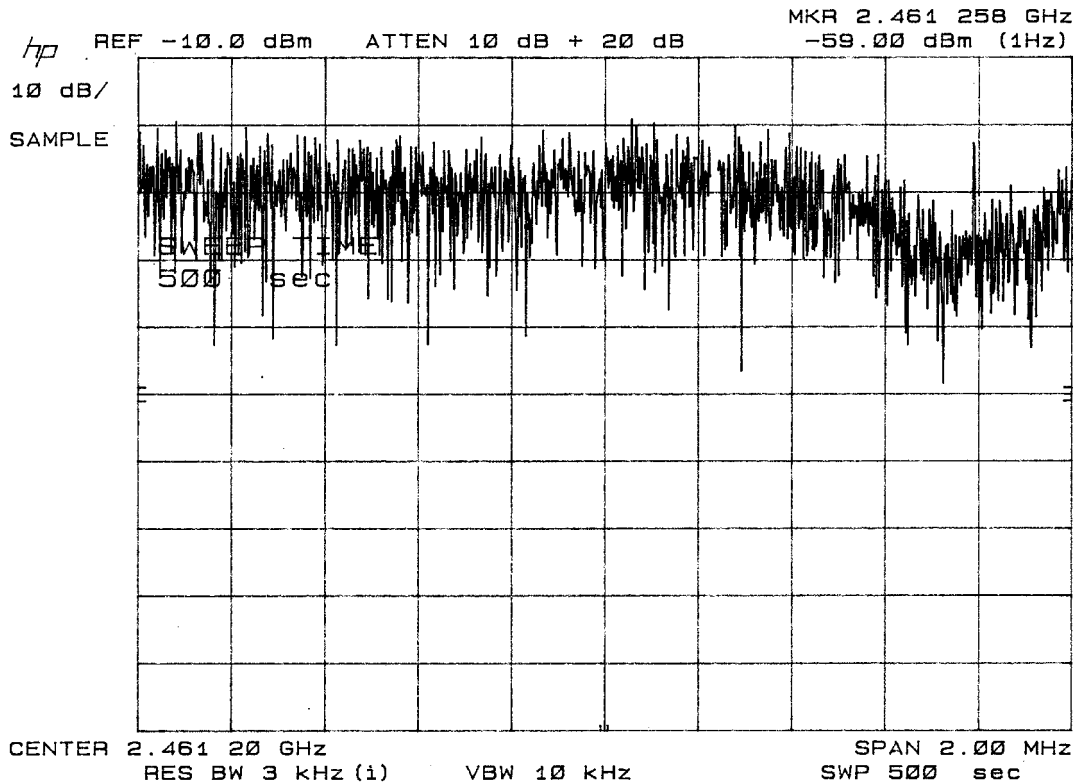

APPLICANT: ITRONIX
FCC ID: KBCIX100XUSIWLBT
REPORT #: I\ITRONIX\423AUT4\423AUT4TestReport.doc

TIMCO ENGINEERING INC.

849 NW State Road 45
Newberry, Florida 32669
<http://www.timcoengr.com>
888.472.2424 F 352.472.2030 email: tei@timcoengr.com

ITRONIX
P.O. BOX 179
SPOKANKE, WASHINGTON 99210

FCC ID: KBCIX100XUSIWLBT

FHSS EMISSIONS
(BLUETOOTH)

APPLICANT: ITRONIX
FCC ID: KBCIX100XUSIWLBT
REPORT #: I\ITRONIX\423AUT4\423AUT4TestReport.doc

TIMCO ENGINEERING INC.

849 NW State Road 45
Newberry, Florida 32669
<http://www.timcoengr.com>
888.472.2424 F 352.472.2030 email: tei@timcoengr.com

APPLICANT: ITRONIX
FCC ID: KBCIX100XUSIWLBT
NAME OF TEST: POWER LINE CONDUCTED INTERFERENCE
RULES PART NO.: 15.207

REQUIREMENTS:	QUASI-PEAK	AVERAGE
.15 - 0.5 MHz	66-56 dBuV	56-46 dBuV
0.5 - 5.0	56	46
5.0 - 30.	60	50

TEST PROCEDURE: ANSI STANDARD C63.4-1992. The spectrum was scanned from .15 to 30 MHz.

TEST DATA - LINE 1

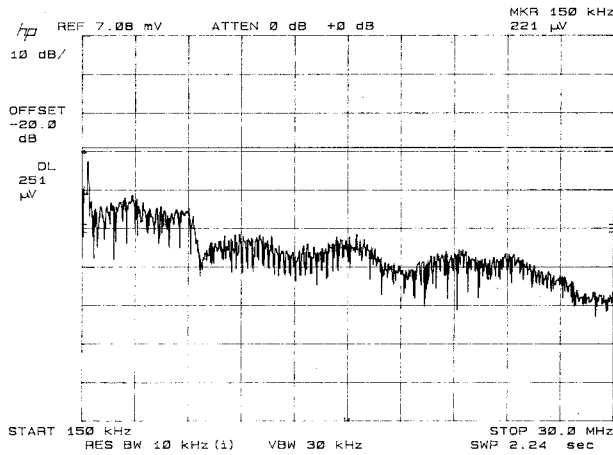

LINE 2

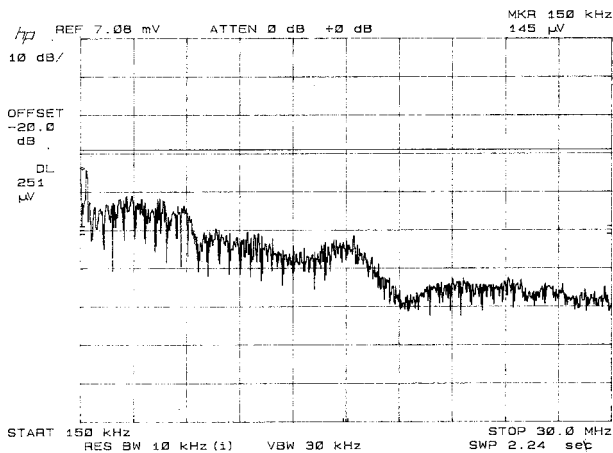

TEST RESULTS: Both lines were observed. The measurements indicate that the unit DOES appear to meet the FCC requirements for this class of equipment.

APPLICANT: ITRONIX
FCC ID: KBCIX100XUSIWLBT
REPORT #: I\ITRONIX\423AUT4\423AUT4TestReport.doc

TIMCO ENGINEERING INC.

849 NW State Road 45
Newberry, Florida 32669
http://www.timcoengr.com
888.472.2424 F 352.472.2030 email: tei@timcoengr.com

15.247(a)(1):

Number of Hopping Channels:

The number of hops is 79 hops at a separation of 1 MHz, the requirement in the 2400 - 2483.5 MHz band is a minimum of 75 hops.

NUMBER OF CHANNELS

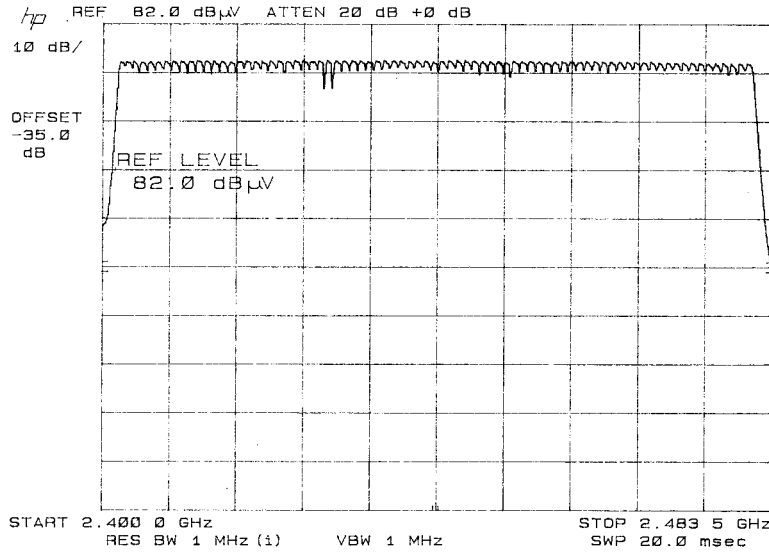

CARRIER FREQUENCY

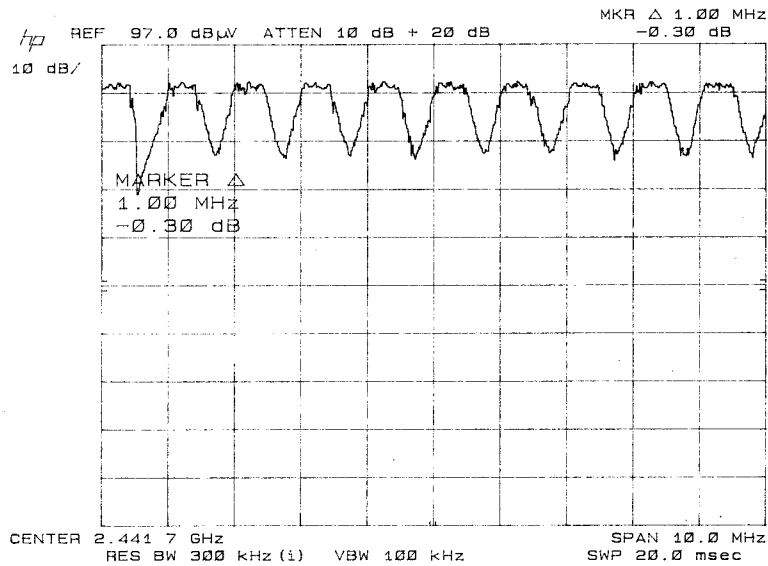

APPLICANT: ITRONIX
FCC ID: KBCIX100XUSIWLBT
REPORT #: I\ITRONIX\423AUT4\423AUT4TestReport.doc

TIMCO ENGINEERING INC.

849 NW State Road 45
Newberry, Florida 32669
http://www.timcoengr.com
888.472.2424 F 352.472.2030 email: tei@timcoengr.com

15.247(a)(1)(i): **Dwell Time of Hop:**

The swell time of any hopping frequency cannot be greater than 0.4 seconds in any 30 second period. The dwell time in 30 seconds is 600 useconds.

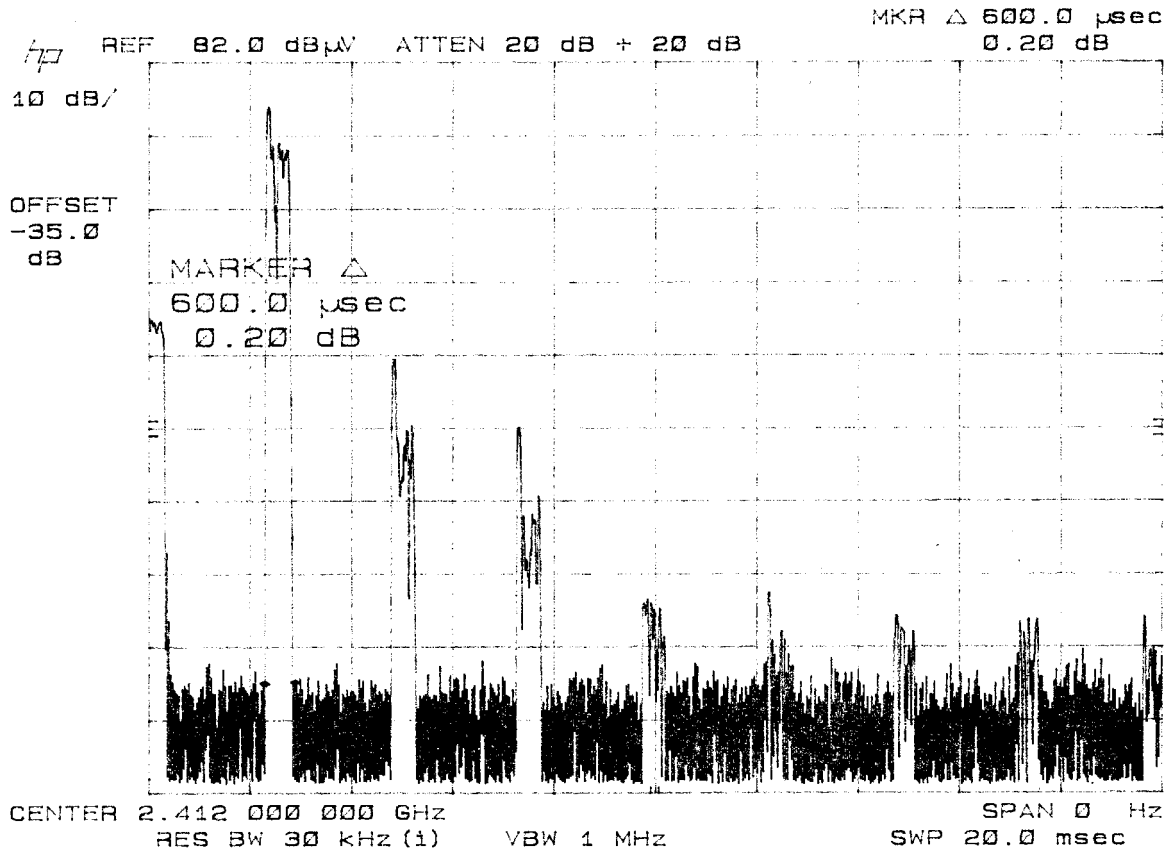

TIMCO ENGINEERING INC.

849 NW State Road 45
Newberry, Florida 32669
<http://www.timcoengr.com>
888.472.2424 F 352.472.2030 email: tei@timcoengr.com

- 15.247(b)(3): The antenna's gain is a negative number. This is described in the circuit description.
- 15.247(a)(1)(i): The maximum allowed 20 dB bandwidth of a hopping channel is 1 MHz. The 20 dB bandwidth measured was 850 kHz.

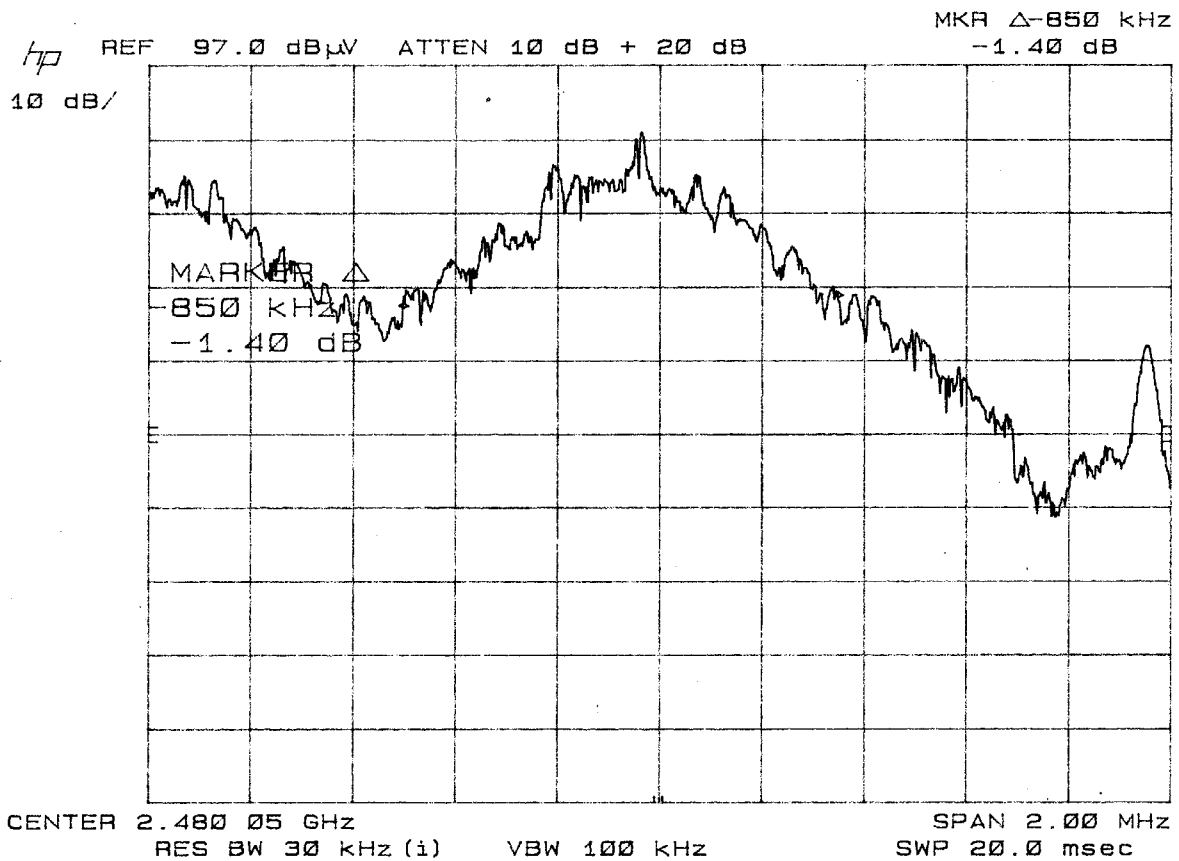

TIMCO ENGINEERING INC.

849 NW State Road 45
Newberry, Florida 32669
<http://www.timcoengr.com>
888.472.2424 F 352.472.2030 email: tei@timcoengr.com

NAME OF TEST: POWER OUTPUT

RULES PART NO.: 15.247(b) 1.0 Watt or +30 dBm
250 mW or 24 dBm for 24 dBi Gain Ant

MEASUREMENT: 3.5 dBm

15.247(c) **Method of Measuring RF Power output:**
The Peak power Sensor was connected in place of the antenna.

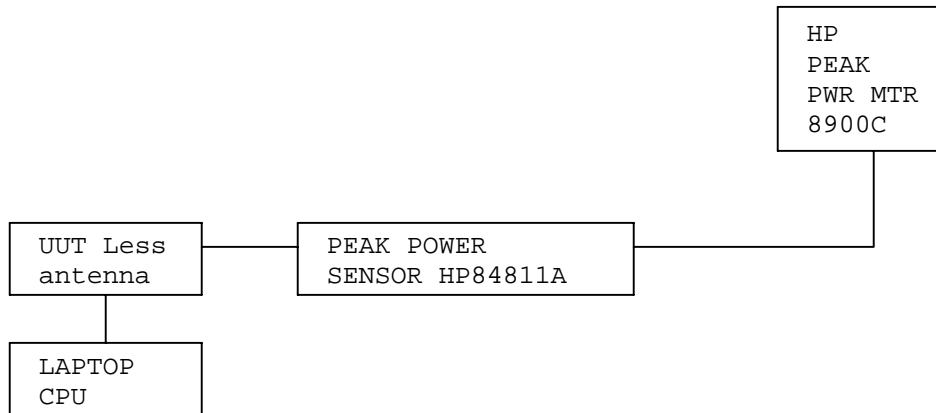

3 channels were measured and the worst case is reported here

TIMCO ENGINEERING INC.

849 NW State Road 45
Newberry, Florida 32669
<http://www.timcoengr.com>
888.472.2424 F 352.472.2030 email: tei@timcoengr.com

NAME OF TEST: SPURIOUS EMISSIONS AT ANTENNA TERMINALS

REQUIREMENTS: Emissions must be at least 20dB down from the highest emission level within the authorized band as measured with a 100 kHz RBW.

TEST DATA:

TF	EF	dB below carrier	TF	EF	dB below carrier
2402	2402	0.0	2441	2441	0.0
	2251	81.1		2288	81.1
	2274	77.5		4882	61.7
	2306	76.7		7323	63.6
	2326	72.6			
	4804	59.4			
	7206	64.7			

TF	EF	dB below carrier
2479	2479	0.0
	2324	73.2
	2556.6	71.2
	4958	58.8
	7437	107.7
	4804	58.7

15.247(c) Method of Measuring RF Conducted Spurious Emissions

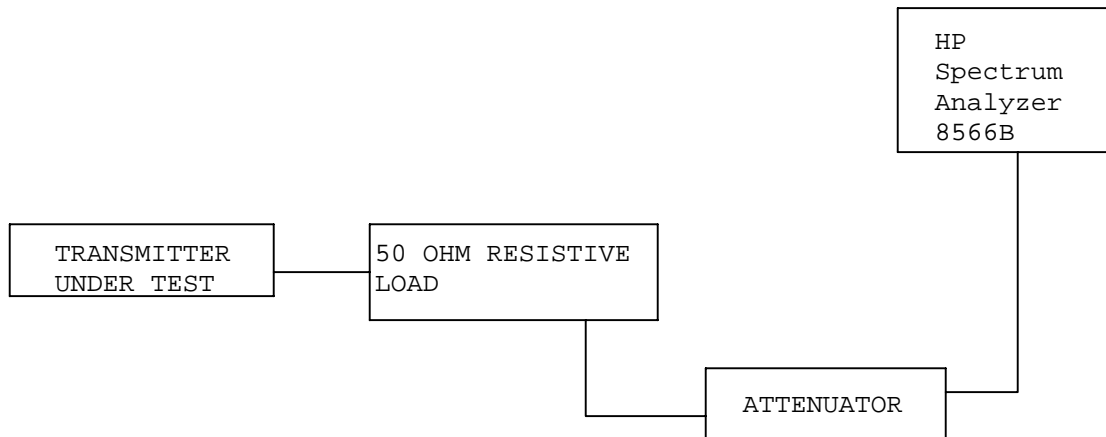

NOTE: THE SPECTRUM WAS SCANNED TO THE TENTH HARMONIC

APPLICANT: ITRONIX
FCC ID: KBCIX100XUSIWLBT
REPORT #: I\ITRONIX\423AUT4\423AUT4TestReport.doc

TIMCO ENGINEERING INC.

849 NW State Road 45
Newberry, Florida 32669
http://www.timcoengr.com
888.472.2424 F 352.472.2030 email: tei@timcoengr.com

15.247(c), 15.205 & 15.209(b) **Field strength of spurious emissions:**

REQUIREMENTS:

FIELD STRENGTH of Fundamental: 902-928MHz 2.4-2.4835GHz 127.38dBuV/m @3m	FIELD STRENGTH of Harmonics 127.37dBuV/m 54 dBuV/m @3m	S15.209 30 - 88 MHz 40 dBuV/m @3M 88 -216 MHz 43.5 216 -960 MHz 46 ABOVE 960 MHz 54dBuV/m
--	---	---

EMISSIONS RADIATED OUTSIDE OF THE SPECIFIED FREQUENCY BANDS, EXCEPT FOR HARMONICS, SHALL BE ATTENUATED BY AT LEAST 50 dB BELOW THE LEVEL OF THE FUNDAMENTAL OR TO THE GENERAL RADIATED EMISSION LIMITS IN 15.209, WHICHEVER IS THE LESSER ATTENUATION.

REQUIREMENTS: Emissions that fall in the restricted bands (15.205) must be less than 54dBuV/m otherwise the spurious and harmonics must be attenuated by at least 20dB.

TEST DATA:

Tuned Frequency MHz	Emission Frequency MHz	Meter Reading dBuV	Ant. Polarity	Coax Loss dB	Correction Factor dB	Field Strength dBuV/m	Margin dB
2,402.0	2,402.00	59.8	V	1.86	29.26	90.92	36.45
2,402.0	4,804.00R	10.3	V	2.64	33.97	46.91AV	7.09
2,441.0	2,322.00R	6.3	V	1.83	29.15	37.28AV	16.72
2,441.0	2,340.00R	6.3	V	1.84	29.18	37.32AV	16.68
2,441.0	2,441.00	63.0	V	1.88	29.32	94.20	33.17
2,441.0	2,543.00	6.8	V	1.92	29.49	38.21	15.79
2,441.0	2,603.00	10.2	V	1.94	29.63	41.77	12.23
2,441.0	2,724.60R	14.2	V	1.99	29.89	46.08AV	7.92
2,441.0	2,724.60R	27.0	V	1.99	29.89	58.88PK	15.12
2,441.0	2,730.00R	13.5	V	1.99	29.91	45.40AV	8.60
2,441.0	2,730.00R	28.5	V	1.99	29.91	60.40PK	13.60
2,441.0	2,735.00R	11.9	V	1.99	29.92	43.81AV	10.19
2,441.0	2,735.00R	24.8	V	1.99	29.92	56.71PK	17.29
2,441.0	4,882.00R	11.8	V	2.66	34.22	48.68AV	5.32
2,479.0	2,479.00	59.3	V	1.89	29.37	90.56	36.81
2,479.0	2,725.00R	11.3	V	1.99	29.90	43.19AV	10.81
2,479.0	2,725.00R	25.5	V	1.99	29.90	57.39PK	16.61
2,479.0	2,729.60R	13.2	V	1.99	29.91	45.10AV	8.90
2,479.0	2,729.60R	26.9	V	1.99	29.91	58.80PK	15.20
2,479.0	2,734.70R	11.3	V	1.99	29.92	43.21AV	10.79
2,479.0	2,734.70R	17.8	V	1.99	29.92	49.71PK	24.29
2,479.0	4,958.00R	12.5	V	2.69	34.47	49.66AV	4.34
2,543.0	2,340.00R	6.8	V	1.84	29.18	37.82AV	16.18

Harmonics were checked through the 10th harmonic

APPLICANT: ITRONIX
FCC ID: KBCIX100XUSIWLBT
REPORT #: I\ITRONIX\423AUT4\423AUT4TestReport.doc

TIMCO ENGINEERING INC.

849 NW State Road 45
Newberry, Florida 32669
<http://www.timcoengr.com>
888.472.2424 F 352.472.2030 email: tei@timcoengr.com

Method of Measuring Radiated Spurious Emissions

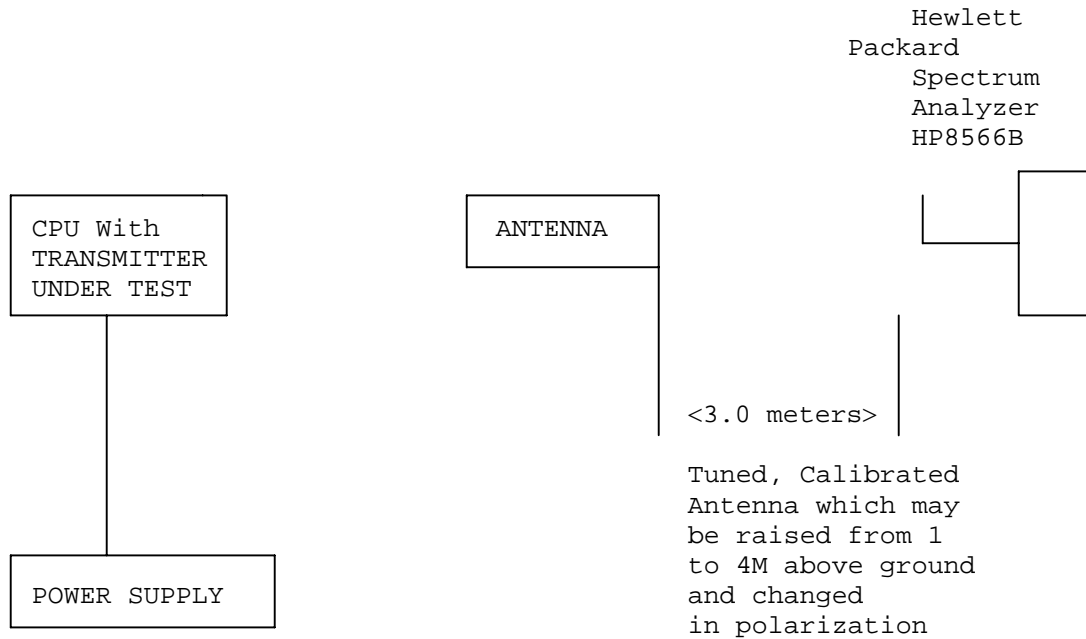

Equipment placed 80cm above ground on a rotatable platform.

METHOD OF MEASUREMENT: The procedure used was ANSI STANDARD C63.4-1992 & the FCC/OET Guidance on Measurements for Direct Sequence Spread Spectrum Systems - Public Notice 54797 Dated July 12, 1995. Measurements were made at the open field test site of TIMCO ENGINEERING INC. located at 849 N.W. State Road 45, Newberry, FL 32669.