



# FCC RF Test Report

**APPLICANT** : D-Link Co.  
**EQUIPMENT** : 4G LTE Router  
**BRAND NAME** : D-Link  
**MODEL NAME** : DWR-922  
**FCC ID** : KA2WR922C3  
**STANDARD** : FCC Part 15 Subpart C §15.247  
**CLASSIFICATION** : (DTS) Digital Transmission System

The product was received on Oct. 05, 2016 and testing was completed on Nov. 11, 2016. We, SPORTON INTERNATIONAL INC., would like to declare that the tested sample has been evaluated in accordance with the test procedures and has been in compliance with the applicable technical standards.

The test results in this report apply exclusively to the tested model / sample. Without written approval of SPORTON INTERNATIONAL INC., the test report shall not be reproduced except in full.

Reviewed by: Joseph Lin / Supervisor

Approved by: Jones Tsai / Manager



## **SPORTON INTERNATIONAL INC.**

**No. 52, Hwa Ya 1<sup>st</sup> Rd., Hwa Ya Technology Park, Kwei-Shan District, Tao Yuan City, Taiwan, R.O.C.**

SPORTON INTERNATIONAL INC.

TEL : 886-3-327-3456

FAX : 886-3-328-4978

FCC ID : KA2WR922C3

Page Number : 1 of 49

Report Issued Date : Dec. 07, 2016

Report Version : Rev. 01

Report Template No.: BU5-FR15CWL MA Version 1.3



# TABLE OF CONTENTS

**REVISION HISTORY ..... 3**

**SUMMARY OF TEST RESULT ..... 4**

**1 GENERAL DESCRIPTION ..... 5**

    1.1 Applicant ..... 5

    1.2 Manufacturer ..... 5

    1.3 Product Feature of Equipment Under Test ..... 5

    1.4 Product Specification of Equipment Under Test ..... 6

    1.5 Modification of EUT ..... 6

    1.6 Testing Location ..... 7

    1.7 Applicable Standards ..... 8

**2 TEST CONFIGURATION OF EQUIPMENT UNDER TEST ..... 9**

    2.1 Carrier Frequency and Channel ..... 9

    2.2 Test Mode ..... 10

    2.3 Connection Diagram of Test System ..... 11

    2.4 Support Unit used in test configuration and system ..... 12

    2.5 EUT Operation Test Setup ..... 12

    2.6 Measurement Results Explanation Example ..... 12

**3 TEST RESULT ..... 13**

    3.1 6dB and 99% Bandwidth Measurement ..... 13

    3.2 Peak Output Power Measurement ..... 15

    3.3 Power Spectral Density Measurement ..... 17

    3.4 Conducted Band Edges and Spurious Emission Measurement ..... 20

    3.5 Radiated Band Edges and Spurious Emission Measurement ..... 39

    3.6 AC Conducted Emission Measurement ..... 43

    3.7 Antenna Requirements ..... 47

**4 LIST OF MEASURING EQUIPMENT ..... 48**

**5 UNCERTAINTY OF EVALUATION ..... 49**

**APPENDIX A. CONDUCTED TEST RESULTS**

**APPENDIX B. RADIATED SPURIOUS EMISSION**

**APPENDIX C. RADIATED SPURIOUS EMISSION PLOTS**

**APPENDIX D. DUTY CYCLE PLOTS**

**APPENDIX E. SETUP PHOTOGRAPHS**





### SUMMARY OF TEST RESULT

Report Section	FCC Rule	Description	Limit	Result	Remark
3.1	15.247(a)(2)	6dB Bandwidth	$\geq 0.5\text{MHz}$	Pass	-
3.1	-	99% Bandwidth	-	Pass	-
3.2	15.247(b)	Power Output Measurement	$\leq 30\text{dBm}$	Pass	-
3.3	15.247(e)	Power Spectral Density	$\leq 8\text{dBm}/3\text{kHz}$	Pass	-
3.4	15.247(d)	Conducted Band Edges	$\leq 20\text{dBc}$	Pass	-
		Conducted Spurious Emission		Pass	-
3.5	15.247(d)	Radiated Band Edges and Radiated Spurious Emission	15.209(a) & 15.247(d)	Pass	Under limit 0.54 dB at 7386.000 MHz
3.6	15.207	AC Conducted Emission	15.207(a)	Pass	Under limit 5.30 dB at 0.286 MHz
3.7	15.203 & 15.247(b)	Antenna Requirement	N/A	Pass	-



# 1 General Description

## 1.1 Applicant

**D-Link Co.**

No. 289, Sinhu 3rd Rd, Neihu District Taipei City 114 Taiwan

## 1.2 Manufacturer

**Advance Multimedia Internet Technology Inc.**

No. 28, Lane 31, Sec. 1, Huandong Rd., Sinshih District, Tainan City 74146, Taiwan (R.O.C.)

## 1.3 Product Feature of Equipment Under Test

Product Feature	
<b>Equipment</b>	4G LTE Router
<b>Brand Name</b>	D-Link
<b>Model Name</b>	DWR-922
<b>FCC ID</b>	KA2WR922C3
<b>EUT supports Radios application</b>	GSM/EGPRS/WCDMA/HSPA/LTE WLAN 11b/g/n HT20/HT40
<b>HW Version</b>	C3
<b>EUT Stage</b>	Production Unit

**Remark:** The above EUT's information was declared by manufacturer. Please refer to the specifications or user's manual for more detailed description.



### 1.4 Product Specification of Equipment Under Test

Standards-related Product Specification										
<b>Tx/Rx Channel Frequency Range</b>	2412 MHz ~ 2462 MHz									
<b>Maximum (Peak) Output Power to antenna</b>	<p><b>&lt;Ant. 1&gt;</b>            802.11b : 17.60 dBm (0.0575 W)            802.11g : 23.04 dBm (0.2014 W)            802.11n HT20 : 22.25 dBm (0.1679 W)            802.11n HT40 : 22.08 dBm (0.1614 W)</p> <p><b>&lt;Ant. 2&gt;</b>            802.11b : 17.55 dBm (0.0569 W)            802.11g : 22.50 dBm (0.1778 W)            802.11n HT20 : 23.27 dBm (0.2123 W)            802.11n HT40 : 23.30 dBm (0.2138 W)</p> <p><b>MIMO &lt;Ant. 1 + 2&gt;</b>            802.11n HT20 : 26.39 dBm (0.4355 W)            802.11n HT40 : 26.45 dBm (0.4416 W)</p>									
<b>99% Occupied Bandwidth</b>	802.11b : 12.40MHz 802.11g : 18.30MHz 802.11n HT20 : 18.60MHz 802.11n HT40 : 37.10MHz									
<b>Antenna Type / Gain</b>	<p><b>&lt;Ant 1&gt;</b>            PIFA Antenna type with gain 3.80 dBi</p> <p><b>&lt;Ant 2&gt;</b>            PIFA Antenna type with gain 3.80 dBi</p>									
<b>Type of Modulation</b>	802.11b : DSSS (DBPSK / DQPSK / CCK) 802.11g/n : OFDM (BPSK / QPSK / 16QAM / 64QAM)									
<b>Antenna Function for Transmitter</b>	<table border="1"> <thead> <tr> <th></th> <th>Ant. 1</th> <th>Ant. 2</th> </tr> </thead> <tbody> <tr> <td>802.11 b/g/n</td> <td>V</td> <td>V</td> </tr> <tr> <td>802.11 n MIMO</td> <td>V</td> <td>V</td> </tr> </tbody> </table>		Ant. 1	Ant. 2	802.11 b/g/n	V	V	802.11 n MIMO	V	V
	Ant. 1	Ant. 2								
802.11 b/g/n	V	V								
802.11 n MIMO	V	V								

Note: MIMO Ant. 1+2 is a calculated result from sum of the power MIMO Ant. 1 and MIMO Ant. 2.

### 1.5 Modification of EUT

No modifications are made to the EUT during all test items.



### 1.6 Testing Location

Sporton Lab is accredited to ISO 17025 by Taiwan Accreditation Foundation (TAF code : 1190) and the FCC designation No. TW1022 under the FCC 2.948(e) by Mutual Recognition Agreement (MRA) in FCC Test.

<b>Test Site</b>	SPORTON INTERNATIONAL INC.	
<b>Test Site Location</b>	No. 52, Hwa Ya 1 <sup>st</sup> Rd., Hwa Ya Technology Park, Kwei-Shan District, Tao Yuan City, Taiwan, R.O.C. TEL: +886-3-327-3456 FAX: +886-3-328-4978	
<b>Test Site No.</b>	<b>Sporton Site No.</b>	
	TH05-HY	CO05-HY

**Note:** The test site complies with ANSI C63.4 2014 requirement.

<b>Test Site</b>	SPORTON INTERNATIONAL INC.	
<b>Test Site Location</b>	No.58, Aly. 75, Ln. 564, Wenhua 3rd Rd. Guishan Dist, Taoyuan City, Taiwan (R.O.C.) TEL: +886-3-327-0868 FAX: +886-3-327-0855	
<b>Test Site No.</b>	<b>Sporton Site No.</b>	
	03CH12-HY	

**Note:** The test site complies with ANSI C63.4 2014 requirement.



## 1.7 Applicable Standards

According to the specifications of the manufacturer, the EUT must comply with the requirements of the following standards:

- ♦ FCC Part 15 Subpart C §15.247
- ♦ FCC KDB Publication No. 558074 D01 DTS Meas. Guidance v03r05
- ♦ FCC KDB 662911 D01 Multiple Transmitter Output v02r01.
- ♦ ANSI C63.10-2013

### **Remark:**

1. All test items were verified and recorded according to the standards and without any deviation during the test.
2. This EUT has also been tested and complied with the requirements of FCC Part 15, Subpart B, recorded in a separate test report.





## 2 Test Configuration of Equipment Under Test

The EUT has been associated with peripherals and configuration operated in a manner tended to maximize its emission characteristics in a typical application. Frequency range investigated: conducted emission (150 kHz to 30 MHz) and radiated emission (9 kHz to the 10th harmonic of the highest fundamental frequency or to 40 GHz, whichever is lower).

### 2.1 Carrier Frequency and Channel

Frequency Band	Channel	Freq. (MHz)	Channel	Freq. (MHz)
2400-2483.5 MHz	1	2412	7	2442
	2	2417	8	2447
	3	2422	9	2452
	4	2427	10	2457
	5	2432	11	2462
	6	2437		



## 2.2 Test Mode

Final test mode of conducted test items and radiated spurious emissions are considering the modulation and worse data rates as below table.

### Single Antenna

Modulation	Data Rate
802.11b	1 Mbps
802.11g	6 Mbps
802.11n HT20	MCS0
802.11n HT40	MCS0

### MIMO Antenna

Modulation	Data Rate
802.11n HT20	MCS8
802.11n HT40	MCS8

Test Cases	
AC Conducted Emission	Mode 1 : GSM850 (GPRS class 8) Idle + WLAN (2.4GHz) Link + LAN Link + WAN Link + Adapter

## 2.3 Connection Diagram of Test System

<WLAN Tx Mode>

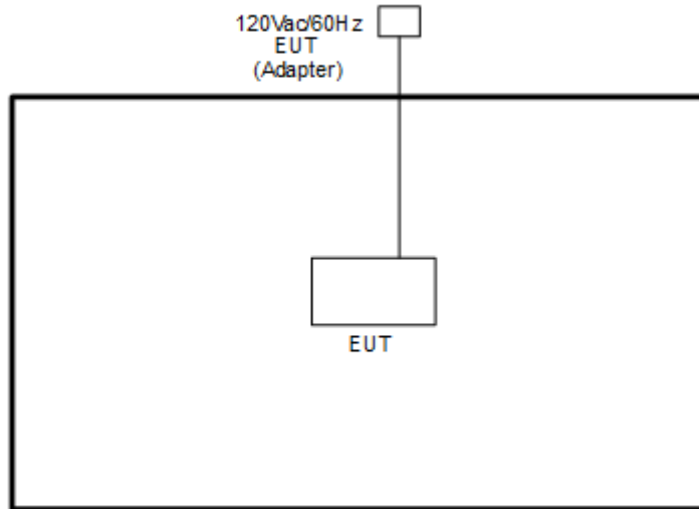

<AC Conducted Emission Mode>

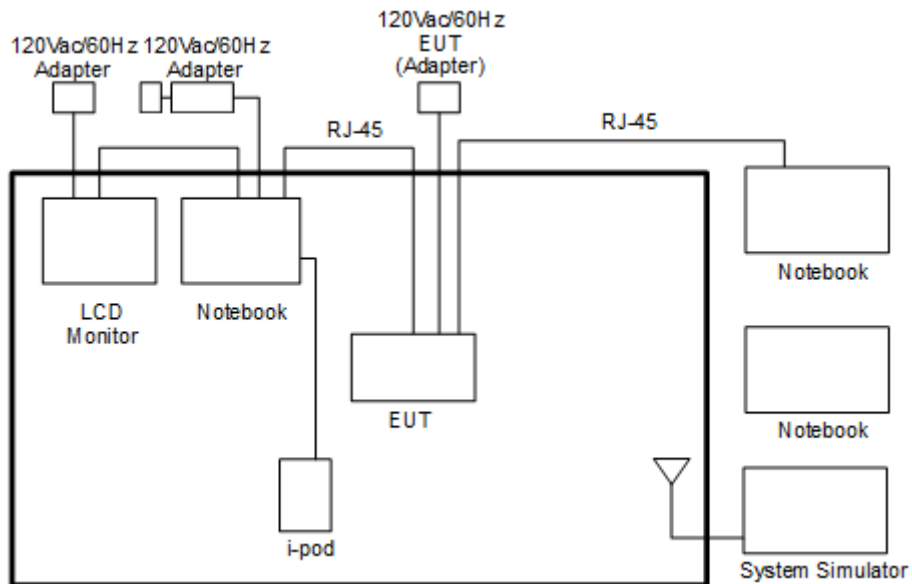



### 2.4 Support Unit used in test configuration and system

Item	Equipment	Trade Name	Model Name	FCC ID	Data Cable	Power Cord
1.	System Simulator	Anritsu	MT8820C	N/A	N/A	Unshielded, 1.8 m
2.	Notebook	DELL	P20G	FCC DoC/ Contains FCC ID: QDS-BRCM1051	N/A	AC I/P: Unshielded, 1.2 m DC O/P: Shielded, 1.8 m
3.	Notebook	DELL	Latitude E6320	FCC DoC/ Contains FCC ID: QDS-BRCM1054	N/A	AC I/P: Unshielded, 1.2 m DC O/P: Shielded, 1.8 m
4.	LCD Monitor	DELL	U2410	FCC DoC	Shielded, 1.6 m	Unshielded, 1.8 m
5.	iPod	Apple	A1285	FCC DoC	Shielded, 1.0 m	N/A

### 2.5 EUT Operation Test Setup

For WLAN function, programmed RF utility, “MT7620QAled in the notebook make the EUT provide functions like channel selection and power level for continuous transmitting and receiving signals.

### 2.6 Measurement Results Explanation Example

For all conducted test items:

The offset level is set in the spectrum analyzer to compensate the RF cable loss and attenuator factor between EUT conducted output port and spectrum analyzer. With the offset compensation, the spectrum analyzer reading level is exactly the EUT RF output level.

Example:

The spectrum analyzer offset is derived from RF cable loss and attenuator factor.

$$Offset = RF\ cable\ loss + attenuator\ factor.$$

Following shows an offset computation example with cable loss 4.2 dB and 10dB attenuator.

$$Offset(dB) = RF\ cable\ loss(dB) + attenuator\ factor(dB).$$

$$= 4.2 + 10 = 14.2\ (dB)$$

### 3 Test Result

#### 3.1 6dB and 99% Bandwidth Measurement

##### 3.1.1 Limit of 6dB and 99% Bandwidth

The minimum 6 dB bandwidth shall be at least 500 kHz.

##### 3.1.2 Measuring Instruments

The measuring equipment is listed in the section 4 of this test report.

##### 3.1.3 Test Procedures

1. The testing follows FCC KDB Publication No. 558074 DTS D01 Meas. Guidance v03r05.
2. The RF output of EUT was connected to the spectrum analyzer by RF cable and attenuator. The path loss was compensated to the results for each measurement.
3. Set to the maximum power setting and enable the EUT transmit continuously.
4. Make the measurement with the spectrum analyzer's resolution bandwidth (RBW) = 100 kHz. Set the Video bandwidth (VBW) = 300 kHz. In order to make an accurate measurement. The 6 dB bandwidth must be greater than 500 kHz.
5. For 99% Bandwidth Measurement, the spectrum analyzer's resolution bandwidth (RBW) = 1MHz and set the Video bandwidth (VBW) = 3MHz.
6. Measure and record the results in the test report.

##### 3.1.4 Test Setup





### 3.1.5 Test Result of 6dB and 99% Occupied Bandwidth

Please refer to Appendix A.

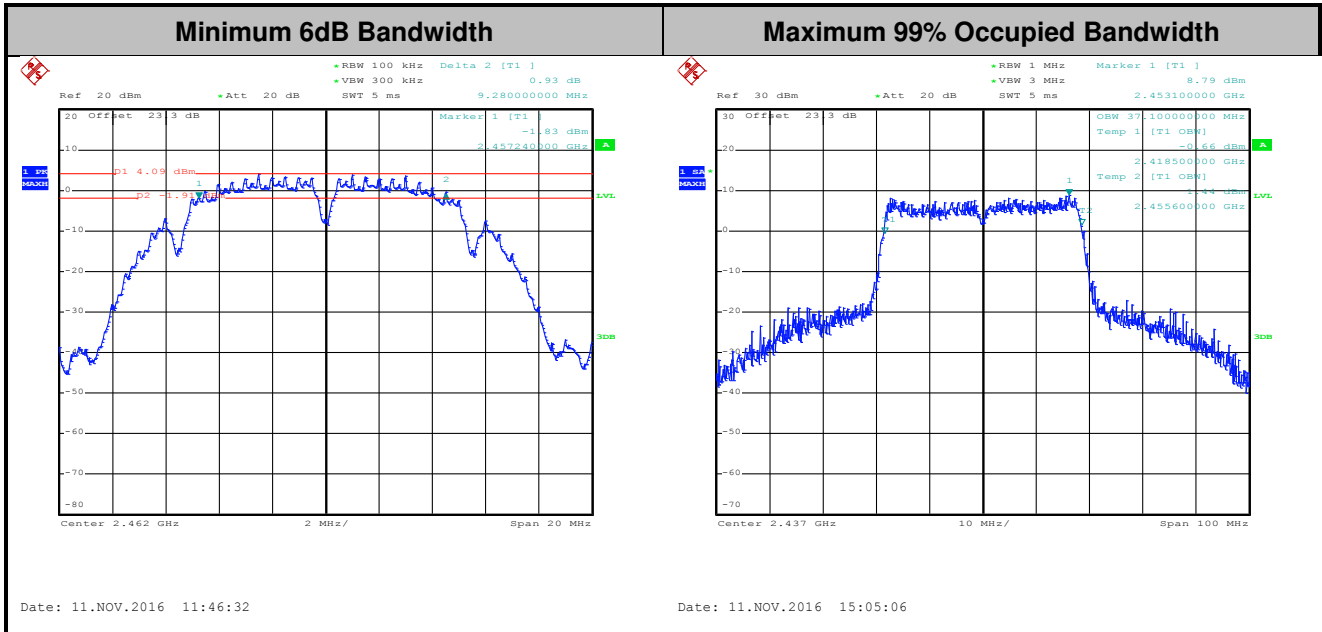

**Note:** The occupied channel bandwidth is maintained within the band of operation for all of the modulations.

## 3.2 Peak Output Power Measurement

### 3.2.1 Limit of Peak Output Power

For systems using digital modulation in the 2400-2483.5MHz, the limit for peak output power is 30dBm. If transmitting antenna with directional gain greater than 6dBi is used, the peak output power from the intentional radiator shall be reduced below the above stated value by the amount in dB that the directional gain of the antenna exceeds 6 dBi. In case of point-to-point operation, the limit has to be reduced by 1dB for every 3dB that the directional gain of the antenna exceeds 6dBi.

### 3.2.2 Measuring Instruments

The measuring equipment is listed in the section 4 of this test report.

### 3.2.3 Test Procedures

1. The testing follows the Measurement Procedure of FCC KDB No. 558074 DTS D01 Meas. Guidance v03r05 section 9.1.2 PKPM1 Peak power meter method.
2. The RF output of EUT was connected to the power meter by RF cable and attenuator. The path loss was compensated to the results for each measurement.
3. Set to the maximum power setting and enable the EUT transmit continuously.
4. Measure the conducted output power and record the results in the test report.
5. For MIMO mode, calculation method follows FCC KDB 662911 D01 Multiple Transmitter Output v02r01.

### 3.2.4 Test Setup

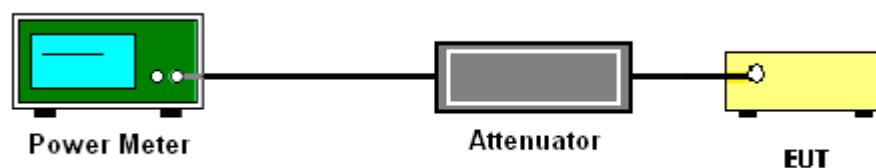



### **3.2.5 Test Result of Peak Output Power**

Please refer to Appendix A.

### **3.2.6 Test Result of Average output Power (Reporting Only)**

Please refer to Appendix A





### 3.3 Power Spectral Density Measurement

#### 3.3.1 Limit of Power Spectral Density

The peak power spectral density shall not be greater than 8dBm in any 3kHz band at any time interval of continuous transmission.

#### 3.3.2 Measuring Instruments

The measuring equipment is listed in the section 4 of this test report.

#### 3.3.3 Test Procedures

1. The testing follows Measurement Procedure 10.2 Method PKPSD of FCC KDB Publication No. 558074 D01 DTS Meas. Guidance v03r05.
2. The RF output of EUT was connected to the spectrum analyzer by RF cable and attenuator. The path loss was compensated to the results for each measurement.
3. Set to the maximum power setting and enable the EUT transmit continuously.
4. Make the measurement with the spectrum analyzer's resolution bandwidth (RBW) = 3 kHz. Video bandwidth VBW = 10 kHz In order to make an accurate measurement, set the span to 1.5 times DTS Channel Bandwidth. (6dB BW)
5. Detector = peak, Sweep time = auto couple, Trace mode = max hold, Allow trace to fully stabilize. Use the peak marker function to determine the maximum power level.
6. Measure and record the results in the test report.
7. For MIMO mode, calculation method follows FCC KDB 662911 D01 Multiple Transmitter Output v02r01.

If measurements performed using method (2) plus  $10 \log(N)$  exceeds the emission limit, the test should choose method (1) before declaring that the device fails the emission limit.

Method (1): Measure and sum the spectra across the outputs.

The total final Power Spectral Density is from a device with 2 transmitter outputs. The spectrum measurements of the individual outputs are all performed with the same span and number of points, the spectrum value in the first spectral bin of output 1 is summed with that in the first spectral bin of output 2 to obtain the value for the first frequency bin of the summed spectrum.

Method (2): Measure and add  $10 \log(N)$  dB, where N is the number of outputs. (N=2)

### 3.3.4 Test Setup

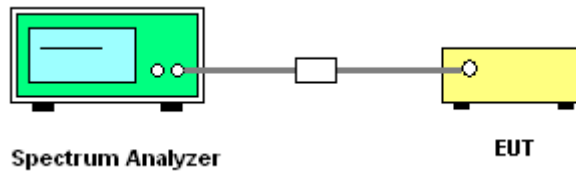

### 3.3.5 Test Result of Power Spectral Density

Please refer to Appendix A.

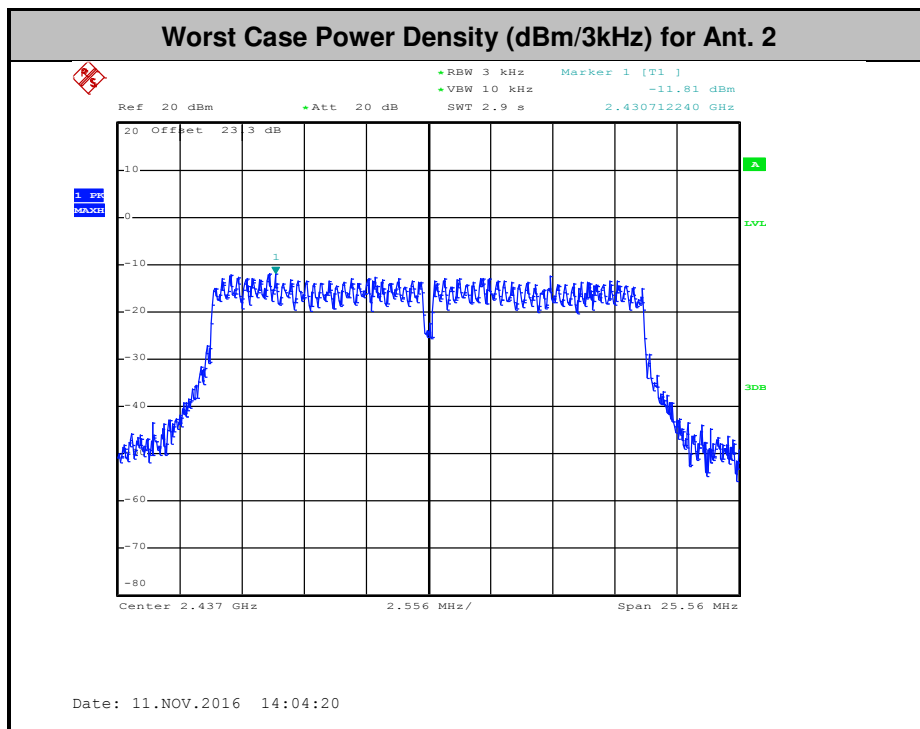
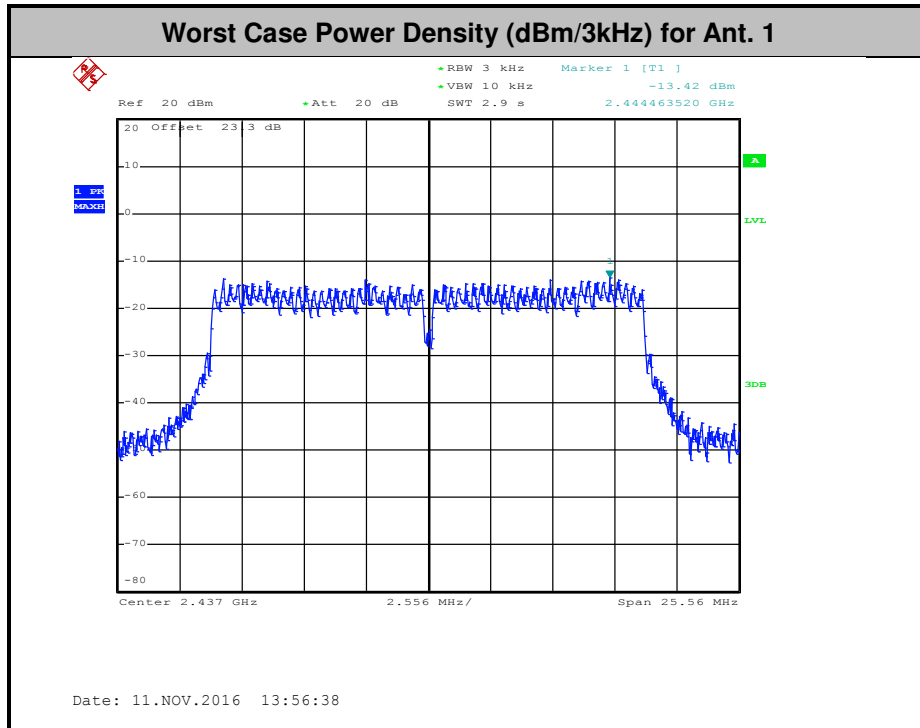

## 3.4 Conducted Band Edges and Spurious Emission Measurement

### 3.4.1 Limit of Conducted Band Edges and Spurious Emission Measurement

In any 100 kHz bandwidth outside of the authorized frequency band, the emissions which fall in the non-restricted bands shall be attenuated at least 20 dB / 30dB relative to the maximum PSD level in 100 kHz by RF conducted measurement and radiated emissions which fall in the restricted bands, as defined in Section 15.205(a), must also comply with the radiated emission limits specified in Section 15.209(a).

### 3.4.2 Measuring Instruments

The measuring equipment is listed in the section 4 of this test report.

### 3.4.3 Test Procedures

1. The testing follows FCC KDB Publication No. 558074 D01 DTS Meas. Guidance v03r05.
2. The RF output of EUT was connected to the spectrum analyzer by RF cable and attenuator. The path loss was compensated to the results for each measurement.
3. Set to the maximum power setting and enable the EUT transmit continuously.
4. Set RBW = 100 kHz, VBW=300 kHz, Peak Detector. Unwanted Emissions measured in any 100 kHz bandwidth outside of the authorized frequency band shall be attenuated by at least 20 dB relative to the maximum in-band peak PSD level in 100 kHz when maximum peak conducted output power procedure is used. If the transmitter complies with the conducted power limits based on the use of RMS averaging over a time interval, the attenuation required under this paragraph shall be 30 dB instead of 20 dB per 15.247(d).
5. Measure and record the results in the test report.
6. The RF fundamental frequency should be excluded against the limit line in the operating frequency band.

### 3.4.4 Test Setup

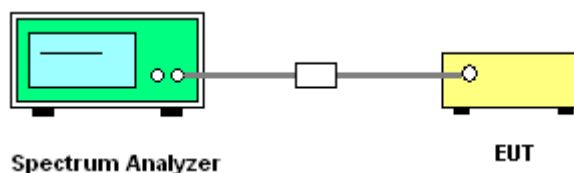



### 3.4.5 Test Result of Conducted Band Edges and Spurious Emission

Number of TX = 1, Ant. 1 (Measured)

Number of TX	1	Ant. :	1
Test Mode :	802.11b	Temperature :	21~25°C
Test Band :	2.4GHz Low	Relative Humidity :	51~54%
Test Channel :	01	Test Engineer :	Aking Chang and Tommy Lee

#### WLAN 802.11b Channel 01

##### 100kHz PSD reference Level

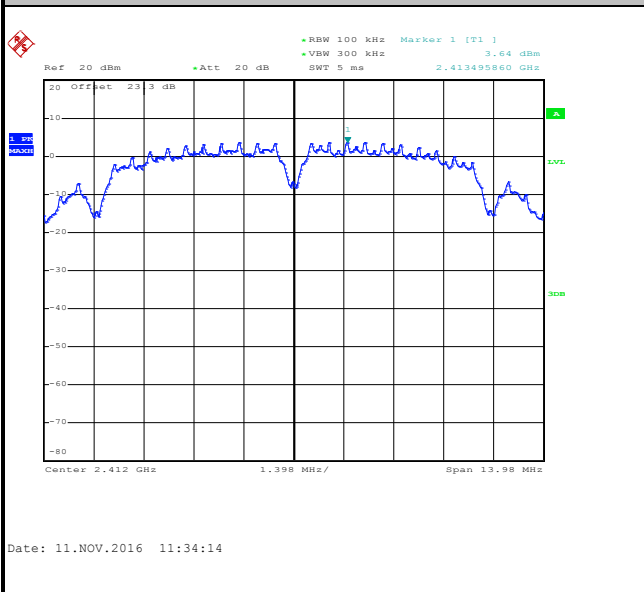

##### Low Channel Plot

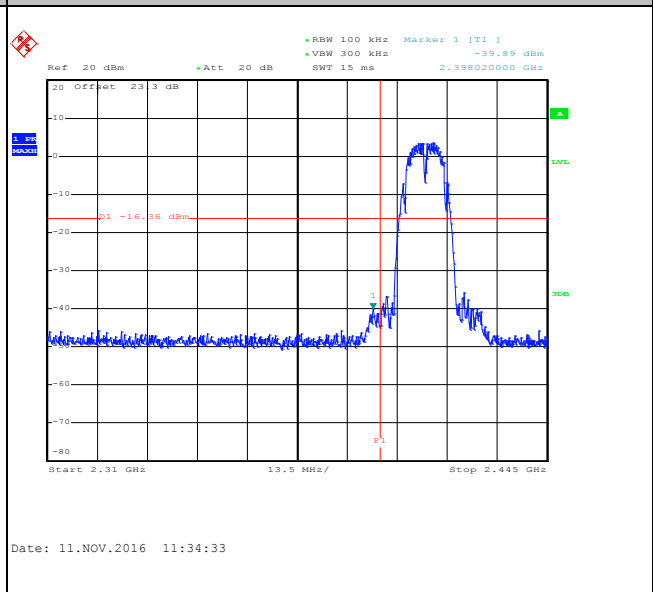

##### Spurious Emission 30MHz~3GHz

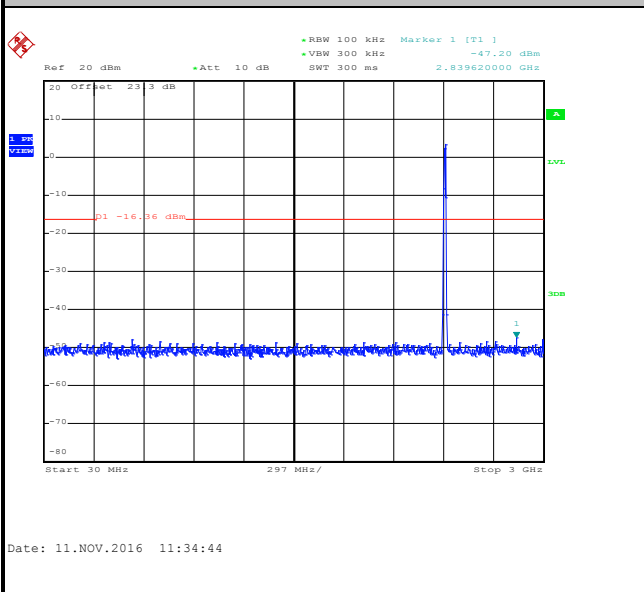

##### Spurious Emission 2GHz~25GHz

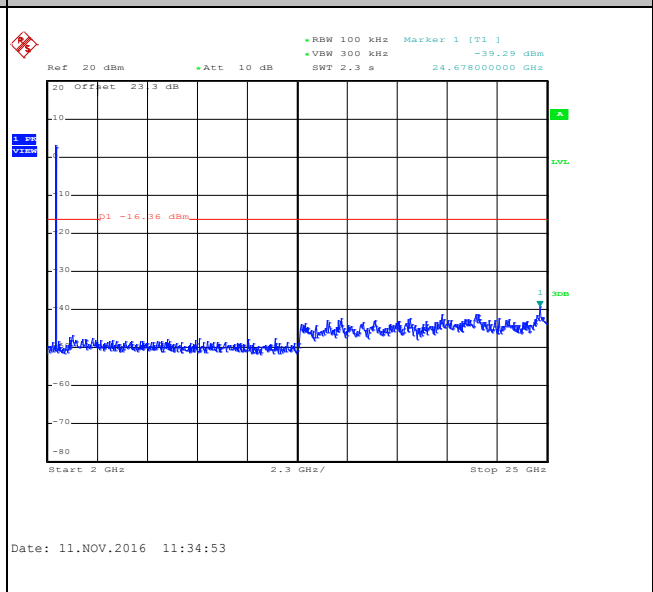



Number of TX :	1	Ant. :	1
Test Mode :	802.11b	Temperature :	21~25°C
Test Band :	2.4GHz Mid	Relative Humidity :	51~54%
Test Channel :	06	Test Engineer :	Aking Chang and Tommy Lee

WLAN 802.11b Channel 06

100kHz PSD reference Level

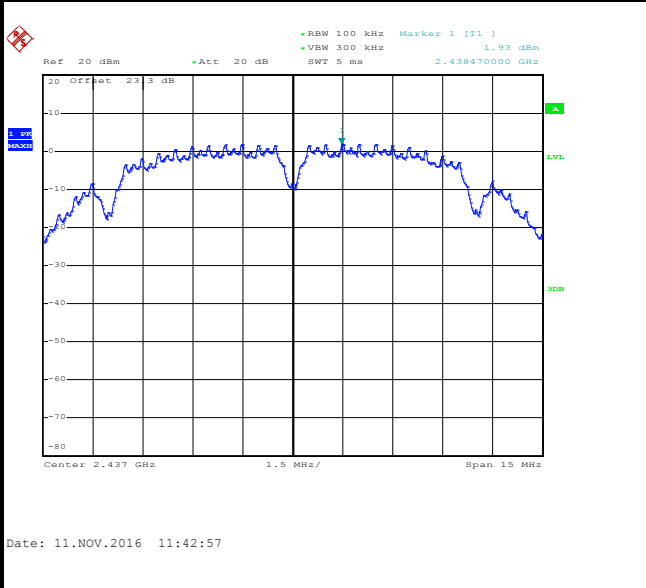

Spurious Emission 30MHz~3GHz

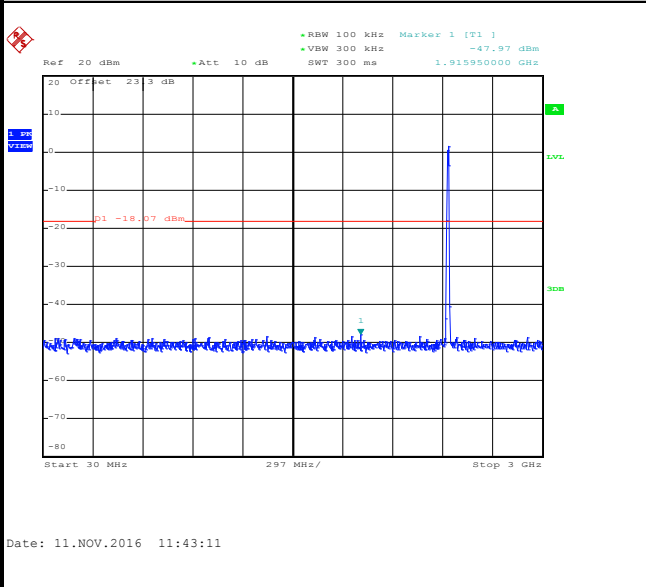

Spurious Emission 2GHz~25GHz

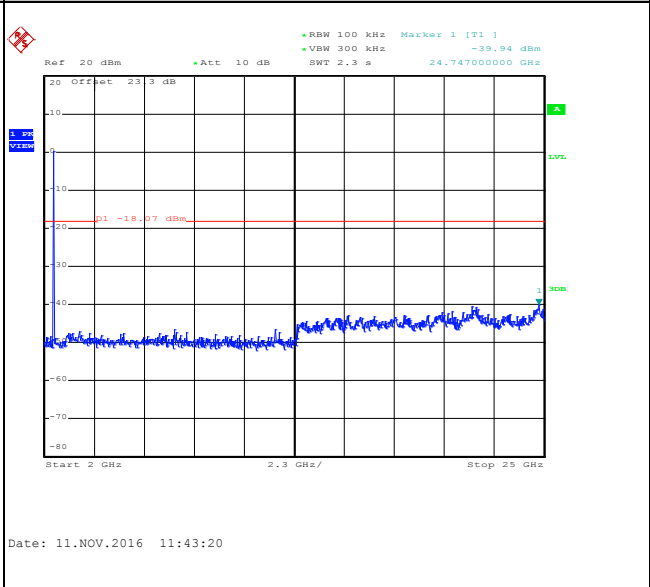



Number of TX :	1	Ant. :	1
Test Mode :	802.11b	Temperature :	21~25°C
Test Band :	2.4GHz High	Relative Humidity :	51~54%
Test Channel :	11	Test Engineer :	Aking Chang and Tommy Lee

WLAN 802.11b Channel 11

100kHz PSD reference Level

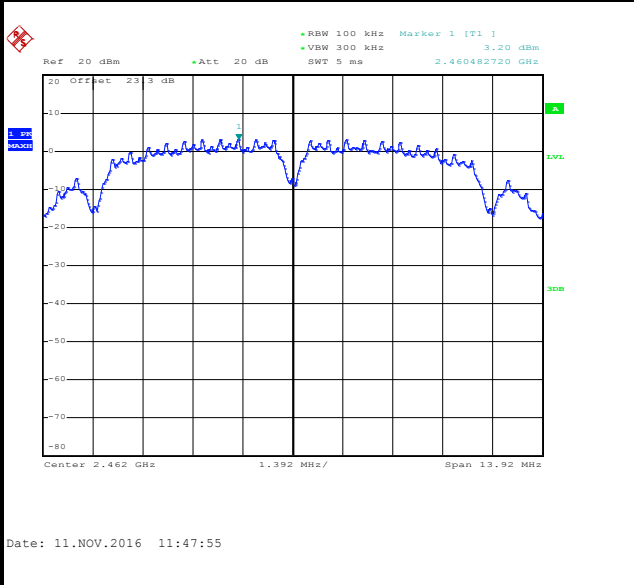

High Channel Plot

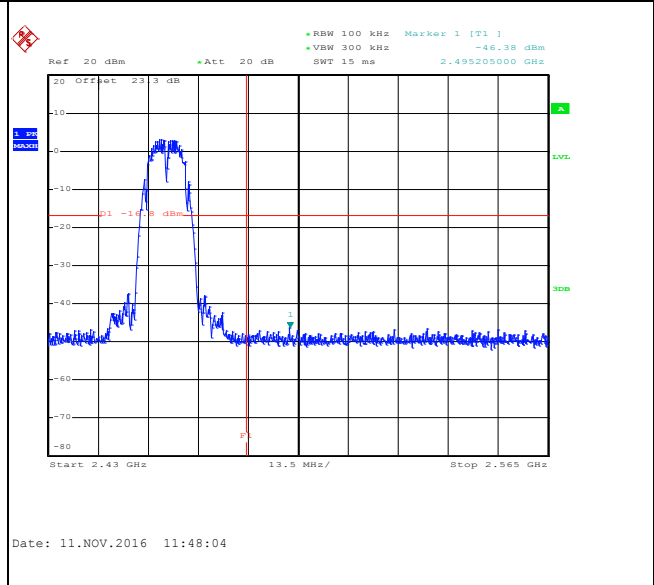

Spurious Emission 30MHz~3GHz

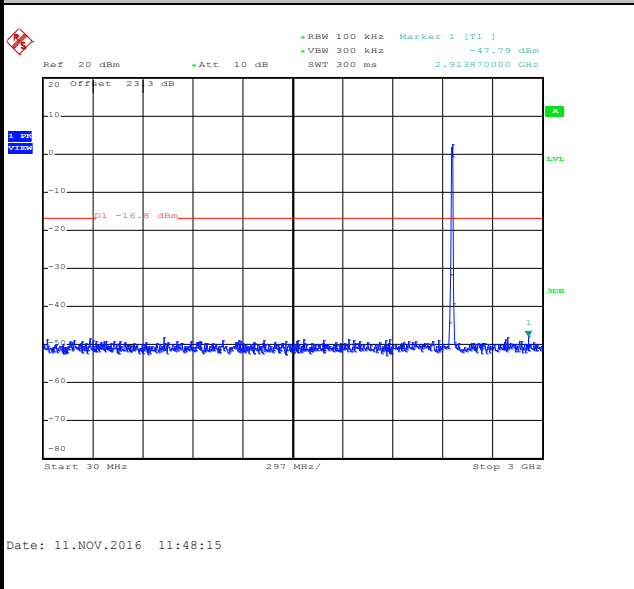

Spurious Emission 2GHz~25GHz

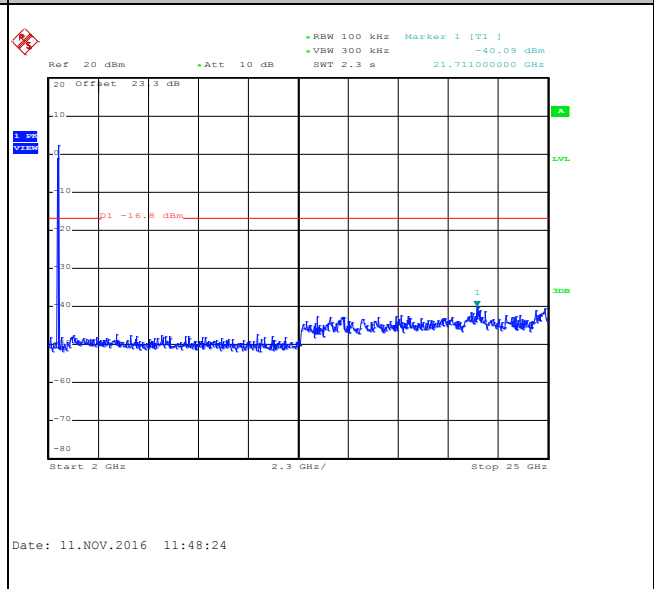



Number of TX :	1	Ant. :	1
Test Mode :	802.11g	Temperature :	21~25°C
Test Band :	2.4GHz Low	Relative Humidity :	51~54%
Test Channel :	01	Test Engineer :	Aking Chang and Tommy Lee

WLAN 802.11g Channel 01

100kHz PSD reference Level

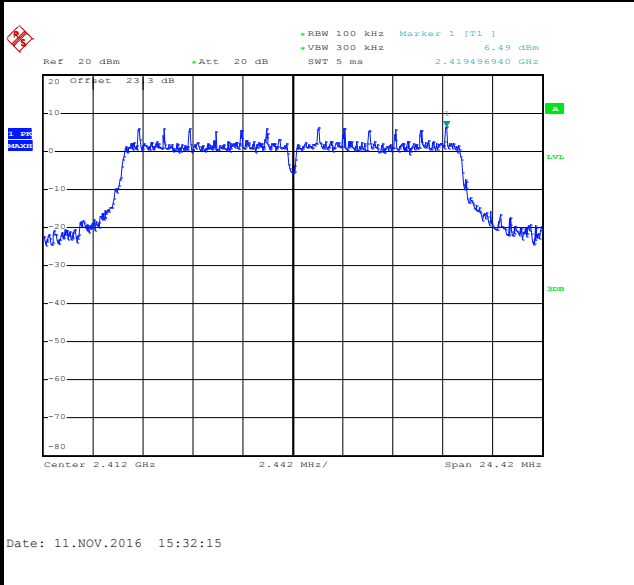

Low Channel Plot

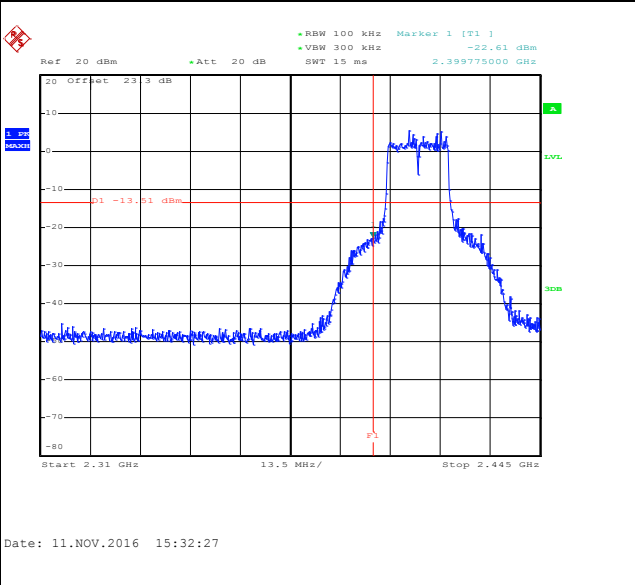

Spurious Emission 30MHz~3GHz

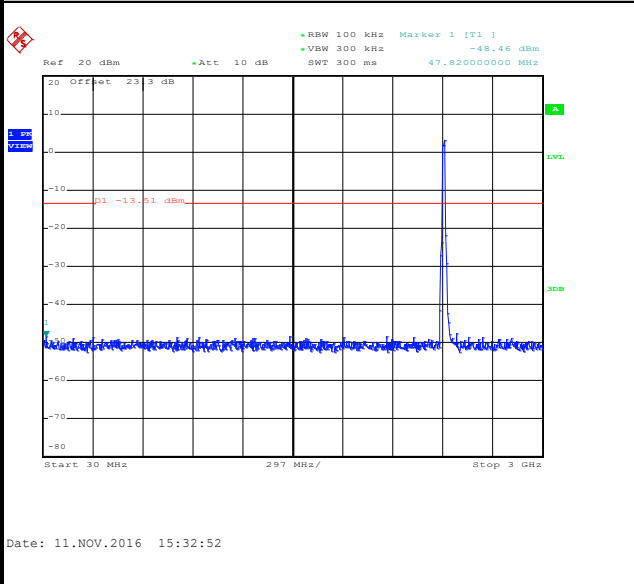

Spurious Emission 2GHz~25GHz

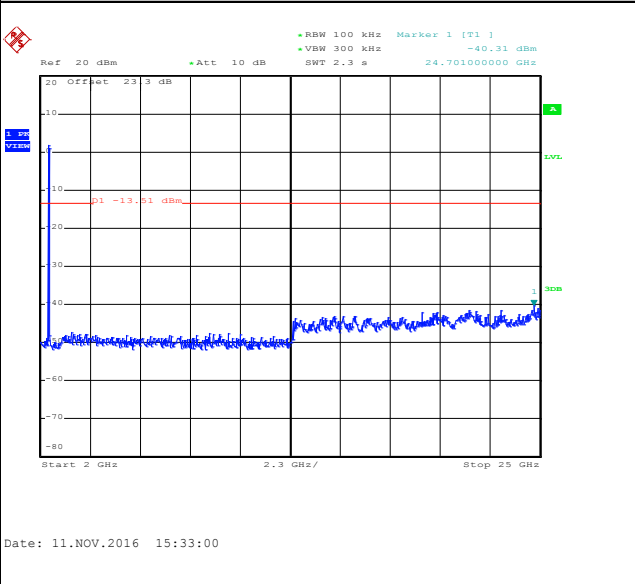





Number of TX :	1	Ant. :	1
Test Mode :	802.11g	Temperature :	21~25°C
Test Band :	2.4GHz Mid	Relative Humidity :	51~54%
Test Channel :	06	Test Engineer :	Aking Chang and Tommy Lee

WLAN 802.11g Channel 06

100kHz PSD reference Level

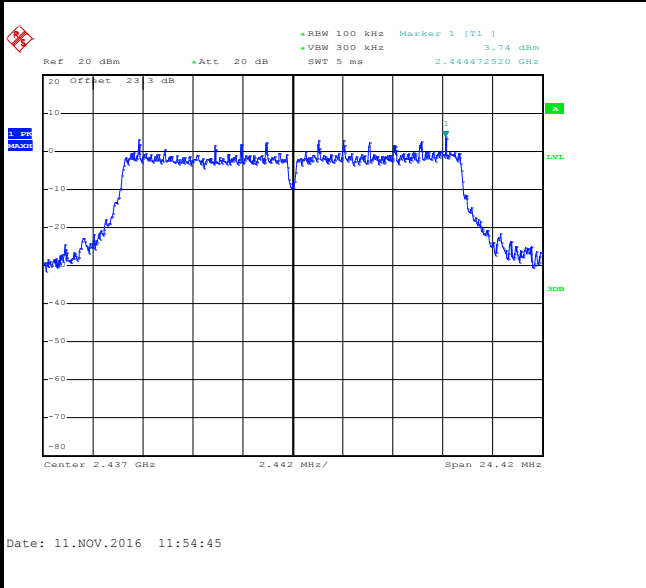

Spurious Emission 30MHz~3GHz

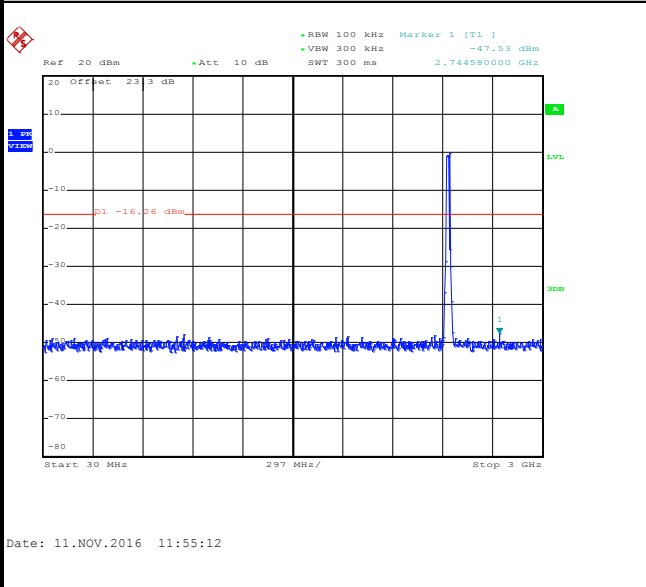

Spurious Emission 2GHz~25GHz

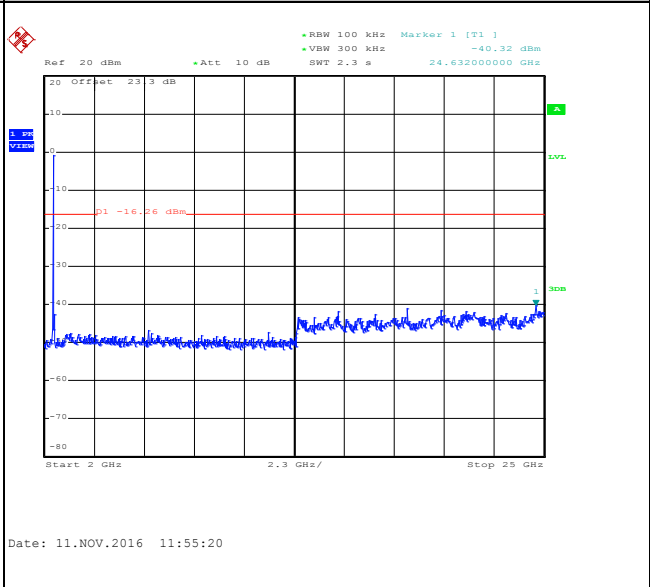



Number of TX :	1	Ant. :	1
Test Mode :	802.11g	Temperature :	21~25°C
Test Band :	2.4GHz High	Relative Humidity :	51~54%
Test Channel :	11	Test Engineer :	Aking Chang and Tommy Lee

WLAN 802.11g Channel 11

100kHz PSD reference Level

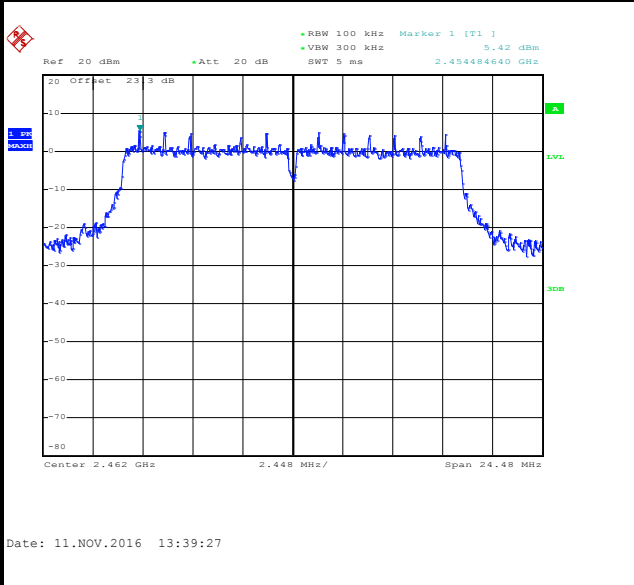

High Channel Plot

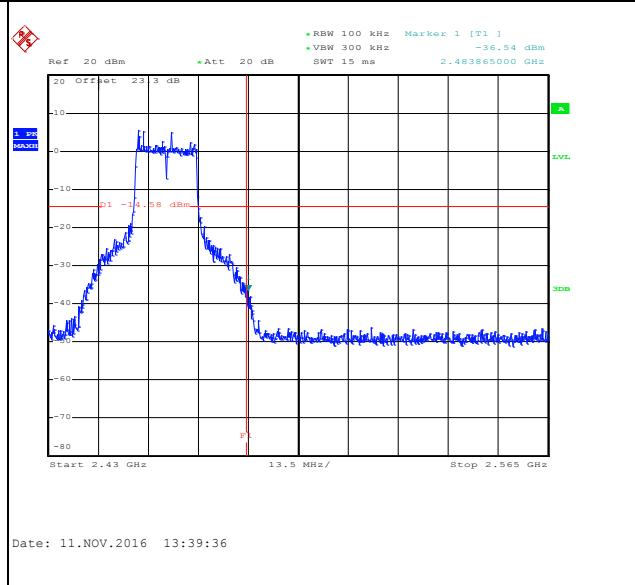

Spurious Emission 30MHz~3GHz

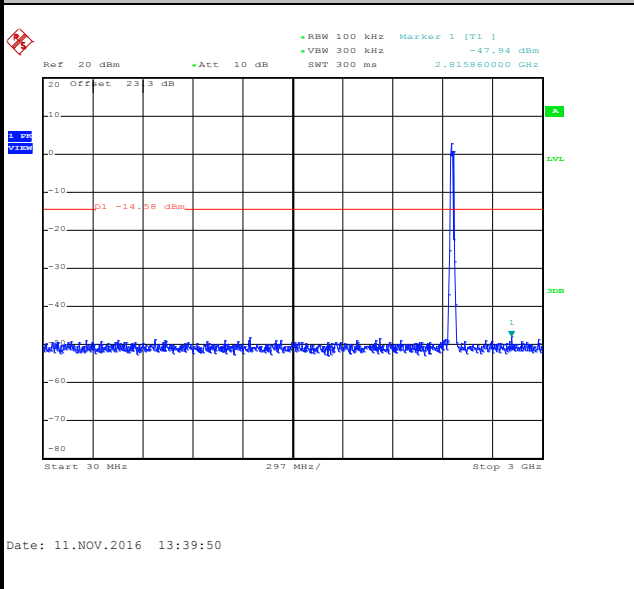

Spurious Emission 2GHz~25GHz

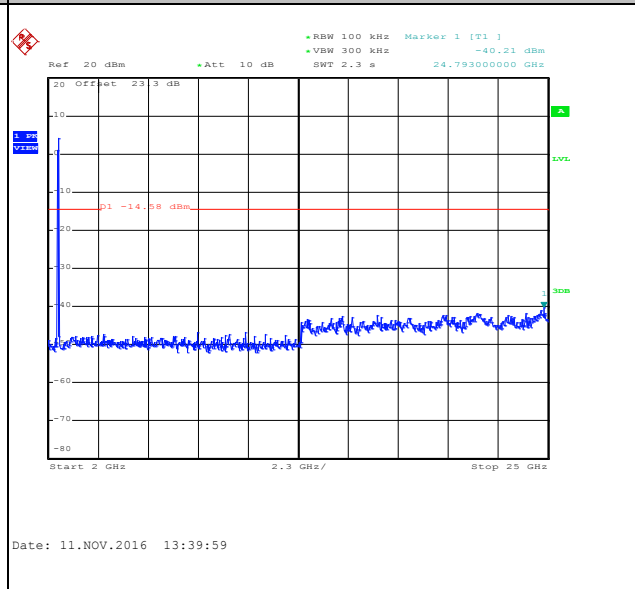



Number of TX = 2, Ant. 1 (Measured)

Number of TX :	2	Ant. :	1
Test Mode :	802.11n HT20	Temperature :	21~25°C
Test Band :	2.4GHz Low	Relative Humidity :	51~54%
Test Channel :	01	Test Engineer :	Aking Chang and Tommy Lee

WLAN 802.11n HT20 Channel 01

100kHz PSD reference Level

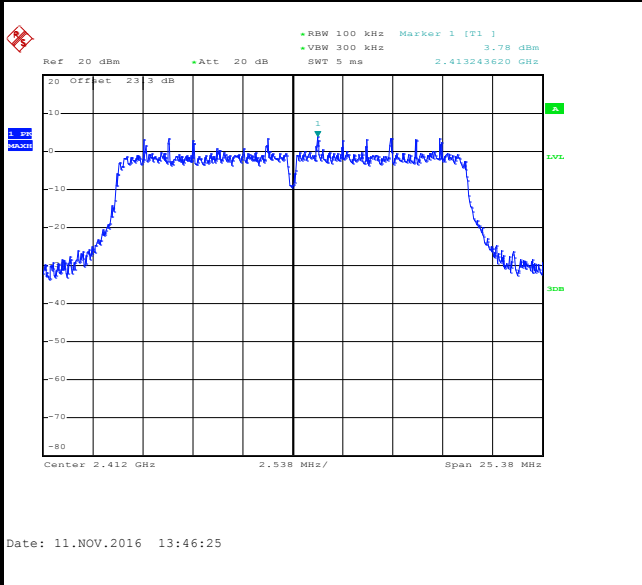

Low Channel Plot

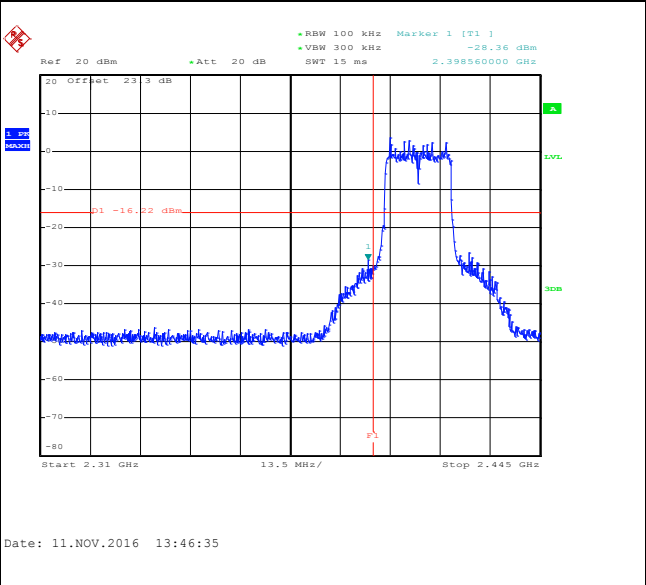

Spurious Emission 30MHz~3GHz

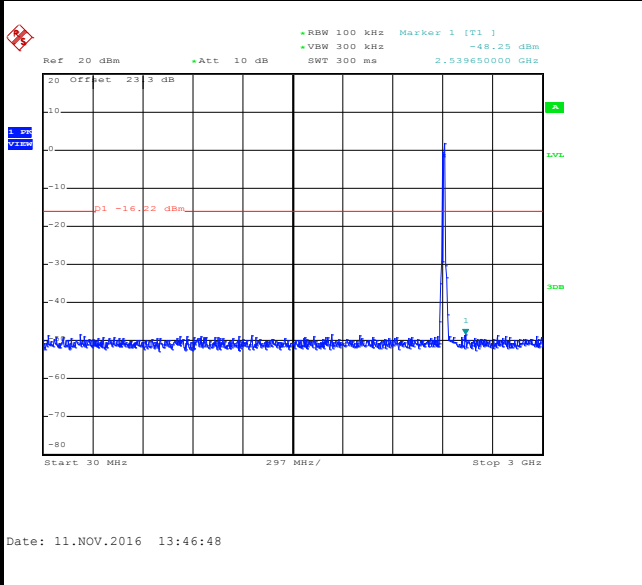

Spurious Emission 2GHz~25GHz

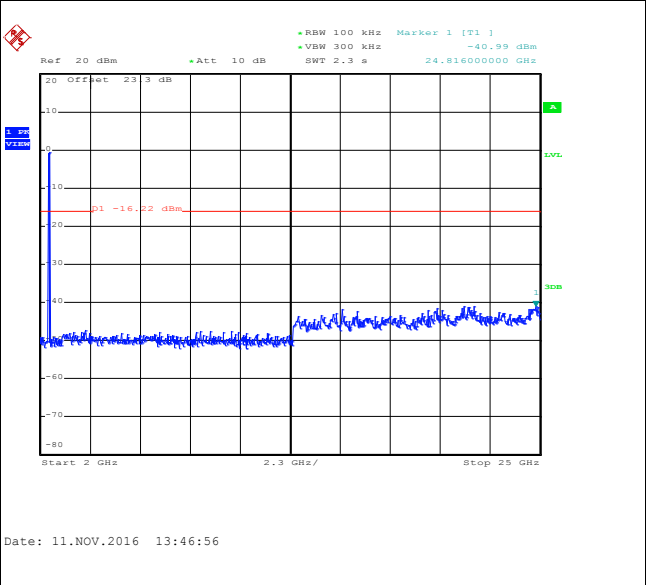



Number of TX :	2	Ant. :	1
Test Mode :	802.11n HT20	Temperature :	21~25°C
Test Band :	2.4GHz Mid	Relative Humidity :	51~54%
Test Channel :	06	Test Engineer :	Aking Chang and Tommy Lee

WLAN 802.11n HT20 Channel 06

100kHz PSD reference Level

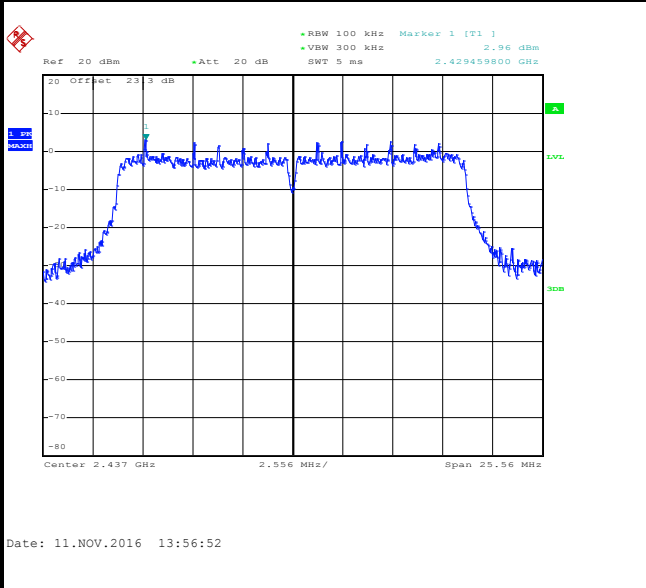

Spurious Emission 30MHz~3GHz

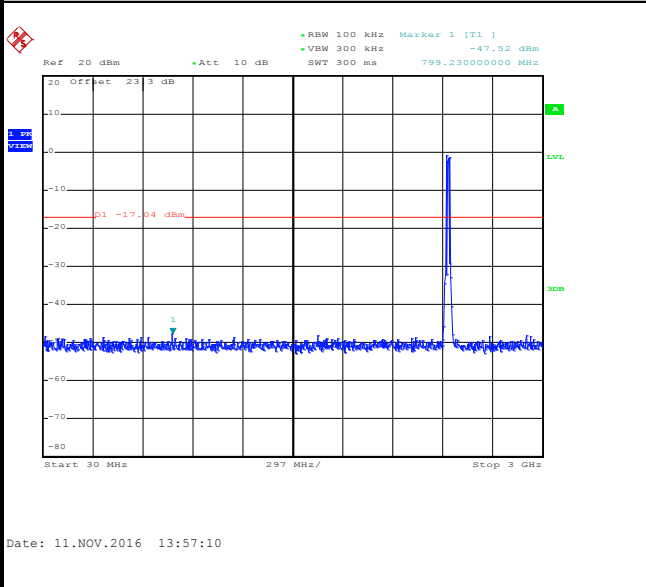

Spurious Emission 2GHz~25GHz

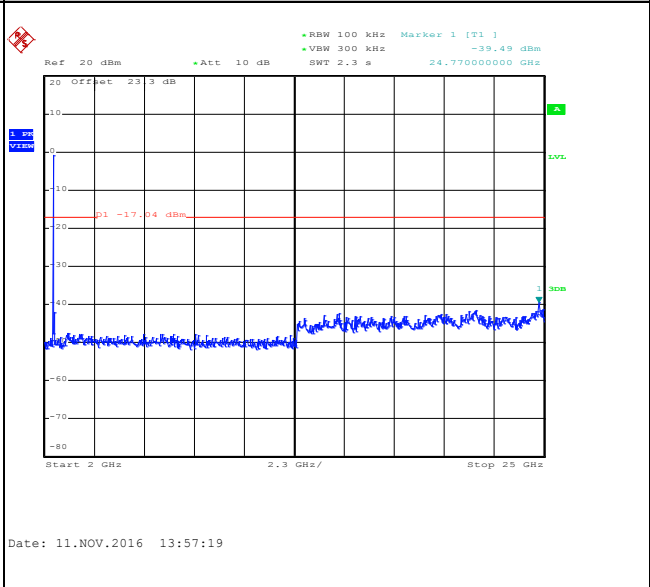



Number of TX :	2	Ant. :	1
Test Mode :	802.11n HT20	Temperature :	21~25°C
Test Band :	2.4GHz High	Relative Humidity :	51~54%
Test Channel :	11	Test Engineer :	Aking Chang and Tommy Lee

WLAN 802.11n HT20 Channel 11

100kHz PSD reference Level

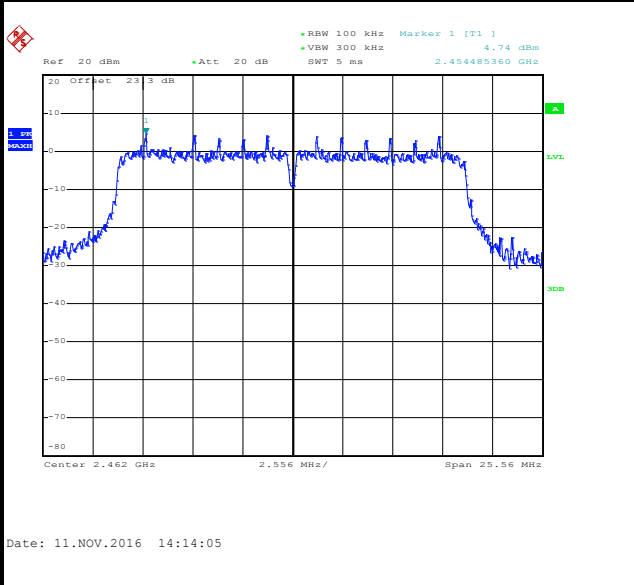

High Channel Plot

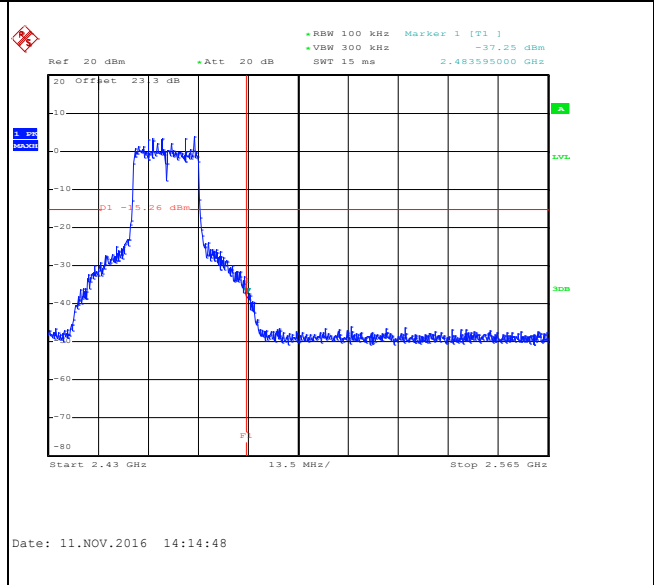

Spurious Emission 30MHz~3GHz

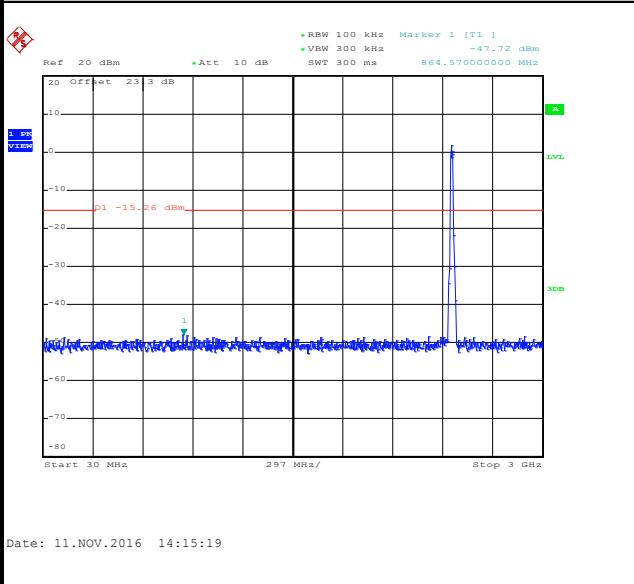

Spurious Emission 2GHz~25GHz

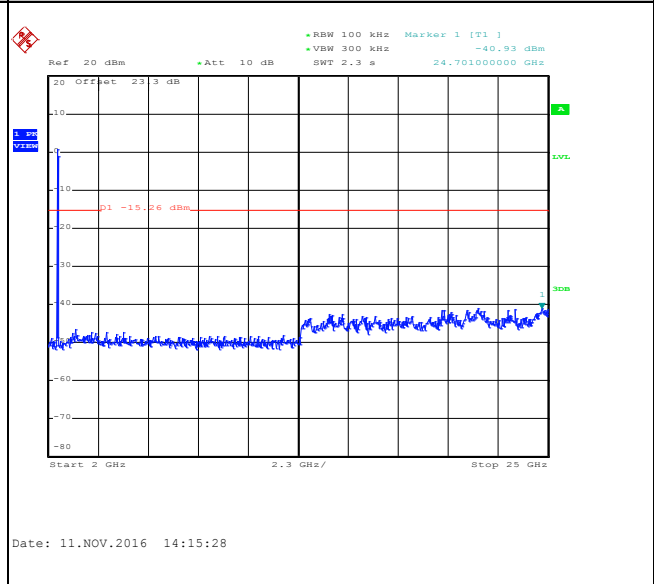



Number of TX :	2	Ant. :	1
Test Mode :	802.11n HT40	Temperature :	21~25°C
Test Band :	2.4GHz Low	Relative Humidity :	51~54%
Test Channel :	03	Test Engineer :	Aking Chang and Tommy Lee

WLAN 802.11n HT40 Channel 03

100kHz PSD reference Level

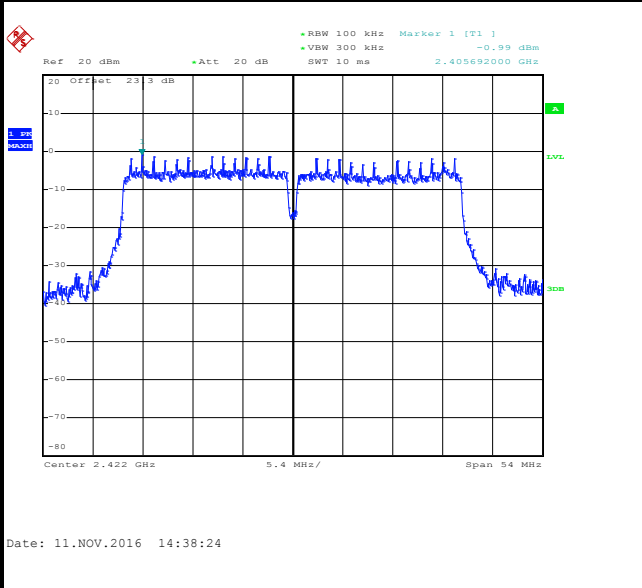

Low Channel Plot

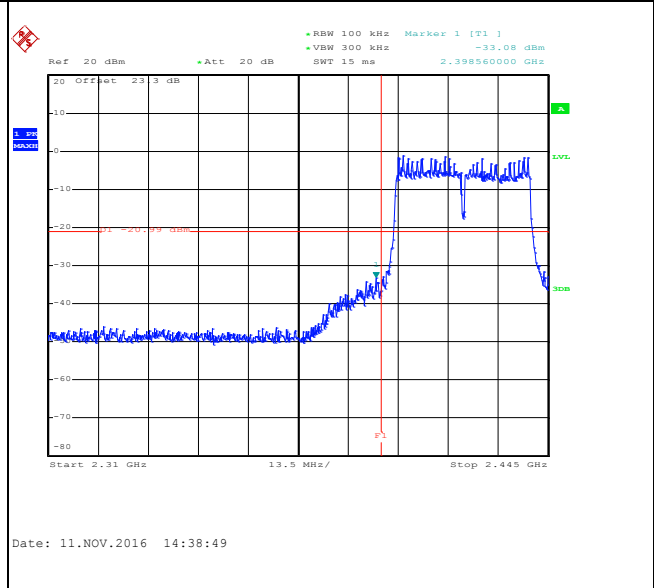

Spurious Emission 30MHz~3GHz

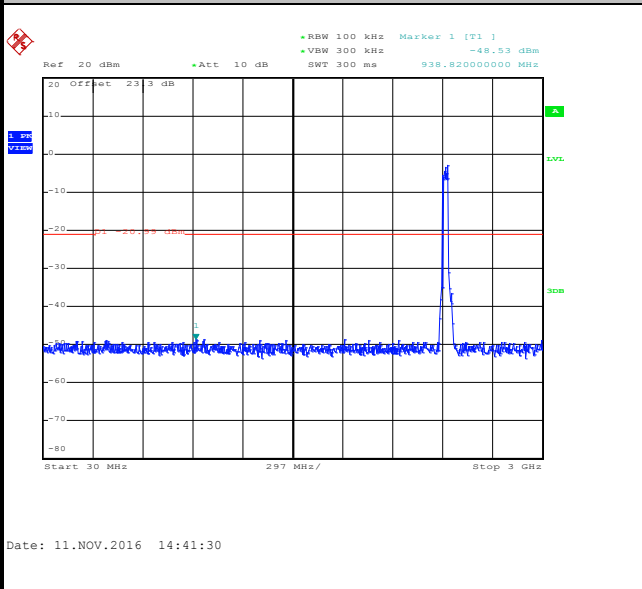

Spurious Emission 2GHz~25GHz

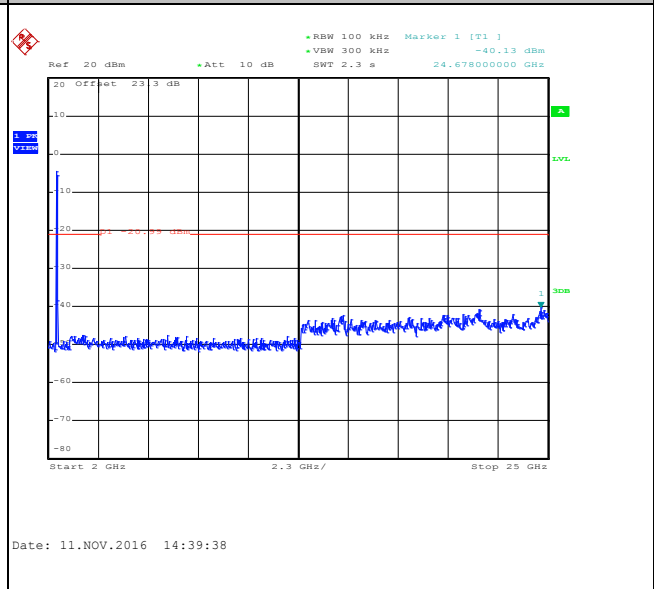



Number of TX :	2	Ant. :	1
Test Mode :	802.11n HT40	Temperature :	21~25°C
Test Band :	2.4GHz Mid	Relative Humidity :	51~54%
Test Channel :	06	Test Engineer :	Aking Chang and Tommy Lee

WLAN 802.11n HT40 Channel 06

100kHz PSD reference Level

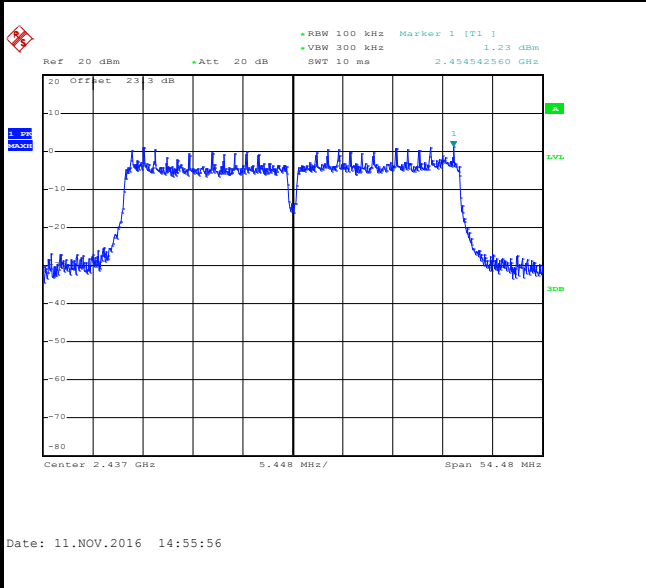

Spurious Emission 30MHz~3GHz

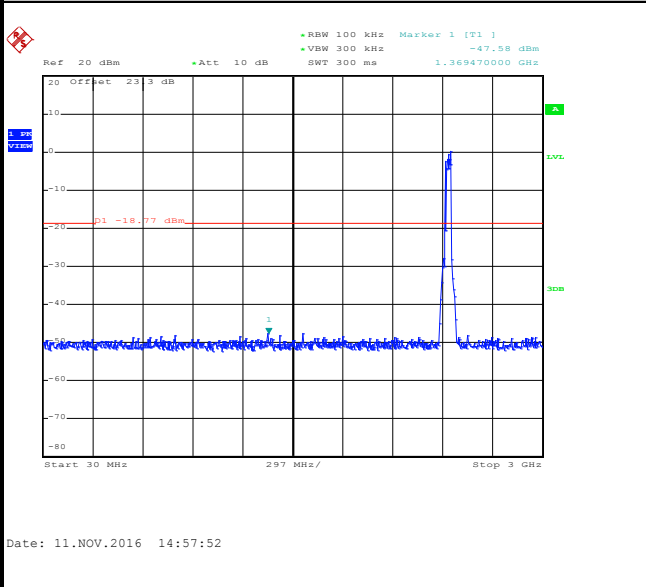

Spurious Emission 2GHz~25GHz

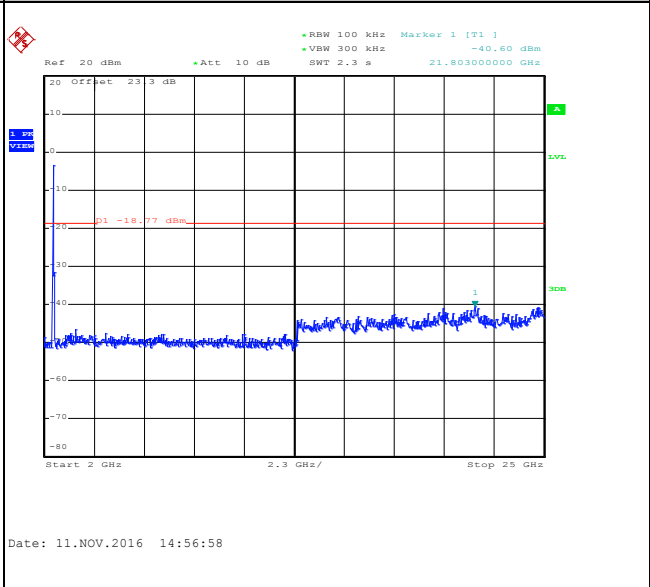



Number of TX :	2	Ant. :	1
Test Mode :	802.11n HT40	Temperature :	21~25°C
Test Band :	2.4GHz High	Relative Humidity :	51~54%
Test Channel :	09	Test Engineer :	Aking Chang and Tommy Lee

WLAN 802.11n HT40 Channel 09

100kHz PSD reference Level

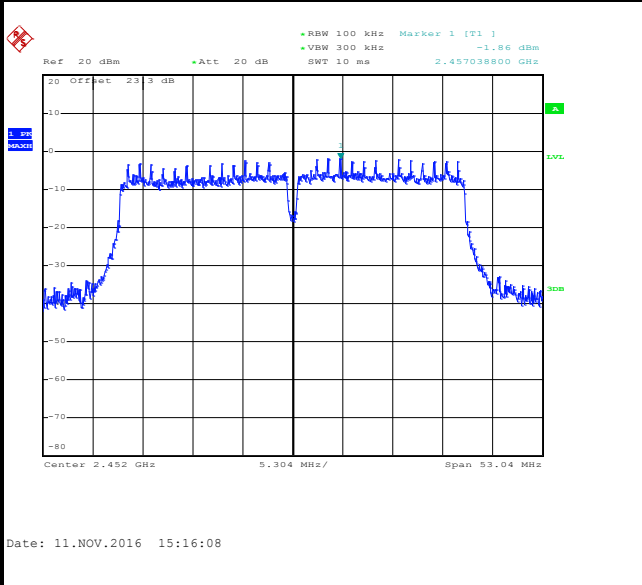

High Channel Plot

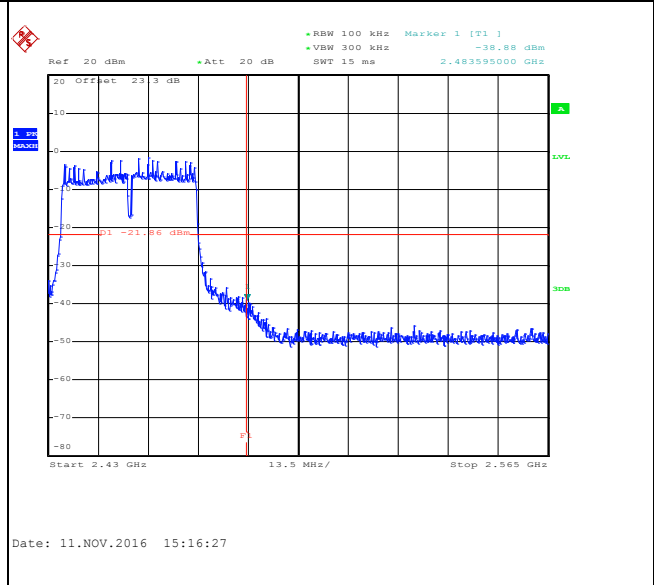

Spurious Emission 30MHz~3GHz

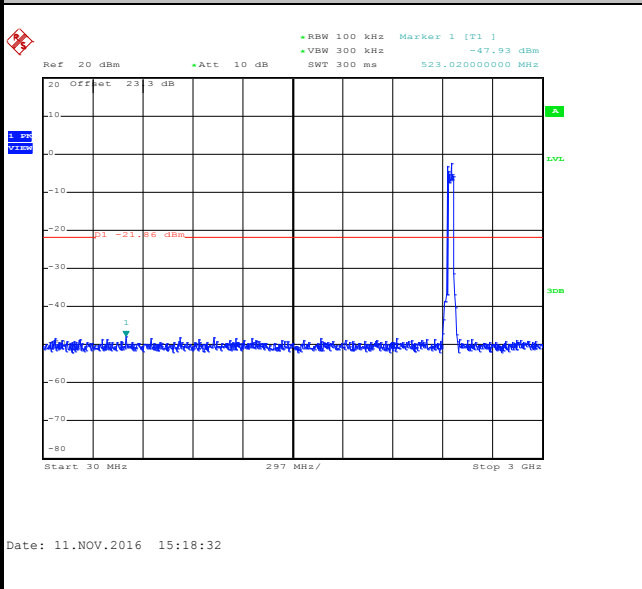

Spurious Emission 2GHz~25GHz

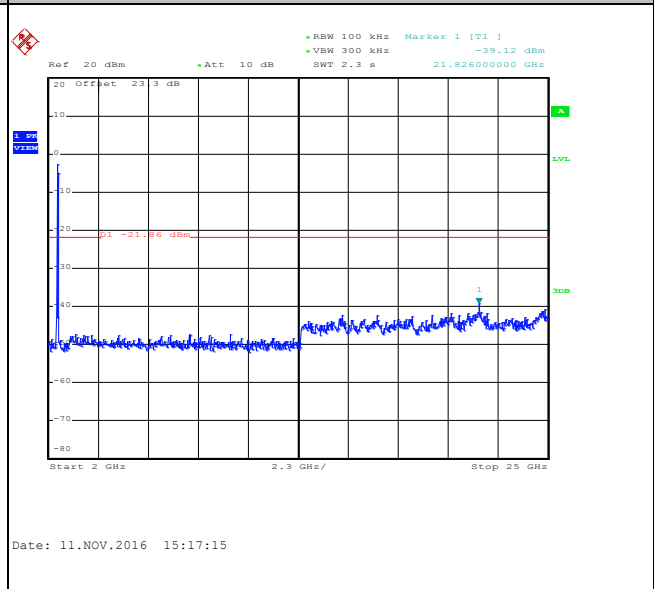





Number of TX = 2, Ant. 2 (Measured)

Number of TX :	2	Ant. :	2
Test Mode :	802.11n HT20	Temperature :	21~25°C
Test Band :	2.4GHz Low	Relative Humidity :	51~54%
Test Channel :	01	Test Engineer :	Aking Chang and Tommy Lee

WLAN 802.11n HT20 Channel 01

100kHz PSD reference Level

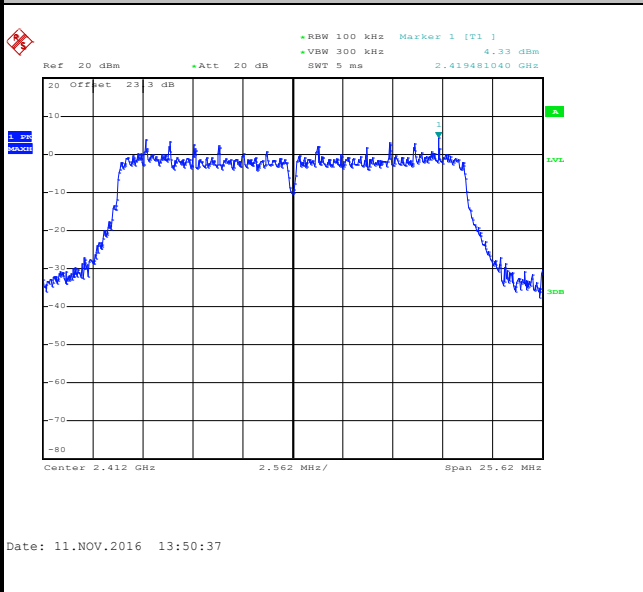

Low Channel Plot

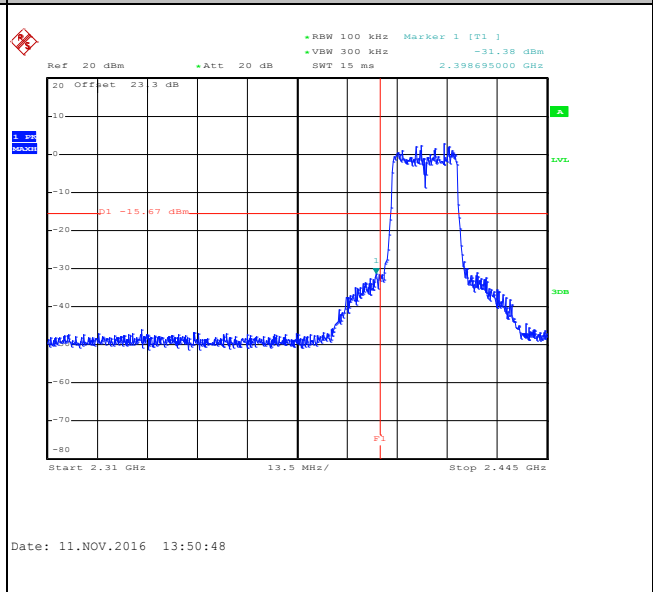

Spurious Emission 30MHz~3GHz

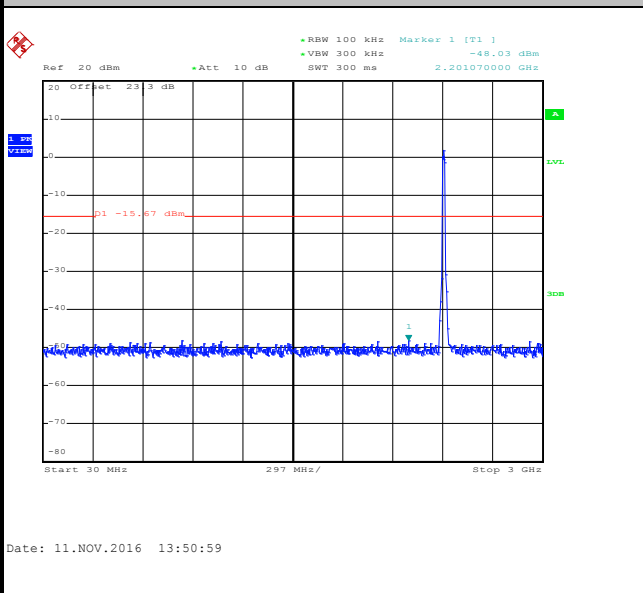

Spurious Emission 2GHz~25GHz

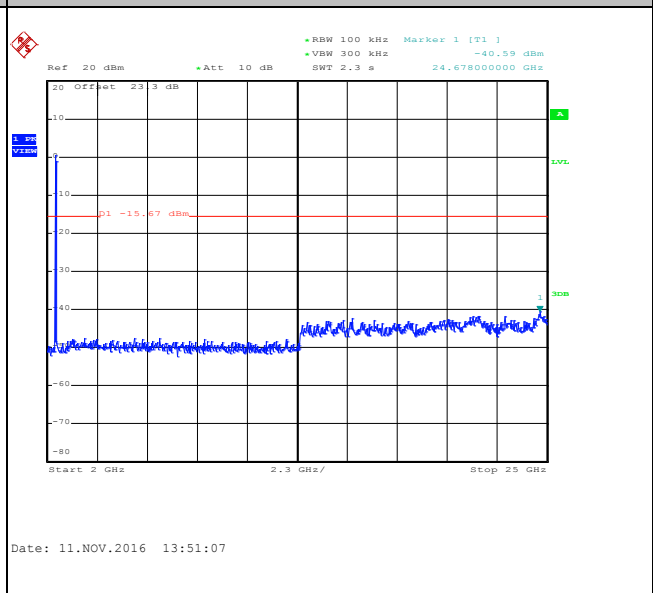



Number of TX :	2	Ant. :	2
Test Mode :	802.11n HT20	Temperature :	21~25°C
Test Band :	2.4GHz Mid	Relative Humidity :	51~54%
Test Channel :	06	Test Engineer :	Aking Chang and Tommy Lee

WLAN 802.11n HT20 Channel 06

100kHz PSD reference Level

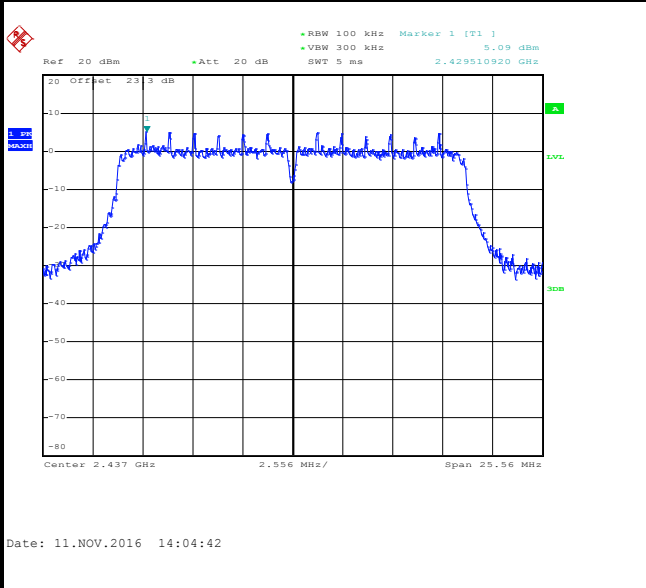

Spurious Emission 30MHz~3GHz

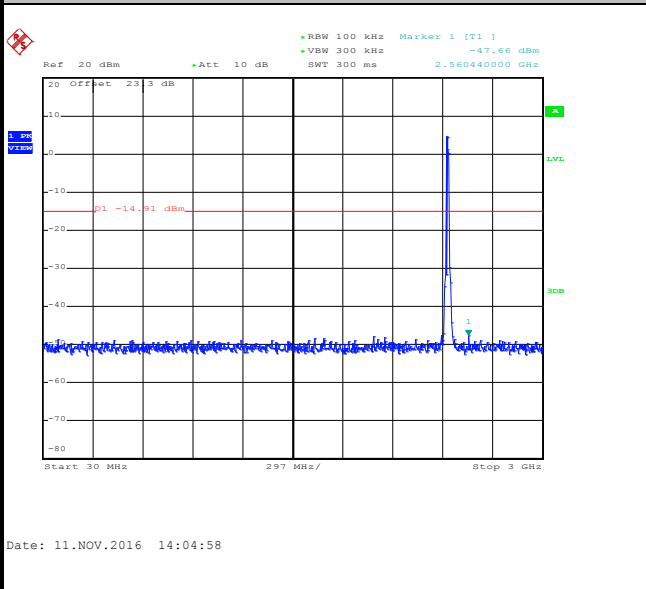

Spurious Emission 2GHz~25GHz

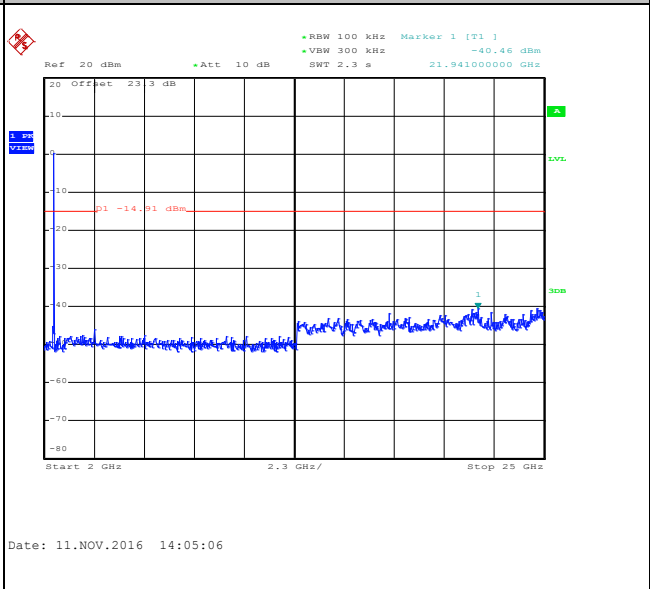



Number of TX :	2	Ant. :	2
Test Mode :	802.11n HT20	Temperature :	21~25°C
Test Band :	2.4GHz High	Relative Humidity :	51~54%
Test Channel :	11	Test Engineer :	Aking Chang and Tommy Lee

WLAN 802.11n HT20 Channel 11

100kHz PSD reference Level

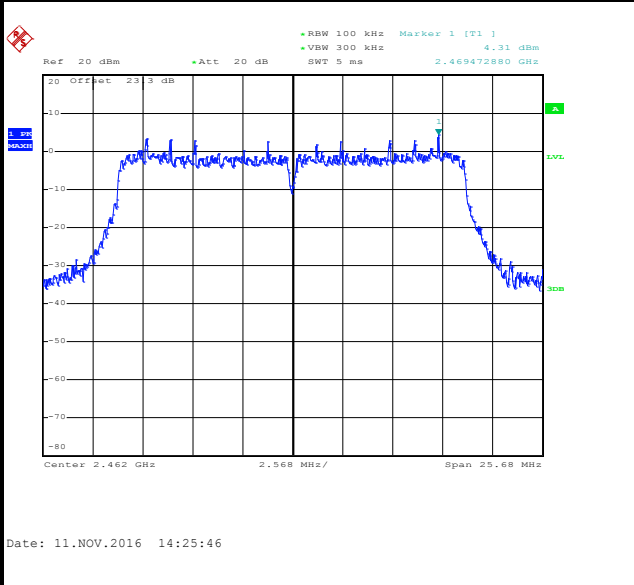

High Channel Plot

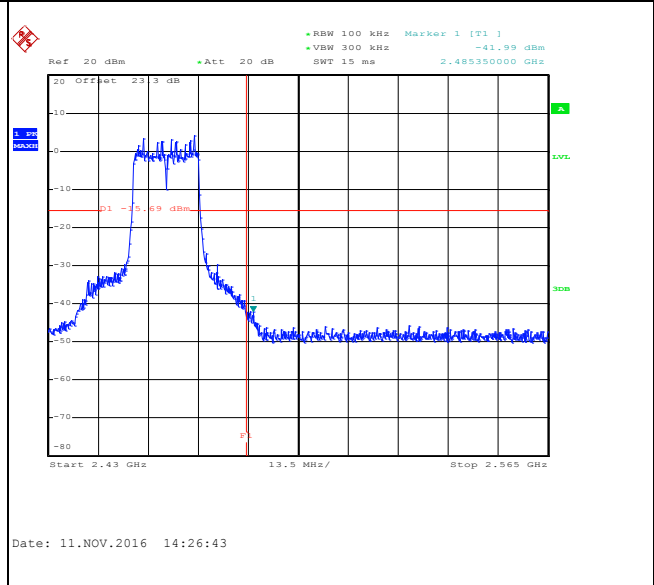

Spurious Emission 30MHz~3GHz

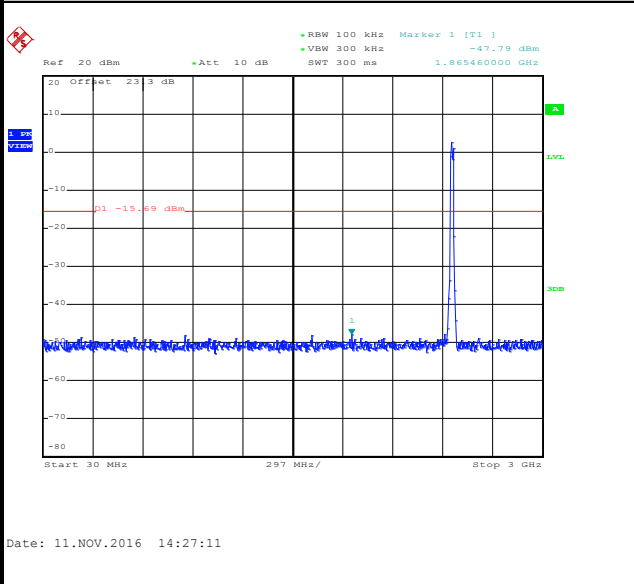

Spurious Emission 2GHz~25GHz

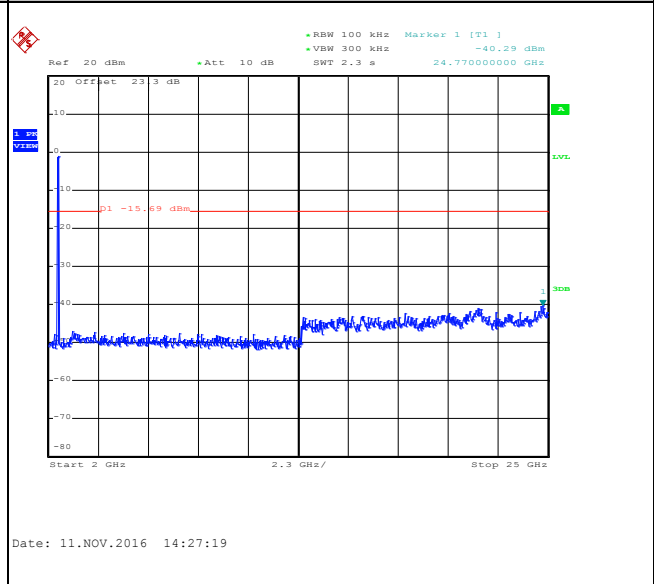



Number of TX :	2	Ant. :	2
Test Mode :	802.11n HT40	Temperature :	21~25°C
Test Band :	2.4GHz Low	Relative Humidity :	51~54%
Test Channel :	03	Test Engineer :	Aking Chang and Tommy Lee

WLAN 802.11n HT40 Channel 03

100kHz PSD reference Level

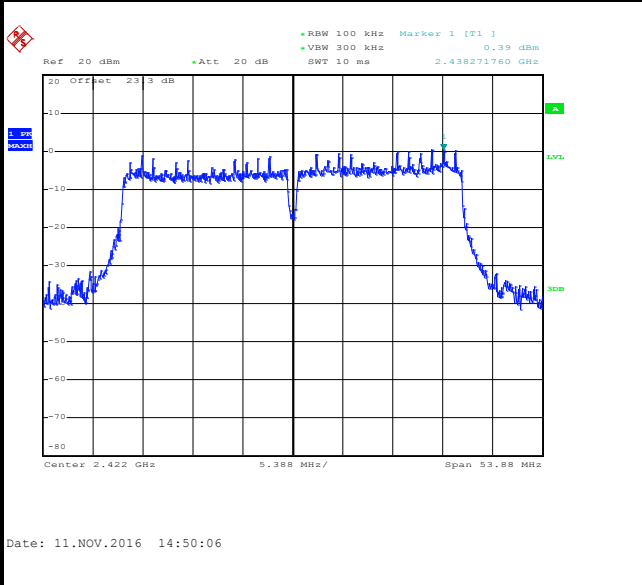

Low Channel Plot

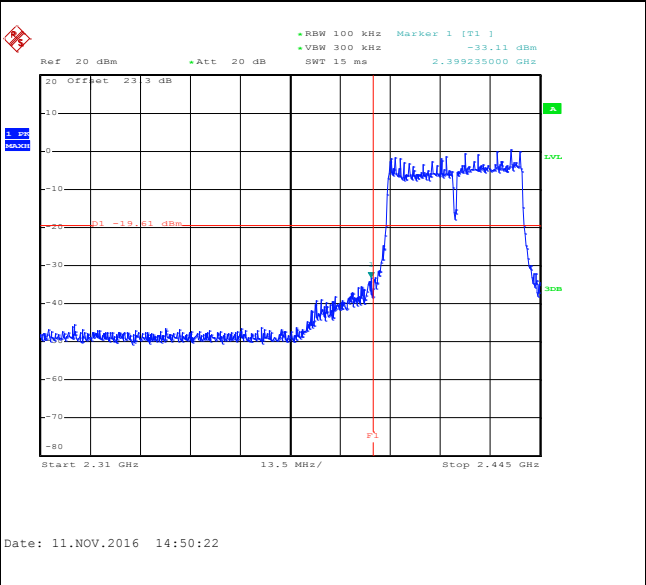

Spurious Emission 30MHz~3GHz

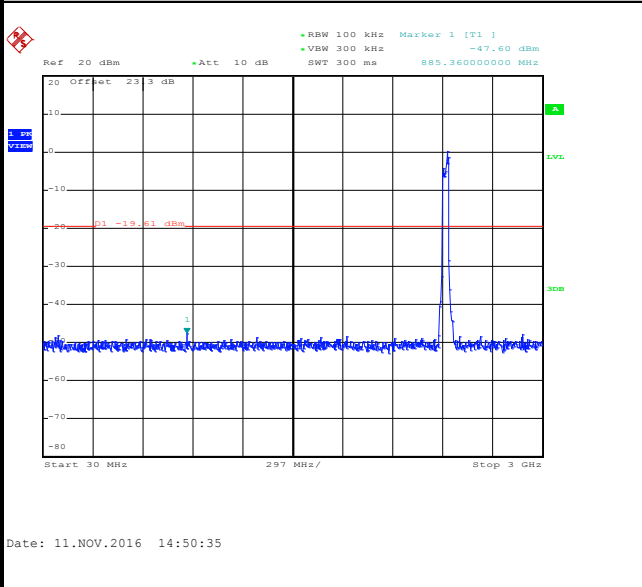

Spurious Emission 2GHz~25GHz

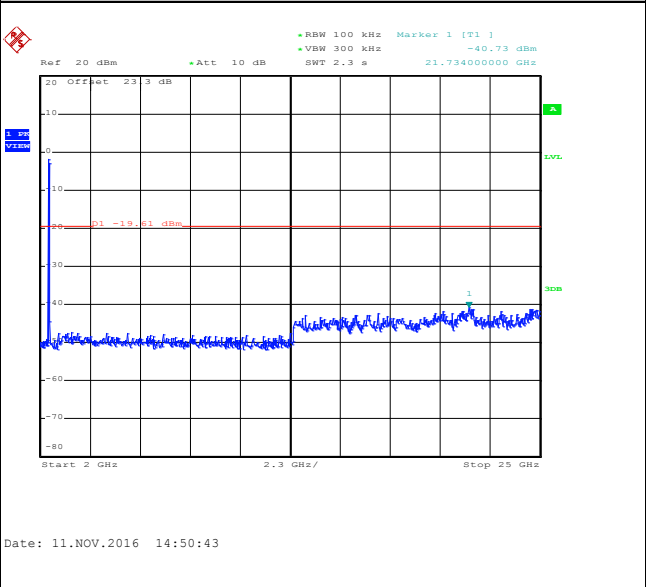



Number of TX :	2	Ant. :	2
Test Mode :	802.11n HT40	Temperature :	21~25°C
Test Band :	2.4GHz Mid	Relative Humidity :	51~54%
Test Channel :	06	Test Engineer :	Aking Chang and Tommy Lee

WLAN 802.11n HT40 Channel 06

100kHz PSD reference Level

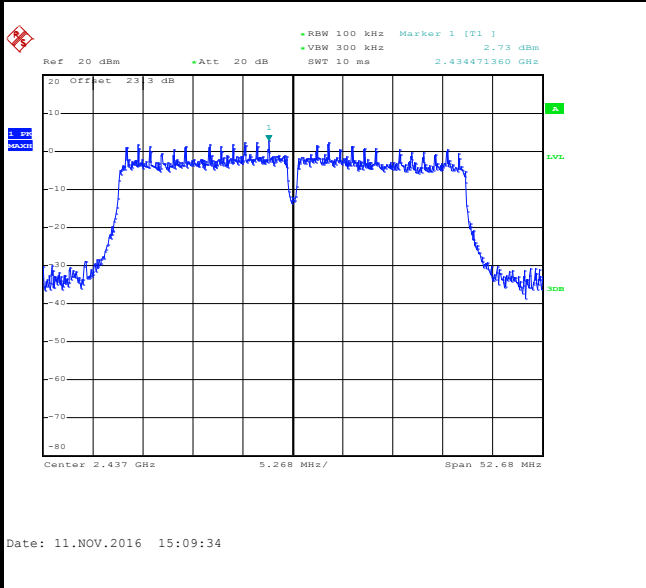

Spurious Emission 30MHz~3GHz

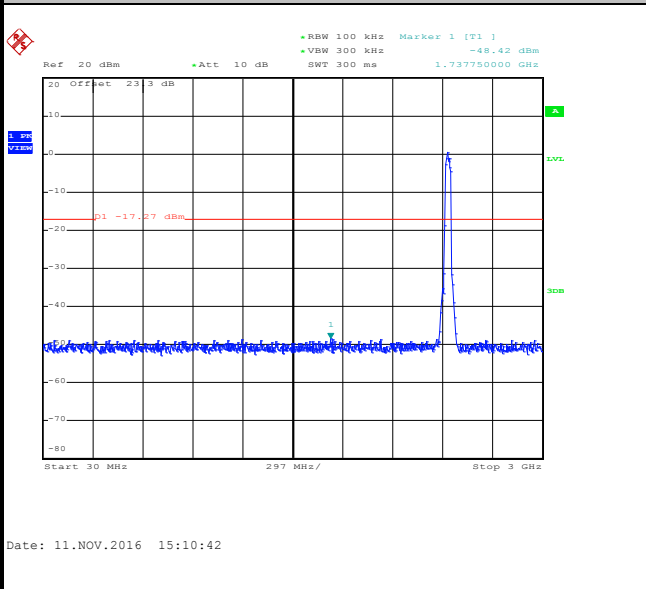

Spurious Emission 2GHz~25GHz

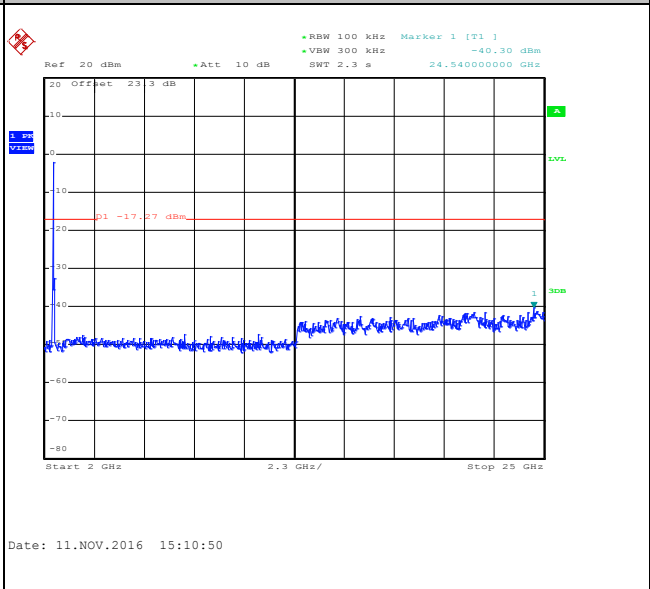



Number of TX :	2	Ant. :	2
Test Mode :	802.11n HT40	Temperature :	21~25°C
Test Band :	2.4GHz High	Relative Humidity :	51~54%
Test Channel :	09	Test Engineer :	Aking Chang and Tommy Lee

WLAN 802.11n HT40 Channel 09

100kHz PSD reference Level

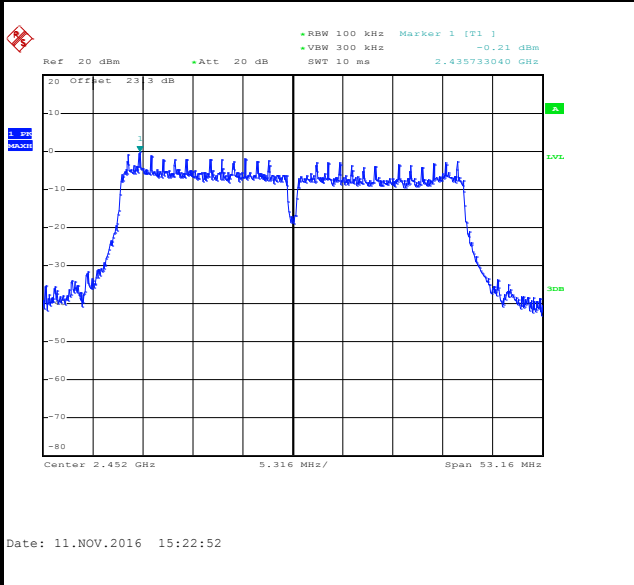

High Channel Plot

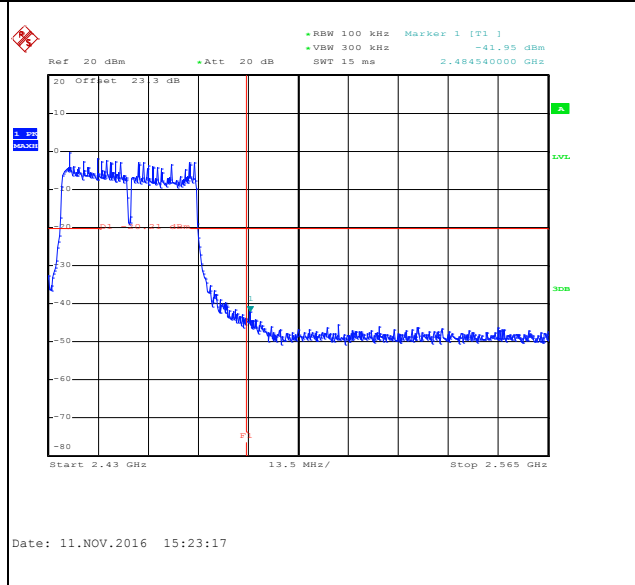

Spurious Emission 30MHz~3GHz

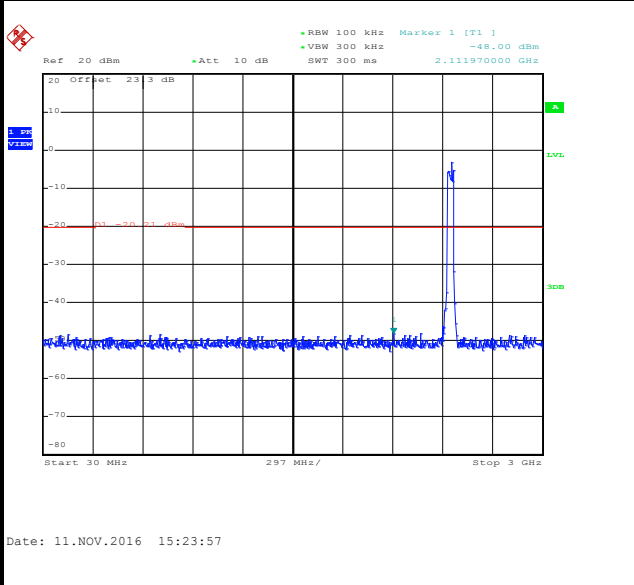

Spurious Emission 2GHz~25GHz

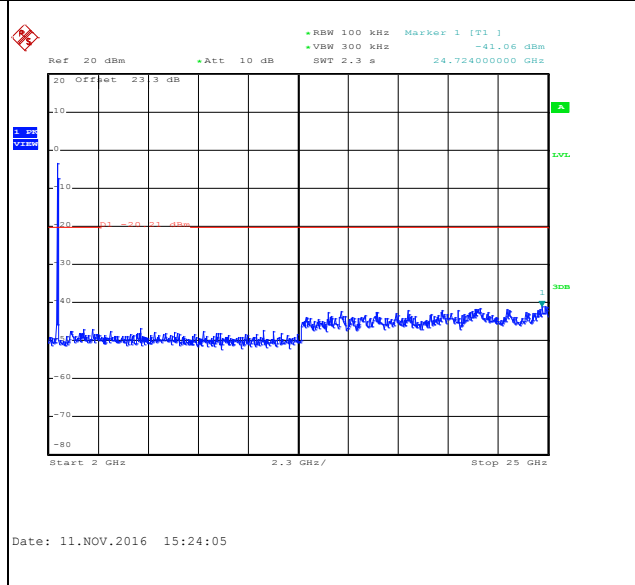



### 3.5 Radiated Band Edges and Spurious Emission Measurement

#### 3.5.1 Limit of Radiated band edge and Spurious Emission Measurement

In any 100 kHz bandwidth outside the intentional radiator frequency band, all harmonics/spurious must be at least 20 dB below the highest emission level within the authorized band. If the output power of this device was measured by spectrum analyzer, the attenuation under this paragraph shall be 30 dB instead of 20 dB. In addition, radiated emissions which fall in the restricted bands must also comply with the FCC section 15.209 limits as below.

Frequency (MHz)	Field Strength (microvolts/meter)	Measurement Distance (meters)
0.009 – 0.490	2400/F(kHz)	300
0.490 – 1.705	24000/F(kHz)	30
1.705 – 30.0	30	30
30 – 88	100	3
88 – 216	150	3
216 - 960	200	3
Above 960	500	3

#### 3.5.2 Measuring Instruments

The measuring equipment is listed in the section 4 of this test report.



### 3.5.3 Test Procedures

1. The testing follows FCC KDB Publication No. 558074 D01 DTS Meas. Guidance v03r05.
2. The EUT was arranged to its worst case and then tune the antenna tower (from 1 m to 4 m) and turntable (from 0 degree to 360 degrees) to find the maximum reading. A pre-amp and a high pass filter are used for the test in order to get better signal level.
3. The EUT was placed on a turntable with 0.8 meter for frequency below 1GHz and 1.5 meter for frequency above 1GHz respectively above ground.
4. The EUT was set 3 meters from the interference receiving antenna, which was mounted on the top of a variable height antenna tower.
5. Corrected Reading: Antenna Factor + Cable Loss + Read Level - Preamp Factor = Level
6. For measurement below 1GHz, If the emission level of the EUT measured by the peak detector is 3 dB lower than the applicable limit, the peak emission level will be reported. Otherwise, the emission measurement will be repeated using the quasi-peak detector and reported.
7. Use the following spectrum analyzer settings:
  - (1) Span shall wide enough to fully capture the emission being measured;
  - (2) Set RBW=100 kHz for  $f < 1$  GHz; VBW  $\geq$  RBW; Sweep = auto; Detector function = peak; Trace = max hold;
  - (3) Set RBW = 1 MHz, VBW= 3MHz for  $f \geq 1$  GHz for peak measurement.  
For average measurement:
    - VBW = 10 Hz, when duty cycle is no less than 98 percent.
    - VBW  $\geq 1/T$ , when duty cycle is less than 98 percent where T is the minimum transmission duration over which the transmitter is on and is transmitting at its maximum power control level for the tested mode of operation.



### 3.5.4 Test Setup

For radiated emissions below 30MHz

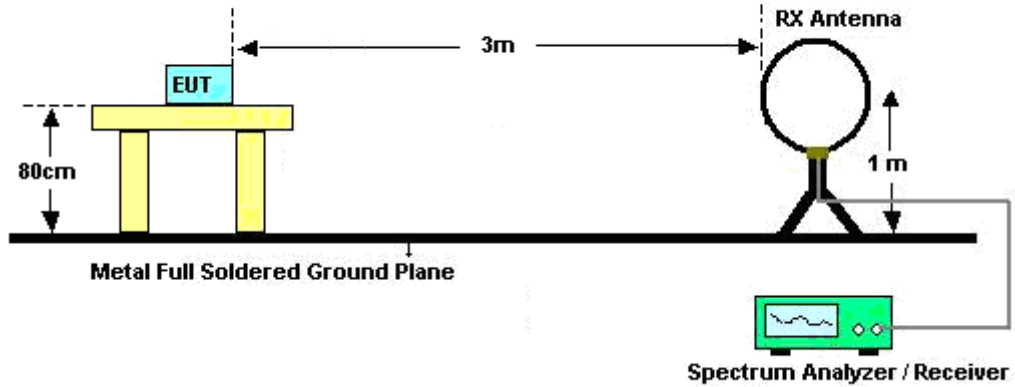

For radiated emissions from 30MHz to 1GHz

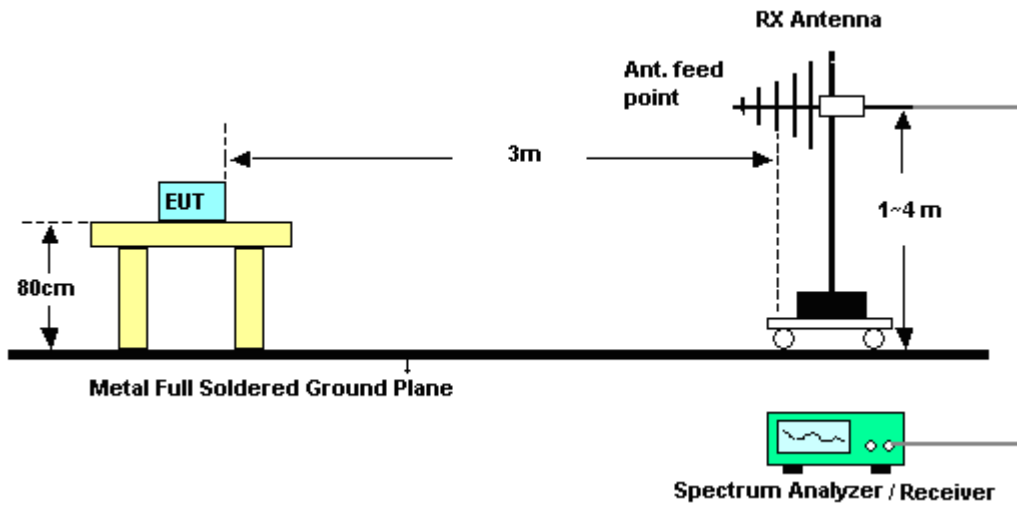

For radiated emissions above 1GHz

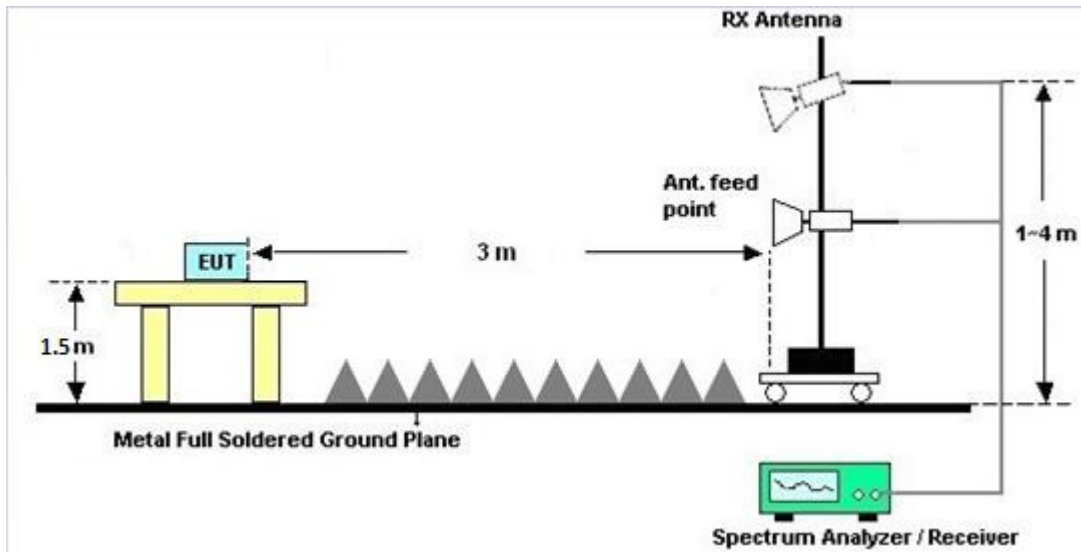

### 3.5.5 Test Results of Radiated Spurious Emissions (9kHz ~ 30MHz)

The low frequency, which started from 9 kHz to 30MHz, was pre-scanned and the result which was 20dB lower than the limit line per 15.31(o) was not reported.

### 3.5.6 Test Result of Radiated Spurious at Band Edges

Please refer to Appendix B and C.

### 3.5.7 Duty Cycle

Please refer to Appendix D.

### 3.5.8 Test Result of Radiated Spurious Emission (30MHz ~ 10<sup>th</sup> Harmonic)

Please refer to Appendix B and C.



### 3.6 AC Conducted Emission Measurement

#### 3.6.1 Limit of AC Conducted Emission

For equipment that is designed to be connected to the public utility (AC) power line, the radio frequency voltage that is conducted back onto the AC power line on any frequency or frequencies within the band 150 kHz to 30 MHz shall not exceed the limits in the following table.

Frequency of Emission (MHz)	Conducted Limit (dB $\mu$ V)	
	Quasi-Peak	Average
0.15-0.5	66 to 56*	56 to 46*
0.5-5	56	46
5-30	60	50

\*Decreases with the logarithm of the frequency.

#### 3.6.2 Measuring Instruments

The measuring equipment is listed in the section 4 of this test report.

#### 3.6.3 Test Procedures

1. The EUT was placed 0.4 meter from the conducting wall of the shielding room, and it was kept at least 80 centimeters from any other grounded conducting surface.
2. Connect EUT to the power mains through a line impedance stabilization network (LISN).
3. All the support units are connecting to the other LISN.
4. The LISN provides 50 ohm coupling impedance for the measuring instrument.
5. The FCC states that a 50 ohm, 50 microhenry LISN should be used.
6. Both sides of AC line were checked for maximum conducted interference.
7. The frequency range from 150 kHz to 30 MHz was searched.
8. Set the test-receiver system to Peak Detect Function and specified bandwidth (IF bandwidth = 9kHz) with Maximum Hold Mode.

### 3.6.4 Test Setup

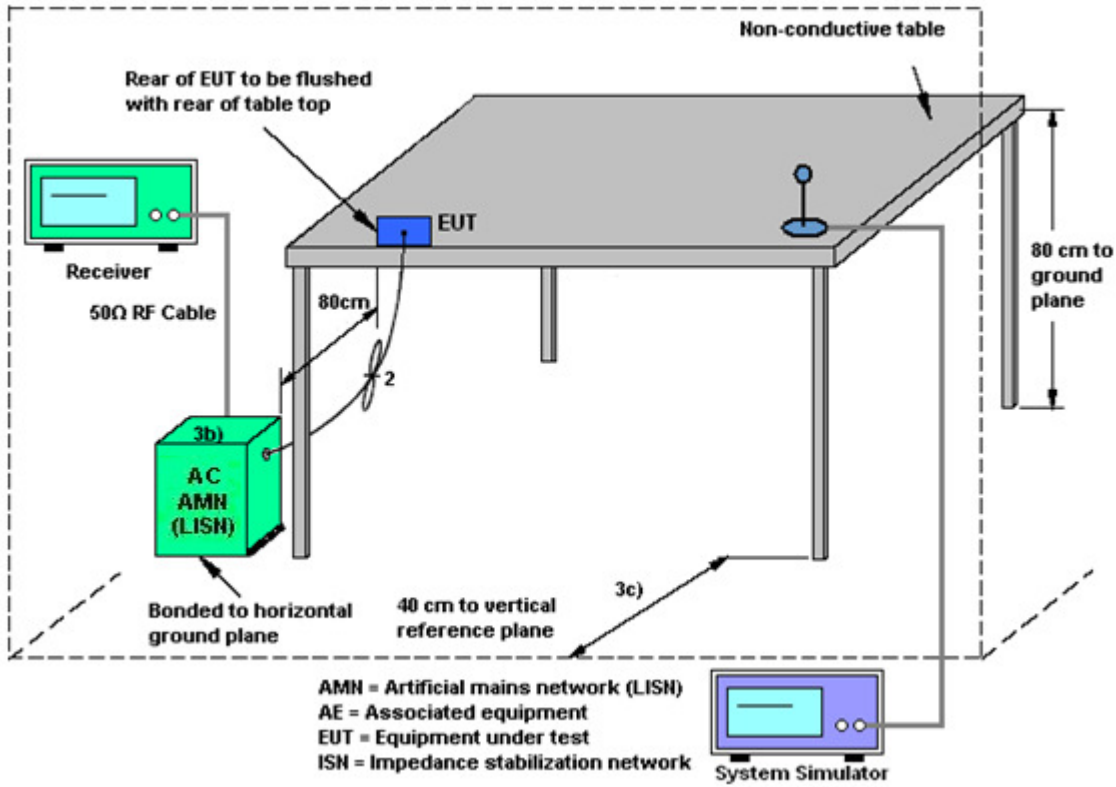



### 3.6.5 Test Result of AC Conducted Emission

Test Mode :	Mode 1	Temperature :	22~24°C
Test Engineer :	James Chiu	Relative Humidity :	51~55%
Test Voltage :	120Vac / 60Hz	Phase :	Line
Function Type :	GSM850 (GPRS class 8) Idle + WLAN (2.4GHz) Link + LAN Link + WAN Link + Adapter		

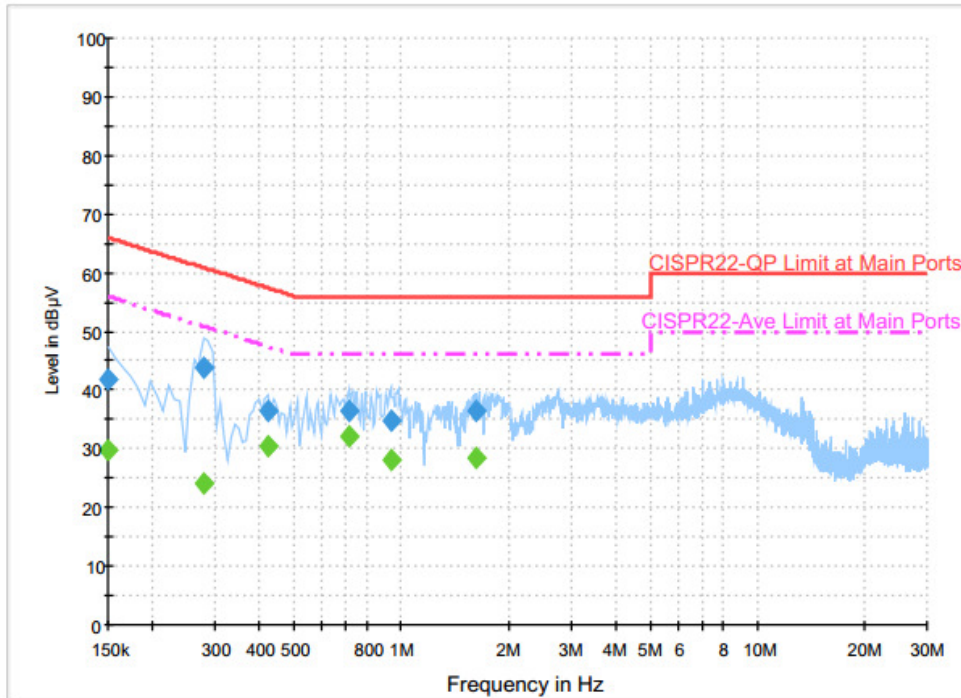

#### Final Result : QuasiPeak

Frequency (MHz)	QuasiPeak (dBµV)	Filter	Line	Corr. (dB)	Margin (dB)	Limit (dBµV)
0.150000	41.8	Off	L1	19.6	24.2	66.0
0.278000	43.9	Off	L1	19.6	17.0	60.9
0.422000	36.4	Off	L1	19.6	21.0	57.4
0.710000	36.5	Off	L1	19.6	19.5	56.0
0.934000	34.7	Off	L1	19.7	21.3	56.0
1.622000	36.3	Off	L1	19.7	19.7	56.0

#### Final Result : Average

Frequency (MHz)	Average (dBµV)	Filter	Line	Corr. (dB)	Margin (dB)	Limit (dBµV)
0.150000	29.7	Off	L1	19.6	26.3	56.0
0.278000	23.9	Off	L1	19.6	27.0	50.9
0.422000	30.3	Off	L1	19.6	17.1	47.4
0.710000	32.0	Off	L1	19.6	14.0	46.0
0.934000	28.2	Off	L1	19.7	17.8	46.0
1.622000	28.3	Off	L1	19.7	17.7	46.0



Test Mode :	Mode 1	Temperature :	22~24°C
Test Engineer :	James Chiu	Relative Humidity :	51~55%
Test Voltage :	120Vac / 60Hz	Phase :	Neutral
Function Type :	GSM850 (GPRS class 8) Idle + WLAN (2.4GHz) Link + LAN Link + WAN Link + Adapter		

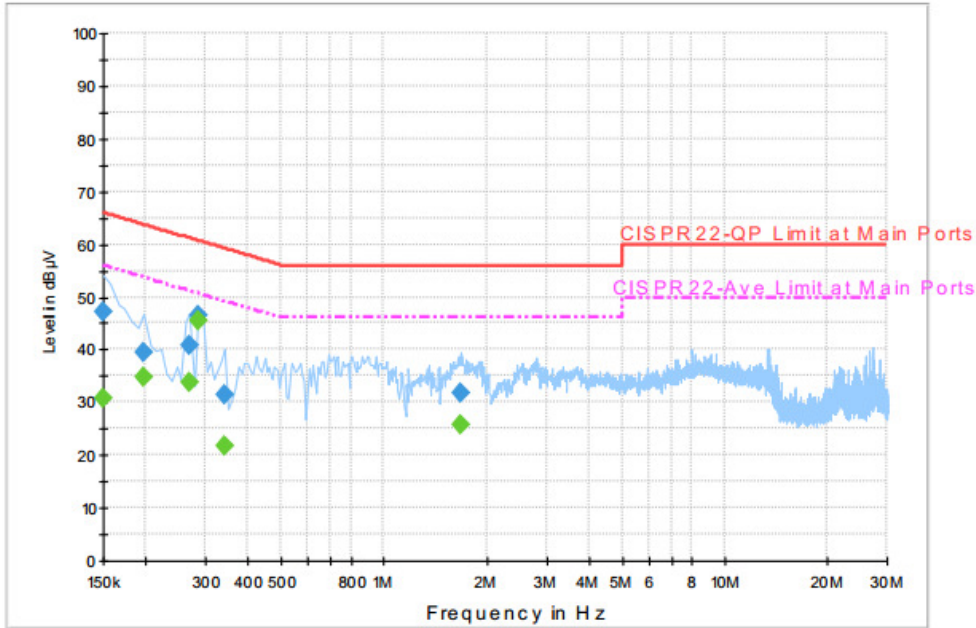

**Final Result : QuasiPeak**

Frequency (MHz)	QuasiPeak (dBµV)	Filter	Line	Corr. (dB)	Margin (dB)	Limit (dBµV)
0.150000	47.0	Off	N	19.6	19.0	66.0
0.198000	39.5	Off	N	19.6	24.2	63.7
0.270000	40.7	Off	N	19.6	20.4	61.1
0.286000	46.4	Off	N	19.6	14.2	60.6
0.342000	31.5	Off	N	19.6	27.7	59.2
1.686000	31.9	Off	N	19.7	24.1	56.0

**Final Result : Average**

Frequency (MHz)	Average (dBµV)	Filter	Line	Corr. (dB)	Margin (dB)	Limit (dBµV)
0.150000	30.8	Off	N	19.6	25.2	56.0
0.198000	34.6	Off	N	19.6	19.1	53.7
0.270000	33.9	Off	N	19.6	17.2	51.1
0.286000	45.3	Off	N	19.6	5.3	50.6
0.342000	21.7	Off	N	19.6	27.5	49.2
1.686000	25.8	Off	N	19.7	20.2	46.0



### 3.7 Antenna Requirements

#### 3.7.1 Standard Applicable

If directional gain of transmitting Antennas is greater than 6dBi, the power shall be reduced by the same level in dB comparing to gain minus 6dBi. For the fixed point-to-point operation, the power shall be reduced by one dB for every 3 dB that the directional gain of the Antenna exceeds 6 dBi. The use of a permanently attached Antenna or of an Antenna that uses a unique coupling to the intentional radiator shall be considered sufficient to comply with the FCC rule.

#### 3.7.2 Antenna Anti-Replacement Construction

An embedded-in antenna design is used.

#### 3.7.3 Antenna Gain

FCC KDB 662911 D01 Multiple Transmitter Output v02r01

For power, the directional gain  $G_{ANT}$  is set equal to the antenna having the highest gain, i.e., F)2)f)i).

For PSD, the directional gain calculation is following F)2)f)ii) of KDB 662911 D01 v02r01.

The power and PSD limit should be modified if the directional gain of EUT is over 6 dBi,

The directional gain "DG" is calculated as following table.

			DG	DG	Power	PSD
			for	for	Limit	Limit
	Ant. 1	Ant. 2	Power	PSD	Reduction	Reduction
	(dBi)	(dBi)	(dBi)	(dBi)	(dB)	(dB)
2.4 GHz	3.80	3.80	3.80	3.80	0.00	0.00

$$Power\ Limit\ Reduction = DG(Power) - 6dBi, (min = 0)$$

$$PSD\ Limit\ Reduction = DG(PSD) - 6dBi, (min = 0)$$



## 4 List of Measuring Equipment

Instrument	Manufacturer	Model No.	Serial No.	Characteristics	Calibration Date	Test Date	Due Date	Remark
Power Meter	Anritsu	ML2495A	0932001	300MHz~40GHz	Sep. 29, 2016	Nov. 10, 2016 ~ Nov. 11, 2016	Sep. 28, 2017	Conducted (TH05-HY)
Power Sensor	Anritsu	MA2411B	0846202	300MHz~40GHz	Sep. 29, 2016	Nov. 10, 2016 ~ Nov. 11, 2016	Sep. 28, 2017	Conducted (TH05-HY)
Spectrum Analyzer	Rohde & Schwarz	FSP40	100055	9kHz-40GHz	Jul. 17, 2016	Nov. 10, 2016 ~ Nov. 11, 2016	Jul. 16, 2017	Conducted (TH05-HY)
AC Power Source	ChainTek	APC-1000W	N/A	N/A	N/A	Nov. 03, 2016	N/A	Conduction (CO05-HY)
EMI Test Receiver	Rohde & Schwarz	ESCI 7	100724	9kHz~7GHz	Aug. 30, 2016	Nov. 03, 2016	Aug. 29, 2017	Conduction (CO05-HY)
LISN	Rohde & Schwarz	ENV216	100080	9kHz~30MHz	Dec. 02, 2015	Nov. 03, 2016	Dec. 01, 2016	Conduction (CO05-HY)
LISN	Rohde & Schwarz	ENV216	100081	9kHz~30MHz	Dec. 14, 2015	Nov. 03, 2016	Dec. 13, 2016	Conduction (CO05-HY)
Loop Antenna	Rohde & Schwarz	HFH2-Z2	100315	9 kHz~30 MHz	Sep. 02, 2015	Nov. 07, 2016 ~ Nov. 09, 2016	Sep. 01, 2017	Radiation (03CH12-HY)
Amplifier	SONOMA	310N	187312	9kHz~1GHz	Nov. 20, 2015	Nov. 07, 2016 ~ Nov. 09, 2016	Nov. 19, 2016	Radiation (03CH12-HY)
Bilog Antenna	TESEQ	CBL 6111D&00800 N1D01N-06	37059&01	30MHz~1GHz	Oct. 15, 2016	Nov. 07, 2016 ~ Nov. 09, 2016	Oct. 14, 2017	Radiation (03CH12-HY)
EMI Test Receiver	Rohde & Schwarz	ESU26	100390	20Hz~26.5GHz	Dec. 21, 2015	Nov. 07, 2016 ~ Nov. 09, 2016	Dec. 20, 2016	Radiation (03CH12-HY)
Preamplifier	MITEQ	TTA0204	1872107	2GHz~40GHz	Feb. 15, 2016	Nov. 07, 2016 ~ Nov. 09, 2016	Feb. 14, 2017	Radiation (03CH12-HY)
Horn Antenna	SCHWARZBE CK	BBHA 9120 D	9120D-1522	1G~18GHz	Mar. 31, 2016	Nov. 07, 2016 ~ Nov. 09, 2016	Mar. 30, 2017	Radiation (03CH12-HY)
Preamplifier	MITEQ	AMF-7D-00101 800-30-10P	1815698	1GHz~18GHz	Dec. 14, 2015	Nov. 07, 2016 ~ Nov. 09, 2016	Dec. 13, 2016	Radiation (03CH12-HY)
Preamplifier	Keysight	83017A	MY53270148	1GHz~26.5GHz	Jan. 30, 2016	Nov. 07, 2016 ~ Nov. 09, 2016	Jan. 29, 2017	Radiation (03CH12-HY)
Antenna Mast	EMEC	AM-BS-4500-B	N/A	1m~4m	N/A	Nov. 07, 2016 ~ Nov. 09, 2016	N/A	Radiation (03CH12-HY)
Turn Table	EMEC	TT2000	N/A	0~360 Degree	N/A	Nov. 07, 2016 ~ Nov. 09, 2016	N/A	Radiation (03CH12-HY)
SHF-EHF Horn Antenna	SCHWARZBE CK	BBHA 9170	BBHA91705 76	18GHz ~ 40GHz	Apr. 15, 2016	Nov. 07, 2016 ~ Nov. 09, 2016	Apr. 14, 2017	Radiation (03CH12-HY)





## 5 Uncertainty of Evaluation

### Uncertainty of Conducted Emission Measurement (150kHz ~ 30MHz)

Measuring Uncertainty for a Level of Confidence of 95% ( $U = 2Uc(y)$ )	2.7
---	-----

### Uncertainty of Radiated Emission Measurement (30 MHz ~ 1000 MHz)

Measuring Uncertainty for a Level of Confidence of 95% ( $U = 2Uc(y)$ )	5.1
---	-----

### Uncertainty of Radiated Emission Measurement (1000 MHz ~ 18000 MHz)

Measuring Uncertainty for a Level of Confidence of 95% ( $U = 2Uc(y)$ )	5.2
---	-----

### Uncertainty of Radiated Emission Measurement (18000 MHz ~ 40000 MHz)

Measuring Uncertainty for a Level of Confidence of 95% ( $U = 2Uc(y)$ )	4.7
---	-----



## **Appendix A. Conducted Test Results**

**A1 - DTS Part**

Test Engineer:	Aking Chang / Tommy Lee	Temperature:	21~25	°C
Test Date:	2016/11/10~2016/11/11	Relative Humidity:	51~54	%

**TEST RESULTS DATA**  
**6dB and 99% Occupied Bandwidth**

2.4GHz Band										
Mod.	Data Rate	NTX	CH.	Freq. (MHz)	99% Occupied BW (MHz)		6dB BW (MHz)		6dB BW Limit (MHz)	Pass/Fail
					Ant 1	Ant 2	Ant 1	Ant 2		
11b	1Mbps	1	1	2412	12.35		9.32		0.50	Pass
11b	1Mbps	1	6	2437	12.40		10.00		0.50	Pass
11b	1Mbps	1	11	2462	12.30		9.28		0.50	Pass
11g	6Mbps	1	1	2412	18.00		16.28		0.50	Pass
11g	6Mbps	1	6	2437	18.30		16.28		0.50	Pass
11g	6Mbps	1	11	2462	17.70		16.32		0.50	Pass
HT20	MCS8	2	1	2412	18.35	18.40	16.92	17.08	0.50	Pass
HT20	MCS8	2	6	2437	18.60	18.50	17.04	17.04	0.50	Pass
HT20	MCS8	2	11	2462	18.50	18.45	17.04	17.12	0.50	Pass
HT40	MCS8	2	3	2422	36.80	36.80	36.00	35.92	0.50	Pass
HT40	MCS8	2	6	2437	37.10	36.50	36.32	35.12	0.50	Pass
HT40	MCS8	2	9	2452	36.60	36.90	35.36	35.44	0.50	Pass

**TEST RESULTS DATA**  
**Peak Output Power**

2.4GHz Band																
Mod.	Data Rate	NTX	CH.	Freq. (MHz)	Peak Conducted Power (dBm)			Conducted Power Limit (dBm)		DG (dBi)		EIRP Power (dBm)		EIRP Power Limit (dBm)		Pass /Fail
					Ant 1	Ant 2	SUM	Ant 1	Ant 2	Ant 1	Ant 2	Ant 1	Ant 2	Ant 1	Ant 2	
11b	1Mbps	1	1	2412	17.60	17.55		30.00	30.00	3.80	3.80	21.40	21.35	36.00	36.00	Pass
11b	1Mbps	1	6	2437	15.95	15.71		30.00	30.00	3.80	3.80	19.75	19.51	36.00	36.00	Pass
11b	1Mbps	1	11	2462	17.10	16.80		30.00	30.00	3.80	3.80	20.90	20.60	36.00	36.00	Pass
11g	6Mbps	1	1	2412	22.54	22.50		30.00	30.00	3.80	3.80	26.34	26.30	36.00	36.00	Pass
11g	6Mbps	1	6	2437	21.43	21.42		30.00	30.00	3.80	3.80	25.23	25.22	36.00	36.00	Pass
11g	6Mbps	1	11	2462	23.04	22.32		30.00	30.00	3.80	3.80	26.84	26.12	36.00	36.00	Pass
HT20	MCS0	1	1	2412	22.17	22.55		30.00	30.00	3.80	3.80	25.97	26.35	36.00	36.00	Pass
HT20	MCS0	1	6	2437	21.94	23.27		30.00	30.00	3.80	3.80	25.74	27.07	36.00	36.00	Pass
HT20	MCS0	1	11	2462	22.25	22.31		30.00	30.00	3.80	3.80	26.05	26.11	36.00	36.00	Pass
HT40	MCS0	1	3	2422	21.44	21.64		30.00	30.00	3.80	3.80	25.24	25.44	36.00	36.00	Pass
HT40	MCS0	1	6	2437	22.08	23.30		30.00	30.00	3.80	3.80	25.88	27.10	36.00	36.00	Pass
HT40	MCS0	1	9	2452	20.75	20.64		30.00	30.00	3.80	3.80	24.55	24.44	36.00	36.00	Pass
HT20	MCS8	2	1	2412	22.29	23.02	25.68	30.00		3.80		29.48		36.00		Pass
HT20	MCS8	2	6	2437	22.14	24.35	26.39	30.00		3.80		30.19		36.00		Pass
HT20	MCS8	2	11	2462	22.31	22.60	25.47	30.00		3.80		29.27		36.00		Pass
HT40	MCS8	2	3	2422	21.24	22.06	24.68	30.00		3.80		28.48		36.00		Pass
HT40	MCS8	2	6	2437	22.51	24.20	26.45	30.00		3.80		30.25		36.00		Pass
HT40	MCS8	2	9	2452	20.62	21.30	23.98	30.00		3.80		27.78		36.00		Pass

Note: Measured power (dBm) has offset with cable loss.

**TEST RESULTS DATA**  
**Average Output Power**

2.4GHz Band									
Mod.	Data Rate	N <sub>TX</sub>	CH.	Freq. (MHz)	Duty Factor (dB)		Average Conducted Power (dBm)		
					Ant 1	Ant 2	Ant 1	Ant 2	SUM
11b	1Mbps	1	1	2412	0.12	0.10	14.42	14.16	
11b	1Mbps	1	6	2437	0.12	0.10	12.83	11.75	
11b	1Mbps	1	11	2462	0.12	0.10	13.72	12.70	
11g	6Mbps	1	1	2412	0.62	0.56	16.12	14.86	
11g	6Mbps	1	6	2437	0.62	0.56	14.57	12.74	
11g	6Mbps	1	11	2462	0.62	0.56	17.34	14.59	
HT20	MCS0	1	1	2412	0.66	0.60	14.72	14.69	
HT20	MCS0	1	6	2437	0.66	0.60	14.87	15.59	
HT20	MCS0	1	11	2462	0.66	0.60	15.56	14.35	
HT40	MCS0	1	3	2422	1.13	1.38	13.65	13.40	
HT40	MCS0	1	6	2437	1.13	1.38	15.52	16.05	
HT40	MCS0	1	9	2452	1.13	1.38	12.43	12.23	
HT20	MCS8	2	1	2412	0.66	0.66	14.85	14.60	17.74
HT20	MCS8	2	6	2437	0.66	0.66	14.61	16.44	18.63
HT20	MCS8	2	11	2462	0.66	0.66	16.16	14.86	18.57
HT40	MCS8	2	3	2422	1.18	1.20	13.38	13.70	16.56
HT40	MCS8	2	6	2437	1.18	1.20	15.58	16.60	19.13
HT40	MCS8	2	9	2452	1.18	1.20	12.63	12.23	15.45

Note: Measured power (dBm) has offset with cable loss.

**TEST RESULTS DATA**  
**Peak Power Spectral Density**

2.4GHz Band												
Mod.	Data Rate	NTX	CH.	Freq. (MHz)	Peak PSD (dBm/3kHz)			DG (dBi)		Peak PSD Limit (dBm/3kHz)		Pass/Fail
					Ant 1	Ant 2	Worse + 3.01	Ant 1	Ant 2	Ant 1	Ant 2	
11b	1Mbps	1	1	2412	-11.37		-	3.80	3.80	8.00	8.00	Pass
11b	1Mbps	1	6	2437	-11.96			3.80	3.80	8.00	8.00	Pass
11b	1Mbps	1	11	2462	-11.88			3.80	3.80	8.00	8.00	Pass
11g	6Mbps	1	1	2412	-10.70			3.80	3.80	8.00	8.00	Pass
11g	6Mbps	1	6	2437	-12.64			3.80	3.80	8.00	8.00	Pass
11g	6Mbps	1	11	2462	-11.77			3.80	3.80	8.00	8.00	Pass
HT20	MCS8	2	1	2412	-13.28	-12.57	-9.56	3.80		8.00		Pass
HT20	MCS8	2	6	2437	-13.42	-11.81	-8.80	3.80		8.00		Pass
HT20	MCS8	2	11	2462	-12.21	-13.05	-9.20	3.80		8.00		Pass
HT40	MCS8	2	3	2422	-16.28	-15.15	-12.14	3.80		8.00		Pass
HT40	MCS8	2	6	2437	-15.01	-14.10	-11.09	3.80		8.00		Pass
HT40	MCS8	2	9	2452	-17.83	-17.52	-14.51	3.80		8.00		Pass

Measured power density (dBm) has offset with cable loss.



## Appendix B. Radiated Spurious Emission

Test Engineer :	Peter Liao, Karl Hou, and Nick Yu	Temperature :	21~24°C
		Relative Humidity :	56~59%

### 2.4GHz 2400~2483.5MHz

#### WIFI 802.11b (Band Edge @ 3m)

WIFI	Note	Frequency	Level	Over	Limit	Read	Antenna	Cable	Preamp	Ant	Table	Peak	Pol.	
Ant.				Limit	Line	Level	Factor	Loss	Factor	Pos	Pos	Avg.		
1		( MHz )	( dBμV/m )	( dB )	( dBμV/m )	( dBμV )	( dB/m )	( dB )	( dB )	( cm )	( deg )	( P/A )	( H/V )	
802.11b CH 01 2412MHz		2386.965	60.56	-13.44	74	57.55	27.05	7.45	31.49	190	238	P	H	
		2390	51.21	-2.79	54	48.2	27.05	7.45	31.49	190	238	A	H	
	*	2412	104.73	-	-	101.68	27.09	7.45	31.49	190	238	P	H	
	*	2410	100.63	-	-	97.58	27.09	7.45	31.49	190	238	A	H	
													H	
														H
			2386.965	61.09	-12.91	74	58.08	27.05	7.45	31.49	370	279	P	V
			2390	53.11	-0.89	54	50.1	27.05	7.45	31.49	370	279	A	V
	*		2412	107.1	-	-	104.05	27.09	7.45	31.49	370	279	P	V
	*		2410	102.91	-	-	99.86	27.09	7.45	31.49	370	279	A	V
														V
														V
802.11b CH 06 2437MHz		2381.12	56.08	-17.92	74	53.11	27.01	7.45	31.49	186	239	P	H	
		2387.56	44.3	-9.7	54	41.29	27.05	7.45	31.49	186	239	A	H	
	*	2437	99.94	-	-	96.75	27.18	7.49	31.48	186	239	P	H	
	*	2437	96.23	-	-	93.04	27.18	7.49	31.48	186	239	A	H	
			2484.18	56.56	-17.44	74	53.24	27.26	7.53	31.47	186	239	P	H
			2497.97	44.47	-9.53	54	41.1	27.3	7.53	31.46	186	239	A	H
			2377.34	55.5	-18.5	74	52.61	27.01	7.37	31.49	330	282	P	V
			2387.56	44.1	-9.9	54	41.09	27.05	7.45	31.49	330	282	A	V
	*		2437	103.13	-	-	99.94	27.18	7.49	31.48	330	282	P	V
	*		2437	99.4	-	-	96.21	27.18	7.49	31.48	330	282	A	V
			2498.46	56.4	-17.6	74	53.03	27.3	7.53	31.46	330	282	P	V
			2494.05	44.43	-9.57	54	41.06	27.3	7.53	31.46	330	282	A	V





<b>802.11b</b> <b>CH 11</b> <b>2462MHz</b>	*	2462	99.52	-	-	96.24	27.22	7.53	31.47	215	185	P	H
	*	2460	95.22	-	-	91.98	27.22	7.49	31.47	215	185	A	H
		2485.76	56.72	-17.28	74	53.4	27.26	7.53	31.47	215	185	P	H
		2489.24	44.49	-9.51	54	41.13	27.3	7.53	31.47	215	185	A	H
													H
													H
	*	2462	100.84	-	-	97.56	27.22	7.53	31.47	386	280	P	V
	*	2460	96.67	-	-	93.43	27.22	7.49	31.47	386	280	A	V
		2495.88	56.02	-17.98	74	52.65	27.3	7.53	31.46	386	280	P	V
		2495.64	44.43	-9.57	54	41.06	27.3	7.53	31.46	386	280	A	V
													V
													V
<b>Remark</b>	1. No other spurious found. 2. All results are PASS against Peak and Average limit line.												



**2.4GHz 2400~2483.5MHz  
WIFI 802.11b (Harmonic @ 3m)**

WIFI Ant. 1	Note	Frequency ( MHz )	Level ( dBμV/m )	Over Limit ( dB )	Limit Line ( dBμV/m )	Read Level ( dBμV )	Antenna Factor ( dB/m )	Cable Loss ( dB )	Preamp Factor ( dB )	Ant Pos ( cm )	Table Pos ( deg )	Peak Avg. (P/A)	Pol. (H/V)	
802.11b CH 01 2412MHz		4824	51.24	-22.76	74	67.38	31.26	10.74	58.14	100	0	P	H	
													H	
													H	
													H	
			4824	55.27	-18.73	74	71.41	31.26	10.74	58.14	385	204	P	V
			4824	53.38	-0.62	54	69.52	31.26	10.74	58.14	385	204	A	V
														V
802.11b CH 06 2437MHz		4874	49.79	-24.21	74	65.67	31.33	10.89	58.1	100	0	P	H	
		7311	50.86	-23.14	74	59.7	36.07	14.18	59.09	100	0	P	H	
													H	
													H	
			4874	51.98	-22.02	74	67.86	31.33	10.89	58.1	100	0	P	V
			7311	57.42	-16.58	74	66.26	36.07	14.18	59.09	351	212	P	V
			7311	53.38	-0.62	54	62.22	36.07	14.18	59.09	351	212	A	V
802.11b CH 11 2462MHz		4924	51.42	-22.58	74	67.04	31.4	11.04	58.06	100	0	P	H	
		7386	49.81	-24.19	74	58.37	36.31	14.27	59.14	100	0	P	H	
													H	
													H	
			4924	49.8	-24.2	74	65.42	31.4	11.04	58.06	100	0	P	V
			7386	56.94	-17.06	74	65.5	36.31	14.27	59.14	353	209	P	V
			7386	52.77	-1.23	54	61.33	36.31	14.27	59.14	353	209	A	V
													V	
Remark	1. No other spurious found. 2. All results are PASS against Peak and Average limit line.													



**2.4GHz 2400~2483.5MHz  
WIFI 802.11g (Band Edge @ 3m)**

WIFI Ant. 1	Note	Frequency ( MHz )	Level ( dBμV/m )	Over Limit ( dB )	Limit Line ( dBμV/m )	Read Level ( dBμV )	Antenna Factor ( dB/m )	Cable Loss ( dB )	Preamp Factor ( dB )	Ant Pos ( cm )	Table Pos ( deg )	Peak Avg. ( P/A )	Pol. ( H/V )	
802.11g CH 01 2412MHz		2389.17	63.78	-10.22	74	60.77	27.05	7.45	31.49	117	257	P	H	
		2390	50.82	-3.18	54	47.81	27.05	7.45	31.49	117	257	A	H	
	*	2412	104.46	-	-	101.41	27.09	7.45	31.49	117	257	P	H	
	*	2412	94.94	-	-	91.89	27.09	7.45	31.49	117	257	A	H	
													H	
														H
			2389.8	66.73	-7.27	74	63.72	27.05	7.45	31.49	337	265	P	V
			2389.905	52.31	-1.69	54	49.3	27.05	7.45	31.49	337	265	A	V
	*		2412	107.21	-	-	104.16	27.09	7.45	31.49	337	265	P	V
	*		2412	97.45	-	-	94.4	27.09	7.45	31.49	337	265	A	V
														V
														V
802.11g CH 06 2437MHz		2374.26	56.13	-17.87	74	53.24	27.01	7.37	31.49	100	56	P	H	
		2388.68	44.52	-9.48	54	41.51	27.05	7.45	31.49	100	56	A	H	
	*	2446	104.49	-	-	101.29	27.18	7.49	31.47	100	56	P	H	
	*	2444	95.88	-	-	92.68	27.18	7.49	31.47	100	56	A	H	
			2495.24	56.01	-17.99	74	52.64	27.3	7.53	31.46	100	56	P	H
			2495.17	44.94	-9.06	54	41.57	27.3	7.53	31.46	100	56	A	H
			2339.68	55.94	-18.06	74	53.21	26.93	7.3	31.5	379	278	P	V
			2376.36	44.62	-9.38	54	41.73	27.01	7.37	31.49	379	278	A	V
	*		2446	108.2	-	-	105	27.18	7.49	31.47	379	278	P	V
	*		2444	99.15	-	-	95.95	27.18	7.49	31.47	379	278	A	V
			2496.29	55.59	-18.41	74	52.22	27.3	7.53	31.46	379	278	P	V
			2483.83	44.93	-9.07	54	41.61	27.26	7.53	31.47	379	278	A	V



<b>802.11g CH 11 2462MHz</b>	*	2462	105.26	-	-	101.98	27.22	7.53	31.47	158	187	P	H
	*	2462	95.05	-	-	91.77	27.22	7.53	31.47	158	187	A	H
		2484.04	65.73	-8.27	74	62.41	27.26	7.53	31.47	158	187	P	H
		2483.56	51.85	-2.15	54	48.53	27.26	7.53	31.47	158	187	A	H
													H
													H
	*	2462	106.27	-	-	102.99	27.22	7.53	31.47	326	265	P	V
	*	2462	96.7	-	-	93.42	27.22	7.53	31.47	326	265	A	V
		2484	65.04	-8.96	74	61.72	27.26	7.53	31.47	326	265	P	V
		2483.52	51.86	-2.14	54	48.54	27.26	7.53	31.47	326	265	A	V
													V
													V
<b>Remark</b>	1. No other spurious found. 2. All results are PASS against Peak and Average limit line.												



**2.4GHz 2400~2483.5MHz**  
**WIFI 802.11g (Harmonic @ 3m)**

WIFI Ant. 1	Note	Frequency ( MHz )	Level ( dBμV/m )	Over Limit ( dB )	Limit Line ( dBμV/m )	Read Level ( dBμV )	Antenna Factor ( dB/m )	Cable Loss ( dB )	Preamp Factor ( dB )	Ant Pos ( cm )	Table Pos ( deg )	Peak Avg. ( P/A )	Pol. ( H/V )	
802.11g CH 01 2412MHz		4824	49.92	-24.08	74	66.06	31.26	10.74	58.14	100	0	P	H	
													H	
													H	
													H	
			4824	57.22	-16.78	74	73.36	31.26	10.74	58.14	321	206	P	V
			4824	43.75	-10.25	54	59.89	31.26	10.74	58.14	321	206	A	V
														V
802.11g CH 06 2437MHz		4874	46.99	-27.01	74	62.87	31.33	10.89	58.1	100	0	P	H	
		7311	58.71	-15.29	74	67.55	36.07	14.18	59.09	317	317	P	H	
		7311	44.99	-9.01	54	53.83	36.07	14.18	59.09	317	317	A	H	
													H	
			4874	51.55	-22.45	74	67.43	31.33	10.89	58.1	100	0	P	V
			7311	66.68	-7.32	74	75.52	36.07	14.18	59.09	351	211	P	V
			7311	52.78	-1.22	54	61.62	36.07	14.18	59.09	351	211	A	V
802.11g CH 11 2462MHz		4924	51.4	-22.6	74	67.02	31.4	11.04	58.06	100	0	P	H	
		7386	58.61	-15.39	74	67.17	36.31	14.27	59.14	304	292	P	H	
		7386	46.09	-7.91	54	54.65	36.31	14.27	59.14	304	292	A	H	
													H	
			4924	49.93	-24.07	74	65.55	31.4	11.04	58.06	100	0	P	V
			7386	67.39	-6.61	74	75.95	36.31	14.27	59.14	355	208	P	V
			7386	53.46	-0.54	54	62.02	36.31	14.27	59.14	355	208	A	V
													V	
Remark	1. No other spurious found. 2. All results are PASS against Peak and Average limit line.													



2.4GHz 2400~2483.5MHz

Emission below 1GHz

2.4GHz WIFI 802.11g (LF)

WIFI Ant.	Note	Frequency	Level	Over Limit	Limit Line	Read Level	Antenna Factor	Cable Loss	Preamp Factor	Ant Pos	Table Pos	Peak Avg.	Pol.	
1		( MHz )	( dBμV/m )	( dB )	( dBμV/m )	( dBμV )	( dB/m )	( dB )	( dB )	( cm )	( deg )	( P/A )	( H/V )	
2.4GHz 802.11g LF		190.38	32.18	-11.32	43.5	47.59	15.3	1.7	32.41			P	H	
		209.28	34.13	-9.37	43.5	48.75	16.07	1.7	32.39			P	H	
		248.7	36.77	-9.23	46	48.92	18.34	1.83	32.32	100	0	P	H	
		309.8	35.2	-10.8	46	45.31	19.79	2.34	32.24			P	H	
		483.4	29.19	-16.81	46	34.81	23.69	3.08	32.39			P	H	
		948.9	31.86	-14.14	46	27.98	30.27	4.75	31.14			P	H	
														H
														H
														H
														H
														H
														H
			39.99	36.97	-3.03	40	48.35	20.3	0.78	32.46	100	255	QP	V
		*	39.99	40.35	0.35	40	51.73	20.3	0.78	32.46	100	255	P	V
			99.66	34.06	-9.44	43.5	49.43	16	1.06	32.43			P	V
			258.69	32.31	-13.69	46	43.38	19.4	1.83	32.3			P	V
			309.8	31.92	-14.08	46	42.03	19.79	2.34	32.24			P	V
			435.1	31.45	-14.55	46	38.1	22.84	2.89	32.38			P	V
			483.4	36.43	-9.57	46	42.05	23.69	3.08	32.39			P	V
														V
													V	
													V	
													V	
													V	
Remark	1. No other spurious found. 2. All results are PASS against limit line.													



**Note symbol**

*	<b>Fundamental Frequency</b> which can be ignored. However, the level of any unwanted emissions shall not exceed the level of the fundamental frequency.
!	Test result is <b>over limit</b> line.
P/A	<b>Peak</b> or <b>Average</b>
H/V	<b>Horizontal</b> or <b>Vertical</b>



A calculation example for radiated spurious emission is shown as below:

WIFI	Note	Frequency	Level	Over	Limit	Read	Antenna	Cable	Preamp	Ant	Table	Peak	Pol.
Ant.				Limit	Line	Level	Factor	Loss	Factor	Pos	Pos	Avg.	
1		( MHz )	( dBμV/m )	( dB )	( dBμV/m )	( dBμV )	( dB/m )	( dB )	( dB )	( cm )	( deg )	( P/A )	( H/V )
802.11b		2390	55.45	-18.55	74	54.51	32.22	4.58	35.86	103	308	P	H
CH 01													
2412MHz		2390	43.54	-10.46	54	42.6	32.22	4.58	35.86	103	308	A	H

- Level(dBμV/m) =  
Antenna Factor(dB/m) + Cable Loss(dB) + Read Level(dBμV) - Preamp Factor(dB)
- Over Limit(dB) = Level(dBμV/m) – Limit Line(dBμV/m)

**For Peak Limit @ 2390MHz:**

- Level(dBμV/m)  
= Antenna Factor(dB/m) + Cable Loss(dB) + Read Level(dBμV) - Preamp Factor(dB)  
= 32.22(dB/m) + 4.58(dB) + 54.51(dBμV) – 35.86 (dB)  
= 55.45 (dBμV/m)
- Over Limit(dB)  
= Level(dBμV/m) – Limit Line(dBμV/m)  
= 55.45(dBμV/m) – 74(dBμV/m)  
= -18.55(dB)

**For Average Limit @ 2390MHz:**

- Level(dBμV/m)  
= Antenna Factor(dB/m) + Cable Loss(dB) + Read Level(dBμV) - Preamp Factor(dB)  
= 32.22(dB/m) + 4.58(dB) + 42.6(dBμV) – 35.86 (dB)  
= 43.54 (dBμV/m)
- Over Limit(dB)  
= Level(dBμV/m) – Limit Line(dBμV/m)  
= 43.54(dBμV/m) – 54(dBμV/m)  
= -10.46(dB)

Both peak and average measured complies with the limit line, so test result is “PASS”.





2.4GHz 2400~2483.5MHz

WIFI 802.11n HT20 (Band Edge @ 3m)

WIFI	Note	Frequency	Level	Over	Limit	Read	Antenna	Cable	Preamp	Ant	Table	Peak	Pol.	
Ant.				Limit	Line	Level	Factor	Loss	Factor	Pos	Pos	Avg.		
1+2		( MHz )	( dBμV/m )	( dB )	( dBμV/m )	( dBμV )	( dB/m )	( dB )	( dB )	( cm )	( deg )	(P/A)	(H/V)	
802.11n HT20 CH 01 2412MHz		2389.065	69.98	-4.02	74	66.97	27.05	7.45	31.49	310	180	P	H	
		2390	53.09	-0.91	54	50.08	27.05	7.45	31.49	310	180	A	H	
	*	2412	108.55	-	-	105.5	27.09	7.45	31.49	310	180	P	H	
	*	2412	98.28	-	-	95.23	27.09	7.45	31.49	310	180	A	H	
													H	
														H
	802.11n HT20 CH 06 2437MHz		2350.04	55.7	-18.3	74	52.9	26.93	7.37	31.5	211	186	P	H
		2386.86	45.78	-8.22	54	42.77	27.05	7.45	31.49	211	186	A	H	
*		2437	107.99	-	-	104.8	27.18	7.49	31.48	211	186	P	H	
*		2437	98.99	-	-	95.8	27.18	7.49	31.48	211	186	A	H	



<b>802.11n HT20 CH 11 2462MHz</b>	*	2462	107.94	-	-	104.66	27.22	7.53	31.47	269	166	P	H
	*	2462	97.7	-	-	94.42	27.22	7.53	31.47	269	166	A	H
		2484.6	66.8	-7.2	74	63.48	27.26	7.53	31.47	269	166	P	H
		2483.68	52.63	-1.37	54	49.31	27.26	7.53	31.47	269	166	A	H
													H
													H
	*	2462	107.3	-	-	104.02	27.22	7.53	31.47	378	279	P	V
	*	2462	97.92	-	-	94.64	27.22	7.53	31.47	378	279	A	V
		2483.72	64.88	-9.12	74	61.56	27.26	7.53	31.47	378	279	P	V
		2483.52	51.56	-2.44	54	48.24	27.26	7.53	31.47	378	279	A	V
												V	
												V	
<b>Remark</b>	1. No other spurious found. 2. All results are PASS against Peak and Average limit line.												



**2.4GHz 2400~2483.5MHz  
WIFI 802.11n HT20 (Harmonic @ 3m)**

WIFI Ant. 1+2	Note	Frequency ( MHz )	Level ( dBμV/m )	Over Limit ( dB )	Limit Line ( dBμV/m )	Read Level ( dBμV )	Antenna Factor ( dB/m )	Cable Loss ( dB )	Preamp Factor ( dB )	Ant Pos ( cm )	Table Pos ( deg )	Peak Avg. ( P/A )	Pol. ( H/V )	
802.11n HT20 CH 01 2412MHz		4824	60.26	-13.74	74	76.4	31.26	10.74	58.14	385	308	P	H	
		4824	46.54	-7.46	54	62.68	31.26	10.74	58.14	385	308	A	H	
													H	
													H	
			4824	62.46	-11.54	74	78.6	31.26	10.74	58.14	330	209	P	V
			4824	49.84	-4.16	54	65.98	31.26	10.74	58.14	330	209	A	V
														V
802.11n HT20 CH 06 2437MHz		4872	60.41	-13.59	74	76.29	31.33	10.89	58.1	121	303	P	H	
		4872	48.19	-5.81	54	64.07	31.33	10.89	58.1	121	303	A	H	
		7311	61.13	-12.87	74	69.97	36.07	14.18	59.09	303	253	P	H	
		7311	45.85	-8.15	54	54.69	36.07	14.18	59.09	303	253	A	H	
		4874	63.64	-10.36	74	79.52	31.33	10.89	58.1	375	213	P	V	
		4874	50.62	-3.38	54	66.5	31.33	10.89	58.1	375	213	A	V	
		7311	67.98	-6.02	74	76.82	36.07	14.18	59.09	377	209	P	V	
802.11n HT20 CH 11 2462MHz		7311	53.15	-0.85	54	61.99	36.07	14.18	59.09	377	209	A	V	
		4926	63.06	-10.94	74	78.68	31.4	11.04	58.06	392	307	P	H	
		4926	50.14	-3.86	54	65.76	31.4	11.04	58.06	392	307	A	H	
		7386	62.73	-11.27	74	71.29	36.31	14.27	59.14	365	253	P	H	
		7386	46.38	-7.62	54	54.94	36.31	14.27	59.14	365	253	A	H	
		4924	64.94	-9.06	74	80.56	31.4	11.04	58.06	388	214	P	V	
		4924	51.52	-2.48	54	67.14	31.4	11.04	58.06	388	214	A	V	
Remark		7386	68.87	-5.13	74	77.43	36.31	14.27	59.14	379	206	P	V	
		7386	52.86	-1.14	54	61.42	36.31	14.27	59.14	379	206	A	V	

1. No other spurious found.  
2. All results are PASS against Peak and Average limit line.



**2.4GHz 2400~2483.5MHz  
WIFI 802.11n HT40 (Band Edge @ 3m)**

WIFI Ant. 1+2	Note	Frequency ( MHz )	Level ( dBμV/m )	Over Limit ( dB )	Limit Line ( dBμV/m )	Read Level ( dBμV )	Antenna Factor ( dB/m )	Cable Loss ( dB )	Preamp Factor ( dB )	Ant Pos ( cm )	Table Pos ( deg )	Peak Avg. ( P/A )	Pol. ( H/V )
802.11n HT40 CH 03 2422MHz		2386.44	66.91	-7.09	74	63.9	27.05	7.45	31.49	337	182	P	H
		2389.52	53.17	-0.83	54	50.16	27.05	7.45	31.49	337	182	A	H
	*	2422	104.3	-	-	101.16	27.13	7.49	31.48	337	182	P	H
	*	2422	94.01	-	-	90.87	27.13	7.49	31.48	337	182	A	H
		2484.88	56.09	-17.91	74	52.77	27.26	7.53	31.47	337	182	P	H
		2485.3	45.86	-8.14	54	42.54	27.26	7.53	31.47	337	182	A	H
		2386.86	66.34	-7.66	74	63.33	27.05	7.45	31.49	323	277	P	V
		2389.8	51.17	-2.83	54	48.16	27.05	7.45	31.49	323	277	A	V
	*	2422	103.83	-	-	100.69	27.13	7.49	31.48	323	277	P	V
	*	2422	93.76	-	-	90.62	27.13	7.49	31.48	323	277	A	V
		2493.14	56.65	-17.35	74	53.28	27.3	7.53	31.46	323	277	P	V
		2499.72	45.47	-8.53	54	42.1	27.3	7.53	31.46	323	277	A	V
802.11n HT40 CH 06 2437MHz		2387.84	66.69	-7.31	74	63.68	27.05	7.45	31.49	347	183	P	H
		2389.94	52.49	-1.51	54	49.48	27.05	7.45	31.49	347	183	A	H
	*	2437	107.38	-	-	104.19	27.18	7.49	31.48	347	183	P	H
	*	2437	96.54	-	-	93.35	27.18	7.49	31.48	347	183	A	H
		2484.74	66.39	-7.61	74	63.07	27.26	7.53	31.47	347	183	P	H
		2483.97	51.25	-2.75	54	47.93	27.26	7.53	31.47	347	183	A	H
		2389.66	60.1	-13.9	74	57.09	27.05	7.45	31.49	300	276	P	V
		2389.94	48.89	-5.11	54	45.88	27.05	7.45	31.49	300	276	A	V
	*	2437	106.86	-	-	103.67	27.18	7.49	31.48	300	276	P	V
	*	2437	96.71	-	-	93.52	27.18	7.49	31.48	300	276	A	V
	2484.53	62.23	-11.77	74	58.91	27.26	7.53	31.47	300	276	P	V	
	2483.69	50.42	-3.58	54	47.1	27.26	7.53	31.47	300	276	A	V	



<b>802.11n</b>  <b>HT40</b>  <b>CH 09</b>  <b>2452MHz</b>		2374.12	55.59	-18.41	74	52.7	27.01	7.37	31.49	174	184	P	H
		2364.46	45.37	-8.63	54	42.52	26.97	7.37	31.49	174	184	A	H
	*	2452	103.42	-	-	100.22	27.18	7.49	31.47	174	184	P	H
	*	2452	93.27	-	-	90.07	27.18	7.49	31.47	174	184	A	H
		2484.04	66.61	-7.39	74	63.29	27.26	7.53	31.47	174	184	P	H
		2483.62	53.3	-0.7	54	49.98	27.26	7.53	31.47	174	184	A	H
		2366.98	57.03	-16.97	74	54.18	26.97	7.37	31.49	302	275	P	V
		2377.9	45.34	-8.66	54	42.45	27.01	7.37	31.49	302	275	A	V
	*	2452	103.73	-	-	100.53	27.18	7.49	31.47	302	275	P	V
	*	2452	94.23	-	-	91.03	27.18	7.49	31.47	302	275	A	V
		2485.02	62.93	-11.07	74	59.61	27.26	7.53	31.47	302	275	P	V
		2483.5	50.67	-3.33	54	47.35	27.26	7.53	31.47	302	275	A	V
<b>Remark</b>	1. No other spurious found. 2. All results are PASS against Peak and Average limit line.												



**2.4GHz 2400~2483.5MHz  
WIFI 802.11n HT40 (Harmonic @ 3m)**

WIFI Ant. 1+2	Note	Frequency ( MHz )	Level ( dBμV/m )	Over Limit ( dB )	Limit Line ( dBμV/m )	Read Level ( dBμV )	Antenna Factor ( dB/m )	Cable Loss ( dB )	Preamp Factor ( dB )	Ant Pos ( cm )	Table Pos ( deg )	Peak Avg. ( P/A )	Pol. ( H/V )
802.11n HT40 CH 03 2422MHz		4842	56.69	-17.31	74	72.79	31.28	10.74	58.12	100	301	P	H
		4842	41.93	-12.07	54	58.03	31.28	10.74	58.12	100	301	A	H
		7266	58.76	-15.24	74	67.72	35.97	14.14	59.07	298	256	P	H
		7266	40.92	-13.08	54	49.88	35.97	14.14	59.07	298	256	A	H
		4844	59.4	-14.6	74	75.5	31.28	10.74	58.12	323	213	P	V
		4844	45.87	-8.13	54	61.97	31.28	10.74	58.12	323	213	A	V
		7266	63.3	-10.7	74	72.26	35.97	14.14	59.07	387	208	P	V
		7266	46.57	-7.43	54	55.53	35.97	14.14	59.07	387	208	A	V
802.11n HT40 CH 06 2437MHz		4874	58.41	-15.59	74	74.29	31.33	10.89	58.1	121	304	P	H
		4874	44.7	-9.3	54	60.58	31.33	10.89	58.1	121	304	A	H
		7311	61.47	-12.53	74	70.31	36.07	14.18	59.09	397	219	P	H
		7311	44.62	-9.38	54	53.46	36.07	14.18	59.09	397	219	A	H
		4874	62.15	-11.85	74	78.03	31.33	10.89	58.1	313	222	P	V
		4874	47.92	-6.08	54	63.8	31.33	10.89	58.1	313	222	A	V
		7311	67.16	-6.84	74	76	36.07	14.18	59.09	386	211	P	V
		7311	51.1	-2.9	54	59.94	36.07	14.18	59.09	386	211	A	V
802.11n HT40 CH 09 2452MHz		4904	57.36	-16.64	74	73.01	31.38	11.04	58.07	100	303	P	H
		4904	42.73	-11.27	54	58.38	31.38	11.04	58.07	100	303	A	H
		7356	56.86	-17.14	74	65.55	36.21	14.22	59.12	395	220	P	H
		7356	41.49	-12.51	54	50.18	36.21	14.22	59.12	395	220	A	H
		4904	61.14	-12.86	74	76.79	31.38	11.04	58.07	345	213	P	V
		4904	46.69	-7.31	54	62.34	31.38	11.04	58.07	345	213	A	V
		7356	63.81	-10.19	74	72.5	36.21	14.22	59.12	392	208	P	V
		7356	48.24	-5.76	54	56.93	36.21	14.22	59.12	392	208	A	V
Remark	1. No other spurious found. 2. All results are PASS against Peak and Average limit line.												



2.4GHz 2400~2483.5MHz

Emission below 1GHz

2.4GHz WIFI 802.11n HT40 (LF)

WIFI Ant.	Note	Frequency	Level	Over Limit	Limit Line	Read Level	Antenna Factor	Cable Loss	Preamp Factor	Ant Pos	Table Pos	Peak Avg.	Pol.	
1+2		( MHz )	( dBμV/m )	( dB )	( dBμV/m )	( dBμV )	( dB/m )	( dB )	( dB )	( cm )	( deg )	( P/A )	( H/V )	
2.4GHz 802.11n HT40 LF		170.4	33	-10.5	43.5	47.82	15.85	1.75	32.42			P	H	
		204.42	33.84	-9.66	43.5	48.6	15.94	1.7	32.4			P	H	
		238.71	38.12	-7.88	46	51.12	17.51	1.83	32.34			P	H	
		313.3	34.88	-11.12	46	44.89	19.9	2.34	32.25			P	H	
		435.1	33.07	-12.93	46	39.72	22.84	2.89	32.38			P	H	
		746.6	38.28	-7.72	46	39.09	27.53	3.97	32.31	100	0	P	H	
														H
														H
														H
														H
														H
														H
														H
			39.72	36.67	-3.33	40	48.05	20.3	0.78	32.46	100	24	QP	V
		*	39.72	41.58	1.58	40	52.96	20.3	0.78	32.46	100	24	P	V
			61.05	34.14	-5.86	40	53.68	11.85	1.06	32.45			P	V
			115.32	36.56	-6.94	43.5	50.19	17.37	1.43	32.43			P	V
			483.4	33.32	-12.68	46	38.94	23.69	3.08	32.39			P	V
			860.7	31.34	-14.66	46	30.05	28.66	4.45	31.82			P	V
			934.2	33.74	-12.26	46	30.55	29.86	4.6	31.27			P	V
													V	
													V	
													V	
													V	
													V	
Remark	1. No other spurious found. 2. All results are PASS against limit line.													



**Note symbol**

*	<b>Fundamental Frequency</b> which can be ignored. However, the level of any unwanted emissions shall not exceed the level of the fundamental frequency.
!	Test result is <b>over limit</b> line.
P/A	<b>Peak</b> or <b>Average</b>
H/V	<b>Horizontal</b> or <b>Vertical</b>





A calculation example for radiated spurious emission is shown as below:

WIFI	Note	Frequency	Level	Over	Limit	Read	Antenna	Cable	Preamp	Ant	Table	Peak	Pol.
Ant.				Limit	Line	Level	Factor	Loss	Factor	Pos	Pos	Avg.	
1+2		( MHz )	( dBμV/m )	( dB )	( dBμV/m )	( dBμV )	( dB/m )	( dB )	( dB )	( cm )	( deg )	( P/A )	( H/V )
802.11b		2390	55.45	-18.55	74	54.51	32.22	4.58	35.86	103	308	P	H
CH 01													
2412MHz		2390	43.54	-10.46	54	42.6	32.22	4.58	35.86	103	308	A	H

- Level(dBμV/m) =  
Antenna Factor(dB/m) + Cable Loss(dB) + Read Level(dBμV) - Preamp Factor(dB)
- Over Limit(dB) = Level(dBμV/m) – Limit Line(dBμV/m)

**For Peak Limit @ 2390MHz:**

- Level(dBμV/m)  
= Antenna Factor(dB/m) + Cable Loss(dB) + Read Level(dBμV) - Preamp Factor(dB)  
= 32.22(dB/m) + 4.58(dB) + 54.51(dBμV) – 35.86 (dB)  
= 55.45 (dBμV/m)
- Over Limit(dB)  
= Level(dBμV/m) – Limit Line(dBμV/m)  
= 55.45(dBμV/m) – 74(dBμV/m)  
= -18.55(dB)

**For Average Limit @ 2390MHz:**

- Level(dBμV/m)  
= Antenna Factor(dB/m) + Cable Loss(dB) + Read Level(dBμV) - Preamp Factor(dB)  
= 32.22(dB/m) + 4.58(dB) + 42.6(dBμV) – 35.86 (dB)  
= 43.54 (dBμV/m)
- Over Limit(dB)  
= Level(dBμV/m) – Limit Line(dBμV/m)  
= 43.54(dBμV/m) – 54(dBμV/m)  
= -10.46(dB)

Both peak and average measured complies with the limit line, so test result is “PASS”.



## Appendix C. Radiated Spurious Emission Plots

<b>Test Engineer :</b>	Peter Liao, Karl Hou, and Nick Yu	<b>Temperature :</b>	21~24°C
		<b>Relative Humidity :</b>	56~59%

### Note symbol

-L	Low channel location
-R	High channel location

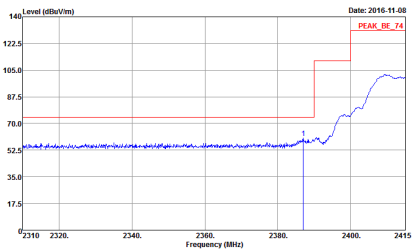
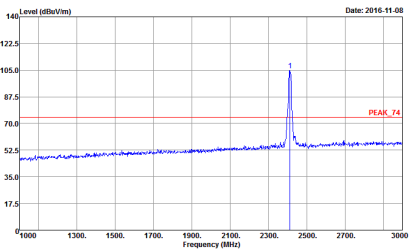
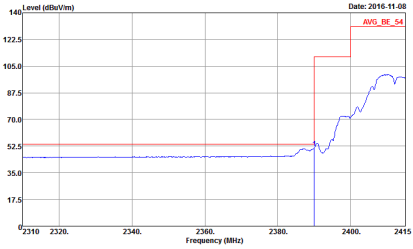
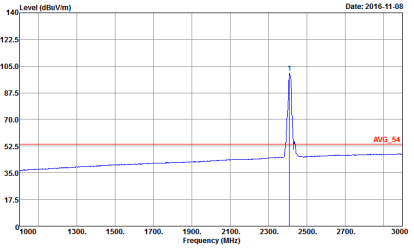

2.4GHz 2400~2483.5MHz  
WIFI 802.11b (Band Edge @ 3m)

WIFI	2.4GHz 2400~2483.5MHz Band Edge @ 3m	
ANT	802.11b CH01 2412MHz	
1	Horizontal	Fundamental
Peak	 <p>Site : 03CH12-HY Condition : PEAK_BE_74 3m HORN_9120D_1328 HORIZONTAL Detector : RBW:1000.000KHz VBW:3000.000KHz SWT:Auto Project : Peak Mode : 600550 Setting : 1  : 0B</p>	 <p>Site : 03CH12-HY Condition : PEAK_74 3m HORN_9120D_1328 HORIZONTAL Detector : RBW:1000.000KHz VBW:3000.000KHz SWT:Auto Project : Peak Mode : 600550 Setting : 1  : 0B</p>
Avg.	 <p>Site : 03CH12-HY Condition : AVG_BE_54 3m HORN_9120D_1328 HORIZONTAL Detector : RBW:1000.000KHz VBW:0.300KHz SWT:Auto Project : Peak Mode : 600550 Setting : 1  : 0B</p>	 <p>Site : 03CH12-HY Condition : AVG_54 3m HORN_9120D_1328 HORIZONTAL Detector : RBW:1000.000KHz VBW:0.300KHz SWT:Auto Project : Peak Mode : 600550 Setting : 1  : 0B</p>

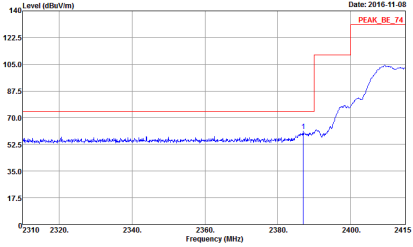
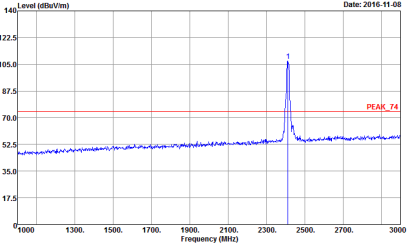
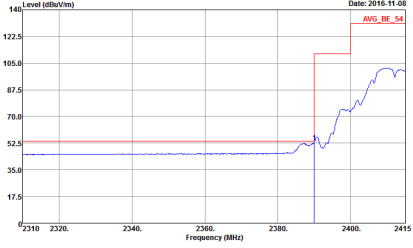
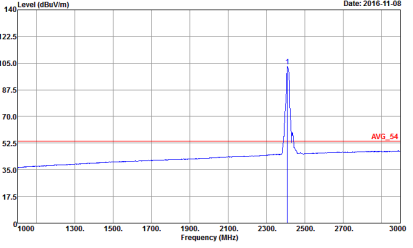

WIFI	2.4GHz 2400~2483.5MHz Band Edge @ 3m	
ANT	802.11b CH01 2412MHz	
1	Vertical	Fundamental
Peak	 <p>Site Condition : 03CH12-HY : PEAK_BE_74 3m HORN_9120D_1328 VERTICAL : RBW:1000.000kHz VBW:3000.000kHz SWT:Auto Detector : Peak Project : 600550 Mode : 1 Setting : 0B</p>	 <p>Site Condition : 03CH12-HY : PEAK_74 3m HORN_9120D_1328 VERTICAL : RBW:1000.000kHz VBW:3000.000kHz SWT:Auto Detector : Peak Project : 600550 Mode : 1 Setting : 0B</p>
Avg.	 <p>Site Condition : 03CH12-HY : AVG_BE_54 3m HORN_9120D_1328 VERTICAL : RBW:1000.000kHz VBW:0.300kHz SWT:Auto Detector : Peak Project : 600550 Mode : 1 Setting : 0B</p>	 <p>Site Condition : 03CH12-HY : AVG_54 3m HORN_9120D_1328 VERTICAL : RBW:1000.000kHz VBW:0.300kHz SWT:Auto Detector : Peak Project : 600550 Mode : 1 Setting : 0B</p>

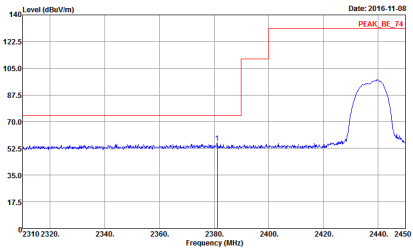
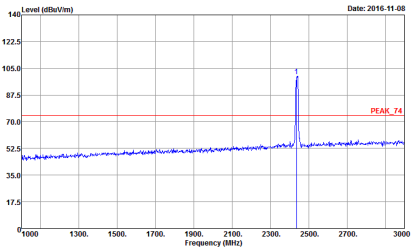
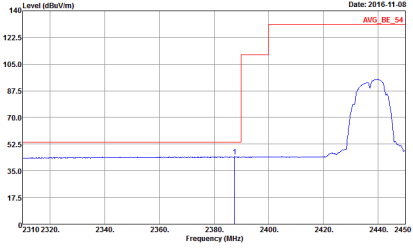
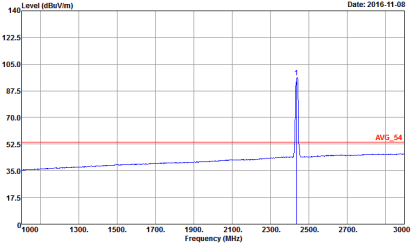

WIFI	2.4GHz 2400~2483.5MHz Band Edge @ 3m	
ANT	802.11b CH06 2437MHz - L	
1	<p style="text-align: center;"><b>Horizontal</b></p>  <p style="text-align: right;">Date: 2016-11-08 PEAK_BE_74</p> <p>Site Condition : 03CH12-HY : PEAK_BE_74 3m HORN_9120D_1328 HORIZONTAL : RBW:1000.000kHz VBW:3000.000kHz SWT:Auto Detector : Peak Project : 600550 Mode : 2 Setting : 09</p>	<p style="text-align: center;"><b>Fundamental</b></p>  <p style="text-align: right;">Date: 2016-11-08 PEAK_74</p> <p>Site Condition : 03CH12-HY : PEAK_74 3m HORN_9120D_1328 HORIZONTAL : RBW:1000.000kHz VBW:3000.000kHz SWT:Auto Detector : Peak Project : 600550 Mode : 2 Setting : 09</p>
Avg.	 <p style="text-align: right;">Date: 2016-11-08 AVG_BE_54</p> <p>Site Condition : 03CH12-HY : AVG_BE_54 3m HORN_9120D_1328 HORIZONTAL : RBW:1000.000kHz VBW:0.300kHz SWT:Auto Detector : Peak Project : 600550 Mode : 2 Setting : 09</p>	 <p style="text-align: right;">Date: 2016-11-08 AVG_54</p> <p>Site Condition : 03CH12-HY : AVG_54 3m HORN_9120D_1328 HORIZONTAL : RBW:1000.000kHz VBW:0.300kHz SWT:Auto Detector : Peak Project : 600550 Mode : 2 Setting : 09</p>

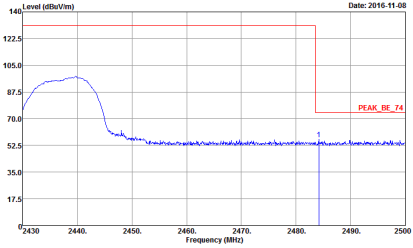
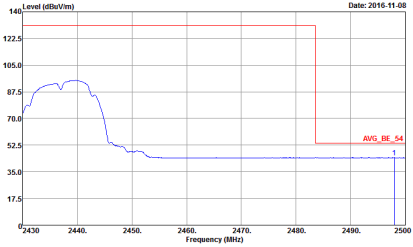

WIFI	2.4GHz 2400~2483.5MHz Band Edge @ 3m	
ANT	802.11b CH06 2437MHz - R	
1	Horizontal	Fundamental
Peak	 <p>Site : 03CH12-HY            Condition : PEAK_BE_74 3m HORN_9120D_1328 HORIZONTAL            : RBW:1000.000KHz VBW:3000.000KHz SWT:Auto            Detector : Peak            Project : 600550            Mode : 2            Setting : 09</p>	Left blank
Avg.	 <p>Site : 03CH12-HY            Condition : AVG_BE_54 3m HORN_9120D_1328 HORIZONTAL            : RBW:1000.000KHz VBW:0.300KHz SWT:Auto            Detector : Peak            Project : 600550            Mode : 2            Setting : 09</p>	Left blank

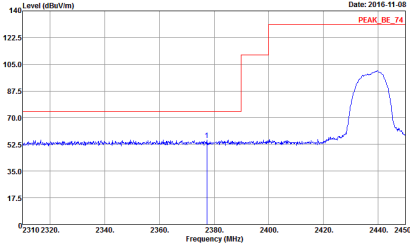
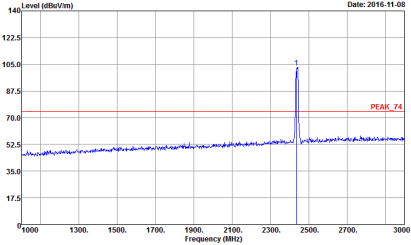
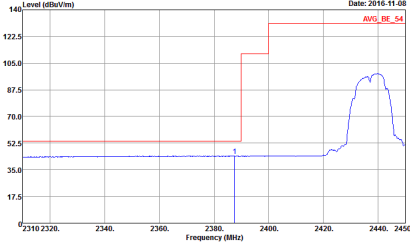
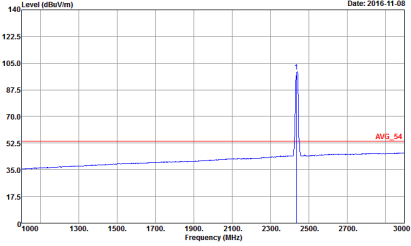

WIFI	2.4GHz 2400~2483.5MHz Band Edge @ 3m	
ANT	802.11b CH06 2437MHz - L	
<p style="text-align: center;"><b>1</b></p>	<p style="text-align: center;"><b>Vertical</b></p>  <p style="font-size: small;">Date: 2016-11-08 PEAK_BE_74</p> <p style="font-size: x-small;">Site Condition : 03CH12-HY : PEAK_BE_74 3m HORN_9120D_1328 VERTICAL : RBW:1000.000KHz VBW:3000.000KHz SWT:Auto Detector : Peak Project : 600550 Mode : 2 Setting : 09</p>	<p style="text-align: center;"><b>Fundamental</b></p>  <p style="font-size: small;">Date: 2016-11-08 PEAK_74</p> <p style="font-size: x-small;">Site Condition : 03CH12-HY : PEAK_74 3m HORN_9120D_1328 VERTICAL : RBW:1000.000KHz VBW:3000.000KHz SWT:Auto Detector : Peak Project : 600550 Mode : 2 Setting : 09</p>
<p style="text-align: center;"><b>Avg.</b></p>	 <p style="font-size: small;">Date: 2016-11-08 AVG_BE_54</p> <p style="font-size: x-small;">Site Condition : 03CH12-HY : AVG_BE_54 3m HORN_9120D_1328 VERTICAL : RBW:1000.000KHz VBW:0.300KHz SWT:Auto Detector : Peak Project : 600550 Mode : 2 Setting : 09</p>	 <p style="font-size: small;">Date: 2016-11-08 AVG_54</p> <p style="font-size: x-small;">Site Condition : 03CH12-HY : AVG_54 3m HORN_9120D_1328 VERTICAL : RBW:1000.000KHz VBW:0.300KHz SWT:Auto Detector : Peak Project : 600550 Mode : 2 Setting : 09</p>

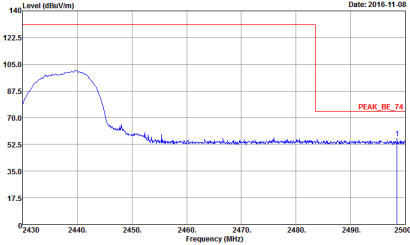
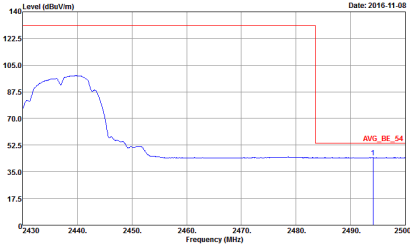

WIFI	2.4GHz 2400~2483.5MHz Band Edge @ 3m	
ANT	802.11b CH06 2437MHz - R	
1	Vertical	Fundamental
Peak	 <p>Date: 2016-11-08</p> <p>Site : 03CH12-HY  Condition : PEAK_BE_74 3m HORN_9120D_1328 VERTICAL  : RBW:1000.000KHz VBW:3000.000KHz SWT:Auto  Detector : Peak  Project : 600550  Mode : 2  Setting : 09</p>	Left blank
Avg.	 <p>Date: 2016-11-08</p> <p>Site : 03CH12-HY  Condition : AVG_BE_54 3m HORN_9120D_1328 VERTICAL  : RBW:1000.000KHz VBW:0.300KHz SWT:Auto  Detector : Peak  Project : 600550  Mode : 2  Setting : 09</p>	Left blank



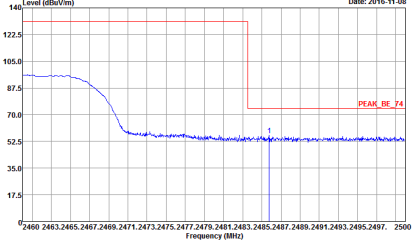
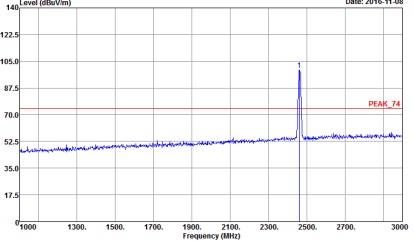
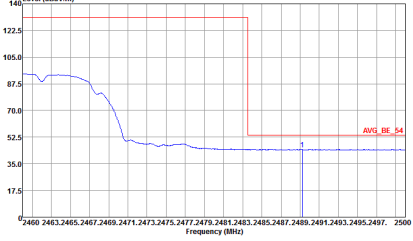
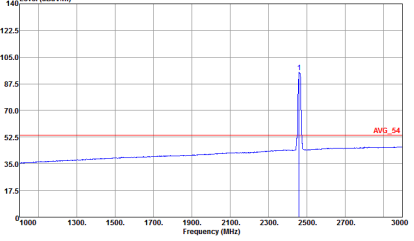

WIFI	2.4GHz 2400~2483.5MHz Band Edge @ 3m	
ANT	802.11b CH11 2462MHz	
1	<p style="text-align: center;"><b>Horizontal</b></p>  <p style="text-align: right;">Date: 2016-11-08</p> <p>Site Condition : 03CH12-HY            : PEAK_BE_74 3m HORN_9120D_1328 HORIZONTAL            : RBW:1000.000KHz VBW:3000.000KHz SWT:Auto            Detector : Peak            Project : 600550            Mode : 3            Setting : 08</p>	<p style="text-align: center;"><b>Fundamental</b></p>  <p style="text-align: right;">Date: 2016-11-08</p> <p>Site Condition : 03CH12-HY            : PEAK_74 3m HORN_9120D_1328 HORIZONTAL            : RBW:1000.000KHz VBW:3000.000KHz SWT:Auto            Detector : Peak            Project : 600550            Mode : 3            Setting : 08</p>
Avg.	 <p style="text-align: right;">Date: 2016-11-08</p> <p>Site Condition : 03CH12-HY            : AVG_BE_54 3m HORN_9120D_1328 HORIZONTAL            : RBW:1000.000KHz VBW:0.300KHz SWT:Auto            Detector : Peak            Project : 600550            Mode : 3            Setting : 08</p>	 <p style="text-align: right;">Date: 2016-11-08</p> <p>Site Condition : 03CH12-HY            : AVG_54 3m HORN_9120D_1328 HORIZONTAL            : RBW:1000.000KHz VBW:0.300KHz SWT:Auto            Detector : Peak            Project : 600550            Mode : 3            Setting : 08</p>

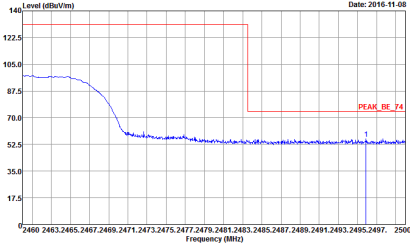
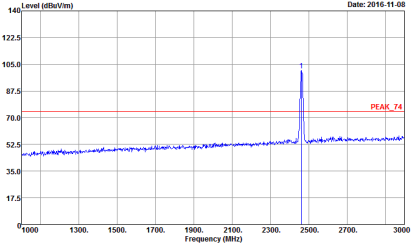
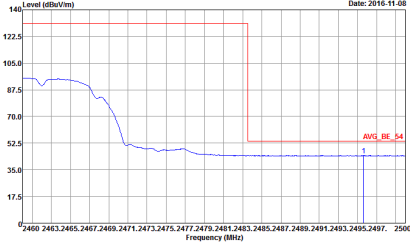
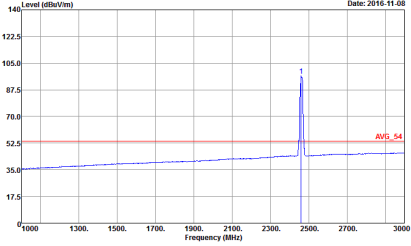

WIFI	2.4GHz 2400~2483.5MHz Band Edge @ 3m	
ANT	802.11b CH11 2462MHz	
1	<p style="text-align: center;"><b>Vertical</b></p>  <p style="text-align: center;"><b>Peak</b></p> <pre> Site      : 03CH12-HY Condition : PEAK_BE_74 3m HORN_9120D_1328 VERTICAL Detector  : RBW:1000.000kHz VBW:3000.000kHz SWT:Auto Project   : Peak Mode      : 600550 Setting   : 3            : 08           </pre>	<p style="text-align: center;"><b>Fundamental</b></p>  <pre> Site      : 03CH12-HY Condition : PEAK_74 3m HORN_9120D_1328 VERTICAL Detector  : RBW:1000.000kHz VBW:3000.000kHz SWT:Auto Project   : Peak Mode      : 600550 Setting   : 3            : 08           </pre>
Avg.	 <pre> Site      : 03CH12-HY Condition : AVG_BE_54 3m HORN_9120D_1328 VERTICAL Detector  : RBW:1000.000kHz VBW:0.300kHz SWT:Auto Project   : Peak Mode      : 600550 Setting   : 3            : 08           </pre>	 <pre> Site      : 03CH12-HY Condition : AVG_54 3m HORN_9120D_1328 VERTICAL Detector  : RBW:1000.000kHz VBW:0.300kHz SWT:Auto Project   : Peak Mode      : 600550 Setting   : 3            : 08           </pre>

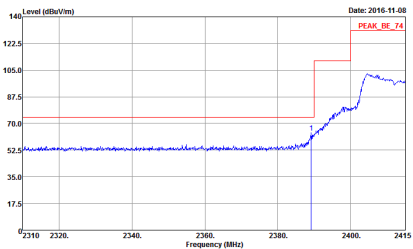
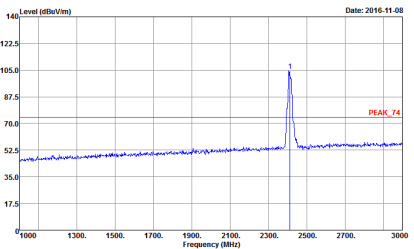
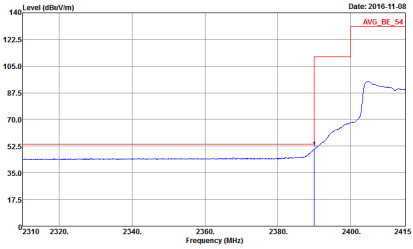
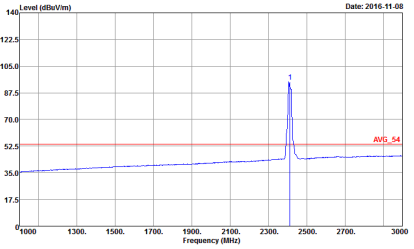

2.4GHz 2400~2483.5MHz  
WIFI 802.11g (Band Edge @ 3m)

WIFI	2.4GHz 2400~2483.5MHz Band Edge @ 3m	
ANT	802.11g CH01 2412MHz	
1	Horizontal	Fundamental
Peak	 <p>Site : 03CH12-HY Condition : PEAK_BE_74 3m HORN_9120D_1328 HORIZONTAL Detector : RBW:1000.000KHz VBW:3000.000KHz SWT:Auto Project : Peak Mode : 600550 Setting : 4  : 10</p>	 <p>Site : 03CH12-HY Condition : PEAK_74 3m HORN_9120D_1328 HORIZONTAL Detector : RBW:1000.000KHz VBW:3000.000KHz SWT:Auto Project : Peak Mode : 600550 Setting : 4  : 10</p>
Avg.	 <p>Site : 03CH12-HY Condition : AVG_BE_54 3m HORN_9120D_1328 HORIZONTAL Detector : RBW:1000.000KHz VBW:1.000KHz SWT:Auto Project : Peak Mode : 600550 Setting : 4  : 10</p>	 <p>Site : 03CH12-HY Condition : AVG_54 3m HORN_9120D_1328 HORIZONTAL Detector : RBW:1000.000KHz VBW:1.000KHz SWT:Auto Project : Peak Mode : 600550 Setting : 4  : 10</p>

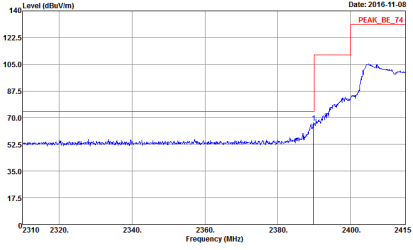
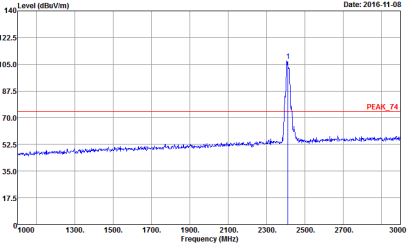
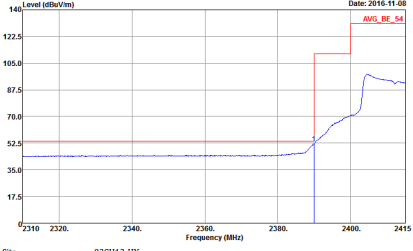
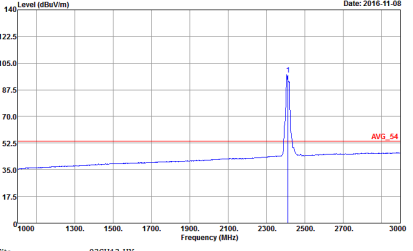

WIFI	2.4GHz 2400~2483.5MHz Band Edge @ 3m	
ANT	802.11g CH01 2412MHz	
1	Vertical	Fundamental
Peak	 <p>Site Condition : 03CH12-HY : PEAK_BE_74 3m HORN_9120D_1328 VERTICAL : RBW:1000.000KHz VBW:3000.000KHz SWT:Auto Detector : Peak Project : 600550 Mode : 4 Setting : 10</p>	 <p>Site Condition : 03CH12-HY : PEAK_74 3m HORN_9120D_1328 VERTICAL : RBW:1000.000KHz VBW:3000.000KHz SWT:Auto Detector : Peak Project : 600550 Mode : 4 Setting : 10</p>
Avg.	 <p>Site Condition : 03CH12-HY : AVG_BE_54 3m HORN_9120D_1328 VERTICAL : RBW:1000.000KHz VBW:1.000KHz SWT:Auto Detector : Peak Project : 600550 Mode : 4 Setting : 10</p>	 <p>Site Condition : 03CH12-HY : AVG_54 3m HORN_9120D_1328 VERTICAL : RBW:1000.000KHz VBW:1.000KHz SWT:Auto Detector : Peak Project : 600550 Mode : 4 Setting : 10</p>

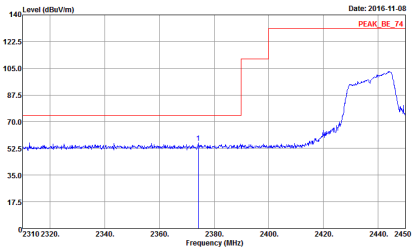
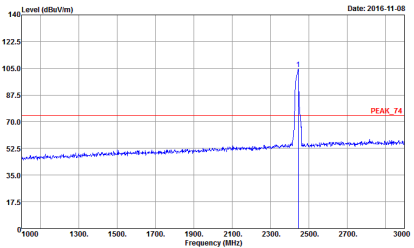
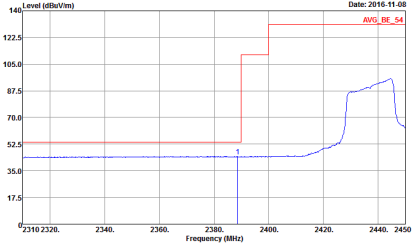
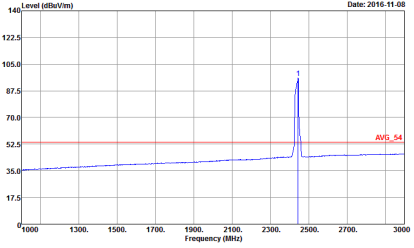

WIFI	2.4GHz 2400~2483.5MHz Band Edge @ 3m	
ANT	802.11g CH06 2437MHz - L	
1	<p style="text-align: center;"><b>Horizontal</b></p>  <p>Site Condition : 03CH12-HY            : PEAK_BE_74 3m HORN_9120D_1328 HORIZONTAL            : RBW:1000.000KHz VBW:3000.000KHz SWT:Auto            Detector : Peak            Project : 600550            Mode : S            Setting : 0A</p>	<p style="text-align: center;"><b>Fundamental</b></p>  <p>Site Condition : 03CH12-HY            : PEAK_74 3m HORN_9120D_1328 HORIZONTAL            : RBW:1000.000KHz VBW:3000.000KHz SWT:Auto            Detector : Peak            Project : 600550            Mode : S            Setting : 0A</p>
Avg.	 <p>Site Condition : 03CH12-HY            : AVG_BE_54 3m HORN_9120D_1328 HORIZONTAL            : RBW:1000.000KHz VBW:1.000KHz SWT:Auto            Detector : Peak            Project : 600550            Mode : S            Setting : 0A</p>	 <p>Site Condition : 03CH12-HY            : AVG_54 3m HORN_9120D_1328 HORIZONTAL            : RBW:1000.000KHz VBW:1.000KHz SWT:Auto            Detector : Peak            Project : 600550            Mode : S            Setting : 0A</p>

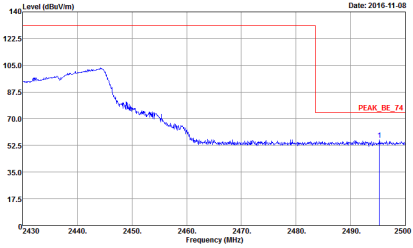
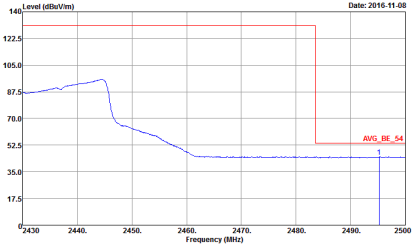

WIFI	2.4GHz 2400~2483.5MHz Band Edge @ 3m	
ANT	802.11g CH06 2437MHz - R	
1	Horizontal	Fundamental
Peak	 <p>           Date: 2016-11-08            Site : 03CH12-HY            Condition : PEAK_BE_74 3m HORN_9120D_1328 HORIZONTAL            : RBW:1000.000KHz VBW:3000.000KHz SWT:Auto            Detector : Peak            Project : 600550            Mode : S            Setting : 0A         </p>	Left blank
Avg.	 <p>           Date: 2016-11-08            Site : 03CH12-HY            Condition : AVG_BE_54 3m HORN_9120D_1328 HORIZONTAL            : RBW:1000.000KHz VBW:1.000KHz SWT:Auto            Detector : Peak            Project : 600550            Mode : S            Setting : 0A         </p>	Left blank

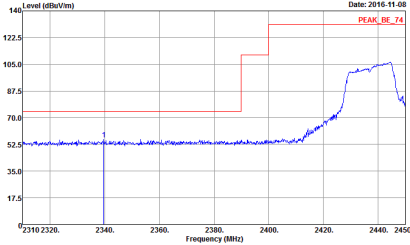
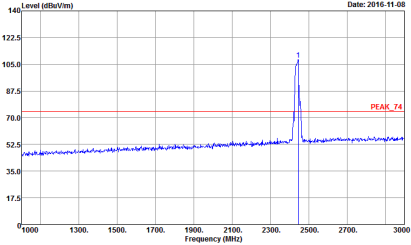
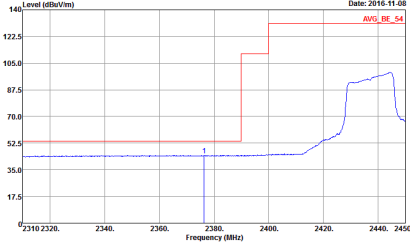
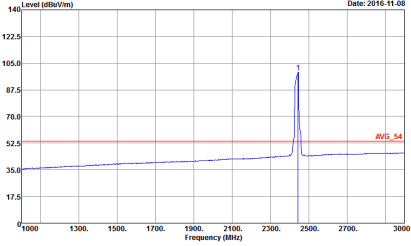

WIFI	2.4GHz 2400~2483.5MHz Band Edge @ 3m	
ANT	802.11g CH06 2437MHz - L	
1	<p style="text-align: center;"><b>Vertical</b></p>  <p>Site Condition : 03CH12-HY : PEAK_BE_74 3m HORN_9120D_1328 VERTICAL : RBW:1000.000KHz VBW:3000.000KHz SWT:Auto Detector : Peak Project : 600550 Mode : S Setting : 0A</p>	<p style="text-align: center;"><b>Fundamental</b></p>  <p>Site Condition : 03CH12-HY : PEAK_74 3m HORN_9120D_1328 VERTICAL : RBW:1000.000KHz VBW:3000.000KHz SWT:Auto Detector : Peak Project : 600550 Mode : S Setting : 0A</p>
Peak	 <p>Site Condition : 03CH12-HY : AVG_BE_54 3m HORN_9120D_1328 VERTICAL : RBW:1000.000KHz VBW:1.000KHz SWT:Auto Detector : Peak Project : 600550 Mode : S Setting : 0A</p>	 <p>Site Condition : 03CH12-HY : AVG_54 3m HORN_9120D_1328 VERTICAL : RBW:1000.000KHz VBW:1.000KHz SWT:Auto Detector : Peak Project : 600550 Mode : S Setting : 0A</p>
Avg.		

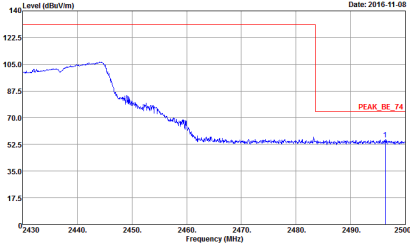
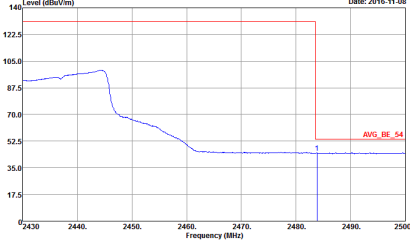

WIFI	2.4GHz 2400~2483.5MHz Band Edge @ 3m	
ANT	802.11g CH06 2437MHz - R	
1	Vertical	Fundamental
Peak	 <p>           Site : 03CH12-HY            Condition : PEAK_BE_74 3m HORN_9120D_1328 VERTICAL            : RBW:1000.000KHz VBW:3000.000KHz SWT:Auto            Detector : Peak            Project : 600550            Mode : S            Setting : 0A         </p>	Left Blank
Avg.	 <p>           Site : 03CH12-HY            Condition : AVG_BE_54 3m HORN_9120D_1328 VERTICAL            : RBW:1000.000KHz VBW:1.000KHz SWT:Auto            Detector : Peak            Project : 600550            Mode : S            Setting : 0A         </p>	Left Blank



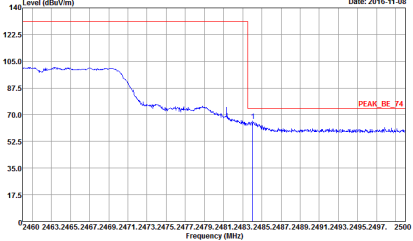
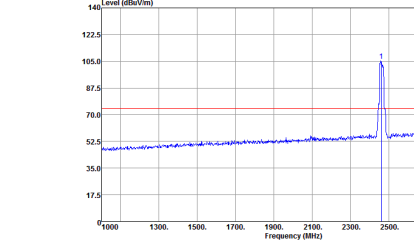
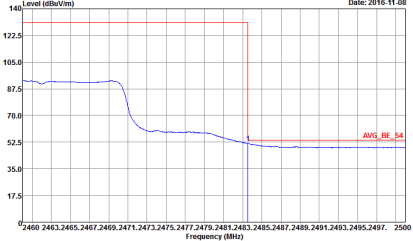
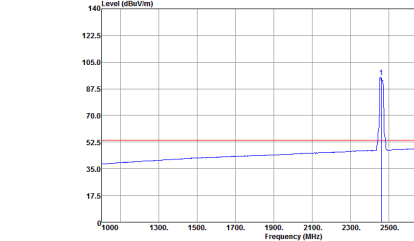

WIFI	2.4GHz 2400~2483.5MHz Band Edge @ 3m	
ANT	802.11g CH11 2462MHz	
1	Horizontal	Fundamental
Peak	 <p>Date: 2016-11-08</p> <p>Site Condition : 03CH12-HY : PEAK_BE_74 3m HORN_9120D_1328 HORIZONTAL : RBW:1000.000kHz VBW:3000.000kHz SWT:Auto Detector : Peak Project : 600550 Mode : 6 Setting : 0C</p>	 <p>Date: 2016-11-08</p> <p>Site Condition : 03CH12-HY : PEAK_74 3m HORN_9120D_1328 HORIZONTAL : RBW:1000.000kHz VBW:3000.000kHz SWT:Auto Detector : Peak Project : 600550 Mode : 6 Setting : 0C</p>
Avg.	 <p>Date: 2016-11-08</p> <p>Site Condition : 03CH12-HY : AVG_BE_54 3m HORN_9120D_1328 HORIZONTAL : RBW:1000.000kHz VBW:1.000kHz SWT:Auto Detector : Peak Project : 600550 Mode : 6 Setting : 0C</p>	 <p>Date: 2016-11-08</p> <p>Site Condition : 03CH12-HY : AVG_54 3m HORN_9120D_1328 HORIZONTAL : RBW:1000.000kHz VBW:1.000kHz SWT:Auto Detector : Peak Project : 600550 Mode : 6 Setting : 0C</p>

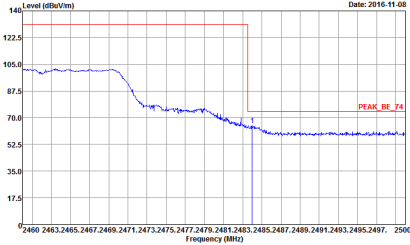
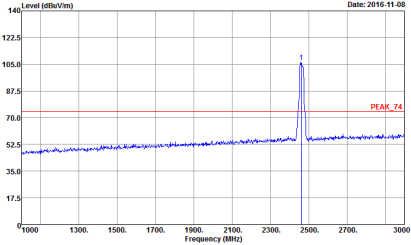
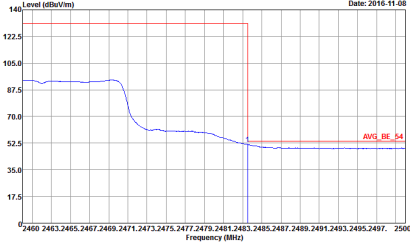
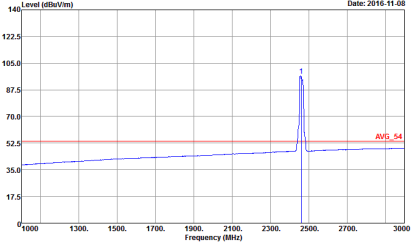

WIFI	2.4GHz 2400~2483.5MHz Band Edge @ 3m	
ANT	802.11g CH11 2462MHz	
1	<p style="text-align: center;"><b>Vertical</b></p>  <p>Level (dBuV/m) vs Frequency (MHz) plot showing a peak at 2462 MHz. The y-axis ranges from 17.5 to 140 dBuV/m, and the x-axis ranges from 2460 to 2500 MHz. A red box highlights the peak area, and a red line indicates the peak level at approximately 125 dBuV/m.</p> <p><b>Peak</b></p> <pre> Site      : 03CH12-HY Condition : PEAK_BE_74 3m HORN_9120D_1328 VERTICAL Detector  : RBW:1000.000KHz VBW:3000.000KHz SWT:Auto Project   : Peak Mode      : 600550 Setting   : 0C           </pre>	<p style="text-align: center;"><b>Fundamental</b></p>  <p>Level (dBuV/m) vs Frequency (MHz) plot showing a sharp peak at 2462 MHz. The y-axis ranges from 17.5 to 140 dBuV/m, and the x-axis ranges from 1000 to 3000 MHz. A red box highlights the peak area, and a red line indicates the peak level at approximately 125 dBuV/m.</p> <p><b>Peak</b></p> <pre> Site      : 03CH12-HY Condition : PEAK_74 3m HORN_9120D_1328 VERTICAL Detector  : RBW:1000.000KHz VBW:3000.000KHz SWT:Auto Project   : Peak Mode      : 600550 Setting   : 0C           </pre>
Avg.	 <p>Level (dBuV/m) vs Frequency (MHz) plot showing the average level across the band. The y-axis ranges from 17.5 to 140 dBuV/m, and the x-axis ranges from 2460 to 2500 MHz. A red box highlights the average level at approximately 55 dBuV/m.</p> <p><b>Avg.</b></p> <pre> Site      : 03CH12-HY Condition : AVG_BE_54 3m HORN_9120D_1328 VERTICAL Detector  : RBW:1000.000KHz VBW:1.000KHz SWT:Auto Project   : Peak Mode      : 600550 Setting   : 6           </pre>	 <p>Level (dBuV/m) vs Frequency (MHz) plot showing the average level across the band. The y-axis ranges from 17.5 to 140 dBuV/m, and the x-axis ranges from 1000 to 3000 MHz. A red box highlights the average level at approximately 55 dBuV/m.</p> <p><b>Avg.</b></p> <pre> Site      : 03CH12-HY Condition : AVG_54 3m HORN_9120D_1328 VERTICAL Detector  : RBW:1000.000KHz VBW:1.000KHz SWT:Auto Project   : Peak Mode      : 600550 Setting   : 0C           </pre>



2.4GHz 2400~2483.5MHz
WIFI 802.11b (Harmonic @ 3m)

Table with 2 columns: WIFI (2.4GHz 2400~2483.5MHz Harmonic @ 3m), ANT (802.11b CH01 2412MHz). Row 1: 1. Sub-headers: Horizontal, Vertical. Content: Two spectral plots showing Level (dBuV/m) vs Frequency (MHz) for Horizontal and Vertical orientations. Includes metadata like Site, Condition, Detector, Project, Mode, Setting.

Peak
Avg.

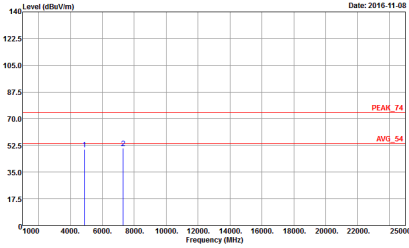
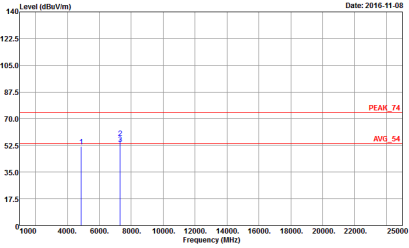

WIFI	2.4GHz 2400~2483.5MHz Harmonic @ 3m	
ANT	802.11b CH06 2437MHz	
1	Horizontal	Vertical
Peak Avg.	 <p>Site : 03CH12-HY Condition : PEAK_74 3m HORN_9120D_1328 HORIZONTAL Detector : Peak Project : 600550 Mode : 2 Setting : 09</p>	 <p>Site : 03CH12-HY Condition : PEAK_74 3m HORN_9120D_1328 VERTICAL Detector : Peak Project : 600550 Mode : 2 Setting : 09</p>

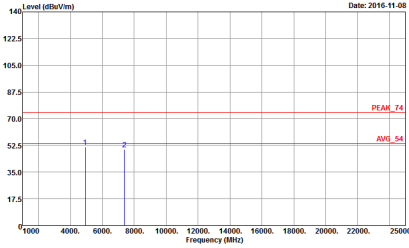
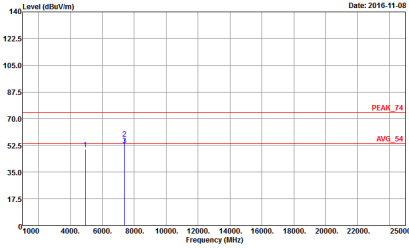

WIFI	2.4GHz 2400~2483.5MHz Harmonic @ 3m	
ANT	802.11b CH11 2462MHz	
1	Horizontal	Vertical
<p><b>Peak</b></p> <p><b>Avg.</b></p>	 <p>Site : 03CH12-HY            Condition : PEAK_74 3m HORN_9120D_1328 HORIZONTAL            Detector : Peak            Project : 600550            Mode : 3            Setting : 00</p>	 <p>Site : 03CH12-HY            Condition : PEAK_74 3m HORN_9120D_1328 VERTICAL            Detector : Peak            Project : 600550            Mode : 3            Setting : 00</p>



2.4GHz 2400~2483.5MHz  
WIFI 802.11g (Harmonic @ 3m)

WIFI	2.4GHz 2400~2483.5MHz Harmonic @ 3m	
ANT	802.11g CH01 2412MHz	
1	Horizontal	Vertical
<b>Peak</b>  <b>Avg.</b>	<p>Site : 03CH12-HY            Condition : PEAK_74 3m HORN_9120D_1328 HORIZONTAL            Detector : Peak            Project : 600550            Mode : 4            Setting : 10</p>	<p>Site : 03CH12-HY            Condition : PEAK_74 3m HORN_9120D_1328 VERTICAL            Detector : Peak            Project : 600550            Mode : 4            Setting : 10</p>

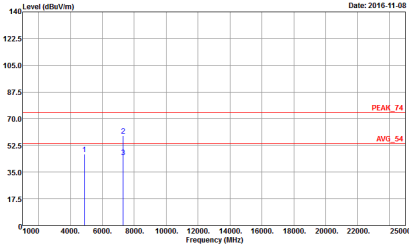
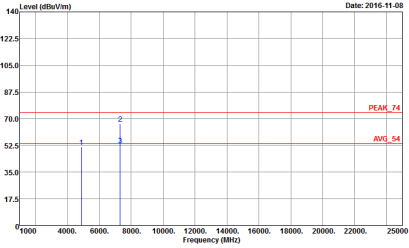

WIFI	2.4GHz 2400~2483.5MHz Harmonic @ 3m	
ANT	802.11g CH06 2437MHz	
1	Horizontal	Vertical
Peak Avg.	 <p>Site : 03CH12-HY Condition : PEAK_74 3m HORN_9120D_1328 HORIZONTAL Detector : Peak Project : 600550 Mode : S Setting : 0A</p>	 <p>Site : 03CH12-HY Condition : PEAK_74 3m HORN_9120D_1328 VERTICAL Detector : Peak Project : 600550 Mode : S Setting : 0A</p>

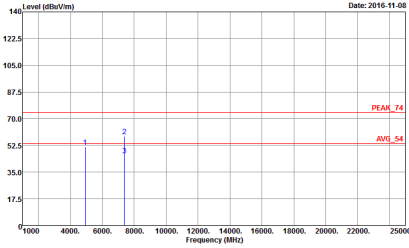
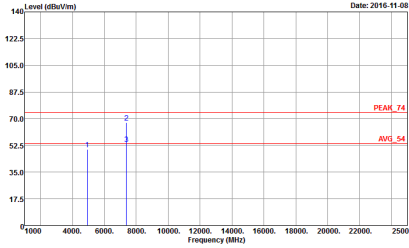

WIFI	2.4GHz 2400~2483.5MHz Harmonic @ 3m	
ANT	802.11g CH11 2462MHz	
1	Horizontal	Vertical
<p><b>Peak</b></p> <p><b>Avg.</b></p>	 <p>Site : 03CH12-HY          Condition : PEAK_74 3m HORN_9120D_1328 HORIZONTAL          Detector : Peak          Project : 600550          Mode : 6          Setting : 0C</p>	 <p>Site : 03CH12-HY          Condition : PEAK_74 3m HORN_9120D_1328 VERTICAL          Detector : Peak          Project : 600550          Mode : 6          Setting : 0C</p>



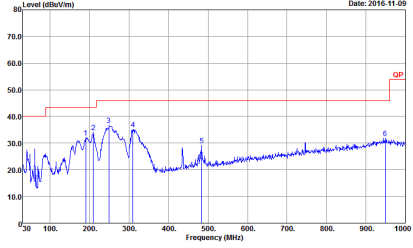
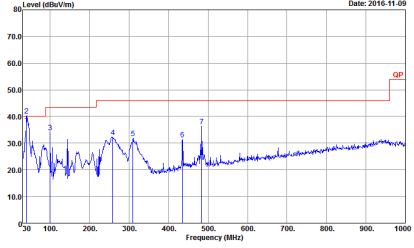

Emission below 1GHz  
2.4GHz WIFI 802.11g (LF)

WIFI	2.4GHz 2400~2483.5MHz	
ANT	802.11g LF	
1	Horizontal	Vertical
QP / Peak	 <p>Site : 03CH12-HY Condition : QP 3m BILLOG_6111D_37059 HORIZONTAL Detector : Peak Project : 600550 Mode : 14</p>	 <p>Site : 03CH12-HY Condition : QP 3m BILLOG_6111D_37059 VERTICAL Detector : Peak Project : 600550 Mode : 14</p>

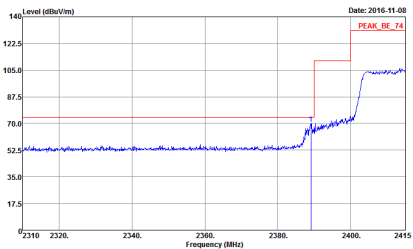
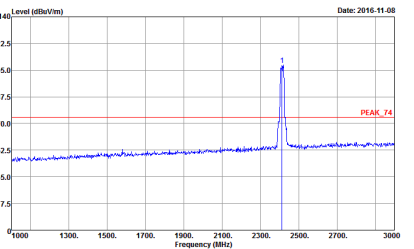
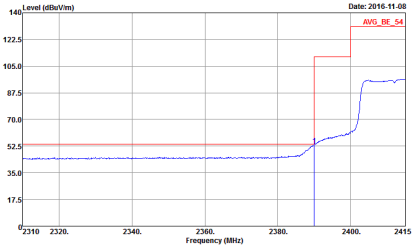
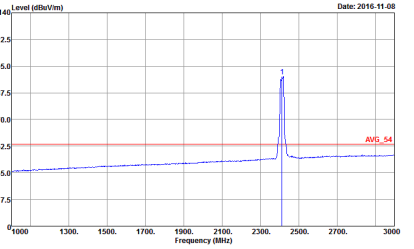

2.4GHz 2400~2483.5MHz  
 WIFI 802.11n HT20 (Band Edge @ 3m)

WIFI	2.4GHz 2400~2483.5MHz Band Edge @ 3m	
ANT	802.11n HT20 CH01 2412MHz	
1+2	Horizontal	Fundamental
Peak	 <p>Site : 03CH12-HY            Condition : PEAK_BE_74 3m HORN_9120D_1328 HORIZONTAL            Detector : RBW:1000.000KHz VBW:3000.000KHz SWT:Auto            Project : Peak            Mode : 600550            Setting : 7            : 0C</p>	 <p>Site : 03CH12-HY            Condition : PEAK_74 3m HORN_9120D_1328 HORIZONTAL            Detector : RBW:1000.000KHz VBW:3000.000KHz SWT:Auto            Project : Peak            Mode : 600550            Setting : 7            : 0C</p>
Avg.	 <p>Site : 03CH12-HY            Condition : AVG_BE_54 3m HORN_9120D_1328 HORIZONTAL            Detector : RBW:1000.000KHz VBW:3.000KHz SWT:Auto            Project : Peak            Mode : 600550            Setting : 7            : 0C</p>	 <p>Site : 03CH12-HY            Condition : AVG_54 3m HORN_9120D_1328 HORIZONTAL            Detector : RBW:1000.000KHz VBW:3.000KHz SWT:Auto            Project : Peak            Mode : 600550            Setting : 7            : 0C</p>

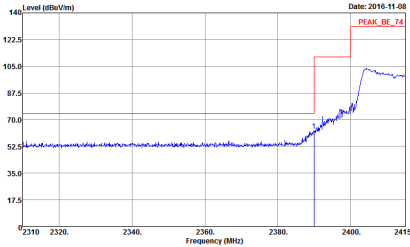
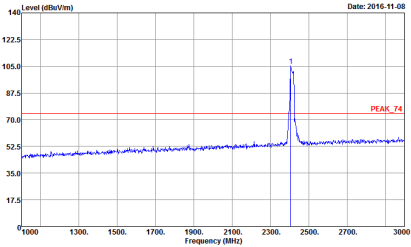
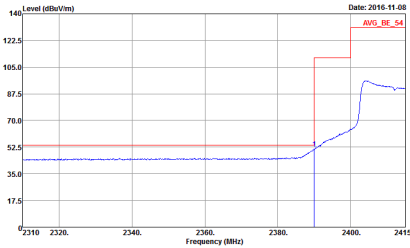
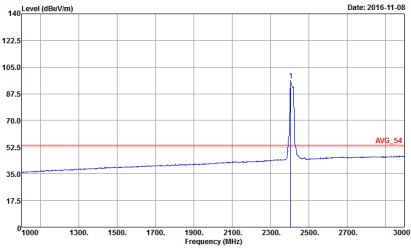

WIFI	2.4GHz 2400~2483.5MHz Band Edge @ 3m	
ANT	802.11n HT20 CH01 2412MHz	
1+2	Vertical	Fundamental
Peak	 <p>Date: 2016-11-08 PEAK_BE_74</p> <p>Site Condition : 03CH12-HY : PEAK_BE_74 3m HORN_9120D_1328 VERTICAL : RBW:1000.000KHz VBW:3000.000KHz SWT:Auto Detector : Peak Project : 600550 Mode : 7 Setting : 0C</p>	 <p>Date: 2016-11-08 PEAK_74</p> <p>Site Condition : 03CH12-HY : PEAK_74 3m HORN_9120D_1328 VERTICAL : RBW:1000.000KHz VBW:3000.000KHz SWT:Auto Detector : Peak Project : 600550 Mode : 7 Setting : 0C</p>
Avg.	 <p>Date: 2016-11-08 AVG_BE_54</p> <p>Site Condition : 03CH12-HY : AVG_BE_54 3m HORN_9120D_1328 VERTICAL : RBW:1000.000KHz VBW:3.000KHz SWT:Auto Detector : Peak Project : 600550 Mode : 7 Setting : 0C</p>	 <p>Date: 2016-11-08 AVG_54</p> <p>Site Condition : 03CH12-HY : AVG_54 3m HORN_9120D_1328 VERTICAL : RBW:1000.000KHz VBW:3.000KHz SWT:Auto Detector : Peak Project : 600550 Mode : 7 Setting : 0C</p>

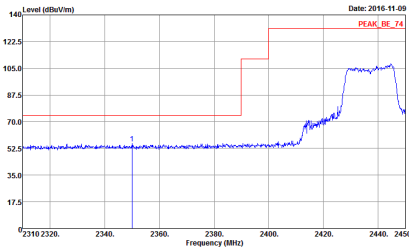
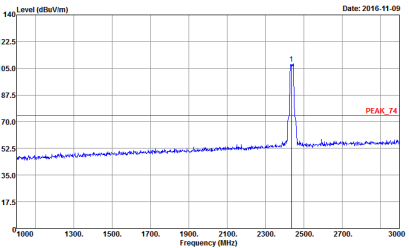
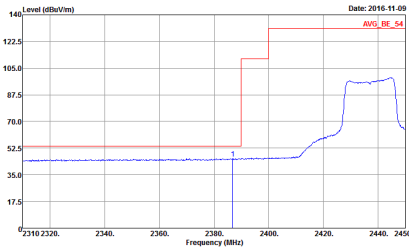
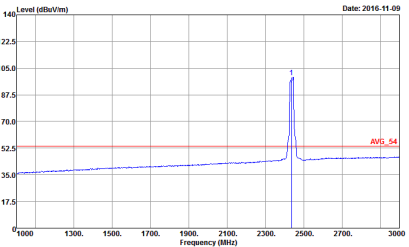

WIFI	2.4GHz 2400~2483.5MHz Band Edge @ 3m	
ANT	802.11n HT20 CH06 2437MHz - L	
1+2	Horizontal	Fundamental
Peak	 <p>Date: 2016-11-09 PEAK_BE_74</p> <p>Site Condition : 03CH12-HY : PEAK_BE_74 3m HORN_9120D_1328 HORIZONTAL : RBW:1000.000KHz VBW:3000.000KHz SWT:Auto Detector : Peak Project : 600550 Mode : B Setting : 0C</p>	 <p>Date: 2016-11-09 PEAK_74</p> <p>Site Condition : 03CH12-HY : PEAK_74 3m HORN_9120D_1328 HORIZONTAL : RBW:1000.000KHz VBW:3000.000KHz SWT:Auto Detector : Peak Project : 600550 Mode : B Setting : 0C</p>
Avg.	 <p>Date: 2016-11-09 AVG_BE_54</p> <p>Site Condition : 03CH12-HY : AVG_BE_54 3m HORN_9120D_1328 HORIZONTAL : RBW:1000.000KHz VBW:3.000KHz SWT:Auto Detector : Peak Project : 600550 Mode : B Setting : 0C</p>	 <p>Date: 2016-11-09 AVG_54</p> <p>Site Condition : 03CH12-HY : AVG_54 3m HORN_9120D_1328 HORIZONTAL : RBW:1000.000KHz VBW:3.000KHz SWT:Auto Detector : Peak Project : 600550 Mode : B Setting : 0C</p>

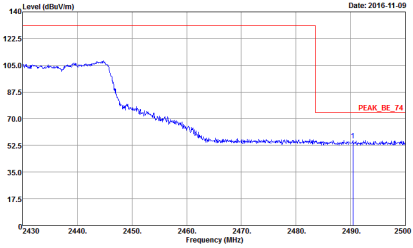
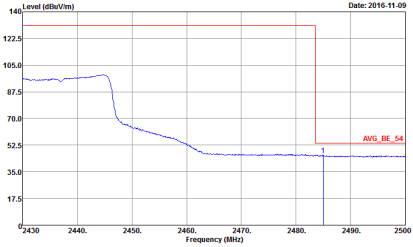

WIFI	2.4GHz 2400~2483.5MHz Band Edge @ 3m	
ANT	802.11n HT20 CH06 2437MHz - R	
1+2	Horizontal	Fundamental
Peak	 <p>Site : 03CH12-HY Condition : PEAK_BE_74 3m HORN_9120D_1328 HORIZONTAL RBW:1000.000KHz VBW:3000.000KHz SWT:Auto Detector : Peak Project : 600550 Mode : B Setting : OC</p>	Left blank
Avg.	 <p>Site : 03CH12-HY Condition : AVG_BE_54 3m HORN_9120D_1328 HORIZONTAL RBW:1000.000KHz VBW:3.000KHz SWT:Auto Detector : Peak Project : 600550 Mode : B Setting : OC</p>	Left blank

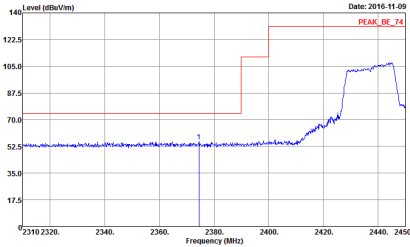
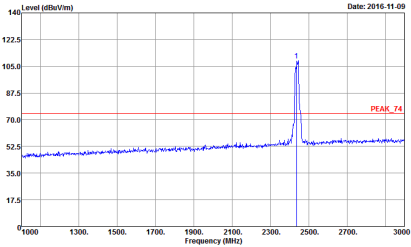
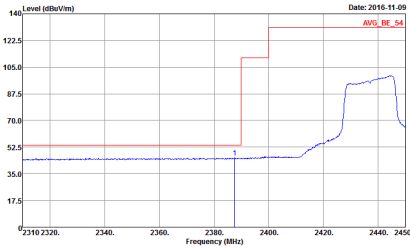
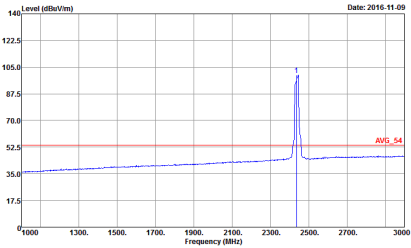

WIFI	2.4GHz 2400~2483.5MHz Band Edge @ 3m	
ANT	802.11n HT20 CH06 2437MHz - L	
1+2	Vertical	Fundamental
Peak	 <p>Date: 2016-11-09 PEAK_BE_74</p> <p>Site Condition : 03CH12-HY : PEAK_BE_74 3m HORN_9120D_1328 VERTICAL : RBW:1000.000KHz VBW:3000.000KHz SWT:Auto Detector : Peak Project : 600550 Mode : B Setting : 0C</p>	 <p>Date: 2016-11-09 PEAK_74</p> <p>Site Condition : 03CH12-HY : PEAK_74 3m HORN_9120D_1328 VERTICAL : RBW:1000.000KHz VBW:3000.000KHz SWT:Auto Detector : Peak Project : 600550 Mode : B Setting : 0C</p>
Avg.	 <p>Date: 2016-11-09 AVG_BE_54</p> <p>Site Condition : 03CH12-HY : AVG_BE_54 3m HORN_9120D_1328 VERTICAL : RBW:1000.000KHz VBW:3.000KHz SWT:Auto Detector : Peak Project : 600550 Mode : B Setting : 0C</p>	 <p>Date: 2016-11-09 AVG_54</p> <p>Site Condition : 03CH12-HY : AVG_54 3m HORN_9120D_1328 VERTICAL : RBW:1000.000KHz VBW:3.000KHz SWT:Auto Detector : Peak Project : 600550 Mode : B Setting : 0C</p>

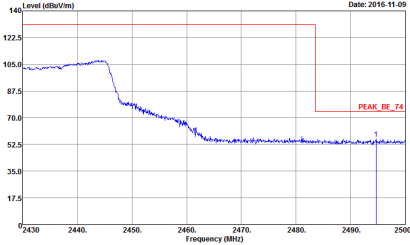
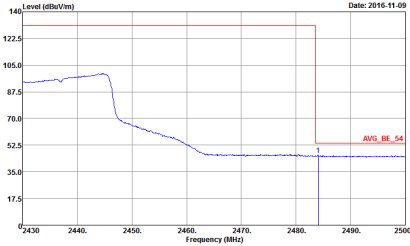

WIFI	2.4GHz 2400~2483.5MHz Band Edge @ 3m	
ANT	802.11n HT20 CH06 2437MHz - R	
1+2	Vertical	Fundamental
Peak	 <p>Date: 2016-11-09</p> <p>Site : 03CH12-HY  Condition : PEAK_BE_74 3m HORN_9120D_1328 VERTICAL  : RBW:1000.000KHz VBW:3000.000KHz SWT:Auto  Detector : Peak  Project : 600550  Mode : B  Setting : OC</p>	Left Blank
Avg.	 <p>Date: 2016-11-09</p> <p>Site : 03CH12-HY  Condition : AVG_BE_54 3m HORN_9120D_1328 VERTICAL  : RBW:1000.000KHz VBW:3.000KHz SWT:Auto  Detector : Peak  Project : 600550  Mode : B  Setting : OC</p>	Left Blank

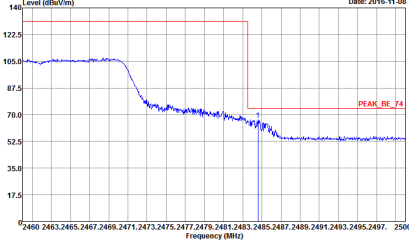
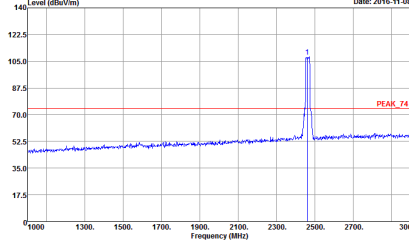
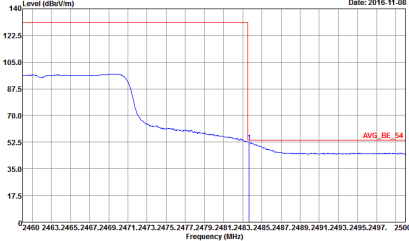
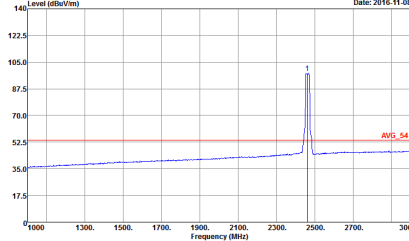

WIFI	2.4GHz 2400~2483.5MHz Band Edge @ 3m	
ANT	802.11n HT20 CH11 2462MHz	
1+2	Horizontal	Fundamental
Peak	 <p>Date: 2016-11-08</p> <p>Level (dBuV/m) vs Frequency (MHz)</p> <p>Peak: PEAK_BE_74</p> <pre> Site      : 03CH12-HY Condition : PEAK_BE_74 3m HORN_9120D_1328 HORIZONTAL Detector  : RBW:1000.000KHz VBW:3000.000KHz SWT:Auto Project   : Peak Mode      : 600550 Setting   : 9           : 0D           </pre>	 <p>Date: 2016-11-08</p> <p>Level (dBuV/m) vs Frequency (MHz)</p> <p>Peak: PEAK_74</p> <pre> Site      : 03CH12-HY Condition : PEAK_74 3m HORN_9120D_1328 HORIZONTAL Detector  : RBW:1000.000KHz VBW:3000.000KHz SWT:Auto Project   : Peak Mode      : 600550 Setting   : 9           : 0D           </pre>
Avg.	 <p>Date: 2016-11-08</p> <p>Level (dBuV/m) vs Frequency (MHz)</p> <p>Avg: AVG_BE_54</p> <pre> Site      : 03CH12-HY Condition : AVG_BE_54 3m HORN_9120D_1328 HORIZONTAL Detector  : RBW:1000.000KHz VBW:3.000KHz SWT:Auto Project   : Peak Mode      : 600550 Setting   : 9           : 0D           </pre>	 <p>Date: 2016-11-08</p> <p>Level (dBuV/m) vs Frequency (MHz)</p> <p>Avg: AVG_54</p> <pre> Site      : 03CH12-HY Condition : AVG_54 3m HORN_9120D_1328 HORIZONTAL Detector  : RBW:1000.000KHz VBW:3.000KHz SWT:Auto Project   : Peak Mode      : 600550 Setting   : 9           : 0D           </pre>



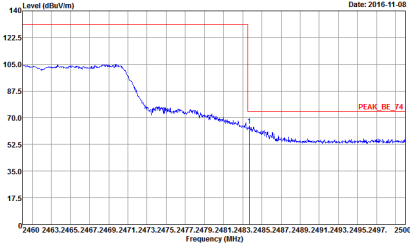
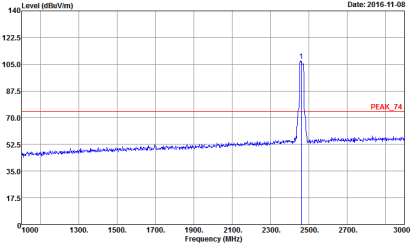
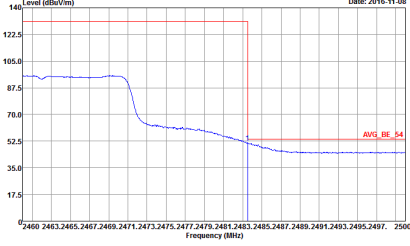
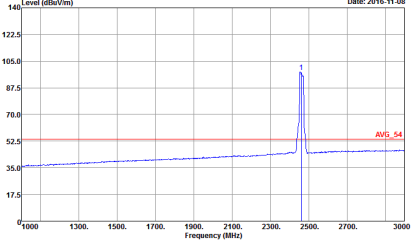

WIFI	2.4GHz 2400~2483.5MHz Fundamental @ 3m	
ANT	802.11n HT20 CH11 2462MHz	
1+2	Vertical	Fundamental
Peak	 <p>Site : 03CH12-HY            Condition : PEAK_BE_74 3m HORN_9120D_1328 VERTICAL            Detector : Peak            Project : 600550            Mode : 9            Setting : 0D</p>	 <p>Site : 03CH12-HY            Condition : PEAK_74 3m HORN_9120D_1328 VERTICAL            Detector : Peak            Project : 600550            Mode : 9            Setting : 0D</p>
Avg.	 <p>Site : 03CH12-HY            Condition : AVG_BE_54 3m HORN_9120D_1328 VERTICAL            Detector : Peak            Project : 600550            Mode : 9            Setting : 0D</p>	 <p>Site : 03CH12-HY            Condition : AVG_54 3m HORN_9120D_1328 VERTICAL            Detector : Peak            Project : 600550            Mode : 9            Setting : 0D</p>

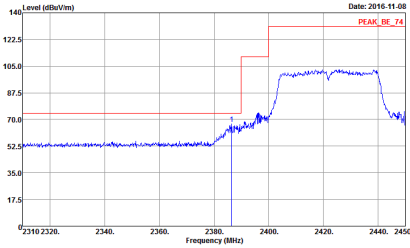
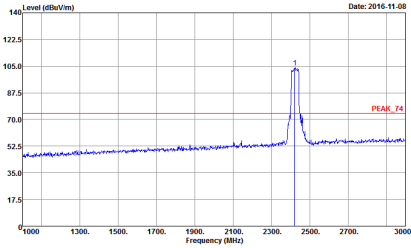
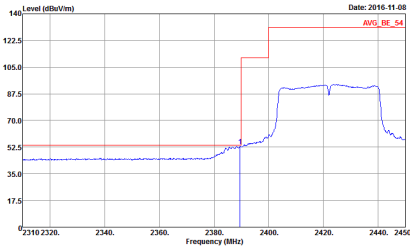
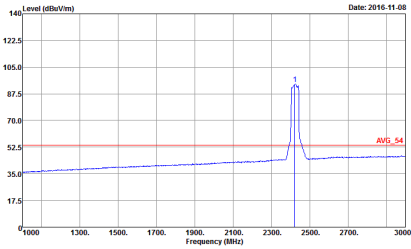

**2.4GHz 2400~2483.5MHz**  
**WIFI 802.11n HT40 (Band Edge @ 3m)**

WIFI	2.4GHz 2400~2483.5MHz Band Edge @ 3m	
ANT	802.11n HT40 CH03 2422MHz - L	
1+2	Horizontal	Fundamental
Peak	 <p>Date: 2016-11-08 PEAK_BE_74</p> <p>Site : 03CH12-HY Condition : PEAK_BE_74 3m HORN_9120D_1328 HORIZONTAL RBW:1000.000kHz VBW:3000.000kHz SWT:Auto Detector : Peak Project : 600550 Mode : 10 Setting : 09</p>	 <p>Date: 2016-11-08 PEAK_74</p> <p>Site : 03CH12-HY Condition : PEAK_74 3m HORN_9120D_1328 HORIZONTAL RBW:1000.000kHz VBW:3000.000kHz SWT:Auto Detector : Peak Project : 600550 Mode : 10 Setting : 09</p>
Avg.	 <p>Date: 2016-11-08 AVG_BE_54</p> <p>Site : 03CH12-HY Condition : AVG_BE_54 3m HORN_9120D_1328 HORIZONTAL RBW:1000.000kHz VBW:3.000kHz SWT:Auto Detector : Peak Project : 600550 Mode : 10 Setting : 09</p>	 <p>Date: 2016-11-08 AVG_54</p> <p>Site : 03CH12-HY Condition : AVG_54 3m HORN_9120D_1328 HORIZONTAL RBW:1000.000kHz VBW:3.000kHz SWT:Auto Detector : Peak Project : 600550 Mode : 10 Setting : 09</p>

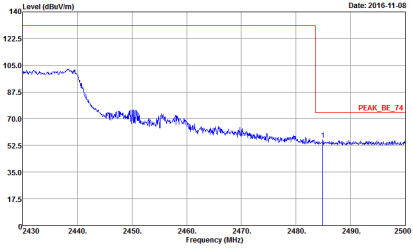
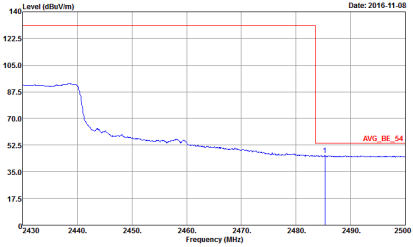

WIFI	2.4GHz 2400~2483.5MHz Band Edge @ 3m	
ANT	802.11n HT40 CH03 2422MHz - R	
1+2	Horizontal	Fundamental
Peak	 <p>Site : 03CH12-HY Condition : PEAK_BE_74 3m HORN_9120D_1328 HORIZONTAL RBW:1000.000KHz VBW:3000.000KHz SWT:Auto Detector : Peak Project : 600550 Mode : 10 Setting : 09</p>	Left Blank
Avg.	 <p>Site : 03CH12-HY Condition : AVG_BE_54 3m HORN_9120D_1328 HORIZONTAL RBW:1000.000KHz VBW:3.000KHz SWT:Auto Detector : Peak Project : 600550 Mode : 10 Setting : 09</p>	Left Blank

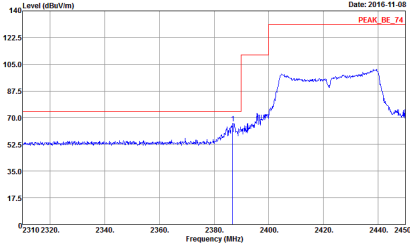
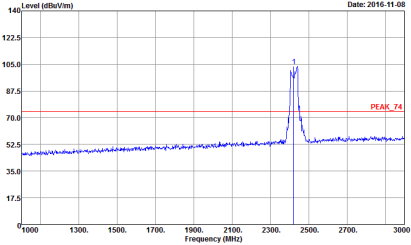
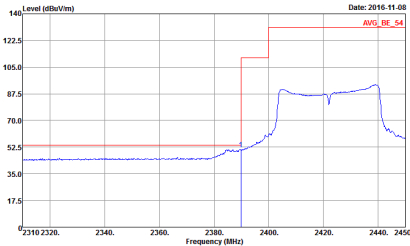
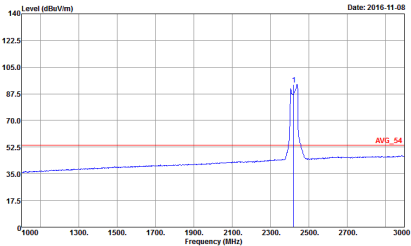

WIFI	2.4GHz 2400~2483.5MHz Band Edge @ 3m	
ANT	802.11n HT40 CH03 2422MHz - L	
1+2	Vertical	Fundamental
Peak	 <p>Date: 2016-11-08 PEAK_BE_74</p> <p>Site Condition : 03CH12-HY : PEAK_BE_74 3m HORN_9120D_1328 VERTICAL : RBW:1000.000KHz VBW:3000.000KHz SWT:Auto Detector : Peak Project : 600550 Mode : 10 Setting : 09</p>	 <p>Date: 2016-11-08 PEAK_74</p> <p>Site Condition : 03CH12-HY : PEAK_74 3m HORN_9120D_1328 VERTICAL : RBW:1000.000KHz VBW:3000.000KHz SWT:Auto Detector : Peak Project : 600550 Mode : 10 Setting : 09</p>
Avg.	 <p>Date: 2016-11-08 AVG_BE_54</p> <p>Site Condition : 03CH12-HY : AVG_BE_54 3m HORN_9120D_1328 VERTICAL : RBW:1000.000KHz VBW:3.000KHz SWT:Auto Detector : Peak Project : 600550 Mode : 10 Setting : 09</p>	 <p>Date: 2016-11-08 AVG_54</p> <p>Site Condition : 03CH12-HY : AVG_54 3m HORN_9120D_1328 VERTICAL : RBW:1000.000KHz VBW:3.000KHz SWT:Auto Detector : Peak Project : 600550 Mode : 10 Setting : 09</p>

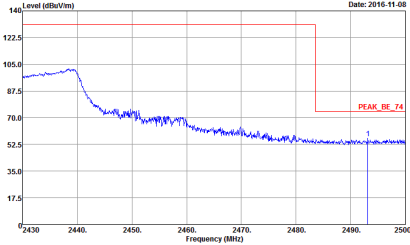
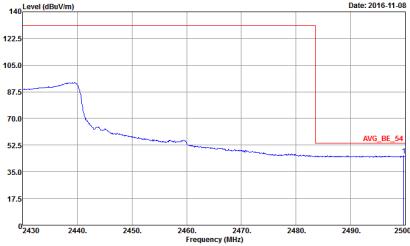

WIFI	2.4GHz 2400~2483.5MHz Band Edge @ 3m	
ANT	802.11n HT40 CH03 2422MHz - R	
1+2	Vertical	Fundamental
Peak	 <p>Date: 2016-11-08</p> <p>Site : 03CH12-HY  Condition : PEAK_BE_74 3m HORN_9120D_1328 VERTICAL  : RBW:1000.000KHz VBW:3000.000KHz SWT:Auto  Detector : Peak  Project : 600550  Mode : 10  Setting : 09</p>	Left blank
Avg.	 <p>Date: 2016-11-08</p> <p>Site : 03CH12-HY  Condition : AVG_BE_54 3m HORN_9120D_1328 VERTICAL  : RBW:1000.000KHz VBW:3.000KHz SWT:Auto  Detector : Peak  Project : 600550  Mode : 10  Setting : 09</p>	Left blank

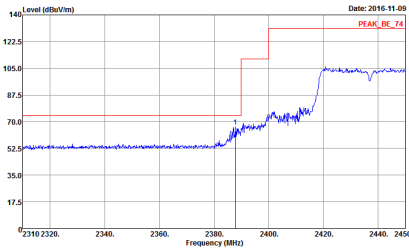
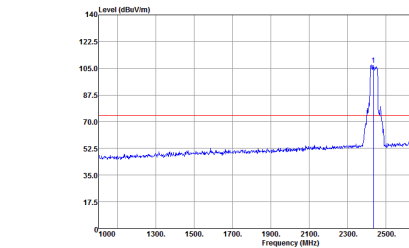
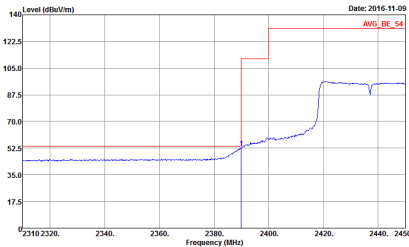
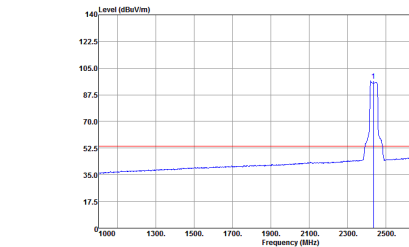

WIFI	2.4GHz 2400~2483.5MHz Band Edge @ 3m	
ANT	802.11n HT40 CH06 2437MHz - L	
1+2	Horizontal	Fundamental
Peak	 <p>Date: 2016-11-09 PEAK_BE_74</p> <p>Site Condition : 03CH12-HY : PEAK_BE_74 3m HORN_9120D_1328 HORIZONTAL : RBW:1000.000KHz VBW:3000.000KHz SWT:Auto Detector : Peak Project : 600550 Mode : 11 Setting : 0E</p>	 <p>Date: 2016-11-09 PEAK_74</p> <p>Site Condition : 03CH12-HY : PEAK_74 3m HORN_9120D_1328 HORIZONTAL : RBW:1000.000KHz VBW:3000.000KHz SWT:Auto Detector : Peak Project : 600550 Mode : 11 Setting : 0E</p>
Avg.	 <p>Date: 2016-11-09 AVG_BE_54</p> <p>Site Condition : 03CH12-HY : AVG_BE_54 3m HORN_9120D_1328 HORIZONTAL : RBW:1000.000KHz VBW:3.000KHz SWT:Auto Detector : Peak Project : 600550 Mode : 11 Setting : 0E</p>	 <p>Date: 2016-11-09 AVG_54</p> <p>Site Condition : 03CH12-HY : AVG_54 3m HORN_9120D_1328 HORIZONTAL : RBW:1000.000KHz VBW:3.000KHz SWT:Auto Detector : Peak Project : 600550 Mode : 11 Setting : 0E</p>

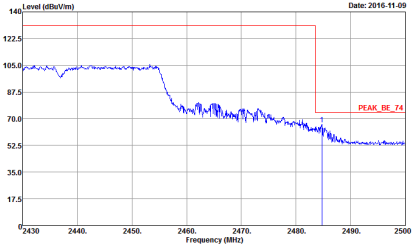
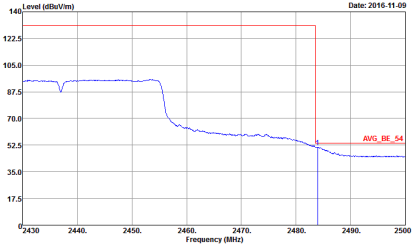

WIFI	2.4GHz 2400~2483.5MHz Band Edge @ 3m	
ANT	802.11n HT40 CH06 2437MHz - R	
1+2	Horizontal	Fundamental
<p><b>Peak</b></p>	 <p>Site : 03CH12-HY            Condition : PEAK_BE_74 3m HORN_9120D_1328 HORIZONTAL            : RBW:1000.000KHz VBW:3000.000KHz SWT:Auto            Detector : Peak            Project : 600550            Mode : 11            Setting : 0E</p>	<p>Left blank</p>
<p><b>Avg.</b></p>	 <p>Site : 03CH12-HY            Condition : AVG_BE_54 3m HORN_9120D_1328 HORIZONTAL            : RBW:1000.000KHz VBW:3.000KHz SWT:Auto            Detector : Peak            Project : 600550            Mode : 11            Setting : 0E</p>	<p>Left blank</p>

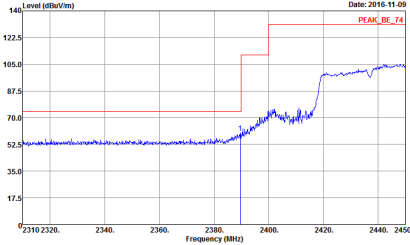
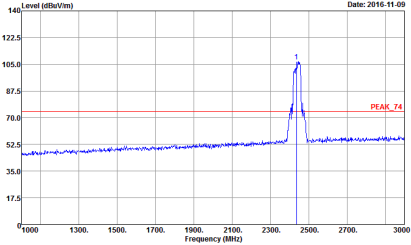
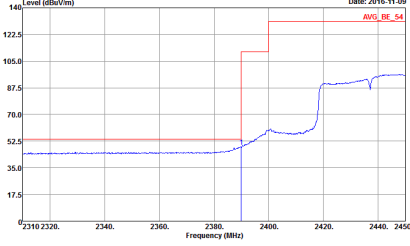
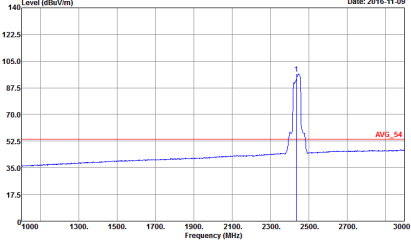

WIFI	2.4GHz 2400~2483.5MHz Band Edge @ 3m	
ANT	802.11n HT40 CH06 2437MHz - L	
1+2	Vertical	Fundamental
Peak	 <p>Date: 2016-11-09 PEAK_BE_74</p> <p>Site Condition : 03CH12-HY : PEAK_BE_74 3m HORN_9120D_1328 VERTICAL : RBW:1000.000KHz VBW:3000.000KHz SWT:Auto Detector : Peak Project : 600550 Mode : 11 Setting : 0E</p>	 <p>Date: 2016-11-09 PEAK_74</p> <p>Site Condition : 03CH12-HY : PEAK_74 3m HORN_9120D_1328 VERTICAL : RBW:1000.000KHz VBW:3000.000KHz SWT:Auto Detector : Peak Project : 600550 Mode : 11 Setting : 0E</p>
Avg.	 <p>Date: 2016-11-09 AVG_BE_54</p> <p>Site Condition : 03CH12-HY : AVG_BE_54 3m HORN_9120D_1328 VERTICAL : RBW:1000.000KHz VBW:3.000KHz SWT:Auto Detector : Peak Project : 600550 Mode : 11 Setting : 0E</p>	 <p>Date: 2016-11-09 AVG_54</p> <p>Site Condition : 03CH12-HY : AVG_54 3m HORN_9120D_1328 VERTICAL : RBW:1000.000KHz VBW:3.000KHz SWT:Auto Detector : Peak Project : 600550 Mode : 11 Setting : 0E</p>



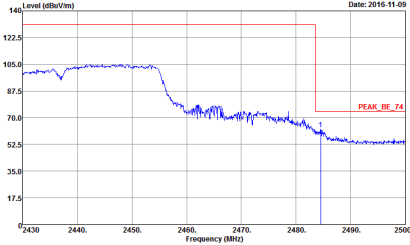
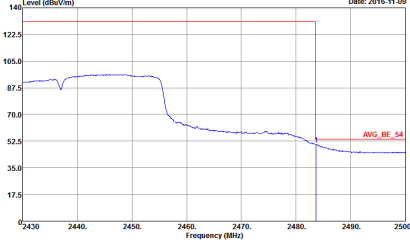

WIFI	2.4GHz 2400~2483.5MHz Band Edge @ 3m	
ANT	802.11n HT40 CH06 2437MHz - R	
1+2	Horizontal	Fundamental
Peak	 <p>Date: 2016-11-09</p> <p>Site : 03CH12-HY            Condition : PEAK_BE_74 3m HORN_9120D_1328 VERTICAL            : RBW:1000.000KHz VBW:3000.000KHz SWT:Auto            : Peak            Detector : 600550            Project : :11            Mode : :0E            Setting : :0E</p>	Left blank
Avg.	 <p>Date: 2016-11-09</p> <p>Site : 03CH12-HY            Condition : AVG_BE_54 3m HORN_9120D_1328 VERTICAL            : RBW:1000.000KHz VBW:3.000KHz SWT:Auto            : Peak            Detector : 600550            Project : :11            Mode : :0E            Setting : :0E</p>	Left blank

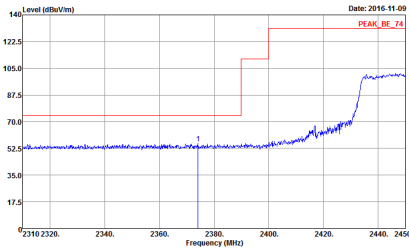
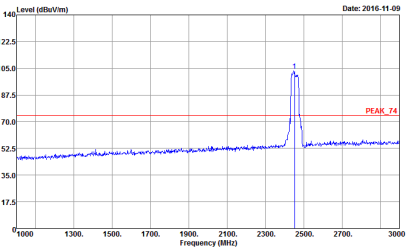
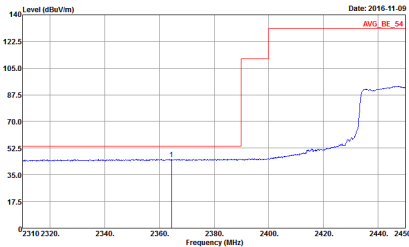
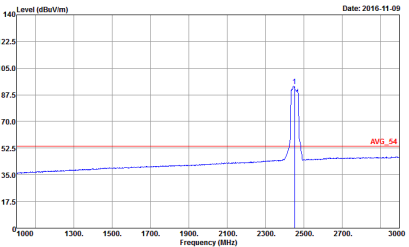

WIFI	2.4GHz 2400~2483.5MHz Band Edge @ 3m	
ANT	802.11n HT40 CH09 2452MHz - L	
1+2	Horizontal	Fundamental
Peak	 <p>Date: 2016-11-09 PEAK_BE_74</p> <p>Site Condition : 03CH12-HY : PEAK_BE_74 3m HORN_9120D_1328 HORIZONTAL : RBW:1000.000KHz VBW:3000.000KHz SWT:Auto Detector : Peak Project : 600550 Mode : 12 Setting : 06</p>	 <p>Date: 2016-11-09 PEAK_74</p> <p>Site Condition : 03CH12-HY : PEAK_74 3m HORN_9120D_1328 HORIZONTAL : RBW:1000.000KHz VBW:3000.000KHz SWT:Auto Detector : Peak Project : 600550 Mode : 12 Setting : 06</p>
Avg.	 <p>Date: 2016-11-09 AVG_BE_54</p> <p>Site Condition : 03CH12-HY : AVG_BE_54 3m HORN_9120D_1328 HORIZONTAL : RBW:1000.000KHz VBW:3.000KHz SWT:Auto Detector : Peak Project : 600550 Mode : 12 Setting : 06</p>	 <p>Date: 2016-11-09 AVG_54</p> <p>Site Condition : 03CH12-HY : AVG_54 3m HORN_9120D_1328 HORIZONTAL : RBW:1000.000KHz VBW:3.000KHz SWT:Auto Detector : Peak Project : 600550 Mode : 12 Setting : 06</p>

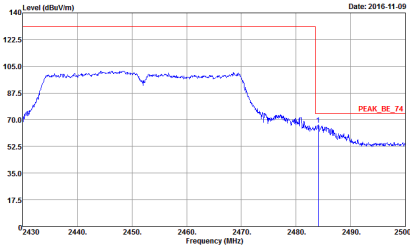
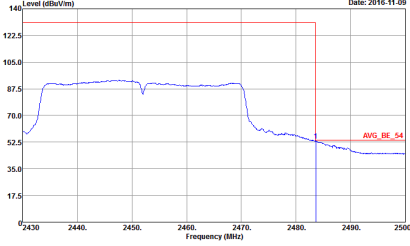

WIFI	2.4GHz 2400~2483.5MHz Band Edge @ 3m	
ANT	802.11n HT40 CH09 2452MHz - R	
1+2	Horizontal	Fundamental
Peak	 <p>Date: 2016-11-09</p> <p>Site : 03CH12-HY            Condition : PEAK_BE_74 3m HORN_9120D_1328 HORIZONTAL            Detector : RBW:1000.000KHz VBW:3000.000KHz SWT:Auto            Project : Peak            Mode : 600550            Setting : :12                      :06</p>	Left blank
Avg.	 <p>Date: 2016-11-09</p> <p>Site : 03CH12-HY            Condition : AVG_BE_54 3m HORN_9120D_1328 HORIZONTAL            Detector : RBW:1000.000KHz VBW:3.000KHz SWT:Auto            Project : Peak            Mode : 600550            Setting : :12                      :06</p>	Left blank

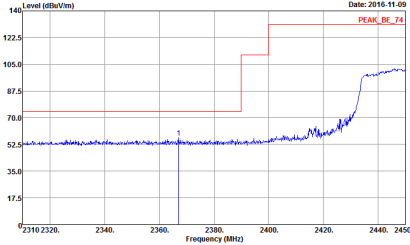
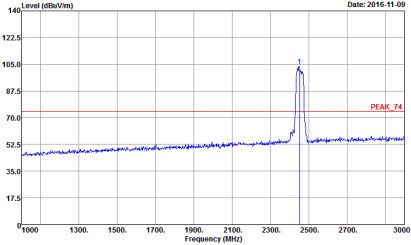
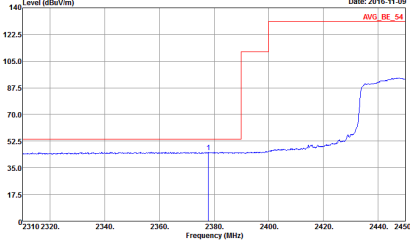
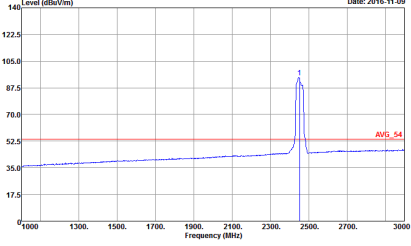

WIFI	2.4GHz 2400~2483.5MHz Band Edge @ 3m	
ANT	802.11n HT40 CH09 2452MHz - L	
1+2	Vertical	Fundamental
Peak	 <p>Date: 2016-11-09 PEAK_BE_74</p> <p>Site Condition : 03CH12-HY : PEAK_BE_74 3m HORN_9120D_1328 VERTICAL : RBW:1000.000KHz VBW:3000.000KHz SWT:Auto Detector : Peak Project : 600550 Mode : 12 Setting : 06</p>	 <p>Date: 2016-11-09 PEAK_74</p> <p>Site Condition : 03CH12-HY : PEAK_74 3m HORN_9120D_1328 VERTICAL : RBW:1000.000KHz VBW:3000.000KHz SWT:Auto Detector : Peak Project : 600550 Mode : 12 Setting : 06</p>
Avg.	 <p>Date: 2016-11-09 AVG_BE_54</p> <p>Site Condition : 03CH12-HY : AVG_BE_54 3m HORN_9120D_1328 VERTICAL : RBW:1000.000KHz VBW:3.000KHz SWT:Auto Detector : Peak Project : 600550 Mode : 12 Setting : 06</p>	 <p>Date: 2016-11-09 AVG_54</p> <p>Site Condition : 03CH12-HY : AVG_54 3m HORN_9120D_1328 VERTICAL : RBW:1000.000KHz VBW:3.000KHz SWT:Auto Detector : Peak Project : 600550 Mode : 12 Setting : 06</p>

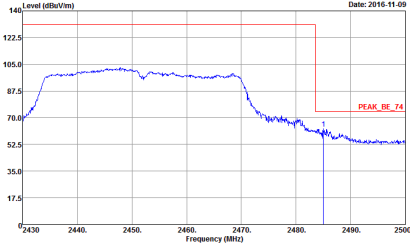
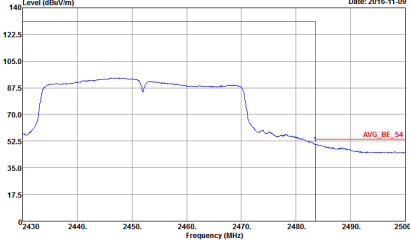

WIFI	2.4GHz 2400~2483.5MHz Band Edge @ 3m	
ANT	802.11n HT40 CH09 2452MHz - R	
1+2	Vertical	Fundamental
Peak	 <p>Date: 2016-11-09</p> <p>Site : 03CH12-HY            Condition : PEAK_BE_74 3m HORN_9120D_1328 VERTICAL            : RBW:1000.000KHz VBW:3000.000KHz SWT:Auto            Detector : Peak            Project : 600550            Mode : 12            Setting : 06</p>	Left blank
Avg.	 <p>Date: 2016-11-09</p> <p>Site : 03CH12-HY            Condition : AVG_BE_54 3m HORN_9120D_1328 VERTICAL            : RBW:1000.000KHz VBW:3.000KHz SWT:Auto            Detector : Peak            Project : 600550            Mode : 12            Setting : 06</p>	Left blank

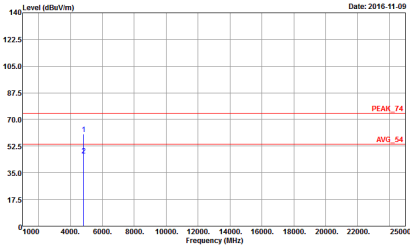
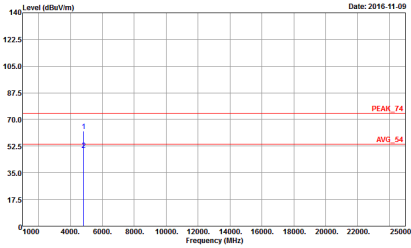

2.4GHz 2400~2483.5MHz  
 WIFI 802.11n HT20 (Harmonic @ 3m)

WIFI	2.4GHz 2400~2483.5MHz Harmonic @ 3m	
ANT	802.11n HT20 CH01 2412MHz	
1+2	Horizontal	Vertical
Peak  Avg.	 <p>           Date: 2016-11-09            Site : 03CH12-HY            Condition : PEAK_74 3m HORN_9120D_1328 HORIZONTAL            Detector : Peak            Project : 600550            Mode : 7            Setting : 0C         </p>	 <p>           Date: 2016-11-09            Site : 03CH12-HY            Condition : PEAK_74 3m HORN_9120D_1328 VERTICAL            Detector : Peak            Project : 600550            Mode : 7            Setting : 0C         </p>

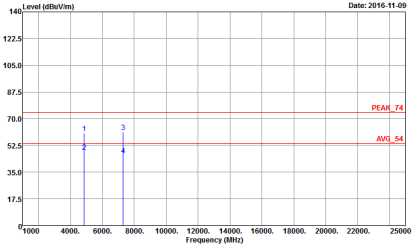
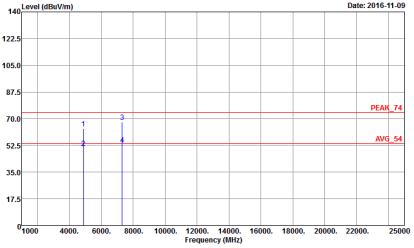

WIFI	2.4GHz 2400~2483.5MHz Harmonic @ 3m	
ANT	802.11n HT20 CH06 2437MHz	
1+2	Horizontal	Vertical
<p>Peak</p> <p>Avg.</p>	 <p>Site : 03CH12-HY          Condition : PEAK_74 3m HORN_9120D_1328 HORIZONTAL          Detector : Peak          Project : 600550          Mode : B          Setting : 0C</p>	 <p>Site : 03CH12-HY          Condition : PEAK_74 3m HORN_9120D_1328 VERTICAL          Detector : Peak          Project : 600550          Mode : B          Setting : 0C</p>

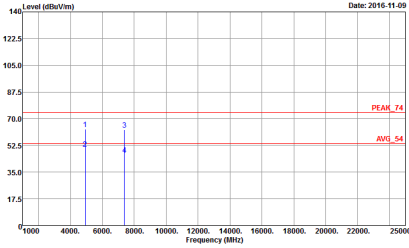
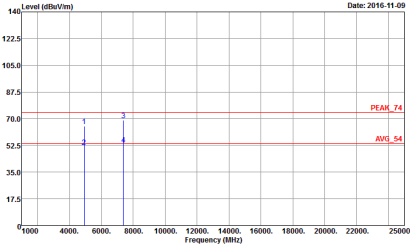

WIFI	2.4GHz 2400~2483.5MHz Harmonic @ 3m	
ANT	802.11n HT20 CH11 2462MHz	
1+2	Horizontal	Vertical
Peak Avg.	 <p>Site : 03CH12-HY Condition : PEAK_74 3m HORN_9120D_1328 HORIZONTAL Detector : Peak Project : 600550 Mode : 9 Setting : 0D</p>	 <p>Site : 03CH12-HY Condition : PEAK_74 3m HORN_9120D_1328 VERTICAL Detector : Peak Project : 600550 Mode : 9 Setting : 0D</p>





**2.4GHz 2400~2483.5MHz**  
**WIFI 802.11n HT40 (Harmonic @ 3m)**

<b>WIFI</b>	<b>2.4GHz 2400~2483.5MHz Harmonic @ 3m</b>	
<b>ANT</b>	<b>802.11n HT40 CH03 2422MHz</b>	
<b>1+2</b>	<b>Horizontal</b>	<b>Vertical</b>
<b>Peak</b> <b>Avg.</b>		



WIFI	2.4GHz 2400~2483.5MHz Harmonic @ 3m	
ANT	802.11n HT40 CH06 2437MHz	
1+2	Horizontal	Vertical
Peak Avg.	<p>Site : 03CH12-HY Condition : PEAK_74 3m HORN_9120D_1328 HORIZONTAL Detector : Peak Project : 600550 Mode : I1 Setting : 0E</p>	<p>Site : 03CH12-HY Condition : PEAK_74 3m HORN_9120D_1328 VERTICAL Detector : Peak Project : 600550 Mode : I1 Setting : 0E</p>

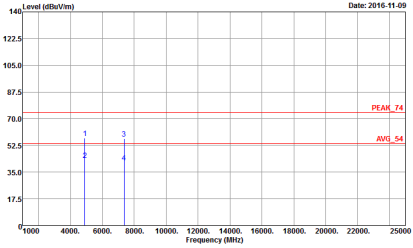
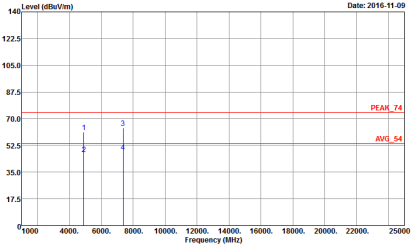

WIFI	2.4GHz 2400~2483.5MHz Harmonic @ 3m																									
ANT	802.11n HT40 CH09 2452MHz																									
1+2	Horizontal	Vertical																								
<b>Peak</b>  <b>Avg.</b>	 <table border="1" data-bbox="347 728 630 795"> <tr><td>Site</td><td>: 03CH12-HY</td></tr> <tr><td>Condition</td><td>: PEAK_74 3m HORN_9120D_1328 HORIZONTAL</td></tr> <tr><td>Detector</td><td>: Peak</td></tr> <tr><td>Project</td><td>: 600550</td></tr> <tr><td>Mode</td><td>: 12</td></tr> <tr><td>Setting</td><td>: 06</td></tr> </table>	Site	: 03CH12-HY	Condition	: PEAK_74 3m HORN_9120D_1328 HORIZONTAL	Detector	: Peak	Project	: 600550	Mode	: 12	Setting	: 06	 <table border="1" data-bbox="944 728 1227 795"> <tr><td>Site</td><td>: 03CH12-HY</td></tr> <tr><td>Condition</td><td>: PEAK_74 3m HORN_9120D_1328 VERTICAL</td></tr> <tr><td>Detector</td><td>: Peak</td></tr> <tr><td>Project</td><td>: 600550</td></tr> <tr><td>Mode</td><td>: 12</td></tr> <tr><td>Setting</td><td>: 06</td></tr> </table>	Site	: 03CH12-HY	Condition	: PEAK_74 3m HORN_9120D_1328 VERTICAL	Detector	: Peak	Project	: 600550	Mode	: 12	Setting	: 06
Site	: 03CH12-HY																									
Condition	: PEAK_74 3m HORN_9120D_1328 HORIZONTAL																									
Detector	: Peak																									
Project	: 600550																									
Mode	: 12																									
Setting	: 06																									
Site	: 03CH12-HY																									
Condition	: PEAK_74 3m HORN_9120D_1328 VERTICAL																									
Detector	: Peak																									
Project	: 600550																									
Mode	: 12																									
Setting	: 06																									



Emission below 1GHz
2.4GHz WIFI 802.11n HT40 (LF)

Table with 2 columns: Horizontal and Vertical. Each column contains a spectral plot of Level (dBuV/m) vs Frequency (MHz) from 30 to 1000 MHz. The plots show emission levels with a red 'QP' peak marker. Metadata includes Site: 03CH12-HY, Condition: QP 3m BIL0G\_6111D\_37059, Detector: Peak, Project: 600550, Mode: 13.



### Appendix D. Duty Cycle Plots

Antenna	Band	Duty Cycle(%)	T(us)	1/T(kHz)	VBW Setting
1	802.11b	97.315	8700	0.114942529	300Hz
2	802.11b	97.694	8640	0.115740741	300Hz
1	802.11g	86.747	1440	0.694444444	1kHz
2	802.11g	87.805	1440	0.694444444	1kHz
1	2.4GHz 802.11n HT20	85.897	1340	0.746268657	1kHz
2	2.4GHz 802.11n HT20	87.013	1340	0.746268657	1kHz
1+2	2.4GHz 802.11n HT20 for Ant 1	85.897	1340	0.746268657	1kHz
1+2	2.4GHz 802.11n HT20 for Ant 2	85.897	1340	0.746268657	1kHz
1	2.4GHz 802.11n HT40	77.01	670	1.492537313	3kHz
2	2.4GHz 802.11n HT40	72.727	640	1.5625	3kHz
1+2	2.4GHz 802.11n HT40 for Ant 1	76.136	670	1.492537313	3kHz
1+2	2.4GHz 802.11n HT40 for Ant 2	75.862	660	1.515151515	3kHz

<Ant. 1>

802.11b

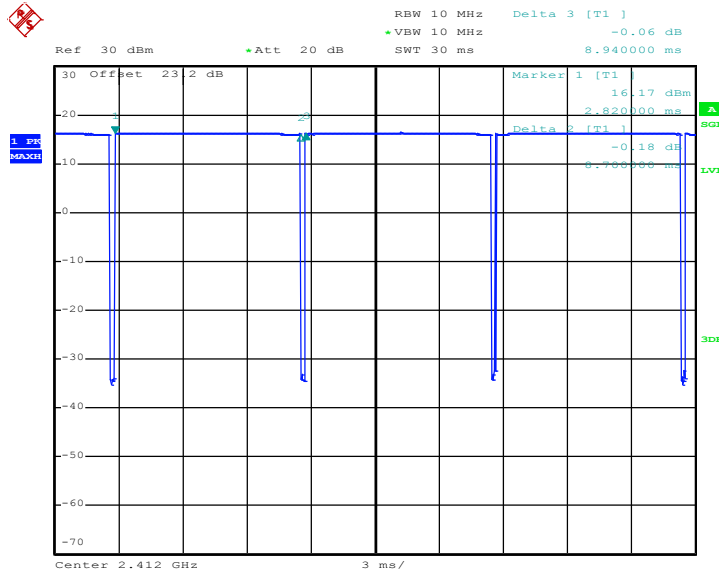

Date: 10.NOV.2016 22:10:36

802.11g

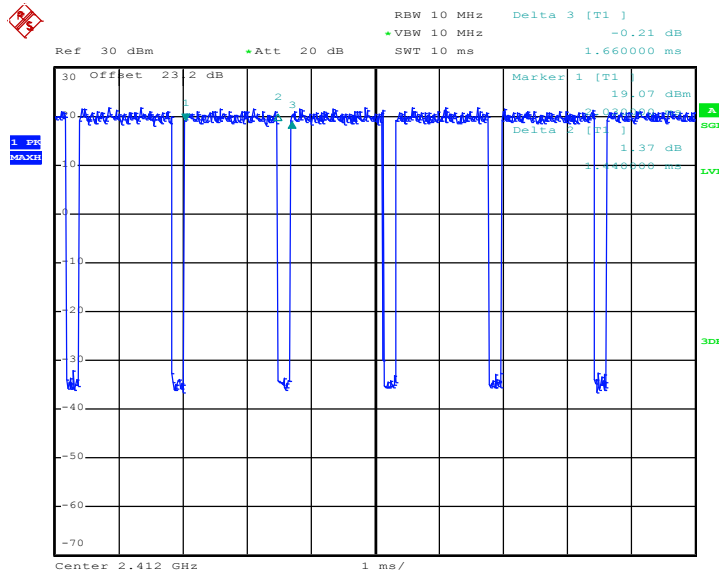

Date: 10.NOV.2016 22:37:13



802.11n HT20

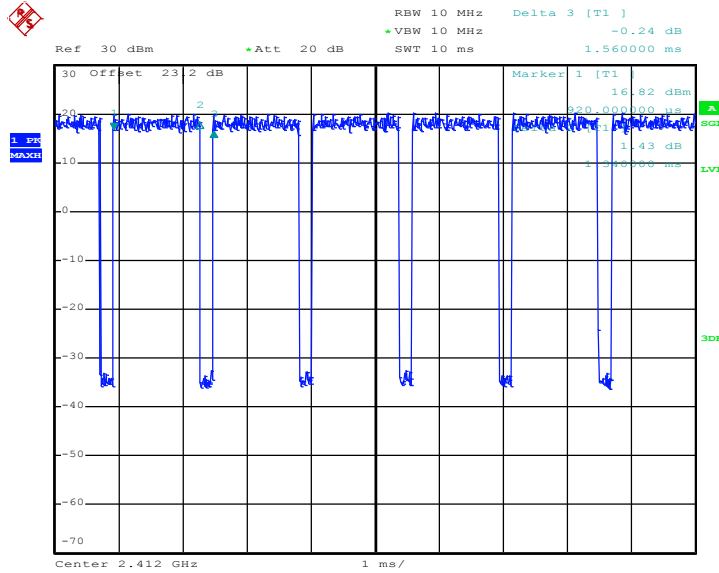

Date: 10.NOV.2016 22:46:13

802.11n HT40

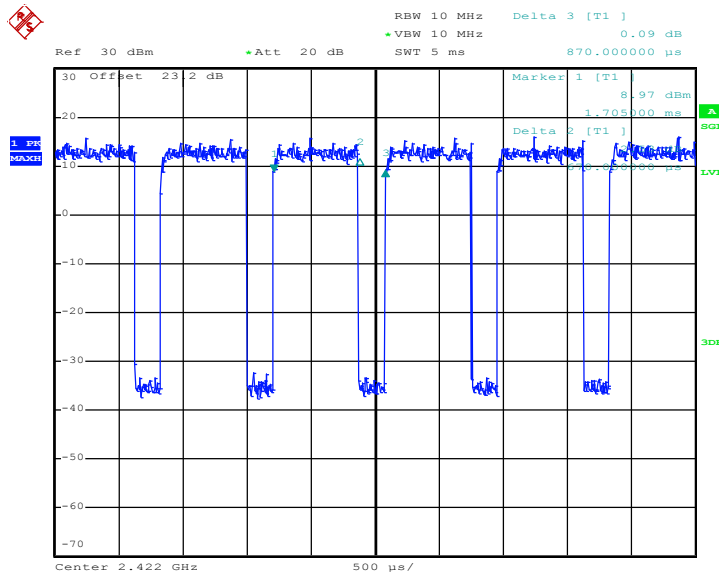

Date: 10.NOV.2016 22:53:45



<Ant. 2>

802.11b

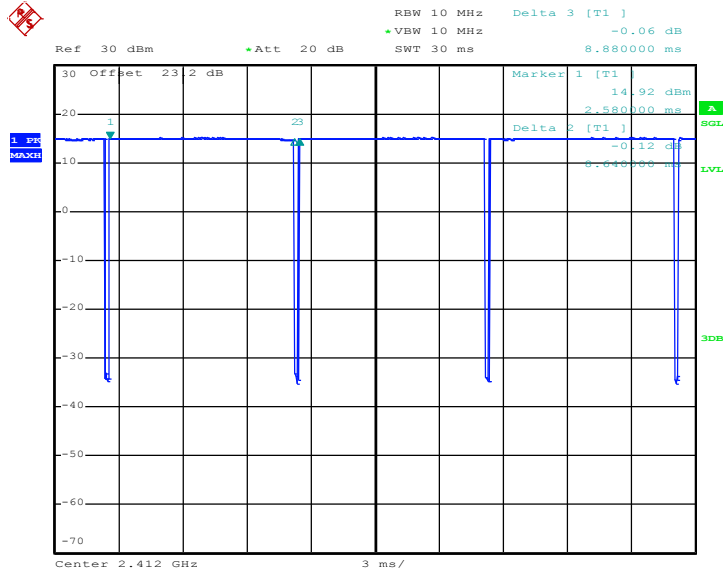

Date: 10.NOV.2016 22:34:49

802.11g

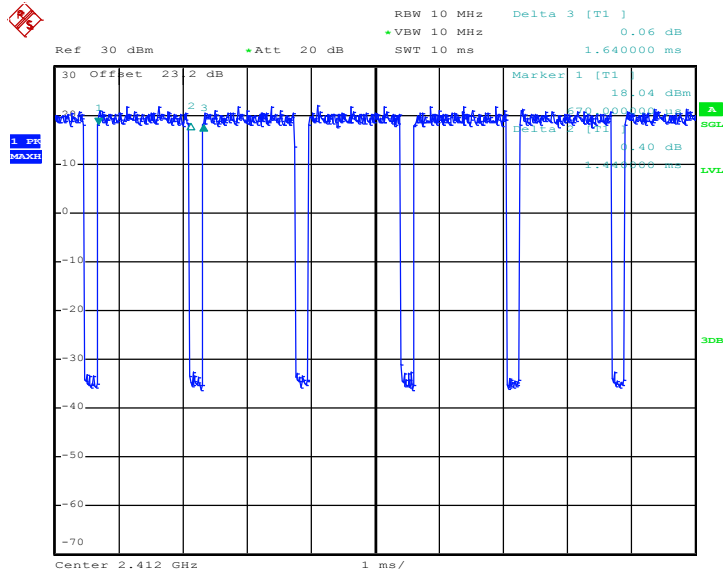

Date: 10.NOV.2016 22:38:22





802.11n HT20

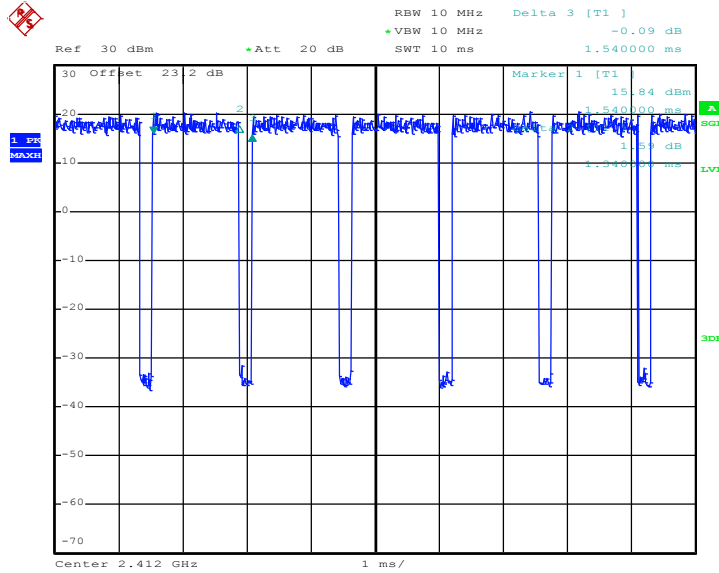

Date: 10.NOV.2016 22:43:04

802.11n HT40

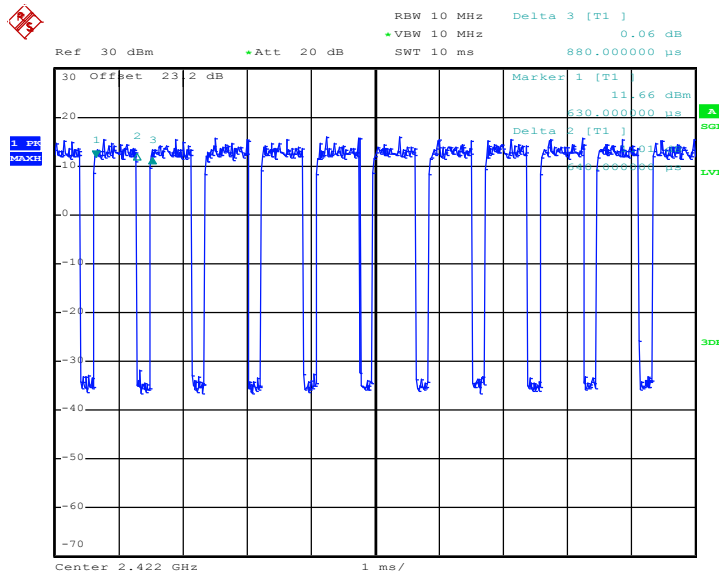

Date: 10.NOV.2016 22:58:41



MIMO <Ant. 1+2(1)>

802.11n HT20

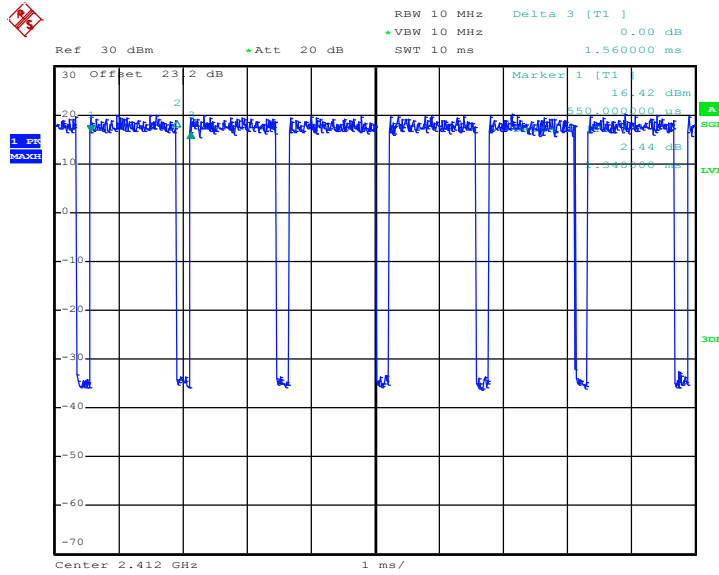

Date: 10.NOV.2016 22:44:49

802.11n HT40

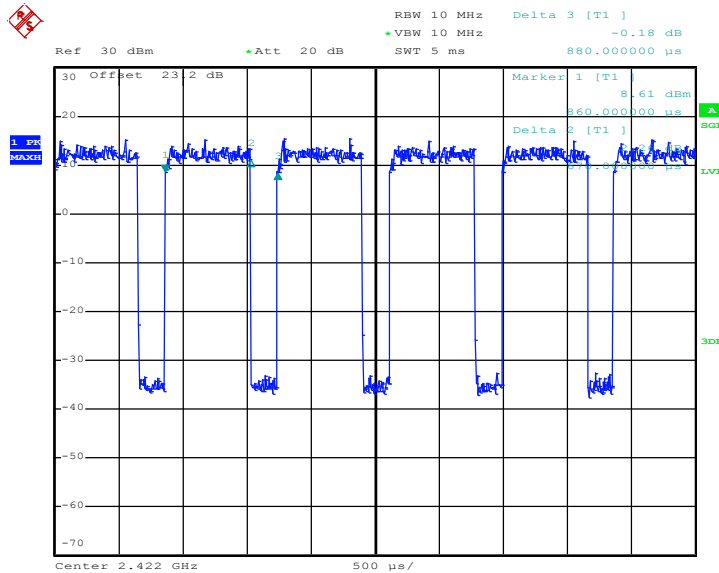

Date: 10.NOV.2016 22:55:41



MIMO <Ant. 1+2(2)>

802.11n HT20

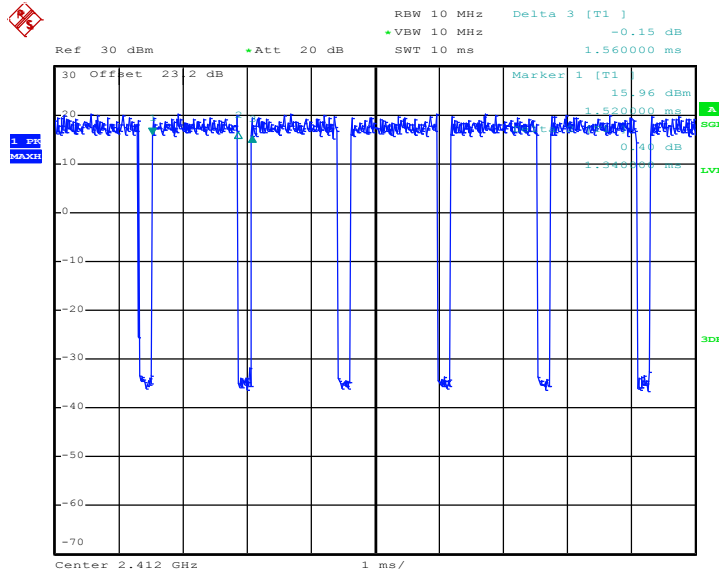

Date: 10.NOV.2016 22:43:58

802.11n HT40

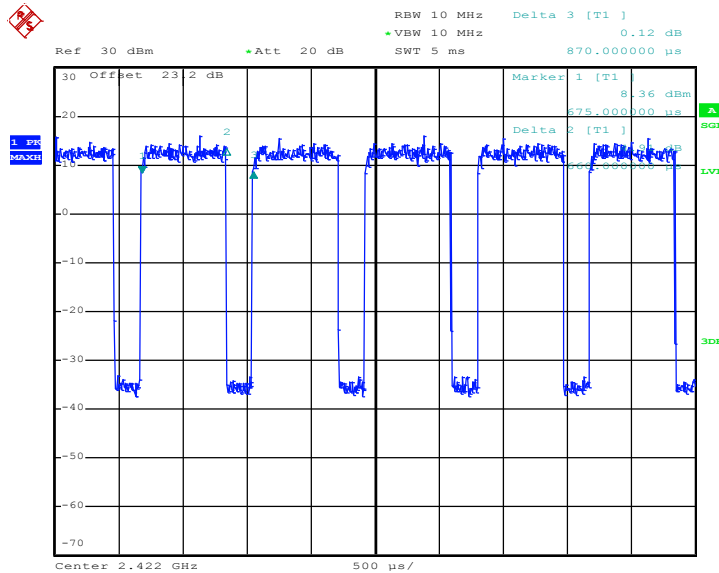

Date: 10.NOV.2016 22:56:20