



# FCC TEST REPORT

**REPORT NO.:** RF110302E02

**MODEL NO.:** DWR-117, DWR-112

**FCC ID:** KA2WR117A1

**RECEIVED:** Mar. 02, 2011

**TESTED:** Mar. 11 to Apr. 07, 2011

**ISSUED:** May 06, 2011

**APPLICANT:** D-Link Corporation

**ADDRESS:** No.289, Sinhu 3rd Rd., Neihu District, Taipei City 114,  
Taiwan, R.O.C.

**ISSUED BY:** Bureau Veritas Consumer Products Services (H.K.)  
Ltd., Taoyuan Branch Hsin Chu Laboratory

**LAB ADDRESS :** No. 81-1, Lu Liao Keng, 9th Ling,Wu Lung Tsuen,  
Chiung Lin Hsiang, Hsin Chu Hsien 307, Taiwan

**TEST LOCATION (1):** No. 81-1, Lu Liao Keng, 9th Ling,Wu Lung Tsuen,  
Chiung Lin Hsiang, Hsin Chu Hsien 307, Taiwan

**TEST LOCATION (2):** No. 49, Ln. 206, Wende Rd., Shangshan Tsuen, Chiung  
Lin Hsiang, Hsin Chu Hsien 307, Taiwan

This test report consists of 80 pages in total. It may be duplicated completely for legal use with the approval of the applicant. It should not be reproduced except in full, without the written approval of our laboratory. The client should not use it to claim product certification, approval, or endorsement by TAF or any government agencies. The test results in the report only apply to the tested sample.





A D T

## Table of Contents

RELEASE CONTROL RECORD.....	4
1. CERTIFICATION.....	5
2. SUMMARY OF TEST RESULTS.....	6
2.1 MEASUREMENT UNCERTAINTY .....	7
3. GENERAL INFORMATION .....	8
3.1 GENERAL DESCRIPTION OF EUT .....	8
3.2 DESCRIPTION OF TEST MODES .....	10
3.2.1 TEST MODE APPLICABILITY AND TESTED CHANNEL DETAIL.....	11
3.3 GENERAL DESCRIPTION OF APPLIED STANDARDS.....	13
3.4 DESCRIPTION OF SUPPORT UNITS.....	14
3.5 CONFIGURATION OF SYSTEM UNDER TEST .....	15
4. TEST TYPES AND RESULTS.....	17
4.1 CONDUCTED EMISSION MEASUREMENT .....	17
4.1.1 LIMITS OF CONDUCTED EMISSION MEASUREMENT .....	17
4.1.2 TEST INSTRUMENTS .....	17
4.1.3 TEST PROCEDURES.....	18
4.1.4 DEVIATION FROM TEST STANDARD .....	18
4.1.5 TEST SETUP .....	19
4.1.6 EUT OPERATING CONDITIONS.....	19
4.1.7 TEST RESULTS (MODE 1).....	20
4.1.8 TEST RESULTS (MODE 2).....	22
4.2 RADIATED EMISSION MEASUREMENT .....	24
4.2.1 LIMITS OF RADIATED EMISSION MEASUREMENT .....	24
4.2.2 TEST INSTRUMENTS .....	25
4.2.3 TEST PROCEDURES.....	27
4.2.4 DEVIATION FROM TEST STANDARD .....	27
4.2.5 TEST SETUP .....	28
4.2.6 EUT OPERATING CONDITIONS.....	28
4.2.7 TEST RESULTS.....	29
4.3 6DB BANDWIDTH MEASUREMENT .....	58
4.3.1 LIMITS OF 6DB BANDWIDTH MEASUREMENT .....	58
4.3.2 TEST INSTRUMENTS .....	58
4.3.3 TEST PROCEDURE .....	58
4.3.4 DEVIATION FROM TEST STANDARD .....	58
4.3.5 TEST SETUP .....	58
4.3.6 EUT OPERATING CONDITIONS.....	58
4.3.7 TEST RESULTS.....	59
4.4 MAXIMUM PEAK OUTPUT POWER .....	63
4.4.1 LIMITS OF MAXIMUM PEAK OUTPUT POWER MEASUREMENT.....	63



A D T

4.4.2	INSTRUMENTS .....	63
4.4.3	TEST PROCEDURES.....	63
4.4.4	DEVIATION FROM TEST STANDARD .....	63
4.4.5	TEST SETUP .....	63
4.4.6	EUT OPERATING CONDITIONS.....	63
4.4.7	TEST RESULTS.....	64
4.5	POWER SPECTRAL DENSITY MEASUREMENT .....	65
4.5.1	LIMITS OF POWER SPECTRAL DENSITY MEASUREMENT .....	65
4.5.2	TEST INSTRUMENTS .....	65
4.5.3	TEST PROCEDURE .....	65
4.5.4	DEVIATION FROM TEST STANDARD .....	65
4.5.5	TEST SETUP .....	65
4.5.6	EUT OPERATING CONDITION .....	65
4.5.7	TEST RESULTS.....	66
4.6	CONDUCTED OUT-BAND EMISSION MEASUREMENT .....	70
4.6.1	LIMITS OF CONDUCTED OUT-BAND EMISSION MEASUREMENT .....	70
4.6.2	TEST INSTRUMENTS .....	70
4.6.3	TEST PROCEDURE .....	70
4.6.4	DEVIATION FROM TEST STANDARD .....	70
4.6.5	EUT OPERATING CONDITION .....	70
4.6.6	TEST RESULTS.....	70
5.	INFORMATION ON THE TESTING LABORATORIES.....	79
6.	APPENDIX A - MODIFICATIONS RECORDERS FOR ENGINEERING CHANGES TO THE EUT BY THE LAB.....	80



A D T

## RELEASE CONTROL RECORD

ISSUE NO.	REASON FOR CHANGE	DATE ISSUED
RF110302E02	Original release	May 06, 2011



A D T

## 1. CERTIFICATION

**PRODUCT:** 3G WiFi 11N Router with miiiCasa home gateway  
**BRAND NAME:** D-Link  
**MODEL NO.:** DWR-117, DWR-112  
**TEST SAMPLE:** MASS-PRODUCTION  
**TESTED:** Mar. 11 to Apr. 07, 2011  
**APPLICANT:** D-Link Corporation  
**STANDARDS:** FCC Part 15, Subpart C (Section 15.247)  
ANSI C63.4-2003  
ANSI C63.10-2009

The above equipment (Model: DWR-117) has been tested by **Bureau Veritas Consumer Products Services (H.K.) Ltd., Taoyuan Branch**, and found compliance with the requirement of the above standards. The test record, data evaluation & Equipment Under Test (EUT) configurations represented herein are true and accurate accounts of the measurements of the sample's EMC characteristics under the conditions specified in this report.

**PREPARED BY** : Carol Liao , **DATE:** May 06, 2011  
( Carol Liao, Specialist )

**APPROVED BY** : May Chen , **DATE:** May 06, 2011  
( May Chen, Deputy Manager )

## 2. SUMMARY OF TEST RESULTS

The EUT has been tested according to the following specifications:

<b>APPLIED STANDARD: FCC Part 15, Subpart C</b>			
<b>Standard Section</b>	<b>Test Type and Limit</b>	<b>Result</b>	<b>Remark</b>
15.207	AC Power Conducted Emission	PASS	Meet the requirement of limit. Minimum passing margin is -15.28dB at 20.867MHz
15.247(a)(2)	Spectrum Bandwidth of a Direct Sequence Spread Spectrum System Limit: min. 500kHz	PASS	Meet the requirement of limit.
15.247(b)	Maximum Peak Output Power Limit: max. 30dBm	PASS	Meet the requirement of limit.
15.247(d)	Radiated Emissions Limit: Table 15.209	PASS	Meet the requirement of limit. Minimum passing margin is -0.6dB at 2483.50MHz & 4874.00MHz
15.247(e)	Power Spectral Density Limit: max. 8dBm	PASS	Meet the requirement of limit.
15.247(d)	Conducted Out-Band Emission Measurement Limit: 20dB less than the peak value of fundamental frequency	PASS	Meet the requirement of limit.
15.203	Antenna Requirement	PASS	No antenna connector is used.



A D T

## 2.1 MEASUREMENT UNCERTAINTY

Where relevant, the following measurement uncertainty levels have been estimated for tests performed on the EUT as specified in CISPR 16-4-2:

This uncertainty represents an expanded uncertainty expressed at approximately the 95% confidence level using a coverage factor of  $k=2$ .

Measurement	Value
Conducted emissions	2.45 dB
Radiated emissions (30MHz-1GHz)	3.30 dB
Radiated emissions (1GHz -18GHz)	2.19 dB
Radiated emissions (18GHz -40GHz)	2.55 dB



A D T

### 3. GENERAL INFORMATION

#### 3.1 GENERAL DESCRIPTION OF EUT

<b>PRODUCT</b>	3G WiFi 11N Router with miiiCasa home gateway
<b>MODEL NO.</b>	DWR-117, DWR-112
<b>FCC ID</b>	KA2WR117A1
<b>POWER SUPPLY</b>	DC 5V from power adapter
<b>MODULATION TYPE</b>	CCK, DQPSK, DBPSK for DSSS 64QAM, 16QAM, QPSK, BPSK for OFDM
<b>MODULATION TECHNOLOGY</b>	DSSS, OFDM
<b>TRANSFER RATE</b>	802.11b: 11 / 5.5 / 2 / 1Mbps 802.11g: 54 / 48 / 36 / 24 / 18 / 12 / 9 / 6Mbps HT20 MCS0~7 (800ns GI): 6.5Mbps, 13Mbps, 19.5Mbps, 26Mbps, 39Mbps, 52Mbps, 58.5Mbps, 65Mbps, HT20 MCS8~15 (800ns GI): 13Mbps, 26Mbps, 39Mbps, 52Mbps, 78Mbps, 104Mbps, 117Mbps, 130Mbps, HT40 MCS0~7 (800ns GI): 13.5Mbps, 27Mbps, 40.5Mbps, 54Mbps, 81Mbps, 108Mbps, 121.5Mbps, 135Mbps. HT40 MCS8~15 (800ns GI): 27Mbps, 54Mbps, 81Mbps, 108Mbps, 162Mbps, 216Mbps, 243Mbps, 270Mbps. HT20 MCS0~7 (400ns GI): 7.2Mbps, 14.4Mbps, 21.7Mbps, 28.9Mbps, 43.3Mbps, 57.8Mbps, 65.0Mbps, 72.2Mbps HT20 MCS8~15 (400ns GI): 14.444Mbps, 28.889Mbps, 43.333Mbps, 57.778Mbps, 86.667Mbps, 115.556Mbps, 130.000Mbps, 1444.444Mbps HT40 MCS0~7 (400ns GI): 15.0Mbps, 30.0Mbps, 45.0Mbps, 60.0Mbps, 90.0Mbps, 120.0Mbps, 135.0Mbps, 150.0Mbps HT40 MCS8~15 (400ns GI): 30.0Mbps, 60.0Mbps, 90.0Mbps, 120.0Mbps, 180.0Mbps, 240.0Mbps, 270.0Mbps, 300.0Mbps
<b>FREQUENCY RANGE</b>	2412MHz ~ 2462MHz
<b>NUMBER OF CHANNEL</b>	11 for 802.11b, 802.11g, 802.11n (20MHz) 7 for 802.11n (40MHz)
<b>MAXIMUM OUTPUT POWER</b>	802.11b: 93.3mW 802.11g: 229.1mW 802.11n (20MHz): 351.6mW 802.11n (40MHz): 328.1mW
<b>ANTENNA TYPE</b>	Please see NOTE
<b>DATA CABLE</b>	Ethernet cable x 1(Unshielded,1.5m)
<b>I/O PORTS</b>	USB port x 2 Ethernet port x 4 (Ethernet: 10, 100Mbps)
<b>ASSOCIATED DEVICES</b>	Adapter x 1



**NOTE:**

1. The EUT has two model names which are identical to each other in all aspects except for the following table:

Brand	Model Name	Description
D-Link	DWR-117	FLASH: 8MB
	DWR-112	FLASH: 4MB

From the above models, model: **DWR-117** was selected as representative model for the test and its data was recorded in this report.

2. There are two antennas provided to this EUT, please refer to the following table:

Transmitter Circuit	Manufacturer	Model name	Peak Gain (Included Cable loss)	Antenna Type	Connector Type
Chain (0)	MAG. LAYERS SCIENTIFIC-TECHNICS CO., LTD	MSA-2005-2G4C1-A3	1.1dBi	PIFA	NA
Chain (1)		MSA-2005-2G4C1-A2	2.91dBi	PIFA	NA

3. The EUT incorporates a MIMO function with 802.11n.  
 4. The EUT is 2 \* 2 spatial MIMO (2Tx & 2Rx) without beam forming function. The 11b/g legacy mode is limited to single transmitter only.  
 5. When the EUT operating in 802.11n, the software operation, which is defined by manufacturer, MCS (Modulation and Coding Schemes) from 0 to 15.  
 6. The EUT must be supplied with a power adapter and following two different model names could be chosen:

Adapter	Manufacturer	Brand	Model No.	Spec.
Adapter 1	AMIGO	D-Link	AMS3-0502500FU	AC Input: 100-240V 0.5A, 50/60Hz DC Output: 5V, 2.5A DC Cable: 1.5m (unshielded)
Adapter 2			AMS3-0502500SU	AC Input: 100-120V 0.5A, 60Hz DC Output: 5V, 2.5A DC Cable: 1.5m (unshielded)

The worst radiated emission was found in **Adapter 1**. Therefore only the test data of the mode was recorded in this report.

7. The EUT could be applied with one 3G USB dongle, therefore the spurious emission of the simultaneous operation (WLAN & 3G USB dongle) has been evaluated and no non-compliance found. <only for test, not for sale>

No.	Brand name	Model name	FCC ID
1	D-Link	DWM-156	KA2WM156
2	D-Link	DWM-152	KA2WM152
3	HUAWEI	E180	QISE180



A D T

8. The above EUT information was declared by manufacturer and for more detailed features description, please refer to the manufacturer's specifications or user's manual.

### 3.2 DESCRIPTION OF TEST MODES

Eleven channels are provided for 802.11b, 802.11g, 802.11n (20MHz):

CHANNEL	FREQUENCY	CHANNEL	FREQUENCY
1	2412MHz	7	2442MHz
2	2417MHz	8	2447MHz
3	2422MHz	9	2452MHz
4	2427MHz	10	2457MHz
5	2432MHz	11	2462MHz
6	2437MHz		

Seven channels are provided for 802.11n (40MHz):

CHANNEL	FREQUENCY	CHANNEL	FREQUENCY
3	2422MHz	7	2442MHz
4	2427MHz	8	2447MHz
5	2432MHz	9	2452MHz
6	2437MHz		

### 3.2.1 TEST MODE APPLICABILITY AND TESTED CHANNEL DETAIL

EUT CONFIGURE MODE	APPLICABLE TO				DESCRIPTION
	PLC	RE < 1G	RE ≥ 1G	APCM	
MODE 1	√	√	√	√	With adapter 1
MODE 2	√	-	-	-	With adapter 2

Where **PLC**: Power Line Conducted Emission      **RE < 1G**: Radiated Emission below 1GHz  
**RE ≥ 1G**: Radiated Emission above 1GHz      **APCM**: Antenna Port Conducted Measurement

#### **POWER LINE CONDUCTED EMISSION TEST:**

- Pre-Scan has been conducted to determine the worst-case mode from all possible combinations between available modulations, data rates and antenna ports (if EUT with antenna diversity architecture).
- Following channel(s) was (were) selected for the final test as listed below.

MODE	AVAILABLE CHANNEL	TESTED CHANNEL	MODULATION TECHNOLOGY	MODULATION TYPE	DATA RATE (Mbps)
802.11n (20MHz)	1 to 11	6	OFDM	BPSK	6.5

#### **RADIATED EMISSION TEST (BELOW 1 GHz):**

- Pre-Scan has been conducted to determine the worst-case mode from all possible combinations between available modulations, data rates and antenna ports (if EUT with antenna diversity architecture).
- Following channel(s) was (were) selected for the final test as listed below.

MODE	AVAILABLE CHANNEL	TESTED CHANNEL	MODULATION TECHNOLOGY	MODULATION TYPE	DATA RATE (Mbps)
802.11n (20MHz)	1 to 11	6	OFDM	BPSK	6.5



A D T

**RADIATED EMISSION TEST (ABOVE 1 GHz):**

- Pre-Scan has been conducted to determine the worst-case mode from all possible combinations between available modulations, data rates and antenna ports (if EUT with antenna diversity architecture).
- Following channel(s) was (were) selected for the final test as listed below.

MODE	AVAILABLE CHANNEL	TESTED CHANNEL	MODULATION TECHNOLOGY	MODULATION TYPE	DATA RATE (Mbps)
802.11b	1 to 11	1, 6, 11	DSSS	DBPSK	1
802.11g	1 to 11	1, 6, 11	OFDM	BPSK	6
802.11n (20MHz)	1 to 11	1, 6, 11	OFDM	BPSK	6.5
802.11n (40MHz)	3 to 9	3, 6, 9	OFDM	BPSK	13.5

**CONDUCTED OUT-BAND EMISSION MEASUREMENT:**

- Pre-Scan has been conducted to determine the worst-case mode from all possible combinations between available modulations, data rates and antenna ports (if EUT with antenna diversity architecture).
- Following channel(s) was (were) selected for the final test as listed below.

MODE	AVAILABLE CHANNEL	TESTED CHANNEL	MODULATION TECHNOLOGY	MODULATION TYPE	DATA RATE (Mbps)
802.11b	1 to 11	1, 11	DSSS	DBPSK	1
802.11g	1 to 11	1, 11	OFDM	BPSK	6
802.11n (20MHz)	1 to 11	1, 11	OFDM	BPSK	6.5
802.11n (40MHz)	3 to 9	3, 9	OFDM	BPSK	13.5

※ Conducted out band emission as show worst chain in report base on preliminary measurement.

### **ANTENNA PORT CONDUCTED MEASUREMENT:**

- This item includes all test value of each mode, but only includes spectrum plot of worst value of each mode.
- Pre-Scan has been conducted to determine the worst-case mode from all possible combinations between available modulations, data rates and antenna ports (if EUT with antenna diversity architecture).
- Following channel(s) was (were) selected for the final test as listed below.

MODE	AVAILABLE CHANNEL	TESTED CHANNEL	MODULATION TECHNOLOGY	MODULATION TYPE	DATA RATE (Mbps)
802.11b	1 to 11	1, 6, 11	DSSS	DBPSK	1
802.11g	1 to 11	1, 6, 11	OFDM	BPSK	6
802.11n (20MHz)	1 to 11	1, 6, 11	OFDM	BPSK	6.5
802.11n (40MHz)	3 to 9	3, 6, 9	OFDM	BPSK	13.5

※ Bandwidth as show worst chain in report base on preliminary measurement.

### **TEST CONDITION:**

APPLICABLE TO	ENVIRONMENTAL CONDITIONS	INPUT POWER	TESTED BY
RE <sup>3</sup> 1G	21deg. C, 66%RH, 1023 hPa	120Vac, 60Hz	Frank Liu
RE<1G	16deg. C, 67%RH, 1023 hPa	120Vac, 60Hz	Frank Liu
PLC	22deg. C, 71%RH, 1023 hPa	120Vac, 60Hz	Andy Chen
APCM	25deg. C, 60%RH, 1023 hPa	120Vac, 60Hz	Rex Huang

### **3.3 GENERAL DESCRIPTION OF APPLIED STANDARDS**

The EUT is a RF product. According to the specifications of the manufacturer, it must comply with the requirements of the following standards:

**FCC Part 15, Subpart C. (15.247)**

**ANSI C63.4-2003**

**ANSI C63.10-2009**

All test items have been performed and recorded as per the above standards.

**NOTE:** The EUT has been verified to comply with the requirements of FCC Part 15, Subpart B, Class B (DoC). The test report has been issued separately.



A D T

### 3.4 DESCRIPTION OF SUPPORT UNITS

The EUT has been tested as an independent unit together with other necessary accessories or support units. The following support units or accessories were used to form a representative test configuration during the tests.

NO.	PRODUCT	BRAND	MODEL NO.	SERIAL NO.	FCC ID
1	NOTEBOOK COMPUTER	DELL	PP32LA	FSLB32S	FCC DoC
2	NOTEBOOK COMPUTER (for conducted)	DELL	PP32LA	GSLB32S	FCC DoC
3	HUB	ZyXEL	ES-116P	S060H0200021 5	FCC DoC
4	iPod shuffle	Apple	MC749TA/A	CC4DMFKUDF DM	NA
	USB Flash Drive (for conducted)	SanDisk	SDCZ2-512-A10	5472260816	FCC DoC
5	3G USB DONGLE	HUAWEI	E180	NA	QISE180

NO.	SIGNAL CABLE DESCRIPTION OF THE ABOVE SUPPORT UNITS
1	UTP cable, 10m
2	NA
3	UTP cable, 10m
4	USB cable, 0.1m
	NA
5	NA

**NOTE:** 1. All power cords of the above support units are non shielded (1.8m).

### 3.5 CONFIGURATION OF SYSTEM UNDER TEST

For Conducted Emission test:

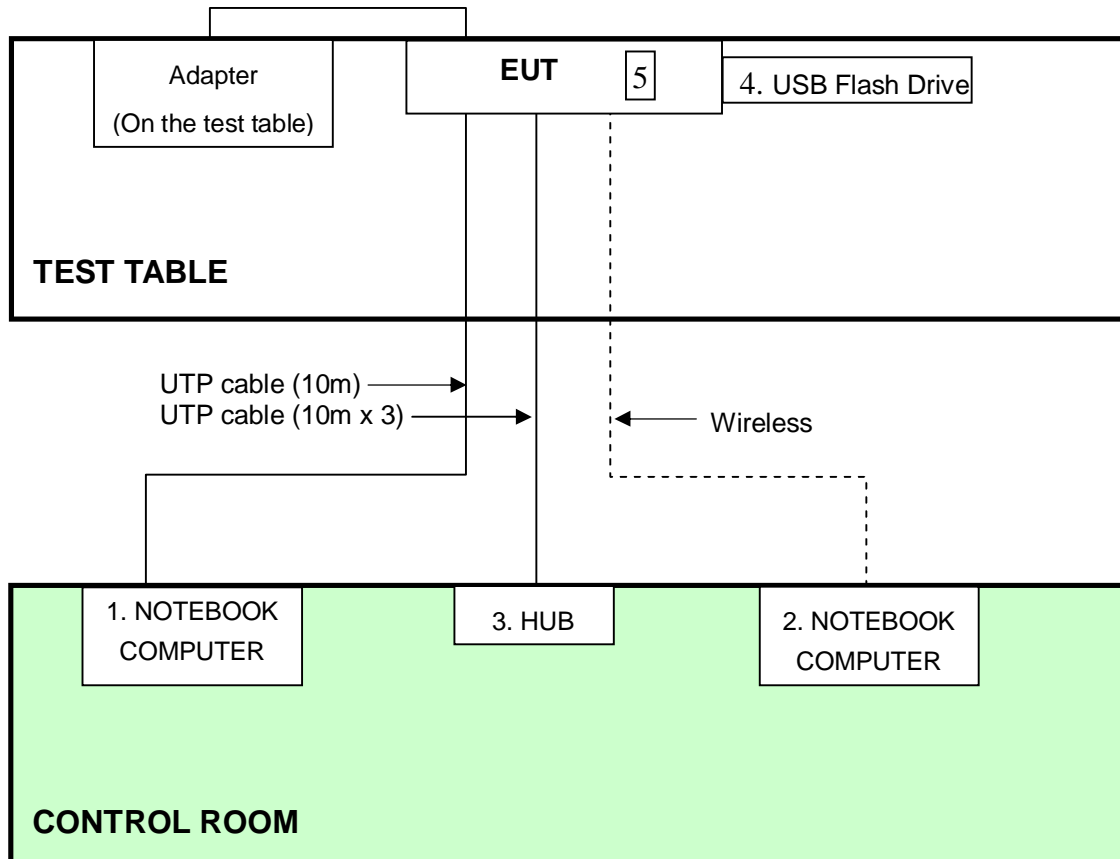

**For other test items:**

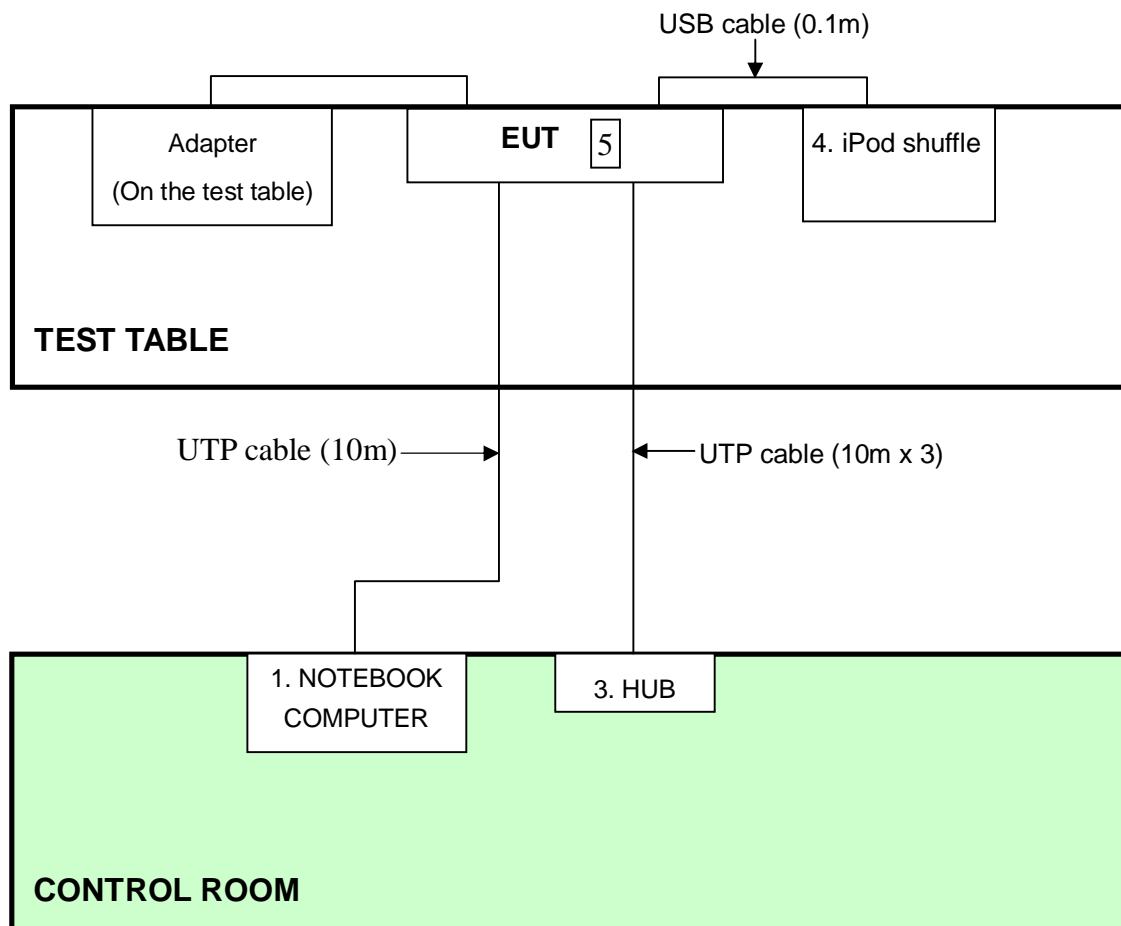



## 4. TEST TYPES AND RESULTS

### 4.1 CONDUCTED EMISSION MEASUREMENT

#### 4.1.1 LIMITS OF CONDUCTED EMISSION MEASUREMENT

FREQUENCY OF EMISSION (MHz)	CONDUCTED LIMIT (dB $\mu$ V)	
	Quasi-peak	Average
0.15-0.5	66 to 56	56 to 46
0.5-5	56	46
5-30	60	50

- NOTE:**
1. The lower limit shall apply at the transition frequencies.
  2. The limit decreases in line with the logarithm of the frequency in the range of 0.15 to 0.50 MHz.
  3. All emanations from a class A/B digital device or system, including any network of conductors and apparatus connected thereto, shall not exceed the level of field strengths specified above.

#### 4.1.2 TEST INSTRUMENTS

DESCRIPTION & MANUFACTURER	MODEL NO.	SERIAL NO.	CALIBRATED DATE	CALIBRATED UNTIL
Test Receiver	ESCS 30	100375	Mar. 09, 2011	Mar. 08, 2012
Line-Impedance Stabilization Network (for EUT)	NSLK 8127	8127-522	Sep. 08, 2010	Sep. 07, 2011
Line-Impedance Stabilization Network (for Peripheral)	ESH3-Z5	848773/004	Nov. 03, 2010	Nov. 02, 2011
RF Cable (JYEBAO)	5DFB	COCCAB-002	Aug. 30, 2010	Aug. 29, 2011
50 ohms Terminator	50	3	Nov. 03, 2010	Nov. 02, 2011
Software	BV ADT_Cond_V7.3.7	NA	NA	NA

**Note:**

1. The calibration interval of the above test instruments is 12 months and the calibrations are traceable to NML/ROC and NIST/USA.
2. The test was performed in Shielded Room No. C.
3. The VCCI Con C Registration No. is C-3611.



A D T

#### 4.1.3 TEST PROCEDURES

- a. The EUT was placed 0.4 meters from the conducting wall of the shielded room with EUT being connected to the power mains through a line impedance stabilization network (LISN). Other support units were connected to the power mains through another LISN. The two LISNs provide 50 ohm/ 50uH of coupling impedance for the measuring instrument.
- b. Both lines of the power mains connected to the EUT were checked for maximum conducted interference.
- c. The frequency range from 150kHz to 30MHz was searched. Emission levels under (Limit - 20dB) were not recorded.

#### 4.1.4 DEVIATION FROM TEST STANDARD

No deviation

#### 4.1.5 TEST SETUP

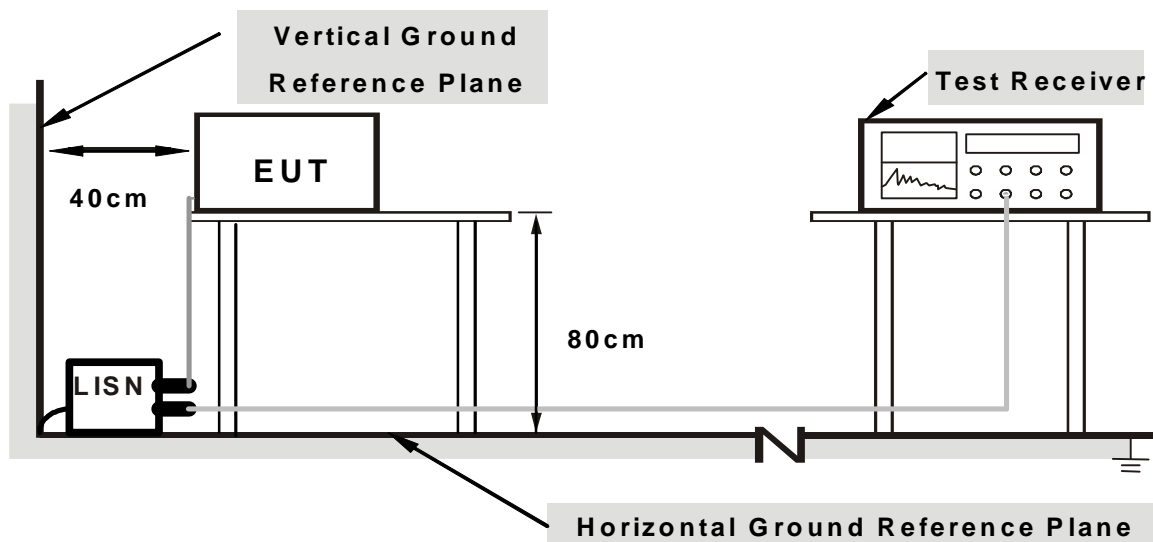

**Note: 1. Support units were connected to second LISN.**

**2. Both of LISNs (AMN) are 80 cm from EUT and at least 80 from other units and other metal planes**

For the actual test configuration, please refer to the related item – Photographs of the Test Configuration.

#### 4.1.6 EUT OPERATING CONDITIONS

1. Turn on the power of all equipment.
2. Support units 1 ~ 2 (Notebook Computer) run a test program “Ping.exe” to enable of EUT via UTP cables and wireless continuously.

### 4.1.7 TEST RESULTS (MODE 1)

<b>PHASE</b>	Line (L)	<b>6dB BANDWIDTH</b>	9 kHz
--------------	----------	----------------------	-------

No	Freq. [MHz]	Corr. Factor (dB)	Reading Value		Emission Level		Limit		Margin	
			[dB (uV)]		[dB (uV)]		[dB (uV)]		(dB)	
			Q.P.	AV.	Q.P.	AV.	Q.P.	AV.	Q.P.	AV.
1	0.150	0.10	45.55	36.00	45.65	36.10	66.00	56.00	-20.35	-19.90
2	0.177	0.12	29.71	8.60	29.83	8.72	64.61	54.61	-34.78	-45.89
3	0.193	0.13	34.60	20.60	34.73	20.73	63.91	53.91	-29.18	-33.18
4	0.439	0.13	30.78	20.73	30.91	20.86	57.08	47.08	-26.17	-26.22
5	4.250	0.21	31.00	26.50	31.21	26.71	56.00	46.00	-24.79	-19.29
6	21.145	0.70	33.11	28.29	33.81	28.99	60.00	50.00	-26.19	-21.01

- REMARKS:**
1. Q.P. and AV. are abbreviations of quasi-peak and average individually.
  2. "-": The Quasi-peak reading value also meets average limit and measurement with the average detector is unnecessary.
  3. The emission levels of other frequencies were very low against the limit.
  4. Margin value = Emission level - Limit value
  5. Correction factor = Insertion loss + Cable loss
  6. Emission Level = Correction Factor + Reading Value.

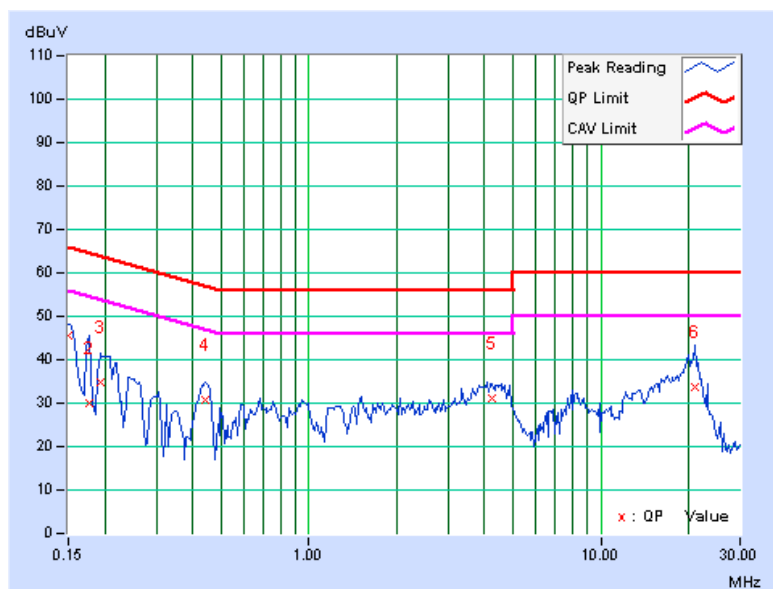

<b>PHASE</b>	Neutral (N)	<b>6dB BANDWIDTH</b>	9 kHz
--------------	-------------	----------------------	-------

No	Freq. [MHz]	Corr. Factor (dB)	Reading Value		Emission Level		Limit		Margin	
			[dB (uV)]		[dB (uV)]		[dB (uV)]		(dB)	
			Q.P.	AV.	Q.P.	AV.	Q.P.	AV.	Q.P.	AV.
1	0.150	0.12	44.24	36.99	44.36	37.11	66.00	56.00	-21.64	-18.89
2	0.181	0.13	33.13	10.45	33.26	10.58	64.43	54.43	-31.17	-43.85
3	0.435	0.15	28.72	17.74	28.87	17.89	57.15	47.15	-28.28	-29.26
4	1.887	0.19	25.77	20.70	25.96	20.89	56.00	46.00	-30.04	-25.11
5	4.125	0.29	31.55	27.13	31.84	27.42	56.00	46.00	-24.16	-18.58
6	20.012	1.42	32.99	28.34	34.41	29.76	60.00	50.00	-25.59	-20.24

- REMARKS:**
1. Q.P. and AV. are abbreviations of quasi-peak and average individually.
  2. "-": The Quasi-peak reading value also meets average limit and measurement with the average detector is unnecessary.
  3. The emission levels of other frequencies were very low against the limit.
  4. Margin value = Emission level - Limit value
  5. Correction factor = Insertion loss + Cable loss
  6. Emission Level = Correction Factor + Reading Value.

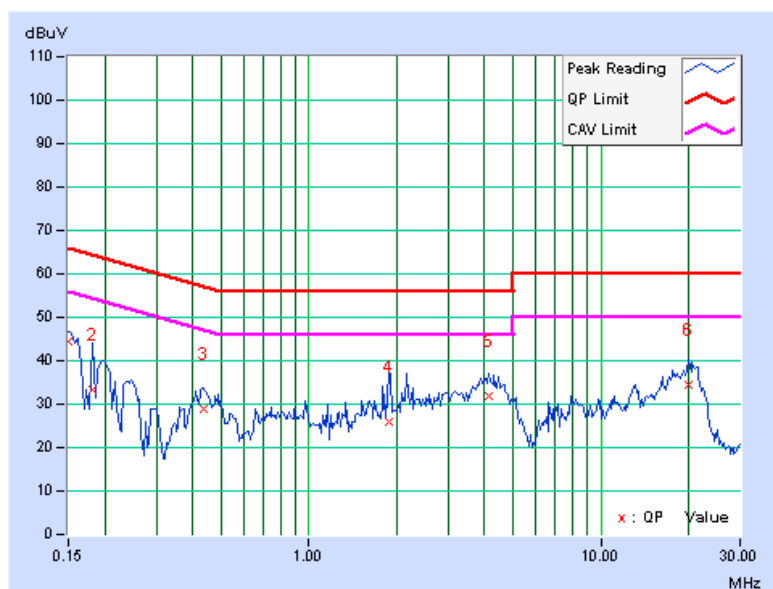

### 4.1.8 TEST RESULTS (MODE 2)

PHASE	Line (L)	6dB BANDWIDTH	9 kHz
-------	----------	---------------	-------

No	Freq. [MHz]	Corr. Factor (dB)	Reading Value [dB (uV)]		Emission Level [dB (uV)]		Limit [dB (uV)]		Margin (dB)	
			Q.P.	AV.	Q.P.	AV.	Q.P.	AV.	Q.P.	AV.
1	0.158	0.11	41.65	30.89	41.76	31.00	65.58	55.58	-23.82	-24.58
2	0.205	0.13	27.97	11.77	28.10	11.90	63.42	53.42	-35.32	-41.52
3	0.427	0.13	26.47	17.21	26.60	17.34	57.30	47.30	-30.70	-29.96
4	2.387	0.17	25.12	19.01	25.29	19.18	56.00	46.00	-30.71	-26.82
5	7.648	0.37	28.83	23.98	29.20	24.35	60.00	50.00	-30.80	-25.65
6	21.129	0.70	37.98	33.50	38.68	34.20	60.00	50.00	-21.32	-15.80

- REMARKS:**
1. Q.P. and AV. are abbreviations of quasi-peak and average individually.
  2. "-": The Quasi-peak reading value also meets average limit and measurement with the average detector is unnecessary.
  3. The emission levels of other frequencies were very low against the limit.
  4. Margin value = Emission level - Limit value
  5. Correction factor = Insertion loss + Cable loss
  6. Emission Level = Correction Factor + Reading Value.

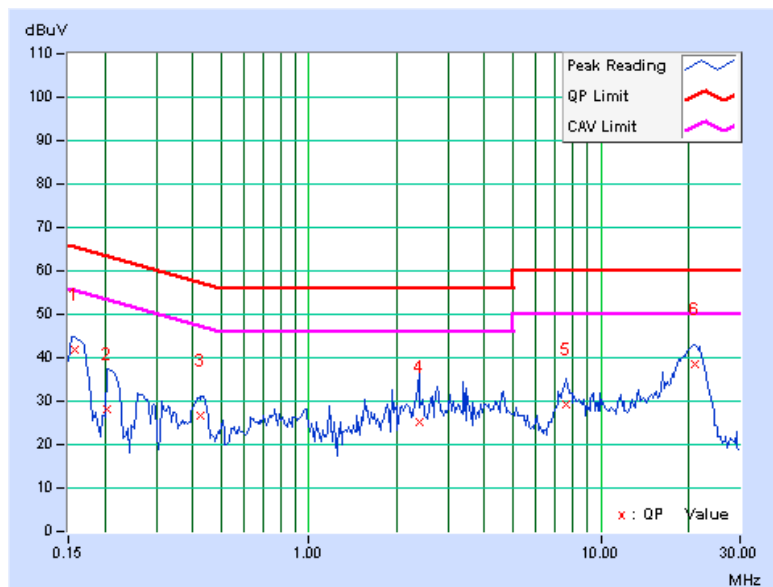

PHASE	Neutral (N)	6dB BANDWIDTH	9 kHz
-------	-------------	---------------	-------

No	Freq. [MHz]	Corr. Factor (dB)	Reading Value		Emission Level		Limit		Margin	
			[dB (uV)]		[dB (uV)]		[dB (uV)]		(dB)	
			Q.P.	AV.	Q.P.	AV.	Q.P.	AV.	Q.P.	AV.
1	0.159	0.12	39.75	31.42	39.87	31.54	65.53	55.53	-25.66	-23.99
2	0.209	0.14	32.04	21.07	32.18	21.21	63.26	53.26	-31.08	-32.05
3	0.392	0.15	26.14	13.31	26.29	13.46	58.02	48.02	-31.73	-34.56
4	2.293	0.20	26.51	19.21	26.71	19.41	56.00	46.00	-29.29	-26.59
5	7.559	0.61	30.15	24.87	30.76	25.48	60.00	50.00	-29.24	-24.52
6	20.867	1.49	37.96	33.23	39.45	34.72	60.00	50.00	-20.55	-15.28

- REMARKS:**
1. Q.P. and AV. are abbreviations of quasi-peak and average individually.
  2. "-": The Quasi-peak reading value also meets average limit and measurement with the average detector is unnecessary.
  3. The emission levels of other frequencies were very low against the limit.
  4. Margin value = Emission level - Limit value
  5. Correction factor = Insertion loss + Cable loss
  6. Emission Level = Correction Factor + Reading Value.

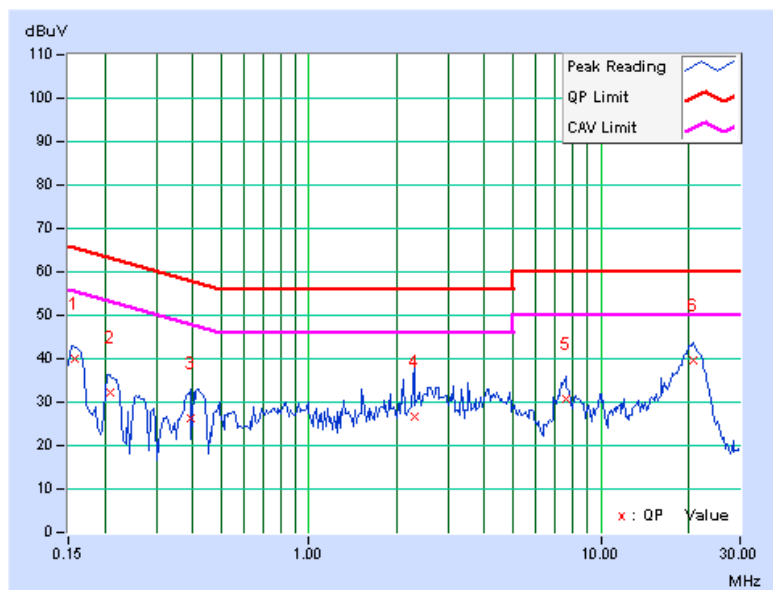

## 4.2 RADIATED EMISSION MEASUREMENT

### 4.2.1 LIMITS OF RADIATED EMISSION MEASUREMENT

Emissions radiated outside of the specified bands, shall be according to the general radiated limits in 15.209 as following:

Frequencies (MHz)	Field strength (microvolts/meter)	Measurement distance (meters)
0.009-0.490	2400/F(kHz)	300
0.490-1.705	24000/F(kHz)	30
1.705-30.0	30	30
30-88	100	3
88-216	150	3
216-960	200	3
Above 960	500	3

**NOTE:**

1. The lower limit shall apply at the transition frequencies.
2. Emission level (dBuV/m) = 20 log Emission level (uV/m).
3. As shown in 15.35(b), for frequencies above 1000MHz, the field strength limits are based on average detector, however, the peak field strength of any emission shall not exceed the maximum permitted average limits, specified above by more than 20dB under any condition of modulation.
4. Section 15.205 restricted bands of operation shall compliance with the limits in Section 15.209.





A D T

## 4.2.2 TEST INSTRUMENTS

### For Below 1GHz:

DESCRIPTION & MANUFACTURER	MODEL NO.	SERIAL NO.	CALIBRATED DATE	CALIBRATED UNTIL
Agilent Spectrum Analyzer	E4446A	MY48250254	July 14, 2010	July 13, 2011
Agilent Pre-Selector	N9039A	MY46520311	July 14, 2010	July 13, 2011
Agilent Signal Generator	N5181A	MY49060517	July 14, 2010	July 13, 2011
Mini-Circuits Pre-Amplifier	ZFL-1000VH2B	AMP-ZFL-03	Nov. 16, 2010	Nov. 15, 2011
Agilent Pre-Amplifier	8449B	3008A02578	July 05, 2010	July 04, 2011
Miteq Pre-Amplifier	AFS33-1800265 0-30-8P-44	881786	NA	NA
SCHWARZBECK Trilog Broadband Antenna	VULB 9168	9168-360	Apr. 29, 2010	Apr. 28, 2011
AISI Horn_Antenna	AIH.8018	000032009111 0	Nov. 12, 2010	Nov. 11, 2011
SCHWARZBECK Horn_Antenna	BBHA 9170	9170-424	Oct. 08, 2010	Oct. 07, 2011
RF CABLE	NA	RF104-201 RF104-203 RF104-204	Dec. 27, 2010	Dec. 26, 2011
RF Cable	NA	CHGCAB_001	NA	NA
Software	ADT_Radiated_ V8.7.05	NA	NA	NA
CT Antenna Tower & Turn Table	NA	NA	NA	NA

Note: 1. The calibration interval of the above test instruments is 12 months and the calibrations are traceable to NML/ROC and NIST/USA.

2. The horn antenna, preamplifier (model: 8449B) are used only for the measurement of emission frequency above 1GHz if tested.

3. The test was performed in 966 Chamber No. G.

4. The FCC Site Registration No. is 966073.

5. The VCCI Site Registration No. is G-137.

6. The CANADA Site Registration No. is IC 7450H-2.



A D T

**For Above 1GHz:**

DESCRIPTION & MANUFACTURER	MODEL NO.	SERIAL NO.	CALIBRATED DATE	CALIBRATED UNTIL
Agilent Spectrum Analyzer	E4446A	MY48250253	Aug. 23, 2010	Aug. 22, 2011
Agilent Pre-Selector	N9039A	MY46520310	Aug. 23, 2010	Aug. 22, 2011
Agilent Signal Generator	N5181A	MY49060347	July 30, 2010	July 29, 2011
LIG NEX1 Test Receiver	ER-265	L09068005	Oct. 25, 2010	Oct. 24, 2011
Mini-Circuits Pre-Amplifier	ZFL-1000VH2B	AMP-ZFL-04	Nov. 16, 2010	Nov. 15, 2011
Agilent Pre-Amplifier	8449B	3008A02465	Feb. 28, 2011	Feb. 27, 2012
Miteq Pre-Amplifier	AFS33-1800265 0-30-8P-44	881786	NA	NA
SCHWARZBECK Trilog Broadband Antenna	VULB 9168	9168-361	Apr. 28, 2010	Apr. 27, 2011
AISI Horn_Antenna	AIH.8018	000022009111 0	Nov. 22, 2010	Nov. 21, 2011
SCHWARZBECK Horn_Antenna	BBHA 9170	9170-424	Oct. 08, 2010	Oct. 07, 2011
RF CABLE	NA	RF104-205 RF104-207 RF104-202	Dec. 28, 2010	Dec. 27, 2011
RF Cable	NA	CHHCAB_001	NA	NA
Software	ADT_Radiated_V8.7.05	NA	NA	NA
CT Antenna Tower & Turn Table	NA	NA	NA	NA

- Note: 1. The calibration interval of the above test instruments is 12 months and the calibrations are traceable to NML/ROC and NIST/USA.  
 2. The horn antenna, preamplifier (model: 8449B) are used only for the measurement of emission frequency above 1GHz if tested.  
 3. The test was performed in 966 Chamber No. H.  
 4. The FCC Site Registration No. is 797305.  
 5. The CANADA Site Registration No. is IC 7450H-3.

### 4.2.3 TEST PROCEDURES

- a. The EUT was placed on the top of a rotating table 0.8 meters above the ground at 3 meters chamber room. The table was rotated 360 degrees to determine the position of the highest radiation.
- b. The EUT was set 3 meters away from the interference-receiving antenna, which was mounted on the top of a variable-height antenna tower.
- c. The height of antenna is varied from one meter to four meters above the ground to determine the maximum value of the field strength. Both horizontal and vertical polarizations of the antenna are set to make the measurement.
- d. For each suspected emission, the EUT was arranged to its worst case and then the antenna was tuned to heights from 1 meter to 4 meters and the rotatable table was turned from 0 degrees to 360 degrees to find the maximum reading.
- e. The test-receiver system was set to quasi-peak detect function and specified bandwidth with maximum hold mode when the test frequency is below 1 GHz.
- f. The test-receiver system was set to peak and average detect function and specified bandwidth with maximum hold mode when the test frequency is above 1 GHz. If the peak reading value also meets average limit, measurement with the average detector is unnecessary.

**NOTE:**

1. The resolution bandwidth and video bandwidth of test receiver/spectrum analyzer is 120kHz for Peak detection (PK) and Quasi-peak detection (QP) at frequency below 1GHz.
2. The resolution bandwidth of test receiver/spectrum analyzer is 1 MHz and video bandwidth is 3MHz for Peak detection at frequency above 1GHz.
3. The resolution bandwidth of test receiver/spectrum analyzer is 1MHz and the video bandwidth is 10Hz for Average detection (AV) at frequency above 1GHz.

### 4.2.4 DEVIATION FROM TEST STANDARD

No deviation

#### 4.2.5 TEST SETUP

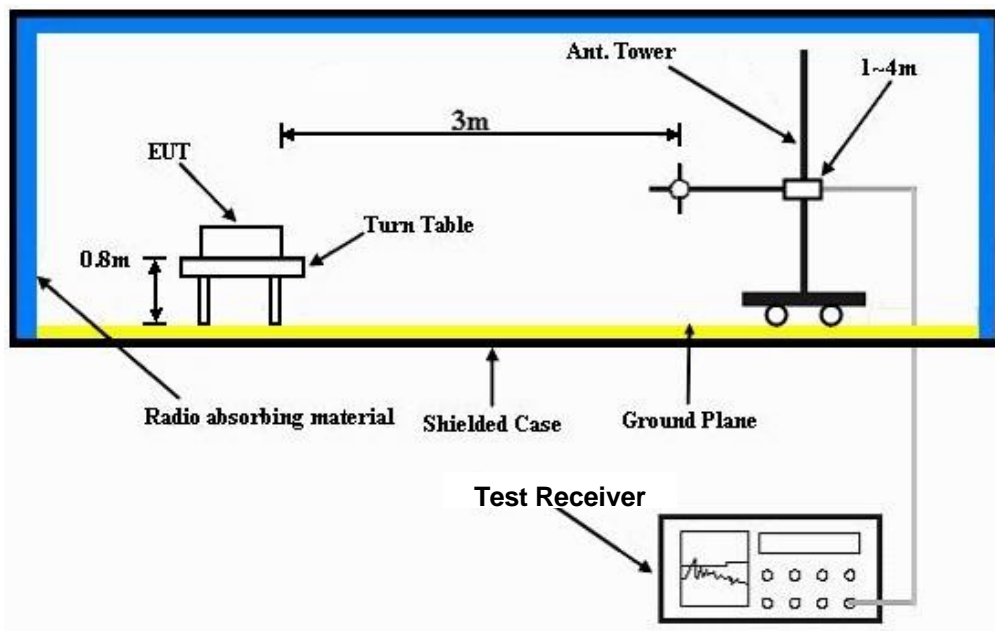

For the actual test configuration, please refer to the related item – Photographs of the Test Configuration.

#### 4.2.6 EUT OPERATING CONDITIONS

1. Turned on the power of all equipment.
2. Prepared other computer system support unit 1 (Notebook Computer) to act as communication partner and placed it outside of testing area.
3. The communication partner ran test program “RT3352QA.exe” to enable EUT under transmission/receiving condition continuously via one UTP cable.



A D T

### 4.2.7 TEST RESULTS

#### BELOW 1GHz WORST-CASE DATA : 802.11n (20MHz) OFDM MODULATION

EUT TEST CONDITION		MEASUREMENT DETAIL	
CHANNEL	Channel 6	FREQUENCY RANGE	Below 1000MHz
INPUT POWER	120V / 60Hz	DETECTOR FUNCTION	Quasi-Peak
ENVIRONMENTAL CONDITIONS	16deg. C, 67%RH 1023 hPa	TESTED BY	Frank Liu

ANTENNA POLARITY & TEST DISTANCE: HORIZONTAL AT 3 M								
NO.	FREQ. (MHz)	EMISSION LEVEL (dBuV/m)	LIMIT (dBuV/m)	MARGIN (dB)	ANTENNA HEIGHT (m)	TABLE ANGLE (Degree)	RAW VALUE (dBuV)	CORRECTION FACTOR (dB/m)
1	250.03	35.5 QP	46.0	-10.5	1.25 H	278	22.06	13.42
2	480.01	32.2 QP	46.0	-13.8	1.75 H	304	12.63	19.61
3	500.02	32.0 QP	46.0	-14.0	2.00 H	246	11.94	20.10
4	666.64	34.8 QP	46.0	-11.2	1.50 H	0	11.54	23.26
5	722.18	33.8 QP	46.0	-12.2	1.25 H	178	9.80	23.96
6	933.33	32.2 QP	46.0	-13.8	1.00 H	360	5.11	27.09
ANTENNA POLARITY & TEST DISTANCE: VERTICAL AT 3 M								
NO.	FREQ. (MHz)	EMISSION LEVEL (dBuV/m)	LIMIT (dBuV/m)	MARGIN (dB)	ANTENNA HEIGHT (m)	TABLE ANGLE (Degree)	RAW VALUE (dBuV)	CORRECTION FACTOR (dB/m)
1	43.80	34.1 QP	40.0	-5.9	1.23 V	65	19.82	14.30
2	106.74	35.6 QP	43.5	-7.9	1.29 V	311	25.09	10.54
3	250.03	27.4 QP	46.0	-18.6	1.62 V	324	14.00	13.42
4	480.01	34.6 QP	46.0	-11.4	1.00 V	287	15.01	19.61
5	719.34	34.3 QP	46.0	-11.7	1.32 V	211	10.37	23.92
6	959.97	35.5 QP	46.0	-10.5	1.00 V	273	8.18	27.31

- REMARKS:**
1. Emission level (dBuV/m) = Raw Value (dBuV) + Correction Factor (dB/m).
  2. Correction Factor (dB/m) = Antenna Factor (dB/m) + Cable Factor (dB).
  3. The other emission levels were very low against the limit.
  4. Margin value = Emission level – Limit value.



## ABOVE 1GHz WORST-CASE DATA

### 802.11b DSSS MODULATION

EUT TEST CONDITION		MEASUREMENT DETAIL	
CHANNEL	Channel 1	FREQUENCY RANGE	1 ~ 25GHz
INPUT POWER	120V / 60Hz	DETECTOR FUNCTION	Peak (PK) Average (AV)
ENVIRONMENTAL CONDITIONS	21deg. C, 66%RH 1023 hPa	TESTED BY	Frank Liu

ANTENNA POLARITY & TEST DISTANCE: HORIZONTAL AT 3 M								
NO.	FREQ. (MHz)	EMISSION LEVEL (dBuV/m)	LIMIT (dBuV/m)	MARGIN (dB)	ANTENNA HEIGHT (m)	TABLE ANGLE (Degree)	RAW VALUE (dBuV)	CORRECTION FACTOR (dB/m)
1	2390.00	55.6 PK	74.0	-18.4	1.36 H	72	26.92	28.68
2	2390.00	43.7 AV	54.0	-10.3	1.36 H	72	15.02	28.68
3	*2412.00	101.2 PK			1.37 H	69	72.50	28.70
4	*2412.00	98.6 AV			1.37 H	69	69.90	28.70
5	4824.00	50.9 PK	74.0	-23.1	1.00 H	112	20.39	30.51
6	4824.00	47.3 AV	54.0	-6.7	1.00 H	112	16.79	30.51
ANTENNA POLARITY & TEST DISTANCE: VERTICAL AT 3 M								
NO.	FREQ. (MHz)	EMISSION LEVEL (dBuV/m)	LIMIT (dBuV/m)	MARGIN (dB)	ANTENNA HEIGHT (m)	TABLE ANGLE (Degree)	RAW VALUE (dBuV)	CORRECTION FACTOR (dB/m)
1	2390.00	59.5 PK	74.0	-14.5	1.00 V	87	28.29	31.21
2	2390.00	48.9 AV	54.0	-5.1	1.00 V	87	17.69	31.21
3	*2412.00	109.2 PK			1.01 V	100	77.93	31.27
4	*2412.00	106.4 AV			1.01 V	100	75.13	31.27
5	4824.00	56.2 PK	74.0	-17.8	1.04 V	219	16.78	39.42
6	4824.00	53.2 AV	54.0	-0.8	1.04 V	219	13.78	39.42

- REMARKS:**
1. Emission level (dBuV/m) = Raw Value (dBuV) + Correction Factor (dB/m).
  2. Correction Factor (dB/m) = Antenna Factor (dB/m) + Cable Factor (dB).
  3. The other emission levels were very low against the limit.
  4. Margin value = Emission level – Limit value.
  5. “ \* ”: Fundamental frequency.



A D T

EUT TEST CONDITION		MEASUREMENT DETAIL	
CHANNEL	Channel 6	FREQUENCY RANGE	1 ~ 25GHz
INPUT POWER	120V / 60Hz	DETECTOR FUNCTION	Peak (PK) Average (AV)
ENVIRONMENTAL CONDITIONS	21deg. C, 66%RH 1023 hPa	TESTED BY	Frank Liu

ANTENNA POLARITY & TEST DISTANCE: HORIZONTAL AT 3 M								
NO.	FREQ. (MHz)	EMISSION LEVEL (dBuV/m)	LIMIT (dBuV/m)	MARGIN (dB)	ANTENNA HEIGHT (m)	TABLE ANGLE (Degree)	RAW VALUE (dBuV)	CORRECTION FACTOR (dB/m)
1	*2437.00	101.1 PK			1.29 H	63	72.37	28.73
2	*2437.00	98.9 AV			1.29 H	63	70.17	28.73
3	4874.00	51.2 PK	74.0	-22.8	1.00 H	124	20.66	30.54
4	4874.00	47.4 AV	54.0	-6.6	1.00 H	124	16.86	30.54
5	7311.00	54.6 PK	74.0	-19.4	1.12 H	243	22.59	32.01
6	7311.00	42.3 AV	54.0	-11.7	1.12 H	243	10.29	32.01
ANTENNA POLARITY & TEST DISTANCE: VERTICAL AT 3 M								
NO.	FREQ. (MHz)	EMISSION LEVEL (dBuV/m)	LIMIT (dBuV/m)	MARGIN (dB)	ANTENNA HEIGHT (m)	TABLE ANGLE (Degree)	RAW VALUE (dBuV)	CORRECTION FACTOR (dB/m)
1	*2437.00	108.4 PK			1.00 V	76	77.06	31.34
2	*2437.00	105.2 AV			1.00 V	76	73.86	31.34
3	4874.00	56.7 PK	74.0	-17.3	1.14 V	213	17.08	39.62
4	<b>4874.00</b>	<b>53.4 AV</b>	<b>54.0</b>	<b>-0.6</b>	<b>1.14 V</b>	<b>213</b>	<b>13.78</b>	<b>39.62</b>
5	7311.00	54.7 PK	74.0	-19.3	1.02 V	112	10.60	44.10
6	7311.00	42.4 AV	54.0	-11.6	1.02 V	112	-1.70	44.10

- REMARKS:**
1. Emission level (dBuV/m) = Raw Value (dBuV) + Correction Factor (dB/m).
  2. Correction Factor (dB/m) = Antenna Factor (dB/m) + Cable Factor (dB).
  3. The other emission levels were very low against the limit.
  4. Margin value = Emission level – Limit value.
  5. “ \* “: Fundamental frequency.



A D T

EUT TEST CONDITION		MEASUREMENT DETAIL	
CHANNEL	Channel 11	FREQUENCY RANGE	1 ~ 25GHz
INPUT POWER	120V / 60Hz	DETECTOR FUNCTION	Peak (PK) Average (AV)
ENVIRONMENTAL CONDITIONS	21deg. C, 66%RH 1023 hPa	TESTED BY	Frank Liu

**ANTENNA POLARITY & TEST DISTANCE: HORIZONTAL AT 3 M**

NO.	FREQ. (MHz)	EMISSION LEVEL (dBuV/m)	LIMIT (dBuV/m)	MARGIN (dB)	ANTENNA HEIGHT (m)	TABLE ANGLE (Degree)	RAW VALUE (dBuV)	CORRECTION FACTOR (dB/m)
1	*2462.00	100.4 PK			1.34 H	50	71.65	28.75
2	*2462.00	97.3 AV			1.34 H	50	68.55	28.75
3	2483.50	55.8 PK	74.0	-18.2	1.34 H	53	27.03	28.77
4	2483.50	44.3 AV	54.0	-9.7	1.34 H	53	15.53	28.77
5	4924.00	51.7 PK	74.0	-22.3	1.00 H	129	21.13	30.57
6	4924.00	47.9 AV	54.0	-6.1	1.00 H	129	17.33	30.57
7	7386.00	54.9 PK	74.0	-19.1	1.14 H	257	22.86	32.04
8	7386.00	42.7 AV	54.0	-11.3	1.14 H	257	10.66	32.04

**ANTENNA POLARITY & TEST DISTANCE: VERTICAL AT 3 M**

NO.	FREQ. (MHz)	EMISSION LEVEL (dBuV/m)	LIMIT (dBuV/m)	MARGIN (dB)	ANTENNA HEIGHT (m)	TABLE ANGLE (Degree)	RAW VALUE (dBuV)	CORRECTION FACTOR (dB/m)
1	*2462.00	107.2 PK			1.00 V	87	75.80	31.40
2	*2462.00	104.6 AV			1.00 V	87	73.20	31.40
3	2487.50	59.0 PK	74.0	-15.0	1.00 V	262	27.53	31.47
4	2487.50	47.7 AV	54.0	-6.3	1.00 V	262	16.23	31.47
5	4924.00	56.4 PK	74.0	-17.6	1.13 V	210	16.58	39.82
6	4924.00	53.2 AV	54.0	-0.8	1.13 V	210	13.38	39.82
7	7386.00	52.0 PK	74.0	-22.0	1.60 V	186	7.82	44.18
8	7386.00	41.9 AV	54.0	-12.1	1.60 V	186	-2.28	44.18

- REMARKS:**
1. Emission level (dBuV/m) = Raw Value (dBuV) + Correction Factor (dB/m).
  2. Correction Factor (dB/m) = Antenna Factor (dB/m) + Cable Factor (dB).
  3. The other emission levels were very low against the limit.
  4. Margin value = Emission level – Limit value.
  5. “ \* “: Fundamental frequency.





A D T

RESTRICTED BANDEDGE (802.11b MODE, CH1, HORIZONTAL)

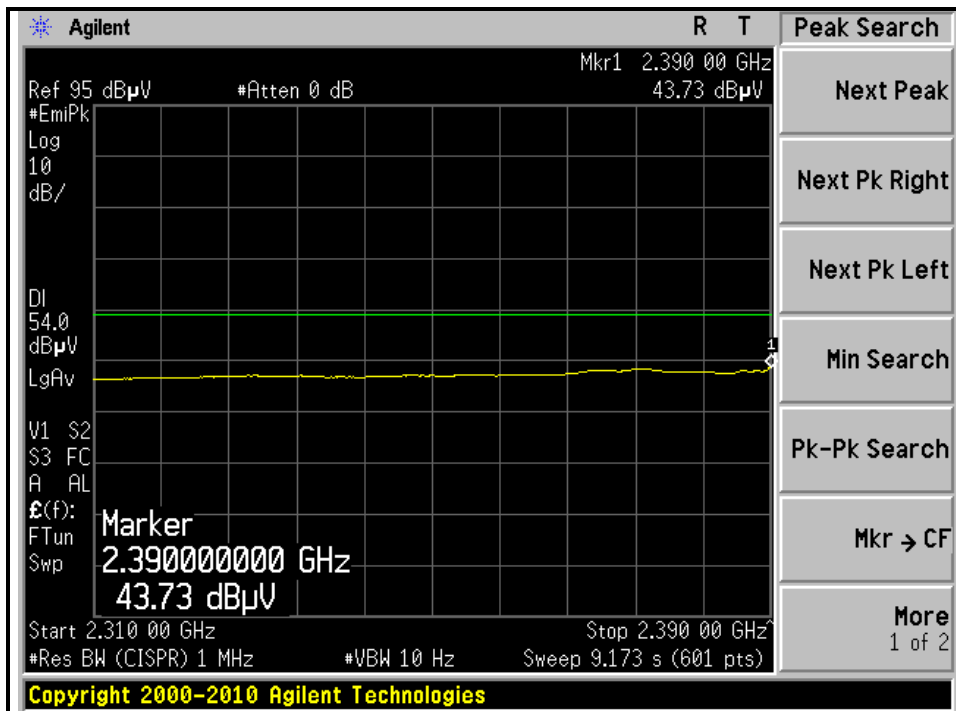
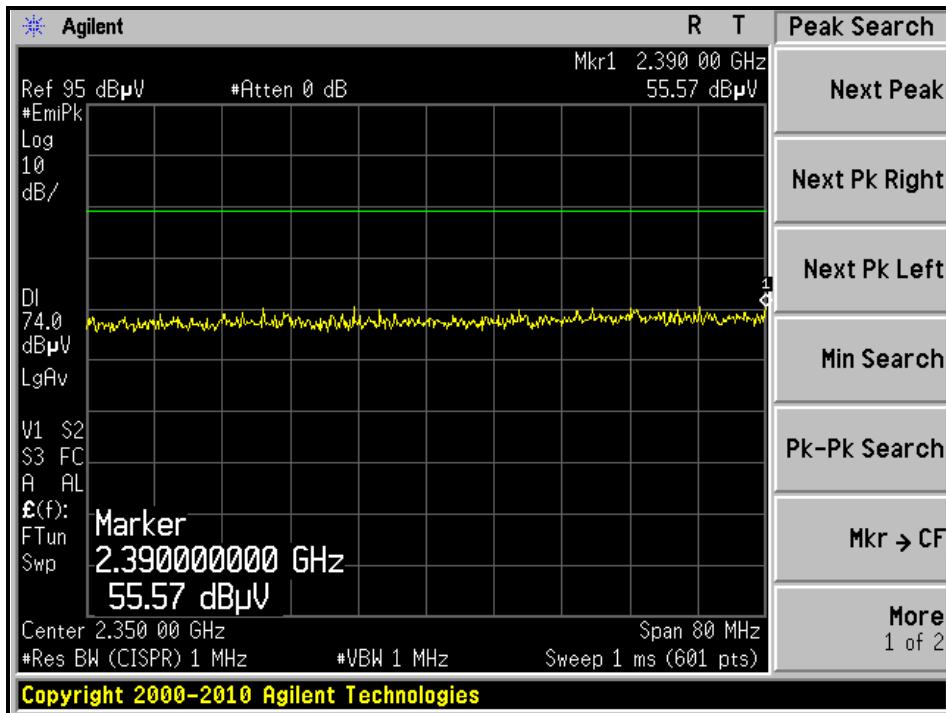



A D T

RESTRICTED BANDEDGE (802.11b MODE, CH1, VERTICAL )

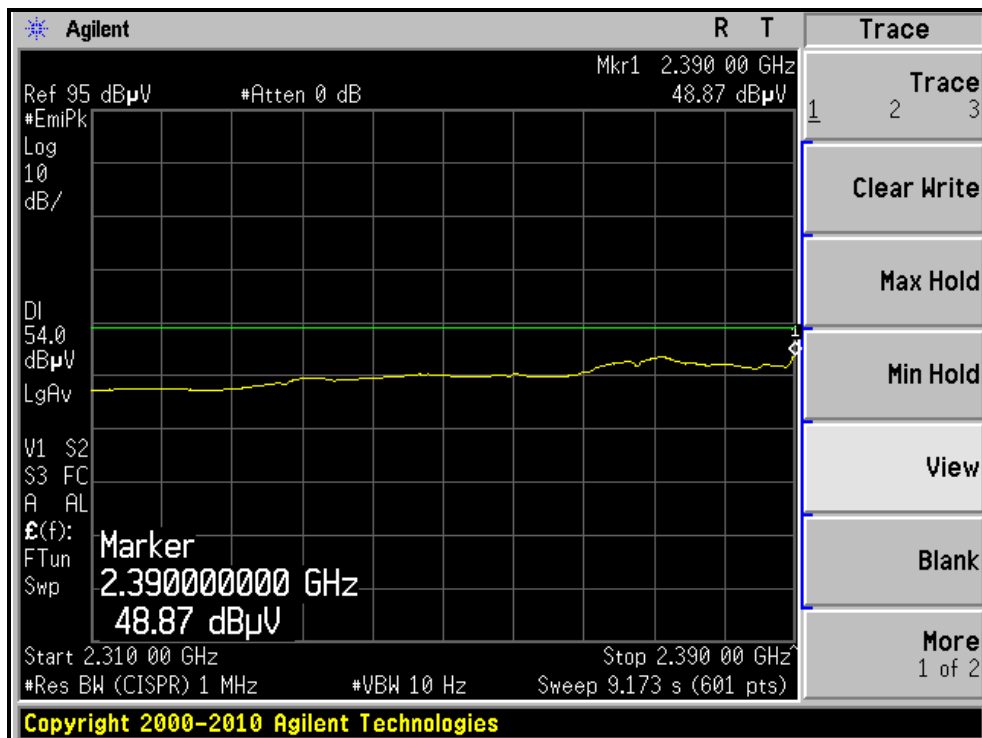
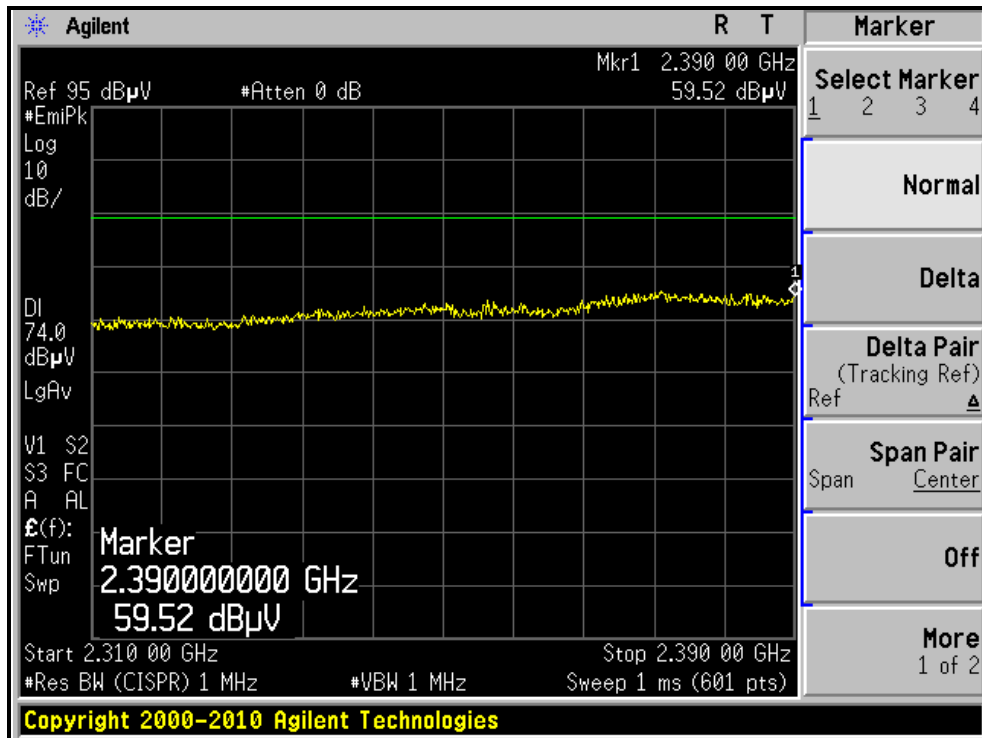



A D T

RESTRICTED BANDEDGE (802.11b MODE, CH11, HORIZONTAL )

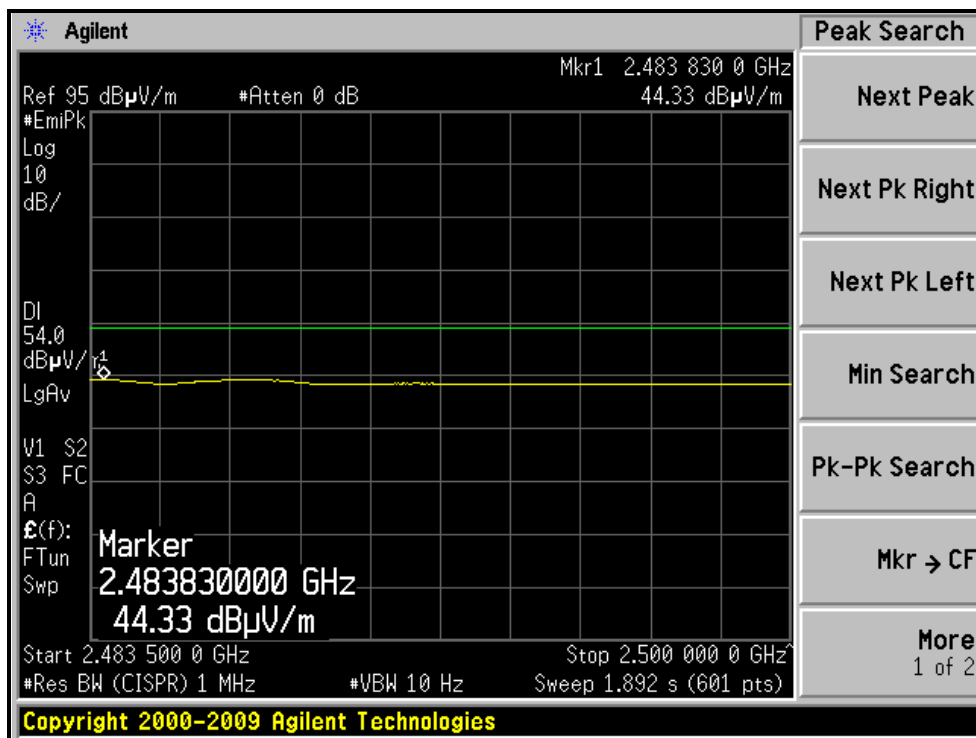
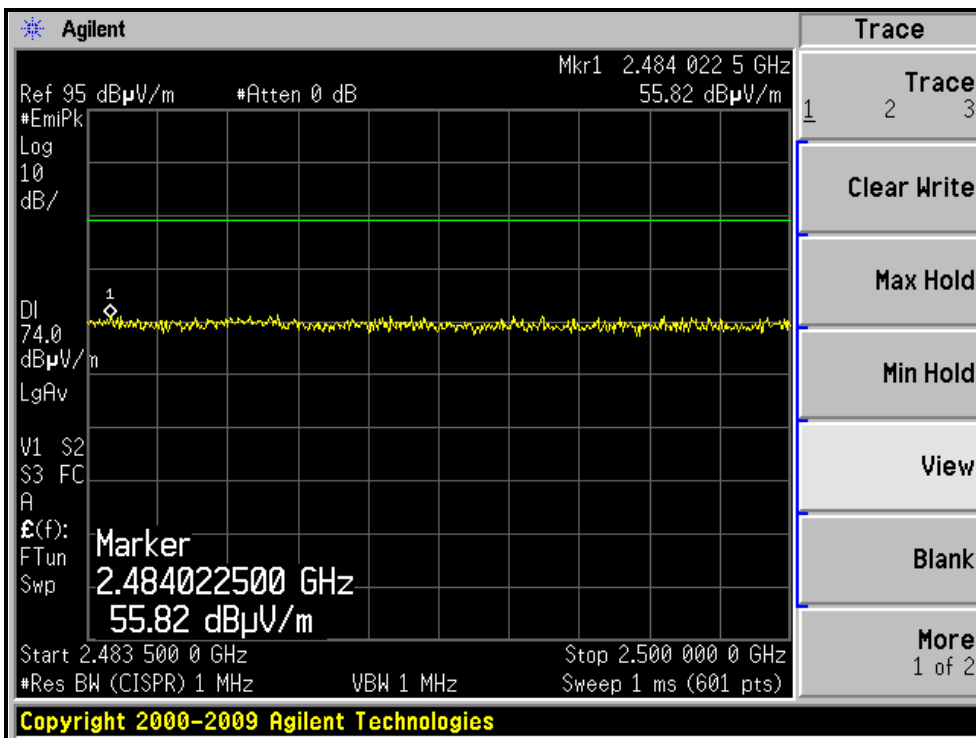



A D T

RESTRICTED BANDEDGE (802.11b MODE, CH11, VERTICAL)

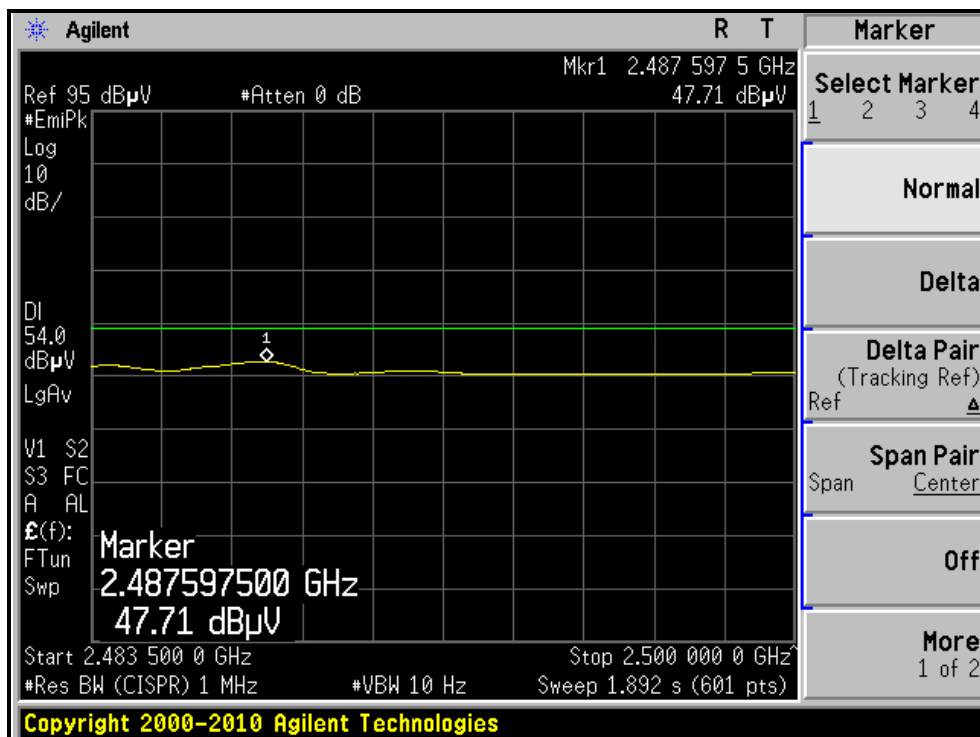
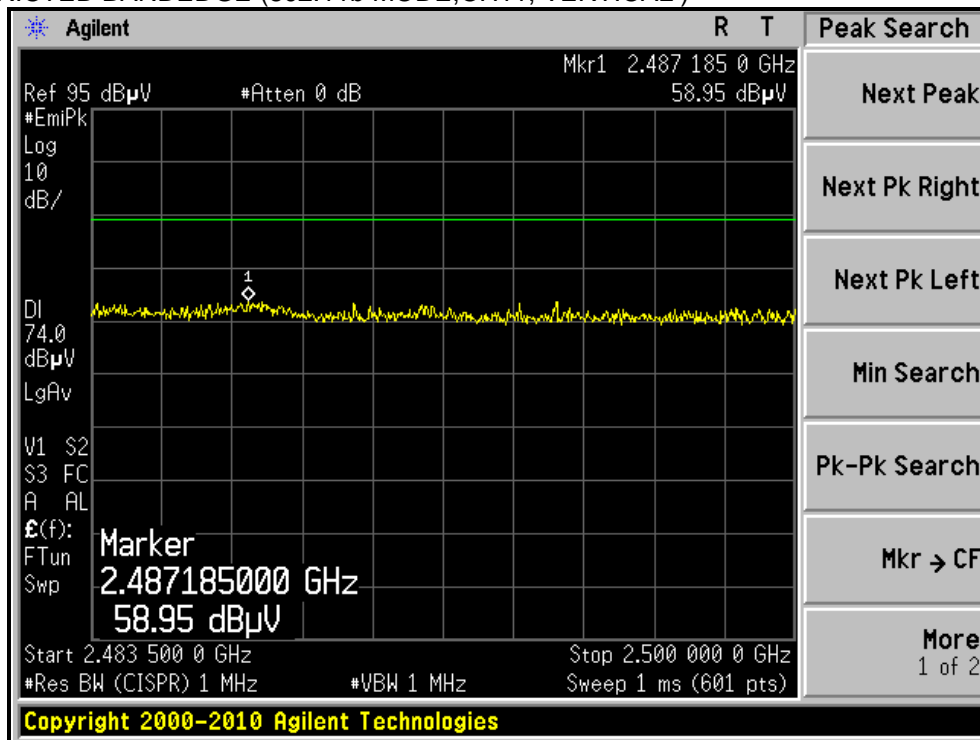



A D T

**802.11g OFDM MODULATION**

EUT TEST CONDITION		MEASUREMENT DETAIL	
CHANNEL	Channel 1	FREQUENCY RANGE	1 ~ 25GHz
INPUT POWER	120V / 60Hz	DETECTOR FUNCTION	Peak (PK) Average (AV)
ENVIRONMENTAL CONDITIONS	21deg. C, 66%RH 1023 hPa	TESTED BY	Frank Liu

ANTENNA POLARITY & TEST DISTANCE: HORIZONTAL AT 3 M								
NO.	FREQ. (MHz)	EMISSION LEVEL (dBuV/m)	LIMIT (dBuV/m)	MARGIN (dB)	ANTENNA HEIGHT (m)	TABLE ANGLE (Degree)	RAW VALUE (dBuV)	CORRECTION FACTOR (dB/m)
1	2390.00	62.0 PK	74.0	-12.0	1.00 H	147	33.32	28.68
2	2390.00	47.9 AV	54.0	-6.1	1.00 H	147	19.22	28.68
3	*2412.00	100.1 PK			1.00 H	154	71.40	28.70
4	*2412.00	92.4 AV			1.00 H	154	63.70	28.70
5	4824.00	53.3 PK	74.0	-20.7	1.00 H	111	22.79	30.51
6	4824.00	40.9 AV	54.0	-13.1	1.00 H	111	10.39	30.51
ANTENNA POLARITY & TEST DISTANCE: VERTICAL AT 3 M								
NO.	FREQ. (MHz)	EMISSION LEVEL (dBuV/m)	LIMIT (dBuV/m)	MARGIN (dB)	ANTENNA HEIGHT (m)	TABLE ANGLE (Degree)	RAW VALUE (dBuV)	CORRECTION FACTOR (dB/m)
1	2389.60	69.6 PK	74.0	-4.4	1.34 V	327	38.39	31.21
2	2389.60	52.8 AV	54.0	-1.2	1.34 V	327	21.09	31.21
3	*2412.00	109.9 PK			1.04 V	325	78.63	31.27
4	*2412.00	100.8 AV			1.04 V	325	69.53	31.27
5	4824.00	55.7 PK	74.0	-18.3	1.01 V	62	16.28	39.42
6	4824.00	45.0 AV	54.0	-9.0	1.01 V	62	5.58	39.42

- REMARKS:**
1. Emission level (dBuV/m) = Raw Value (dBuV) + Correction Factor (dB/m).
  2. Correction Factor (dB/m) = Antenna Factor (dB/m) + Cable Factor (dB).
  3. The other emission levels were very low against the limit.
  4. Margin value = Emission level – Limit value.
  5. “ \* “: Fundamental frequency.



A D T

EUT TEST CONDITION		MEASUREMENT DETAIL	
CHANNEL	Channel 6	FREQUENCY RANGE	1 ~ 25GHz
INPUT POWER	120V / 60Hz	DETECTOR FUNCTION	Peak (PK) Average (AV)
ENVIRONMENTAL CONDITIONS	21deg. C, 66%RH 1023 hPa	TESTED BY	Frank Liu

ANTENNA POLARITY & TEST DISTANCE: HORIZONTAL AT 3 M								
NO.	FREQ. (MHz)	EMISSION LEVEL (dBuV/m)	LIMIT (dBuV/m)	MARGIN (dB)	ANTENNA HEIGHT (m)	TABLE ANGLE (Degree)	RAW VALUE (dBuV)	CORRECTION FACTOR (dB/m)
1	*2437.00	99.7 PK			1.00 H	159	70.97	28.73
2	*2437.00	90.4 AV			1.00 H	159	61.67	28.73
3	4874.00	54.2 PK	74.0	-19.8	1.00 H	124	23.66	30.54
4	4874.00	42.8 AV	54.0	-11.2	1.00 H	124	12.26	30.54
5	7311.00	54.4 PK	74.0	-19.6	1.13 H	242	22.39	32.01
6	7311.00	42.1 AV	54.0	-11.9	1.13 H	242	10.09	32.01
ANTENNA POLARITY & TEST DISTANCE: VERTICAL AT 3 M								
NO.	FREQ. (MHz)	EMISSION LEVEL (dBuV/m)	LIMIT (dBuV/m)	MARGIN (dB)	ANTENNA HEIGHT (m)	TABLE ANGLE (Degree)	RAW VALUE (dBuV)	CORRECTION FACTOR (dB/m)
1	*2437.00	108.2 PK			1.03 V	324	76.86	31.34
2	*2437.00	98.4 AV			1.03 V	324	67.06	31.34
3	4874.00	58.4 PK	74.0	-15.6	1.01 V	64	18.78	39.62
4	4874.00	47.4 AV	54.0	-6.6	1.01 V	64	7.78	39.62
5	7311.00	52.6 PK	74.0	-21.4	1.51 V	154	8.50	44.10
6	7311.00	42.4 AV	54.0	-11.6	1.51 V	154	-1.70	44.10

- REMARKS:**
1. Emission level (dBuV/m) = Raw Value (dBuV) + Correction Factor (dB/m).
  2. Correction Factor (dB/m) = Antenna Factor (dB/m) + Cable Factor (dB).
  3. The other emission levels were very low against the limit.
  4. Margin value = Emission level – Limit value.
  5. “ \* “: Fundamental frequency.



A D T

EUT TEST CONDITION		MEASUREMENT DETAIL	
CHANNEL	Channel 11	FREQUENCY RANGE	1 ~ 25GHz
INPUT POWER	120V / 60Hz	DETECTOR FUNCTION	Peak (PK) Average (AV)
ENVIRONMENTAL CONDITIONS	21deg. C, 66%RH 1023 hPa	TESTED BY	Frank Liu

**ANTENNA POLARITY & TEST DISTANCE: HORIZONTAL AT 3 M**

NO.	FREQ. (MHz)	EMISSION LEVEL (dBuV/m)	LIMIT (dBuV/m)	MARGIN (dB)	ANTENNA HEIGHT (m)	TABLE ANGLE (Degree)	RAW VALUE (dBuV)	CORRECTION FACTOR (dB/m)
1	*2462.00	98.2 PK			1.04 H	163	69.45	28.75
2	*2462.00	87.4 AV			1.04 H	163	58.65	28.75
3	2483.50	64.8 PK	74.0	-9.2	1.03 H	154	36.03	28.77
4	2483.50	49.2 AV	54.0	-4.8	1.03 H	154	20.43	28.77
5	4924.00	54.0 PK	74.0	-20.0	1.00 H	109	23.43	30.57
6	4924.00	42.1 AV	54.0	-11.9	1.00 H	109	11.53	30.57
7	7386.00	54.8 PK	74.0	-19.2	1.12 H	249	22.76	32.04
8	7386.00	42.6 AV	54.0	-11.4	1.12 H	249	10.56	32.04

**ANTENNA POLARITY & TEST DISTANCE: VERTICAL AT 3 M**

NO.	FREQ. (MHz)	EMISSION LEVEL (dBuV/m)	LIMIT (dBuV/m)	MARGIN (dB)	ANTENNA HEIGHT (m)	TABLE ANGLE (Degree)	RAW VALUE (dBuV)	CORRECTION FACTOR (dB/m)
1	*2462.00	105.7 PK			1.15 V	327	74.30	31.40
2	*2462.00	95.7 AV			1.15 V	327	64.30	31.40
3	2483.50	69.8 PK	74.0	-4.2	1.01 V	338	38.34	31.46
4	2483.50	53.1 AV	54.0	-0.9	1.01 V	338	21.64	31.46
5	4924.00	58.2 PK	74.0	-15.8	1.04 V	74	18.38	39.82
6	4924.00	47.1 AV	54.0	-6.9	1.04 V	74	7.28	39.82
7	7386.00	52.4 PK	74.0	-21.6	1.57 V	164	8.22	44.18
8	7386.00	42.1 AV	54.0	-11.9	1.57 V	164	-2.08	44.18

- REMARKS:**
1. Emission level (dBuV/m) = Raw Value (dBuV) + Correction Factor (dB/m).
  2. Correction Factor (dB/m) = Antenna Factor (dB/m) + Cable Factor (dB).
  3. The other emission levels were very low against the limit.
  4. Margin value = Emission level – Limit value.
  5. “ \* “: Fundamental frequency.



A D T

RESTRICTED BANDEDGE (802.11g MODE, CH1, HORIZONTAL )

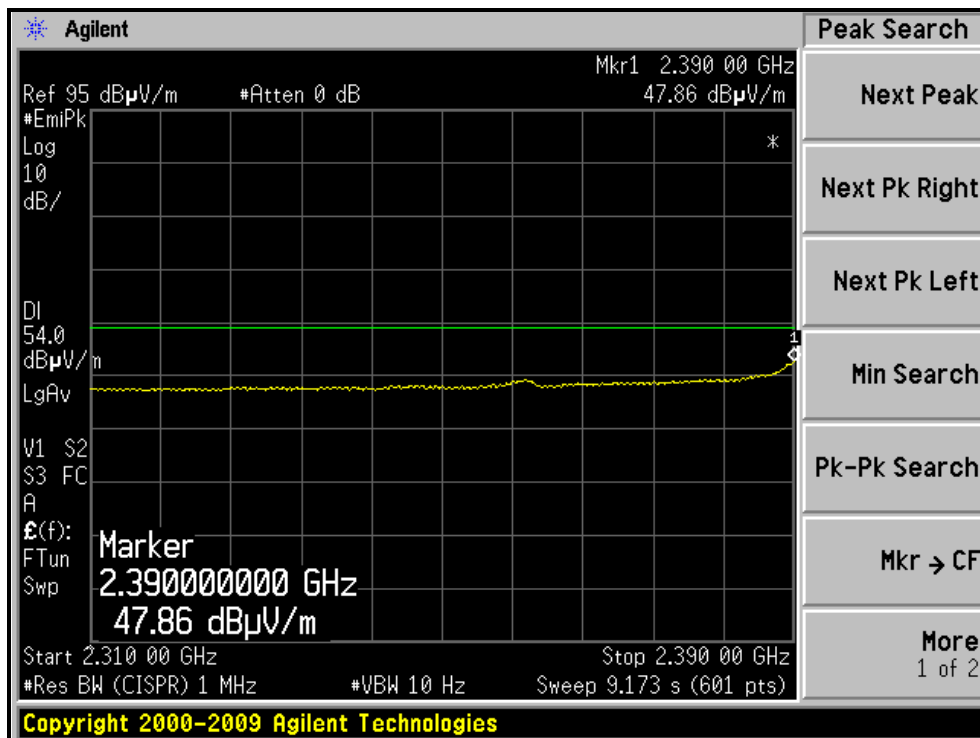
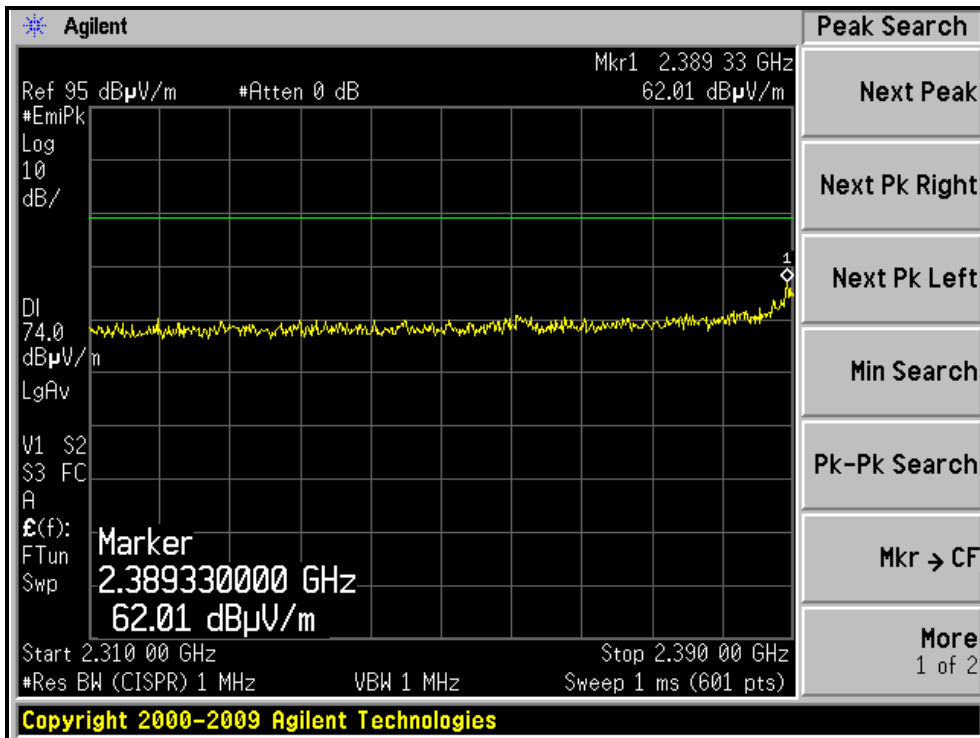





A D T

RESTRICTED BANDEDGE (802.11g MODE, CH1, VERTICAL )

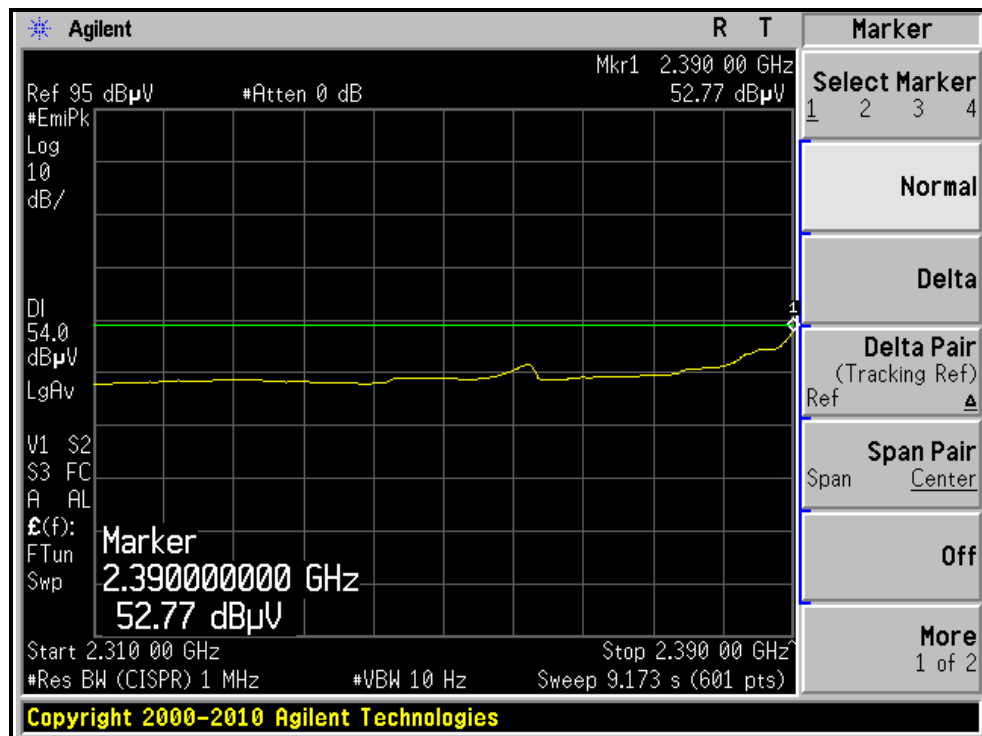
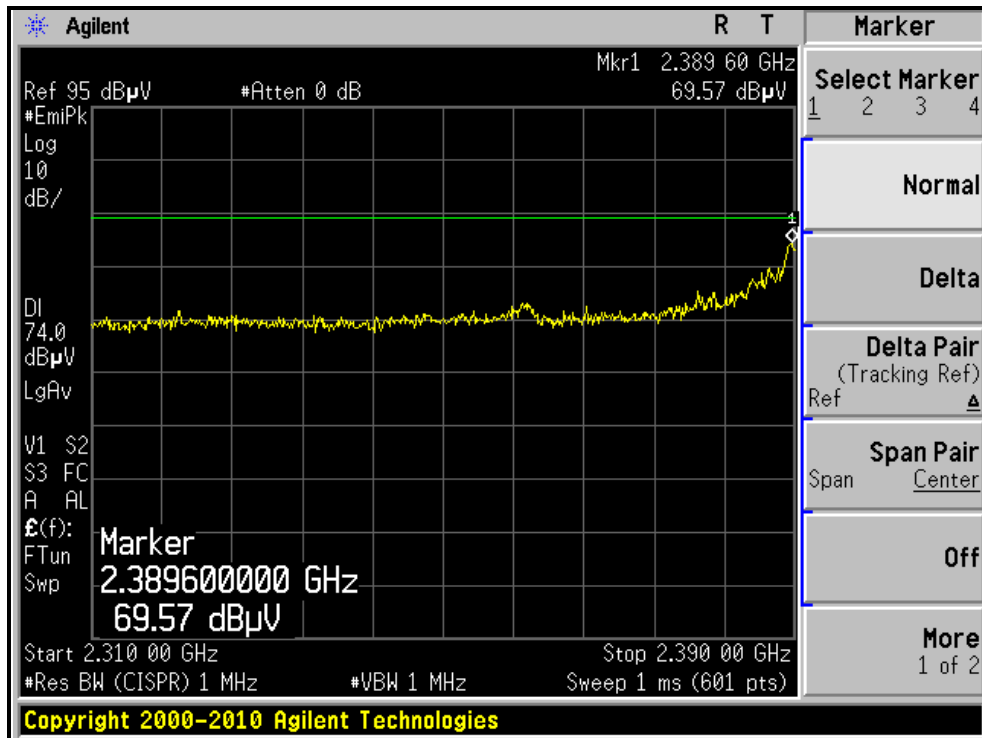



A D T

RESTRICTED BANDEDGE (802.11g MODE, CH11, HORIZONTAL )

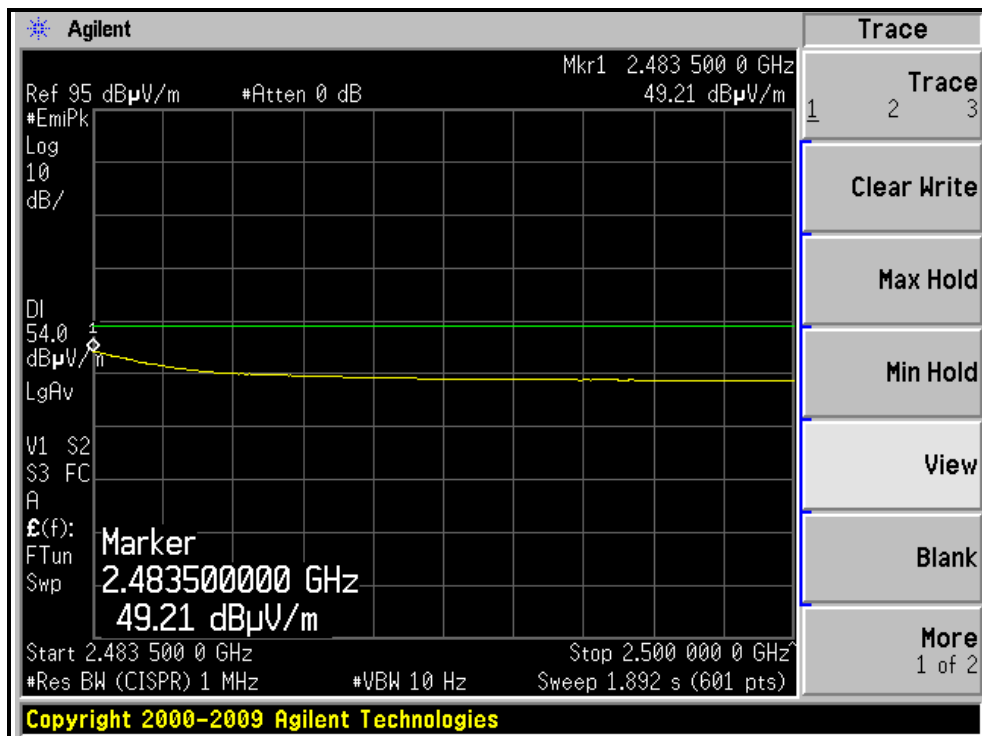
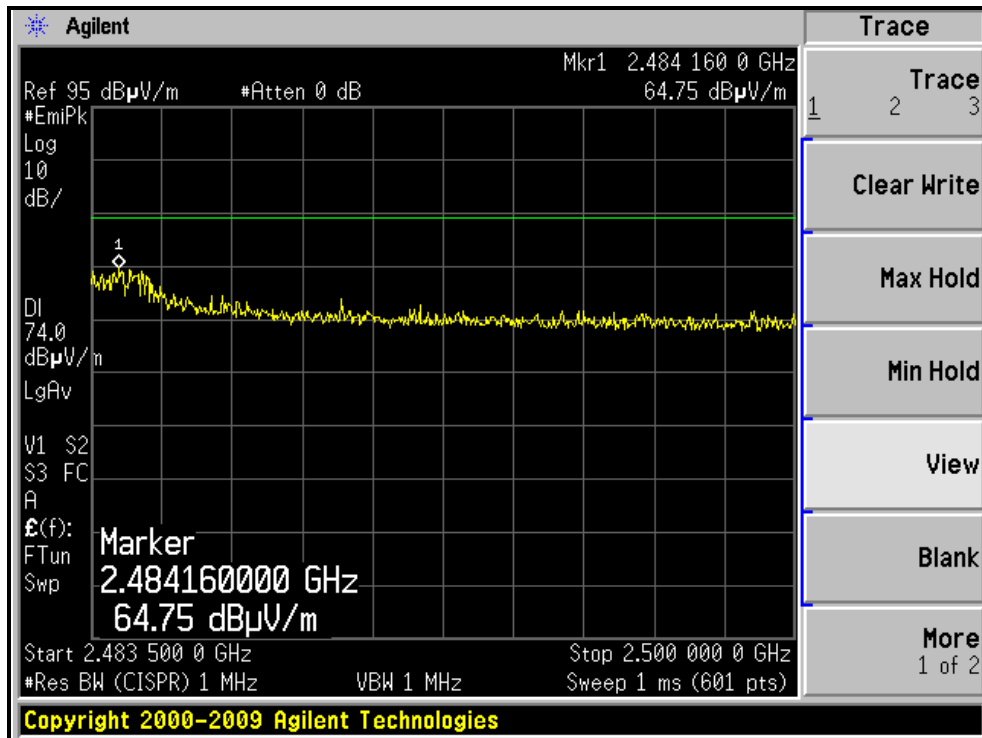



A D T

RESTRICTED BANDEDGE (802.11g MODE, CH11, VERTICAL )

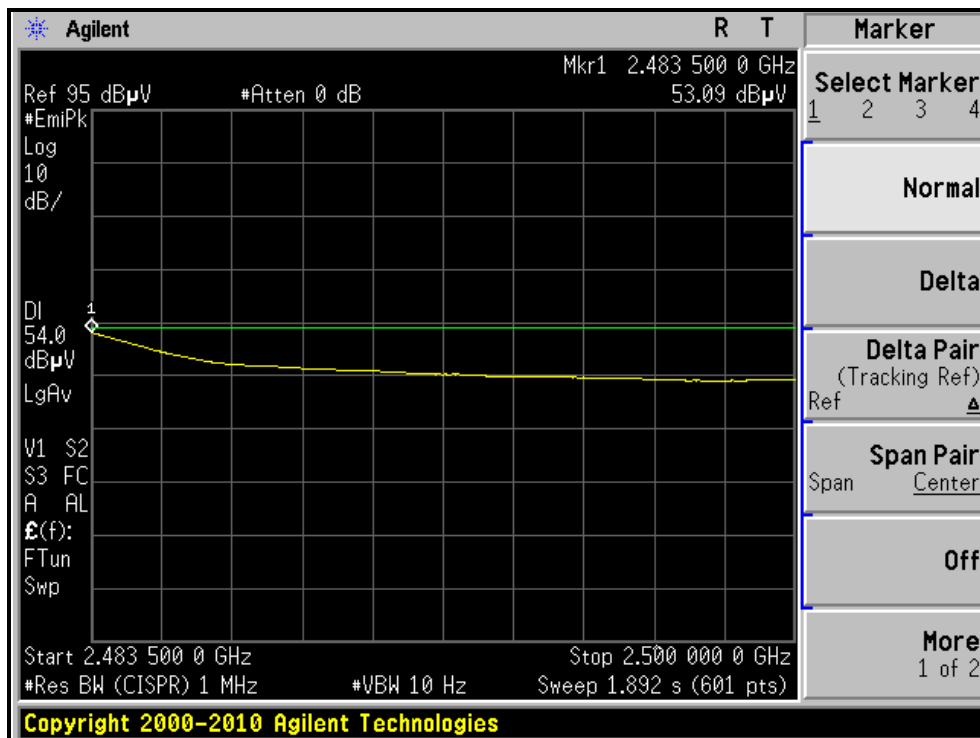
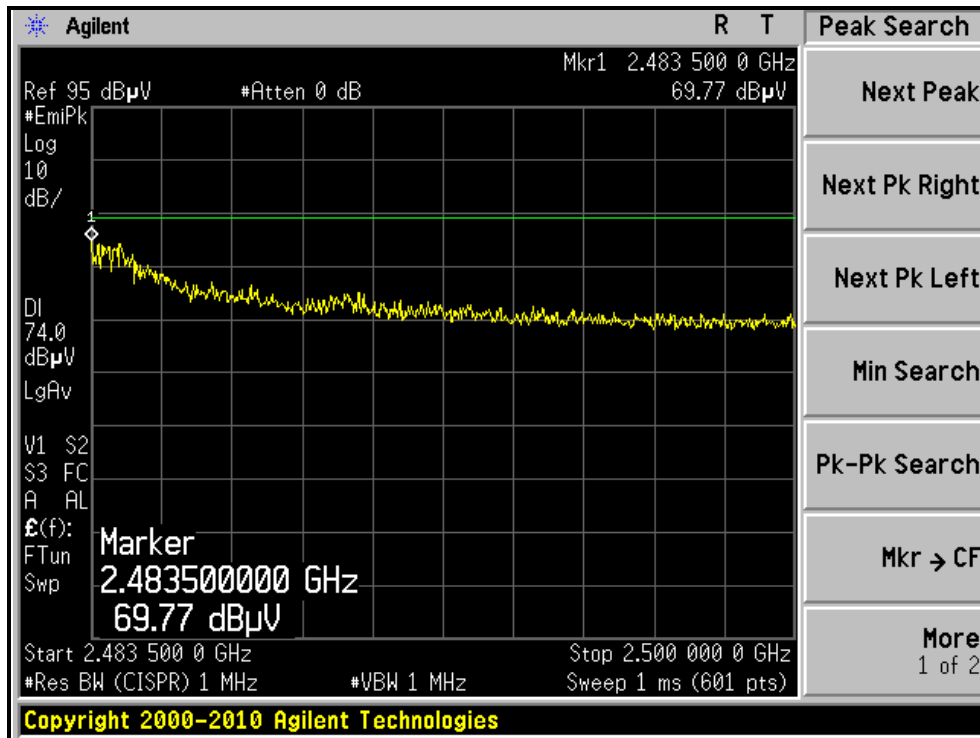



A D T

## 802.11n (20MHz) OFDM MODULATION

EUT TEST CONDITION		MEASUREMENT DETAIL	
CHANNEL	Channel 1	FREQUENCY RANGE	1 ~ 25GHz
INPUT POWER	120V / 60Hz	DETECTOR FUNCTION	Peak (PK) Average (AV)
ENVIRONMENTAL CONDITIONS	21deg. C, 66%RH 1023 hPa	TESTED BY	Frank Liu

ANTENNA POLARITY & TEST DISTANCE: HORIZONTAL AT 3 M								
NO.	FREQ. (MHz)	EMISSION LEVEL (dBuV/m)	LIMIT (dBuV/m)	MARGIN (dB)	ANTENNA HEIGHT (m)	TABLE ANGLE (Degree)	RAW VALUE (dBuV)	CORRECTION FACTOR (dB/m)
1	2390.00	55.4 PK	74.0	-18.6	1.23 H	159	26.72	28.68
2	2390.00	47.2 AV	54.0	-6.8	1.23 H	159	18.32	28.68
3	*2412.00	102.3 PK			1.24 H	141	73.60	28.70
4	*2412.00	90.3 AV			1.24 H	141	61.58	28.70
5	4824.00	54.8 PK	74.0	-19.2	1.00 H	147	24.29	30.51
6	4824.00	42.3 AV	54.0	-11.7	1.00 H	147	11.79	30.51
ANTENNA POLARITY & TEST DISTANCE: VERTICAL AT 3 M								
NO.	FREQ. (MHz)	EMISSION LEVEL (dBuV/m)	LIMIT (dBuV/m)	MARGIN (dB)	ANTENNA HEIGHT (m)	TABLE ANGLE (Degree)	RAW VALUE (dBuV)	CORRECTION FACTOR (dB/m)
1	2390.00	68.9 PK	74.0	-5.1	1.00 V	100	37.69	31.21
2	2390.00	52.2 AV	54.0	-1.8	1.00 V	100	20.99	31.21
3	*2412.00	111.8 PK			1.00 V	282	80.53	31.27
4	*2412.00	99.5 AV			1.00 V	282	68.23	31.27
5	4824.00	58.9 PK	74.0	-15.1	1.07 V	89	19.48	39.42
6	4824.00	47.8 AV	54.0	-6.2	1.07 V	89	8.38	39.42

- REMARKS:**
1. Emission level (dBuV/m) = Raw Value (dBuV) + Correction Factor (dB/m).
  2. Correction Factor (dB/m) = Antenna Factor (dB/m) + Cable Factor (dB).
  3. The other emission levels were very low against the limit.
  4. Margin value = Emission level – Limit value.
  5. “ \* “: Fundamental frequency.



A D T

EUT TEST CONDITION		MEASUREMENT DETAIL	
CHANNEL	Channel 6	FREQUENCY RANGE	1 ~ 25GHz
INPUT POWER	120V / 60Hz	DETECTOR FUNCTION	Peak (PK) Average (AV)
ENVIRONMENTAL CONDITIONS	21deg. C, 66%RH 1023 hPa	TESTED BY	Frank Liu

**ANTENNA POLARITY & TEST DISTANCE: HORIZONTAL AT 3 M**

NO.	FREQ. (MHz)	EMISSION LEVEL (dBuV/m)	LIMIT (dBuV/m)	MARGIN (dB)	ANTENNA HEIGHT (m)	TABLE ANGLE (Degree)	RAW VALUE (dBuV)	CORRECTION FACTOR (dB/m)
1	*2437.00	102.7 PK			1.21 H	146	73.97	28.73
2	*2437.00	90.4 AV			1.21 H	146	61.67	28.73
3	4874.00	54.7 PK	74.0	-19.3	1.00 H	154	24.16	30.54
4	4874.00	42.6 AV	54.0	-11.4	1.00 H	154	12.06	30.54
5	7311.00	54.9 PK	74.0	-19.1	1.21 H	249	22.89	32.01
6	7311.00	43.1 AV	54.0	-10.9	1.21 H	249	11.09	32.01

**ANTENNA POLARITY & TEST DISTANCE: VERTICAL AT 3 M**

NO.	FREQ. (MHz)	EMISSION LEVEL (dBuV/m)	LIMIT (dBuV/m)	MARGIN (dB)	ANTENNA HEIGHT (m)	TABLE ANGLE (Degree)	RAW VALUE (dBuV)	CORRECTION FACTOR (dB/m)
1	*2437.00	112.1 PK			1.00 V	243	80.76	31.34
2	*2437.00	99.7 AV			1.00 V	243	68.36	31.34
3	4874.00	58.6 PK	74.0	-15.4	1.07 V	79	18.98	39.62
4	4874.00	47.4 AV	54.0	-6.6	1.07 V	79	7.78	39.62
5	7311.00	53.1 PK	74.0	-20.9	1.46 V	157	9.00	44.10
6	7311.00	42.6 AV	54.0	-11.4	1.46 V	157	-1.50	44.10

- REMARKS:**
1. Emission level (dBuV/m) = Raw Value (dBuV) + Correction Factor (dB/m).
  2. Correction Factor (dB/m) = Antenna Factor (dB/m) + Cable Factor (dB).
  3. The other emission levels were very low against the limit.
  4. Margin value = Emission level – Limit value.
  5. “ \* “: Fundamental frequency.



A D T

EUT TEST CONDITION		MEASUREMENT DETAIL	
CHANNEL	Channel 11	FREQUENCY RANGE	1 ~ 25GHz
INPUT POWER	120V / 60Hz	DETECTOR FUNCTION	Peak (PK) Average (AV)
ENVIRONMENTAL CONDITIONS	21deg. C, 66%RH 1023 hPa	TESTED BY	Frank Liu

**ANTENNA POLARITY & TEST DISTANCE: HORIZONTAL AT 3 M**

NO.	FREQ. (MHz)	EMISSION LEVEL (dBuV/m)	LIMIT (dBuV/m)	MARGIN (dB)	ANTENNA HEIGHT (m)	TABLE ANGLE (Degree)	RAW VALUE (dBuV)	CORRECTION FACTOR (dB/m)
1	*2462.00	102.1 PK			1.21 H	143	73.35	28.75
2	*2462.00	90.2 AV			1.21 H	143	61.45	28.75
3	2483.50	61.3 PK	74.0	-12.7	1.00 H	147	32.53	28.77
4	2483.50	46.0 AV	54.0	-8.0	1.00 H	147	17.23	28.77
5	4924.00	54.3 PK	74.0	-19.7	1.00 H	104	23.73	30.57
6	4924.00	42.4 AV	54.0	-11.6	1.00 H	104	11.83	30.57
7	7386.00	54.7 PK	74.0	-19.3	1.14 H	241	22.66	32.04
8	7386.00	42.9 AV	54.0	-11.1	1.14 H	241	10.86	32.04

**ANTENNA POLARITY & TEST DISTANCE: VERTICAL AT 3 M**

NO.	FREQ. (MHz)	EMISSION LEVEL (dBuV/m)	LIMIT (dBuV/m)	MARGIN (dB)	ANTENNA HEIGHT (m)	TABLE ANGLE (Degree)	RAW VALUE (dBuV)	CORRECTION FACTOR (dB/m)
1	*2462.00	111.0 PK			1.00 V	283	79.60	31.40
2	*2462.00	99.2 AV			1.00 V	283	67.80	31.40
3	2483.50	69.7 PK	74.0	-4.3	1.00 V	339	38.24	31.46
4	2483.50	51.7 AV	54.0	-2.3	1.00 V	339	20.24	31.46
5	4924.00	58.4 PK	74.0	-15.6	1.03 V	64	18.58	39.82
6	4924.00	47.2 AV	54.0	-6.8	1.03 V	64	7.38	39.82
7	7386.00	52.7 PK	74.0	-21.3	1.43 V	162	8.52	44.18
8	7386.00	42.4 AV	54.0	-11.6	1.43 V	162	-1.78	44.18

- REMARKS:**
1. Emission level (dBuV/m) = Raw Value (dBuV) + Correction Factor (dB/m).
  2. Correction Factor (dB/m) = Antenna Factor (dB/m) + Cable Factor (dB).
  3. The other emission levels were very low against the limit.
  4. Margin value = Emission level – Limit value.
  5. “ \* “: Fundamental frequency.



A D T

RESTRICTED BANDEDGE (802.11n (20MHz) MODE,CH1, HORIZONTAL )

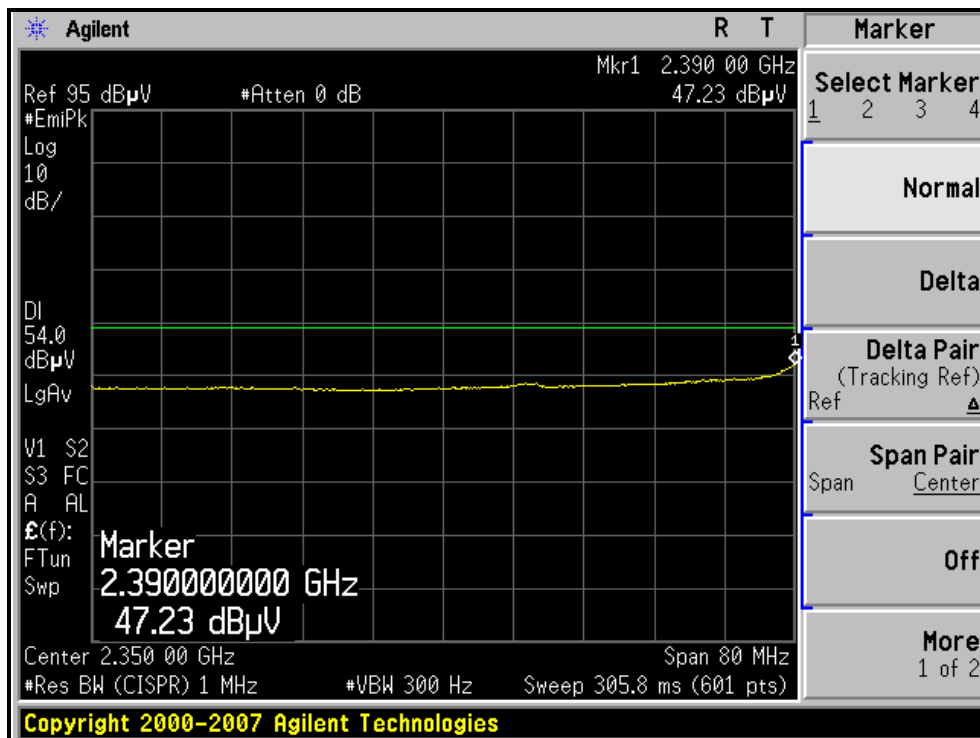
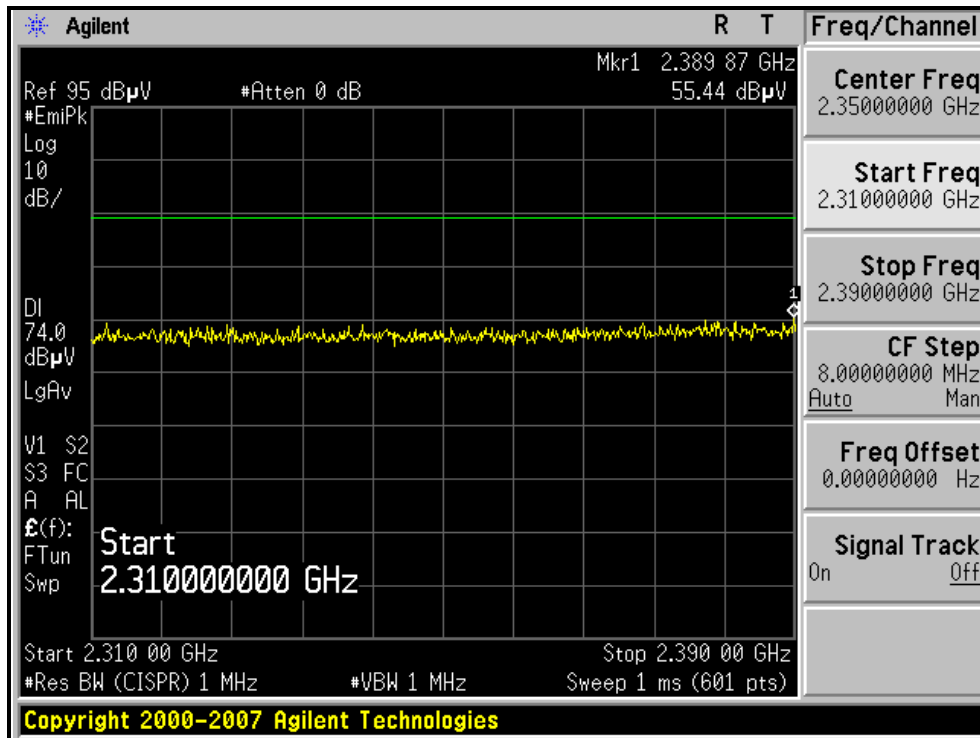



A D T

RESTRICTED BANDEDGE (802.11n (20MHz) MODE,CH1, VERTICAL )

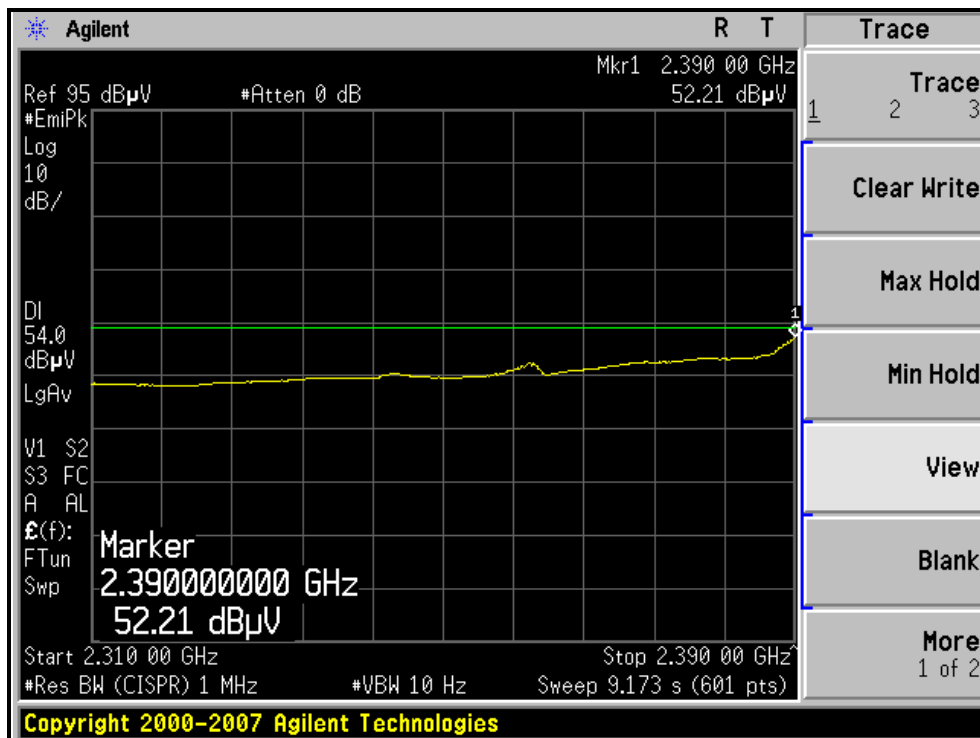
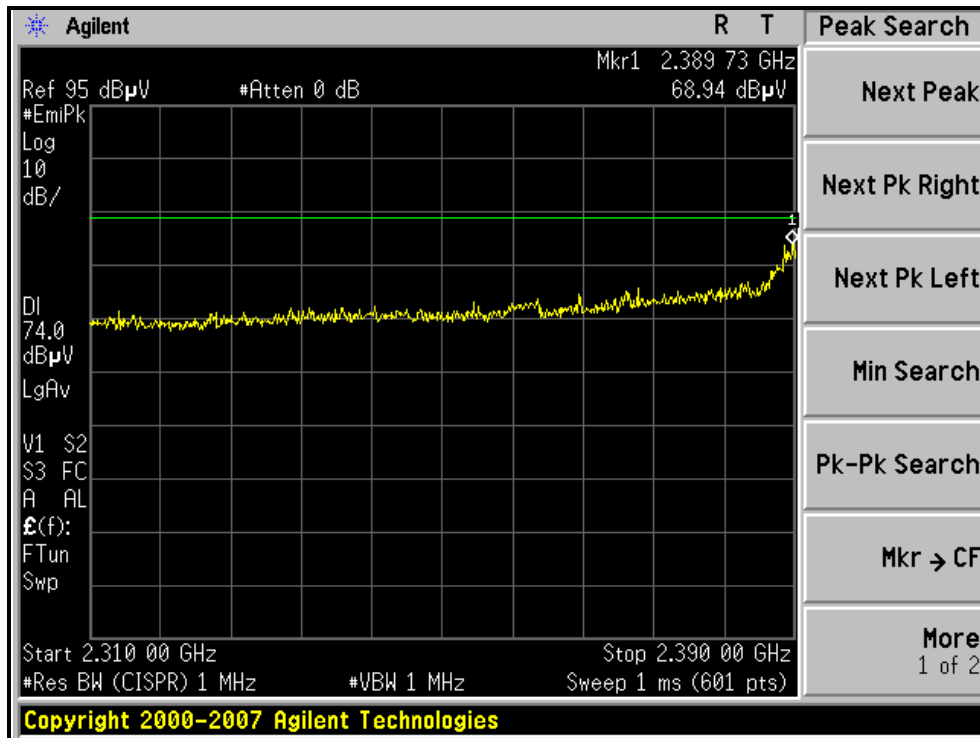





A D T

RESTRICTED BANDEDGE (802.11n (20MHz) MODE,CH11, HORIZONTAL )

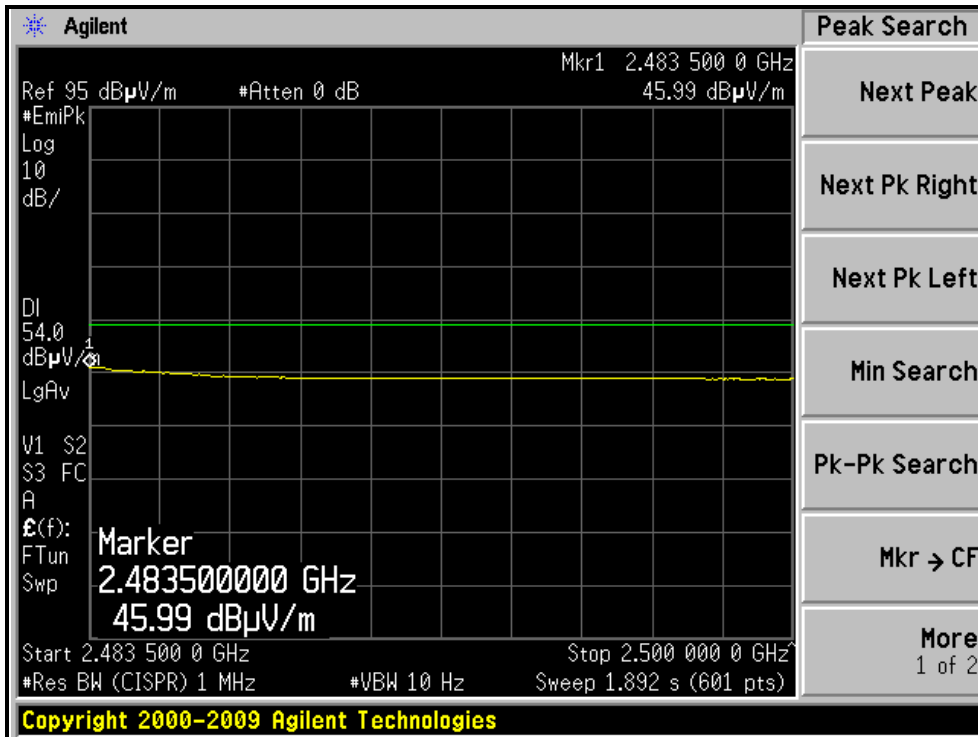
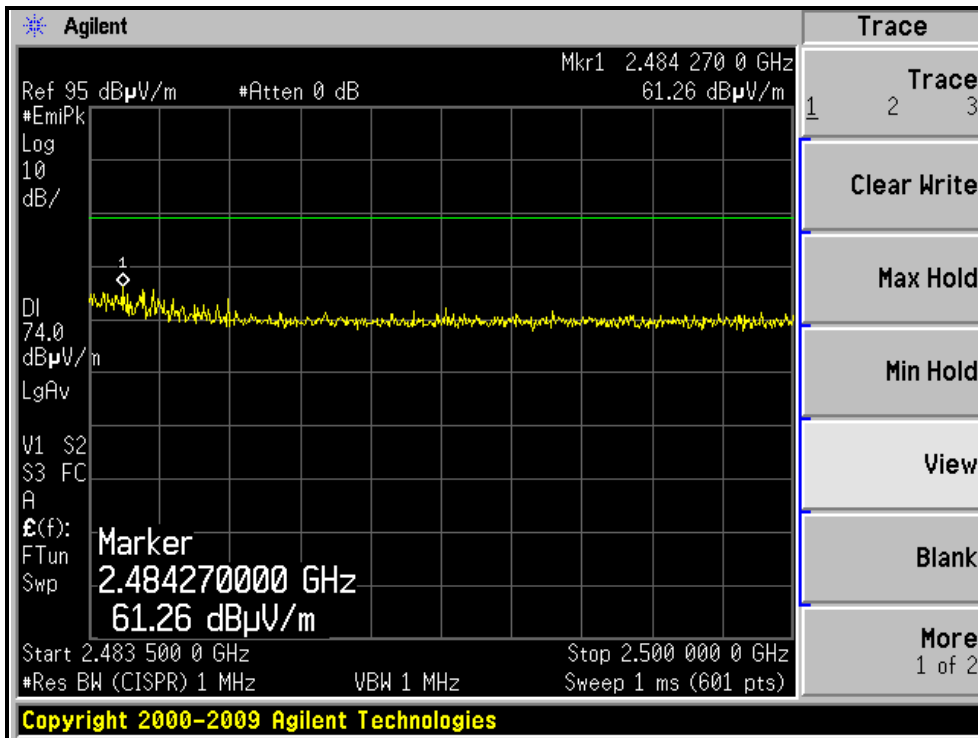



A D T

RESTRICTED BANDEDGE (802.11n (20MHz) MODE,CH11, VERTICAL )

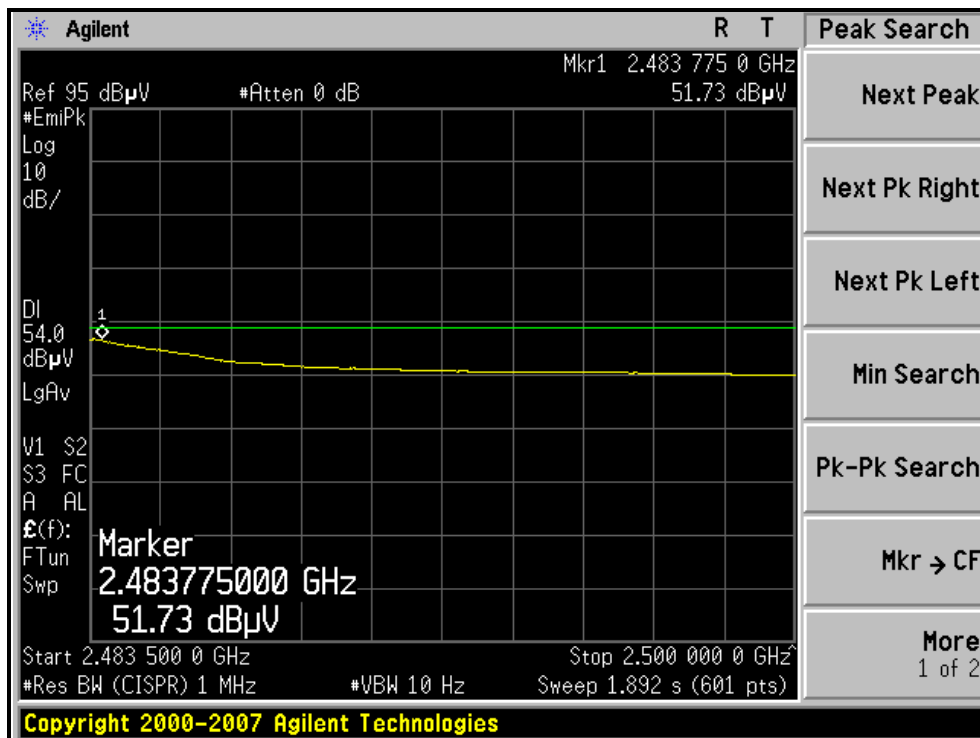
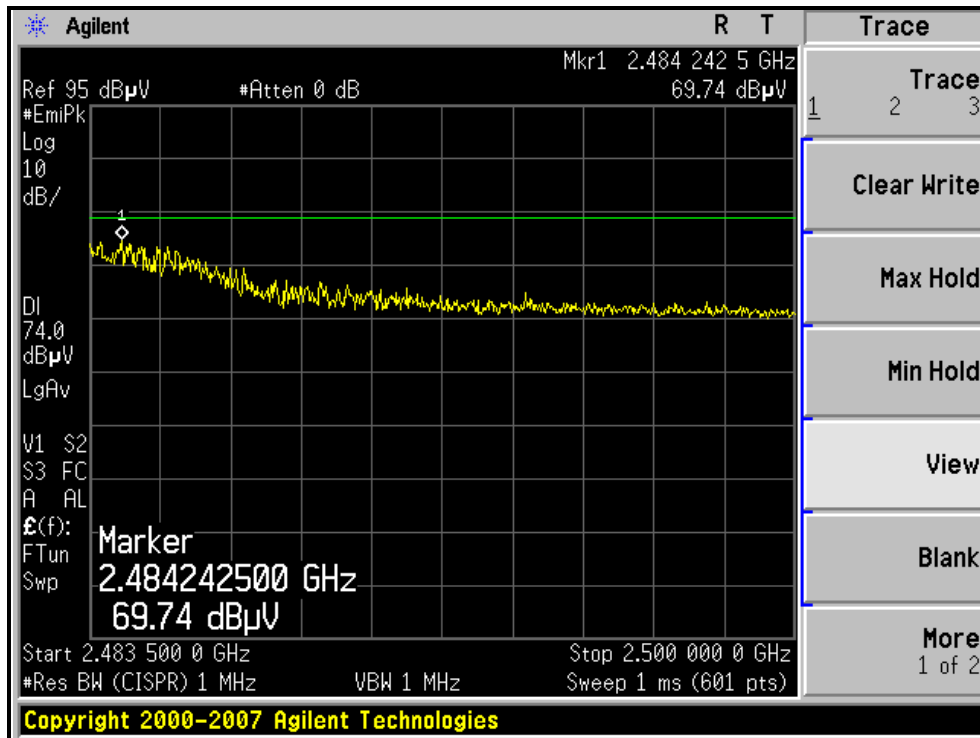



A D T

**802.11n (40MHz) OFDM MODULATION**

EUT TEST CONDITION		MEASUREMENT DETAIL	
CHANNEL	Channel 3	FREQUENCY RANGE	1 ~ 25GHz
INPUT POWER	120V / 60Hz	DETECTOR FUNCTION	Peak (PK) Average (AV)
ENVIRONMENTAL CONDITIONS	21deg. C, 66%RH 1023 hPa	TESTED BY	Frank Liu

**ANTENNA POLARITY & TEST DISTANCE: HORIZONTAL AT 3 M**

NO.	FREQ. (MHz)	EMISSION LEVEL (dBuV/m)	LIMIT (dBuV/m)	MARGIN (dB)	ANTENNA HEIGHT (m)	TABLE ANGLE (Degree)	RAW VALUE (dBuV)	CORRECTION FACTOR (dB/m)
1	2390.00	59.3 PK	74.0	-14.7	1.00 H	134	30.62	28.68
2	2390.00	47.5 AV	54.0	-6.5	1.00 H	134	18.82	28.68
3	*2422.00	94.3 PK			1.00 H	124	65.59	28.71
4	*2422.00	84.6 AV			1.00 H	124	55.89	28.71
5	4844.00	55.3 PK	74.0	-18.7	1.04 H	103	24.78	30.52
6	4844.00	42.9 AV	54.0	-11.1	1.04 H	103	12.38	30.52
7	7266.00	54.2 PK	74.0	-19.8	1.12 H	243	22.21	31.99
8	7266.00	43.1 AV	54.0	-10.9	1.12 H	243	11.11	31.99

**ANTENNA POLARITY & TEST DISTANCE: VERTICAL AT 3 M**

NO.	FREQ. (MHz)	EMISSION LEVEL (dBuV/m)	LIMIT (dBuV/m)	MARGIN (dB)	ANTENNA HEIGHT (m)	TABLE ANGLE (Degree)	RAW VALUE (dBuV)	CORRECTION FACTOR (dB/m)
1	2390.00	68.0 PK	74.0	-6.0	1.00 V	283	36.79	31.21
2	2390.00	52.6 AV	54.0	-1.4	1.00 V	283	21.39	31.21
3	*2422.00	105.4 PK			1.00 V	282	74.10	31.30
4	*2422.00	93.3 AV			1.00 V	282	62.00	31.30
5	4844.00	58.4 PK	74.0	-15.6	1.04 V	49	18.90	39.50
6	4844.00	47.2 AV	54.0	-6.8	1.04 V	49	7.70	39.50
7	7266.00	53.1 PK	74.0	-20.9	1.37 V	152	9.04	44.06
8	7266.00	43.2 AV	54.0	-10.8	1.37 V	152	-0.86	44.06

- REMARKS:**
1. Emission level (dBuV/m) = Raw Value (dBuV) + Correction Factor (dB/m).
  2. Correction Factor (dB/m) = Antenna Factor (dB/m) + Cable Factor (dB).
  3. The other emission levels were very low against the limit.
  4. Margin value = Emission level – Limit value.
  5. “ \* “: Fundamental frequency.



A D T

EUT TEST CONDITION		MEASUREMENT DETAIL	
CHANNEL	Channel 6	FREQUENCY RANGE	1 ~ 25GHz
INPUT POWER	120V / 60Hz	DETECTOR FUNCTION	Peak (PK) Average (AV)
ENVIRONMENTAL CONDITIONS	21deg. C, 66%RH 1023 hPa	TESTED BY	Frank Liu

ANTENNA POLARITY & TEST DISTANCE: HORIZONTAL AT 3 M								
NO.	FREQ. (MHz)	EMISSION LEVEL (dBuV/m)	LIMIT (dBuV/m)	MARGIN (dB)	ANTENNA HEIGHT (m)	TABLE ANGLE (Degree)	RAW VALUE (dBuV)	CORRECTION FACTOR (dB/m)
1	*2437.00	94.8 PK			1.00 H	129	66.07	28.73
2	*2437.00	84.7 AV			1.00 H	129	55.97	28.73
3	4874.00	54.9 PK	74.0	-19.1	1.02 H	104	24.36	30.54
4	4874.00	42.7 AV	54.0	-11.3	1.02 H	104	12.16	30.54
5	7311.00	54.7 PK	74.0	-19.3	1.13 H	253	22.69	32.01
6	7311.00	43.4 AV	54.0	-10.6	1.13 H	253	11.39	32.01
ANTENNA POLARITY & TEST DISTANCE: VERTICAL AT 3 M								
NO.	FREQ. (MHz)	EMISSION LEVEL (dBuV/m)	LIMIT (dBuV/m)	MARGIN (dB)	ANTENNA HEIGHT (m)	TABLE ANGLE (Degree)	RAW VALUE (dBuV)	CORRECTION FACTOR (dB/m)
1	*2437.00	104.2 PK			1.00 V	263	72.86	31.34
2	*2437.00	93.1 AV			1.00 V	263	61.76	31.34
3	4874.00	58.6 PK	74.0	-15.4	1.02 V	49	18.98	39.62
4	4874.00	47.8 AV	54.0	-6.2	1.02 V	49	8.18	39.62
5	7311.00	52.9 PK	74.0	-21.1	1.42 V	143	8.80	44.10
6	7311.00	42.8 AV	54.0	-11.2	1.42 V	143	-1.30	44.10

- REMARKS:**
1. Emission level (dBuV/m) = Raw Value (dBuV) + Correction Factor (dB/m).
  2. Correction Factor (dB/m) = Antenna Factor (dB/m) + Cable Factor (dB).
  3. The other emission levels were very low against the limit.
  4. Margin value = Emission level – Limit value.
  5. “ \* “: Fundamental frequency.



A D T

EUT TEST CONDITION		MEASUREMENT DETAIL	
CHANNEL	Channel 9	FREQUENCY RANGE	1 ~ 25GHz
INPUT POWER	120V / 60Hz	DETECTOR FUNCTION	Peak (PK) Average (AV)
ENVIRONMENTAL CONDITIONS	21deg. C, 66%RH 1023 hPa	TESTED BY	Frank Liu

**ANTENNA POLARITY & TEST DISTANCE: HORIZONTAL AT 3 M**

NO.	FREQ. (MHz)	EMISSION LEVEL (dBuV/m)	LIMIT (dBuV/m)	MARGIN (dB)	ANTENNA HEIGHT (m)	TABLE ANGLE (Degree)	RAW VALUE (dBuV)	CORRECTION FACTOR (dB/m)
1	*2452.00	94.1 PK			1.00 H	153	65.36	28.74
2	*2452.00	84.3 AV			1.00 H	153	55.56	28.74
3	2483.50	62.0 PK	74.0	-12.0	1.00 H	153	33.23	28.77
4	2483.50	47.5 AV	54.0	-6.5	1.00 H	153	18.73	28.77
5	4904.00	54.8 PK	74.0	-19.2	1.04 H	102	24.25	30.55
6	4904.00	42.6 AV	54.0	-11.4	1.04 H	102	12.05	30.55
7	7356.00	54.8 PK	74.0	-19.2	1.12 H	243	22.77	32.03
8	7356.00	43.1 AV	54.0	-10.9	1.12 H	243	11.07	32.03

**ANTENNA POLARITY & TEST DISTANCE: VERTICAL AT 3 M**

NO.	FREQ. (MHz)	EMISSION LEVEL (dBuV/m)	LIMIT (dBuV/m)	MARGIN (dB)	ANTENNA HEIGHT (m)	TABLE ANGLE (Degree)	RAW VALUE (dBuV)	CORRECTION FACTOR (dB/m)
1	*2452.00	104.8 PK			1.00 V	282	73.42	31.38
2	*2452.00	92.0 AV			1.00 V	282	60.62	31.38
3	2483.50	69.8 PK	74.0	-4.2	1.00 V	338	38.34	31.46
4	<b>2483.50</b>	<b>53.4 AV</b>	<b>54.0</b>	<b>-0.6</b>	<b>1.00 V</b>	<b>338</b>	<b>21.94</b>	<b>31.46</b>
5	4904.00	58.2 PK	74.0	-15.8	1.01 V	54	18.46	39.74
6	4904.00	47.4 AV	54.0	-6.6	1.01 V	54	7.66	39.74
7	7356.00	52.8 PK	74.0	-21.2	1.48 V	157	8.65	44.15
8	7356.00	42.6 AV	54.0	-11.4	1.48 V	157	-1.55	44.15

- REMARKS:**
1. Emission level (dBuV/m) = Raw Value (dBuV) + Correction Factor (dB/m).
  2. Correction Factor (dB/m) = Antenna Factor (dB/m) + Cable Factor (dB).
  3. The other emission levels were very low against the limit.
  4. Margin value = Emission level – Limit value.
  5. “ \* “: Fundamental frequency.



A D T

RESTRICTED BANDEDGE (802.11n (40MHz) MODE,CH3, HORIZONTAL )

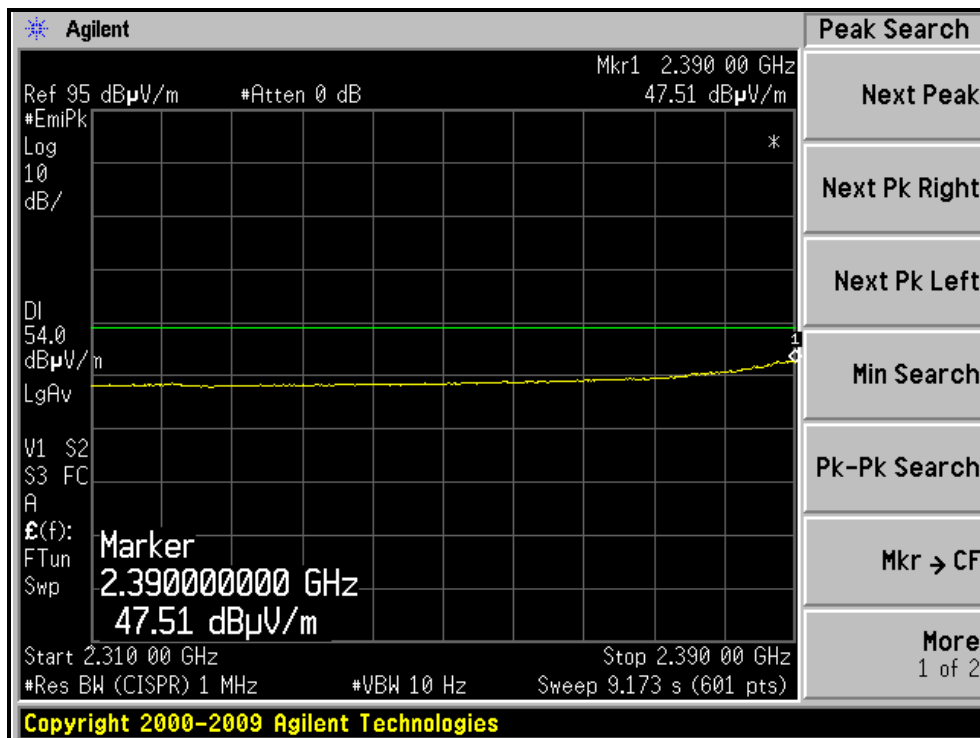
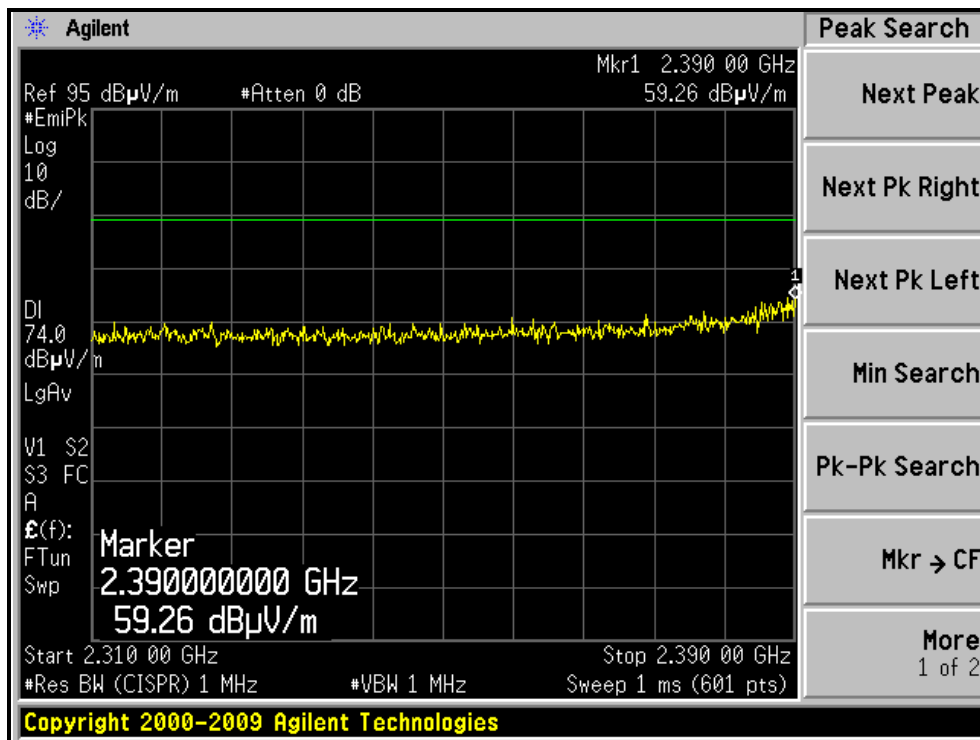

RESTRICTED BANDEDGE (802.11n (40MHz) MODE,CH3, VERTICAL )

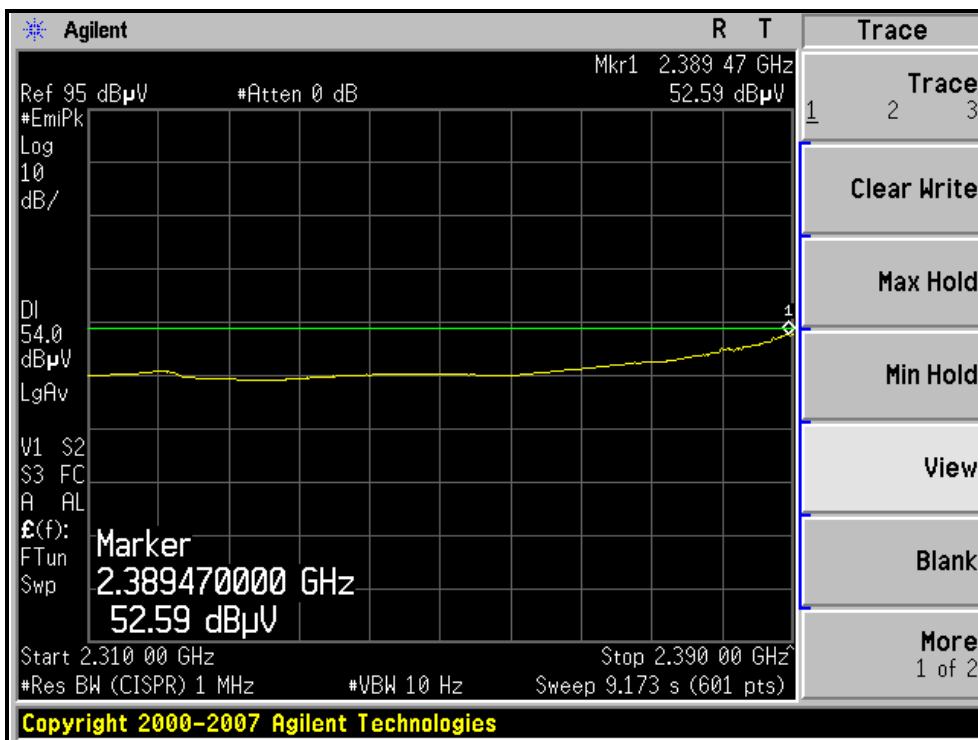
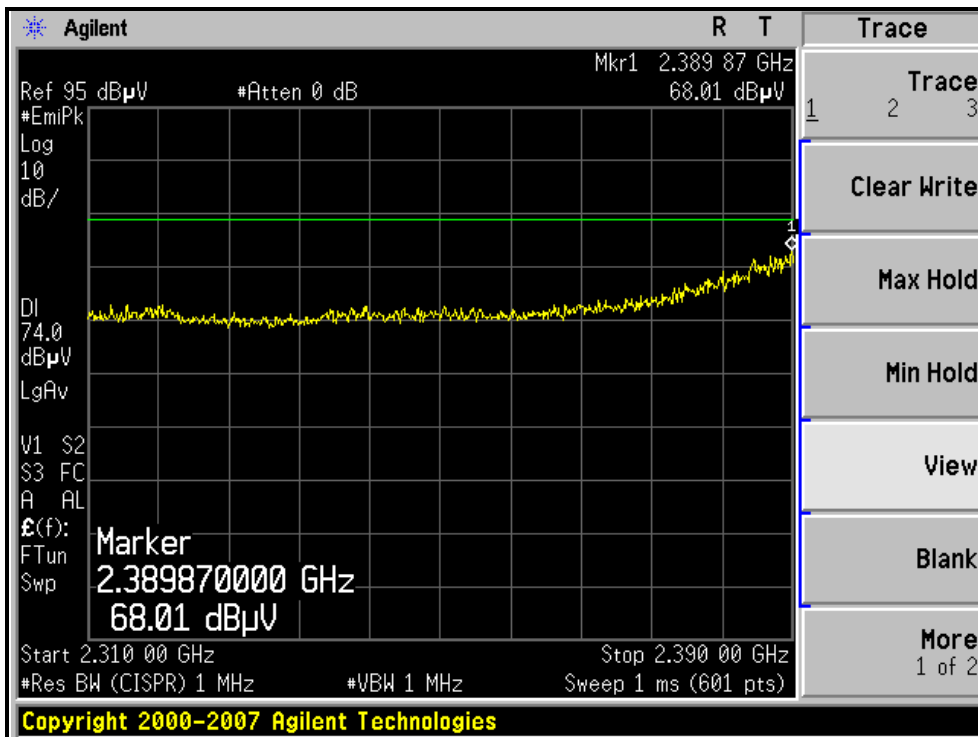

RESTRICTED BANDEDGE (802.11n (40MHz) MODE,CH9, HORIZONTAL )

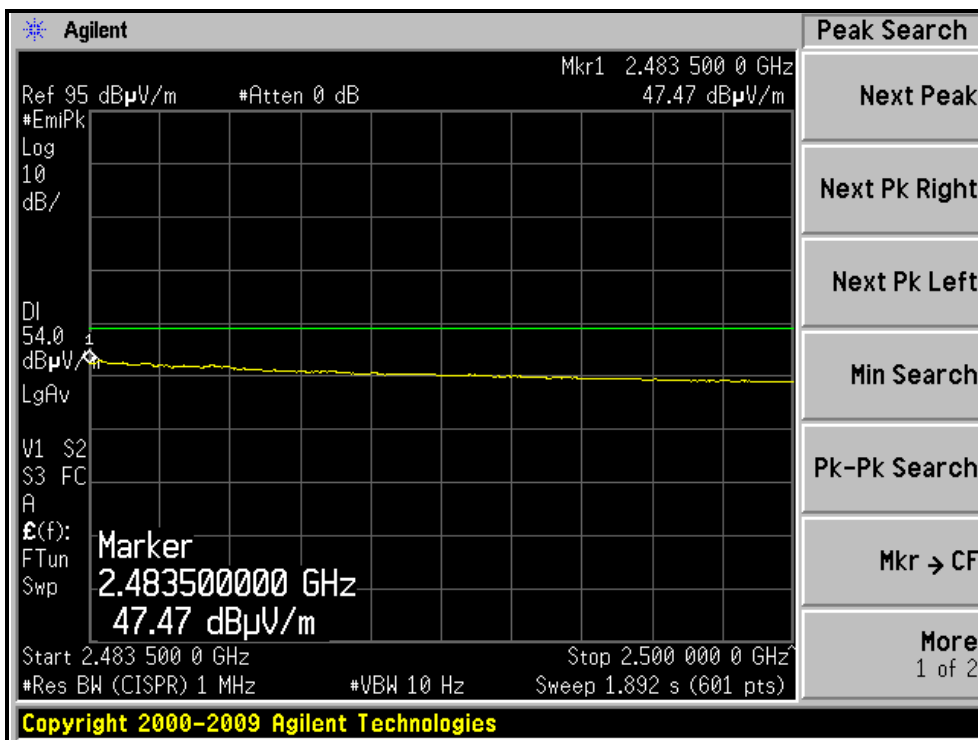
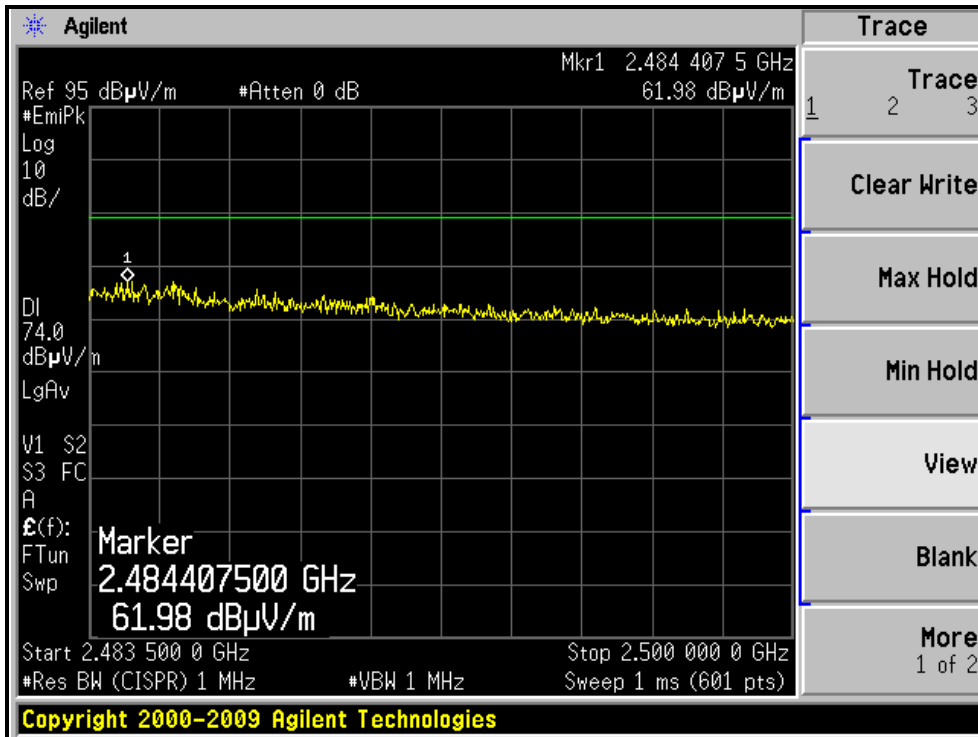





A D T

RESTRICTED BANDEDGE (802.11n (40MHz) MODE,CH9, VERTICAL )

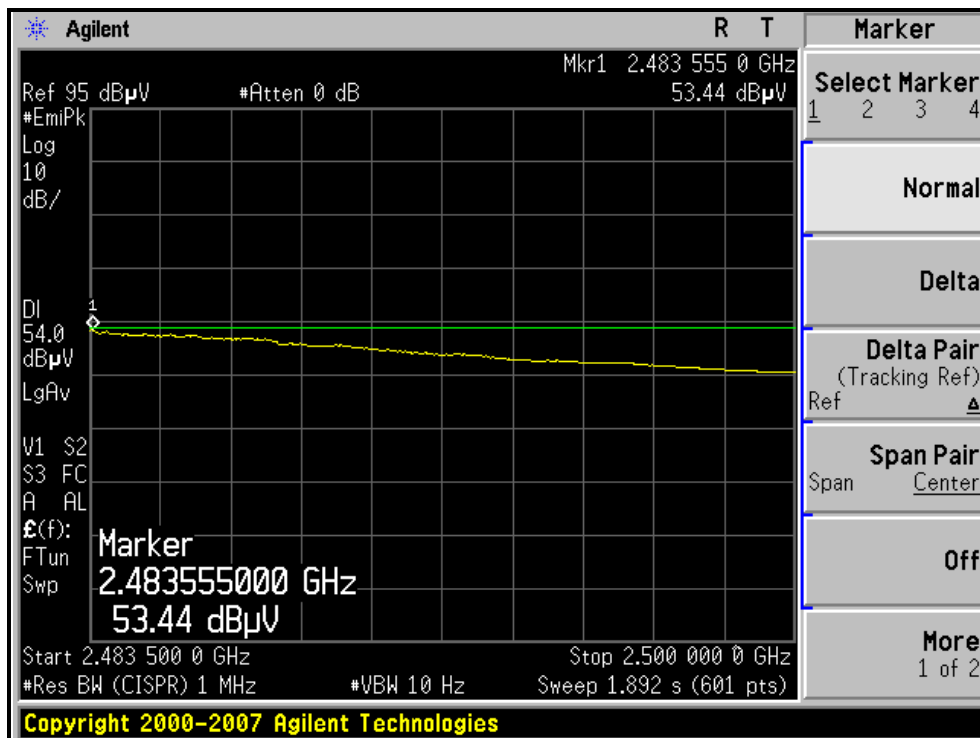
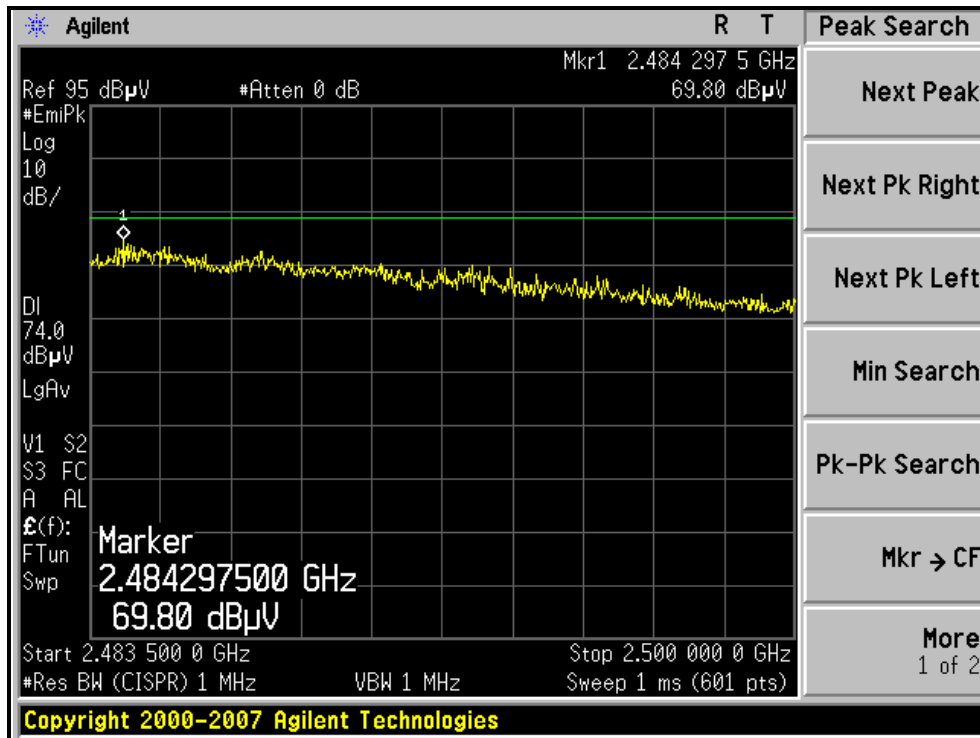

### 4.3 6dB BANDWIDTH MEASUREMENT

#### 4.3.1 LIMITS OF 6dB BANDWIDTH MEASUREMENT

The minimum of 6dB Bandwidth Measurement is 0.5 MHz.

#### 4.3.2 TEST INSTRUMENTS

DESCRIPTION & MANUFACTURER	MODEL NO.	SERIAL NO.	CALIBRATED DATE	CALIBRATED UNTIL
Spectrum Analyzer R&S	FSP 40	100060	May 17, 2010	May 16, 2011

**NOTE:**

1. The calibration interval of the above test instruments is 12 months and the calibrations are traceable to NML/ROC and NIST/USA.

#### 4.3.3 TEST PROCEDURE

The transmitter output was connected to the spectrum analyzer through an attenuator. The bandwidth of the fundamental frequency was measured by spectrum analyzer with 100kHz RBW and 300kHz VBW. The 6dB bandwidth is defined as the total spectrum the power of which is higher than peak power minus 6dB.

#### 4.3.4 DEVIATION FROM TEST STANDARD

No deviation

#### 4.3.5 TEST SETUP



#### 4.3.6 EUT OPERATING CONDITIONS

The software provided by client to enable the EUT under transmission condition continuously at lowest, middle and highest channel frequencies individually.

### 4.3.7 TEST RESULTS

#### 802.11b DSSS MODULATION:

CHANNEL	CHANNEL FREQUENCY (MHz)	6dB BANDWIDTH (MHz)	MINIMUM LIMIT (MHz)	PASS / FAIL
1	2412	11.55	0.5	PASS
6	2437	11.28	0.5	PASS
11	2462	11.6	0.5	PASS

#### CH11

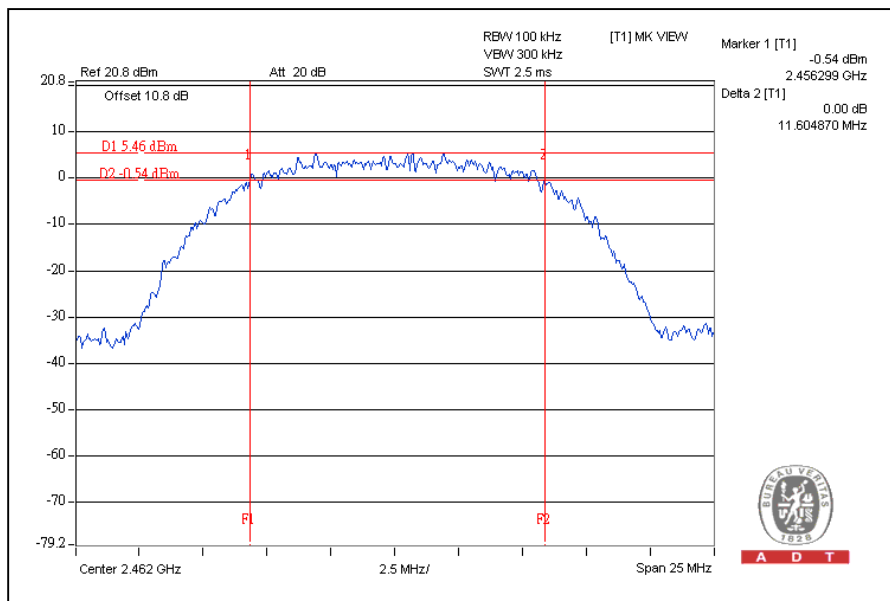



A D T

### 802.11g OFDM MODULATION:

CHANNEL	CHANNEL FREQUENCY (MHz)	6dB BANDWIDTH (MHz)	MINIMUM LIMIT (MHz)	PASS / FAIL
1	2412	16.34	0.5	PASS
6	2437	16.36	0.5	PASS
11	2462	15.92	0.5	PASS

### CH6

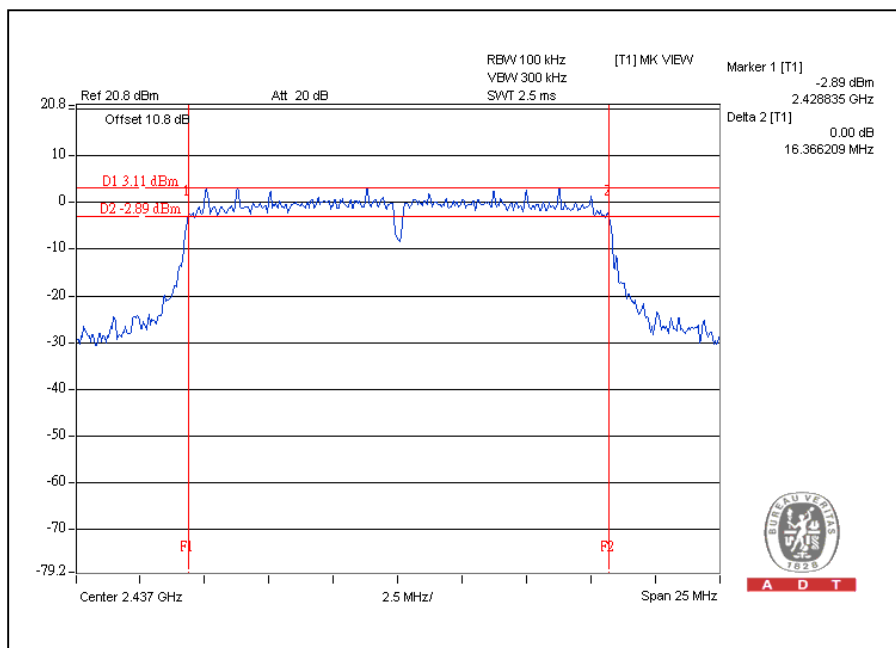



A D T

### 802.11n (20MHz) OFDM MODULATION:

CHANNEL	CHANNEL FREQUENCY (MHz)	6dB BANDWIDTH (MHz)	MINIMUM LIMIT (MHz)	PASS / FAIL
1	2412	16.31	0.5	PASS
6	2437	16.33	0.5	PASS
11	2462	16.33	0.5	PASS

### CH6

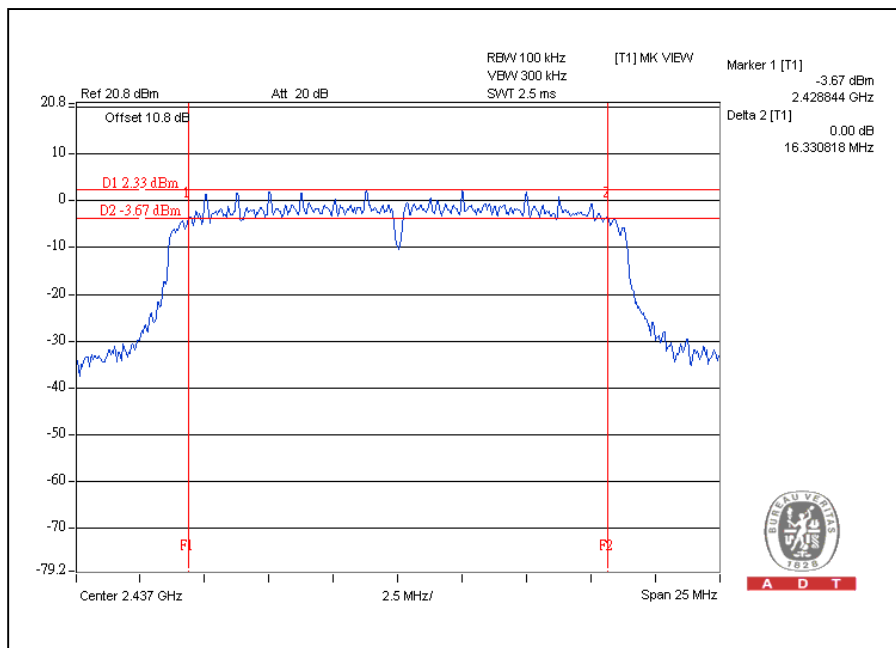

**802.11n (40MHz) OFDM MODULATION:**

CHANNEL	CHANNEL FREQUENCY (MHz)	6dB BANDWIDTH (MHz)	MINIMUM LIMIT (MHz)	PASS / FAIL
3	2422	34.59	0.5	PASS
6	2437	35.19	0.5	PASS
9	2452	35.26	0.5	PASS

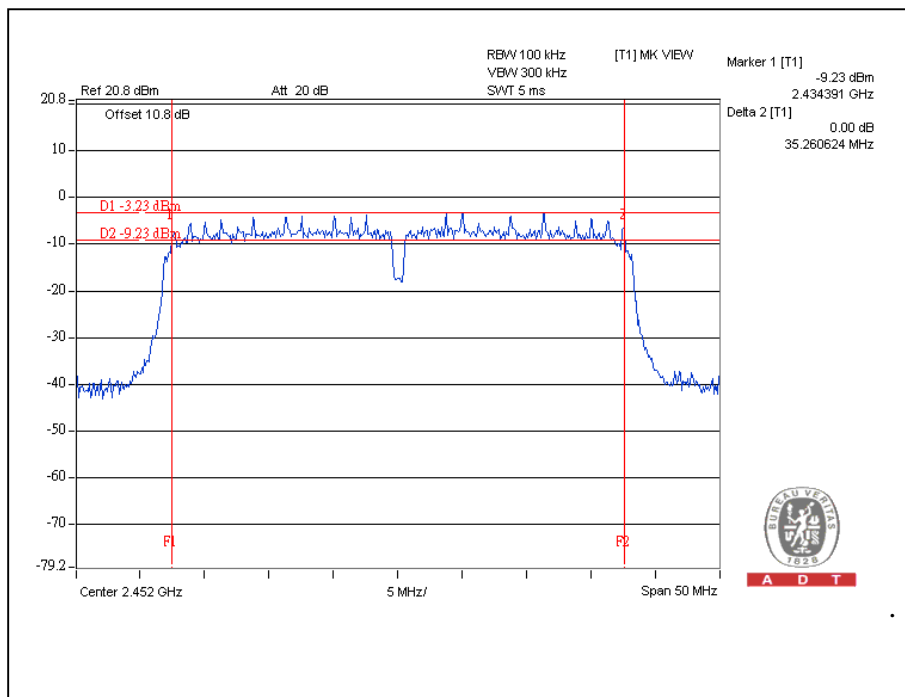
**CH9**

#### 4.4 MAXIMUM PEAK OUTPUT POWER

##### 4.4.1 LIMITS OF MAXIMUM PEAK OUTPUT POWER MEASUREMENT

The Maximum Peak Output Power Measurement is 30dBm.

##### 4.4.2 INSTRUMENTS

DESCRIPTION & MANUFACTURER	MODEL NO.	SERIAL NO.	CALIBRATED DATE	CALIBRATED UNTIL
Anritsu Power Meter	ML2495A	0824006	May 04, 2010	May 03, 2011
Pulse Power Sensor	MA2411B	0738172	May 04, 2010	May 03, 2011

**NOTE:**

The calibration interval of the above test instruments is 12 months and the calibrations are traceable to NML/ROC and NIST/USA.

##### 4.4.3 TEST PROCEDURES

1. The transmitter output was connected to the power meter through an attenuator; the bandwidth of the fundamental frequency was measured with the power meter.
2. Record the power level.

##### 4.4.4 DEVIATION FROM TEST STANDARD

No deviation

##### 4.4.5 TEST SETUP

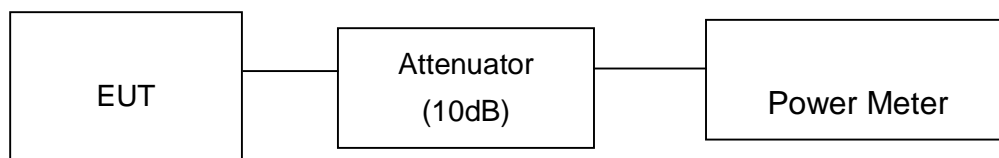

##### 4.4.6 EUT OPERATING CONDITIONS

Same as Item 4.3.6

#### 4.4.7 TEST RESULTS

##### 802.11b DSSS MODULATION:

CHANNEL	CHANNEL FREQUENCY (MHz)	PEAK POWER OUTPUT (mW)	PEAK POWER OUTPUT (dBm)	PEAK POWER LIMIT (dBm)	PASS / FAIL
1	2412	91.2	19.6	30	PASS
6	2437	93.3	19.7	30	PASS
11	2462	85.1	19.3	30	PASS

##### 802.11g OFDM MODULATION:

CHANNEL	CHANNEL FREQUENCY (MHz)	PEAK POWER OUTPUT (mW)	PEAK POWER OUTPUT (dBm)	PEAK POWER LIMIT (dBm)	PASS / FAIL
1	2412	102.3	20.1	30	PASS
6	2437	229.1	23.6	30	PASS
11	2462	125.9	21.0	30	PASS

##### 802.11n (20MHz) OFDM MODULATION:

CHANNEL	CHANNEL FREQUENCY (MHz)	PEAK POWER OUTPUT (dBm)		TOTAL PEAK POWER (mW)	TOTAL PEAK POWER (dBm)	PEAK POWER LIMIT (dBm)	PASS / FAIL
		CHAIN(0)	CHAIN(1)				
1	2412	22.2	22.4	339.7	25.3	30	PASS
6	2437	22.4	22.5	351.6	25.5	30	PASS
11	2462	22.3	22.3	339.6	25.3	30	PASS

##### 802.11n (40MHz) OFDM MODULATION:

CHANNEL	CHANNEL FREQUENCY (MHz)	PEAK POWER OUTPUT (dBm)		TOTAL PEAK POWER (mW)	TOTAL PEAK POWER (dBm)	PEAK POWER LIMIT (dBm)	PASS / FAIL
		CHAIN(0)	CHAIN(1)				
3	2422	20.4	20.6	224.5	23.5	30	PASS
6	2437	22.1	22.2	328.1	25.2	30	PASS
9	2452	20.7	19.9	215.2	23.3	30	PASS



## 4.5 POWER SPECTRAL DENSITY MEASUREMENT

### 4.5.1 LIMITS OF POWER SPECTRAL DENSITY MEASUREMENT

The Maximum of Power Spectral Density Measurement is 8dBm.

### 4.5.2 TEST INSTRUMENTS

DESCRIPTION & MANUFACTURER	MODEL NO.	SERIAL NO.	CALIBRATED DATE	CALIBRATED UNTIL
Spectrum Analyzer R&S	FSP 40	100060	May 17, 2010	May 16, 2011

**NOTE:**

1. The calibration interval of the above test instruments is 12 months and the calibrations are traceable to NML/ROC and NIST/USA.

### 4.5.3 TEST PROCEDURE

The transmitter output was connected to the spectrum analyzer through an attenuator, the bandwidth of the fundamental frequency was measured with the spectrum analyzer using 3kHz RBW and 30kHz VBW, set sweep time = span/3kHz. The power spectral density was measured and recorded. The sweep time is allowed to be longer than span/3kHz for a full response of the mixer in the spectrum analyzer.

### 4.5.4 DEVIATION FROM TEST STANDARD

No deviation

### 4.5.5 TEST SETUP

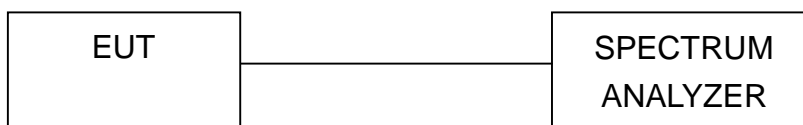

### 4.5.6 EUT OPERATING CONDITION

Same as Item 4.3.6



A D T

### 4.5.7 TEST RESULTS

#### 802.11b DSSS MODULATION:

CHANNEL	CHANNEL FREQUENCY (MHz )	RF POWER LEVEL IN 3kHz BW (dBm)	MAXIMUM LIMIT (dBm)	PASS / FAIL
1	2412	-8.1	8	PASS
6	2437	-8.0	8	PASS
11	2462	-7.8	8	PASS

#### CH11

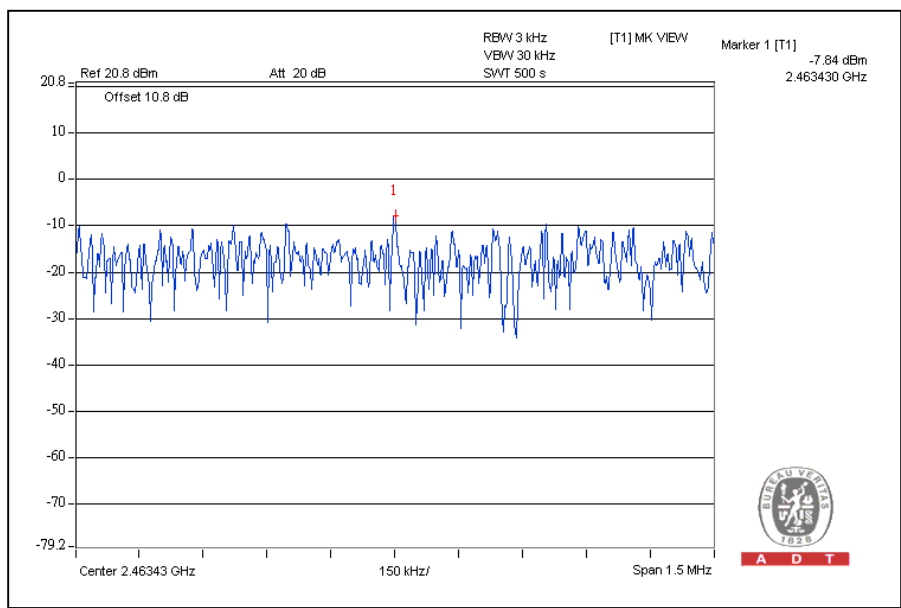



A D T

### 802.11g OFDM MODULATION:

CHANNEL	CHANNEL FREQUENCY (MHz )	RF POWER LEVEL IN 3kHz BW (dBm)	MAXIMUM LIMIT (dBm)	PASS / FAIL
1	2412	-12.4	8	PASS
6	2437	-11.5	8	PASS
11	2462	-13.3	8	PASS

### CH6

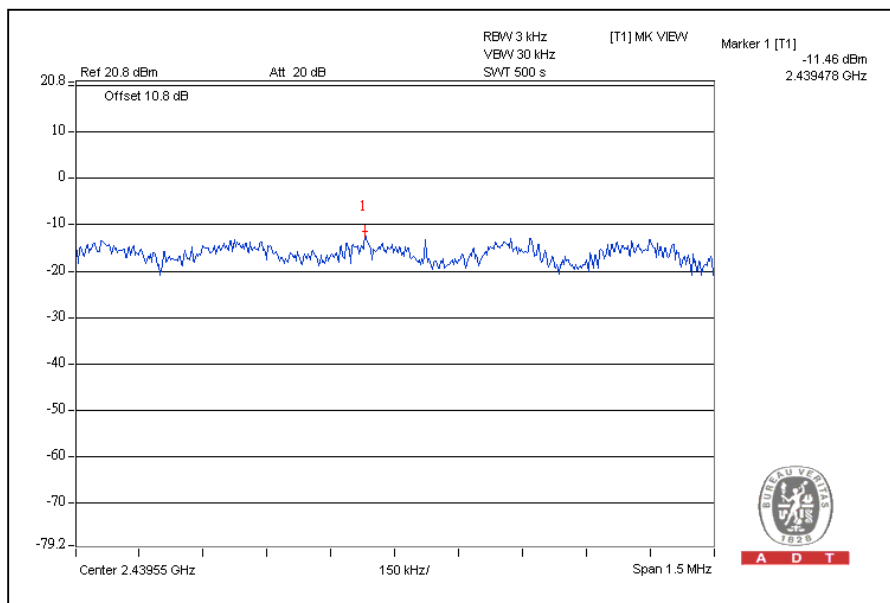



A D T

### 802.11n (20MHz) OFDM MODULATION:

CHANNEL	CHANNEL FREQUENCY (MHz)	RF POWER LEVEL IN 3kHz BW (dBm)		TOTAL POWER DENSITY (dBm)	MAXIMUM LIMIT (dBm)	PASS / FAIL
		CHAIN(0)	CHAIN(1)			
1	2412	-14.4	-9.8	-8.5	8	PASS
6	2437	-12.2	-8.8	-7.2	8	PASS
11	2462	-13.7	-9.9	-8.4	8	PASS

For Chain(1): CH6

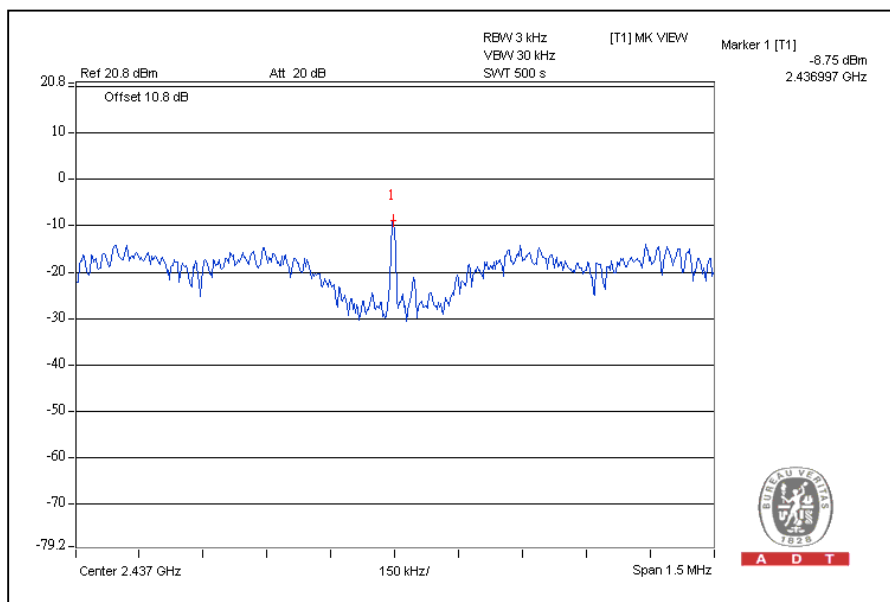



A D T

### 802.11n (40MHz) OFDM MODULATION:

CHANNEL	CHANNEL FREQUENCY (MHz)	RF POWER LEVEL IN 3kHz BW (dBm)		TOTAL POWER DENSITY (dBm)	MAXIMUM LIMIT (dBm)	PASS / FAIL
		CHAIN(0)	CHAIN(1)			
3	2422	-19.7	-11.8	-11.1	8	PASS
6	2437	-17.2	-8.5	-8.0	8	PASS
9	2452	-18.6	-19.3	-15.9	8	PASS

For Chain(1): CH6

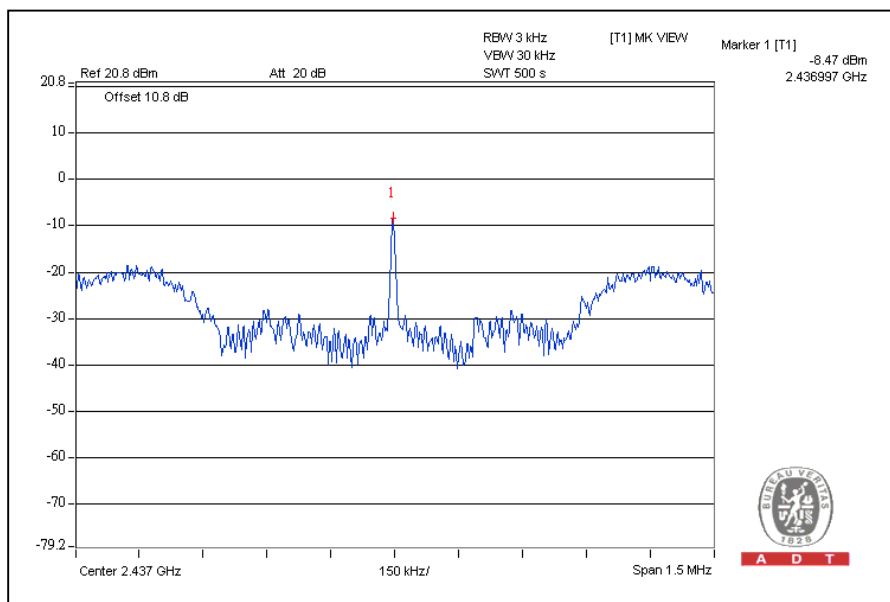

## 4.6 CONDUCTED OUT-BAND EMISSION MEASUREMENT

### 4.6.1 LIMITS OF CONDUCTED OUT-BAND EMISSION MEASUREMENT

Below  $-20\text{dB}$  of the highest emission level of operating band (in 100kHz Resolution Bandwidth).

### 4.6.2 TEST INSTRUMENTS

DESCRIPTION & MANUFACTURER	MODEL NO.	SERIAL NO.	CALIBRATED DATE	CALIBRATED UNTIL
Spectrum Analyzer R&S	FSP 40	100060	May 17, 2010	May 16, 2011

**NOTE:**

1. The calibration interval of the above test instruments is 12 months and the calibrations are traceable to NML/ROC and NIST/USA.

### 4.6.3 TEST PROCEDURE

The transmitter output was connected to the spectrum analyzer via a low loss cable. Set RBW of spectrum analyzer to 100kHz and VBW of spectrum analyzer to 300kHz with suitable frequency span including 100 MHz or 200 MHz bandwidth from band edge. The band edges was measured and recorded.

The spectrum plots (RBW = 100kHz, VBW = 300kHz) are attached on the following pages.

### 4.6.4 DEVIATION FROM TEST STANDARD

No deviation

### 4.6.5 EUT OPERATING CONDITION

Same as Item 4.3.6

### 4.6.6 TEST RESULTS

The spectrum plots are attached on the following images. D1 line indicates the highest level, and D2 line indicates the 20dB offset below D1. It shows compliance with the requirement in part 15.247(d).

## 802.11b DSSS MODULATION:

### CH1

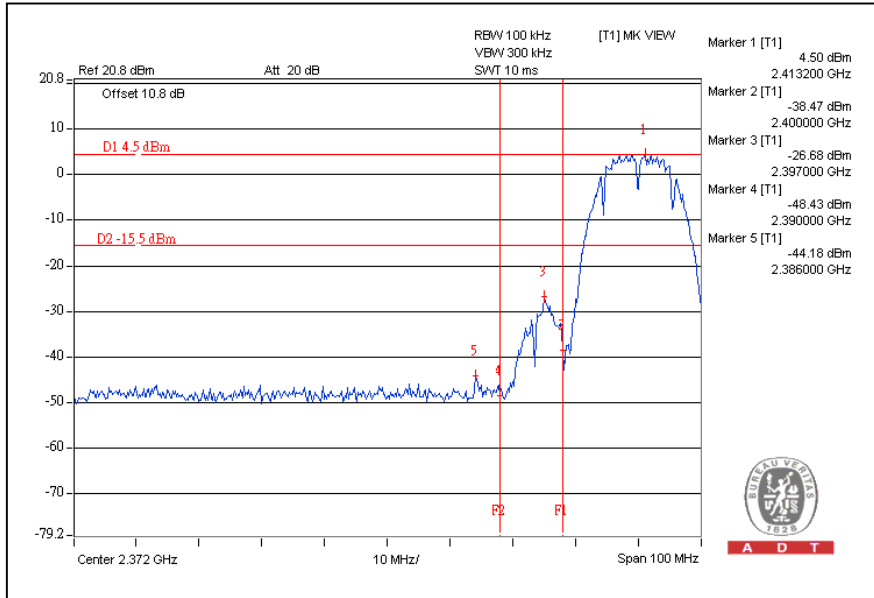

### CH11

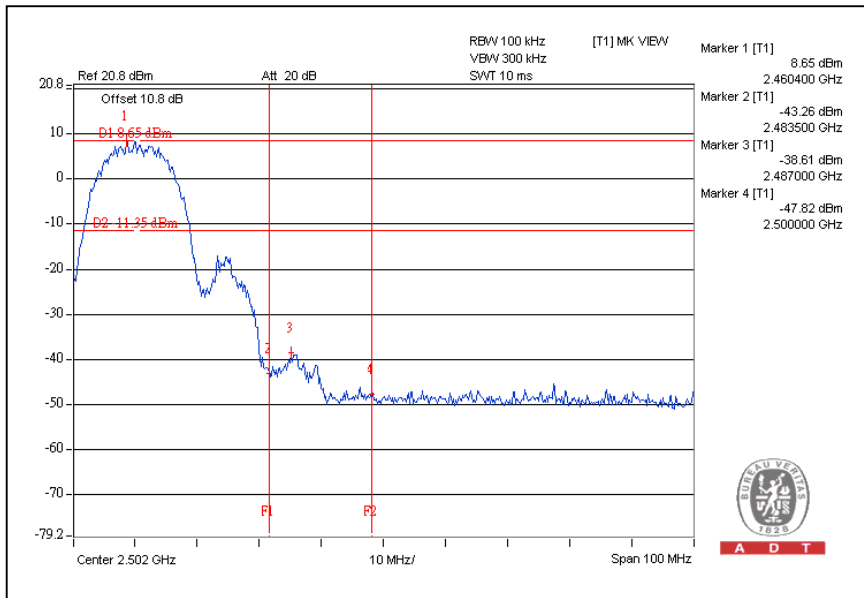



A D T

### CH1

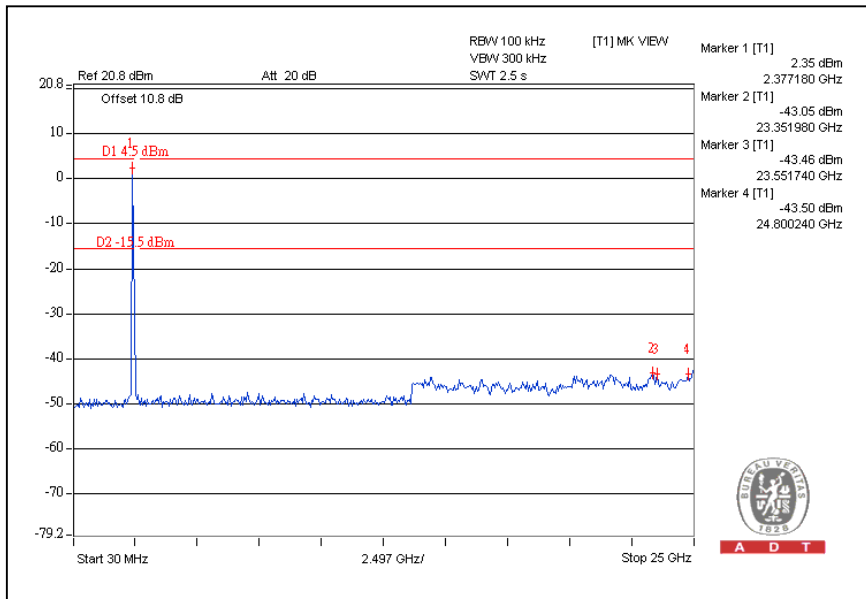

### CH11

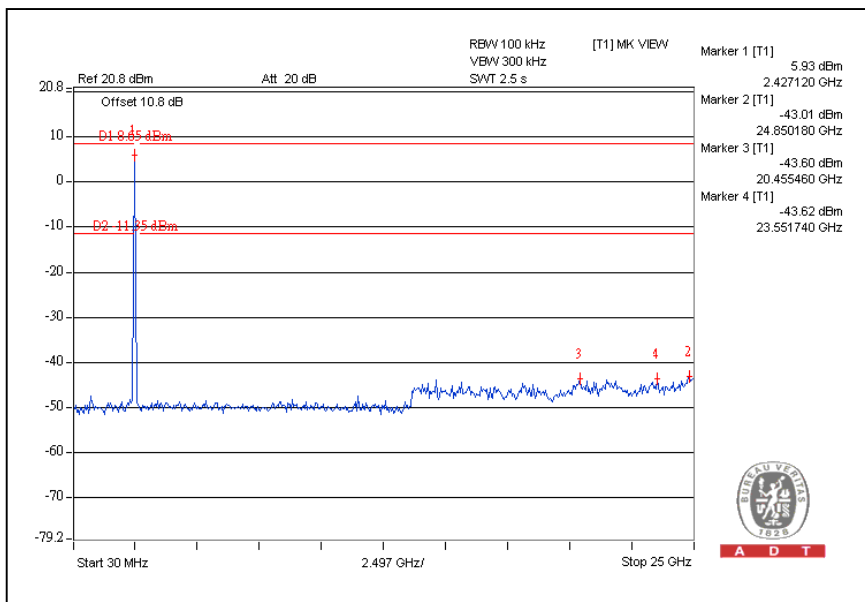



## 802.11g OFDM MODULATION:

### CH1

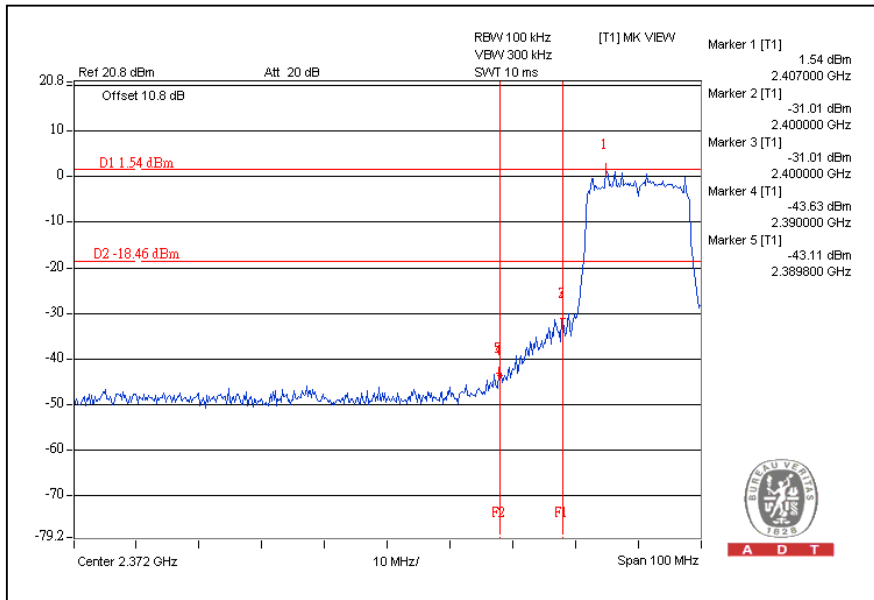

### CH11

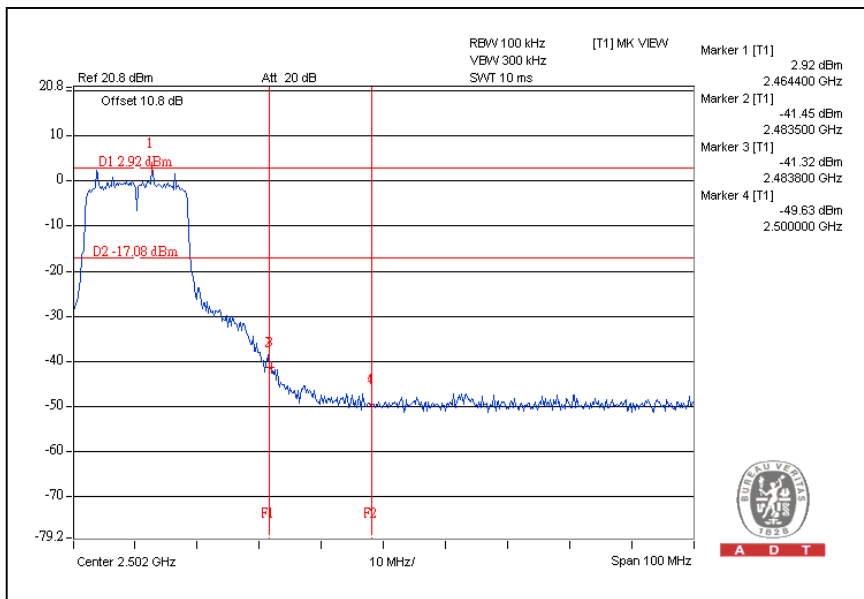



A D T

### CH1

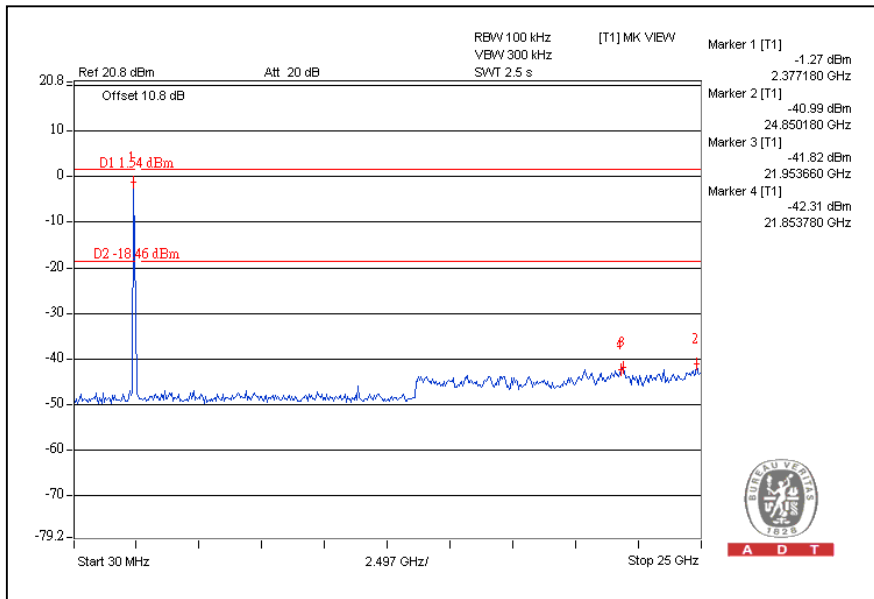

### CH11

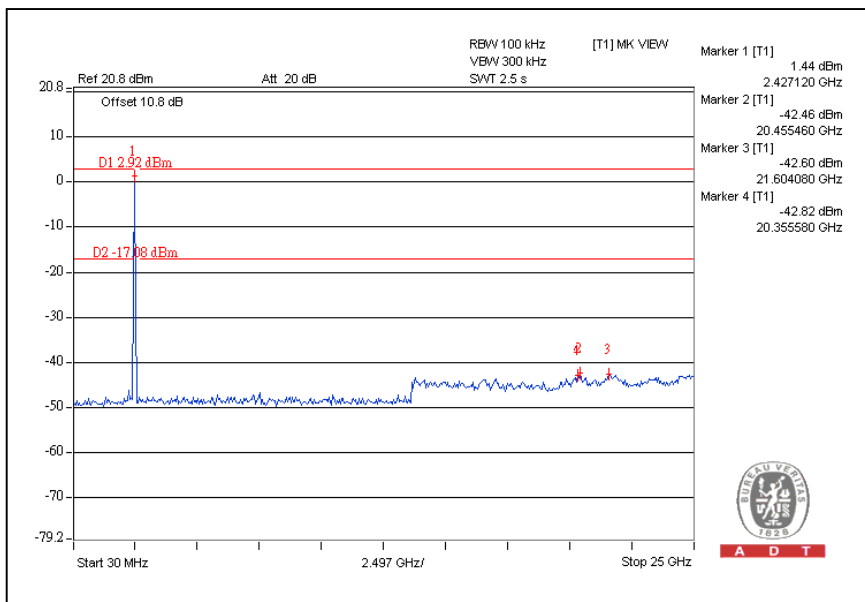

## 802.11n (20MHz) OFDM MODULATION:

### CH1

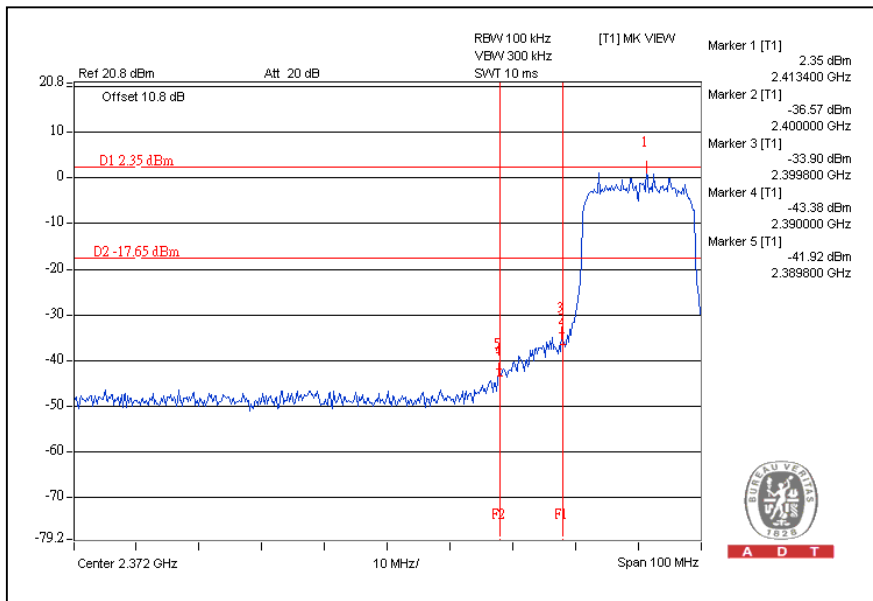

### CH11

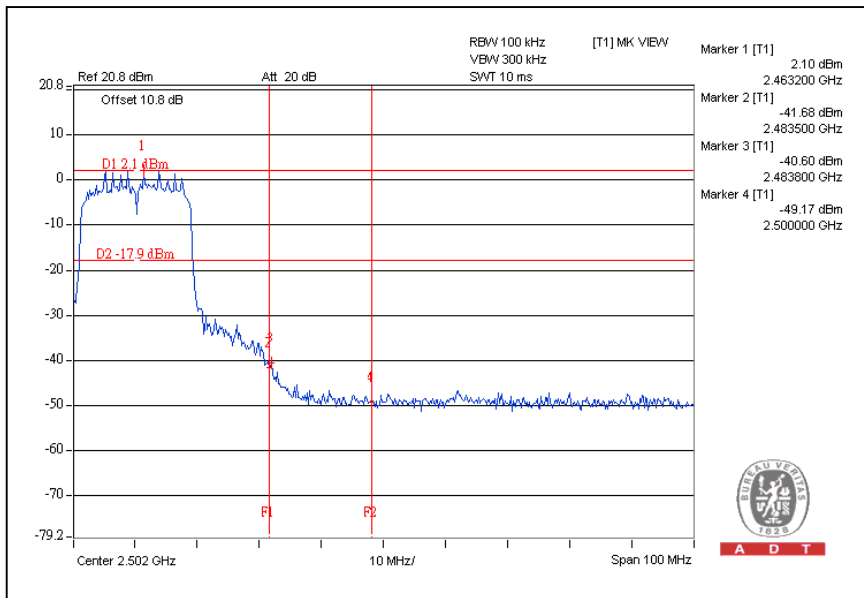



A D T

### CH1

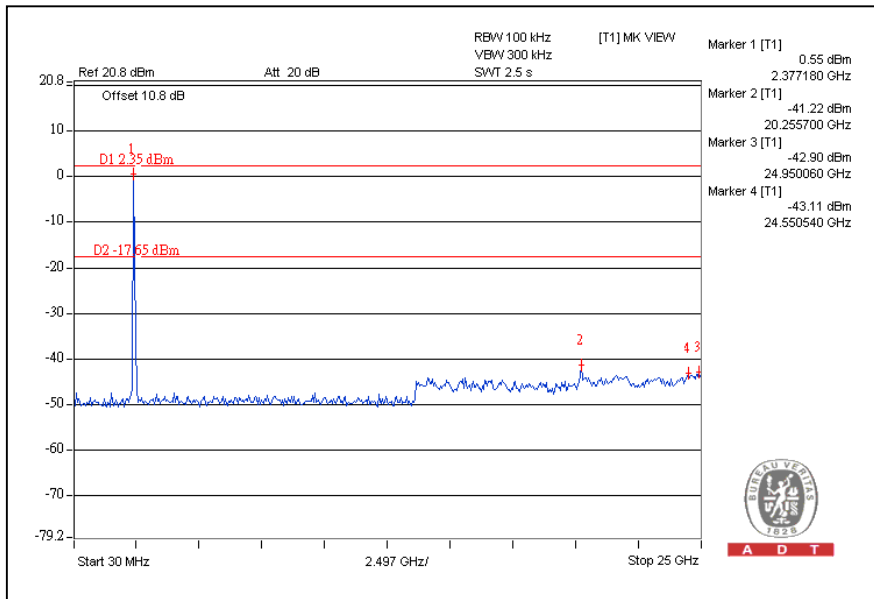

### CH11

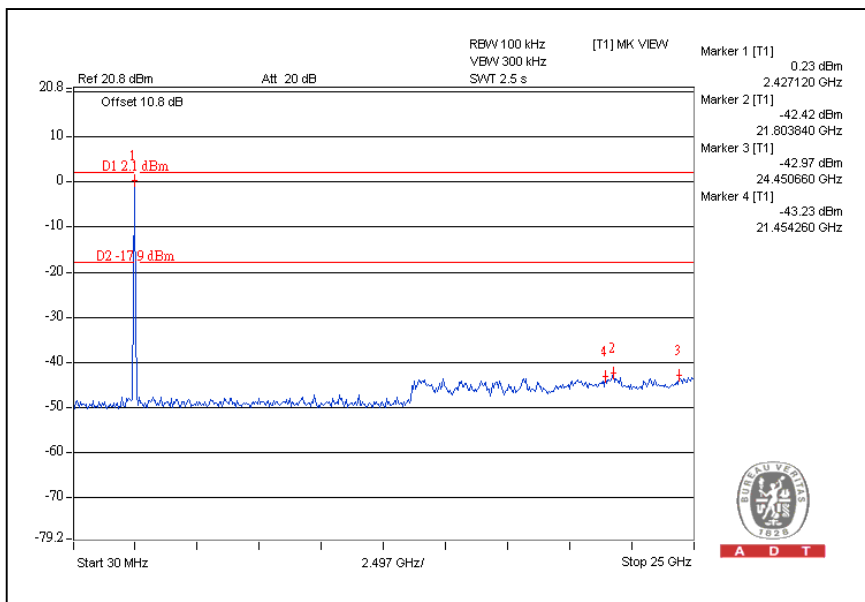

### 802.11n (40MHz) OFDM MODULATION:

#### CH3

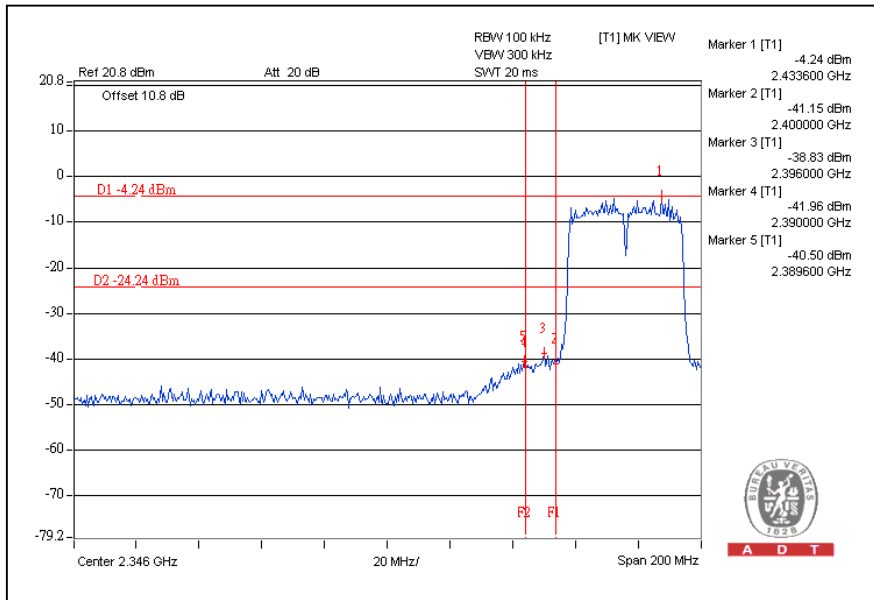

#### CH9

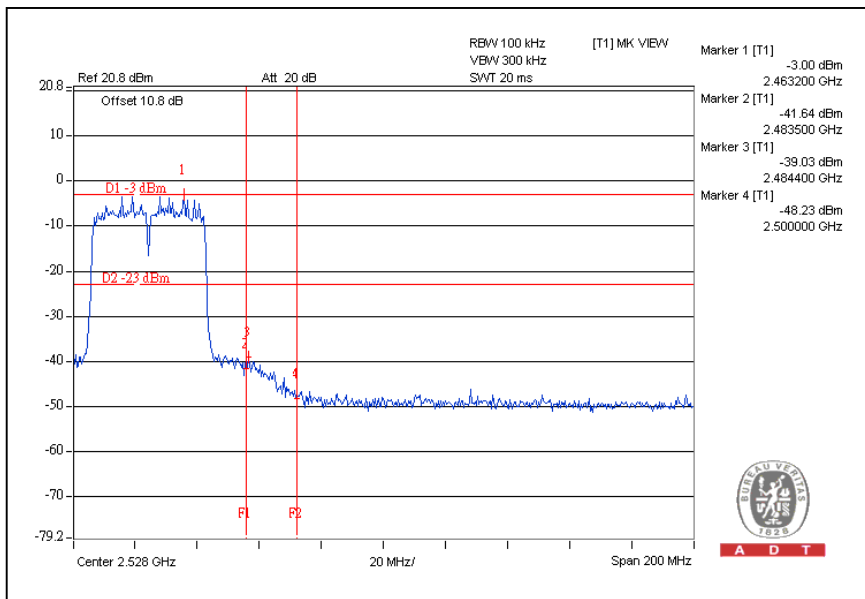



A D T

### CH3

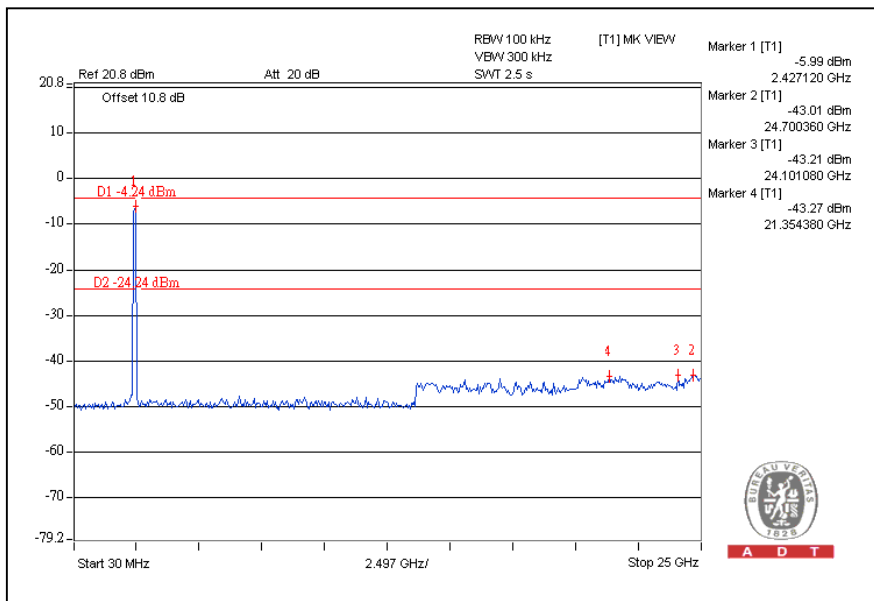

### CH9

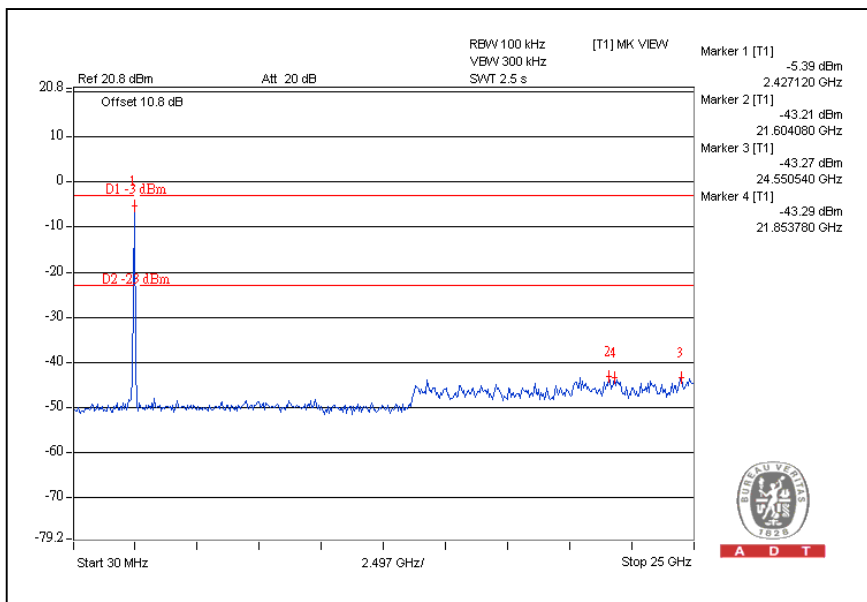



## 5. INFORMATION ON THE TESTING LABORATORIES

We, Bureau Veritas Consumer Products Services (H.K.) Ltd., Taoyuan Branch, were founded in 1988 to provide our best service in EMC, Radio, Telecom and Safety consultation. Our laboratories are accredited and approved according to ISO/IEC 17025:

Copies of accreditation certificates of our laboratories obtained from approval agencies can be downloaded from our web site: [www.adt.com.tw/index.5.phtml](http://www.adt.com.tw/index.5.phtml).

If you have any comments, please feel free to contact us at the following:

**Linko EMC/RF Lab:**

Tel: 886-2-26052180

Fax: 886-2-26052943

**Hsin Chu EMC/RF Lab:**

Tel: 886-3-5935343

Fax: 886-3-5935342

**Hwa Ya EMC/RF/Safety/Telecom Lab:**

Tel: 886-3-3183232

Fax: 886-3-3185050

**Email:** [service@adt.com.tw](mailto:service@adt.com.tw)

**Web Site:** [www.adt.com.tw](http://www.adt.com.tw)

The address and road map of all our labs can be found in our web site also.



A D T

## **6.APPENDIX A - MODIFICATIONS RECORDERS FOR ENGINEERING CHANGES TO THE EUT BY THE LAB**

No any modifications are made to the EUT by the lab during the test.

--- END ---