

FCC Test Report

Report No.: RF150825C34

FCC ID: KA2WL8710APA1

Test Model: DWL-8710AP

Received Date: Aug. 25, 2015

Test Date: Sep. 25 ~ Oct. 29, 2015

Issued Date: Nov. 05, 2015

Applicant: D-Link Corporation

Address: No.289, Xinhua 3rd Rd., Neihu District, Taipei City 11494, Taiwan, R.O.C.

Issued By: Bureau Veritas Consumer Products Services (H.K.) Ltd., Taoyuan Branch

Lab Address: No. 47-2, 14th Ling, Chia Pau Vil., Lin Kou Dist., New Taipei City, Taiwan (R.O.C.)

Test Location: No.19, Hwa Ya 2nd Rd., Wen Hwa Vil., Kwei Shan Dist., Taoyuan City 33383, TAIWAN (R.O.C.)



This report is for your exclusive use. Any copying or replication of this report to or for any other person or entity, or use of our name or trademark, is permitted only with our prior written permission. This report sets forth our findings solely with respect to the test samples identified herein. The results set forth in this report are not indicative or representative of the quality or characteristics of the lot from which a test sample was taken or any similar or identical product specifically and expressly noted. Our report includes all of the tests requested by you and the results thereof based upon the information that you provided to us. You have 60 days from date of issuance of this report to notify us of any material error or omission caused by our negligence, provided, however, that such notice shall be in writing and shall specifically address the issue you wish to raise. A failure to raise such issue within the prescribed time shall constitute your unqualified acceptance of the completeness of this report, the tests conducted and the correctness of the report contents. Unless specific mention, the uncertainty of measurement has been explicitly taken into account to declare the compliance or non-compliance to the specification. The report must not be used by the client to claim product certification, approval, or endorsement by TAF or any government agencies.

Table of Contents

Release Control Record	4
1 Certificate of Conformity	5
2 Summary of Test Results	6
2.1 Measurement Uncertainty	6
2.2 Modification Record	6
3 General Information	7
3.1 General Description of EUT	7
3.2 Description of Test Modes	8
3.2.1 Test Mode Applicability and Tested Channel Detail	9
3.3 Duty Cycle of Test Signal	11
3.4 Description of Support Units	12
3.4.1 Configuration of System under Test	12
3.5 General Description of Applied Standards	13
4 Test Types and Results	14
4.1 Radiated Emission and Bandedge Measurement.....	14
4.1.1 Limits of Radiated Emission and Bandedge Measurement	14
4.1.2 Test Instruments	15
4.1.3 Test Procedures.....	16
4.1.4 Deviation from Test Standard	16
4.1.5 Test Set Up	17
4.1.6 EUT Operating Conditions.....	17
4.1.7 Test Results	18
4.2 Conducted Emission Measurement	31
4.2.1 Limits of Conducted Emission Measurement	31
4.2.2 Test Instruments	31
4.2.3 Test Procedures.....	32
4.2.4 Deviation from Test Standard	32
4.2.5 Test Setup.....	32
4.2.6 EUT Operating Conditions.....	32
4.2.7 Test Results	33
4.3 6dB Bandwidth Measurement	35
4.3.1 Limits of 6dB Bandwidth Measurement	35
4.3.2 Test Setup.....	35
4.3.3 Test Instruments	35
4.3.4 Test Procedure	35
4.3.5 Deviation from Test Standard	35
4.3.6 EUT Operating Conditions.....	35
4.3.7 Test Result	36
4.4 Conducted Output Power Measurement.....	38
4.4.1 Limits of Conducted Output Power Measurement	38
4.4.2 Test Setup.....	38
4.4.3 Test Instruments	38
4.4.4 Test Procedures.....	38
4.4.5 Deviation from Test Standard	38
4.4.6 EUT Operating Conditions.....	38
4.4.7 Test Results	39
4.5 Power Spectral Density Measurement.....	40
4.5.1 Limits of Power Spectral Density Measurement	40
4.5.2 Test Setup.....	40
4.5.3 Test Instruments	40
4.5.4 Test Procedure	40
4.5.5 Deviation from Test Standard	40



4.5.6 EUT Operating Condition	40
4.5.7 Test Results	41
4.6 Conducted Out of Band Emission Measurement.....	44
4.6.1 Limits of Conducted Out of Band Emission Measurement	44
4.6.2 Test Setup.....	44
4.6.3 Test Instruments	44
4.6.4 Test Procedure	44
4.6.5 Deviation from Test Standard	44
4.6.6 EUT Operating Condition	44
4.6.7 Test Results	44
5 Pictures of Test Arrangements.....	53
Appendix – Information on the Testing Laboratories	54



A D T

Release Control Record

Issue No.	Description	Date Issued
RF150825C34	Original release.	Nov. 05, 2015

1 Certificate of Conformity

Product: 802.11n/ac Unified Wireless Outdoor Access Point

Brand: D-Link

Test Model: DWL-8710AP

Sample Status: Engineering sample

Applicant: D-Link Corporation

Test Date: Sep. 25 ~ Oct. 29, 2015

Standards: 47 CFR FCC Part 15, Subpart C (Section 15.247)
ANSI C63.10:2013

The above equipment has been tested by **Bureau Veritas Consumer Products Services (H.K.) Ltd., Taoyuan Branch**, and found compliance with the requirement of the above standards. The test record, data evaluation & Equipment Under Test (EUT) configurations represented herein are true and accurate accounts of the measurements of the sample's EMC characteristics under the conditions specified in this report.

Prepared by :



, Date:

Nov. 05, 2015

Suntee Liu / Specialist

Approved by :



, Date:

Nov. 05, 2015

Ken Liu / Senior Manager

2 Summary of Test Results

47 CFR FCC Part 15, Subpart C (Section 15.247)			
FCC Clause	Test Item	Result	Remarks
15.207	AC Power Conducted Emission	PASS	Meet the requirement of limit. Minimum passing margin is -2.53dB at 0.43116MHz.
15.205 / 15.209 / 15.247(d)	Radiated Emissions and Band Edge Measurement	PASS	Meet the requirement of limit. Minimum passing margin is -1.2dB at 2390.00MHz.
15.247(d)	Antenna Port Emission	PASS	Meet the requirement of limit.
15.247(a)(2)	6dB bandwidth	PASS	Meet the requirement of limit.
15.247(b)	Conducted power	PASS	Meet the requirement of limit.
15.247(e)	Power Spectral Density	PASS	Meet the requirement of limit.
15.203	Antenna Requirement	PASS	Antenna connector is N Plug. (The device is professionally installed)

2.1 Measurement Uncertainty

Where relevant, the following measurement uncertainty levels have been estimated for tests performed on the EUT as specified in CISPR 16-4-2:

Measurement	Frequency	Expanded Uncertainty (k=2) (±)
Conducted Emissions at mains ports	150kHz ~ 30MHz	2.44 dB
Radiated Emissions up to 1 GHz	30MHz ~ 200MHz	3.86 dB
	200MHz ~ 1000MHz	3.87 dB
Radiated Emissions above 1 GHz	1GHz ~ 18GHz	2.29 dB
	18GHz ~ 40GHz	2.29 dB

2.2 Modification Record

There were no modifications required for compliance.

3 General Information

3.1 General Description of EUT

Product	802.11n/ac Unified Wireless Outdoor Access Point
Brand	D-Link
Test Model	DWL-8710AP
Sample Status	Engineering sample
Power Supply Rating	54Vdc (POE)
Modulation Type	CCK, DQPSK, DBPSK for DSSS 64QAM, 16QAM, QPSK, BPSK for OFDM
Modulation Technology	DSSS, OFDM
Transfer Rate	802.11b: 11/5.5/2/1Mbps 802.11g: 54/48/36/24/18/12/9/6Mbps 802.11n: up to 300Mbps
Operating Frequency	2412 ~ 2462MHz
Number of Channel	11 for 802.11b, 802.11g, 802.11n (HT20) 7 for 802.11n (HT40)
Output Power	746.74mW
Antenna Type	Dipole antenna with 4.92dBi gain
Antenna Connector	N Plug (The device is professionally installed)
Accessory Device	POE, POE's adapter
Cable Supplied	1.75m non-shielded ground cable

Note:

1. The EUT incorporates a MIMO function. Physically, the EUT provides 2 completed transmitters and 2 receivers.

Modulation Mode	TX Function
802.11b	2TX
802.11g	2TX
802.11n (HT20)	2TX
802.11n (HT40)	2TX

2. The EUT uses following POE.

POE	
Brand	D-Link
Model	DPE-301GI
Rating	54Vdc, 0.6A
POE's adapter	
Brand	Gospell Digital Technology Co., Ltd.
Model	G0753-540-060
Input Power	100-240Vac, 0.75A MAX, 50/60Hz
Output Power	54Vdc, 0.6A
Power Line	1.45m DC cable without core attached on adapter

3.2 Description of Test Modes

11 channels are provided for 802.11b, 802.11g and 802.11n (HT20):

Channel	Frequency	Channel	Frequency
1	2412MHz	7	2442MHz
2	2417MHz	8	2447MHz
3	2422MHz	9	2452MHz
4	2427MHz	10	2457MHz
5	2432MHz	11	2462MHz
6	2437MHz		

7 channels are provided for 802.11n (HT40):

Channel	Frequency	Channel	Frequency
3	2422MHz	7	2442MHz
4	2427MHz	8	2447MHz
5	2432MHz	9	2452MHz
6	2437MHz		

3.2.1 Test Mode Applicability and Tested Channel Detail

EUT Configure Mode	Applicable to				Description
	RE \geq 1G	RE<1G	PLC	APCM	
-	√	√	√	√	-

Where RE \geq 1G: Radiated Emission above 1GHz & Bandedge Measurement
 RE<1G: Radiated Emission below 1GHz
 PLC: Power Line Conducted Emission
 APCM: Antenna Port Conducted Measurement

Note: The EUT had been pre-tested on the positioned of each 3 axis. The worst case was found when positioned on **Z-plane**.

Radiated Emission Test (Above 1GHz):

- Pre-Scan has been conducted to determine the worst-case mode from all possible combinations between available modulations, data rates and antenna ports (if EUT with antenna diversity architecture).
- Following channel(s) was (were) selected for the final test as listed below.

EUT Configure Mode	Mode	Available Channel	Tested Channel	Modulation Technology	Modulation Type	Date Rate (Mbps)
-	802.11b	1 to 11	1, 6, 11	DSSS	DBPSK	1.0
-	802.11g	1 to 11	1, 6, 11	OFDM	BPSK	6.0
-	802.11n (HT20)	1 to 11	1, 6, 11	OFDM	BPSK	7.2
-	802.11n (HT40)	3 to 9	3, 6, 9	OFDM	BPSK	15.0

Radiated Emission Test (Below 1GHz):

- Pre-Scan has been conducted to determine the worst-case mode from all possible combinations between available modulations, data rates and antenna ports (if EUT with antenna diversity architecture).
- Following channel(s) was (were) selected for the final test as listed below.

EUT Configure Mode	Mode	Available Channel	Tested Channel	Modulation Technology	Modulation Type	Date Rate (Mbps)
-	802.11b	1 to 11	1	DSSS	DBPSK	1.0

Power Line Conducted Emission Test:

- Pre-Scan has been conducted to determine the worst-case mode from all possible combinations between available modulations, data rates and antenna ports (if EUT with antenna diversity architecture).
- Following channel(s) was (were) selected for the final test as listed below.

EUT Configure Mode	Mode	Available Channel	Tested Channel	Modulation Technology	Modulation Type	Date Rate (Mbps)
-	802.11b	1 to 11	1	DSSS	DBPSK	1.0

Antenna Port Conducted Measurement:

- This item includes all test value of each mode, but only includes spectrum plot of worst value of each mode.
- Pre-Scan has been conducted to determine the worst-case mode from all possible combinations between available modulations, data rates and antenna ports (if EUT with antenna diversity architecture).
- Following channel(s) was (were) selected for the final test as listed below.

EUT Configure Mode	Mode	Available Channel	Tested Channel	Modulation Technology	Modulation Type	Date Rate (Mbps)
-	802.11b	1 to 11	1, 6, 11	DSSS	DBPSK	1.0
-	802.11g	1 to 11	1, 6, 11	OFDM	BPSK	6.0
-	802.11n (HT20)	1 to 11	1, 6, 11	OFDM	BPSK	7.2
-	802.11n (HT40)	3 to 9	3, 6, 9	OFDM	BPSK	15.0

Test Condition:

Applicable to	Environmental Conditions	Input Power	Tested by
RE \geq 1G	23 deg. C, 65% RH	120Vac, 60Hz	Jones Chang
RE $<$ 1G	18 deg. C, 70% RH	120Vac, 60Hz	Nick Hsu
PLC	18 deg. C, 70% RH	120Vac, 60Hz	Nick Hsu
APCM	25 deg. C, 60% RH	120Vac, 60Hz	Ted Chang

3.3 Duty Cycle of Test Signal

802.11b, 802.11n (HT20): Duty cycle of test signal is $\geq 98\%$, duty factor is not required.

802.11g, 802.11n (HT40): Duty cycle of test signal is $< 98\%$, duty factor shall be considered.

802.11b: Duty cycle = 100%

802.11g: Duty cycle = $2.052/2.1 = 0.977$, Duty factor = $10 * \log(1/0.977) = 0.10$

802.11n (HT20): Duty cycle = $1.912/1.949 = 0.981$

802.11n (HT40): Duty cycle = $0.929/0.972 = 0.956$, Duty factor = $10 * \log(1/0.956) = 0.20$

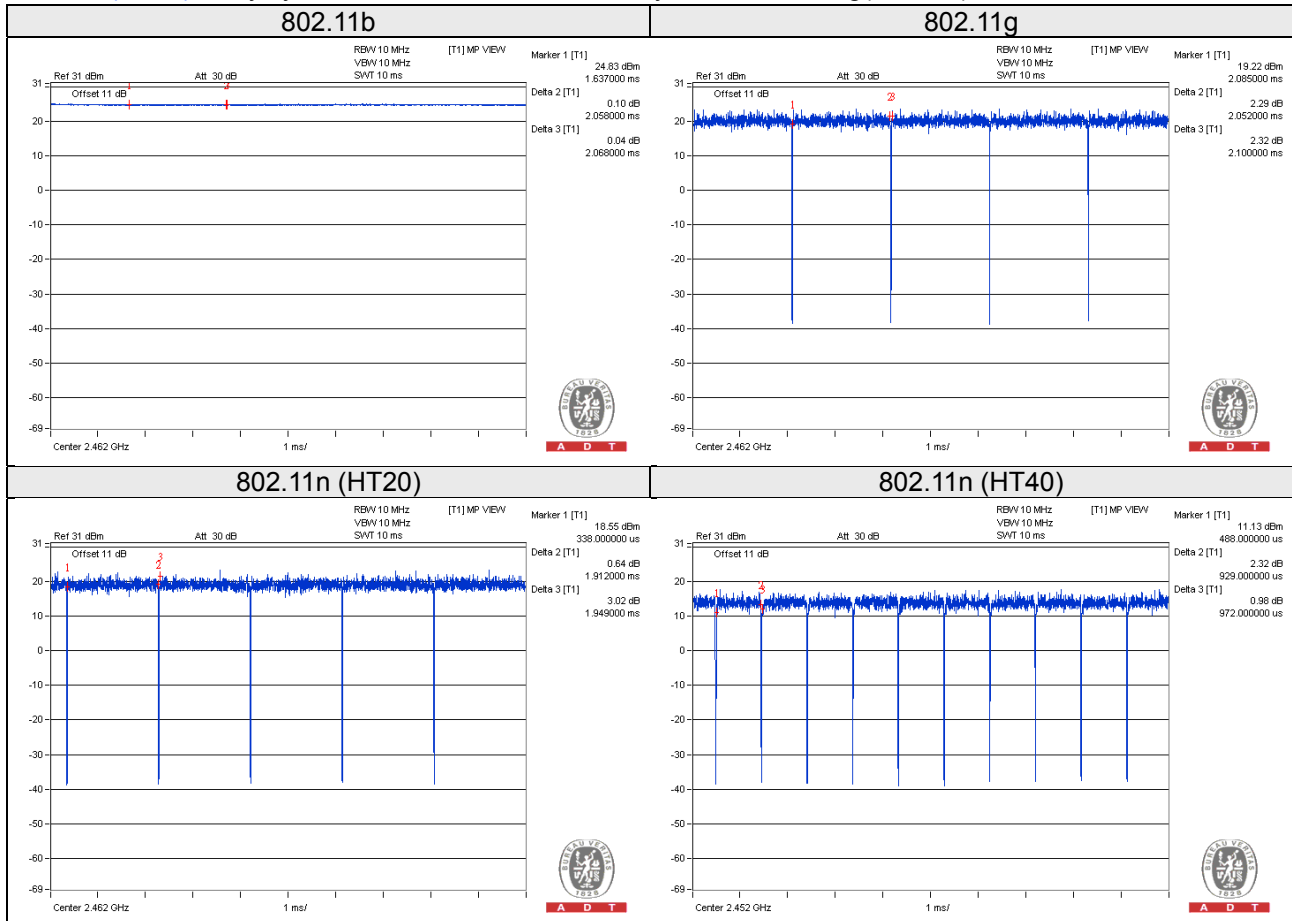

3.4 Description of Support Units

The EUT has been tested as an independent unit together with other necessary accessories or support units. The following support units or accessories were used to form a representative test configuration during the tests.

ID	Product	Brand	Model No.	Serial No.	FCC ID	Remarks
A.	Load	NA	NA	NA	NA	-
B.	Notebook	DELL	E5410	1HC2XM1	FCC DoC Approved	-

Note:

1. All power cords of the above support units are non-shielded (1.8m).
2. Item B acted as a communication partner to transfer data.

ID	Descriptions	Qty.	Length (m)	Shielding (Yes/No)	Cores (Qty.)	Remarks
1.	RJ45	1	1.8	N	0	-
2.	RJ45	1	1.8	N	0	-
3.	RJ45	1	5	N	0	-
4.	Ground	1	1.75	N	0	Accessory of EUT

3.4.1 Configuration of System under Test

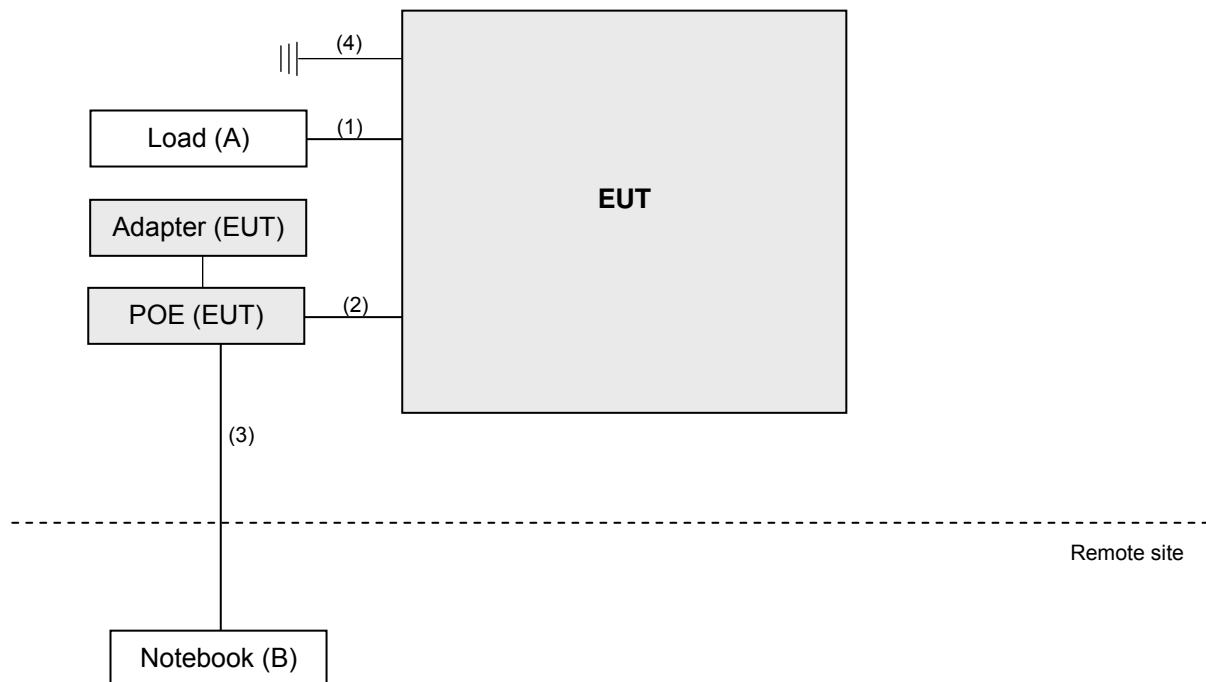

3.5 General Description of Applied Standards

The EUT is a RF Product. According to the specification of the EUT declared by the manufacturer, it must comply with the requirements of the following standards:

FCC Part 15, Subpart C (15.247)

558074 D01 DTS Meas Guidance v03r03

662911 D01 Multiple Transmitter Output v02r01

ANSI C63.10-2013

All test items have been performed and recorded as per the above standards.

NOTE: The EUT has been verified to comply with the requirements of FCC Part 15, Subpart B, Class B (DoC).
The test report has been issued separately.

4 Test Types and Results

4.1 Radiated Emission and Bandedge Measurement

4.1.1 Limits of Radiated Emission and Bandedge Measurement

Radiated emissions which fall in the restricted bands must comply with the radiated emission limits specified as below table. Other emissions shall be at least 30dB below the highest level of the desired power:

Frequencies (MHz)	Field Strength (microvolts/meter)	Measurement Distance (meters)
0.009 ~ 0.490	2400/F(kHz)	300
0.490 ~ 1.705	24000/F(kHz)	30
1.705 ~ 30.0	30	30
30 ~ 88	100	3
88 ~ 216	150	3
216 ~ 960	200	3
Above 960	500	3

NOTE:

1. The lower limit shall apply at the transition frequencies.
2. Emission level (dBuV/m) = 20 log Emission level (uV/m).
3. For frequencies above 1000MHz, the field strength limits are based on average detector, however, the peak field strength of any emission shall not exceed the maximum permitted average limits, specified above by more than 30dB under any condition of modulation.

4.1.2 Test Instruments

Description & Manufacturer	Model No.	Serial No.	Cal. Date	Cal. Due
Test Receiver ROHDE & SCHWARZ	ESIB7	100187	Apr. 10, 2015	Apr. 09, 2016
Spectrum Analyzer ROHDE & SCHWARZ	FSP40	100040	Jul. 08, 2015	Jul. 07, 2016
BILOG Antenna SCHWARZBECK	VULB9168	9168-160	Feb. 05, 2015	Feb. 04, 2016
HORN Antenna SCHWARZBECK	9120D	209	Feb. 09, 2015	Feb. 08, 2016
HORN Antenna SCHWARZBECK	BBHA 9170	BBHA9170241	Feb. 09, 2015	Feb. 08, 2016
Loop Antenna R&S	HFH2-Z2	100070	Mar. 06, 2014	Mar. 05, 2016
Preamplifier Agilent	8447D	2944A10738	Oct. 18, 2014	Oct. 17, 2015
			Oct. 18, 2015	Oct. 17, 2016
Preamplifier Agilent	8449B	3008A01964	Aug. 22, 2015	Aug. 21, 2016
RF signal cable HUBER+SUHNER	SUCOFLEX 104	Cable-CH3-03 (214378)	Aug. 22, 2015	Aug. 21, 2016
RF signal cable HUBER+SUHNER	SUCOFLEX 106	Cable-CH3-03 (309224+12738)	Aug. 22, 2015	Aug. 21, 2016
Software BV ADT	ADT_Radiated_ V7.6.15.9.4	NA	NA	NA
Antenna Tower inn-co GmbH	MA 4000	013303	NA	NA
Antenna Tower Controller BV ADT	AT100	AT93021702	NA	NA
Turn Table BV ADT	TT100	TT93021702	NA	NA
Turn Table Controller BV ADT	SC100	SC93021702	NA	NA
High Speed Peak Power Meter	ML2495A	0824011	Jul. 09, 2015	Jul. 08, 2016
Power Sensor	MA2411B	0738171	Jul. 09, 2015	Jul. 08, 2016

- Note:
1. The calibration interval of the above test instruments is 12 months and the calibrations are traceable to NML/ROC and NIST/USA.
 2. The calibration interval of the loop antenna is 24 months and the calibrations are traceable to NML/ROC and NIST/USA.
 2. The test was performed in HwaYa Chamber 3.
 3. The horn antenna and preamplifier (model: 8449B) are used only for the measurement of emission frequency above 1GHz if tested.
 4. The FCC Site Registration No. is 988962.
 5. The IC Site Registration No. is IC 7450F-3.

4.1.3 Test Procedures

- a. The EUT was placed on the top of a rotating table 0.8 meters (for below 1GHz) / 1.5 meters (for above 1GHz) above the ground at 3 meter chamber room for test. The table was rotated 360 degrees to determine the position of the highest radiation.
- b. The EUT was set 3 meters away from the interference-receiving antenna, which was mounted on the top of a variable-height antenna tower.
- c. The height of antenna is varied from one meter to four meters above the ground to determine the maximum value of the field strength. Both horizontal and vertical polarizations of the antenna are set to make the measurement.
- d. For each suspected emission, the EUT was arranged to its worst case and then the antenna was tuned to heights from 1 meter to 4 meters and the rotatable table was turned from 0 degrees to 360 degrees to find the maximum reading.
- e. The test-receiver system was set to quasi-peak detect function and specified bandwidth with maximum hold mode when the test frequency is below 1 GHz.
- f. The test-receiver system was set to peak and average detect function and specified bandwidth with maximum hold mode when the test frequency is above 1 GHz. If the peak reading value also meets average limit, measurement with the average detector is unnecessary.

Note:

1. The resolution bandwidth and video bandwidth of test receiver/spectrum analyzer is 120kHz for Quasi-peak detection (QP) at frequency below 1GHz.
2. The resolution bandwidth of test receiver/spectrum analyzer is 1 MHz and the video bandwidth is 3 MHz for Peak detection (PK) at frequency above 1GHz.
3. The resolution bandwidth of test receiver/spectrum analyzer is 1MHz and the video bandwidth is 3MHz for RMS Average (Duty cycle < 98%) for Average detection (AV) at frequency above 1GHz, then the measurement results was added to a correction factor ($10 \log(1/\text{duty cycle})$).
4. The resolution bandwidth of test receiver/spectrum analyzer is 1MHz and the video bandwidth is 10Hz (Duty cycle $\geq 98\%$) for Average detection (AV) at frequency above 1GHz.
5. All modes of operation were investigated and the worst-case emissions are reported.

4.1.4 Deviation from Test Standard

No deviation.

4.1.5 Test Set Up

<Frequency Range 30MHz~1GHz>

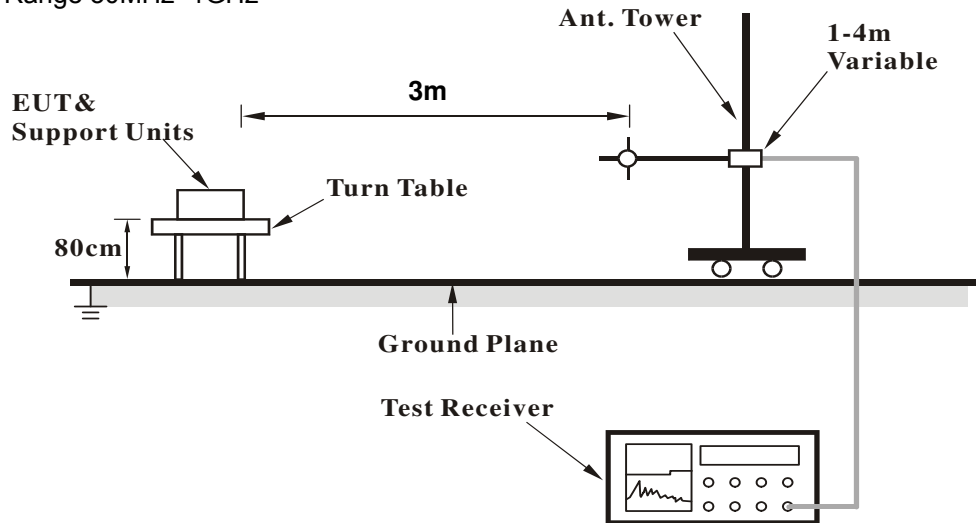

<Frequency Range above 1GHz>

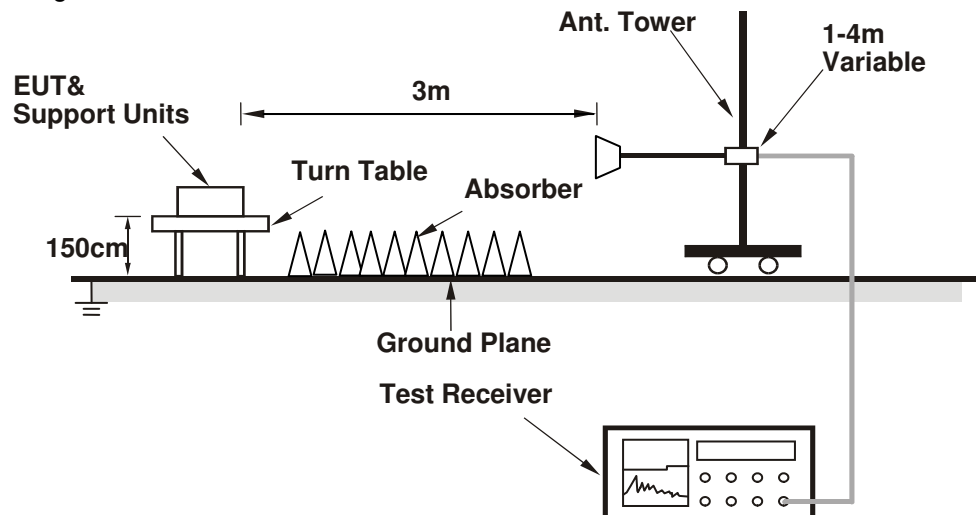

For the actual test configuration, please refer to the attached file (Test Setup Photo).

4.1.6 EUT Operating Conditions

- a. Placed the EUT on the testing table.
- b. Prepared a notebook to act as a communication partner and placed it outside of testing area.
- c. The communication partner connected with EUT via a RJ45 cable and ran a test program (provided by manufacturer) to enable EUT under transmission condition continuously at specific channel frequency.
- d. The communication partner sent data to EUT by command "PING".
- e. The necessary accessories enable the system in full functions.

4.1.7 Test Results

Above 1GHz Data :

802.11b

CHANNEL	TX Channel 1	DETECTOR FUNCTION	Peak (PK)
FREQUENCY RANGE	1GHz ~ 25GHz		Average (AV)

ANTENNA POLARITY & TEST DISTANCE: HORIZONTAL AT 3 M

NO.	FREQ. (MHz)	EMISSION LEVEL (dBuV/m)	LIMIT (dBuV/m)	MARGIN (dB)	ANTENNA HEIGHT (m)	TABLE ANGLE (Degree)	RAW VALUE (dBuV)	CORRECTION FACTOR (dB/m)
1	2390.00	57.0 PK	74.0	-17.0	1.00 H	218	24.50	32.50
2	2390.00	45.1 AV	54.0	-8.9	1.00 H	218	12.60	32.50
3	*2412.00	108.7 PK			1.00 H	134	76.10	32.60
4	*2412.00	105.0 AV			1.00 H	134	72.40	32.60
5	2492.00	58.3 PK	74.0	-15.7	1.00 H	120	25.60	32.70
6	2492.00	46.6 AV	54.0	-7.4	1.00 H	120	13.90	32.70
7	4824.00	49.6 PK	74.0	-24.4	1.30 H	156	43.50	6.10
8	4824.00	36.6 AV	54.0	-17.4	1.30 H	156	30.50	6.10

ANTENNA POLARITY & TEST DISTANCE: VERTICAL AT 3 M

NO.	FREQ. (MHz)	EMISSION LEVEL (dBuV/m)	LIMIT (dBuV/m)	MARGIN (dB)	ANTENNA HEIGHT (m)	TABLE ANGLE (Degree)	RAW VALUE (dBuV)	CORRECTION FACTOR (dB/m)
1	2387.00	62.7 PK	74.0	-11.3	1.71 V	347	30.20	32.50
2	2387.00	52.1 AV	54.0	-1.9	1.71 V	347	19.60	32.50
3	*2412.00	120.5 PK			1.86 V	3	87.90	32.60
4	*2412.00	116.6 AV			1.86 V	3	84.00	32.60
5	2492.00	61.7 PK	74.0	-12.3	1.76 V	358	29.00	32.70
6	2492.00	51.6 AV	54.0	-2.4	1.76 V	358	18.90	32.70
7	4824.00	48.9 PK	74.0	-25.1	1.60 V	123	42.80	6.10
8	4824.00	36.7 AV	54.0	-17.3	1.60 V	123	30.60	6.10

REMARKS:

1. Emission Level(dBuV/m) = Raw Value(dBuV) + Correction Factor(dB/m)
2. Correction Factor(dB/m) = Antenna Factor(dB/m) + Cable Factor(dB)
3. The other emission levels were very low against the limit.
4. Margin value = Emission Level – Limit value
5. " * ": Fundamental frequency.



CHANNEL	TX Channel 6	DETECTOR FUNCTION	Peak (PK)
FREQUENCY RANGE	1GHz ~ 25GHz		Average (AV)

ANTENNA POLARITY & TEST DISTANCE: HORIZONTAL AT 3 M

NO.	FREQ. (MHz)	EMISSION LEVEL (dBuV/m)	LIMIT (dBuV/m)	MARGIN (dB)	ANTENNA HEIGHT (m)	TABLE ANGLE (Degree)	RAW VALUE (dBuV)	CORRECTION FACTOR (dB/m)
1	*2437.00	111.4 PK			1.52 H	124	78.70	32.70
2	*2437.00	107.8 AV			1.52 H	124	75.10	32.70
3	2483.50	56.3 PK	74.0	-17.7	1.50 H	134	23.60	32.70
4	2483.50	45.8 AV	54.0	-8.2	1.50 H	134	13.10	32.70
5	4874.00	50.1 PK	74.0	-23.9	1.49 H	225	43.90	6.20
6	4874.00	37.0 AV	54.0	-17.0	1.49 H	225	30.80	6.20
7	7311.00	50.2 PK	74.0	-23.8	1.23 H	297	37.60	12.60
8	7311.00	43.4 AV	54.0	-10.6	1.23 H	297	30.80	12.60

ANTENNA POLARITY & TEST DISTANCE: VERTICAL AT 3 M

NO.	FREQ. (MHz)	EMISSION LEVEL (dBuV/m)	LIMIT (dBuV/m)	MARGIN (dB)	ANTENNA HEIGHT (m)	TABLE ANGLE (Degree)	RAW VALUE (dBuV)	CORRECTION FACTOR (dB/m)
1	*2437.00	122.0 PK			1.83 V	357	89.30	32.70
2	*2437.00	118.1 AV			1.83 V	357	85.40	32.70
3	2483.50	63.4 PK	74.0	-10.6	1.79 V	4	30.70	32.70
4	2483.50	52.1 AV	54.0	-1.9	1.79 V	4	19.40	32.70
5	4874.00	52.0 PK	74.0	-22.0	1.80 V	72	45.80	6.20
6	4874.00	38.9 AV	54.0	-15.1	1.80 V	72	32.70	6.20
7	7311.00	62.6 PK	74.0	-11.4	1.66 V	348	50.00	12.60
8	7311.00	51.1 AV	54.0	-2.9	1.66 V	348	38.50	12.60

REMARKS:

1. Emission Level(dBuV/m) = Raw Value(dBuV) + Correction Factor(dB/m)
2. Correction Factor(dB/m) = Antenna Factor(dB/m) + Cable Factor(dB)
3. The other emission levels were very low against the limit.
4. Margin value = Emission Level – Limit value
5. " * ": Fundamental frequency.

CHANNEL	TX Channel 11	DETECTOR FUNCTION	Peak (PK)
FREQUENCY RANGE	1GHz ~ 25GHz		Average (AV)

ANTENNA POLARITY & TEST DISTANCE: HORIZONTAL AT 3 M

NO.	FREQ. (MHz)	EMISSION LEVEL (dBuV/m)	LIMIT (dBuV/m)	MARGIN (dB)	ANTENNA HEIGHT (m)	TABLE ANGLE (Degree)	RAW VALUE (dBuV)	CORRECTION FACTOR (dB/m)
1	*2462.00	106.9 PK			1.50 H	128	74.30	32.60
2	*2462.00	103.1 AV			1.50 H	128	70.50	32.60
3	2483.50	57.3 PK	74.0	-16.7	1.50 H	128	24.60	32.70
4	2483.50	45.7 AV	54.0	-8.3	1.50 H	128	13.00	32.70
5	4924.00	48.7 PK	74.0	-25.3	1.39 H	197	42.40	6.30
6	4924.00	35.7 AV	54.0	-18.3	1.39 H	197	29.40	6.30

ANTENNA POLARITY & TEST DISTANCE: VERTICAL AT 3 M

NO.	FREQ. (MHz)	EMISSION LEVEL (dBuV/m)	LIMIT (dBuV/m)	MARGIN (dB)	ANTENNA HEIGHT (m)	TABLE ANGLE (Degree)	RAW VALUE (dBuV)	CORRECTION FACTOR (dB/m)
1	*2462.00	118.9 PK			1.82 V	359	86.30	32.60
2	*2462.00	115.3 AV			1.82 V	359	82.70	32.60
3	2483.50	63.0 PK	74.0	-11.0	1.80 V	355	30.30	32.70
4	2483.50	52.7 AV	54.0	-1.3	1.80 V	355	20.00	32.70
5	4924.00	49.0 PK	74.0	-25.0	1.62 V	229	42.70	6.30
6	4924.00	35.9 AV	54.0	-18.1	1.62 V	229	29.60	6.30

REMARKS:

1. Emission Level(dBuV/m) = Raw Value(dBuV) + Correction Factor(dB/m)
2. Correction Factor(dB/m) = Antenna Factor(dB/m) + Cable Factor(dB)
3. The other emission levels were very low against the limit.
4. Margin value = Emission Level – Limit value
5. " * ": Fundamental frequency.

802.11g

CHANNEL	TX Channel 1	DETECTOR FUNCTION	Peak (PK)
FREQUENCY RANGE	1GHz ~ 25GHz		Average (AV)

ANTENNA POLARITY & TEST DISTANCE: HORIZONTAL AT 3 M								
NO.	FREQ. (MHz)	EMISSION LEVEL (dBuV/m)	LIMIT (dBuV/m)	MARGIN (dB)	ANTENNA HEIGHT (m)	TABLE ANGLE (Degree)	RAW VALUE (dBuV)	CORRECTION FACTOR (dB/m)
1	2390.00	68.0 PK	74.0	-6.0	1.42 H	118	35.50	32.50
2	2390.00	50.9 AV	54.0	-3.1	1.42 H	118	18.40	32.50
3	*2412.00	101.2 PK			1.43 H	119	68.60	32.60
4	*2412.00	91.5 AV			1.43 H	119	58.90	32.60
5	4824.00	50.2 PK	74.0	-23.8	1.21 H	248	44.10	6.10
6	4824.00	37.6 AV	54.0	-16.4	1.21 H	248	31.50	6.10

ANTENNA POLARITY & TEST DISTANCE: VERTICAL AT 3 M								
NO.	FREQ. (MHz)	EMISSION LEVEL (dBuV/m)	LIMIT (dBuV/m)	MARGIN (dB)	ANTENNA HEIGHT (m)	TABLE ANGLE (Degree)	RAW VALUE (dBuV)	CORRECTION FACTOR (dB/m)
1	2390.00	72.1 PK	74.0	-1.9	1.64 V	141	39.60	32.50
2	2390.00	52.3 AV	54.0	-1.7	1.64 V	141	19.80	32.50
3	*2412.00	115.7 PK			1.73 V	321	83.10	32.60
4	*2412.00	106.3 AV			1.73 V	321	73.70	32.60
5	4824.00	49.6 PK	74.0	-24.4	1.60 V	38	43.50	6.10
6	4824.00	36.9 AV	54.0	-17.1	1.60 V	38	30.80	6.10

REMARKS:

1. Emission Level(dBuV/m) = Raw Value(dBuV) + Correction Factor(dB/m)
2. Correction Factor(dB/m) = Antenna Factor(dB/m) + Cable Factor(dB)
3. The other emission levels were very low against the limit.
4. Margin value = Emission Level – Limit value
5. " * ": Fundamental frequency.

CHANNEL	TX Channel 6	DETECTOR FUNCTION	Peak (PK)
FREQUENCY RANGE	1GHz ~ 25GHz		Average (AV)

ANTENNA POLARITY & TEST DISTANCE: HORIZONTAL AT 3 M

NO.	FREQ. (MHz)	EMISSION LEVEL (dBuV/m)	LIMIT (dBuV/m)	MARGIN (dB)	ANTENNA HEIGHT (m)	TABLE ANGLE (Degree)	RAW VALUE (dBuV)	CORRECTION FACTOR (dB/m)
1	2390.00	59.2 PK	74.0	-14.8	1.26 H	222	26.70	32.50
2	2390.00	46.0 AV	54.0	-8.0	1.26 H	222	13.50	32.50
3	*2437.00	109.5 PK			2.11 H	207	76.80	32.70
4	*2437.00	100.1 AV			2.11 H	207	67.40	32.70
5	2483.50	58.1 PK	74.0	-15.9	1.22 H	353	25.40	32.70
6	2483.50	45.3 AV	54.0	-8.7	1.22 H	353	12.60	32.70
7	4874.00	51.2 PK	74.0	-22.8	1.41 H	149	45.00	6.20
8	4874.00	38.8 AV	54.0	-15.2	1.41 H	149	32.60	6.20

ANTENNA POLARITY & TEST DISTANCE: VERTICAL AT 3 M

NO.	FREQ. (MHz)	EMISSION LEVEL (dBuV/m)	LIMIT (dBuV/m)	MARGIN (dB)	ANTENNA HEIGHT (m)	TABLE ANGLE (Degree)	RAW VALUE (dBuV)	CORRECTION FACTOR (dB/m)
1	2390.00	68.0 PK	74.0	-6.0	1.84 V	28	35.50	32.50
2	2390.00	50.2 AV	54.0	-3.8	1.84 V	28	17.70	32.50
3	*2437.00	124.0 PK			1.83 V	324	91.30	32.70
4	*2437.00	113.9 AV			1.83 V	324	81.20	32.70
5	2483.50	67.7 PK	74.0	-6.3	1.60 V	19	35.00	32.70
6	2483.50	52.7 AV	54.0	-1.3	1.60 V	19	20.00	32.70
7	4874.00	52.2 PK	74.0	-21.8	1.59 V	203	46.00	6.20
8	4874.00	39.2 AV	54.0	-14.8	1.59 V	203	33.00	6.20

REMARKS:

1. Emission Level(dBuV/m) = Raw Value(dBuV) + Correction Factor(dB/m)
2. Correction Factor(dB/m) = Antenna Factor(dB/m) + Cable Factor(dB)
3. The other emission levels were very low against the limit.
4. Margin value = Emission Level – Limit value
5. " * ": Fundamental frequency.

CHANNEL	TX Channel 11	DETECTOR FUNCTION	Peak (PK)
FREQUENCY RANGE	1GHz ~ 25GHz		Average (AV)

ANTENNA POLARITY & TEST DISTANCE: HORIZONTAL AT 3 M

NO.	FREQ. (MHz)	EMISSION LEVEL (dBuV/m)	LIMIT (dBuV/m)	MARGIN (dB)	ANTENNA HEIGHT (m)	TABLE ANGLE (Degree)	RAW VALUE (dBuV)	CORRECTION FACTOR (dB/m)
1	*2462.00	104.4 PK			1.54 H	104	71.80	32.60
2	*2462.00	94.8 AV			1.54 H	104	62.20	32.60
3	2483.50	63.7 PK	74.0	-10.3	1.52 H	107	31.00	32.70
4	2483.50	48.6 AV	54.0	-5.4	1.52 H	107	15.90	32.70
5	4924.00	50.2 PK	74.0	-23.8	1.26 H	122	43.90	6.30
6	4924.00	37.3 AV	54.0	-16.7	1.26 H	122	31.00	6.30

ANTENNA POLARITY & TEST DISTANCE: VERTICAL AT 3 M

NO.	FREQ. (MHz)	EMISSION LEVEL (dBuV/m)	LIMIT (dBuV/m)	MARGIN (dB)	ANTENNA HEIGHT (m)	TABLE ANGLE (Degree)	RAW VALUE (dBuV)	CORRECTION FACTOR (dB/m)
1	*2462.00	113.8 PK			1.60 V	242	81.20	32.60
2	*2462.00	102.8 AV			1.60 V	242	70.20	32.60
3	2483.50	72.3 PK	74.0	-1.7	1.61 V	19	39.60	32.70
4	2483.50	52.6 AV	54.0	-1.4	1.61 V	19	19.90	32.70
5	4924.00	49.5 PK	74.0	-24.5	1.50 V	279	43.20	6.30
6	4924.00	36.7 AV	54.0	-17.3	1.50 V	279	30.40	6.30

REMARKS:

1. Emission Level(dBuV/m) = Raw Value(dBuV) + Correction Factor(dB/m)
2. Correction Factor(dB/m) = Antenna Factor(dB/m) + Cable Factor(dB)
3. The other emission levels were very low against the limit.
4. Margin value = Emission Level – Limit value
5. " * ": Fundamental frequency.

802.11n (HT20)

CHANNEL	TX Channel 1	DETECTOR FUNCTION	Peak (PK)
FREQUENCY RANGE	1GHz ~ 25GHz		Average (AV)

ANTENNA POLARITY & TEST DISTANCE: HORIZONTAL AT 3 M								
NO.	FREQ. (MHz)	EMISSION LEVEL (dBuV/m)	LIMIT (dBuV/m)	MARGIN (dB)	ANTENNA HEIGHT (m)	TABLE ANGLE (Degree)	RAW VALUE (dBuV)	CORRECTION FACTOR (dB/m)
1	2390.00	62.5 PK	74.0	-11.5	1.06 H	130	30.00	32.50
2	2390.00	45.9 AV	54.0	-8.1	1.06 H	130	13.40	32.50
3	*2412.00	102.7 PK			1.00 H	133	70.10	32.60
4	*2412.00	93.3 AV			1.00 H	133	60.70	32.60
5	4824.00	50.1 PK	74.0	-23.9	1.36 H	22	44.00	6.10
6	4824.00	37.8 AV	54.0	-16.2	1.36 H	22	31.70	6.10

ANTENNA POLARITY & TEST DISTANCE: VERTICAL AT 3 M								
NO.	FREQ. (MHz)	EMISSION LEVEL (dBuV/m)	LIMIT (dBuV/m)	MARGIN (dB)	ANTENNA HEIGHT (m)	TABLE ANGLE (Degree)	RAW VALUE (dBuV)	CORRECTION FACTOR (dB/m)
1	2390.00	71.5 PK	74.0	-2.5	1.56 V	125	39.00	32.50
2	2390.00	52.8 AV	54.0	-1.2	1.56 V	125	20.30	32.50
3	*2412.00	114.2 PK			1.81 V	347	81.60	32.60
4	*2412.00	104.3 AV			1.81 V	347	71.70	32.60
5	4824.00	49.8 PK	74.0	-24.2	1.71 V	264	43.70	6.10
6	4824.00	37.1 AV	54.0	-16.9	1.71 V	264	31.00	6.10

REMARKS:

1. Emission Level(dBuV/m) = Raw Value(dBuV) + Correction Factor(dB/m)
2. Correction Factor(dB/m) = Antenna Factor(dB/m) + Cable Factor(dB)
3. The other emission levels were very low against the limit.
4. Margin value = Emission Level – Limit value
5. " * ": Fundamental frequency.

CHANNEL	TX Channel 6	DETECTOR FUNCTION	Peak (PK)
FREQUENCY RANGE	1GHz ~ 25GHz		Average (AV)

ANTENNA POLARITY & TEST DISTANCE: HORIZONTAL AT 3 M

NO.	FREQ. (MHz)	EMISSION LEVEL (dBuV/m)	LIMIT (dBuV/m)	MARGIN (dB)	ANTENNA HEIGHT (m)	TABLE ANGLE (Degree)	RAW VALUE (dBuV)	CORRECTION FACTOR (dB/m)
1	2390.00	58.2 PK	74.0	-15.8	1.23 H	100	25.70	32.50
2	2390.00	46.1 AV	54.0	-7.9	1.23 H	100	13.60	32.50
3	*2437.00	110.6 PK			1.00 H	130	77.90	32.70
4	*2437.00	102.1 AV			1.00 H	130	69.40	32.70
5	2483.50	59.0 PK	74.0	-15.0	1.11 H	22	26.30	32.70
6	2483.50	47.1 AV	54.0	-6.9	1.11 H	22	14.40	32.70
7	4874.00	50.1 PK	74.0	-23.9	1.11 H	68	43.90	6.20
8	4874.00	37.9 AV	54.0	-16.1	1.11 H	68	31.70	6.20

ANTENNA POLARITY & TEST DISTANCE: VERTICAL AT 3 M

NO.	FREQ. (MHz)	EMISSION LEVEL (dBuV/m)	LIMIT (dBuV/m)	MARGIN (dB)	ANTENNA HEIGHT (m)	TABLE ANGLE (Degree)	RAW VALUE (dBuV)	CORRECTION FACTOR (dB/m)
1	2390.00	68.8 PK	74.0	-5.2	1.89 V	317	36.30	32.50
2	2390.00	50.8 AV	54.0	-3.2	1.89 V	317	18.30	32.50
3	*2437.00	121.3 PK			1.61 V	79	88.60	32.70
4	*2437.00	111.3 AV			1.61 V	79	78.60	32.70
5	2483.50	68.2 PK	74.0	-5.8	1.82 V	326	35.50	32.70
6	2483.50	52.1 AV	54.0	-1.9	1.82 V	326	19.40	32.70
7	4874.00	49.7 PK	74.0	-24.3	1.53 V	229	43.50	6.20
8	4874.00	36.4 AV	54.0	-17.6	1.53 V	229	30.20	6.20

REMARKS:

1. Emission Level(dBuV/m) = Raw Value(dBuV) + Correction Factor(dB/m)
2. Correction Factor(dB/m) = Antenna Factor(dB/m) + Cable Factor(dB)
3. The other emission levels were very low against the limit.
4. Margin value = Emission Level – Limit value
5. " * ": Fundamental frequency.



CHANNEL	TX Channel 11	DETECTOR FUNCTION	Peak (PK)
FREQUENCY RANGE	1GHz ~ 25GHz		Average (AV)

ANTENNA POLARITY & TEST DISTANCE: HORIZONTAL AT 3 M

NO.	FREQ. (MHz)	EMISSION LEVEL (dBuV/m)	LIMIT (dBuV/m)	MARGIN (dB)	ANTENNA HEIGHT (m)	TABLE ANGLE (Degree)	RAW VALUE (dBuV)	CORRECTION FACTOR (dB/m)
1	*2462.00	102.8 PK			1.11 H	132	70.20	32.60
2	*2462.00	93.5 AV			1.11 H	132	60.90	32.60
3	2483.50	59.9 PK	74.0	-14.1	1.15 H	130	27.20	32.70
4	2483.50	47.6 AV	54.0	-6.4	1.15 H	130	14.90	32.70
5	4924.00	48.5 PK	74.0	-25.5	1.23 H	358	42.20	6.30
6	4924.00	35.7 AV	54.0	-18.3	1.23 H	358	29.40	6.30

ANTENNA POLARITY & TEST DISTANCE: VERTICAL AT 3 M

NO.	FREQ. (MHz)	EMISSION LEVEL (dBuV/m)	LIMIT (dBuV/m)	MARGIN (dB)	ANTENNA HEIGHT (m)	TABLE ANGLE (Degree)	RAW VALUE (dBuV)	CORRECTION FACTOR (dB/m)
1	*2462.00	114.4 PK			1.66 V	12	81.80	32.60
2	*2462.00	104.8 AV			1.66 V	12	72.20	32.60
3	2483.50	71.0 PK	74.0	-3.0	1.70 V	15	38.30	32.70
4	2483.50	52.6 AV	54.0	-1.4	1.70 V	15	19.90	32.70
5	4924.00	49.0 PK	74.0	-25.0	1.43 V	81	42.70	6.30
6	4924.00	35.6 AV	54.0	-18.4	1.43 V	81	29.30	6.30

REMARKS:

1. Emission Level(dBuV/m) = Raw Value(dBuV) + Correction Factor(dB/m)
2. Correction Factor(dB/m) = Antenna Factor(dB/m) + Cable Factor(dB)
3. The other emission levels were very low against the limit.
4. Margin value = Emission Level – Limit value
5. " * ": Fundamental frequency.

802.11n (HT40)

CHANNEL	TX Channel 3	DETECTOR FUNCTION	Peak (PK)
FREQUENCY RANGE	1GHz ~ 25GHz		Average (AV)

ANTENNA POLARITY & TEST DISTANCE: HORIZONTAL AT 3 M								
NO.	FREQ. (MHz)	EMISSION LEVEL (dBuV/m)	LIMIT (dBuV/m)	MARGIN (dB)	ANTENNA HEIGHT (m)	TABLE ANGLE (Degree)	RAW VALUE (dBuV)	CORRECTION FACTOR (dB/m)
1	2390.00	62.8 PK	74.0	-11.2	1.30 H	191	30.30	32.50
2	2390.00	47.1 AV	54.0	-6.9	1.30 H	191	14.60	32.50
3	*2422.00	100.2 PK			1.00 H	131	67.60	32.60
4	*2422.00	90.8 AV			1.00 H	131	58.20	32.60
5	4844.00	48.1 PK	74.0	-25.9	1.20 H	221	42.00	6.10
6	4844.00	35.3 AV	54.0	-18.7	1.20 H	221	29.20	6.10

ANTENNA POLARITY & TEST DISTANCE: VERTICAL AT 3 M								
NO.	FREQ. (MHz)	EMISSION LEVEL (dBuV/m)	LIMIT (dBuV/m)	MARGIN (dB)	ANTENNA HEIGHT (m)	TABLE ANGLE (Degree)	RAW VALUE (dBuV)	CORRECTION FACTOR (dB/m)
1	2390.00	66.9 PK	74.0	-7.1	1.70 V	341	34.40	32.50
2	2390.00	52.5 AV	54.0	-1.5	1.70 V	341	20.00	32.50
3	*2422.00	109.3 PK			1.72 V	344	76.70	32.60
4	*2422.00	100.2 AV			1.72 V	344	67.60	32.60
5	4844.00	48.6 PK	74.0	-25.4	1.62 V	284	42.50	6.10
6	4844.00	35.6 AV	54.0	-18.4	1.62 V	284	29.50	6.10

REMARKS:

1. Emission Level(dBuV/m) = Raw Value(dBuV) + Correction Factor(dB/m)
2. Correction Factor(dB/m) = Antenna Factor(dB/m) + Cable Factor(dB)
3. The other emission levels were very low against the limit.
4. Margin value = Emission Level – Limit value
5. " * ": Fundamental frequency.

CHANNEL	TX Channel 6	DETECTOR FUNCTION	Peak (PK)
FREQUENCY RANGE	1GHz ~ 25GHz		Average (AV)

ANTENNA POLARITY & TEST DISTANCE: HORIZONTAL AT 3 M

NO.	FREQ. (MHz)	EMISSION LEVEL (dBuV/m)	LIMIT (dBuV/m)	MARGIN (dB)	ANTENNA HEIGHT (m)	TABLE ANGLE (Degree)	RAW VALUE (dBuV)	CORRECTION FACTOR (dB/m)
1	2390.00	56.7 PK	74.0	-17.3	1.00 H	123	24.20	32.50
2	2390.00	45.0 AV	54.0	-9.0	1.00 H	123	12.50	32.50
3	*2437.00	102.3 PK			1.00 H	123	69.60	32.70
4	*2437.00	93.0 AV			1.00 H	123	60.30	32.70
5	2483.50	58.9 PK	74.0	-15.1	1.06 H	130	26.20	32.70
6	2483.50	46.1 AV	54.0	-7.9	1.06 H	130	13.40	32.70
7	4874.00	48.4 PK	74.0	-25.6	1.29 H	176	42.20	6.20
8	4874.00	35.4 AV	54.0	-18.6	1.29 H	176	29.20	6.20

ANTENNA POLARITY & TEST DISTANCE: VERTICAL AT 3 M

NO.	FREQ. (MHz)	EMISSION LEVEL (dBuV/m)	LIMIT (dBuV/m)	MARGIN (dB)	ANTENNA HEIGHT (m)	TABLE ANGLE (Degree)	RAW VALUE (dBuV)	CORRECTION FACTOR (dB/m)
1	2390.00	67.1 PK	74.0	-6.9	2.02 V	0	34.60	32.50
2	2390.00	50.3 AV	54.0	-3.7	2.02 V	0	17.80	32.50
3	*2437.00	113.2 PK			1.68 V	322	80.50	32.70
4	*2437.00	103.8 AV			1.68 V	322	71.10	32.70
5	2483.50	70.3 PK	74.0	-3.7	1.62 V	6	37.60	32.70
6	2483.50	52.6 AV	54.0	-1.4	1.62 V	6	19.90	32.70
7	4874.00	49.2 PK	74.0	-24.8	1.60 V	343	43.00	6.20
8	4874.00	36.0 AV	54.0	-18.0	1.60 V	343	29.80	6.20

REMARKS:

1. Emission Level(dBuV/m) = Raw Value(dBuV) + Correction Factor(dB/m)
2. Correction Factor(dB/m) = Antenna Factor(dB/m) + Cable Factor(dB)
3. The other emission levels were very low against the limit.
4. Margin value = Emission Level – Limit value
5. " * ": Fundamental frequency.

CHANNEL	TX Channel 9	DETECTOR FUNCTION	Peak (PK)
FREQUENCY RANGE	1GHz ~ 25GHz		Average (AV)

ANTENNA POLARITY & TEST DISTANCE: HORIZONTAL AT 3 M

NO.	FREQ. (MHz)	EMISSION LEVEL (dBuV/m)	LIMIT (dBuV/m)	MARGIN (dB)	ANTENNA HEIGHT (m)	TABLE ANGLE (Degree)	RAW VALUE (dBuV)	CORRECTION FACTOR (dB/m)
1	*2452.00	98.0 PK			1.00 H	132	65.30	32.70
2	*2452.00	89.4 AV			1.00 H	132	56.70	32.70
3	2483.50	58.8 PK	74.0	-15.2	1.03 H	144	26.10	32.70
4	2483.50	46.3 AV	54.0	-7.7	1.03 H	144	13.60	32.70
5	4904.00	47.6 PK	74.0	-26.4	1.22 H	163	41.50	6.10
6	4904.00	34.6 AV	54.0	-19.4	1.22 H	163	28.50	6.10

ANTENNA POLARITY & TEST DISTANCE: VERTICAL AT 3 M

NO.	FREQ. (MHz)	EMISSION LEVEL (dBuV/m)	LIMIT (dBuV/m)	MARGIN (dB)	ANTENNA HEIGHT (m)	TABLE ANGLE (Degree)	RAW VALUE (dBuV)	CORRECTION FACTOR (dB/m)
1	*2452.00	109.2 PK			1.68 V	330	76.50	32.70
2	*2452.00	100.1 AV			1.68 V	330	67.40	32.70
3	2483.50	67.2 PK	74.0	-6.8	1.62 V	10	34.50	32.70
4	2483.50	52.4 AV	54.0	-1.6	1.62 V	10	19.70	32.70
5	4904.00	47.8 PK	74.0	-26.2	1.59 V	166	41.70	6.10
6	4904.00	34.8 AV	54.0	-19.2	1.59 V	166	28.70	6.10

REMARKS:

1. Emission Level(dBuV/m) = Raw Value(dBuV) + Correction Factor(dB/m)
2. Correction Factor(dB/m) = Antenna Factor(dB/m) + Cable Factor(dB)
3. The other emission levels were very low against the limit.
4. Margin value = Emission Level – Limit value
5. " * ": Fundamental frequency.

Below 1GHz Worst-Case Data: 802.11b

CHANNEL	TX Channel 1	DETECTOR FUNCTION	Quasi-Peak (QP)
FREQUENCY RANGE	9kHz ~ 1GHz		

ANTENNA POLARITY & TEST DISTANCE: HORIZONTAL AT 3 M								
NO.	FREQ. (MHz)	EMISSION LEVEL (dBuV/m)	LIMIT (dBuV/m)	MARGIN (dB)	ANTENNA HEIGHT (m)	TABLE ANGLE (Degree)	RAW VALUE (dBuV)	CORRECTION FACTOR (dB/m)
1	57.12	31.6 QP	40.0	-8.4	1.50 H	59	46.40	-14.80
2	97.95	33.4 QP	43.5	-10.1	1.99 H	252	52.70	-19.30
3	142.67	35.3 QP	43.5	-8.2	1.99 H	72	49.70	-14.40
4	183.50	34.7 QP	43.5	-8.8	1.50 H	132	50.20	-15.50
5	202.94	35.1 QP	43.5	-8.4	1.50 H	39	51.90	-16.80
6	288.49	28.2 QP	46.0	-17.8	1.00 H	120	41.00	-12.80

ANTENNA POLARITY & TEST DISTANCE: VERTICAL AT 3 M								
NO.	FREQ. (MHz)	EMISSION LEVEL (dBuV/m)	LIMIT (dBuV/m)	MARGIN (dB)	ANTENNA HEIGHT (m)	TABLE ANGLE (Degree)	RAW VALUE (dBuV)	CORRECTION FACTOR (dB/m)
1	49.93	36.8 QP	40.0	-3.2	1.12 V	30	51.40	-14.60
2	62.95	35.2 QP	40.0	-4.8	1.00 V	124	50.60	-15.40
3	109.62	36.4 QP	43.5	-7.1	1.00 V	277	53.80	-17.40
4	148.50	33.4 QP	43.5	-10.1	1.00 V	296	47.40	-14.00
5	175.72	31.8 QP	43.5	-11.7	1.00 V	3	46.50	-14.70
6	202.94	32.7 QP	43.5	-10.8	1.00 V	183	49.50	-16.80

REMARKS:

1. Emission Level(dBuV/m) = Raw Value(dBuV) + Correction Factor(dB/m)
2. Correction Factor(dB/m) = Antenna Factor(dB/m) + Cable Factor(dB)
3. The other emission levels were very low against the limit.
4. Margin value = Emission Level – Limit value

4.2 Conducted Emission Measurement

4.2.1 Limits of Conducted Emission Measurement

Frequency (MHz)	Conducted Limit (dBuV)	
	Quasi-peak	Average
0.15 - 0.5	66 - 56	56 - 46
0.50 - 5.0	56	46
5.0 - 30.0	60	50

Note: 1. The lower limit shall apply at the transition frequencies.

2. The limit decreases in line with the logarithm of the frequency in the range of 0.15 to 0.50MHz.

4.2.2 Test Instruments

Description & Manufacturer	Model No.	Serial No.	Cal. Date	Cal. Due
Test Receiver ROHDE & SCHWARZ	ESCS 30	100288	Apr. 27, 2015	Apr. 26, 2016
RF signal cable (with 10dB PAD) Woken	5D-FB	Cable-cond2-01	Dec. 26, 2014	Dec. 25, 2015
LISN ROHDE & SCHWARZ (EUT)	ESH2-Z5	100100	Dec. 30, 2014	Dec. 29, 2015
LISN ROHDE & SCHWARZ (Peripheral)	ESH3-Z5	100312	Jul. 21, 2015	Jul. 20, 2016
Software ADT	BV ADT_Cond_ V7.3.7.3	NA	NA	NA

Note: 1. The calibration interval of the above test instruments is 12 months and the calibrations are traceable to NML/ROC and NIST/USA.

2. The test was performed in HwaYa Shielded Room 2.

3. The VCCI Site Registration No. is C-2047.

4.2.3 Test Procedures

- The EUT was placed 0.4 meters from the conducting wall of the shielded room with EUT being connected to the power mains through a line impedance stabilization network (LISN). Other support units were connected to the power mains through another LISN. The two LISNs provide 50 ohm/ 50uH of coupling impedance for the measuring instrument.
- Both lines of the power mains connected to the EUT were checked for maximum conducted interference.
- The frequency range from 150kHz to 30MHz was searched. Emission levels under (Limit - 20dB) were not recorded.

NOTE: The resolution bandwidth and video bandwidth of test receiver is 9kHz for quasi-peak detection (QP) and average detection (AV) at frequency 0.15MHz-30MHz.

4.2.4 Deviation from Test Standard

No deviation.

4.2.5 Test Setup

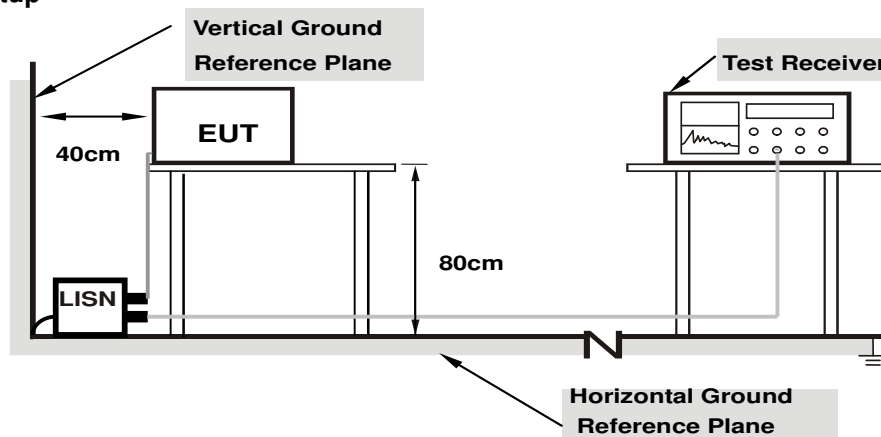

Note: 1.Support units were connected to second LISN.

For the actual test configuration, please refer to the attached file (Test Setup Photo).

4.2.6 EUT Operating Conditions

Same as 4.1.6.

4.2.7 Test Results

Phase	Line (L)	Detector Function	Quasi-Peak (QP) / Average (AV)
-------	----------	-------------------	--------------------------------

No	Freq. [MHz]	Corr. Factor (dB)	Reading Value [dB (uV)]		Emission Level [dB (uV)]		Limit [dB (uV)]		Margin (dB)	
			Q.P.	AV.	Q.P.	AV.	Q.P.	AV.	Q.P.	AV.
			1	0.15000	9.94	39.50	27.20	49.44	37.14	66.00
2	0.18125	9.94	39.02	28.72	48.96	38.66	64.43	54.43	-15.46	-15.76
3	0.43234	9.96	36.25	34.50	46.21	44.46	57.21	47.21	-11.00	-2.75
4	4.59766	10.29	28.23	21.09	38.52	31.38	56.00	46.00	-17.48	-14.62
5	5.55078	10.31	30.31	22.21	40.62	32.52	60.00	50.00	-19.38	-17.48
6	6.89453	10.35	32.50	26.52	42.85	36.87	60.00	50.00	-17.15	-13.13

REMARKS:

1. Q.P. and AV. are abbreviations of quasi-peak and average individually.
2. The emission levels of other frequencies were very low against the limit.
3. Margin value = Emission level - Limit value
4. Correction factor = Insertion loss + Cable loss
5. Emission Level = Correction Factor + Reading Value.

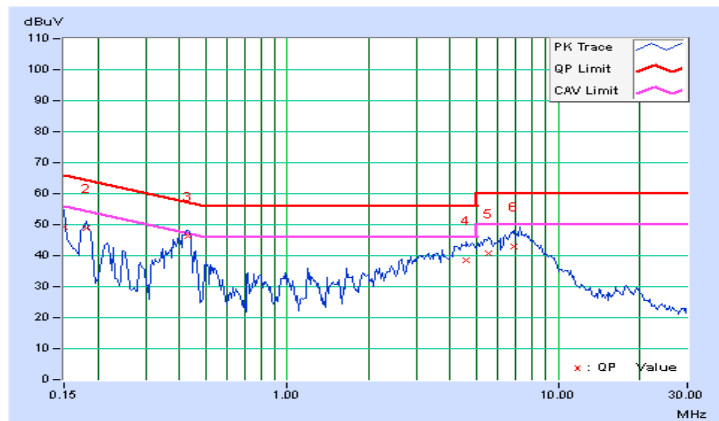

Phase	Neutral (N)	Detector Function	Quasi-Peak (QP) / Average (AV)
-------	-------------	-------------------	--------------------------------

No	Freq. [MHz]	Corr. Factor (dB)	Reading Value [dB (uV)]		Emission Level [dB (uV)]		Limit [dB (uV)]		Margin (dB)	
			Q.P.	AV.	Q.P.	AV.	Q.P.	AV.	Q.P.	AV.
			1	0.15000	9.95	40.08	27.00	50.03	36.95	66.00
2	0.17989	9.96	39.43	29.35	49.39	39.31	64.49	54.49	-15.10	-15.18
3	0.43116	10.00	36.41	34.70	46.41	44.70	57.23	47.23	-10.82	-2.53
4	0.97521	10.07	21.25	16.09	31.32	26.16	56.00	46.00	-24.68	-19.84
5	4.71875	10.33	29.48	22.01	39.81	32.34	56.00	46.00	-16.19	-13.66
6	7.52734	10.42	32.41	27.11	42.83	37.53	60.00	50.00	-17.17	-12.47

REMARKS:

1. Q.P. and AV. are abbreviations of quasi-peak and average individually.
2. The emission levels of other frequencies were very low against the limit.
3. Margin value = Emission level - Limit value
4. Correction factor = Insertion loss + Cable loss
5. Emission Level = Correction Factor + Reading Value.

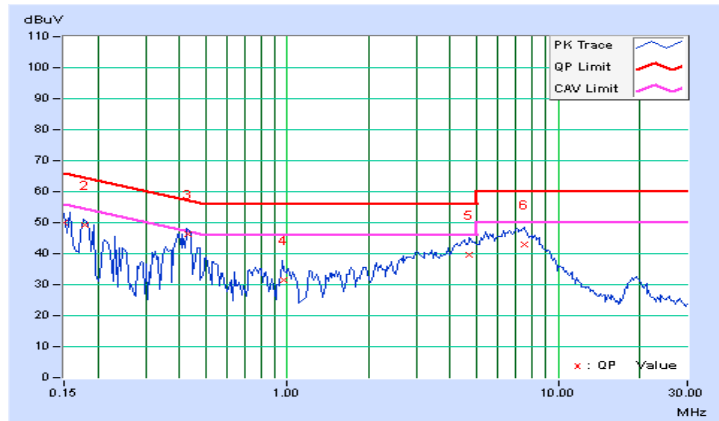

4.3 6dB Bandwidth Measurement

4.3.1 Limits of 6dB Bandwidth Measurement

The minimum of 6dB Bandwidth Measurement is 0.5 MHz.

4.3.2 Test Setup

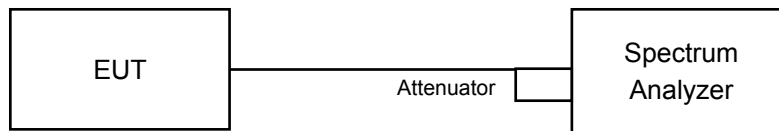

4.3.3 Test Instruments

Refer to section 4.1.2 to get information of above instrument.

4.3.4 Test Procedure

- Set resolution bandwidth (RBW) = 100kHz
- Set the video bandwidth (VBW) $\geq 3 \times$ RBW, Detector = Peak.
- Trace mode = max hold.
- Sweep = auto couple.
- Measure the maximum width of the emission that is constrained by the frequencies associated with the two amplitude points (upper and lower) that are attenuated by 6 dB relative to the maximum level measured in the fundamental emission

4.3.5 Deviation from Test Standard

No deviation.

4.3.6 EUT Operating Conditions

The software provided by client to enable the EUT under transmission condition continuously at lowest, middle and highest channel frequencies individually.

4.3.7 Test Result

802.11b

Channel	Frequency (MHz)	6dB Bandwidth (MHz)		Minimum Limit (MHz)	Pass / Fail
		CHAIN 0	CHAIN 1		
1	2412	9.07	9.12	0.5	Pass
6	2437	9.10	9.08	0.5	Pass
11	2462	8.57	9.09	0.5	Pass

802.11g

Channel	Frequency (MHz)	6dB Bandwidth (MHz)		Minimum Limit (MHz)	Pass / Fail
		CHAIN 0	CHAIN 1		
1	2412	16.43	16.45	0.5	Pass
6	2437	16.35	16.40	0.5	Pass
11	2462	16.40	16.44	0.5	Pass

802.11n (HT20)

Channel	Frequency (MHz)	6dB Bandwidth (MHz)		Minimum Limit (MHz)	Pass / Fail
		CHAIN 0	CHAIN 1		
1	2412	17.65	17.67	0.5	Pass
6	2437	17.21	17.67	0.5	Pass
11	2462	17.63	17.66	0.5	Pass

802.11n (HT40)

Channel	Frequency (MHz)	6dB Bandwidth (MHz)		Minimum Limit (MHz)	Pass / Fail
		CHAIN 0	CHAIN 1		
3	2422	36.24	36.41	0.5	Pass
6	2437	36.12	36.42	0.5	Pass
9	2452	36.37	36.45	0.5	Pass

Spectrum Plot of Worst Value

802.11b

802.11g

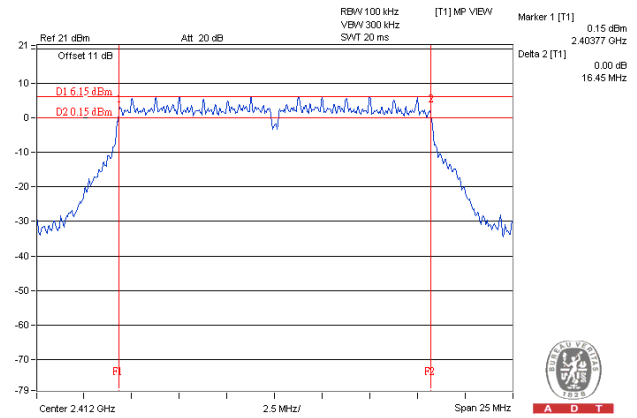
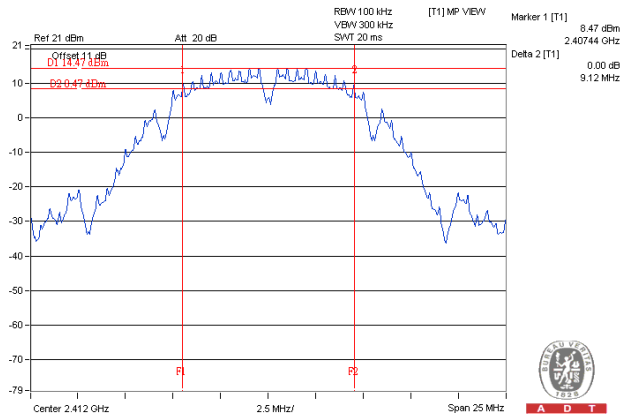

802.11n (HT20)

802.11n (HT40)

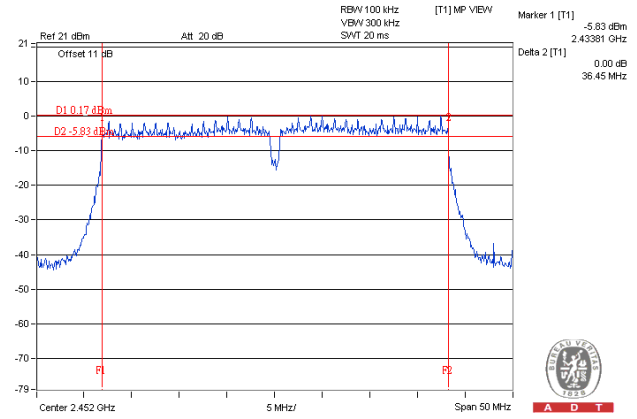
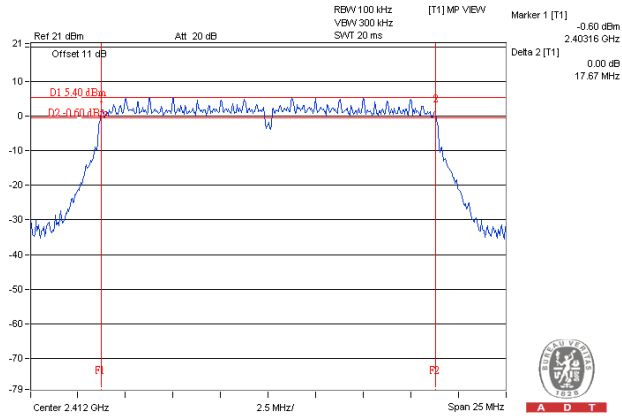

4.4 Conducted Output Power Measurement

4.4.1 Limits of Conducted Output Power Measurement

For systems using digital modulation in the 2400–2483.5 MHz bands: 1 Watt (30dBm)

Per KDB 662911 D01 Multiple Transmitter Output Method of conducted output power measurement on IEEE 802.11 devices,

Array Gain = 0 dB (i.e., no array gain) for $NANT \leq 4$;

Array Gain = 0 dB (i.e., no array gain) for channel widths ≥ 40 MHz for any NANT;

Array Gain = $5 \log(NANT/NSS)$ dB or 3 dB, whichever is less for 20-MHz channel widths with $NANT \geq 5$.

For power measurements on all other devices: Array Gain = $10 \log(NANT/NSS)$ dB.

4.4.2 Test Setup

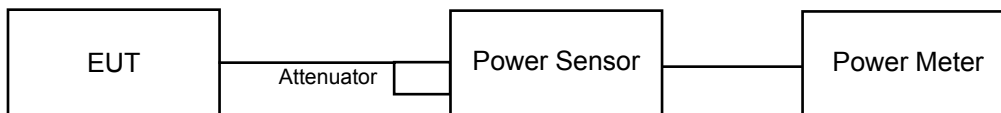

4.4.3 Test Instruments

Refer to section 4.1.2 to get information of above instrument.

4.4.4 Test Procedures

An average power sensor was used on the output port of the EUT. A power meter was used to read the response of the average power sensor. Record the power level.

4.4.5 Deviation from Test Standard

No deviation.

4.4.6 EUT Operating Conditions

Same as item 4.3.6.

4.4.7 Test Results

For Average Power

802.11b

Chan.	Freq. (MHz)	Average Power (dBm)		Total Power (mW)	Total Power (dBm)	Limit (dBm)	Pass / Fail
		Chain 0	Chain 1				
1	2412	23.84	23.63	472.778	26.75	30	Pass
6	2437	25.83	25.61	746.740	28.73	30	Pass
11	2462	22.37	22.01	331.439	25.20	30	Pass

802.11g

Chan.	Freq. (MHz)	Average Power (dBm)		Total Power (mW)	Total Power (dBm)	Limit (dBm)	Pass / Fail
		Chain 0	Chain 1				
1	2412	18.76	18.43	144.825	21.61	30	Pass
6	2437	24.45	24.14	538.030	27.31	30	Pass
11	2462	17.53	17.52	113.118	20.54	30	Pass

802.11n (HT20)

Chan.	Freq. (MHz)	Average Power (dBm)		Total Power (mW)	Total Power (dBm)	Limit (dBm)	Pass / Fail
		Chain 0	Chain 1				
1	2412	17.76	17.46	115.423	20.62	30	Pass
6	2437	24.24	23.79	504.793	27.03	30	Pass
11	2462	16.80	16.53	92.841	19.68	30	Pass

802.11n (HT40)

Chan.	Freq. (MHz)	Average Power (dBm)		Total Power (mW)	Total Power (dBm)	Limit (dBm)	Pass / Fail
		Chain 0	Chain 1				
3	2422	16.35	15.95	82.507	19.16	30	Pass
6	2437	18.59	18.40	141.460	21.51	30	Pass
9	2452	14.92	14.78	61.107	17.86	30	Pass

4.5 Power Spectral Density Measurement

4.5.1 Limits of Power Spectral Density Measurement

The Maximum of Power Spectral Density Measurement is 8dBm.

4.5.2 Test Setup

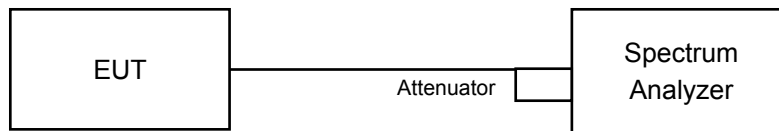

4.5.3 Test Instruments

Refer to section 4.1.2 to get information of above instrument.

4.5.4 Test Procedure

For AVG. power (duty cycle $\geq 98\%$)

- Set instrument center frequency to DTS channel center frequency.
- Set span to at least 1.5 times the OBW.
- Set RBW to: $3 \text{ kHz} \leq \text{RBW} \leq 100 \text{ kHz}$.
- Set VBW $\geq 3 \times \text{RBW}$.
- Detector = power averaging (RMS) or sample detector (when RMS not available).
- Ensure that the number of measurement points in the sweep $\geq 2 \times \text{span}/\text{RBW}$.
- Sweep time = auto couple.
- Employ trace averaging (RMS) mode over a minimum of 100 traces.
- Use the peak marker function to determine the maximum amplitude level.

For AVG. power (duty cycle $< 98\%$)

- Measure the duty cycle (x).
- Set instrument center frequency to DTS channel center frequency.
- Set span to at least 1.5 times the OBW.
- Set RBW to: $3 \text{ kHz} \leq \text{RBW} \leq 100 \text{ kHz}$.
- Set VBW $\geq 3 \times \text{RBW}$.
- Detector = power averaging (RMS) or sample detector (when RMS not available).
- Ensure that the number of measurement points in the sweep $\geq 2 \times \text{span}/\text{RBW}$.
- Sweep time = auto couple.
- Do not use sweep triggering. Allow sweep to "free run".
- Employ trace averaging (RMS) mode over a minimum of 100 traces.
- Use the peak marker function to determine the maximum amplitude level.
- Add $10 \log (1/x)$, where x is the duty cycle measured in step (a), to the measured PSD to compute the average PSD during the actual transmission time.

4.5.5 Deviation from Test Standard

No deviation.

4.5.6 EUT Operating Condition

Same as item 4.3.6

4.5.7 Test Results

802.11b

TX chain	Channel	Freq. (MHz)	PSD (dBm)	10 log (N=2) dB	Total PSD (dBm)	Limit (dBm)	Pass/Fail
0	1	2412	-4.46	3.01	-1.45	6.07	Pass
	6	2437	-2.81	3.01	0.20	6.07	Pass
	11	2462	-5.77	3.01	-2.76	6.07	Pass
1	1	2412	-5.38	3.01	-2.37	6.07	Pass
	6	2437	-3.48	3.01	-0.47	6.07	Pass
	11	2462	-6.57	3.01	-3.56	6.07	Pass

Note:

- Method 1 of power density measurement of KDB 662911 is using for calculating total power density. Total power density is summing entire spectra across corresponding frequency bins on the various outputs by computer.
- Directional gain = $4.92\text{dBi} + 10\log(2) = 7.93\text{dBi} > 6\text{dBi}$, so the limit shall be reduced to $8-(7.93-6) = 6.07\text{dBm}$.

802.11g

TX chain	Channel	Freq. (MHz)	PSD (dBm)	10 log (N=2) dB	Duty Factor	Total PSD with Duty Factor (dBm)	Limit (dBm)	Pass/Fail
0	1	2412	-12.41	3.01	0.10	-9.30	6.07	Pass
	6	2437	-6.40	3.01	0.10	-3.29	6.07	Pass
	11	2462	-13.25	3.01	0.10	-10.14	6.07	Pass
1	1	2412	-13.07	3.01	0.10	-9.96	6.07	Pass
	6	2437	-6.83	3.01	0.10	-3.72	6.07	Pass
	11	2462	-13.80	3.01	0.10	-10.69	6.07	Pass

Note:

- Method 1 of power density measurement of KDB 662911 is using for calculating total power density. Total power density is summing entire spectra across corresponding frequency bins on the various outputs by computer.
- Directional gain = $4.92\text{dBi} + 10\log(2) = 7.93\text{dBi} > 6\text{dBi}$, so the limit shall be reduced to $8-(7.93-6) = 6.07\text{dBm}$.
- Refer to section 3.3 for duty cycle spectrum plot.

802.11n (HT20)

TX chain	Channel	Freq. (MHz)	PSD (dBm)	10 log (N=2) dB	Total PSD (dBm)	Limit (dBm)	Pass/Fail
0	1	2412	-14.26	3.01	-11.25	6.07	Pass
	6	2437	-7.42	3.01	-4.41	6.07	Pass
	11	2462	-15.01	3.01	-12.00	6.07	Pass
1	1	2412	-15.01	3.01	-12.00	6.07	Pass
	6	2437	-7.76	3.01	-4.75	6.07	Pass
	11	2462	-15.52	3.01	-12.51	6.07	Pass

Note:

- Method 1 of power density measurement of KDB 662911 is using for calculating total power density. Total power density is summing entire spectra across corresponding frequency bins on the various outputs by computer.
- Directional gain = 4.92dBi + 10log(2) = 7.93dBi > 6dBi, so the limit shall be reduced to 8-(7.93-6) = 6.07dBm.

802.11n (HT40)

TX chain	Channel	Freq. (MHz)	PSD (dBm)	10 log (N=2) dB	Duty Factor	Total PSD with Duty Factor (dBm)	Limit (dBm)	Pass/Fail
0	3	2422	-18.71	3.01	0.20	-15.50	6.07	Pass
	6	2437	-15.07	3.01	0.20	-11.86	6.07	Pass
	9	2452	-20.11	3.01	0.20	-16.90	6.07	Pass
1	3	2422	-18.20	3.01	0.20	-14.99	6.07	Pass
	6	2437	-17.50	3.01	0.20	-14.29	6.07	Pass
	9	2452	-20.03	3.01	0.20	-16.82	6.07	Pass

Note:

- Method 1 of power density measurement of KDB 662911 is using for calculating total power density. Total power density is summing entire spectra across corresponding frequency bins on the various outputs by computer.
- Directional gain = 4.92dBi + 10log(2) = 7.93dBi > 6dBi, so the limit shall be reduced to 8-(7.93-6) = 6.07dBm.
- Refer to section 3.3 for duty cycle spectrum plot.

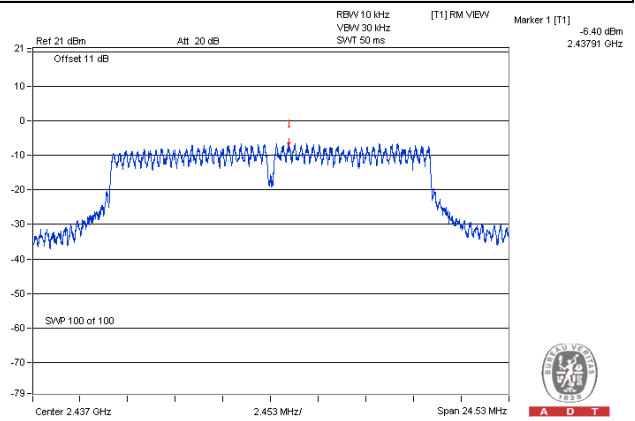
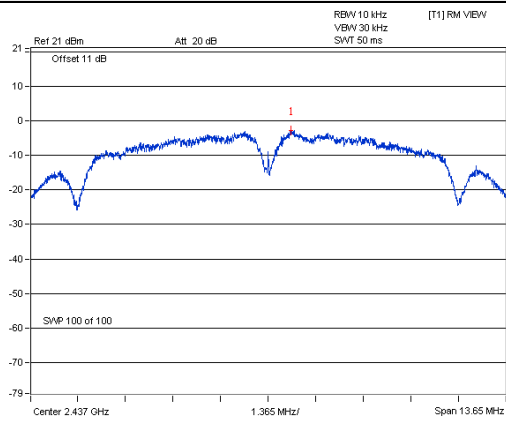
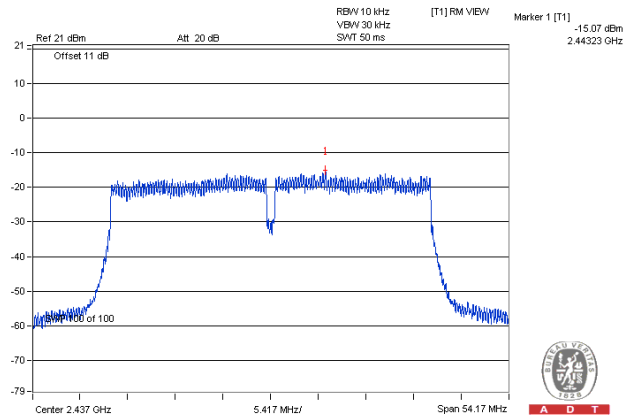
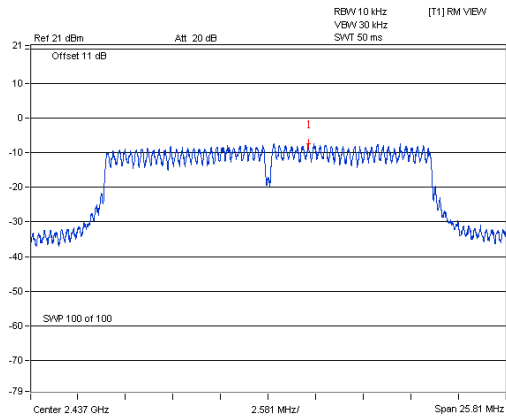
Spectrum Plot of Worst Value**802.11b****802.11g****802.11n (HT20)****802.11n (HT40)**

4.6 Conducted Out of Band Emission Measurement

4.6.1 Limits of Conducted Out of Band Emission Measurement

Below 30dB of the highest emission level of operating band (in 100kHz Resolution Bandwidth).

4.6.2 Test Setup

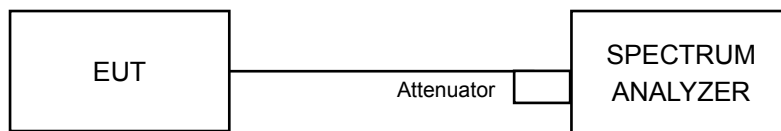

4.6.3 Test Instruments

Refer to section 4.1.2 to get information of above instrument.

4.6.4 Test Procedure

MEASUREMENT PROCEDURE REF

1. Set the RBW = 100 kHz.
2. Set the VBW \geq 300 kHz.
3. Detector = peak.
4. Sweep time = auto couple.
5. Trace mode = max hold.
6. Allow trace to fully stabilize.
7. Use the peak marker function to determine the maximum power level in any 100 kHz band segment within the fundamental EBW.

MEASUREMENT PROCEDURE OOB

1. Set RBW = 100 kHz.
2. Set VBW \geq 300 kHz.
3. Detector = peak.
4. Sweep = auto couple.
5. Trace Mode = max hold.
6. Allow trace to fully stabilize.
7. Use the peak marker function to determine the maximum amplitude level.

4.6.5 Deviation from Test Standard

No deviation.

4.6.6 EUT Operating Condition

Same as item 4.3.6

4.6.7 Test Results

The conducted emission test is performed on each TX port of operating mode without summing or adding 10log (N) since the limit is relative emission limit.

The spectrum plots are attached on the following pages. D1 line indicates the highest level, and D2 line indicates the 30dB offset below D1. It shows compliance with the requirement.

802.11b_CHAIN 0

CH 1

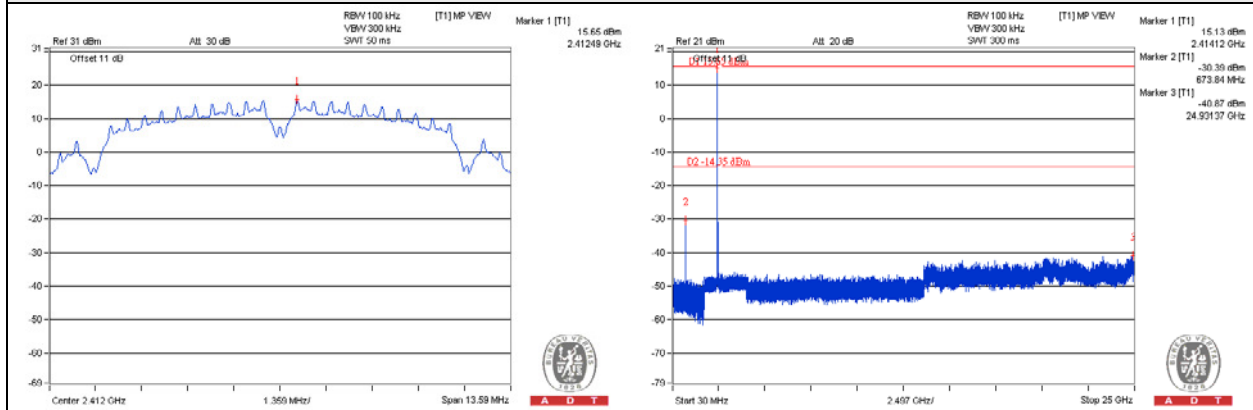

CH 6

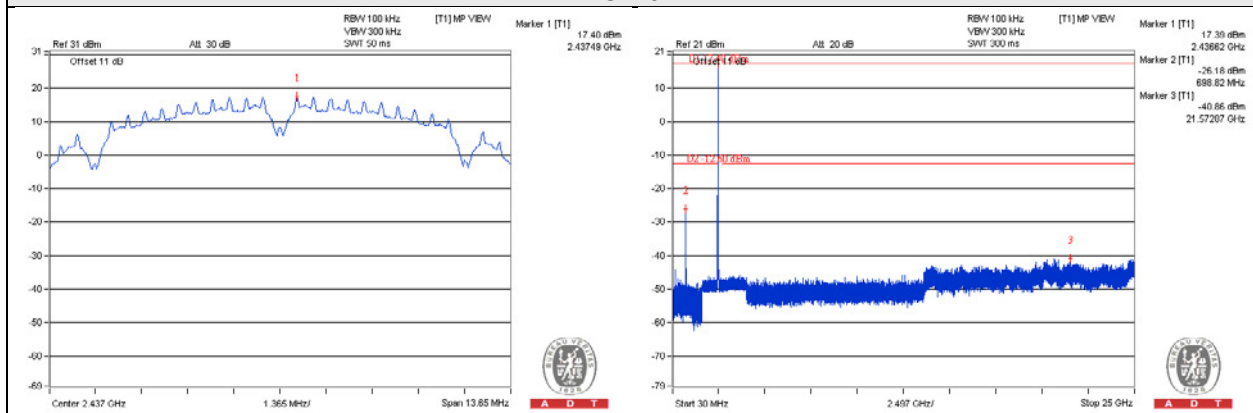

CH 11

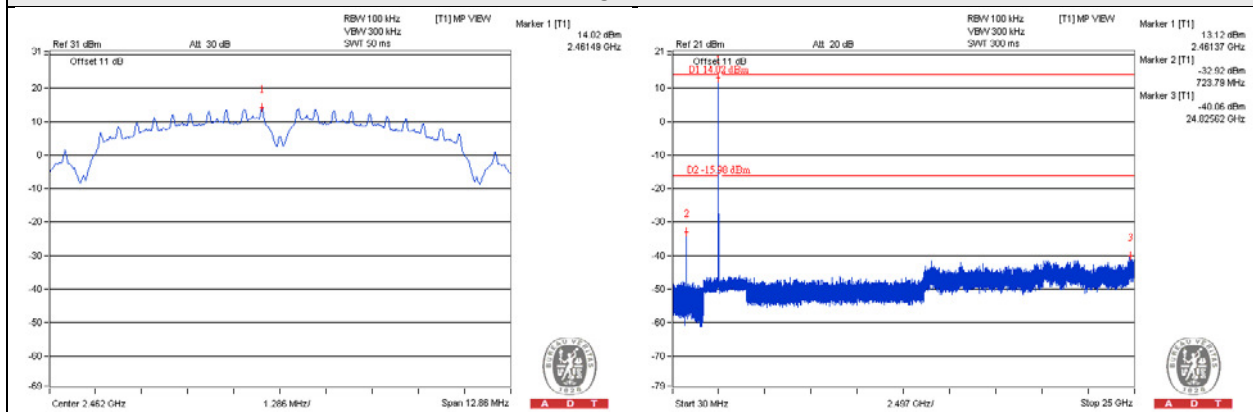

CH 1 Band edge

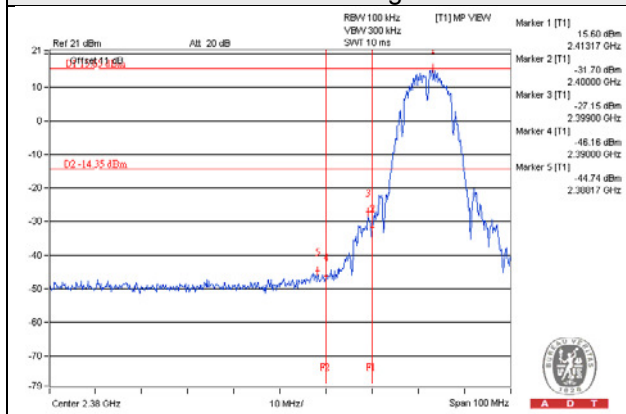

CH 11 Band edge

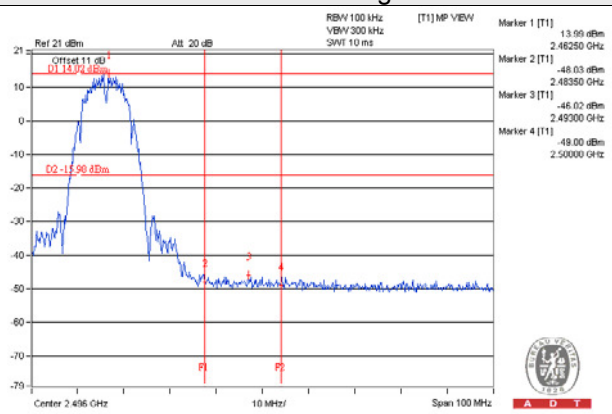

802.11b_CHAIN 1

CH 1

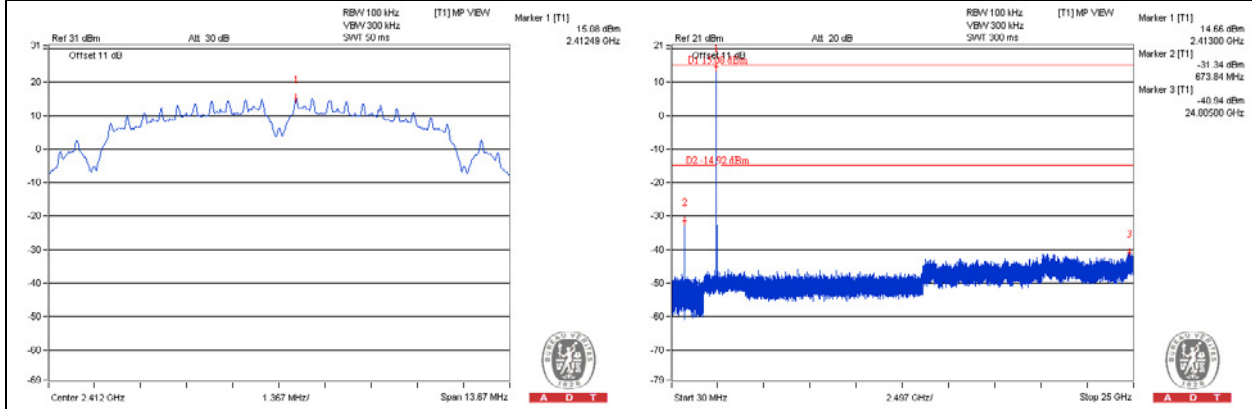

CH 6

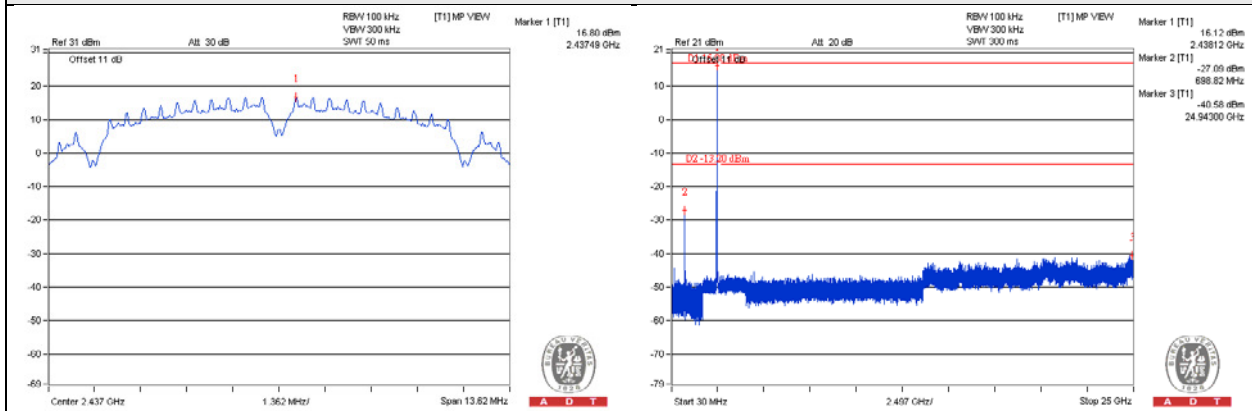

CH 11

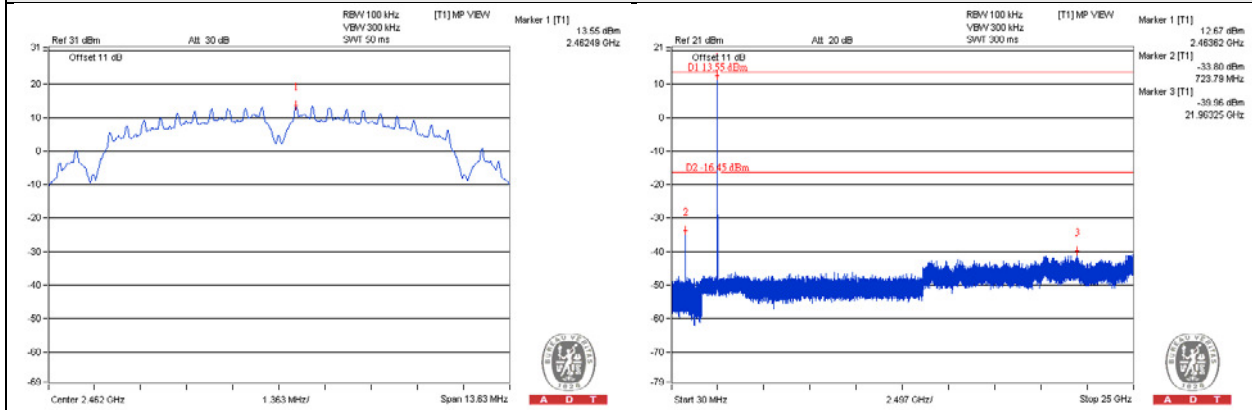

CH 1 Band edge

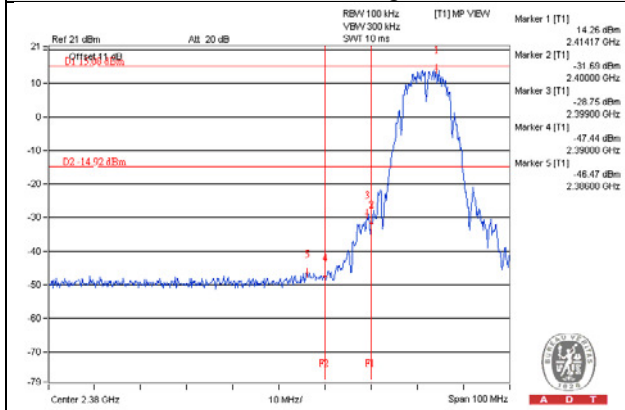

CH 11 Band edge

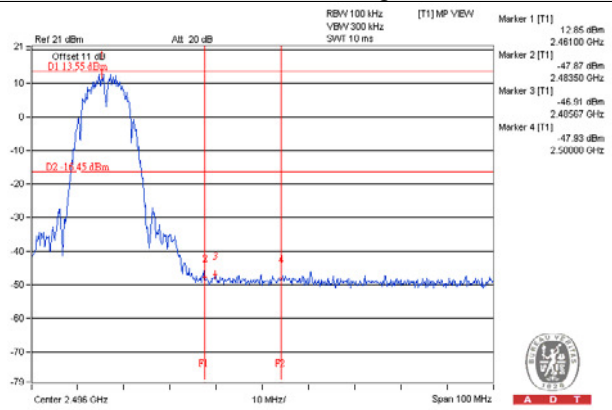

802.11g_CHAIN 0

CH 1

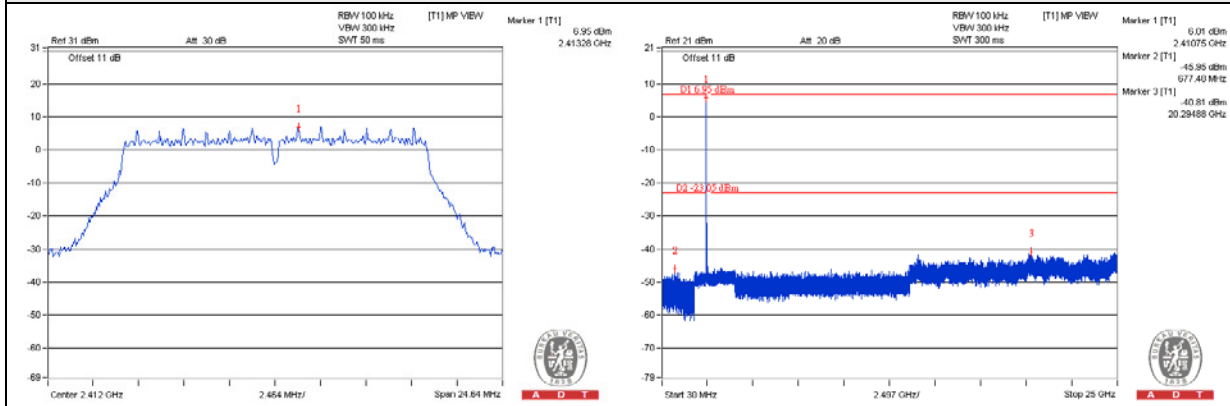

CH 6

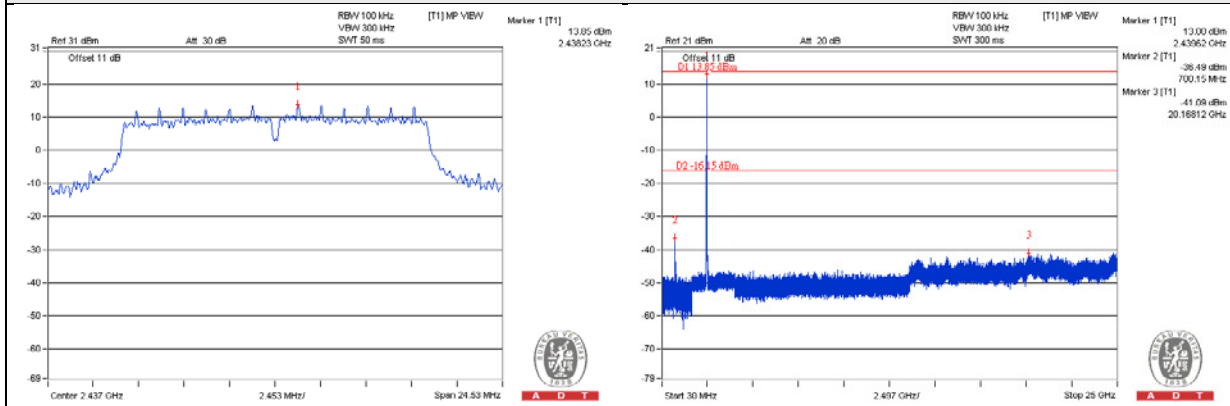

CH 11

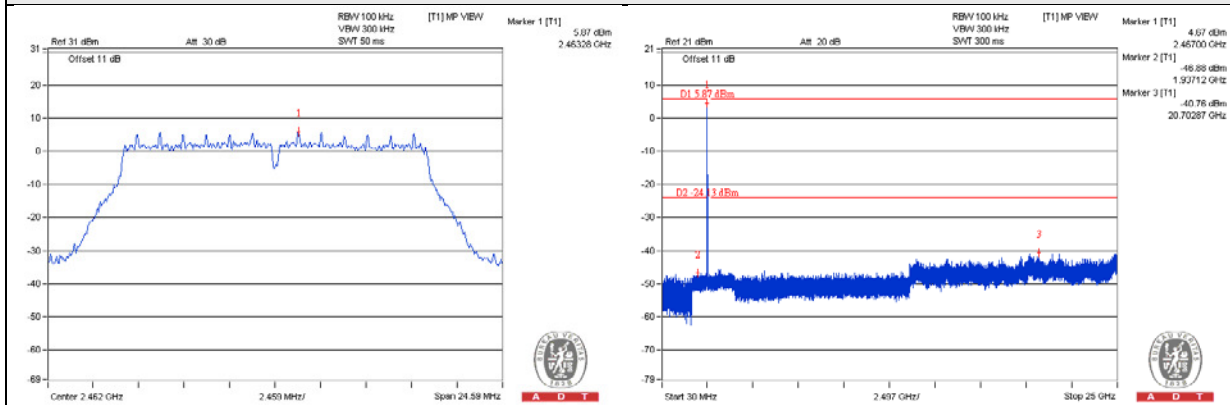

CH 1 Band edge

CH 11 Band edge

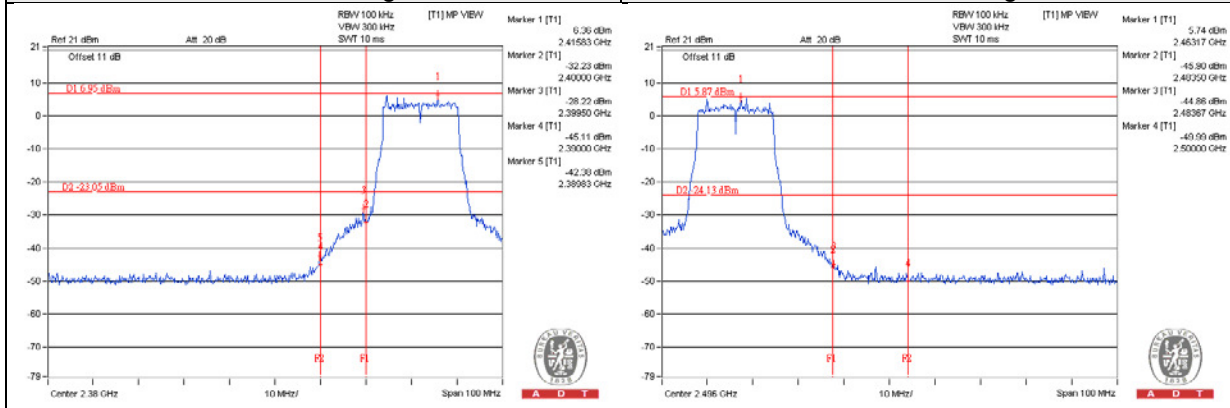

802.11g_CHAIN 1

CH 1

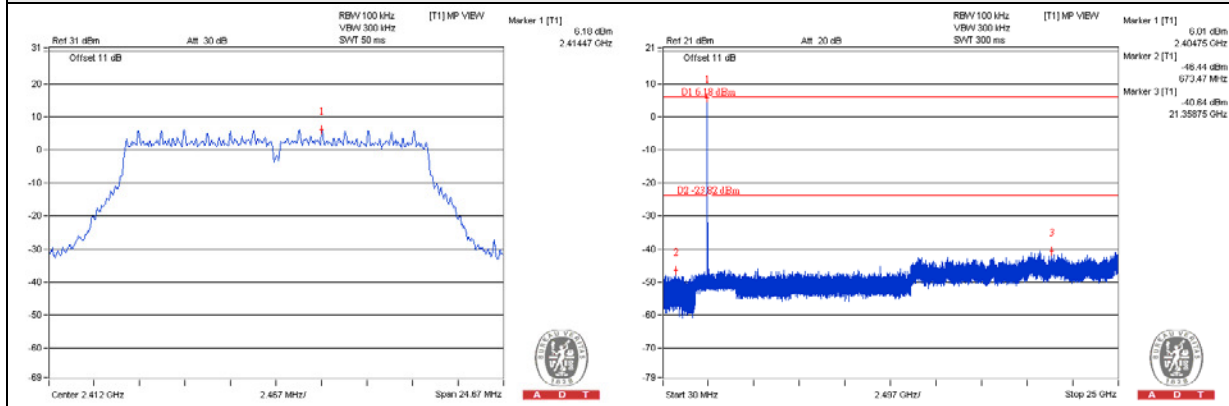

CH 6

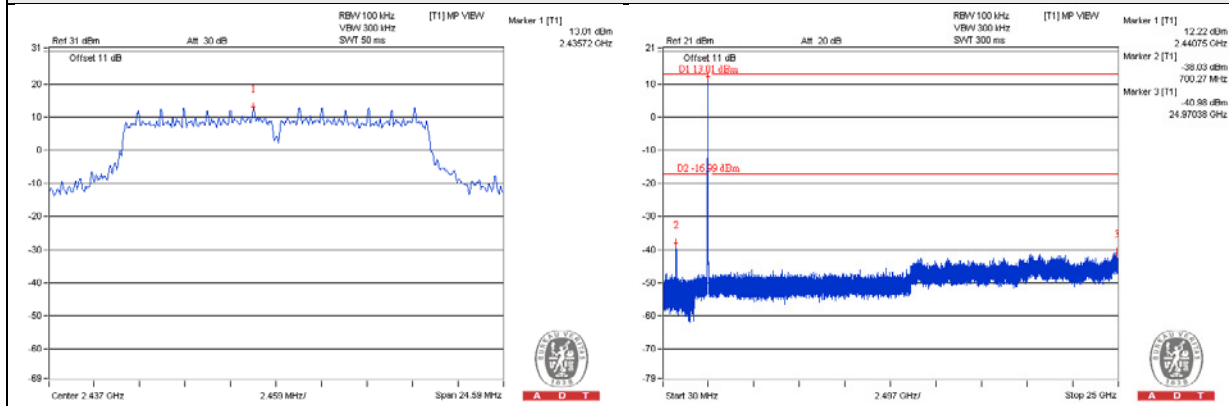

CH 11

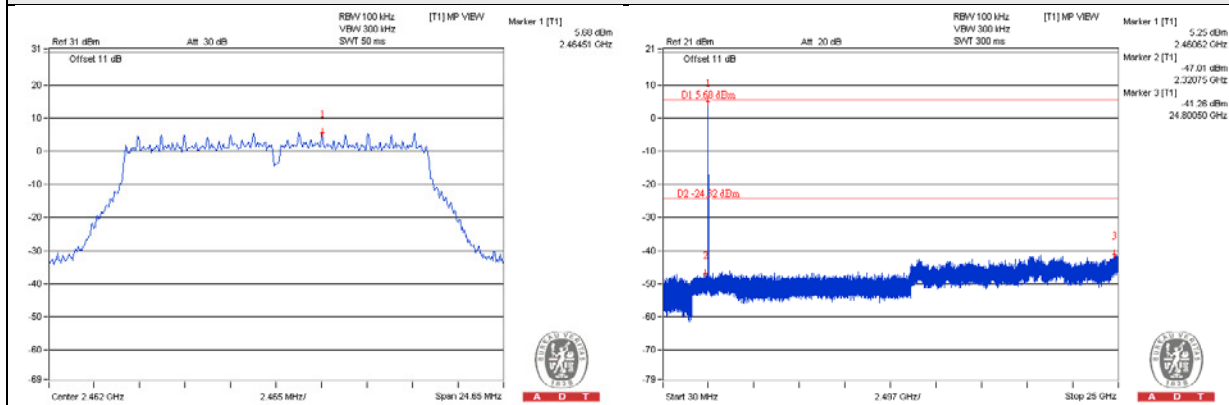

CH 1 Band edge

CH 11 Band edge

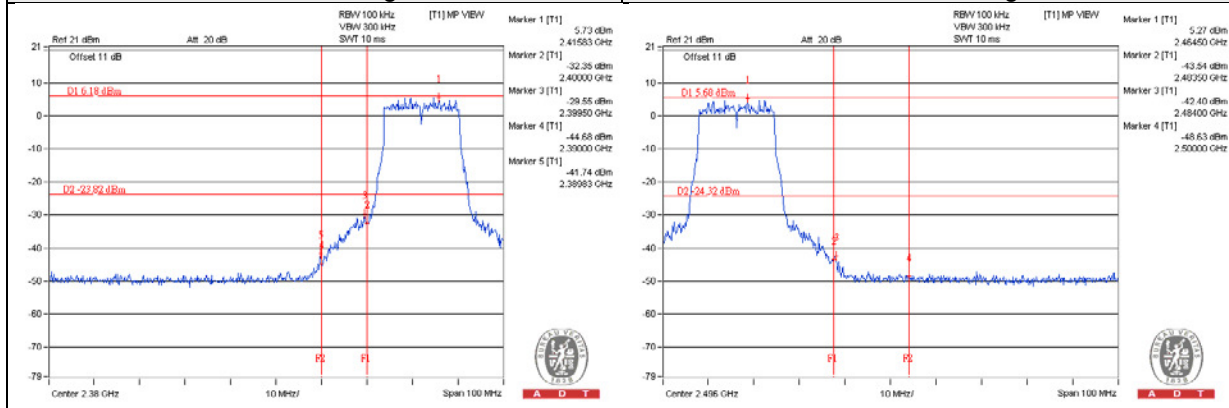

802.11n (HT20)_CHAIN 0

CH 1

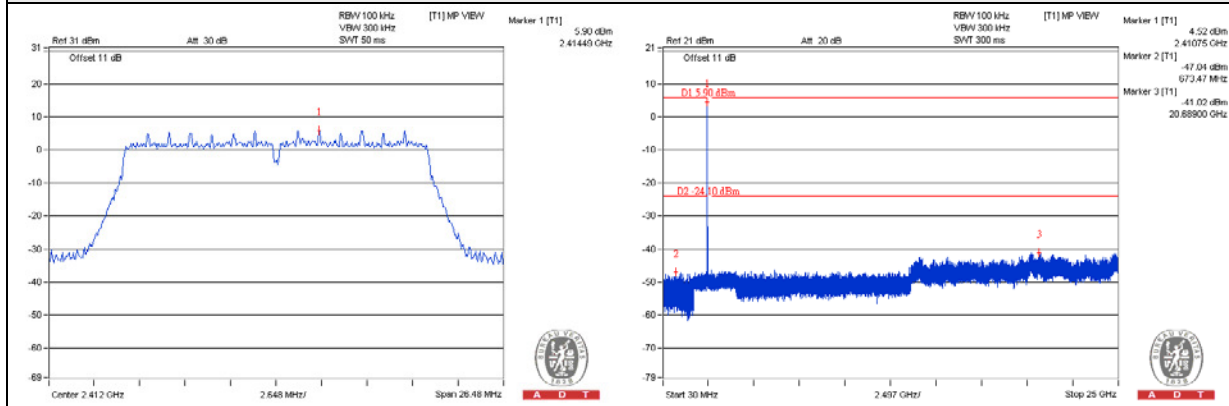

CH 6

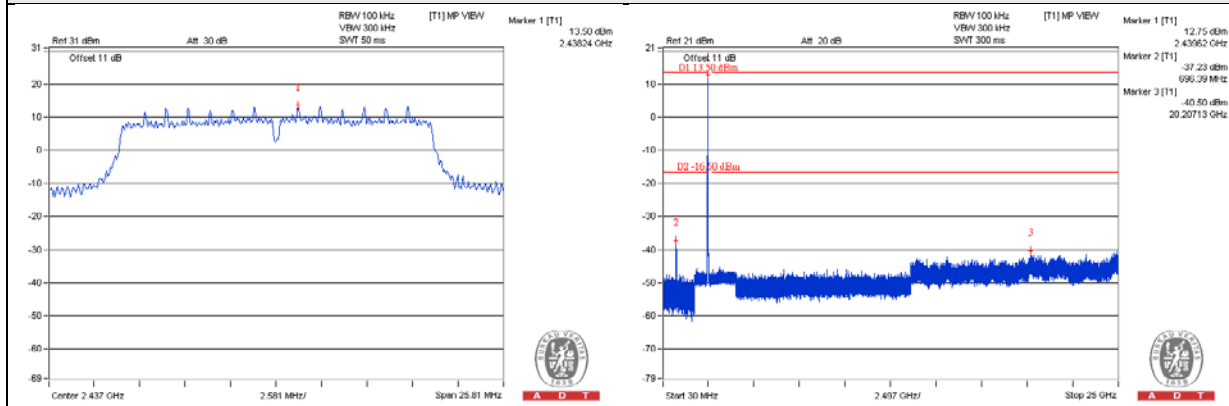

CH 11

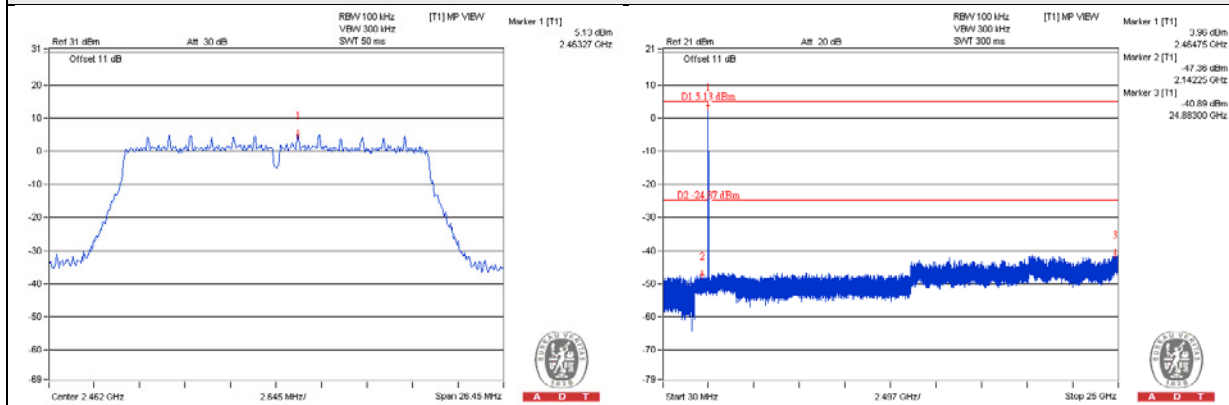

CH 1 Band edge

CH 11 Band edge

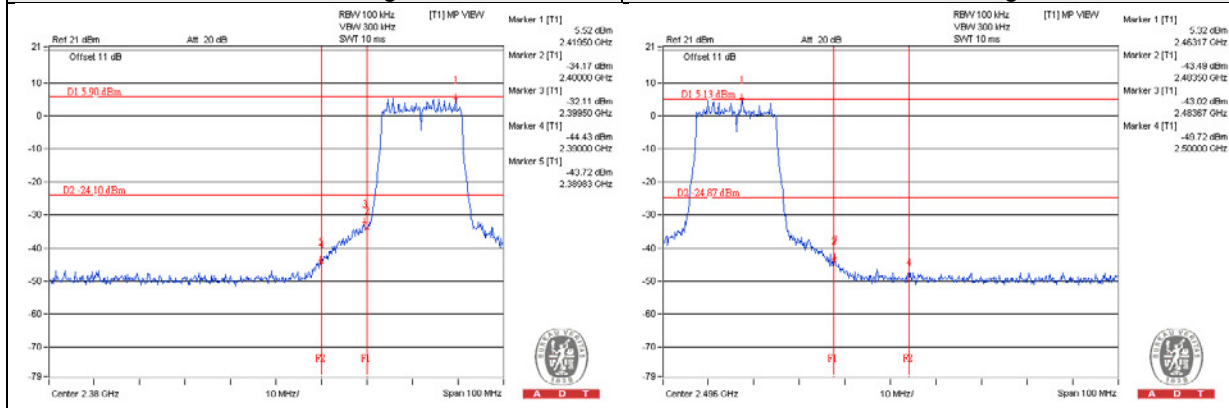

802.11n (HT20)_CHAIN 1

CH 1

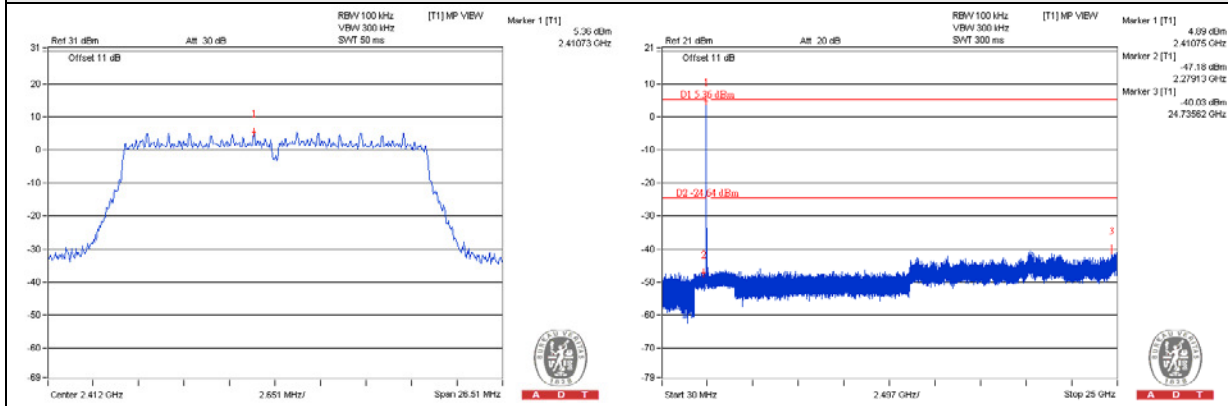

CH 6

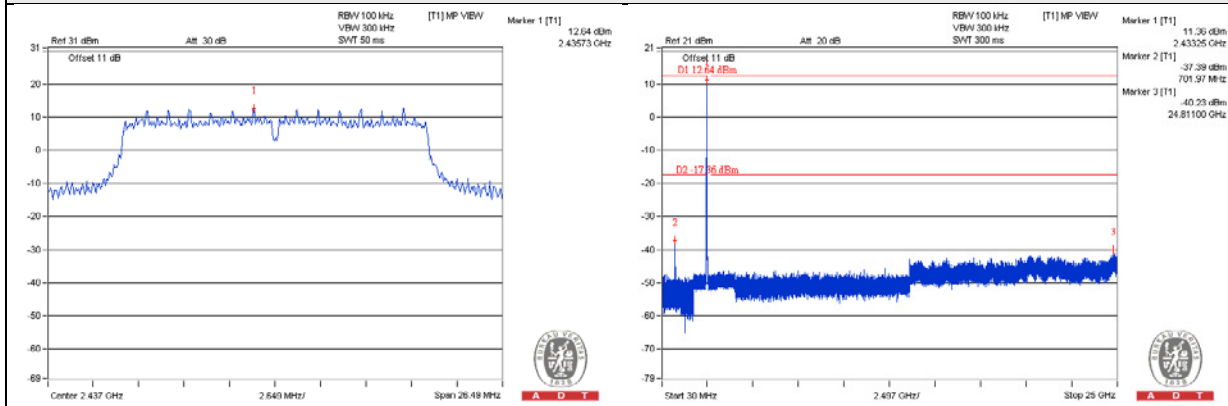

CH 11

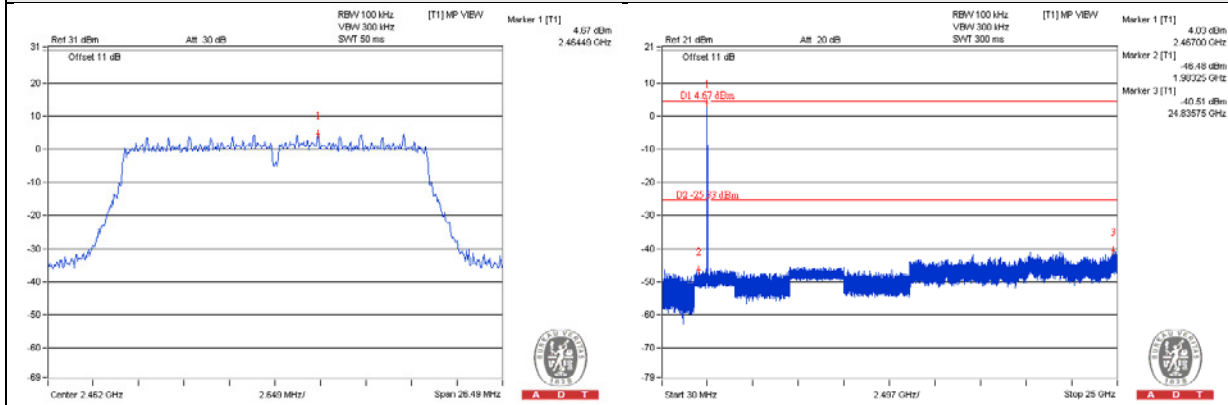

CH 1 Band edge

CH 11 Band edge

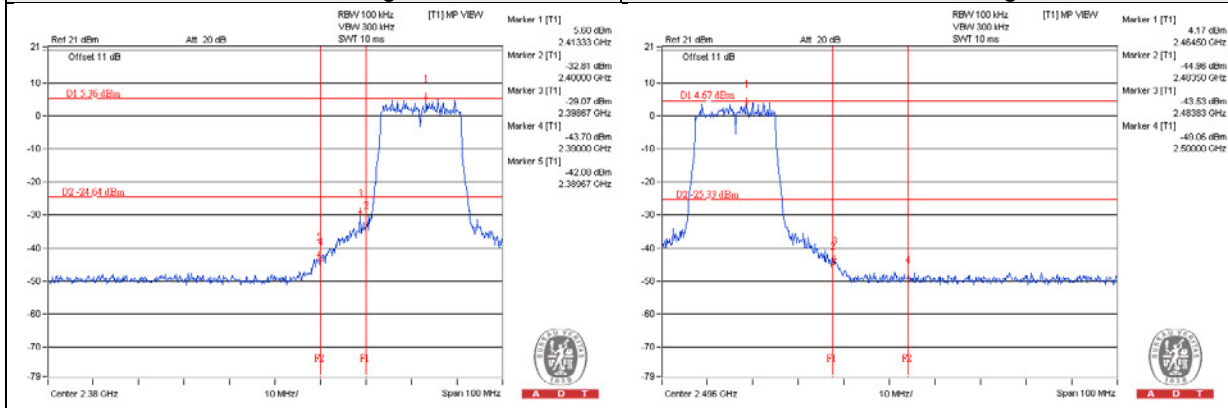

802.11n (HT40)_CHAIN 0

CH 3

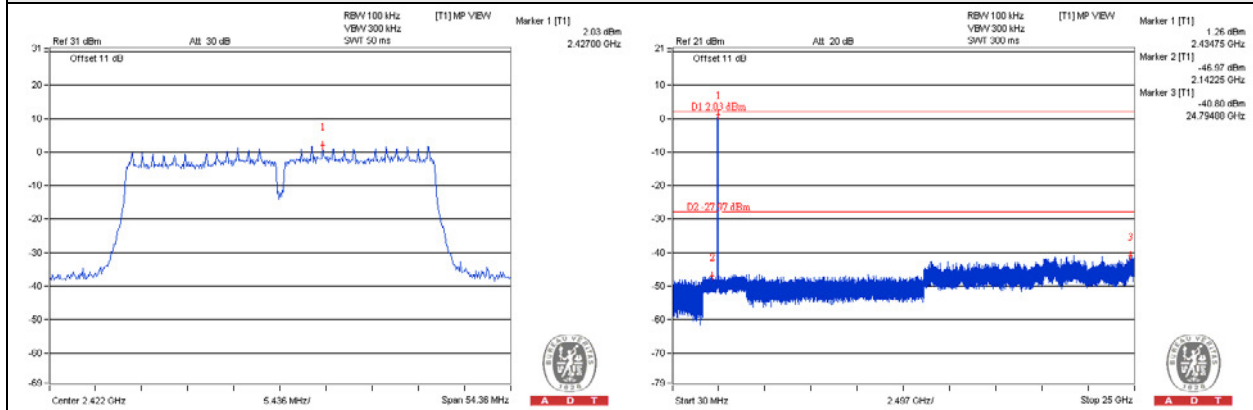

CH 6

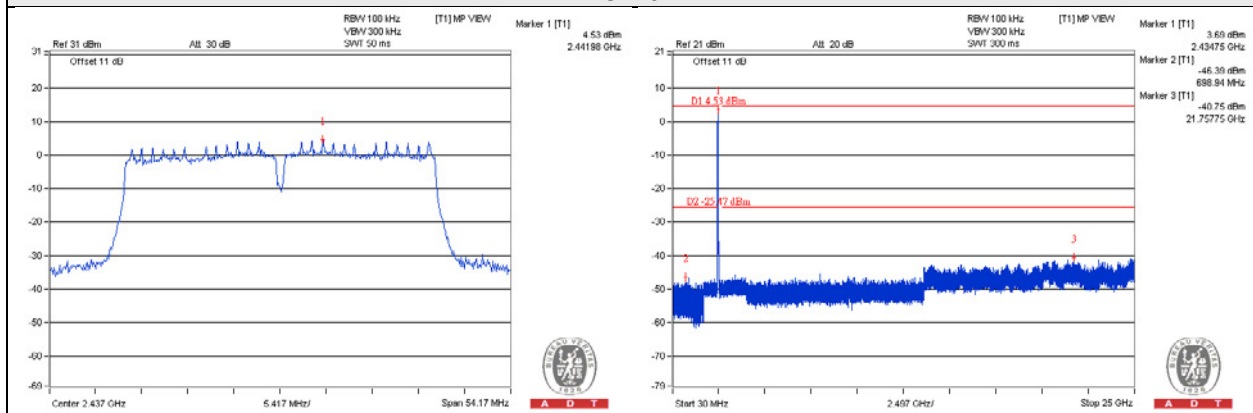

CH 9

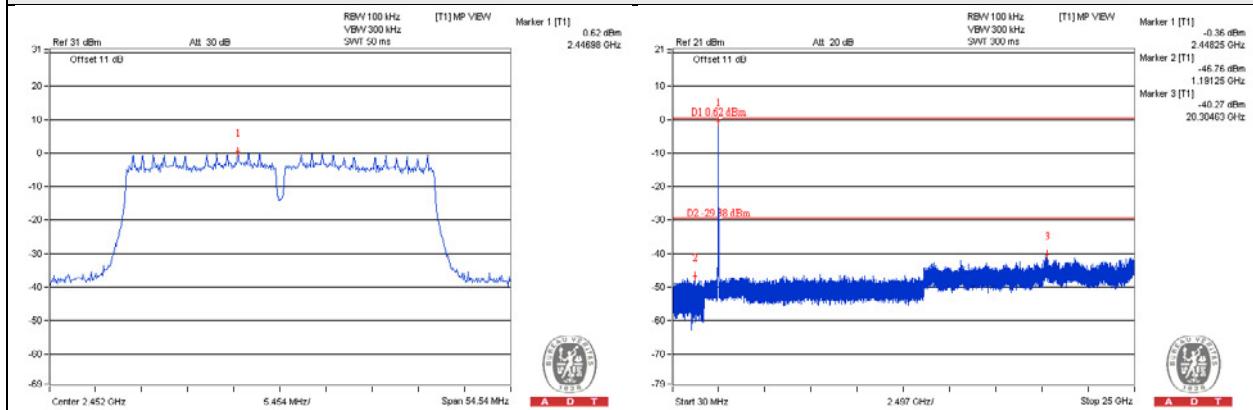

CH 3 Band edge

CH 9 Band edge

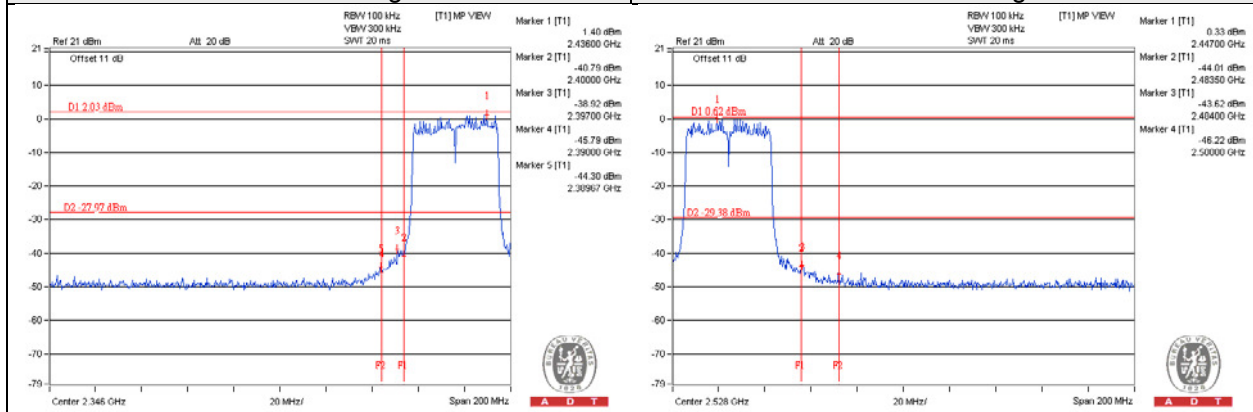

802.11n (HT40)_CHAIN 1

CH 3

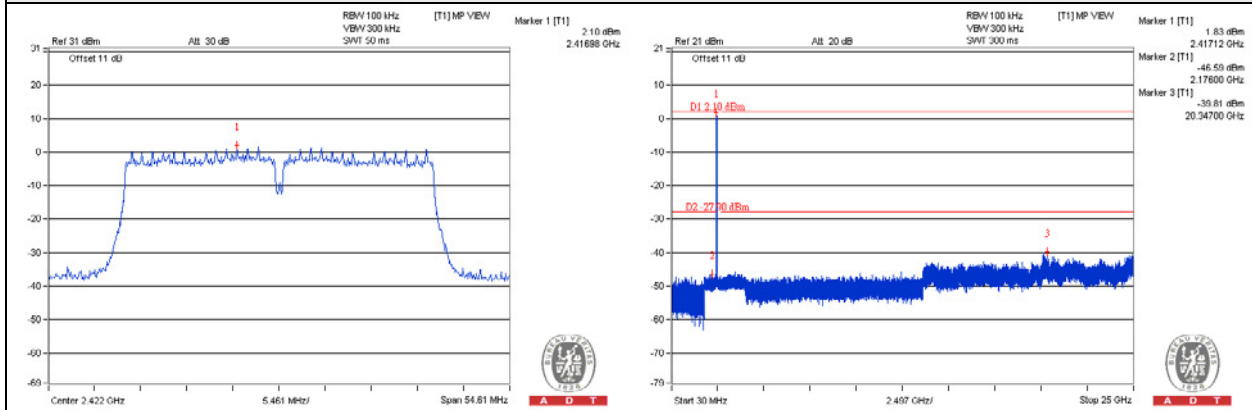

CH 6

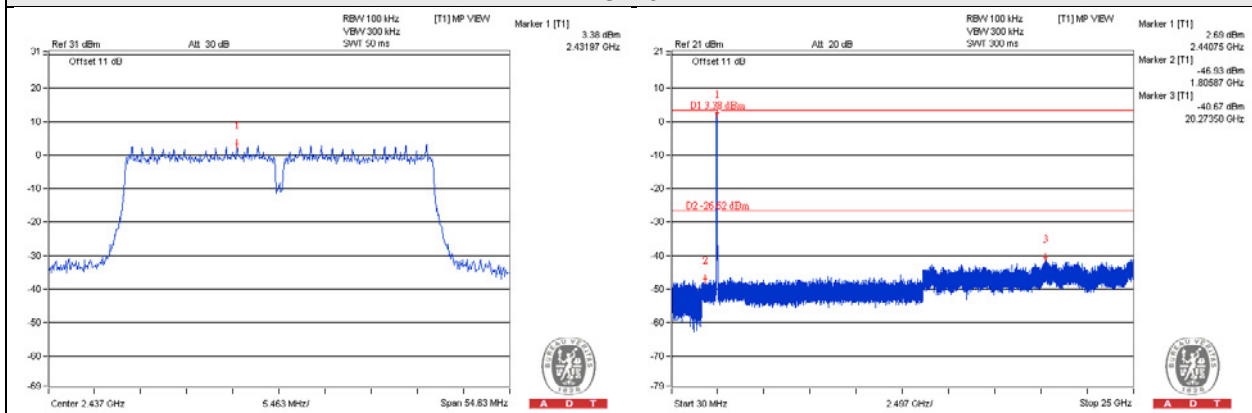

CH 9

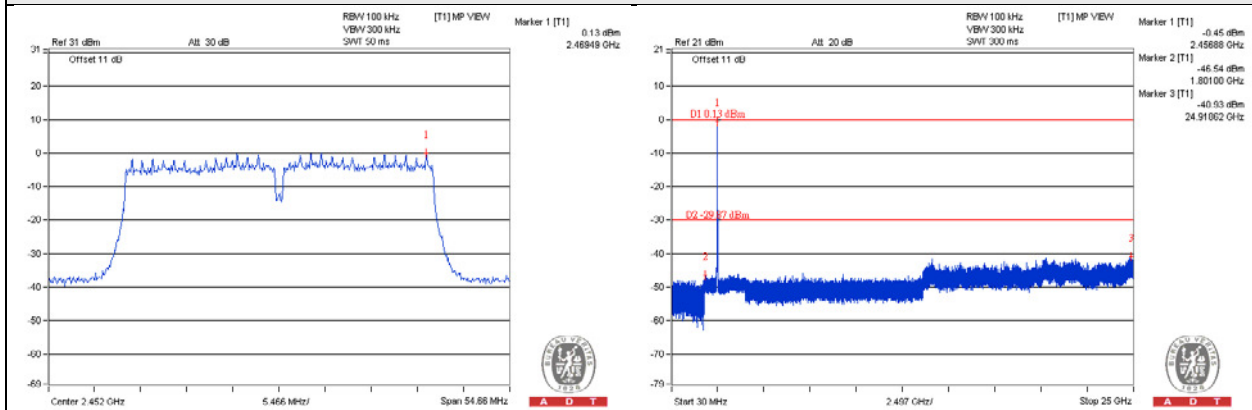

CH 3 Band edge

CH 9 Band edge

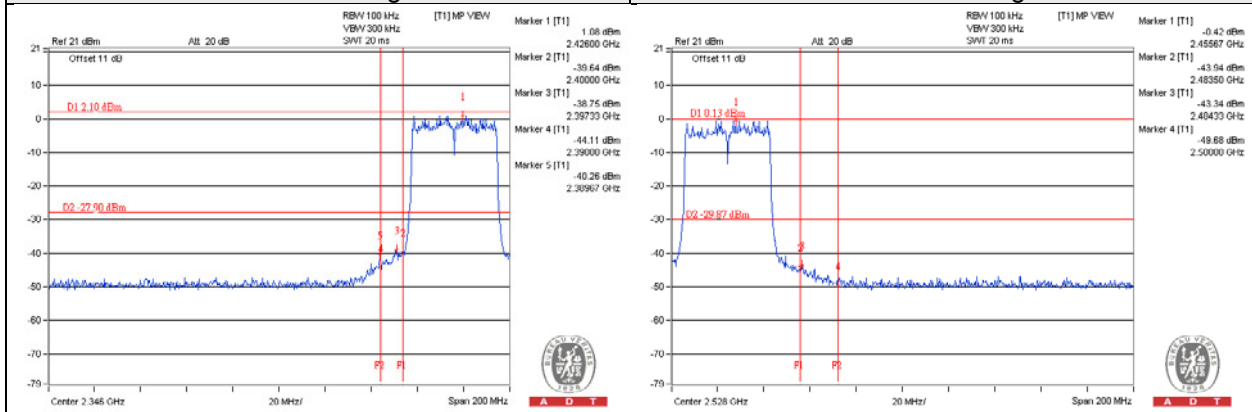

5 Pictures of Test Arrangements

Please refer to the attached file (Test Setup Photo).

Appendix – Information on the Testing Laboratories

We, Bureau Veritas Consumer Products Services (H.K.) Ltd., Taoyuan Branch, were founded in 1988 to provide our best service in EMC, Radio, Telecom and Safety consultation. Our laboratories are accredited and approved according to ISO/IEC 17025.

If you have any comments, please feel free to contact us at the following:

Linko EMC/RF Lab

Tel: 886-2-26052180

Fax: 886-2-26051924

Hsin Chu EMC/RF/Telecom Lab

Tel: 886-3-5935343

Fax: 886-3-5935342

Hwa Ya EMC/RF/Safety Lab

Tel: 886-3-3183232

Fax: 886-3-3270892

Email: service.adt@tw.bureauveritas.com

Web Site: www.bureauveritas-adt.com

The address and road map of all our labs can be found in our web site also.

--- END ---