



FCC TEST REPORT

REPORT NO.: RF950922L13

MODEL NO.: DWL-3140AP

RECEIVED: Sep. 21, 2006

TESTED: Sep. 21, 2006 ~ May 28, 2007

ISSUED: May 30, 2007

APPLICANT: D-Link Corporation

ADDRESS: 17595 Mt. Herrmann, Fountain Valley,
CA 92708, U.S.A.

ISSUED BY: Advance Data Technology Corporation

LAB ADDRESS: 47 14th Lin, Chiapau Tsun, Linko, Taipei, Taiwan,
R.O.C.

TEST LOCATION: No. 19, Hwa Ya 2nd Rd., Kueishan, Taoyuan,
Taiwan, R.O.C.

This test report consists of 84 pages in total. It may be duplicated completely for legal use with the approval of the applicant. It should not be reproduced except in full, without the written approval of our laboratory. The client should not use it to claim product endorsement by CNLA, A2LA or any government agencies. The test results in the report only apply to the tested sample.





Table of Contents

1	CERTIFICATION.....	4
2	SUMMARY OF TEST RESULTS.....	5
2.1	MEASUREMENT UNCERTAINTY	5
3	GENERAL INFORMATION	6
3.1	GENERAL DESCRIPTION OF EUT.....	6
3.2	DESCRIPTION OF TEST MODES	7
3.2.1	CONFIGURATION OF SYSTEM UNDER TEST	7
3.2.2	TEST MODE APPLICABILITY AND TESTED CHANNEL DETAIL.....	9
3.3	GENERAL DESCRIPTION OF APPLIED STANDARDS	11
3.4	DESCRIPTION OF SUPPORT UNITS.....	12
4	TEST TYPES AND RESULTS.....	13
4.1	CONDUCTED EMISSION MEASUREMENT	13
4.1.1	LIMITS OF CONDUCTED EMISSION MEASUREMENT	13
4.1.2	TEST INSTRUMENTS.....	13
4.1.3	TEST PROCEDURES	14
4.1.4	DEVIATION FROM TEST STANDARD	14
4.1.5	TEST SETUP.....	15
4.1.6	EUT OPERATING CONDITIONS.....	15
4.1.7	TEST RESULTS	16
4.2	RADIATED EMISSION MEASUREMENT	32
4.2.1	LIMITS OF RADIATED EMISSION MEASUREMENT.....	32
4.2.2	TEST INSTRUMENTS.....	33
4.2.3	TEST PROCEDURES	34
4.2.4	DEVIATION FROM TEST STANDARD	34
4.2.5	TEST SETUP.....	35
4.2.6	EUT OPERATING CONDITIONS.....	35
4.2.7	TEST RESULTS	36
4.3	6dB BANDWIDTH MEASUREMENT	47
4.3.1	LIMITS OF 6dB BANDWIDTH MEASUREMENT	47
4.3.2	TEST INSTRUMENTS.....	47
4.3.3	TEST PROCEDURE.....	48
4.3.4	DEVIATION FROM TEST STANDARD	48
4.3.5	TEST SETUP.....	48
4.3.6	EUT OPERATING CONDITIONS.....	48
4.3.7	TEST RESULTS	49
4.4	MAXIMUM PEAK OUTPUT POWER.....	56
4.4.1	LIMITS OF MAXIMUM PEAK OUTPUT POWER MEASUREMENT.....	56
4.4.2	TEST INSTRUMENTS.....	56
4.4.3	TEST PROCEDURES	57



4.4.4	DEVIATION FROM TEST STANDARD	57
4.4.5	TEST SETUP.....	57
4.4.6	EUT OPERATING CONDITIONS.....	57
4.4.7	TEST RESULTS	58
4.5	POWER SPECTRAL DENSITY MEASUREMENT	59
4.5.1	LIMITS OF POWER SPECTRAL DENSITY MEASUREMENT.....	59
4.5.2	TEST INSTRUMENTS.....	59
4.5.3	TEST PROCEDURE.....	60
4.5.4	DEVIATION FROM TEST STANDARD	60
4.5.5	TEST SETUP.....	60
4.5.6	EUT OPERATING CONDITIONS.....	60
4.5.7	TEST RESULTS	61
4.6	BAND EDGES MEASUREMENT.....	68
4.6.1	LIMITS OF BAND EDGES MEASUREMENT.....	68
4.6.2	TEST INSTRUMENTS.....	68
4.6.3	TEST PROCEDURE.....	68
4.6.4	DEVIATION FROM TEST STANDARD	68
4.6.5	EUT OPERATING CONDITION	68
4.6.6	TEST RESULTS	69
4.7	ANTENNA REQUIREMENT.....	81
4.7.1	STANDARD APPLICABLE.....	81
4.7.2	ANTENNA CONNECTED CONSTRUCTION.....	81
5	PHOTOGRAPHS OF THE TEST CONFIGURATION.....	82
6	INFORMATION ON THE TESTING LABORATORIES	83
	APPENDIX-A	A-1



1 CERTIFICATION

PRODUCT : Wireless 108G Web Smart Thin AP with PoE
MODEL NO.: DWL-3140AP
BRAND: D-Link
APPLICANT : D-Link Corporation
TESTED: Sep. 21, 2006 ~ May 28, 2007
TEST SAMPLE: ENGINEERING SAMPLE
STANDARDS : **FCC Part 15, Subpart C (Section 15.247),**
ANSI C63.4-2003

The above equipment (model.: DWL-3140AP) have been tested by **Advance Data Technology Corporation**, and found compliance with the requirement of the above standards. The test record, data evaluation & Equipment Under Test (EUT) configurations represented herein are true and accurate accounts of the measurements of the sample's EMC characteristics under the conditions specified in this report.

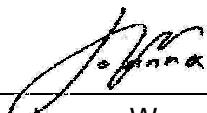
PREPARED BY :  , **DATE:** May 30, 2007
Joanna Wang

TECHNICAL ACCEPTANCE :  , **DATE:** May 30, 2007
Responsible for RF Long Chen

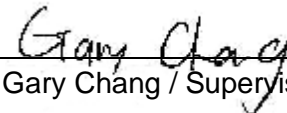
APPROVED BY :  , **DATE:** May 30, 2007
Gary Chang / Supervisor

2 SUMMARY OF TEST RESULTS

The EUT has been tested according to the following specifications:

APPLIED STANDARD: FCC Part 15, Subpart C			
Standard Section	Test Type and Limit	Result	REMARK
15.207	AC Power Conducted Emission	PASS	Meet the requirement of limit. Minimum passing margin is -12.25dB at 0.482MHz.
15.247(a)(2)	Spectrum Bandwidth of a Direct Sequence Spread Spectrum System Limit : min. 500kHz	PASS	Meet the requirement of limit.
15.247(b)	Maximum Peak Output Power Limit: max. 30dBm	PASS	Meet the requirement of limit.
15.247(d)	Transmitter Radiated Emissions Limit: Table 15.209	PASS	Meet the requirement of limit. Minimum passing margin is -1.19dB at 368.21MHz.
15.247(e)	Power Spectral Density Limit: max. 8dBm	PASS	Meet the requirement of limit.
15.247(d)	Band Edge Measurement Limit: 20 dB less than the peak value of fundamental frequency	PASS	Meet the requirement of limit.

2.1 MEASUREMENT UNCERTAINTY

Where relevant, the following measurement uncertainty levels have been estimated for tests performed on the EUT as specified in CISPR 16-4-2:

Measurement	Frequency	Uncertainty
Conducted emissions	9kHz~30MHz	2.44 dB
Radiated emissions	30MHz ~ 200MHz	3.39 dB
	200MHz ~1000MHz	3.43 dB
	1GHz ~ 18GHz	2.26 dB
	18GHz ~ 40GHz	1.94 dB

This uncertainty represents an expanded uncertainty expressed at approximately the 95% confidence level using a coverage factor of k=2.



3 GENERAL INFORMATION

3.1 GENERAL DESCRIPTION OF EUT

PRODUCT	Wireless 108G Web Smart Thin AP with PoE
MODEL NO.	DWL-3140AP
FCC ID	KA2WL3140APA1
POWER SUPPLY	5Vdc from AC adapter 48Vdc from POE
MODULATION TYPE	CCK, DQPSK, DBPSK for DSSS 64QAM, 16QAM, QPSK, BPSK for OFDM
MODULATION TECHNOLOGY	DSSS, OFDM
TRANSFER RATE	802.11b: 11/5.5/2/1Mbps 802.11g: 54/48/36/24/18/12/9/6Mbps (up to 108Mbps for turbo mode)
FREQUENCY RANGE	2412MHz ~ 2462MHz
NUMBER OF CHANNEL	11 for Normal mode / 1 for Turbo mode
MAXIMUM OUTPUT POWER	90.573mW
ANTENNA TYPE	PIFA antenna with 0dBi gain, Chip antenna with 0dBi gain (for receive only)
I/O PORTS	Refer to user's manual
DATA CABLE	NA
ACCESSORY DEVICES	Adapter, POE

NOTE:

1. The EUT were powered by the following adapter and POE:

ADAPTER	
BRAND:	JENTEC TECHNOLOGY CO., LTD.
MODEL:	JTAE0402D-A
INPUT:	100-240Vac, 50-60Hz, 0.25A
OUTPUT:	+5Vdc, 1.2A
POWER LINE:	1.8m non-shielded cable without core

POE	
BRAND:	D-Link
MODEL:	DES-1228P
INPUT:	100-240Vac, 50-60Hz, 3.5A
OUTPUT:	48Vdc

2. The EUT complies with IEEE 802.11g standards and backwards compatible with IEEE 802.11b products.
3. The EUT operates in the 2.4GHz frequency spectrum with throughput of up to 108Mbps.
4. The above EUT information was declared by manufacturer and for more detailed features description, please refer to the manufacturer's specifications or User's Manual.

3.2 DESCRIPTION OF TEST MODES

For 802.11b/g: 11 channels are provided to this EUT for normal mode.

CHANNEL	FREQUENCY	CHANNEL	FREQUENCY
1	2412 MHz	7	2442 MHz
2	2417 MHz	8	2447 MHz
3	2422 MHz	9	2452 MHz
4	2427 MHz	10	2457 MHz
5	2432 MHz	11	2462 MHz
6	2437 MHz		

For 802.11g: One channel is provided to this EUT for turbo mode.

CHANNEL	FREQUENCY
6	2437 MHz

3.2.1 CONFIGURATION OF SYSTEM UNDER TEST

Test Mode A

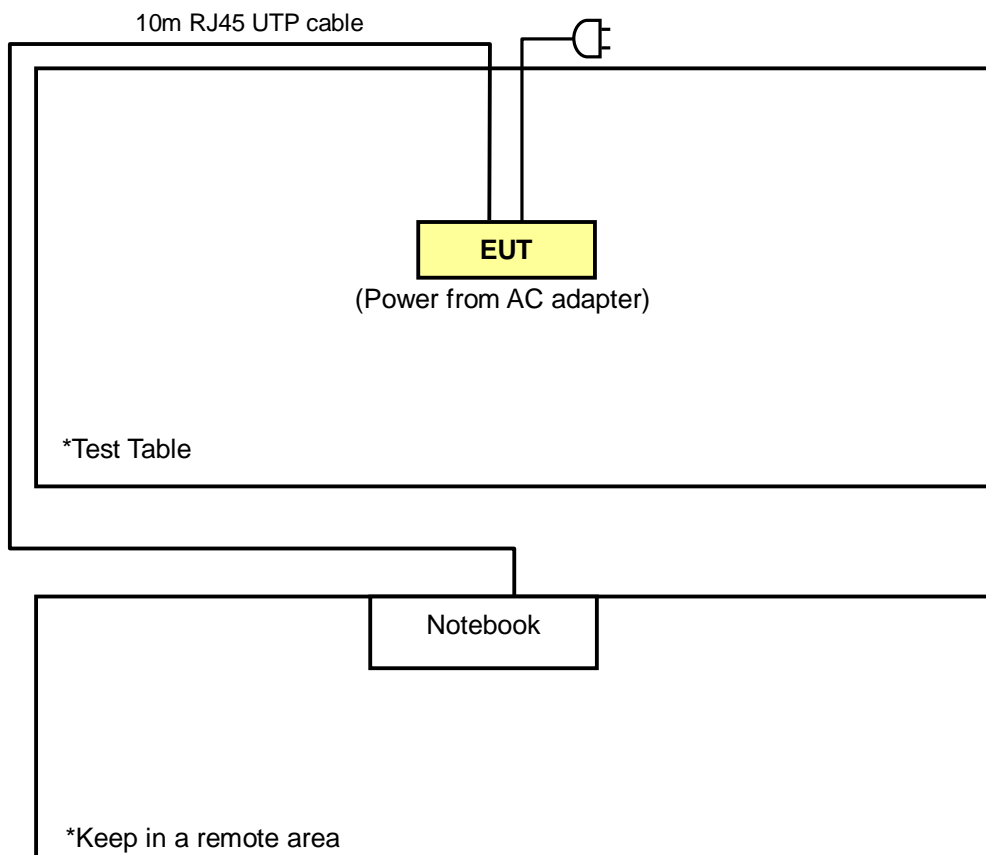

Test Mode B

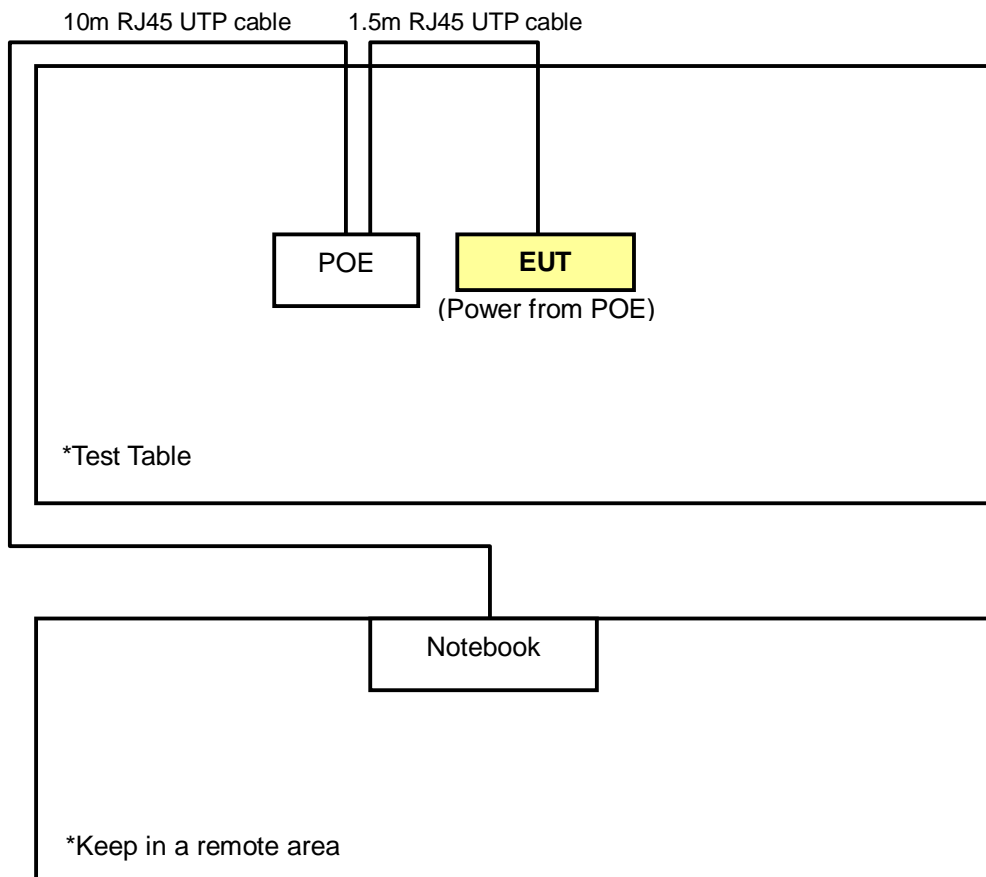

3.2.2 TEST MODE APPLICABILITY AND TESTED CHANNEL DETAIL

EUT configure mode	Applicable to				Description
	PLC	RE<1G	RE ^{>} 1G	APCM	
A	√	√	-	-	Power from adapter
B	√	√	√	√	Power from POE

Where **PLC**: Power Line Conducted Emission **RE<1G**: Radiated Emission below 1GHz
RE[>]1G: Radiated Emission above 1GHz **APCM**: Antenna Port Conducted Measurement

NOTE: "-" means no effect

Power Line Conducted Emission Test:

- Pre-Scan has been conducted to determine the worst-case mode from all possible combinations between available modulations, data rates and antenna ports (if EUT with antenna diversity architecture).
- Following channel(s) was (were) selected for the final test as listed below.

EUT CONFIGURE MODE	Mode	Available Channel	Tested Channel	Modulation Technology	Modulation Type	Data Rate (Mbps)
A	802.11g	1 to 11	1, 6, 11	OFDM	BPSK	6
	802.11g Turbo	6	6	OFDM	QPSK	12
B	802.11g	1 to 11	1, 6, 11	OFDM	BPSK	6
	802.11g Turbo	6	6	OFDM	QPSK	12

Radiated Emission Test (Below 1 GHz):

- Pre-Scan has been conducted to determine the worst-case mode from all possible combinations between available modulations, data rates and antenna ports (if EUT with antenna diversity architecture).
- Following channel(s) was (were) selected for the final test as listed below.

EUT CONFIGURE MODE	Mode	Available Channel	Tested Channel	Modulation Technology	Modulation Type	Data Rate (Mbps)
A	802.11g	1 to 11	11	OFDM	BPSK	6
	802.11g Turbo	6	6	OFDM	QPSK	12
B	802.11g	1 to 11	11	OFDM	BPSK	6
	802.11g Turbo	6	6	OFDM	QPSK	12



Radiated Emission Test (Above 1 GHz):

- Pre-Scan has been conducted to determine the worst-case mode from all possible combinations between available modulations, data rates and antenna ports (if EUT with antenna diversity architecture).
- Following channel(s) was (were) selected for the final test as listed below.

EUT CONFIGURE MODE	Mode	Available Channel	Tested Channel	Modulation Technology	Modulation Type	Data Rate (Mbps)
B	802.11b	1 to 11	1, 6, 11	DSSS	DBPSK	1
	802.11g	1 to 11	1, 6, 11	OFDM	BPSK	6
	802.11g Turbo	6	6	OFDM	QPSK	12

Bandedge Measurement:

- Pre-Scan has been conducted to determine the worst-case mode from all possible combinations between available modulations, data rates and antenna ports (if EUT with antenna diversity architecture).
- Following channel(s) was (were) selected for the final test as listed below.

Mode	Available Channel	Tested Channel	Modulation Technology	Modulation Type	Data Rate (Mbps)
802.11b	1 to 11	1, 11	DSSS	DBPSK	1
802.11g	1 to 11	1, 11	OFDM	BPSK	6
802.11g Turbo	6	6	OFDM	QPSK	12

Antenna Port Conducted Measurement:

- Pre-Scan has been conducted to determine the worst-case mode from all possible combinations between available modulations, data rates and antenna ports (if EUT with antenna diversity architecture).
- Following channel(s) was (were) selected for the final test as listed below.

Mode	Available Channel	Tested Channel	Modulation Technology	Modulation Type	Data Rate (Mbps)
802.11b	1 to 11	1, 6, 11	DSSS	DBPSK	1
802.11g	1 to 11	1, 6, 11	OFDM	BPSK	6
802.11g Turbo	6	6	OFDM	QPSK	12



3.3 GENERAL DESCRIPTION OF APPLIED STANDARDS

The EUT is a RF product. According to the specifications of the manufacturer, it must comply with the requirements of the following standards:

FCC Part 15, Subpart C. (15.247)
ANSI C63.4-2003

All test items have been performed and recorded as per the above standards.

NOTE: The EUT is also considered as a kind of computer peripheral, because the connection to computer is necessary for typical use. It has been verified to comply with the requirements of FCC Part 15, Subpart B, Class B (DoC). The test report has been issued separately.



3.4 DESCRIPTION OF SUPPORT UNITS

The EUT has been tested as an independent unit together with other necessary accessories or support units. The following support units or accessories were used to form a representative test configuration during the tests.

NO.	PRODUCT	BRAND	MODEL NO.	SERIAL NO.	FCC ID
1	NOTEBOOK COMPUTER	DELL	PP05L	16484462992	E2K24CLNS

NO.	SIGNAL CABLE DESCRIPTION OF THE ABOVE SUPPORT UNITS
1	10m RJ45 UTP cable

NOTE:

1. All power cords of the above support units are non shielded (1.8m).
2. Item 1 acted as communication partners to transfer data.



4 TEST TYPES AND RESULTS

4.1 CONDUCTED EMISSION MEASUREMENT

4.1.1 LIMITS OF CONDUCTED EMISSION MEASUREMENT

FREQUENCY OF EMISSION (MHz)	CONDUCTED LIMIT (dB μ V)	
	Quasi-peak	Average
0.15-0.5	66 to 56	56 to 46
0.5-5	56	46
5-30	60	50

- NOTE:**
1. The lower limit shall apply at the transition frequencies.
 2. The limit decreases in line with the logarithm of the frequency in the range of 0.15 to 0.50 MHz.
 3. All emanations from a class A/B digital device or system, including any network of conductors and apparatus connected thereto, shall not exceed the level of field strengths specified above.

4.1.2 TEST INSTRUMENTS

DESCRIPTION & MANUFACTURER	MODEL NO.	SERIAL NO.	CALIBRATED UNTIL
Test Receiver ROHDE & SCHWARZ	ESCS30	100288	Sep. 25, 2007
RF signal cable Woken	5D-FB	Cable-HYCO3-0 1	Jan. 06, 2008
LISN ROHDE & SCHWARZ	ESH2-Z5	100100	Jan. 08, 2008
LISN ROHDE & SCHWARZ	ESH3-Z5	100311	Jan. 16, 2008
Software ADT	ADT_Cond_V3	NA	NA

- NOTE:**
1. The calibration interval of the above test instruments is 12 months and the calibrations are traceable to NML/ROC and NIST/USA.
 2. The test was performed in HwaYa Shielded Room 2.
 3. The VCCI Site Registration No. is C-2047.



4.1.3 TEST PROCEDURES

- a. The EUT was placed 0.4 meters from the conducting wall of the shielded room with EUT being connected to the power mains through a line impedance stabilization network (LISN). Other support units were connected to the power mains through another LISN. The two LISNs provide 50 ohm/ 50uH of coupling impedance for the measuring instrument.
- b. Both lines of the power mains connected to the EUT were checked for maximum conducted interference.
- c. The frequency range from 150kHz to 30MHz was searched. Emission levels under Limit - 20dB was not recorded.

4.1.4 DEVIATION FROM TEST STANDARD

No deviation

4.1.5 TEST SETUP

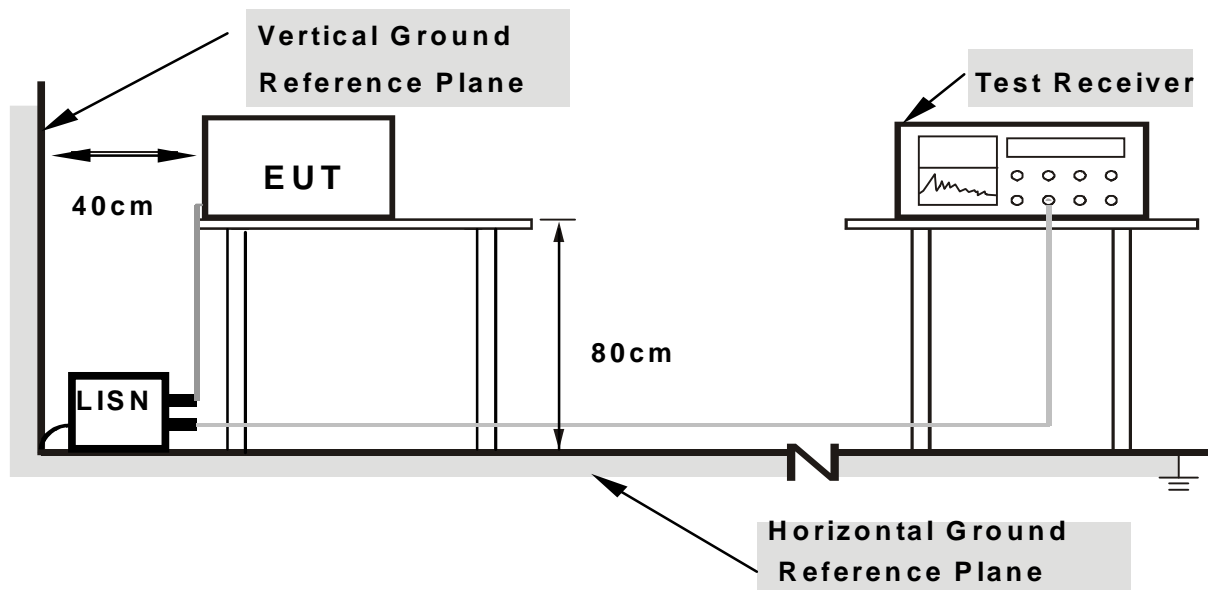

- Note:**
1. Support units were connected to second LISN.
 2. Both of LISNs (AMN) are 80 cm from EUT and at least 80 cm from other units and other metal planes

For the actual test configuration, please refer to the attached file (Test Setup Photo).

4.1.6 EUT OPERATING CONDITIONS

- a. Connected the EUT with the notebook system via RJ45 cable, and placed on a testing table.
- b. The notebook system connected with EUT and run a test program (provided by manufacturer) to enable EUT under transmission condition continuously at specific channel frequency.
- c. The necessary accessories enable the system in full functions.

4.1.7 TEST RESULTS

CONDUCTED WORST-CASE DATA_NORMAL MODE

EUT TEST CONDITION		MEASUREMENT DETAIL	
CHANNEL	Channel 1	PHASE	Line 1
MODULATION TYPE	BPSK	6dB BANDWIDTH	9 kHz
TRANSFER RATE	6Mbps	INPUT POWER (SYSTEM)	120Vac, 60 Hz
ENVIRONMENTAL CONDITIONS	20deg. C, 60%RH, 991hPa	TEST MODE	A
TESTED BY	Match Tsui		

No	Freq. [MHz]	Corr. Factor [dB]	Reading Value [dB (uV)]		Emission Level [dB (uV)]		Limit [dB (uV)]		Margin (dB)	
			Q.P.	AV.	Q.P.	AV.	Q.P.	AV.	Q.P.	AV.
1	0.177	0.10	42.89	-	42.99	-	64.61	54.61	-21.62	-
2	0.236	0.10	37.86	-	37.96	-	62.24	52.24	-24.28	-
3	0.295	0.10	40.77	-	40.87	-	60.40	50.40	-19.53	-
4	0.709	0.11	28.47	-	28.58	-	56.00	46.00	-27.42	-
5	1.535	0.17	22.65	-	22.82	-	56.00	46.00	-33.18	-
6	23.824	0.76	15.24	-	16.00	-	60.00	50.00	-44.00	-

- REMARKS:**
1. Q.P. and AV. are abbreviations of quasi-peak and average individually.
 2. "-": The Quasi-peak reading value also meets average limit and measurement with the average detector is unnecessary.
 3. The emission levels of other frequencies were very low against the limit.
 4. Margin value = Emission level - Limit value
 5. Correction factor = Insertion loss + Cable loss
 6. Emission Level = Correction Factor + Reading Value.

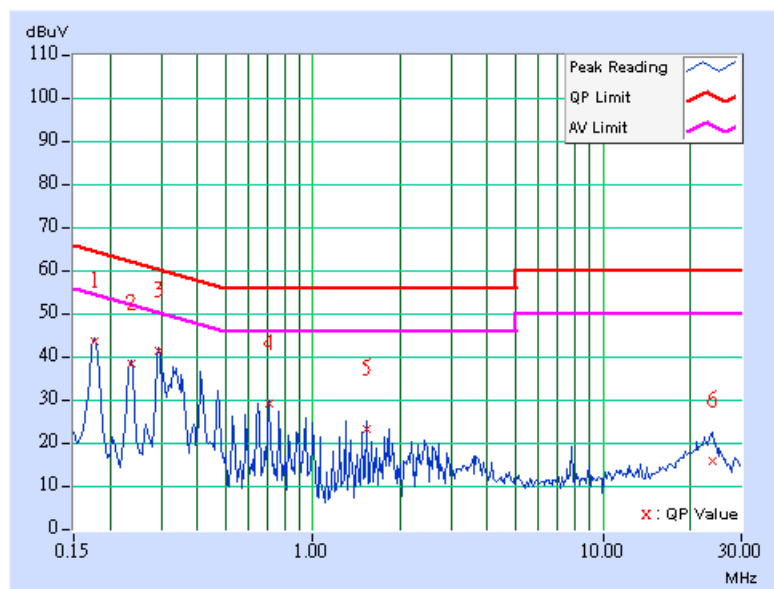

EUT TEST CONDITION		MEASUREMENT DETAIL	
CHANNEL	Channel 1	PHASE	Line 2
MODULATION TYPE	BPSK	6dB BANDWIDTH	9 kHz
TRANSFER RATE	6Mbps	INPUT POWER (SYSTEM)	120Vac, 60 Hz
ENVIRONMENTAL CONDITIONS	20deg. C, 60%RH, 991hPa	TEST MODE	A
TESTED BY	Match Tsui		

No	Freq. [MHz]	Corr. Factor [dB]	Reading Value [dB (uV)]		Emission Level [dB (uV)]		Limit [dB (uV)]		Margin (dB)	
			Q.P.	AV.	Q.P.	AV.	Q.P.	AV.	Q.P.	AV.
1	0.177	0.10	43.37	-	43.47	-	64.61	54.61	-21.14	-
2	0.236	0.10	37.92	-	38.02	-	62.24	52.24	-24.22	-
3	0.295	0.10	35.66	-	35.76	-	60.40	50.40	-24.64	-
4	0.709	0.16	27.76	-	27.92	-	56.00	46.00	-28.08	-
5	1.828	0.22	26.51	-	26.73	-	56.00	46.00	-29.27	-
6	24.449	0.70	13.37	-	14.07	-	60.00	50.00	-45.93	-

- REMARKS:**
1. Q.P. and AV. are abbreviations of quasi-peak and average individually.
 2. "-": The Quasi-peak reading value also meets average limit and measurement with the average detector is unnecessary.
 3. The emission levels of other frequencies were very low against the limit.
 4. Margin value = Emission level - Limit value
 5. Correction factor = Insertion loss + Cable loss
 6. Emission Level = Correction Factor + Reading Value.

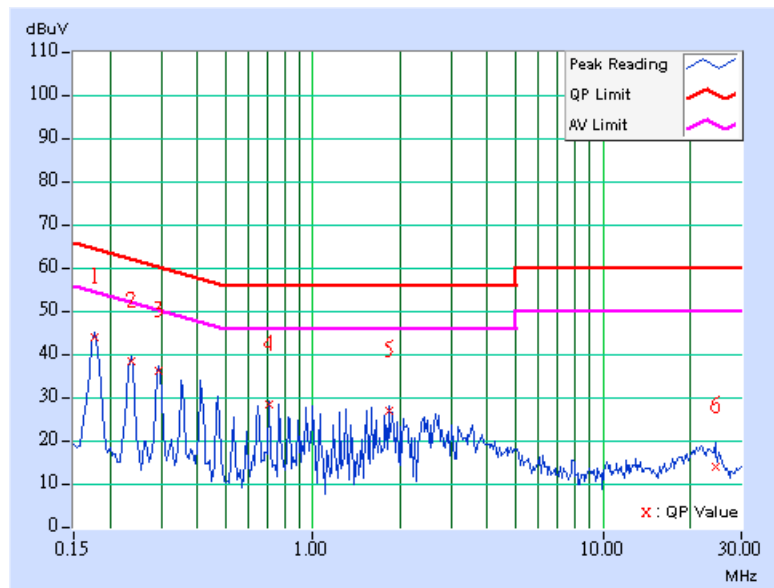

EUT TEST CONDITION		MEASUREMENT DETAIL	
CHANNEL	Channel 6	PHASE	Line 1
MODULATION TYPE	BPSK	6dB BANDWIDTH	9 kHz
TRANSFER RATE	6Mbps	INPUT POWER (SYSTEM)	120Vac, 60 Hz
ENVIRONMENTAL CONDITIONS	20deg. C, 60%RH, 991hPa	TEST MODE	A
TESTED BY	Match Tsui		

No	Freq. [MHz]	Corr. Factor [dB]	Reading Value [dB (uV)]		Emission Level [dB (uV)]		Limit [dB (uV)]		Margin (dB)	
			Q.P.	AV.	Q.P.	AV.	Q.P.	AV.	Q.P.	AV.
1	0.177	0.10	42.73	-	42.83	-	64.61	54.61	-21.78	-
2	0.236	0.10	37.76	-	37.86	-	62.24	52.24	-24.38	-
3	0.295	0.10	40.69	-	40.79	-	60.40	50.40	-19.61	-
4	0.705	0.11	26.67	-	26.78	-	56.00	46.00	-29.22	-
5	2.180	0.23	19.70	-	19.93	-	56.00	46.00	-36.07	-
6	22.941	0.72	15.31	-	16.03	-	60.00	50.00	-43.97	-

- REMARKS:**
1. Q.P. and AV. are abbreviations of quasi-peak and average individually.
 2. "-": The Quasi-peak reading value also meets average limit and measurement with the average detector is unnecessary.
 3. The emission levels of other frequencies were very low against the limit.
 4. Margin value = Emission level - Limit value
 5. Correction factor = Insertion loss + Cable loss
 6. Emission Level = Correction Factor + Reading Value.

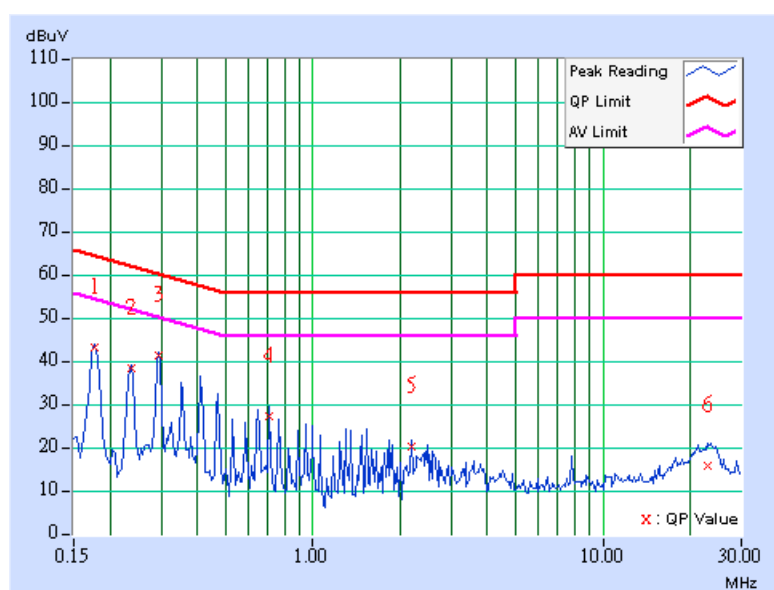

EUT TEST CONDITION		MEASUREMENT DETAIL	
CHANNEL	Channel 6	PHASE	Line 2
MODULATION TYPE	BPSK	6dB BANDWIDTH	9 kHz
TRANSFER RATE	6Mbps	INPUT POWER (SYSTEM)	120Vac, 60 Hz
ENVIRONMENTAL CONDITIONS	20deg. C, 60%RH, 991hPa	TEST MODE	A
TESTED BY	Match Tsui		

No	Freq. [MHz]	Corr. Factor [dB]	Reading Value [dB (uV)]		Emission Level [dB (uV)]		Limit [dB (uV)]		Margin (dB)	
			Q.P.	AV.	Q.P.	AV.	Q.P.	AV.	Q.P.	AV.
1	0.177	0.10	41.44	-	41.54	-	64.61	54.61	-23.07	-
2	0.236	0.10	36.07	-	36.17	-	62.24	52.24	-26.07	-
3	0.298	0.10	31.62	-	31.72	-	60.29	50.29	-28.57	-
4	0.709	0.16	27.68	-	27.84	-	56.00	46.00	-28.16	-
5	1.828	0.22	26.59	-	26.81	-	56.00	46.00	-29.19	-
6	24.445	0.70	14.44	-	15.14	-	60.00	50.00	-44.86	-

- REMARKS:**
1. Q.P. and AV. are abbreviations of quasi-peak and average individually.
 2. "-": The Quasi-peak reading value also meets average limit and measurement with the average detector is unnecessary.
 3. The emission levels of other frequencies were very low against the limit.
 4. Margin value = Emission level - Limit value
 5. Correction factor = Insertion loss + Cable loss
 6. Emission Level = Correction Factor + Reading Value.

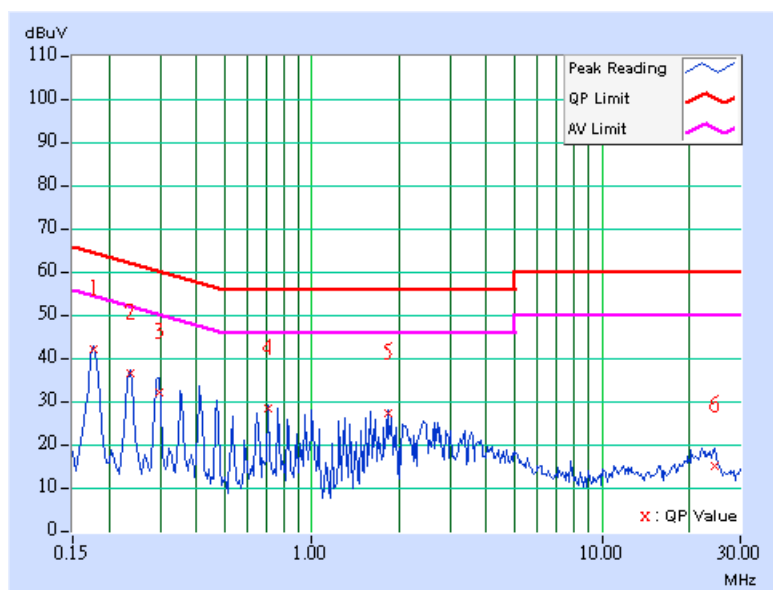

EUT TEST CONDITION		MEASUREMENT DETAIL	
CHANNEL	Channel 11	PHASE	Line 1
MODULATION TYPE	BPSK	6dB BANDWIDTH	9 kHz
TRANSFER RATE	6Mbps	INPUT POWER (SYSTEM)	120Vac, 60 Hz
ENVIRONMENTAL CONDITIONS	20deg. C, 60%RH, 991hPa	TEST MODE	A
TESTED BY	Match Tsui		

No	Freq. [MHz]	Corr. Factor [dB]	Reading Value [dB (uV)]		Emission Level [dB (uV)]		Limit [dB (uV)]		Margin (dB)	
			Q.P.	AV.	Q.P.	AV.	Q.P.	AV.	Q.P.	AV.
1	0.177	0.10	42.65	-	42.75	-	64.61	54.61	-21.86	-
2	0.236	0.10	37.62	-	37.72	-	62.24	52.24	-24.52	-
3	0.295	0.10	40.71	-	40.81	-	60.40	50.40	-19.59	-
4	0.707	0.11	26.59	-	26.70	-	56.00	46.00	-29.30	-
5	2.418	0.23	21.74	-	21.97	-	56.00	46.00	-34.03	-
6	22.707	0.71	15.38	-	16.09	-	60.00	50.00	-43.91	-

- REMARKS:**
1. Q.P. and AV. are abbreviations of quasi-peak and average individually.
 2. "-": The Quasi-peak reading value also meets average limit and measurement with the average detector is unnecessary.
 3. The emission levels of other frequencies were very low against the limit.
 4. Margin value = Emission level - Limit value
 5. Correction factor = Insertion loss + Cable loss
 6. Emission Level = Correction Factor + Reading Value.

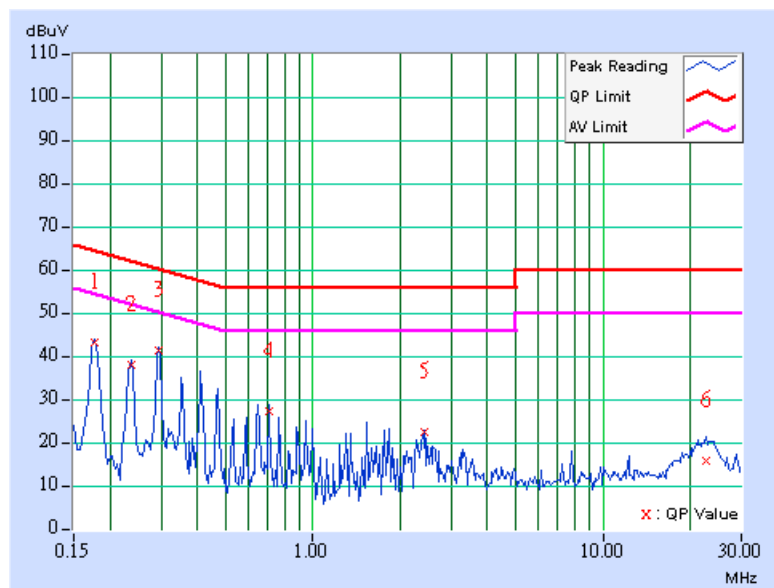

EUT TEST CONDITION		MEASUREMENT DETAIL	
CHANNEL	Channel 11	PHASE	Line 2
MODULATION TYPE	BPSK	6dB BANDWIDTH	9 kHz
TRANSFER RATE	6Mbps	INPUT POWER (SYSTEM)	120Vac, 60 Hz
ENVIRONMENTAL CONDITIONS	20deg. C, 60%RH, 991hPa	TEST MODE	A
TESTED BY	Match Tsui		

No	Freq. [MHz]	Corr. Factor [dB]	Reading Value [dB (uV)]		Emission Level [dB (uV)]		Limit [dB (uV)]		Margin (dB)	
			Q.P.	AV.	Q.P.	AV.	Q.P.	AV.	Q.P.	AV.
1	0.177	0.10	41.32	-	41.42	-	64.61	54.61	-23.19	-
2	0.236	0.10	35.99	-	36.09	-	62.24	52.24	-26.15	-
3	0.295	0.10	34.04	-	34.14	-	60.40	50.40	-26.26	-
4	1.004	0.21	26.65	-	26.86	-	56.00	46.00	-29.14	-
5	2.477	0.23	25.54	-	25.77	-	56.00	46.00	-30.23	-
6	24.828	0.71	10.92	-	11.63	-	60.00	50.00	-48.37	-

- REMARKS:**
1. Q.P. and AV. are abbreviations of quasi-peak and average individually.
 2. "-": The Quasi-peak reading value also meets average limit and measurement with the average detector is unnecessary.
 3. The emission levels of other frequencies were very low against the limit.
 4. Margin value = Emission level - Limit value
 5. Correction factor = Insertion loss + Cable loss
 6. Emission Level = Correction Factor + Reading Value.

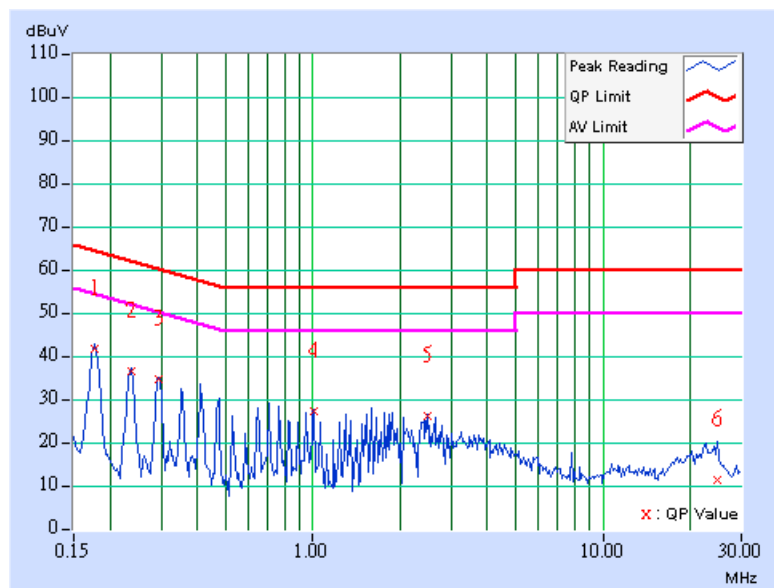

EUT TEST CONDITION		MEASUREMENT DETAIL	
CHANNEL	Channel 1	PHASE	Line 1
MODULATION TYPE	BPSK	6dB BANDWIDTH	9 kHz
TRANSFER RATE	6Mbps	INPUT POWER (SYSTEM)	120Vac, 60 Hz
ENVIRONMENTAL CONDITIONS	20deg. C, 65%RH, 991hPa	TEST MODE	B
TESTED BY	Lori Chiu		

No	Freq. [MHz]	Corr. Factor [dB]	Reading Value [dB (uV)]		Emission Level [dB (uV)]		Limit [dB (uV)]		Margin (dB)	
			Q.P.	AV.	Q.P.	AV.	Q.P.	AV.	Q.P.	AV.
1	0.162	0.10	51.56	-	51.66	-	65.38	55.38	-13.72	-
2	0.482	0.10	43.89	-	43.99	-	56.30	46.30	-12.31	-
3	0.642	0.10	40.17	-	40.27	-	56.00	46.00	-15.73	-
4	1.523	0.17	36.83	-	37.00	-	56.00	46.00	-19.00	-
5	12.156	0.39	34.44	-	34.83	-	60.00	50.00	-25.17	-
6	26.840	0.97	41.11	-	42.08	-	60.00	50.00	-17.92	-

- REMARKS:**
1. Q.P. and AV. are abbreviations of quasi-peak and average individually.
 2. "-": The Quasi-peak reading value also meets average limit and measurement with the average detector is unnecessary.
 3. The emission levels of other frequencies were very low against the limit.
 4. Margin value = Emission level - Limit value
 5. Correction factor = Insertion loss + Cable loss
 6. Emission Level = Correction Factor + Reading Value.

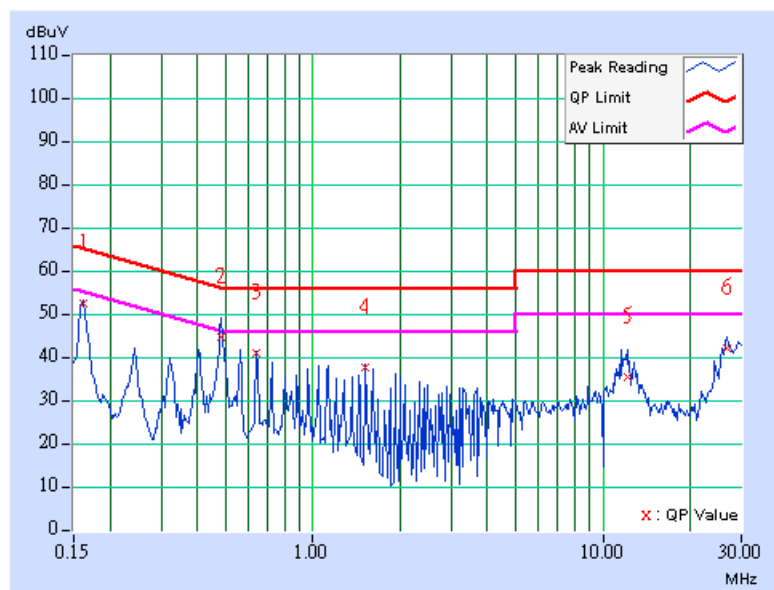

EUT TEST CONDITION		MEASUREMENT DETAIL	
CHANNEL	Channel 1	PHASE	Line 2
MODULATION TYPE	BPSK	6dB BANDWIDTH	9 kHz
TRANSFER RATE	6Mbps	INPUT POWER (SYSTEM)	120Vac, 60 Hz
ENVIRONMENTAL CONDITIONS	20deg. C, 65%RH, 991hPa	TEST MODE	B
TESTED BY	Lori Chiu		

No	Freq. [MHz]	Corr. Factor [dB]	Reading Value [dB (uV)]		Emission Level [dB (uV)]		Limit [dB (uV)]		Margin (dB)	
			Q.P.	AV.	Q.P.	AV.	Q.P.	AV.	Q.P.	AV.
1	0.162	0.10	51.89	-	51.99	-	65.38	55.38	-13.39	-
2	0.482	0.12	43.66	-	43.78	-	56.30	46.30	-12.53	-
3	0.560	0.13	40.50	-	40.63	-	56.00	46.00	-15.37	-
4	1.523	0.22	37.05	-	37.27	-	56.00	46.00	-18.73	-
5	11.754	0.45	37.80	-	38.25	-	60.00	50.00	-21.75	-
6	27.613	0.83	43.11	-	43.94	-	60.00	50.00	-16.06	-

- REMARKS:**
1. Q.P. and AV. are abbreviations of quasi-peak and average individually.
 2. "-": The Quasi-peak reading value also meets average limit and measurement with the average detector is unnecessary.
 3. The emission levels of other frequencies were very low against the limit.
 4. Margin value = Emission level - Limit value
 5. Correction factor = Insertion loss + Cable loss
 6. Emission Level = Correction Factor + Reading Value.

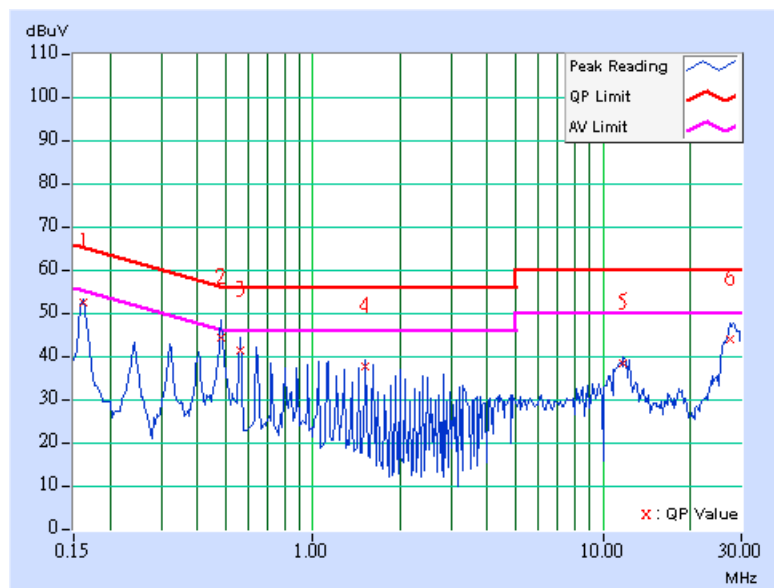

EUT TEST CONDITION		MEASUREMENT DETAIL	
CHANNEL	Channel 6	PHASE	Line 1
MODULATION TYPE	BPSK	6dB BANDWIDTH	9 kHz
TRANSFER RATE	6Mbps	INPUT POWER (SYSTEM)	120Vac, 60 Hz
ENVIRONMENTAL CONDITIONS	20deg. C, 65%RH, 991hPa	TEST MODE	B
TESTED BY	Lori Chiu		

No	Freq. [MHz]	Corr. Factor [dB]	Reading Value [dB (uV)]		Emission Level [dB (uV)]		Limit [dB (uV)]		Margin (dB)	
			Q.P.	AV.	Q.P.	AV.	Q.P.	AV.	Q.P.	AV.
1	0.162	0.10	51.61	-	51.71	-	65.38	55.38	-13.67	-
2	0.486	0.10	42.32	-	42.42	-	56.24	46.24	-13.82	-
3	0.642	0.10	40.19	-	40.29	-	56.00	46.00	-15.71	-
4	1.527	0.17	36.52	-	36.69	-	56.00	46.00	-19.31	-
5	11.762	0.38	36.78	-	37.16	-	60.00	50.00	-22.84	-
6	28.594	1.12	41.38	-	42.50	-	60.00	50.00	-17.50	-

- REMARKS:**
1. Q.P. and AV. are abbreviations of quasi-peak and average individually.
 2. "-": The Quasi-peak reading value also meets average limit and measurement with the average detector is unnecessary.
 3. The emission levels of other frequencies were very low against the limit.
 4. Margin value = Emission level - Limit value
 5. Correction factor = Insertion loss + Cable loss
 6. Emission Level = Correction Factor + Reading Value.

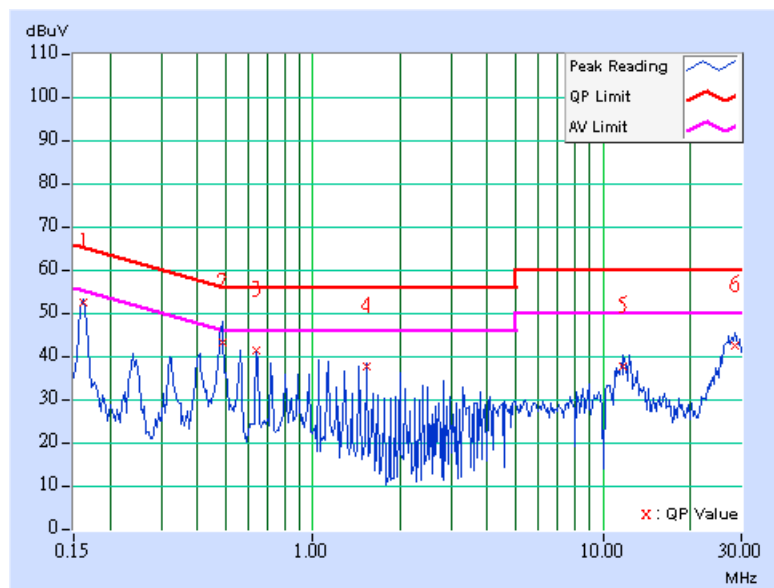

EUT TEST CONDITION		MEASUREMENT DETAIL	
CHANNEL	Channel 6	PHASE	Line 2
MODULATION TYPE	BPSK	6dB BANDWIDTH	9 kHz
TRANSFER RATE	6Mbps	INPUT POWER (SYSTEM)	120Vac, 60 Hz
ENVIRONMENTAL CONDITIONS	20deg. C, 65%RH, 991hPa	TEST MODE	B
TESTED BY	Lori Chiu		

No	Freq. [MHz]	Corr. Factor [dB]	Reading Value [dB (uV)]		Emission Level [dB (uV)]		Limit [dB (uV)]		Margin (dB)	
			Q.P.	AV.	Q.P.	AV.	Q.P.	AV.	Q.P.	AV.
1	0.162	0.10	52.10	-	52.20	-	65.38	55.38	-13.18	-
2	0.482	0.12	43.70	-	43.82	-	56.30	46.30	-12.49	-
3	0.560	0.13	40.53	-	40.66	-	56.00	46.00	-15.34	-
4	1.527	0.22	36.87	-	37.09	-	56.00	46.00	-18.91	-
5	11.559	0.45	36.40	-	36.85	-	60.00	50.00	-23.15	-
6	27.617	0.84	43.08	-	43.92	-	60.00	50.00	-16.08	-

- REMARKS:**
1. Q.P. and AV. are abbreviations of quasi-peak and average individually.
 2. "-": The Quasi-peak reading value also meets average limit and measurement with the average detector is unnecessary.
 3. The emission levels of other frequencies were very low against the limit.
 4. Margin value = Emission level - Limit value
 5. Correction factor = Insertion loss + Cable loss
 6. Emission Level = Correction Factor + Reading Value.

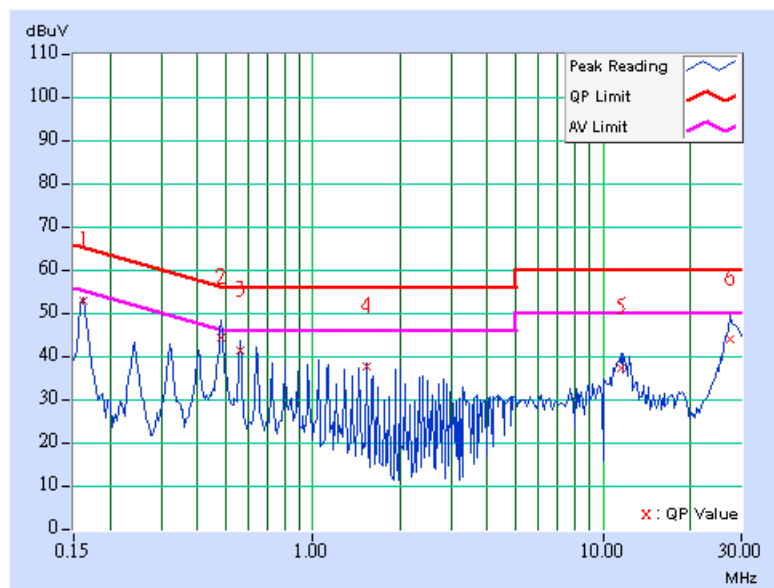

EUT TEST CONDITION		MEASUREMENT DETAIL	
CHANNEL	Channel 11	PHASE	Line 1
MODULATION TYPE	BPSK	6dB BANDWIDTH	9 kHz
TRANSFER RATE	6Mbps	INPUT POWER (SYSTEM)	120Vac, 60 Hz
ENVIRONMENTAL CONDITIONS	20deg. C, 65%RH, 991hPa	TEST MODE	B
TESTED BY	Lori Chiu		

No	Freq. [MHz]	Corr. Factor [dB]	Reading Value [dB (uV)]		Emission Level [dB (uV)]		Limit [dB (uV)]		Margin (dB)	
			Q.P.	AV.	Q.P.	AV.	Q.P.	AV.	Q.P.	AV.
1	0.162	0.10	51.61	-	51.71	-	65.38	55.38	-13.67	-
2	0.482	0.10	43.95	-	44.05	-	56.30	46.30	-12.25	-
3	0.642	0.10	40.23	-	40.33	-	56.00	46.00	-15.67	-
4	1.125	0.12	36.73	-	36.85	-	56.00	46.00	-19.15	-
5	11.766	0.38	30.24	-	30.62	-	60.00	50.00	-29.38	-
6	26.258	0.93	37.28	-	38.21	-	60.00	50.00	-21.79	-

- REMARKS:**
1. Q.P. and AV. are abbreviations of quasi-peak and average individually.
 2. "-": The Quasi-peak reading value also meets average limit and measurement with the average detector is unnecessary.
 3. The emission levels of other frequencies were very low against the limit.
 4. Margin value = Emission level - Limit value
 5. Correction factor = Insertion loss + Cable loss
 6. Emission Level = Correction Factor + Reading Value.

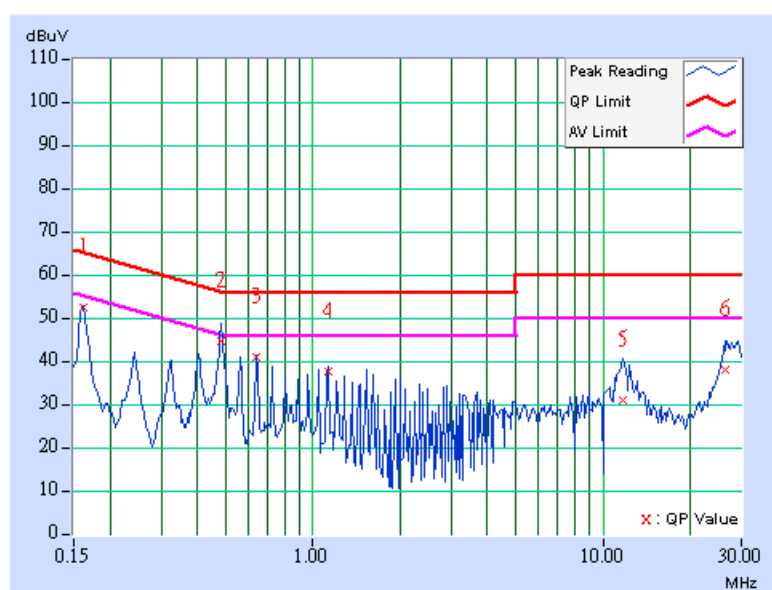

EUT TEST CONDITION		MEASUREMENT DETAIL	
CHANNEL	Channel 11	PHASE	Line 2
MODULATION TYPE	BPSK	6dB BANDWIDTH	9 kHz
TRANSFER RATE	6Mbps	INPUT POWER (SYSTEM)	120Vac, 60 Hz
ENVIRONMENTAL CONDITIONS	20deg. C, 65%RH, 991hPa	TEST MODE	B
TESTED BY	Lori Chiu		

No	Freq. [MHz]	Corr. Factor [dB]	Reading Value [dB (uV)]		Emission Level [dB (uV)]		Limit [dB (uV)]		Margin (dB)	
			Q.P.	AV.	Q.P.	AV.	Q.P.	AV.	Q.P.	AV.
1	0.162	0.10	51.75	-	51.85	-	65.38	55.38	-13.53	-
2	0.486	0.12	42.42	-	42.54	-	56.24	46.24	-13.70	-
3	0.564	0.13	40.60	-	40.73	-	56.00	46.00	-15.27	-
4	1.527	0.22	37.52	-	37.74	-	56.00	46.00	-18.26	-
5	11.762	0.45	38.53	-	38.98	-	60.00	50.00	-21.02	-
6	26.840	0.80	43.66	-	44.46	-	60.00	50.00	-15.54	-

- REMARKS:**
1. Q.P. and AV. are abbreviations of quasi-peak and average individually.
 2. "-": The Quasi-peak reading value also meets average limit and measurement with the average detector is unnecessary.
 3. The emission levels of other frequencies were very low against the limit.
 4. Margin value = Emission level - Limit value
 5. Correction factor = Insertion loss + Cable loss
 6. Emission Level = Correction Factor + Reading Value.

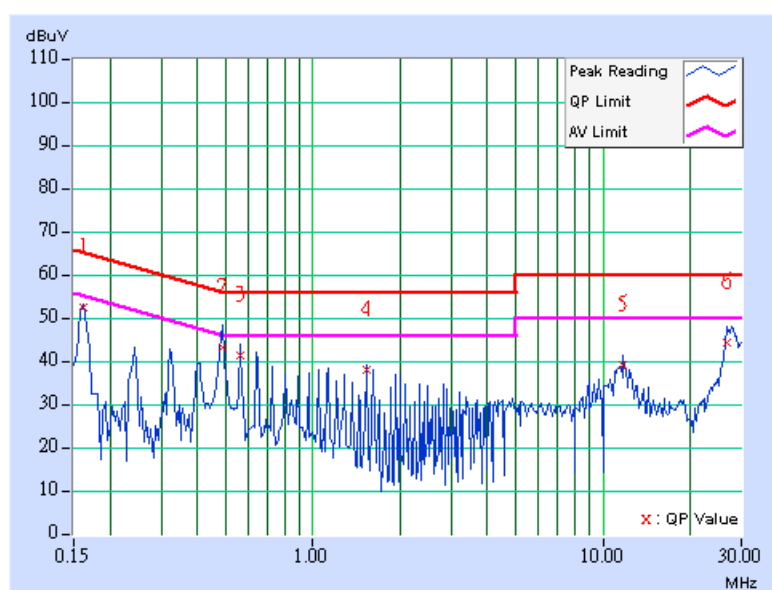

CONDUCTED WORST-CASE DATA_TURBO MODE

EUT TEST CONDITION		MEASUREMENT DETAIL	
CHANNEL	Channel 6	PHASE	Line 1
MODULATION TYPE	QPSK	6dB BANDWIDTH	9 kHz
TRANSFER RATE	12Mbps	INPUT POWER (SYSTEM)	120Vac, 60 Hz
ENVIRONMENTAL CONDITIONS	20deg. C, 60%RH, 1009hPa	TEST MODE	A
TESTED BY	Match Tsui		

No	Freq. [MHz]	Corr. Factor [dB]	Reading Value [dB (uV)]		Emission Level [dB (uV)]		Limit [dB (uV)]		Margin (dB)	
			Q.P.	AV.	Q.P.	AV.	Q.P.	AV.	Q.P.	AV.
1	0.179	0.10	43.54	-	43.64	-	64.55	54.55	-20.91	-
2	0.236	0.10	37.96	-	38.06	-	62.22	52.22	-24.16	-
3	0.295	0.10	40.93	-	41.03	-	60.40	50.40	-19.37	-
4	0.708	0.11	26.68	-	26.79	-	56.00	46.00	-29.21	-
5	2.419	0.23	21.41	-	21.64	-	56.00	46.00	-34.36	-
6	22.708	0.71	15.44	-	16.15	-	60.00	50.00	-43.85	-

- REMARKS:**
1. Q.P. and AV. are abbreviations of quasi-peak and average individually.
 2. "-": The Quasi-peak reading value also meets average limit and measurement with the average detector is unnecessary.
 3. The emission levels of other frequencies were very low against the limit.
 4. Margin value = Emission level - Limit value
 5. Correction factor = Insertion loss + Cable loss
 6. Emission Level = Correction Factor + Reading Value.

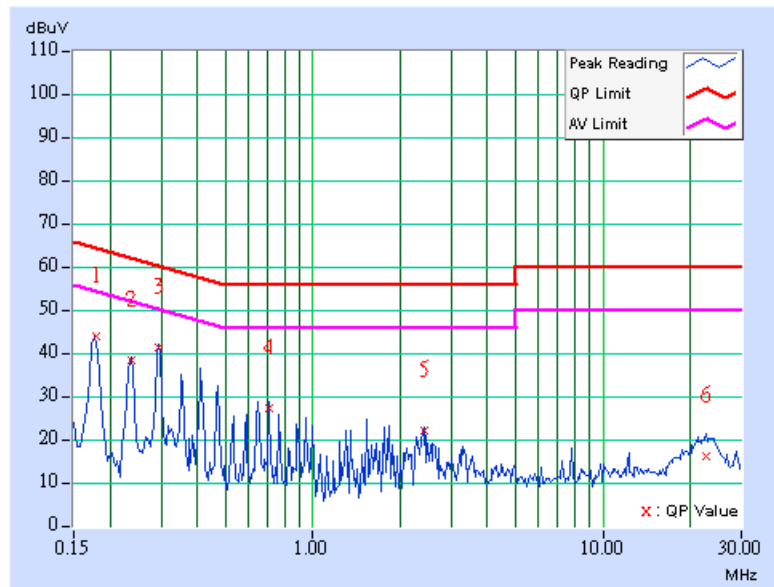

EUT TEST CONDITION		MEASUREMENT DETAIL	
CHANNEL	Channel 6	PHASE	Line 2
MODULATION TYPE	QPSK	6dB BANDWIDTH	9 kHz
TRANSFER RATE	12Mbps	INPUT POWER (SYSTEM)	120Vac, 60 Hz
ENVIRONMENTAL CONDITIONS	20deg. C, 60%RH, 1009hPa	TEST MODE	A
TESTED BY	Match Tsui		

No	Freq. [MHz]	Corr. Factor [dB]	Reading Value [dB (uV)]		Emission Level [dB (uV)]		Limit [dB (uV)]		Margin (dB)	
			Q.P.	AV.	Q.P.	AV.	Q.P.	AV.	Q.P.	AV.
1	0.178	0.10	43.57	-	43.67	-	64.60	54.60	-20.93	-
2	0.236	0.10	38.36	-	38.46	-	62.23	52.23	-23.77	-
3	0.295	0.10	35.66	-	35.76	-	60.40	50.40	-24.64	-
4	0.709	0.16	27.96	-	28.12	-	56.00	46.00	-27.88	-
5	1.830	0.22	26.51	-	26.73	-	56.00	46.00	-29.27	-
6	24.450	0.70	13.47	-	14.17	-	60.00	50.00	-45.83	-

- REMARKS:**
1. Q.P. and AV. are abbreviations of quasi-peak and average individually.
 2. "-": The Quasi-peak reading value also meets average limit and measurement with the average detector is unnecessary.
 3. The emission levels of other frequencies were very low against the limit.
 4. Margin value = Emission level - Limit value
 5. Correction factor = Insertion loss + Cable loss
 6. Emission Level = Correction Factor + Reading Value.

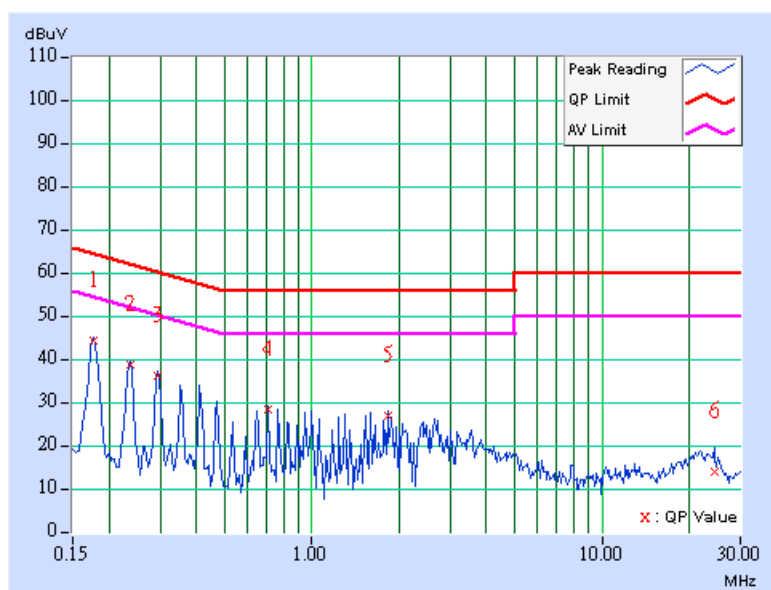

EUT TEST CONDITION		MEASUREMENT DETAIL	
CHANNEL	Channel 6	PHASE	Line 1
MODULATION TYPE	QPSK	6dB BANDWIDTH	9 kHz
TRANSFER RATE	12Mbps	INPUT POWER (SYSTEM)	120Vac, 60 Hz
ENVIRONMENTAL CONDITIONS	20deg. C, 60%RH, 1009hPa	TEST MODE	B
TESTED BY	Lori Chiu		

No	Freq. [MHz]	Corr. Factor [dB]	Reading Value [dB (uV)]		Emission Level [dB (uV)]		Limit [dB (uV)]		Margin (dB)	
			Q.P.	AV.	Q.P.	AV.	Q.P.	AV.	Q.P.	AV.
1	0.162	0.10	52.36	-	52.46	-	65.34	55.34	-12.88	-
2	0.482	0.10	43.89	-	43.99	-	56.30	46.30	-12.31	-
3	0.643	0.10	41.45	-	41.55	-	56.00	46.00	-14.45	-
4	1.524	0.17	36.83	-	37.00	-	56.00	46.00	-19.00	-
5	12.157	0.39	34.57	-	34.96	-	60.00	50.00	-25.04	-
6	26.840	0.97	41.51	-	42.48	-	60.00	50.00	-17.52	-

- REMARKS:**
1. Q.P. and AV. are abbreviations of quasi-peak and average individually.
 2. "-": The Quasi-peak reading value also meets average limit and measurement with the average detector is unnecessary.
 3. The emission levels of other frequencies were very low against the limit.
 4. Margin value = Emission level - Limit value
 5. Correction factor = Insertion loss + Cable loss
 6. Emission Level = Correction Factor + Reading Value.

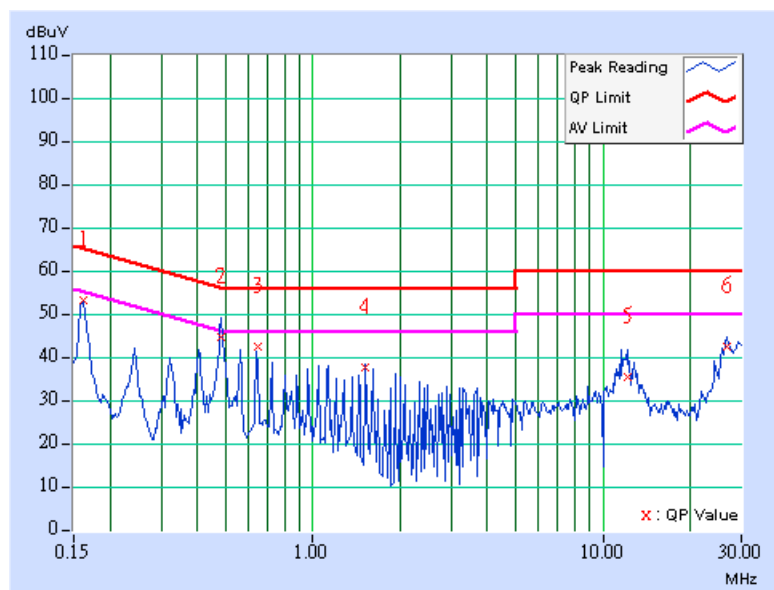

EUT TEST CONDITION		MEASUREMENT DETAIL	
CHANNEL	Channel 6	PHASE	Line 2
MODULATION TYPE	QPSK	6dB BANDWIDTH	9 kHz
TRANSFER RATE	12Mbps	INPUT POWER (SYSTEM)	120Vac, 60 Hz
ENVIRONMENTAL CONDITIONS	20deg. C, 60%RH, 1009hPa	TEST MODE	B
TESTED BY	Lori Chiu		

No	Freq. [MHz]	Corr. Factor [dB]	Reading Value [dB (uV)]		Emission Level [dB (uV)]		Limit [dB (uV)]		Margin (dB)	
			Q.P.	AV.	Q.P.	AV.	Q.P.	AV.	Q.P.	AV.
1	0.163	0.10	51.96	-	52.06	-	65.32	55.32	-13.26	-
2	0.486	0.12	42.63	-	42.75	-	56.23	46.23	-13.48	-
3	0.565	0.13	40.78	-	40.91	-	56.00	46.00	-15.09	-
4	1.529	0.22	37.77	-	37.99	-	56.00	46.00	-18.01	-
5	11.762	0.45	39.36	-	39.81	-	60.00	50.00	-20.19	-
6	26.840	0.80	43.74	-	44.54	-	60.00	50.00	-15.46	-

- REMARKS:**
1. Q.P. and AV. are abbreviations of quasi-peak and average individually.
 2. "-": The Quasi-peak reading value also meets average limit and measurement with the average detector is unnecessary.
 3. The emission levels of other frequencies were very low against the limit.
 4. Margin value = Emission level - Limit value
 5. Correction factor = Insertion loss + Cable loss
 6. Emission Level = Correction Factor + Reading Value.

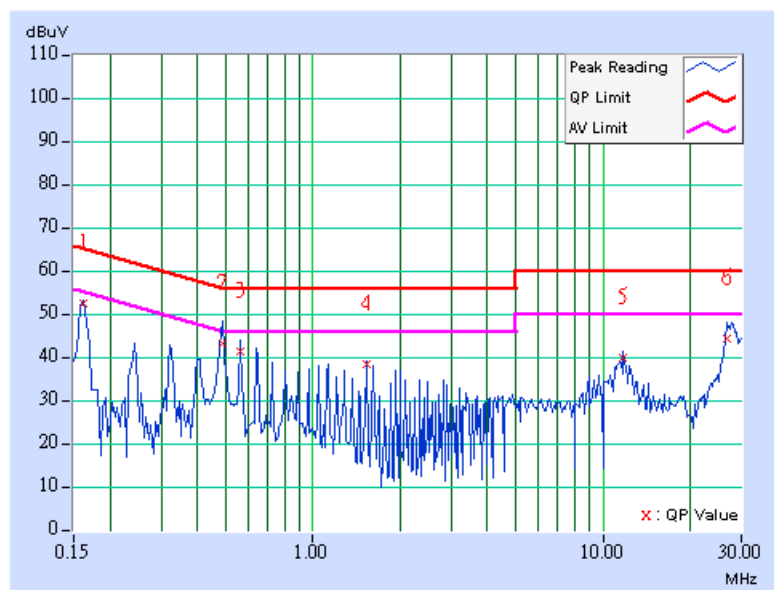



4.2 RADIATED EMISSION MEASUREMENT

4.2.1 LIMITS OF RADIATED EMISSION MEASUREMENT

Emissions radiated outside of the specified bands, shall be according to the general radiated limits in 15.209 as following:

Frequencies (MHz)	Field strength (microvolts/meter)	Measurement distance (meters)
0.009-0.490	2400/F(kHz)	300
0.490-1.705	24000/F(kHz)	30
1.705-30.0	30	30
30-88	100	3
88-216	150	3
216-960	200	3
Above 960	500	3

NOTE:

1. The lower limit shall apply at the transition frequencies.
2. Emission level (dBuV/m) = 20 log Emission level (uV/m).
3. As shown in 15.35(b), for frequencies above 1000MHz, the field strength limits are based on average detector, however, the peak field strength of any emission shall not exceed the maximum permitted average limits, specified above by more than 20dB under any condition of modulation.



4.2.2 TEST INSTRUMENTS

DESCRIPTION & MANUFACTURER	MODEL NO.	SERIAL NO.	CALIBRATED UNTIL
Test Receiver ROHDE & SCHWARZ	ESIB7	100188	Dec. 17, 2007
Spectrum Analyzer ROHDE & SCHWARZ	FSEK 30	100049	Aug. 21, 2007
BILOG Antenna SCHWARZBECK	VULB9168	9168-157	Jan. 04, 2008
HORN Antenna SCHWARZBECK	BBHA 9120 D	9120D-408	Jan. 18, 2008
HORN Antenna SCHWARZBECK	BBHA 9170	BBHA9170147	Jan. 16, 2008
Preamplifier Agilent	8449B	3008A01961	Oct. 15, 2007
Preamplifier Agilent	8447D	2944A10629	Oct. 16, 2007
RF signal cable HUBER+SUHNER	SUCOFLEX 106	25648/6	Dec. 19, 2007
RF signal cable HUBER+SUHNER	SUCOFLEX 104	251643/4	Dec. 11, 2007
Software ADT.	ADT_Radiated_V7.6	NA	NA
Antenna Tower ADT.	AT100	AT93021702	NA
Turn Table ADT.	TT100.	TT93021702	NA
Controller ADT.	SC100.	SC93021702	NA

- NOTE:**
1. The calibration interval of the above test instruments is 12 months and the calibrations are traceable to NML/ROC and NIST/USA.
 2. The test was performed in HwaYa Chamber 2.
 3. The horn antenna and HP preamplifier (model: 8449B) are used only for the measurement of emission frequency above 1GHz if tested.
 4. The IC Site Registration No. is IC3789B-2.

4.2.3 TEST PROCEDURES

- a. The EUT was placed on the top of a rotating table 0.8 meters above the ground at a 3 meters semi-anechoic chamber. The table was rotated 360 degrees to determine the position of the highest radiation.
- b. The EUT was set 3 meters away from the interference-receiving antenna, which was mounted on the top of a variable-height antenna tower.
- c. The antenna is a broadband antenna, and its height is varied from one meter to four meters above the ground to determine the maximum value of the field strength. Both horizontal and vertical polarizations of the antenna are set to make the measurement.
- d. For each suspected emission, the EUT was arranged to its worst case and then the antenna was tuned to heights from 1 meter to 4 meters and the rotatable table was turned from 0 degrees to 360 degrees to find the maximum reading.
- e. The test-receiver system was set to Peak Detect Function and Specified Bandwidth with Maximum Hold Mode.
- f. If the emission level of the EUT in peak mode was lower than the limit specified, then testing could be stopped and the peak values of the EUT would be reported. Otherwise the emissions would be re-tested one by one using peak, quasi-peak or average method as specified and then reported in a data sheet.

NOTE:

1. The resolution bandwidth and video bandwidth of test receiver/spectrum analyzer is 120kHz for Peak detection (PK) and Quasi-peak detection (QP) at frequency below 1GHz.
2. The resolution bandwidth of test receiver/spectrum analyzer is 1 MHz and video bandwidth is 3MHz for Peak detection at frequency above 1GHz.
3. The resolution bandwidth of test receiver/spectrum analyzer is 1MHz and the video bandwidth is 10Hz for Average detection (AV) at frequency above 1GHz.

4.2.4 DEVIATION FROM TEST STANDARD

No deviation

4.2.5 TEST SETUP

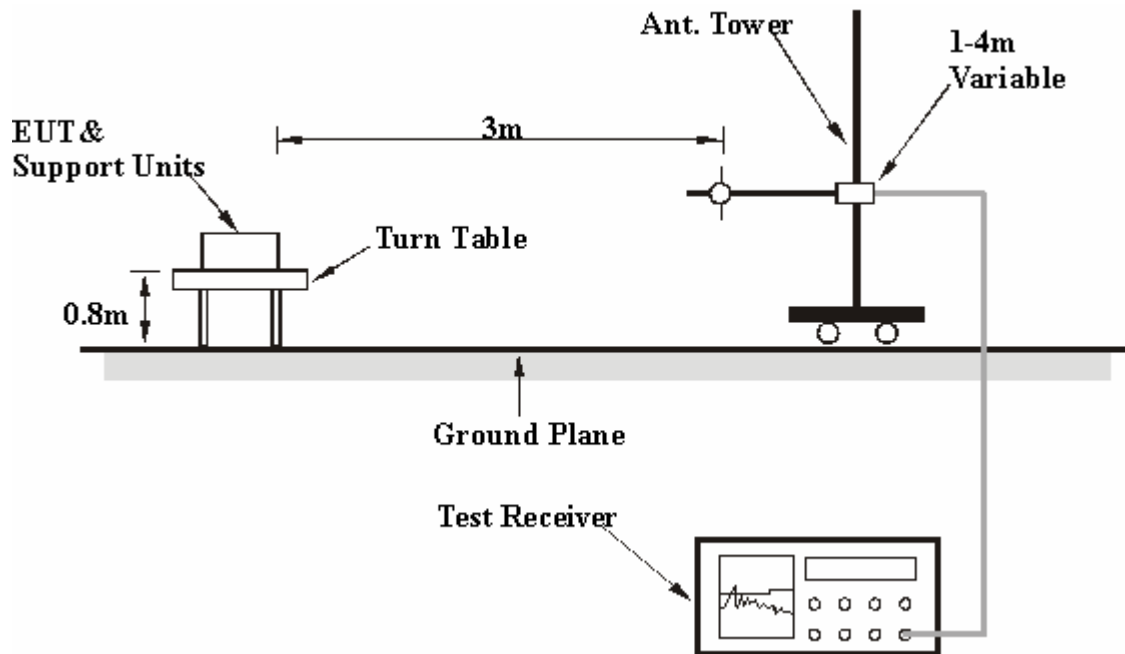

For the actual test configuration, please refer to the attached file (Test Setup Photo).

4.2.6 EUT OPERATING CONDITIONS

Same as 4.1.6.

4.2.7 TEST RESULTS

RADIATED WORST-CASE DATA: BELOW 1GHz_NORMAL MODE

EUT TEST CONDITION		MEASUREMENT DETAIL	
CHANNEL	Channel 11	FREQUENCY RANGE	Below 1000MHz
MODULATION TYPE	BPSK	DETECTOR FUNCTION	Quasi-Peak
TRANSFER RATE	6Mbps	INPUT POWER (SYSTEM)	120Vac, 60 Hz
ENVIRONMENTAL CONDITIONS	26deg. C, 65%RH, 991hPa	TEST MODE	A
TESTED BY	Lori Chiu		

ANTENNA POLARITY & TEST DISTANCE: HORIZONTAL AT 3 m								
No.	Freq. (MHz)	Emission Level (dBuV/m)	Limit (dBuV/m)	Margin (dB)	Antenna Height (m)	Table Angle (Degree)	Raw Value (dBuV)	Correction Factor (dB/m)
1	183.57	33.47 QP	43.50	-10.03	1.00 H	54	22.46	11.02
2	274.93	39.41 QP	46.00	-6.59	1.50 H	314	25.96	13.45
3	368.24	44.02 QP	46.00	-1.98	1.00 H	301	28.36	15.66
4	552.91	40.96 QP	46.00	-5.04	1.50 H	181	21.29	19.66
5	648.16	44.67 QP	46.00	-1.33	1.50 H	232	23.34	21.33
6	735.63	37.28 QP	46.00	-8.72	1.50 H	314	13.81	23.47
7	828.94	41.53 QP	46.00	-4.47	1.50 H	314	17.19	24.34
8	920.30	34.25 QP	46.00	-11.75	1.50 H	238	8.34	25.91

ANTENNA POLARITY & TEST DISTANCE: VERTICAL AT 3 m								
No.	Freq. (MHz)	Emission Level (dBuV/m)	Limit (dBuV/m)	Margin (dB)	Antenna Height (m)	Table Angle (Degree)	Raw Value (dBuV)	Correction Factor (dB/m)
1	49.44	28.17 QP	40.00	-11.83	1.00 V	200	14.29	13.88
2	183.57	32.03 QP	43.50	-11.47	1.00 V	10	21.01	11.02
3	274.93	43.31 QP	46.00	-2.69	1.00 V	137	29.87	13.45
4	368.24	40.96 QP	46.00	-5.04	1.00 V	10	25.30	15.66
5	552.91	35.44 QP	46.00	-10.56	1.50 V	130	15.78	19.66
6	648.16	42.94 QP	46.00	-3.06	2.00 V	187	21.60	21.33
7	828.94	36.51 QP	46.00	-9.49	1.00 V	137	12.17	24.34
8	906.69	43.46 QP	46.00	-2.54	1.00 V	187	18.20	25.25
9	910.58	39.59 QP	46.00	-6.41	1.00 V	314	14.15	25.44

- REMARKS:**
1. Emission level(dBuV/m)=Raw Value(dBuV) + Correction Factor(dB/m)
 2. Correction Factor(dB/m) = Antenna Factor (dB/m) + Cable Factor (dB)
 3. The other emission levels were very low against the limit.
 4. Margin value = Emission level – Limit value.



EUT TEST CONDITION		MEASUREMENT DETAIL	
CHANNEL	Channel 11	FREQUENCY RANGE	Below 1000MHz
MODULATION TYPE	BPSK	DETECTOR FUNCTION	Quasi-Peak
TRANSFER RATE	6Mbps	INPUT POWER (SYSTEM)	120Vac, 60 Hz
ENVIRONMENTAL CONDITIONS	24deg. C, 70%RH, 991hPa	TEST MODE	B
TESTED BY	Lori Chiu		

ANTENNA POLARITY & TEST DISTANCE: HORIZONTAL AT 3 m								
No.	Freq. (MHz)	Emission Level (dBuV/m)	Limit (dBuV/m)	Margin (dB)	Antenna Height (m)	Table Angle (Degree)	Raw Value (dBuV)	Correction Factor (dB/m)
1	94.06	37.34 QP	43.50	-6.16	2.00 H	88	28.27	9.07
2	103.78	41.91 QP	43.50	-1.59	2.00 H	268	32.30	9.60
3	249.60	42.67 QP	46.00	-3.33	1.00 H	190	30.14	12.54
4	325.43	41.36 QP	46.00	-4.64	1.00 H	199	27.39	13.97
5	799.84	39.37 QP	46.00	-6.63	1.50 H	82	15.01	24.36
6	933.99	40.34 QP	46.00	-5.66	1.00 H	238	14.74	25.60

ANTENNA POLARITY & TEST DISTANCE: VERTICAL AT 3 m								
No.	Freq. (MHz)	Emission Level (dBuV/m)	Limit (dBuV/m)	Margin (dB)	Antenna Height (m)	Table Angle (Degree)	Raw Value (dBuV)	Correction Factor (dB/m)
1	30.00	37.77 QP	40.00	-2.23	1.00 V	150	25.68	12.09
2	84.34	32.77 QP	40.00	-7.23	1.50 V	250	24.38	8.39
3	101.84	37.49 QP	43.50	-6.01	2.00 V	187	28.12	9.37
4	183.99	39.31 QP	43.50	-4.19	1.98 V	208	27.62	11.69
5	249.60	37.88 QP	46.00	-8.12	1.50 V	307	25.35	12.54
6	368.21	41.57 QP	46.00	-4.43	1.00 V	193	26.59	14.98
7	500.42	37.92 QP	46.00	-8.08	1.00 V	172	19.15	18.76
8	552.91	38.91 QP	46.00	-7.09	1.50 V	157	18.92	20.00

- REMARKS:**
1. Emission level(dBuV/m)=Raw Value(dBuV) + Correction Factor(dB/m)
 2. Correction Factor(dB/m) = Antenna Factor (dB/m) + Cable Factor (dB)
 3. The other emission levels were very low against the limit.
 4. Margin value = Emission level – Limit value.



RADIATED WORST-CASE DATA: BELOW 1GHz_TURBO MODE

EUT TEST CONDITION		MEASUREMENT DETAIL	
CHANNEL	Channel 6	FREQUENCY RANGE	Below 1000MHz
MODULATION TYPE	QPSK	DETECTOR FUNCTION	Quasi-Peak
TRANSFER RATE	12Mbps	INPUT POWER (SYSTEM)	120Vac, 60 Hz
ENVIRONMENTAL CONDITIONS	26deg. C, 65%RH, 1009hPa	TEST MODE	A
TESTED BY	Lori Chiu		

ANTENNA POLARITY & TEST DISTANCE: HORIZONTAL AT 3 m								
No.	Freq. (MHz)	Emission Level (dBuV/m)	Limit (dBuV/m)	Margin (dB)	Antenna Height (m)	Table Angle (Degree)	Raw Value (dBuV)	Correction Factor (dB/m)
1	274.88	38.96 QP	46.00	-7.04	1.00 H	124	26.01	12.95
2	368.21	44.81 QP	46.00	-1.19	1.00 H	139	29.83	14.98
3	459.59	40.79 QP	46.00	-5.21	1.00 H	142	23.28	17.51
4	500.42	36.87 QP	46.00	-9.13	1.50 H	118	18.11	18.76
5	552.91	42.64 QP	46.00	-3.36	1.50 H	130	22.65	20.00
6	624.85	36.12 QP	46.00	-9.88	1.50 H	40	14.80	21.32
7	916.50	39.72 QP	46.00	-6.28	1.00 H	136	14.26	25.45

ANTENNA POLARITY & TEST DISTANCE: VERTICAL AT 3 m								
No.	Freq. (MHz)	Emission Level (dBuV/m)	Limit (dBuV/m)	Margin (dB)	Antenna Height (m)	Table Angle (Degree)	Raw Value (dBuV)	Correction Factor (dB/m)
1	92.12	33.68 QP	43.50	-9.82	1.00 V	10	24.63	9.05
2	183.50	35.13 QP	43.50	-8.37	1.00 V	160	23.40	11.73
3	274.88	35.71 QP	46.00	-10.29	1.00 V	106	22.76	12.95
4	368.21	44.62 QP	46.00	-1.38	1.00 V	73	29.64	14.98
5	459.59	37.39 QP	46.00	-8.61	1.00 V	64	19.88	17.51
6	552.91	40.43 QP	46.00	-5.57	1.00 V	82	20.44	20.00
7	644.30	35.46 QP	46.00	-10.54	1.00 V	115	13.96	21.50

- REMARKS:**
1. Emission level(dBuV/m)=Raw Value(dBuV) + Correction Factor(dB/m)
 2. Correction Factor(dB/m) = Antenna Factor (dB/m) + Cable Factor (dB)
 3. The other emission levels were very low against the limit.
 4. Margin value = Emission level – Limit value.



EUT TEST CONDITION		MEASUREMENT DETAIL	
CHANNEL	Channel 6	FREQUENCY RANGE	Below 1000MHz
MODULATION TYPE	QPSK	DETECTOR FUNCTION	Quasi-Peak
TRANSFER RATE	12Mbps	INPUT POWER (SYSTEM)	120Vac, 60 Hz
ENVIRONMENTAL CONDITIONS	26deg. C, 65%RH, 1009hPa	TEST MODE	B
TESTED BY	Lori Chiu		

ANTENNA POLARITY & TEST DISTANCE: HORIZONTAL AT 3 m								
No.	Freq. (MHz)	Emission Level (dBuV/m)	Limit (dBuV/m)	Margin (dB)	Antenna Height (m)	Table Angle (Degree)	Raw Value (dBuV)	Correction Factor (dB/m)
1	274.88	39.18 QP	46.00	-6.82	1.00 H	124	26.24	12.95
2	368.21	44.48 QP	46.00	-1.52	1.00 H	139	29.50	14.98
3	449.87	30.27 QP	46.00	-15.73	1.00 H	133	13.06	17.21
4	459.59	40.36 QP	46.00	-5.64	1.00 H	136	22.85	17.51
5	500.42	30.43 QP	46.00	-15.57	1.00 H	148	11.67	18.76
6	552.91	38.04 QP	46.00	-7.96	1.00 H	127	18.04	20.00
7	644.30	35.40 QP	46.00	-10.60	1.00 H	43	13.90	21.50

ANTENNA POLARITY & TEST DISTANCE: VERTICAL AT 3 m								
No.	Freq. (MHz)	Emission Level (dBuV/m)	Limit (dBuV/m)	Margin (dB)	Antenna Height (m)	Table Angle (Degree)	Raw Value (dBuV)	Correction Factor (dB/m)
1	92.12	31.54 QP	43.50	-11.96	1.00 V	277	22.49	9.05
2	183.50	35.09 QP	43.50	-8.41	1.00 V	163	23.35	11.73
3	274.88	39.25 QP	46.00	-6.75	1.50 V	199	26.30	12.95
4	368.21	44.36 QP	46.00	-1.64	1.50 V	73	29.38	14.98
5	459.59	37.63 QP	46.00	-8.37	2.00 V	157	20.12	17.51
6	500.42	34.46 QP	46.00	-11.54	1.00 V	85	15.70	18.76
7	552.91	40.52 QP	46.00	-5.48	1.00 V	91	20.52	20.00
8	644.30	35.21 QP	46.00	-10.79	1.50 V	184	13.71	21.50

- REMARKS:**
1. Emission level(dBuV/m)=Raw Value(dBuV) + Correction Factor(dB/m)
 2. Correction Factor(dB/m) = Antenna Factor (dB/m) + Cable Factor (dB)
 3. The other emission levels were very low against the limit.
 4. Margin value = Emission level – Limit value.

802.11b DSSS MODULATION

EUT TEST CONDITION		MEASUREMENT DETAIL	
CHANNEL	Channel 1	FREQUENCY RANGE	1 ~ 25GHz
MODULATION TYPE	DBPSK	DETECTOR FUNCTION	Peak(PK) Average (AV)
TRANSFER RATE	1Mbps	ENVIRONMENTAL CONDITIONS	28deg. C, 63%RH, 991hPa
INPUT POWER (SYSTEM)	120Vac, 60 Hz	TESTED BY	Lori Chiu

ANTENNA POLARITY & TEST DISTANCE: HORIZONTAL AT 3 m								
No.	Freq. (MHz)	Emission Level (dBuV/m)	Limit (dBuV/m)	Margin (dB)	Antenna Height (m)	Table Angle (Degree)	Raw Value (dBuV)	Correction Factor (dB/m)
1	1608.00	43.56 PK	74.00	-30.44	1.36 H	186	14.82	28.74
2	1608.00	37.45 AV	54.00	-16.55	1.36 H	186	8.71	28.74
3	2386.00	60.76 PK	74.00	-13.24	1.07 H	128	29.39	31.37
4	2386.00	52.20 AV	54.00	-1.80	1.07 H	128	20.83	31.37
5	*2412.00	110.80 PK			1.07 H	156	79.34	31.46
6	*2412.00	106.34 AV			1.07 H	156	74.88	31.46
7	4824.00	50.81 PK	74.00	-23.19	1.39 H	19	13.68	37.13
8	4824.00	43.09 AV	54.00	-10.91	1.39 H	19	5.96	37.13

ANTENNA POLARITY & TEST DISTANCE: VERTICAL AT 3 m								
No.	Freq. (MHz)	Emission Level (dBuV/m)	Limit (dBuV/m)	Margin (dB)	Antenna Height (m)	Table Angle (Degree)	Raw Value (dBuV)	Correction Factor (dB/m)
1	2386.00	58.36 PK	74.00	-15.64	1.37 V	205	26.99	31.37
2	2386.00	48.59 AV	54.00	-5.41	1.37 V	205	17.22	31.37
3	*2412.00	108.95 PK			1.14 V	206	77.49	31.46
4	*2412.00	104.69 AV			1.14 V	206	73.23	31.46
5	4824.00	49.93 PK	74.00	-24.07	1.08 V	127	12.80	37.13
6	4824.00	42.38 AV	54.00	-11.62	1.08 V	127	5.25	37.13

- REMARKS:**
1. Emission level(dBuV/m)=Raw Value(dBuV) + Correction Factor(dB/m)
 2. Correction Factor(dB/m) = Antenna Factor (dB/m) + Cable Factor (dB)
 3. The other emission levels were very low against the limit.
 4. Margin value = Emission level – Limit value.
 5. “ * “ : Fundamental frequency.



EUT TEST CONDITION		MEASUREMENT DETAIL	
CHANNEL	Channel 6	FREQUENCY RANGE	1 ~ 25GHz
MODULATION TYPE	DBPSK	DETECTOR FUNCTION	Peak(PK) Average (AV)
TRANSFER RATE	1Mbps	ENVIRONMENTAL CONDITIONS	25deg. C, 66%RH, 991hPa
INPUT POWER (SYSTEM)	120Vac, 60 Hz	TESTED BY	Lori Chiu

ANTENNA POLARITY & TEST DISTANCE: HORIZONTAL AT 3 m								
No.	Freq. (MHz)	Emission Level (dBuV/m)	Limit (dBuV/m)	Margin (dB)	Antenna Height (m)	Table Angle (Degree)	Raw Value (dBuV)	Correction Factor (dB/m)
1	1624.00	43.05 PK	74.00	-30.95	1.28 H	175	14.26	28.79
2	1624.00	37.24 AV	54.00	-16.76	1.28 H	175	8.45	28.79
3	*2437.00	110.36 PK			1.05 H	315	78.82	31.54
4	*2437.00	105.43 AV			1.05 H	315	73.89	31.54
5	4874.00	50.54 PK	74.00	-23.46	1.15 H	272	13.25	37.29
6	4874.00	43.02 AV	54.00	-10.98	1.15 H	272	5.73	37.29

ANTENNA POLARITY & TEST DISTANCE: VERTICAL AT 3 m								
No.	Freq. (MHz)	Emission Level (dBuV/m)	Limit (dBuV/m)	Margin (dB)	Antenna Height (m)	Table Angle (Degree)	Raw Value (dBuV)	Correction Factor (dB/m)
1	*2437.00	108.78 PK			1.34 V	329	77.24	31.54
2	*2437.00	104.50 AV			1.34 V	329	72.96	31.54
3	4874.00	48.22 PK	74.00	-25.78	1.00 V	224	10.93	37.29
4	4874.00	41.57 AV	54.00	-12.43	1.00 V	224	4.28	37.29

- REMARKS:**
1. Emission level(dBuV/m)=Raw Value(dBuV) + Correction Factor(dB/m)
 2. Correction Factor(dB/m) = Antenna Factor (dB/m) + Cable Factor (dB)
 3. The other emission levels were very low against the limit.
 4. Margin value = Emission level – Limit value.
 5. “ * “ : Fundamental frequency.



EUT TEST CONDITION		MEASUREMENT DETAIL	
CHANNEL	Channel 11	FREQUENCY RANGE	1 ~ 25GHz
MODULATION TYPE	DBPSK	DETECTOR FUNCTION	Peak(PK) Average (AV)
TRANSFER RATE	1Mbps	ENVIRONMENTAL CONDITIONS	25deg. C, 66%RH, 991hPa
INPUT POWER (SYSTEM)	120Vac, 60 Hz	TESTED BY	Lori Chiu

ANTENNA POLARITY & TEST DISTANCE: HORIZONTAL AT 3 m								
No.	Freq. (MHz)	Emission Level (dBuV/m)	Limit (dBuV/m)	Margin (dB)	Antenna Height (m)	Table Angle (Degree)	Raw Value (dBuV)	Correction Factor (dB/m)
1	1641.00	43.66 PK	74.00	-30.34	1.33 H	122	14.81	28.85
2	1641.00	37.73 AV	54.00	-16.27	1.33 H	122	8.88	28.85
3	*2462.00	110.65 PK			1.05 H	316	79.03	31.62
4	*2462.00	105.05 AV			1.05 H	316	73.43	31.62
5	2487.00	61.33 PK	74.00	-12.67	1.02 H	316	29.62	31.71
6	2487.00	52.64 AV	54.00	-1.36	1.02 H	316	20.93	31.71
7	4924.00	50.94 PK	74.00	-23.06	1.06 H	195	13.50	37.44
8	4924.00	43.18 AV	54.00	-10.82	1.06 H	195	5.74	37.44

ANTENNA POLARITY & TEST DISTANCE: VERTICAL AT 3 m								
No.	Freq. (MHz)	Emission Level (dBuV/m)	Limit (dBuV/m)	Margin (dB)	Antenna Height (m)	Table Angle (Degree)	Raw Value (dBuV)	Correction Factor (dB/m)
1	*2462.00	108.72 PK			1.12 V	238	77.10	31.62
2	*2462.00	104.38 AV			1.12 V	238	72.76	31.62
3	2487.00	58.13 PK	74.00	-15.87	1.13 V	242	26.42	31.71
4	2487.00	48.60 AV	54.00	-5.40	1.13 V	242	16.89	31.71
5	4924.00	48.10 PK	74.00	-25.90	1.20 V	217	10.66	37.44
6	4924.00	41.62 AV	54.00	-12.38	1.20 V	217	4.18	37.44

- REMARKS:**
1. Emission level(dBuV/m)=Raw Value(dBuV) + Correction Factor(dB/m)
 2. Correction Factor(dB/m) = Antenna Factor (dB/m) + Cable Factor (dB)
 3. The other emission levels were very low against the limit.
 4. Margin value = Emission level – Limit value.
 5. “ * “ : Fundamental frequency.



802.11g OFDM MODULATION_NORMAL MODE

EUT TEST CONDITION		MEASUREMENT DETAIL	
CHANNEL	Channel 1	FREQUENCY RANGE	1 ~ 25GHz
MODULATION TYPE	BPSK	DETECTOR FUNCTION	Peak(PK) Average (AV)
TRANSFER RATE	6Mbps	ENVIRONMENTAL CONDITIONS	28deg. C, 63%RH, 991hPa
INPUT POWER (SYSTEM)	120Vac, 60 Hz	TESTED BY	Lori Chiu

ANTENNA POLARITY & TEST DISTANCE: HORIZONTAL AT 3 m								
No.	Freq. (MHz)	Emission Level (dBuV/m)	Limit (dBuV/m)	Margin (dB)	Antenna Height (m)	Table Angle (Degree)	Raw Value (dBuV)	Correction Factor (dB/m)
1	1608.00	42.70 PK	74.00	-31.30	1.69 H	108	13.96	28.74
2	1608.00	36.86 AV	54.00	-17.14	1.69 H	108	8.12	28.74
3	2390.00	70.58 PK	74.00	-3.42	1.33 H	138	39.19	31.39
4	2390.00	52.05 AV	54.00	-1.95	1.33 H	138	20.66	31.39
5	*2412.00	109.32 PK			1.06 H	157	77.86	31.46
6	*2412.00	99.09 AV			1.06 H	157	67.63	31.46
7	4824.00	47.12 PK	74.00	-26.88	1.33 H	326	9.99	37.13
8	4824.00	33.52 AV	54.00	-20.48	1.33 H	326	-3.61	37.13

ANTENNA POLARITY & TEST DISTANCE: VERTICAL AT 3 m								
No.	Freq. (MHz)	Emission Level (dBuV/m)	Limit (dBuV/m)	Margin (dB)	Antenna Height (m)	Table Angle (Degree)	Raw Value (dBuV)	Correction Factor (dB/m)
1	1608.00	42.08 PK	74.00	-31.92	1.21 V	27	13.34	28.74
2	1608.00	35.49 AV	54.00	-18.51	1.21 V	27	6.75	28.74
3	2390.00	70.96 PK	74.00	-3.04	1.20 V	147	39.57	31.39
4	2390.00	48.81 AV	54.00	-5.19	1.20 V	147	17.42	31.39
5	*2412.00	107.99 PK			1.19 V	118	76.53	31.46
6	*2412.00	97.87 AV			1.19 V	118	66.41	31.46
7	4824.00	47.93 PK	74.00	-26.07	1.36 V	279	10.80	37.13
8	4824.00	33.78 AV	54.00	-20.22	1.36 V	279	-3.35	37.13

- REMARKS:**
1. Emission level(dBuV/m)=Raw Value(dBuV) + Correction Factor(dB/m)
 2. Correction Factor(dB/m) = Antenna Factor (dB/m) + Cable Factor (dB)
 3. The other emission levels were very low against the limit.
 4. Margin value = Emission level – Limit value.
 5. “ * “ : Fundamental frequency.

EUT TEST CONDITION		MEASUREMENT DETAIL	
CHANNEL	Channel 6	FREQUENCY RANGE	1 ~ 25GHz
MODULATION TYPE	BPSK	DETECTOR FUNCTION	Peak(PK) Average (AV)
TRANSFER RATE	6Mbps	ENVIRONMENTAL CONDITIONS	28deg. C, 63%RH, 991hPa
INPUT POWER (SYSTEM)	120Vac, 60 Hz	TESTED BY	Lori Chiu

ANTENNA POLARITY & TEST DISTANCE: HORIZONTAL AT 3 m								
No.	Freq. (MHz)	Emission Level (dBuV/m)	Limit (dBuV/m)	Margin (dB)	Antenna Height (m)	Table Angle (Degree)	Raw Value (dBuV)	Correction Factor (dB/m)
1	1624.00	43.35 PK	74.00	-30.65	1.33 H	110	14.56	28.79
2	1624.00	37.94 AV	54.00	-16.06	1.33 H	110	9.15	28.79
3	*2437.00	111.50 PK			1.07 H	136	79.96	31.54
4	*2437.00	100.17 AV			1.07 H	136	68.63	31.54
5	4874.00	47.70 PK	74.00	-26.30	1.02 H	156	10.41	37.29
6	4874.00	33.07 AV	54.00	-20.93	1.02 H	156	-4.22	37.29

ANTENNA POLARITY & TEST DISTANCE: VERTICAL AT 3 m								
No.	Freq. (MHz)	Emission Level (dBuV/m)	Limit (dBuV/m)	Margin (dB)	Antenna Height (m)	Table Angle (Degree)	Raw Value (dBuV)	Correction Factor (dB/m)
1	1624.00	42.23 PK	74.00	-31.77	1.32 V	166	13.44	28.79
2	1624.00	36.14 AV	54.00	-17.86	1.32 V	166	7.35	28.79
3	*2437.00	110.26 PK			1.16 V	120	78.72	31.54
4	*2437.00	99.47 AV			1.16 V	120	67.93	31.54
5	4874.00	47.52 PK	74.00	-26.48	1.00 V	56	10.23	37.29
6	4874.00	33.00 AV	54.00	-21.00	1.00 V	56	-4.29	37.29

- REMARKS:**
1. Emission level(dBuV/m)=Raw Value(dBuV) + Correction Factor(dB/m)
 2. Correction Factor(dB/m) = Antenna Factor (dB/m) + Cable Factor (dB)
 3. The other emission levels were very low against the limit.
 4. Margin value = Emission level – Limit value.
 5. “ * “ : Fundamental frequency.



EUT TEST CONDITION		MEASUREMENT DETAIL	
CHANNEL	Channel 11	FREQUENCY RANGE	1 ~ 25GHz
MODULATION TYPE	BPSK	DETECTOR FUNCTION	Peak(PK) Average (AV)
TRANSFER RATE	6Mbps	ENVIRONMENTAL CONDITIONS	28deg. C, 63%RH, 991hPa
INPUT POWER (SYSTEM)	120Vac, 60 Hz	TESTED BY	Lori Chiu

ANTENNA POLARITY & TEST DISTANCE: HORIZONTAL AT 3 m								
No.	Freq. (MHz)	Emission Level (dBuV/m)	Limit (dBuV/m)	Margin (dB)	Antenna Height (m)	Table Angle (Degree)	Raw Value (dBuV)	Correction Factor (dB/m)
1	1641.00	41.29 PK	74.00	-32.71	1.13 H	97	12.44	28.85
2	1641.00	36.71 AV	54.00	-17.29	1.13 H	97	7.86	28.85
3	*2462.00	108.88 PK			1.29 H	166	77.26	31.62
4	*2462.00	98.32 AV			1.29 H	166	66.70	31.62
5	2483.50	71.71 PK	74.00	-2.29	1.03 H	137	40.01	31.70
6	2483.50	52.54 AV	54.00	-1.46	1.03 H	137	20.84	31.70
7	4924.00	46.72 PK	74.00	-27.28	1.13 H	242	9.28	37.44
8	4924.00	33.46 AV	54.00	-20.54	1.13 H	242	-3.98	37.44

ANTENNA POLARITY & TEST DISTANCE: VERTICAL AT 3 m								
No.	Freq. (MHz)	Emission Level (dBuV/m)	Limit (dBuV/m)	Margin (dB)	Antenna Height (m)	Table Angle (Degree)	Raw Value (dBuV)	Correction Factor (dB/m)
1	1641.00	41.06 PK	74.00	-32.94	1.28 V	33	12.21	28.85
2	1641.00	35.68 AV	54.00	-18.32	1.28 V	33	6.83	28.85
3	*2462.00	107.17 PK			1.13 V	121	75.55	31.62
4	*2462.00	97.50 AV			1.13 V	121	65.88	31.62
5	2483.50	71.75 PK	74.00	-2.25	1.14 V	118	40.05	31.70
6	2483.50	50.82 AV	54.00	-3.18	1.14 V	118	19.12	31.70
7	4924.00	46.68 PK	74.00	-27.32	1.00 V	125	9.24	37.44
8	4924.00	33.34 AV	54.00	-20.66	1.00 V	125	-4.10	37.44

- REMARKS:**
1. Emission level(dBuV/m)=Raw Value(dBuV) + Correction Factor(dB/m)
 2. Correction Factor(dB/m) = Antenna Factor (dB/m) + Cable Factor (dB)
 3. The other emission levels were very low against the limit.
 4. Margin value = Emission level – Limit value.
 5. “ * “ : Fundamental frequency.



802.11g OFDM MODULATION_TURBO MODE

EUT TEST CONDITION		MEASUREMENT DETAIL	
CHANNEL	Channel 6	FREQUENCY RANGE	1 ~ 25GHz
MODULATION TYPE	QPSK	DETECTOR FUNCTION	Peak(PK) Average (AV)
TRANSFER RATE	12Mbps	ENVIRONMENTAL CONDITIONS	26deg. C, 65%RH, 1009hPa
INPUT POWER (SYSTEM)	120Vac, 60 Hz	TESTED BY	Lori Chiu

ANTENNA POLARITY & TEST DISTANCE: HORIZONTAL AT 3 m

No.	Freq. (MHz)	Emission Level (dBuV/m)	Limit (dBuV/m)	Margin (dB)	Antenna Height (m)	Table Angle (Degree)	Raw Value (dBuV)	Correction Factor (dB/m)
1	1624.00	44.67 PK	74.00	-29.33	1.00 H	167	16.93	27.74
2	1624.00	38.43 AV	54.00	-15.57	1.00 H	167	10.69	27.74
3	2390.00	62.89 PK	74.00	-11.11	1.11 H	221	31.67	31.22
4	2390.00	51.76 AV	54.00	-2.24	1.11 H	221	20.54	31.22
5	*2437.00	108.12 PK			1.10 H	213	76.90	31.22
6	*2437.00	97.67 AV			1.10 H	213	66.45	31.22
7	2483.50	61.74 PK	74.00	-12.26	1.10 H	216	30.50	31.24
8	2483.50	50.37 AV	54.00	-3.63	1.10 H	216	19.13	31.24
9	4874.00	49.47 PK	74.00	-24.53	1.43 H	354	12.89	36.58
10	4874.00	35.61 AV	54.00	-18.39	1.43 H	354	-0.97	36.58

ANTENNA POLARITY & TEST DISTANCE: VERTICAL AT 3 m

No.	Freq. (MHz)	Emission Level (dBuV/m)	Limit (dBuV/m)	Margin (dB)	Antenna Height (m)	Table Angle (Degree)	Raw Value (dBuV)	Correction Factor (dB/m)
1	2390.00	57.55 PK	74.00	-16.45	1.00 V	156	26.33	31.22
2	2390.00	46.86 AV	54.00	-7.14	1.00 V	156	15.64	31.22
3	*2437.00	106.59 PK			1.00 V	155	75.37	31.22
4	*2437.00	96.20 AV			1.00 V	155	64.98	31.22
5	2483.50	56.12 PK	74.00	-17.88	1.01 V	155	24.88	31.24
6	2483.50	45.53 AV	54.00	-8.47	1.01 V	155	14.29	31.24
7	4874.00	48.64 PK	74.00	-25.36	1.13 V	206	12.06	36.58
8	4874.00	34.41 AV	54.00	-19.59	1.13 V	206	-2.17	36.58

- REMARKS:**
1. Emission level(dBuV/m)=Raw Value(dBuV) + Correction Factor(dB/m)
 2. Correction Factor(dB/m) = Antenna Factor (dB/m) + Cable Factor (dB)
 3. The other emission levels were very low against the limit.
 4. Margin value = Emission level – Limit value.
 5. " * " : Fundamental frequency.



4.3 6dB BANDWIDTH MEASUREMENT

4.3.1 LIMITS OF 6dB BANDWIDTH MEASUREMENT

The minimum of 6dB Bandwidth Measurement is 0.5 MHz.

4.3.2 TEST INSTRUMENTS

DESCRIPTION & MANUFACTURER	MODEL NO.	SERIAL NO.	CALIBRATED UNTIL
SPECTRUM ANALYZER	FSP40	100040	Jun. 07, 2007

NOTE: The calibration interval of the above test instruments is 12 months and the calibrations are traceable to NML/ROC and NIST/USA.

4.3.3 TEST PROCEDURE

The transmitter output was connected to the spectrum analyzer through an attenuator. The bandwidth of the fundamental frequency was measured by spectrum analyzer with 100 kHz RBW and 100kHz VBW. The 6dB bandwidth is defined as the total spectrum the power of which is higher than peak power minus 6dB.

4.3.4 DEVIATION FROM TEST STANDARD

No deviation

4.3.5 TEST SETUP



For the actual test configuration, please refer to the related Item – Photographs of the Test Configuration.

4.3.6 EUT OPERATING CONDITIONS

The software provided by client to enable the EUT under transmission condition continuously at lowest, middle and highest channel frequencies individually.



4.3.7 TEST RESULTS

802.11b DSSS MODULATION

MODULATION TYPE	DBPSK	TRANSFER RATE	1Mbps
INPUT POWER (SYSTEM)	120Vac, 60 Hz	ENVIRONMENTAL CONDITIONS	23deg.C, 60%RH, 991hPa
TESTED BY	Match Tsui		

CHANNEL	CHANNEL FREQUENCY (MHz)	6dB BANDWIDTH (MHz)	MINIMUM LIMIT (MHz)	PASS/FAIL
1	2412	11.12	0.5	PASS
6	2437	11.12	0.5	PASS
11	2462	11.08	0.5	PASS



CH 1

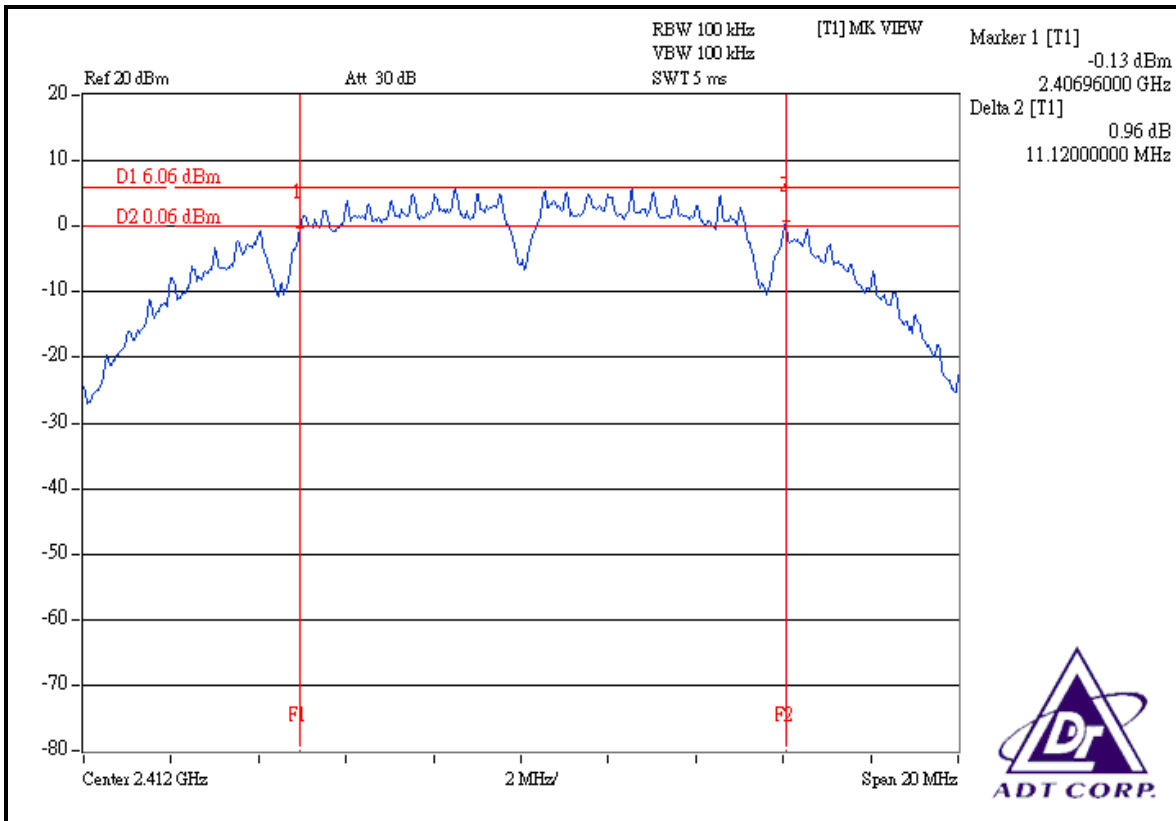

CH 6

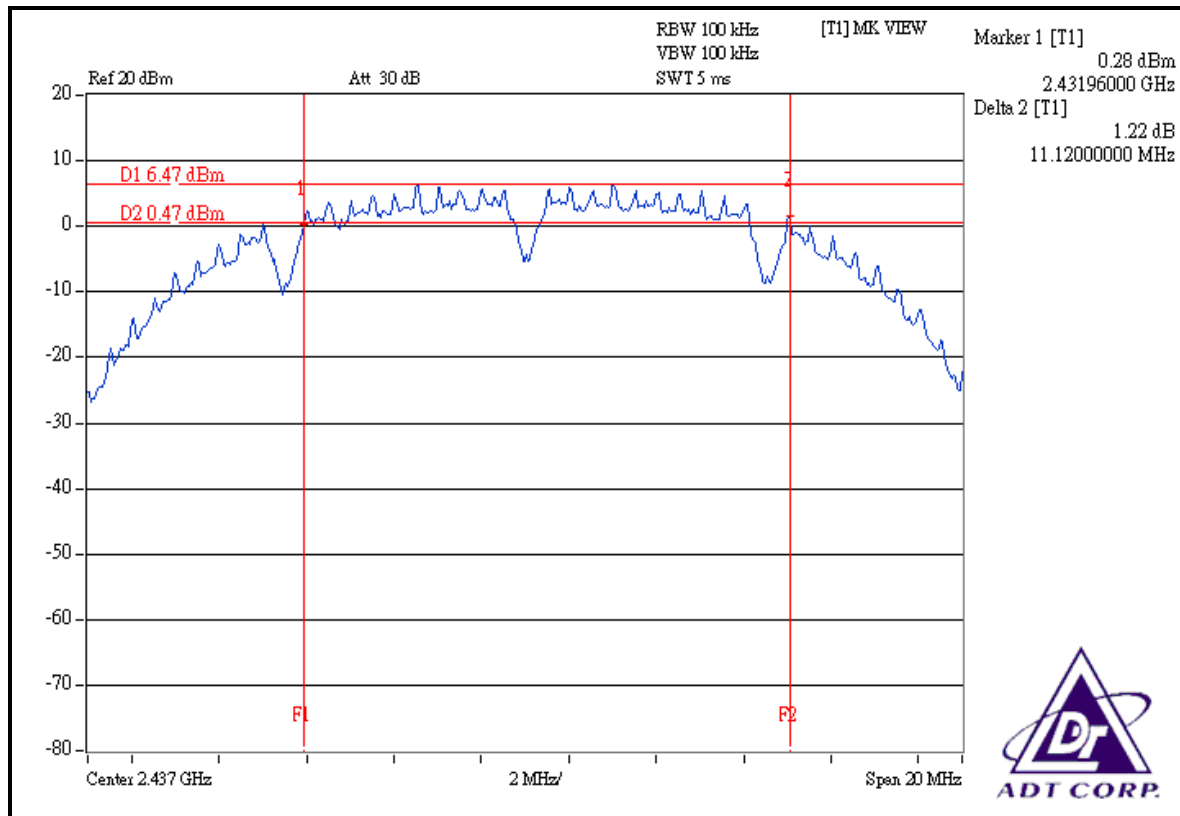



CH 11

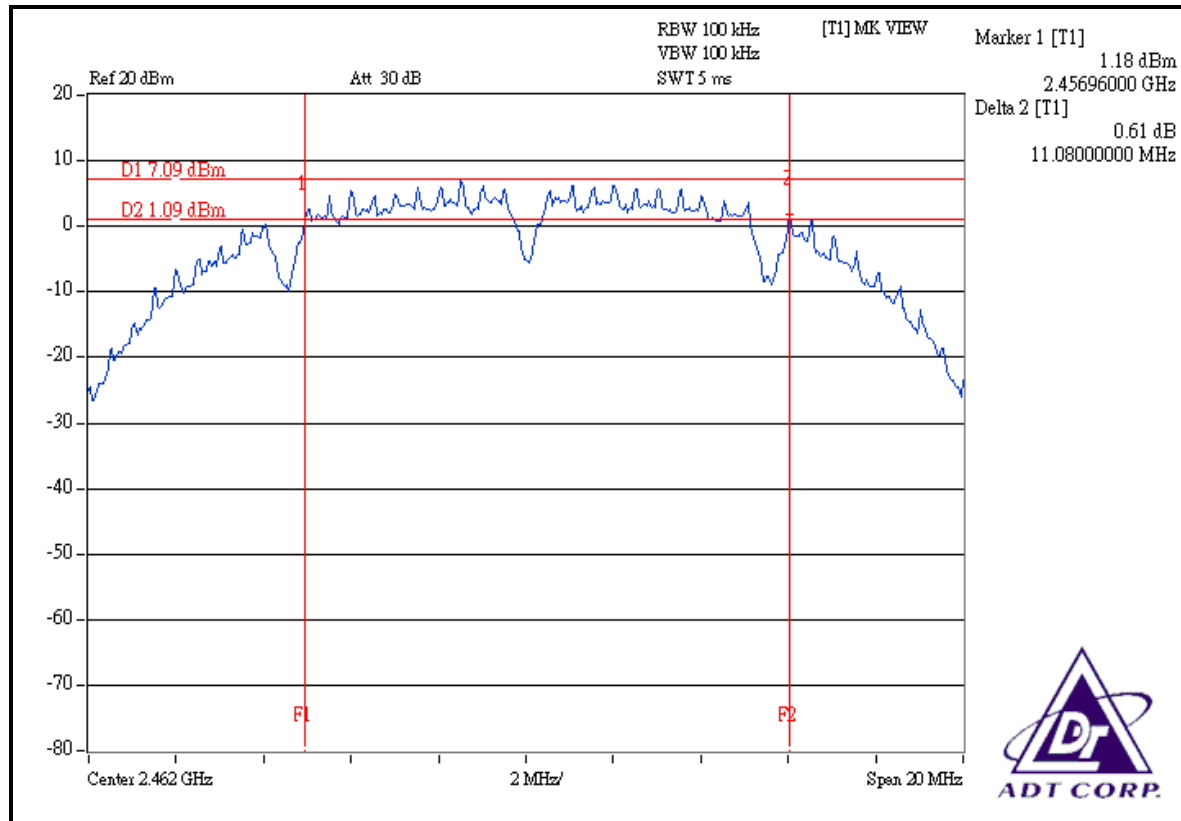



802.11g OFDM MODULATION_NORMAL MODE

MODULATION TYPE	BPSK	TRANSFER RATE	6Mbps
INPUT POWER (SYSTEM)	120Vac, 60 Hz	ENVIRONMENTAL CONDITIONS	23deg.C, 60%RH, 991hPa
TESTED BY	Match Tsui		

CHANNEL	CHANNEL FREQUENCY (MHz)	6dB BANDWIDTH (MHz)	MINIMUM LIMIT (MHz)	PASS/FAIL
1	2412	16.44	0.5	PASS
6	2437	16.40	0.5	PASS
11	2462	16.40	0.5	PASS



CH 1

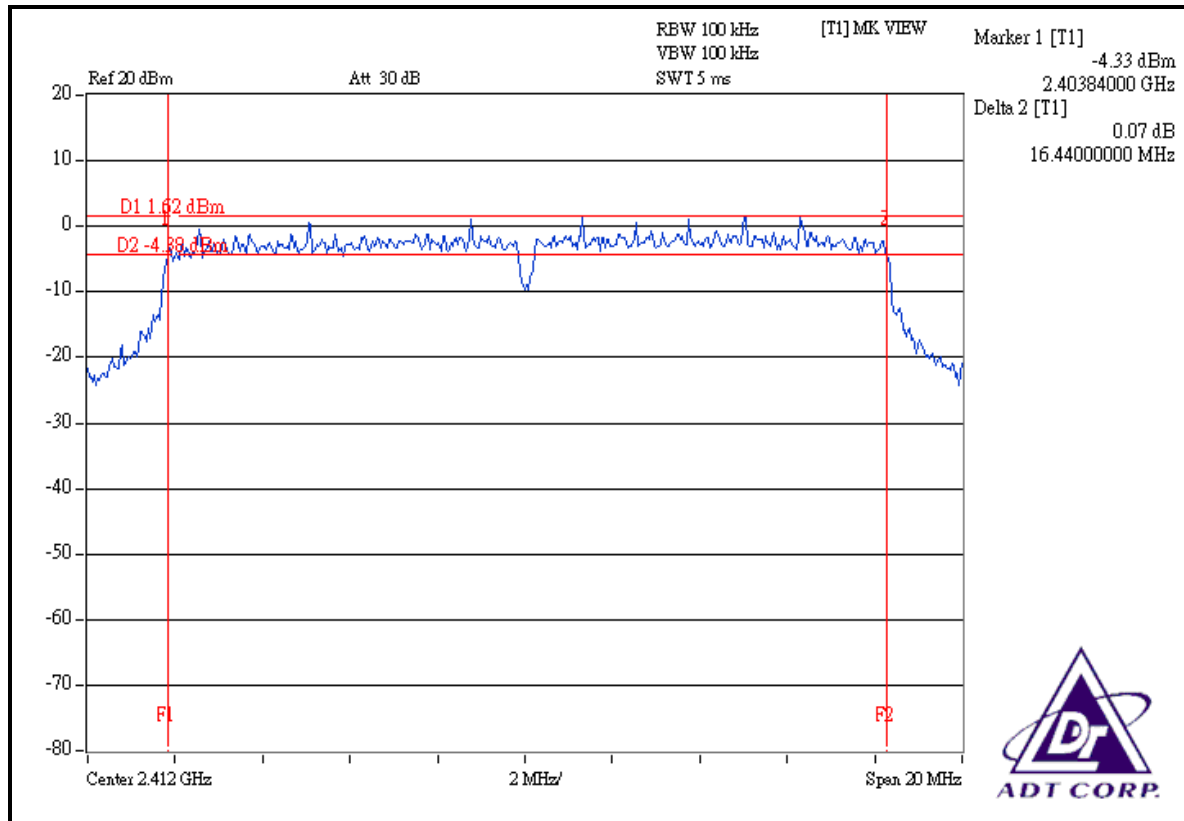

CH 6

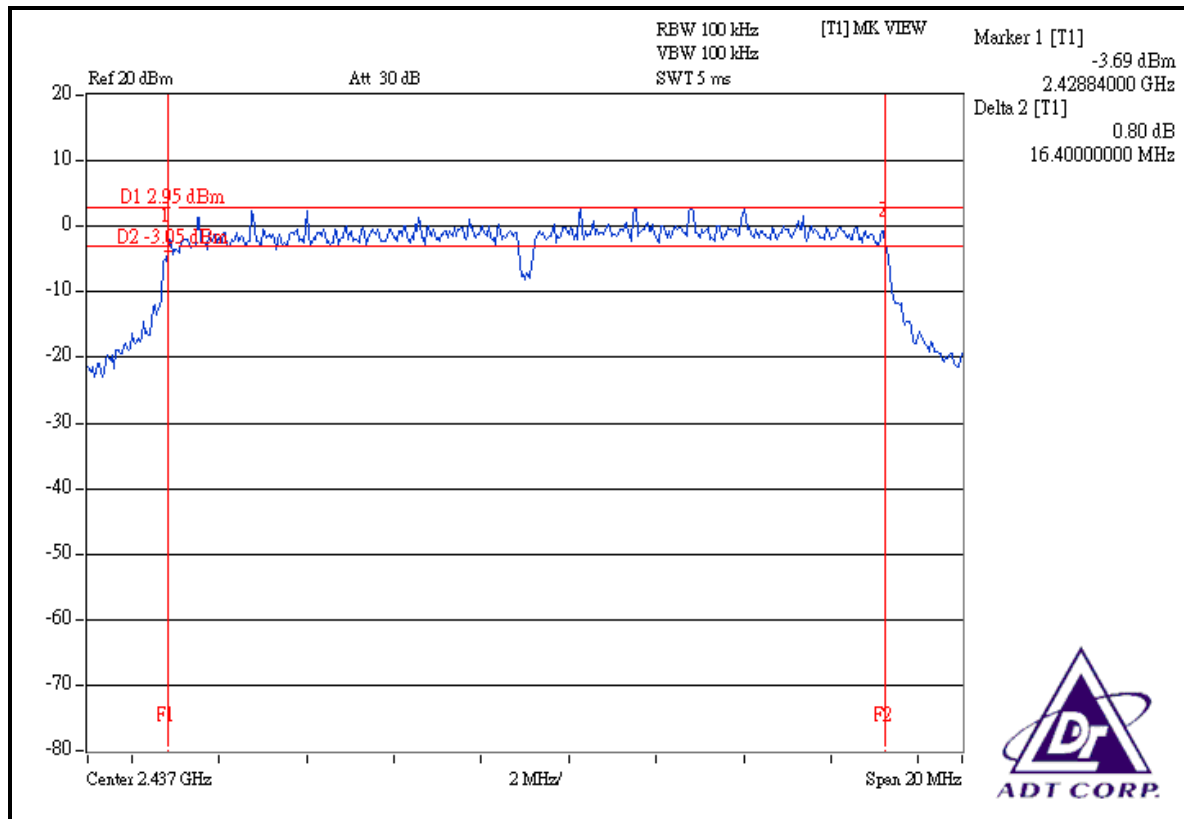

CH 11

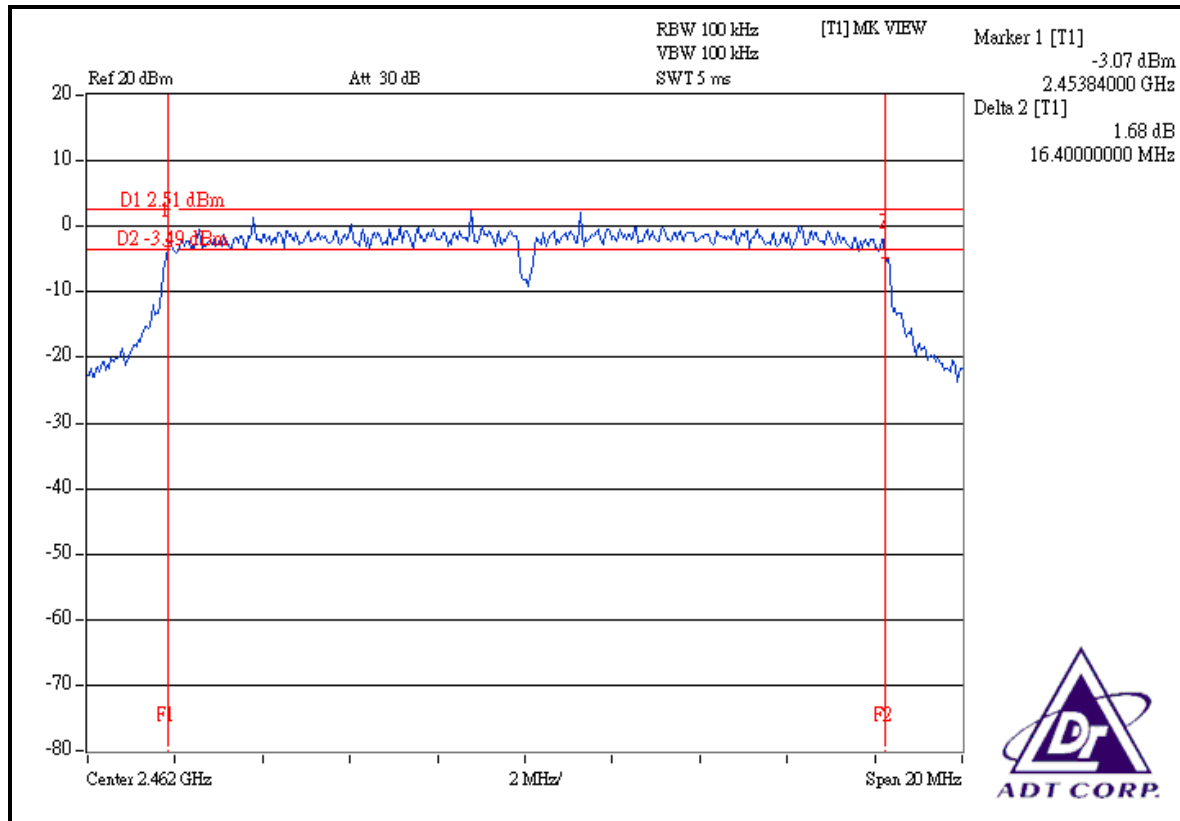



802.11g OFDM MODULATION_TURBO MODE

MODULATION TYPE	QPSK	TRANSFER RATE	12Mbps
INPUT POWER (SYSTEM)	120Vac, 60 Hz	ENVIRONMENTAL CONDITIONS	25deg.C, 68%RH, 1009hPa
TESTED BY	Morgan Chen		

CHANNEL	CHANNEL FREQUENCY (MHz)	6dB BANDWIDTH (MHz)	MINIMUM LIMIT (MHz)	PASS/FAIL
6	2437	31.36	0.5	PASS

CH 6

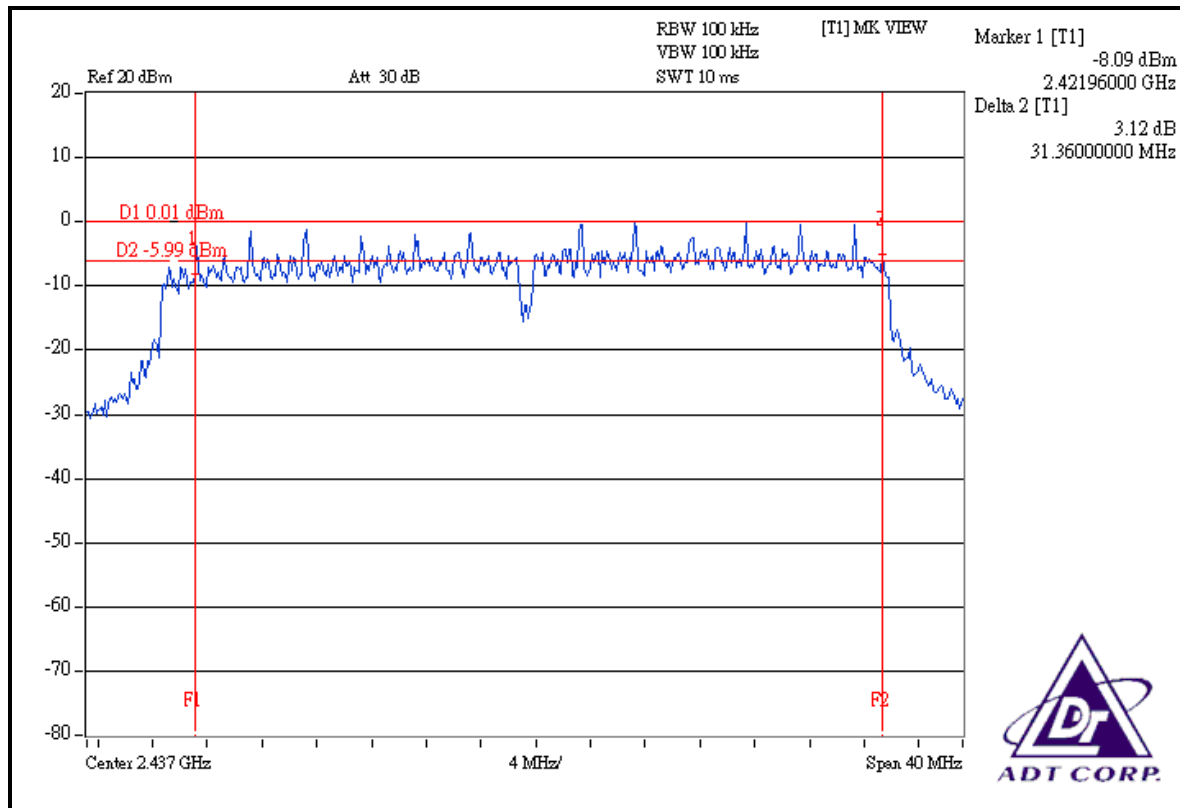



4.4 MAXIMUM PEAK OUTPUT POWER

4.4.1 LIMITS OF MAXIMUM PEAK OUTPUT POWER MEASUREMENT

The Maximum Peak Output Power Measurement is 30dBm.

4.4.2 TEST INSTRUMENTS

DESCRIPTION & MANUFACTURER	MODEL NO.	SERIAL NO.	CALIBRATED UNTIL
SPECTRUM ANALYZER	FSP40	100040	Jun. 07, 2007
R&S SIGNAL GENERATOR	SML03	102843	Aug. 31, 2007
TEKTRONIX OSCILLOSCOPE	TDS1012	C037299	Nov. 27, 2007
NARDA DETECTOR	4503A	FSCM99899	NA

NOTE: The calibration interval of the above test instruments is 12 months and the calibrations are traceable to NML/ROC and NIST/USA.

4.4.3 TEST PROCEDURES

1. A detector was used on the output port of the EUT. An oscilloscope was used to peak the response of the detector.
2. Replaced the EUT by the signal generator. The center frequency of the S.G was adjusted to the center frequency of the measured channel.
3. Adjusted the power to have the same peak reading on oscilloscope. Record the power level.

4.4.4 DEVIATION FROM TEST STANDARD

No deviation

4.4.5 TEST SETUP



4.4.6 EUT OPERATING CONDITIONS

Same as Item 4.3.6.



4.4.7 TEST RESULTS

802.11b DSSS MODULATION

MODULATION TYPE	DBPSK	TRANSFER RATE	1Mbps
INPUT POWER (SYSTEM)	120Vac, 60 Hz	ENVIRONMENTAL CONDITIONS	23deg.C, 60%RH, 991hPa
TESTED BY	Match Tsui		

CHANNEL	CHANNEL FREQUENCY (MHz)	PEAK POWER OUTPUT (mW)	PEAK POWER OUTPUT (dBm)	PEAK POWER LIMIT (dBm)	PASS/FAIL
1	2412	64.565	18.10	30	PASS
6	2437	80.353	19.05	30	PASS
11	2462	79.616	19.01	30	PASS

802.11g OFDM MODULATION_NORMAL MODE

MODULATION TYPE	BPSK	TRANSFER RATE	6Mbps
INPUT POWER (SYSTEM)	120Vac, 60 Hz	ENVIRONMENTAL CONDITIONS	23deg.C, 60%RH, 991hPa
TESTED BY	Match Tsui		

CHANNEL	CHANNEL FREQUENCY (MHz)	PEAK POWER OUTPUT (mW)	PEAK POWER OUTPUT (dBm)	PEAK POWER LIMIT (dBm)	PASS/FAIL
1	2412	72.111	18.58	30	PASS
6	2437	90.573	19.57	30	PASS
11	2462	72.277	18.59	30	PASS

802.11g OFDM MODULATION_TURBO MODE

MODULATION TYPE	QPSK	TRANSFER RATE	12Mbps
INPUT POWER (SYSTEM)	120Vac, 60 Hz	ENVIRONMENTAL CONDITIONS	25deg.C, 68%RH, 1009hPa
TESTED BY	Morgan Chen		

CHANNEL	CHANNEL FREQUENCY (MHz)	PEAK POWER OUTPUT (mW)	PEAK POWER OUTPUT (dBm)	PEAK POWER LIMIT (dBm)	PASS/FAIL
6	2437	72.111	18.58	30	PASS



4.5 POWER SPECTRAL DENSITY MEASUREMENT

4.5.1 LIMITS OF POWER SPECTRAL DENSITY MEASUREMENT

The Maximum of Power Spectral Density Measurement is 8dBm.

4.5.2 TEST INSTRUMENTS

DESCRIPTION & MANUFACTURER	MODEL NO.	SERIAL NO.	CALIBRATED UNTIL
SPECTRUM ANALYZER	FSP40	100040	Jun. 07, 2007

NOTE: The calibration interval of the above test instruments is 12 months and the calibrations are traceable to NML/ROC and NIST/USA.

4.5.3 TEST PROCEDURE

The transmitter output was connected to the spectrum analyzer through an attenuator, the bandwidth of the fundamental frequency was measured with the spectrum analyzer using 3kHz RBW and 30kHz VBW, set sweep time=span/3kHz. The power spectral density was measured and recorded. The sweep time is allowed to be longer than span/3kHz for a full response of the mixer in the spectrum analyzer.

4.5.4 DEVIATION FROM TEST STANDARD

No deviation

4.5.5 TEST SETUP



4.5.6 EUT OPERATING CONDITIONS

Same as 4.3.6.



4.5.7 TEST RESULTS

802.11b DSSS MODULATION

MODULATION TYPE	DBPSK	TRANSFER RATE	1Mbps
INPUT POWER (SYSTEM)	120Vac, 60 Hz	ENVIRONMENTAL CONDITIONS	23deg.C, 60%RH, 991hPa
TESTED BY	Match Tsui		

CHANNEL	CHANNEL FREQUENCY (MHz)	RF POWER LEVEL IN 3 kHz BW (dBm)	MAXIMUM LIMIT (dBm)	PASS/FAIL
1	2412	-8.17	8	PASS
6	2437	-6.97	8	PASS
11	2462	-7.22	8	PASS



CH 1

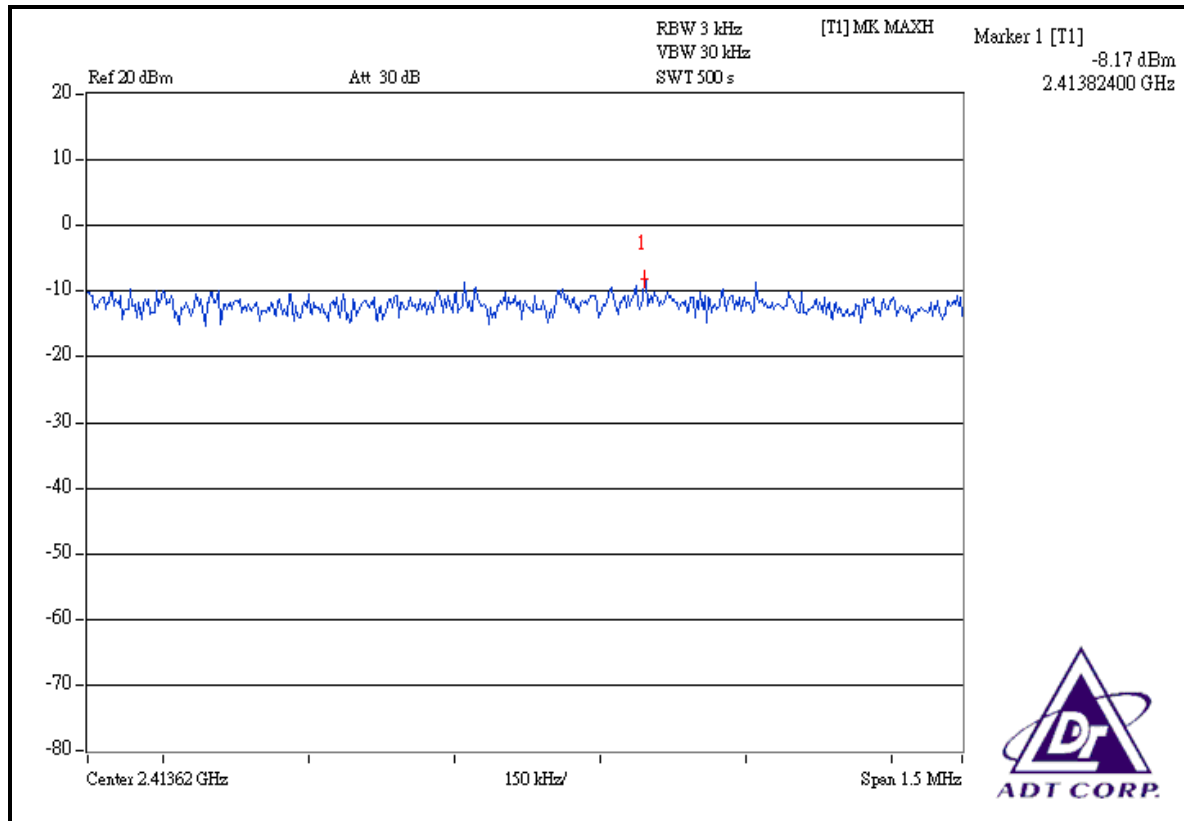

CH 6

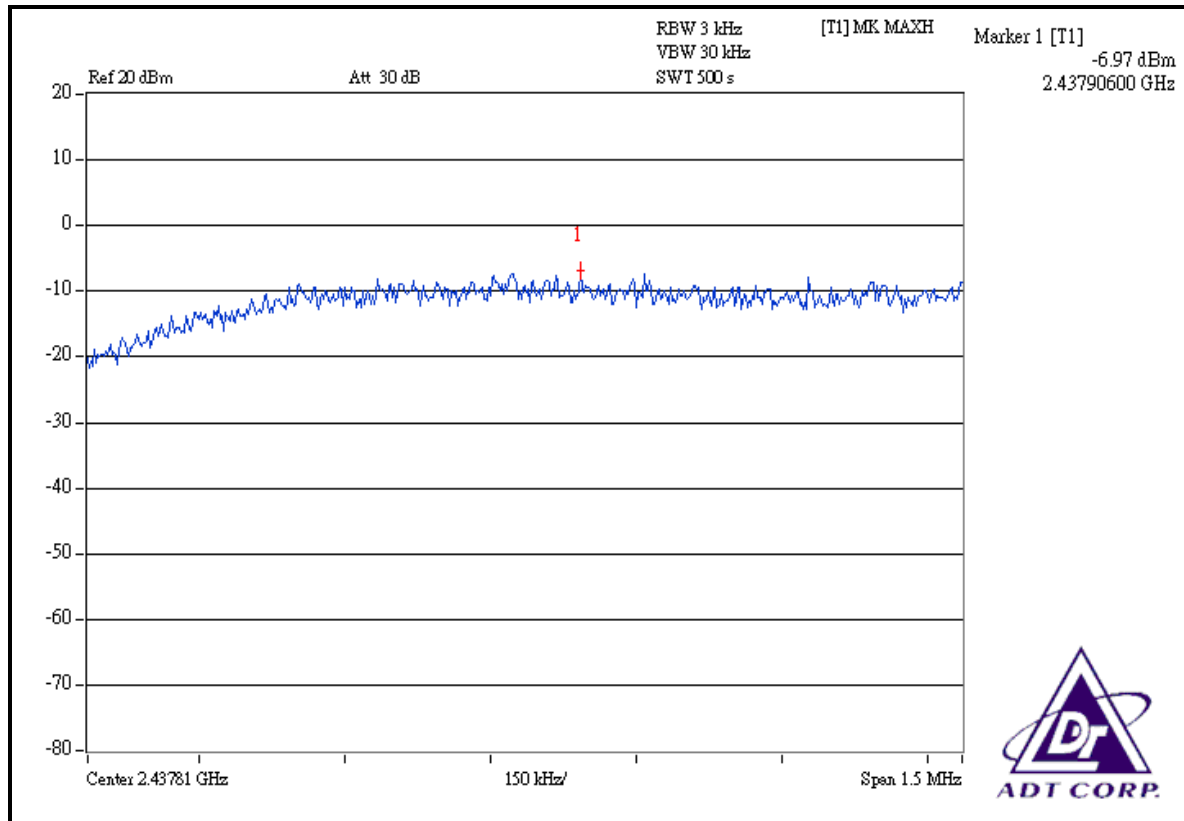



CH 11

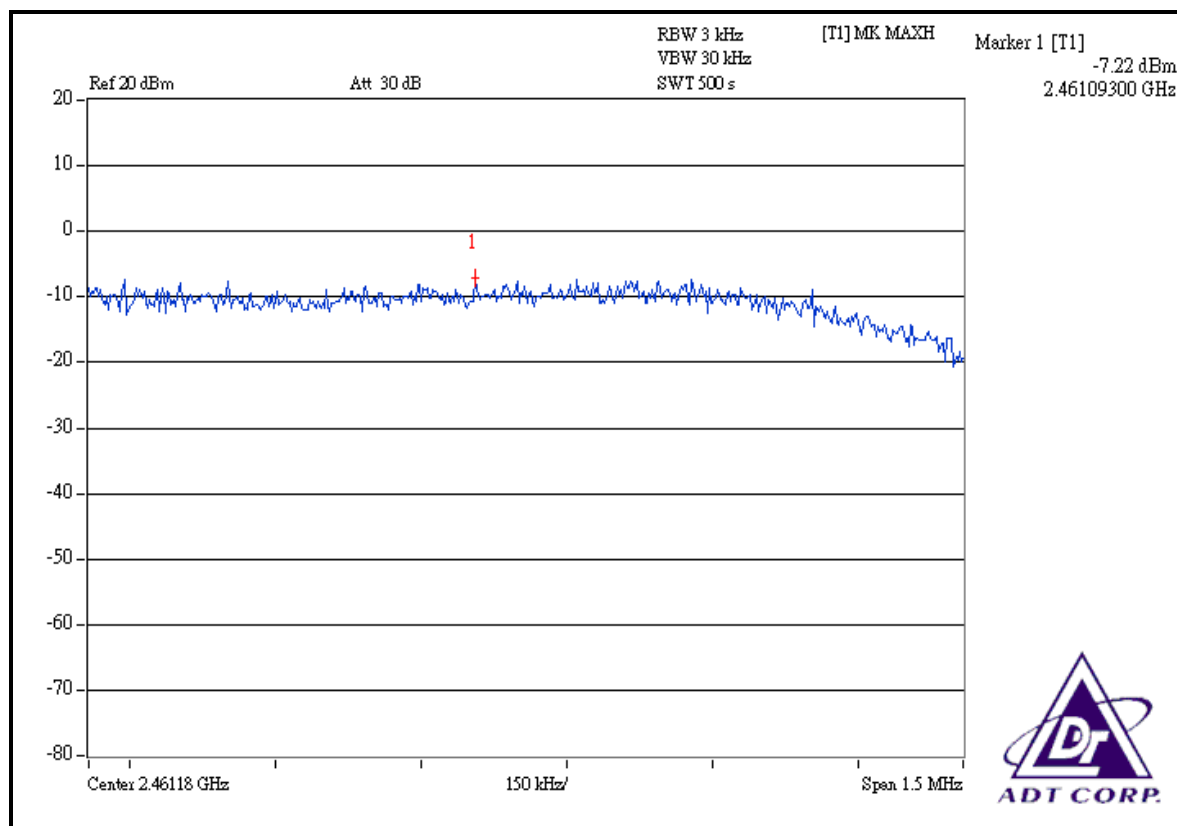



802.11g OFDM MODULATION_NORMAL MODE

MODULATION TYPE	BPSK	TRANSFER RATE	6Mbps
INPUT POWER (SYSTEM)	120Vac, 60 Hz	ENVIRONMENTAL CONDITIONS	23deg.C, 60%RH, 991hPa
TESTED BY	Match Tsui		

CHANNEL	CHANNEL FREQUENCY (MHz)	RF POWER LEVEL IN 3 kHz BW (dBm)	MAXIMUM LIMIT (dBm)	PASS/FAIL
1	2412	-11.89	8	PASS
6	2437	-11.06	8	PASS
11	2462	-11.62	8	PASS



CH 1

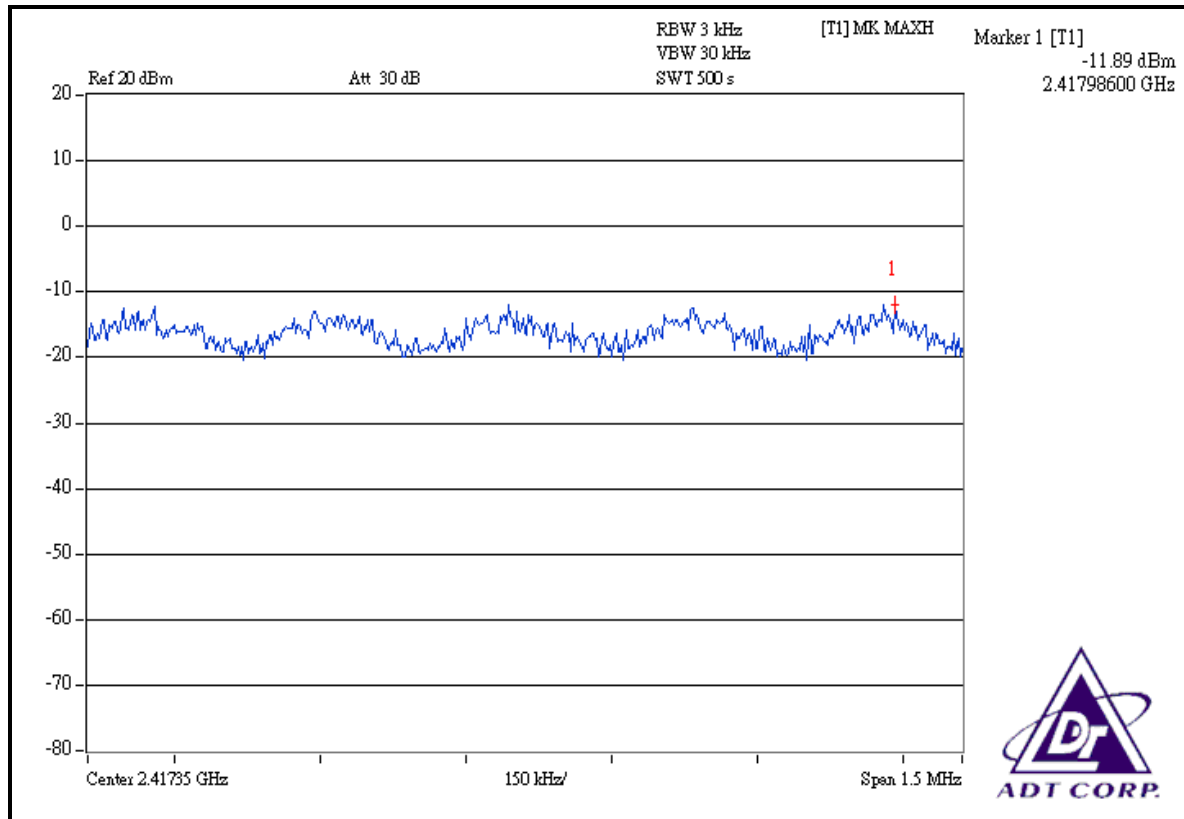

CH 6

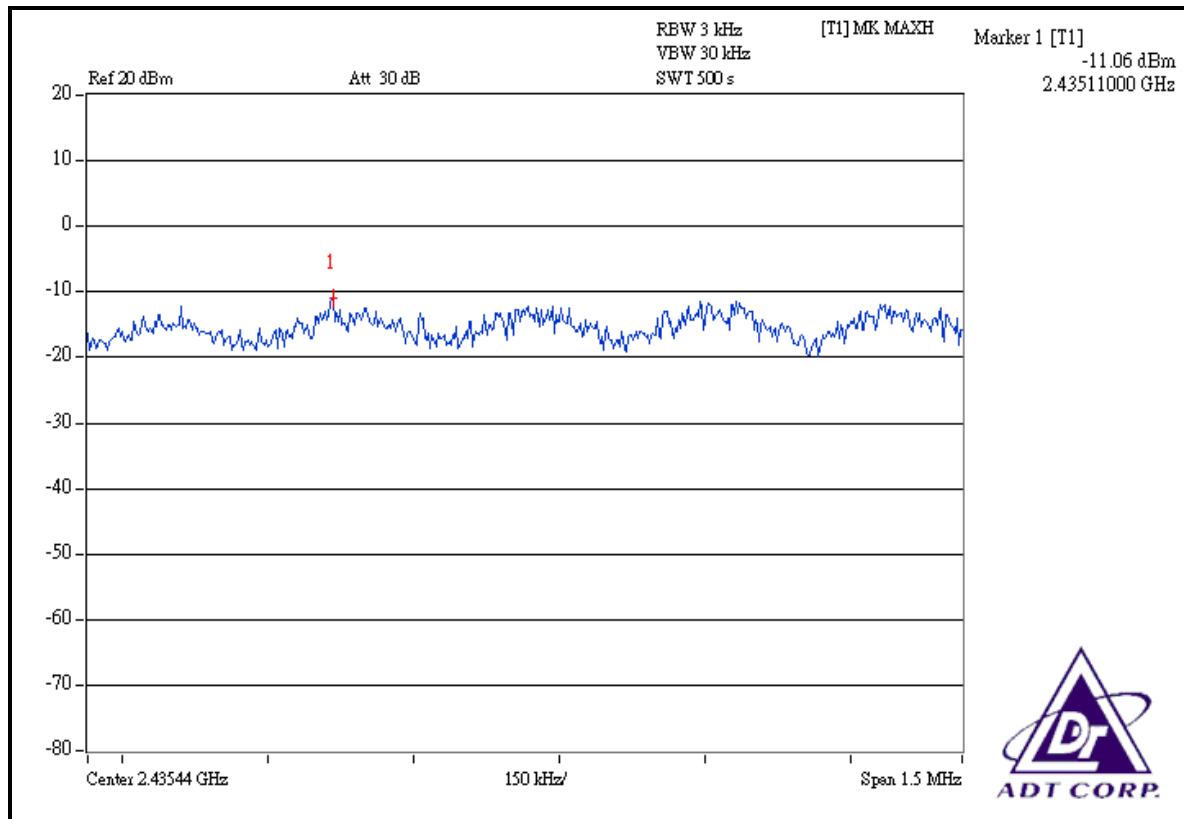



CH 11

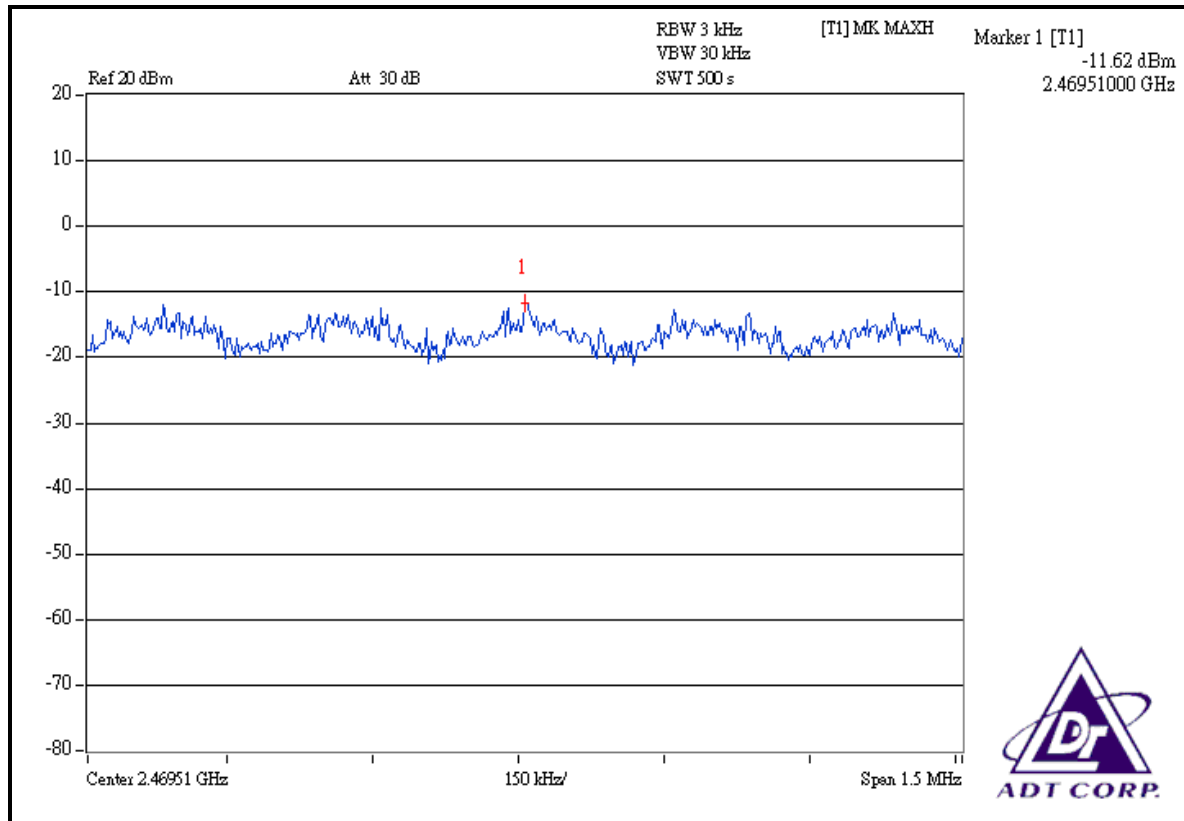



802.11g OFDM MODULATION_TURBO MODE

MODULATION TYPE	QPSK	TRANSFER RATE	12Mbps
INPUT POWER (SYSTEM)	120Vac, 60 Hz	ENVIRONMENTAL CONDITIONS	25deg.C, 68%RH, 1009hPa
TESTED BY	Morgan Chen		

CHANNEL	CHANNEL FREQUENCY (MHz)	RF POWER LEVEL IN 3 kHz BW (dBm)	MAXIMUM LIMIT (dBm)	PASS/FAIL
6	2437	-16.10	8	PASS

CH 6

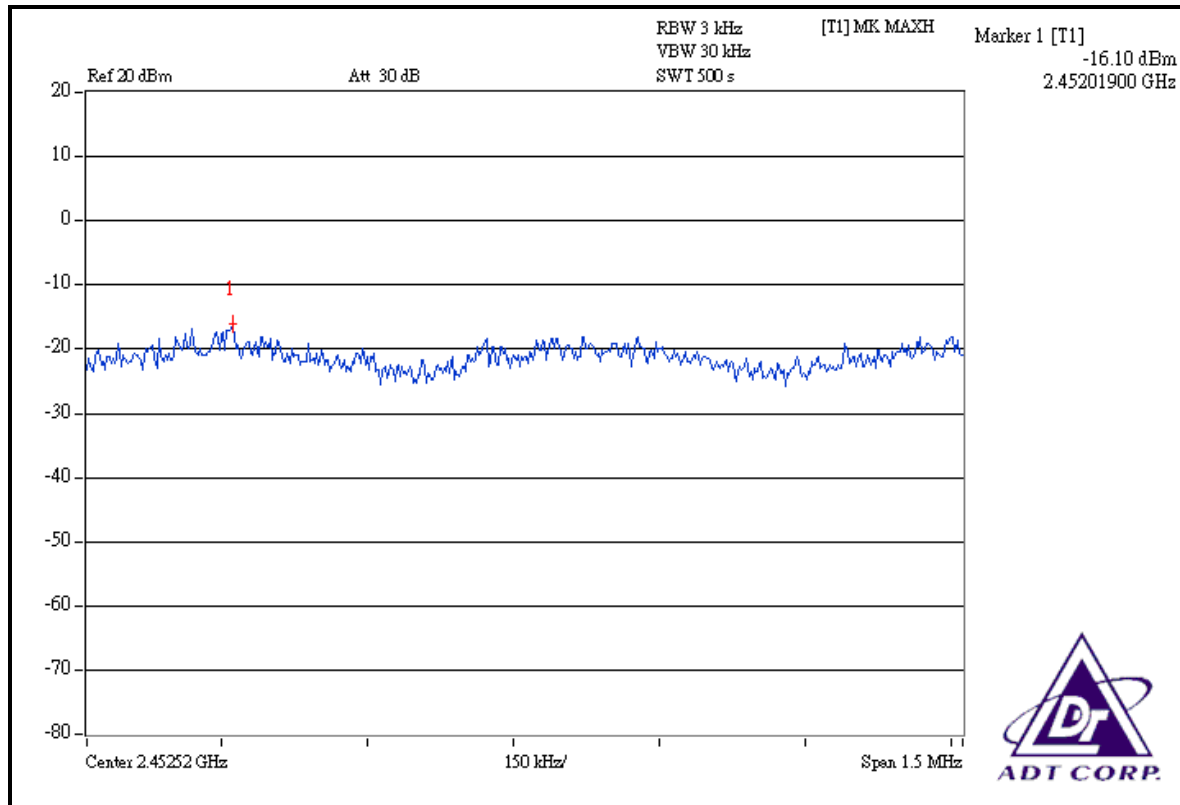



4.6 BAND EDGES MEASUREMENT

4.6.1 LIMITS OF BAND EDGES MEASUREMENT

Below -20dB of the highest emission level of operating band (in 100kHz Resolution Bandwidth).

4.6.2 TEST INSTRUMENTS

DESCRIPTION & MANUFACTURER	MODEL NO.	SERIAL NO.	CALIBRATED UNTIL
SPECTRUM ANALYZER	FSP40	100040	Jun. 07, 2007

NOTE: The calibration interval of the above test instruments is 12 months and the calibrations are traceable to NML/ROC and NIST/USA.

4.6.3 TEST PROCEDURE

The transmitter output was connected to the spectrum analyzer via a low loss cable. Set both RBW and VBW of spectrum analyzer to 100kHz with suitable frequency span including 100MHz bandwidth from band edge. The band edges was measured and recorded. The spectrum plots (Peak RBW=VBW=100kHz; Average RBW=1MHz, VBW=10Hz) are attached on the following pages.

4.6.4 DEVIATION FROM TEST STANDARD

No deviation

4.6.5 EUT OPERATING CONDITION

Same as Item 4.3.6.

4.6.6 TEST RESULTS

The spectrum plots are attached on the following 12 images. D1 line indicates the highest level, and D2 line indicates the 20dB offset below D1. It shows compliance with the requirement in part 15.247(d).

802.11b DSSS MODULATION

NOTE 1: The band edge emission plot on the next page shows 52.35dBc between carrier maximum power and local maximum emission in restrict band (2.38600GHz). The emission of carrier strength list in the test result of channel 1 at the item 4.2.7 is 110.80dBuV/m (Peak), so the maximum field strength in restrict band is $110.80 - 52.35 = 58.45$ dBuV/m which is under 74dBuV/m limit.

The band edge emission plot of on the next page shows 58.00dBc between carrier maximum power and local maximum emission in restrict band (2.38640GHz). The emission of carrier strength list in the test result of channel 1 at the item 4.2.7 is 106.34dBuV/m (Average), so the maximum field strength in restrict band is $106.34 - 58.00 = 48.34$ dBuV/m which is under 54dBuV/m limit.

NOTE 2: The band edge emission plot on the next second page shows 52.76dBc between carrier maximum power and local maximum emission in restrict band (2.48780GHz). The emission of carrier strength list in the test result of channel 11 at the item 4.2.7 is 110.65dBuV/m (Peak), so the maximum field strength in restrict band is $110.65 - 52.76 = 57.89$ dBuV/m which is under 74dBuV/m limit.

The band edge emission plot on the next third page shows 56.52dBc between carrier maximum power and local maximum emission in restrict band (2.48760GHz). The emission of carrier strength list in the test result of channel 11 at the item 4.2.7 is 105.05dBuV/m (Average), so the maximum field strength in restrict band is $105.05 - 56.52 = 48.53$ dBuV/m which is under 54dBuV/m limit.

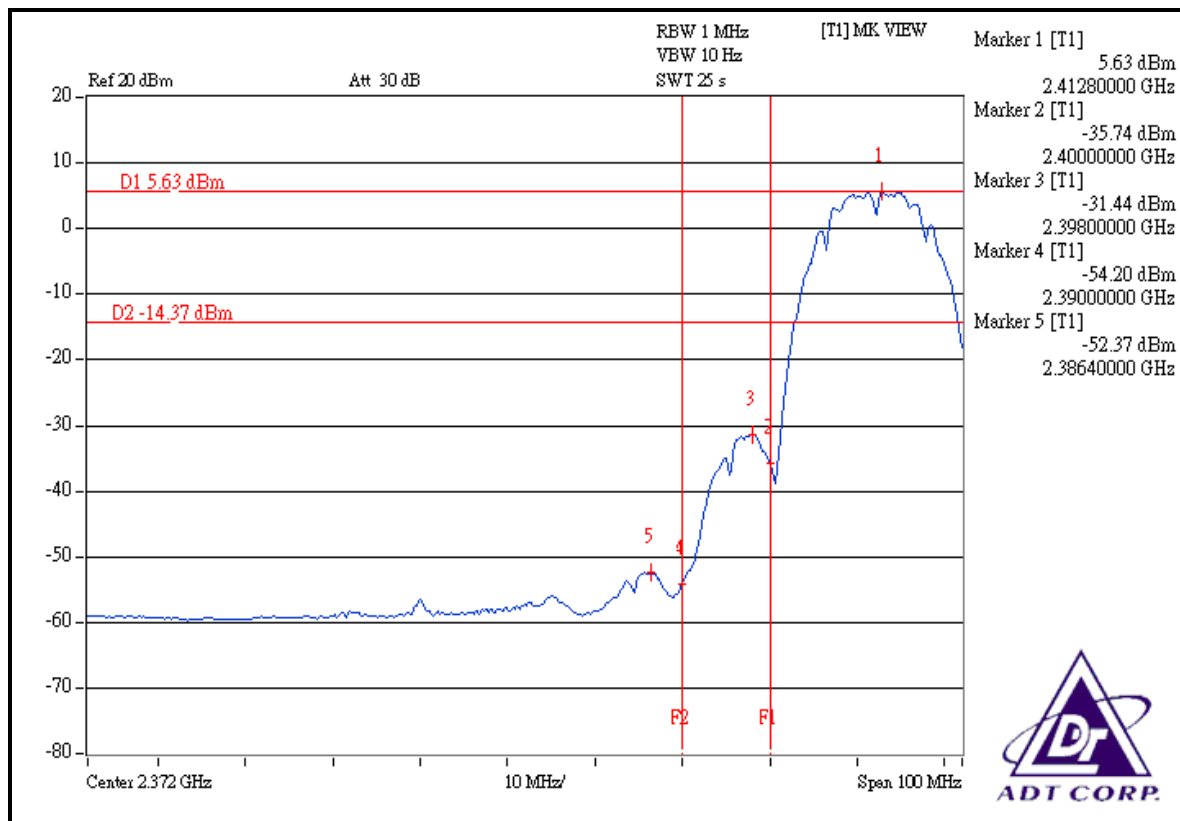
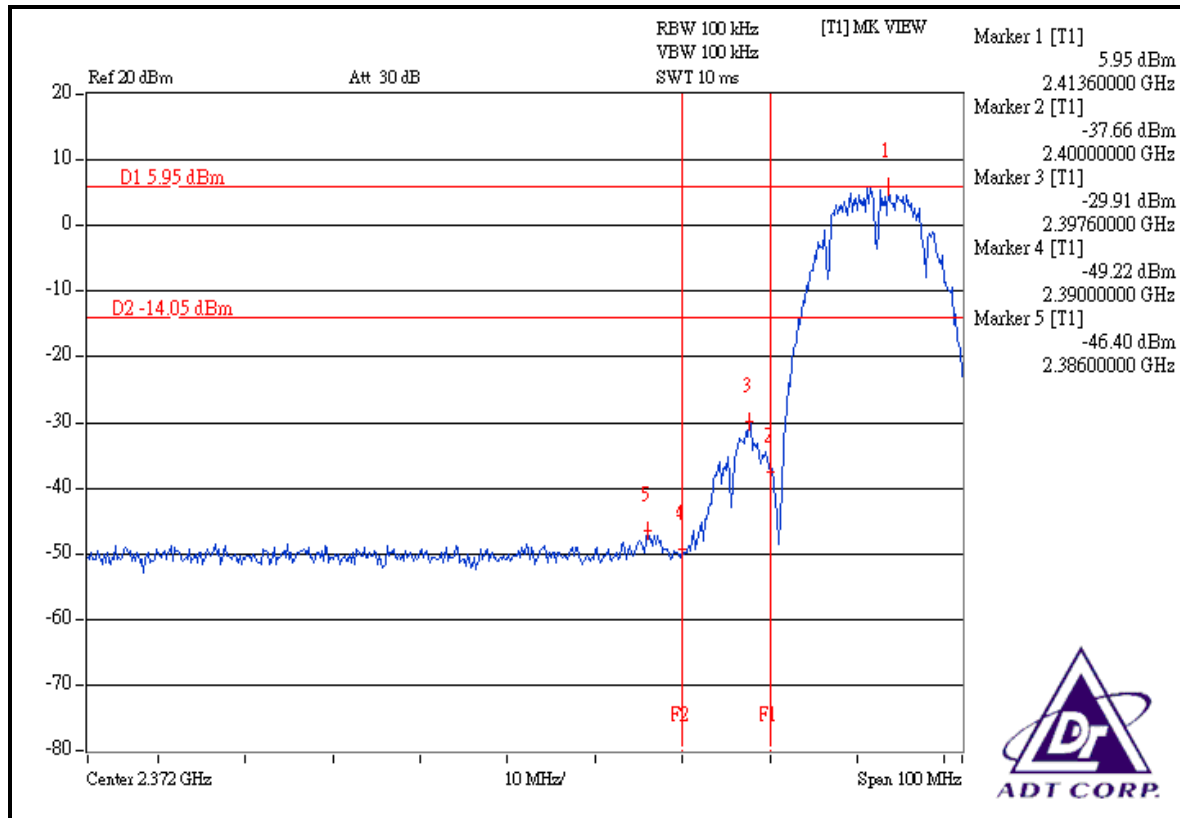

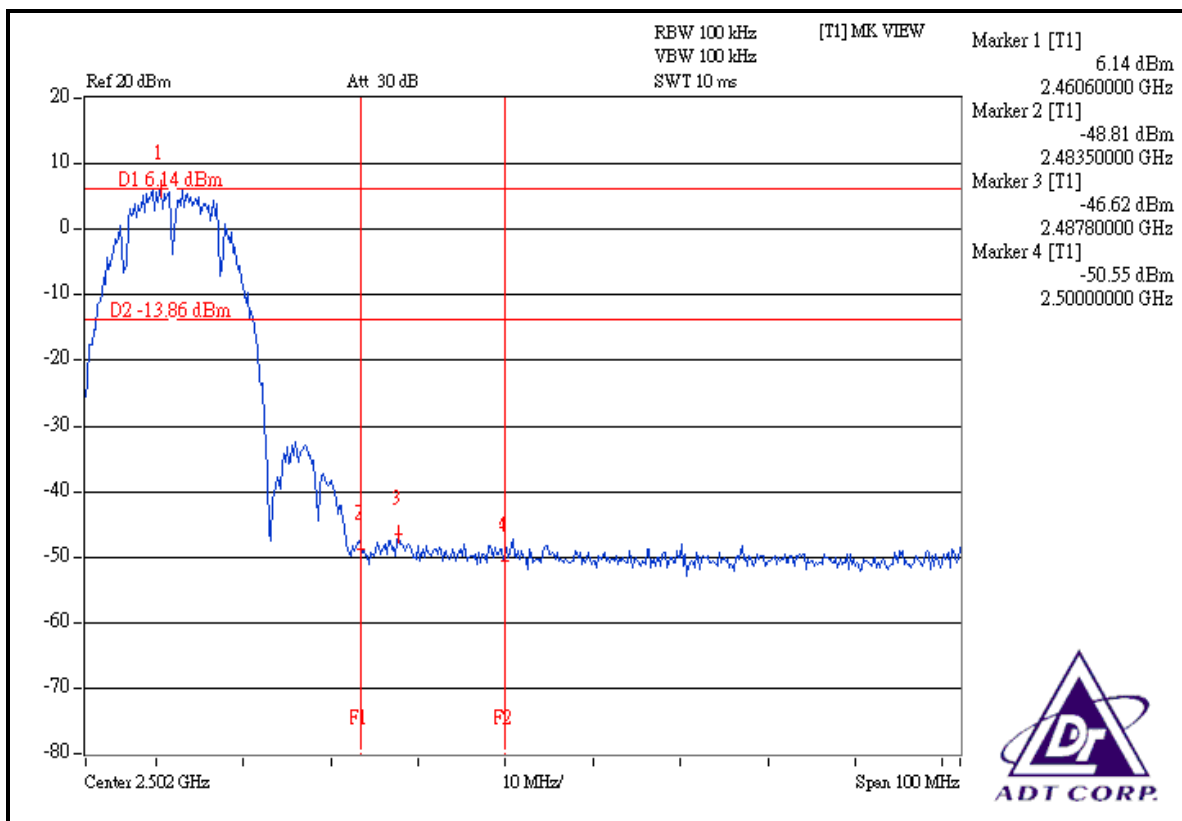
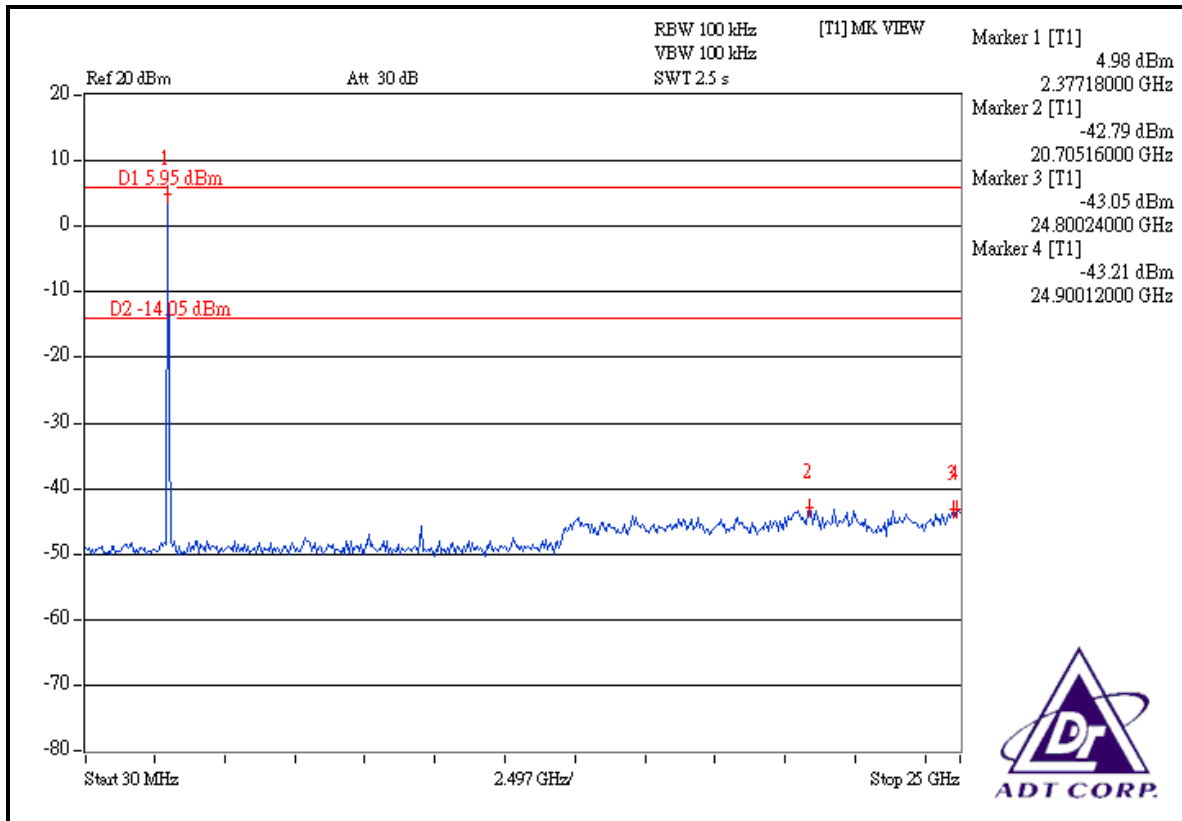

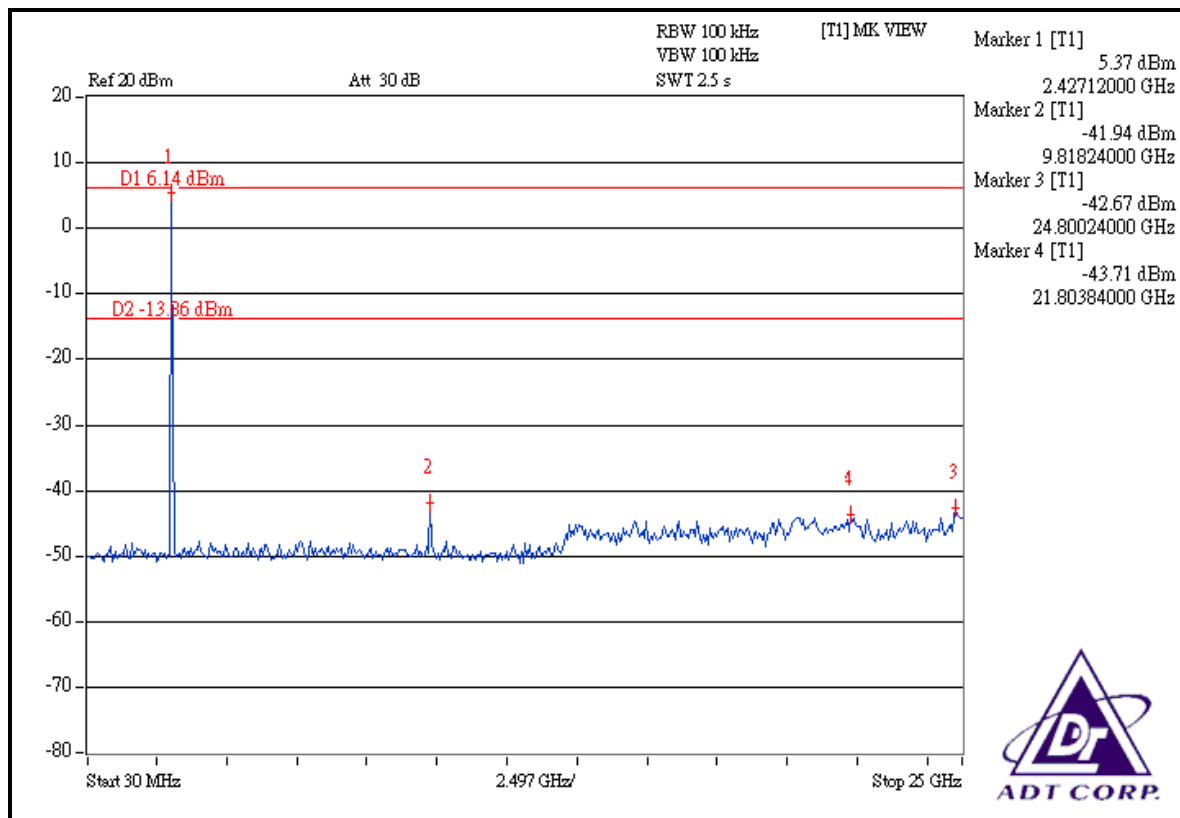
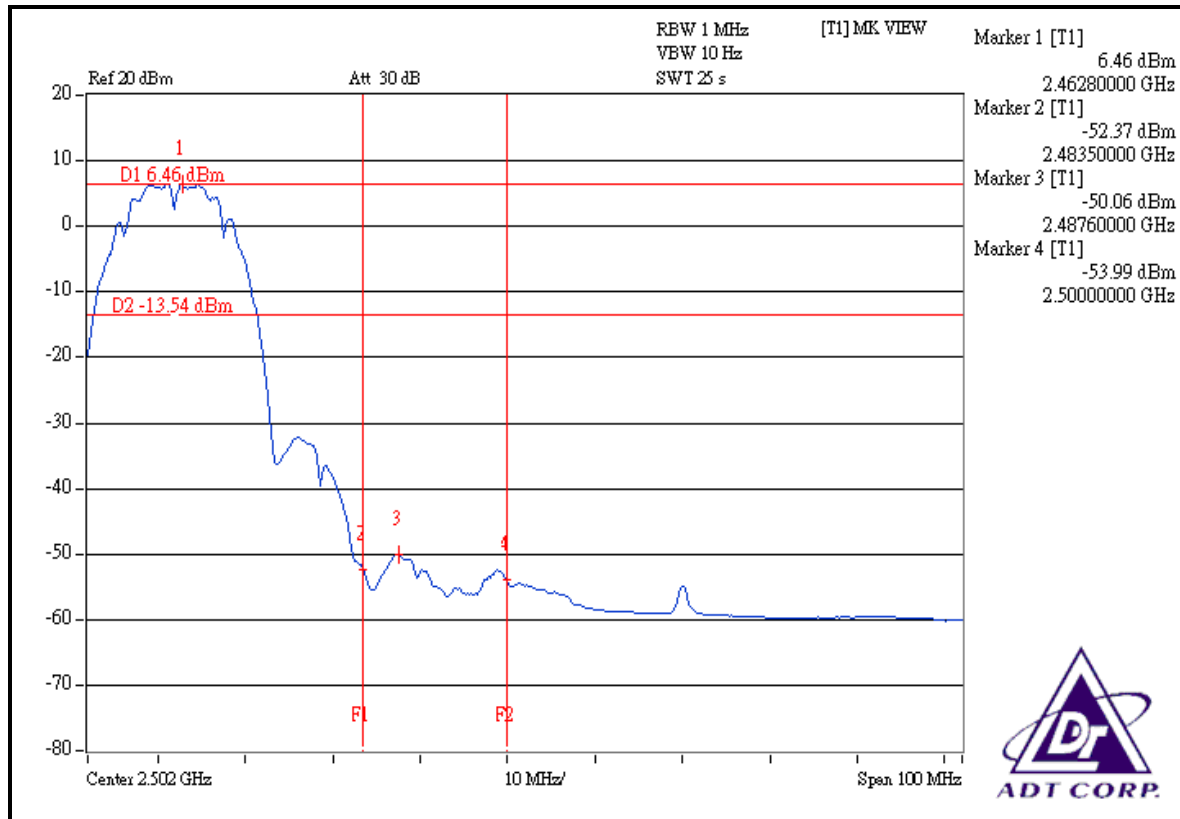



802.11g OFDM MODULATION_NORMAL MODE

NOTE 1: The band edge emission plot on the next page shows 44.47dBc between carrier maximum power and local maximum emission in restrict band (2.38960GHz). The emission of carrier strength list in the test result of channel 1 at the item 4.2.7 is 109.32dBuV/m (Peak), so the maximum field strength in restrict band is $109.32 - 44.47 = 64.85$ dBuV/m which is under 74dBuV/m limit.

The band edge emission plot of on the next page shows 49.16dBc between carrier maximum power and local maximum emission in restrict band (2.39000GHz). The emission of carrier strength list in the test result of channel 1 at the item 4.2.7 is 99.09dBuV/m (Average), so the maximum field strength in restrict band is $99.09 - 49.16 = 49.93$ dBuV/m which is under 54dBuV/m limit.

NOTE 2: The band edge emission plot on the next second page shows 44.10dBc between carrier maximum power and local maximum emission in restrict band (2.48440GHz). The emission of carrier strength list in the test result of channel 11 at the item 4.2.7 is 108.88dBuV/m (Peak), so the maximum field strength in restrict band is $108.88 - 44.10 = 64.78$ dBuV/m which is under 74dBuV/m limit.

The band edge emission plot on the next third page shows 46.75dBc between carrier maximum power and local maximum emission in restrict band (2.48350GHz). The emission of carrier strength list in the test result of channel 11 at the item 4.2.7 is 98.32dBuV/m (Average), so the maximum field strength in restrict band is $98.32 - 46.75 = 51.57$ dBuV/m which is under 54dBuV/m limit.

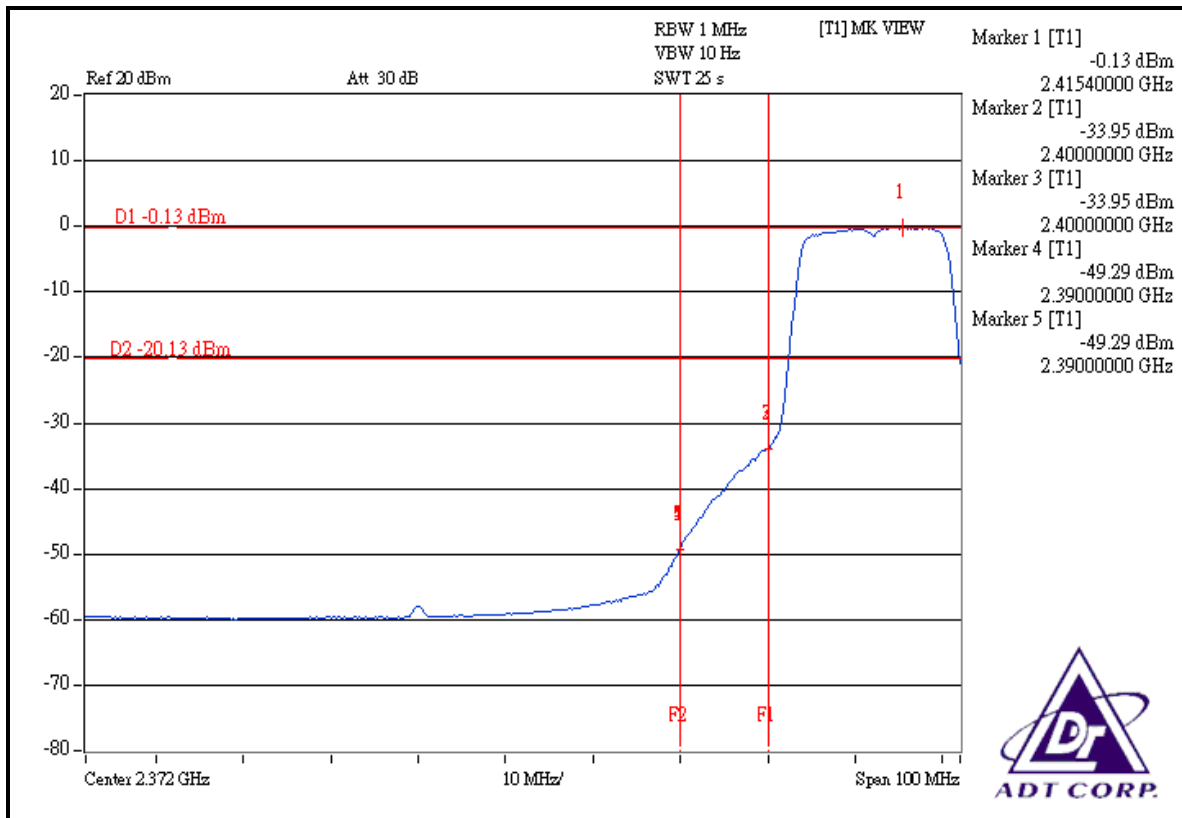
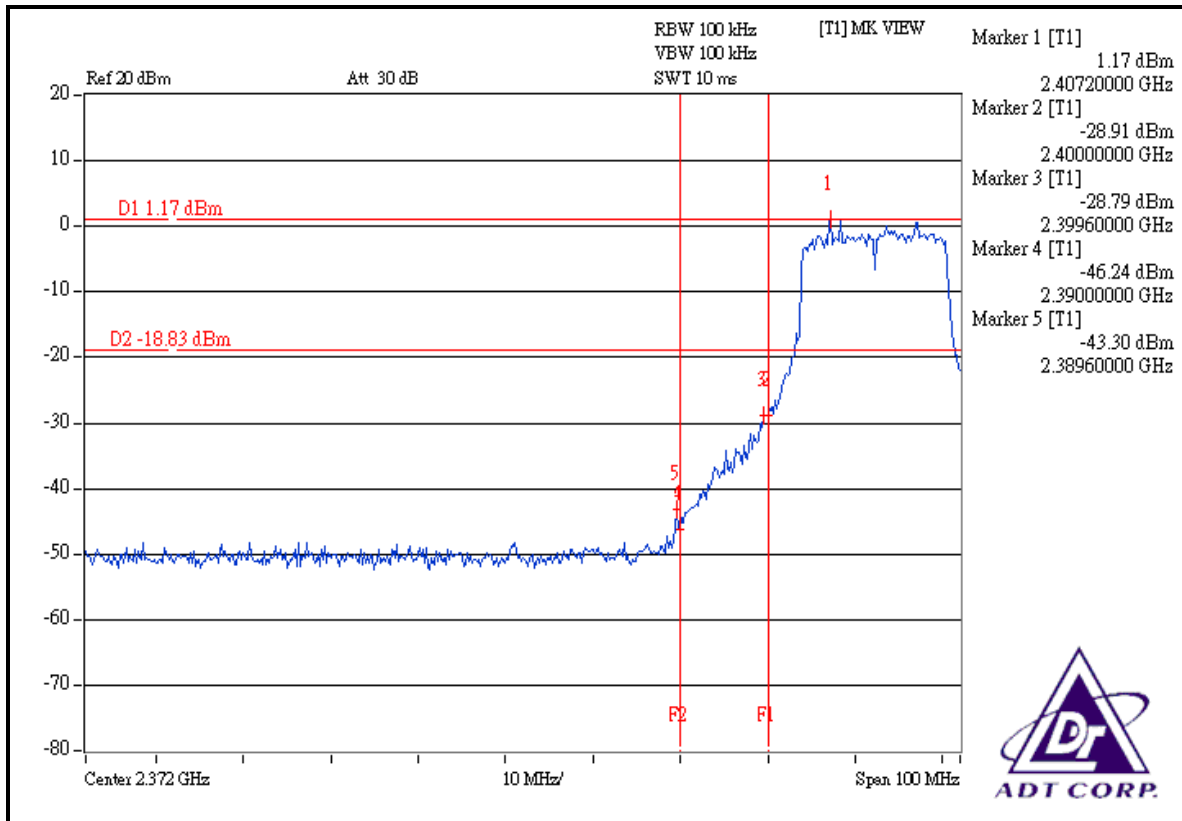

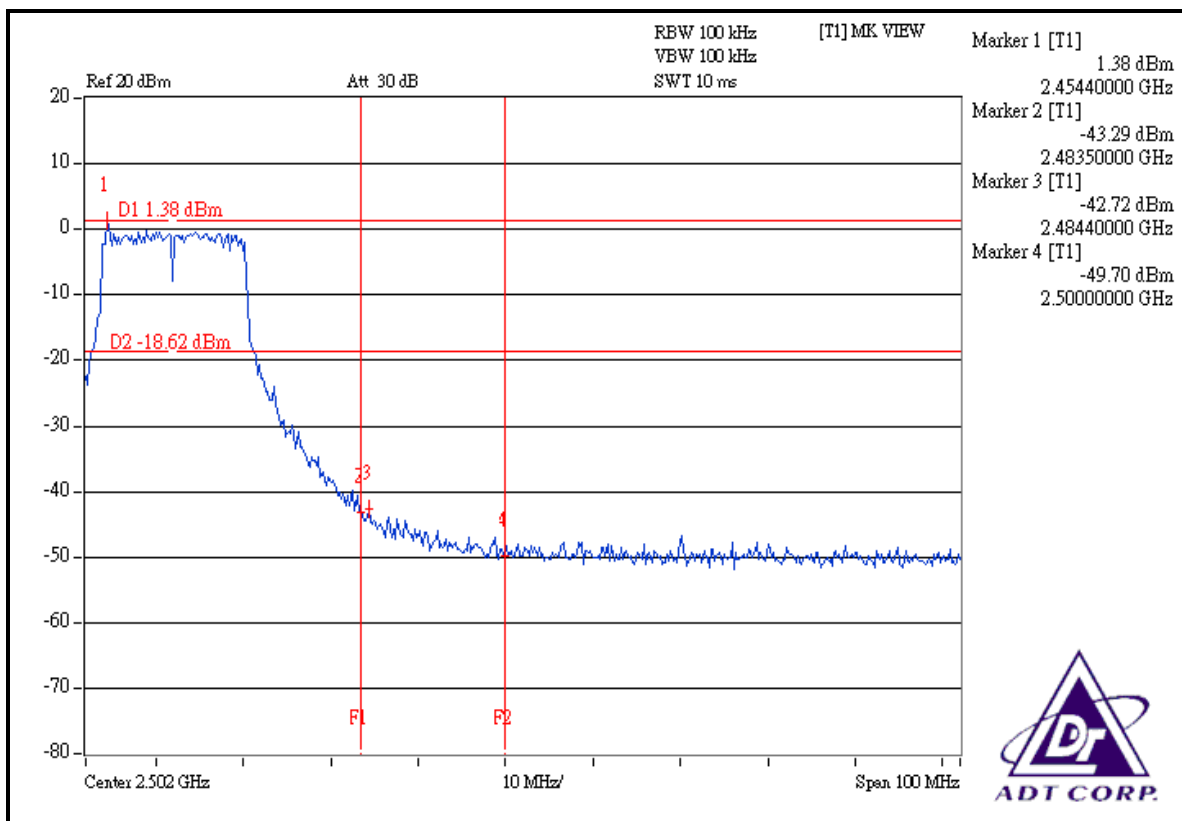
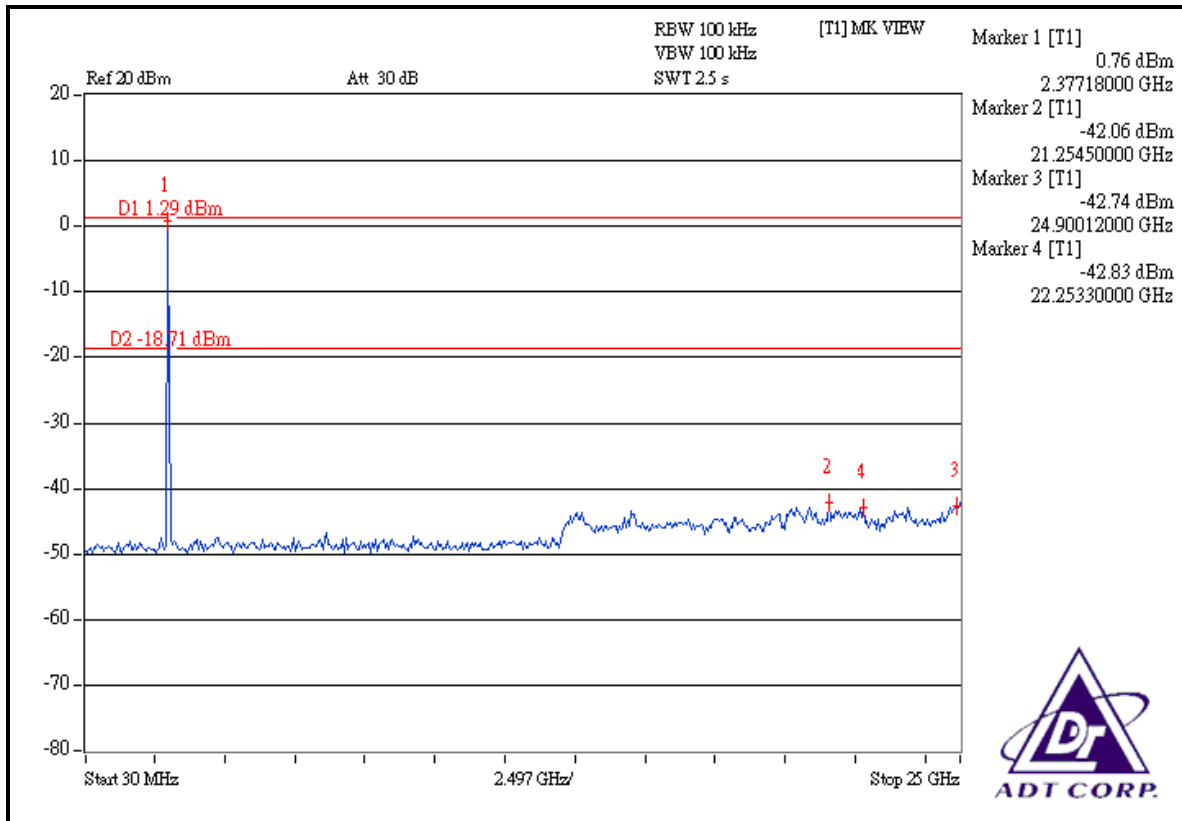

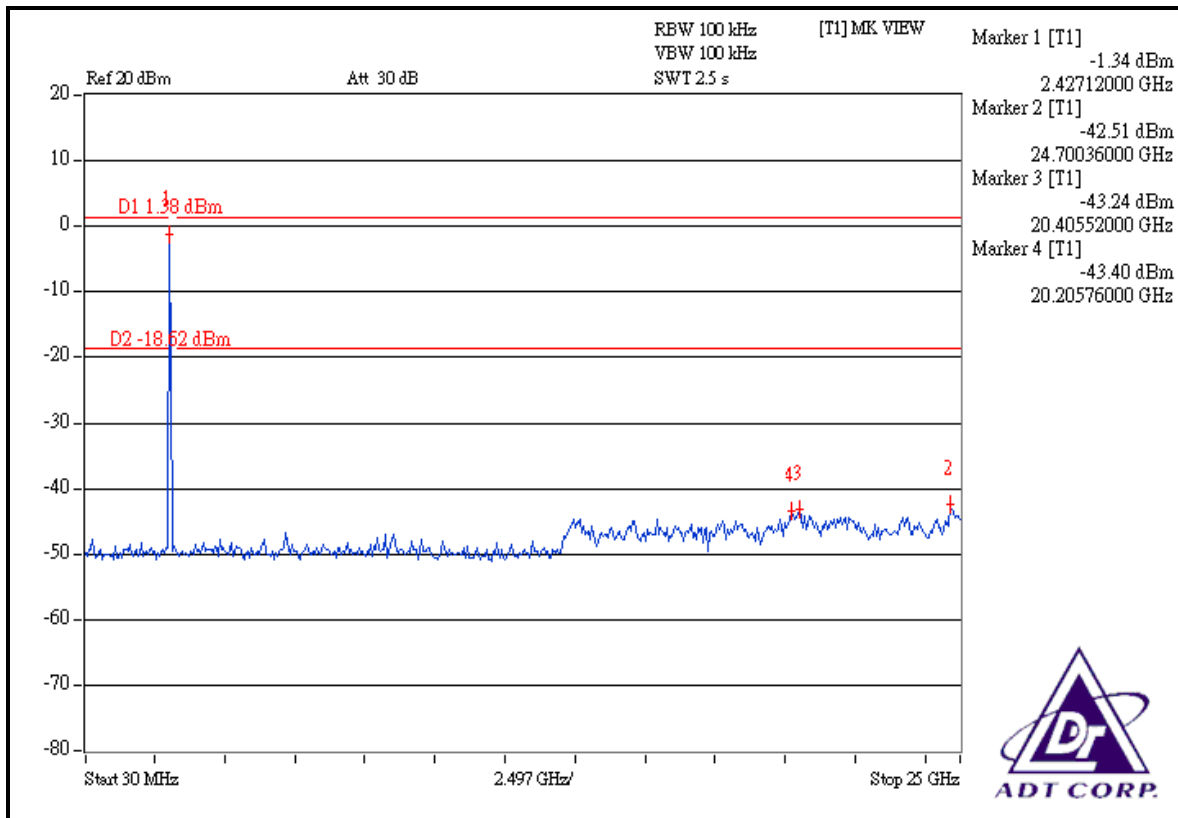
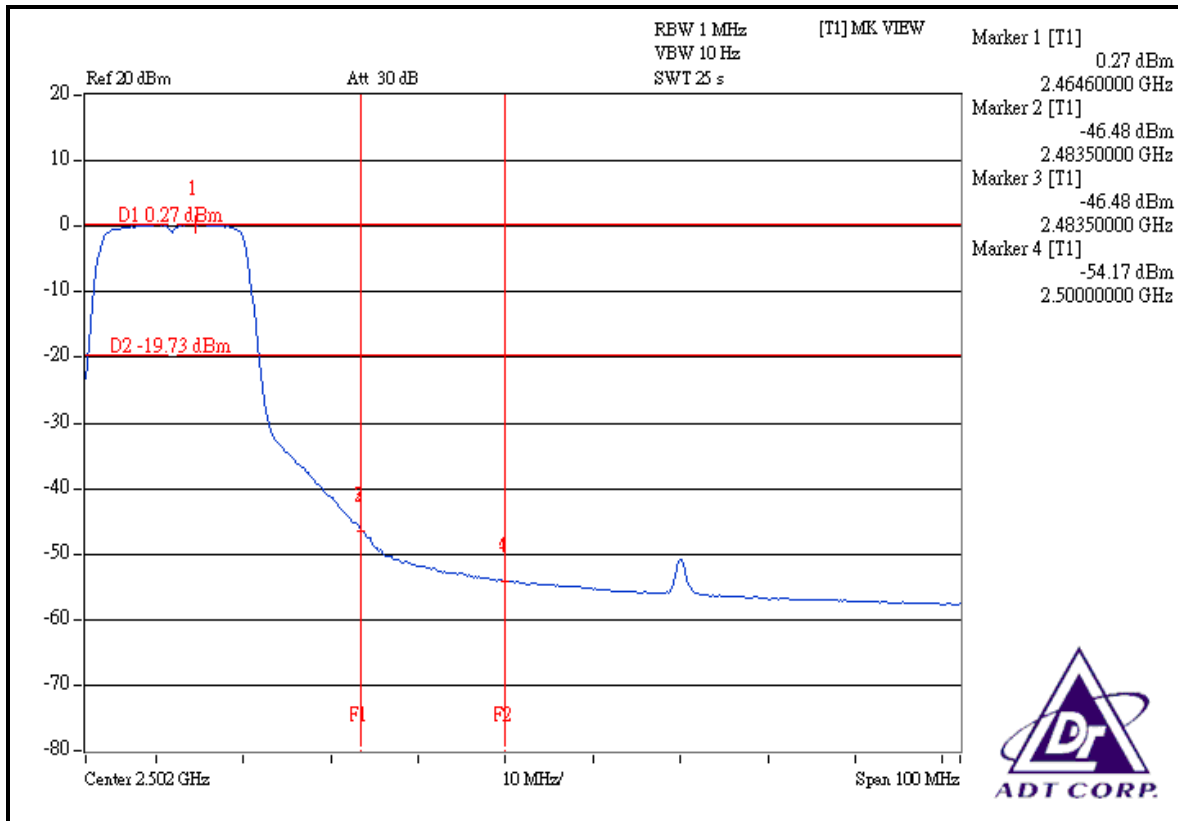



802.11g OFDM MODULATION_TURBO MODE

NOTE 1: The band edge emission plot on the next page shows 47.91dBc between carrier maximum power and local maximum emission in restrict band (2.34700GHz). The emission of carrier strength list in the test result of channel 6 at the item 4.2.7 is 108.12dBuV/m (Peak), so the maximum field strength in restrict band is $108.12 - 47.91 = 60.21$ dBuV/m which is under 74dBuV/m limit.

The band edge emission plot on the next page shows 49.24dBc between carrier maximum power and local maximum emission in restrict band (2.31980GHz). The emission of carrier strength list in the test result of channel 6 at the item 4.2.7 is 97.67dBuV/m (Average), so the maximum field strength in restrict band is $97.67 - 49.24 = 48.43$ dBuV/m which is under 54dBuV/m limit.

NOTE 2: The band edge emission plot on the next second page shows 46.65dBc between carrier maximum power and local maximum emission in restrict band (2.49160GHz). The emission of carrier strength list in the test result of channel 6 at the item 4.2.7 is 108.12dBuV/m (Peak), so the maximum field strength in restrict band is $108.12 - 46.65 = 61.47$ dBuV/m which is under 74dBuV/m limit.

The band edge emission plot on the next third page shows 48.88dBc between carrier maximum power and local maximum emission in restrict band (2.48350GHz). The emission of carrier strength list in the test result of channel 6 at the item 4.2.7 is 97.67dBuV/m (Average), so the maximum field strength in restrict band is $97.67 - 48.88 = 48.79$ dBuV/m which is under 54dBuV/m limit.

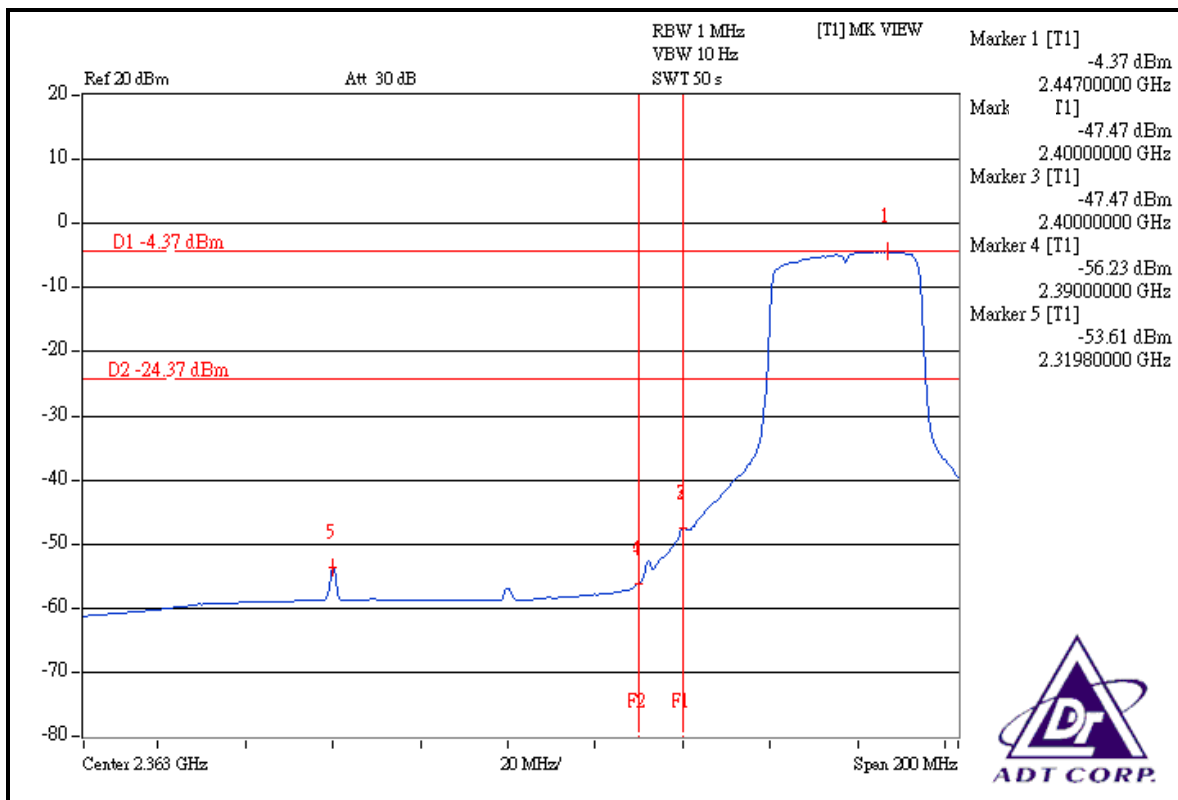
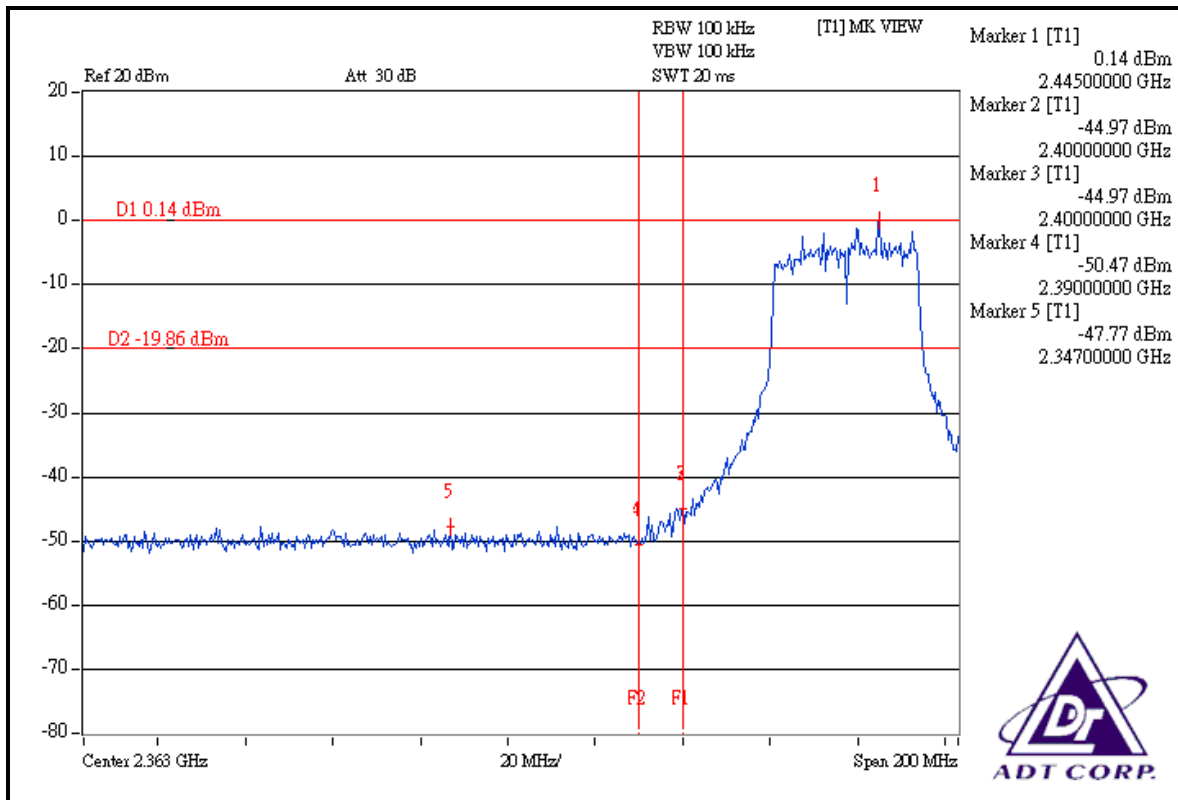

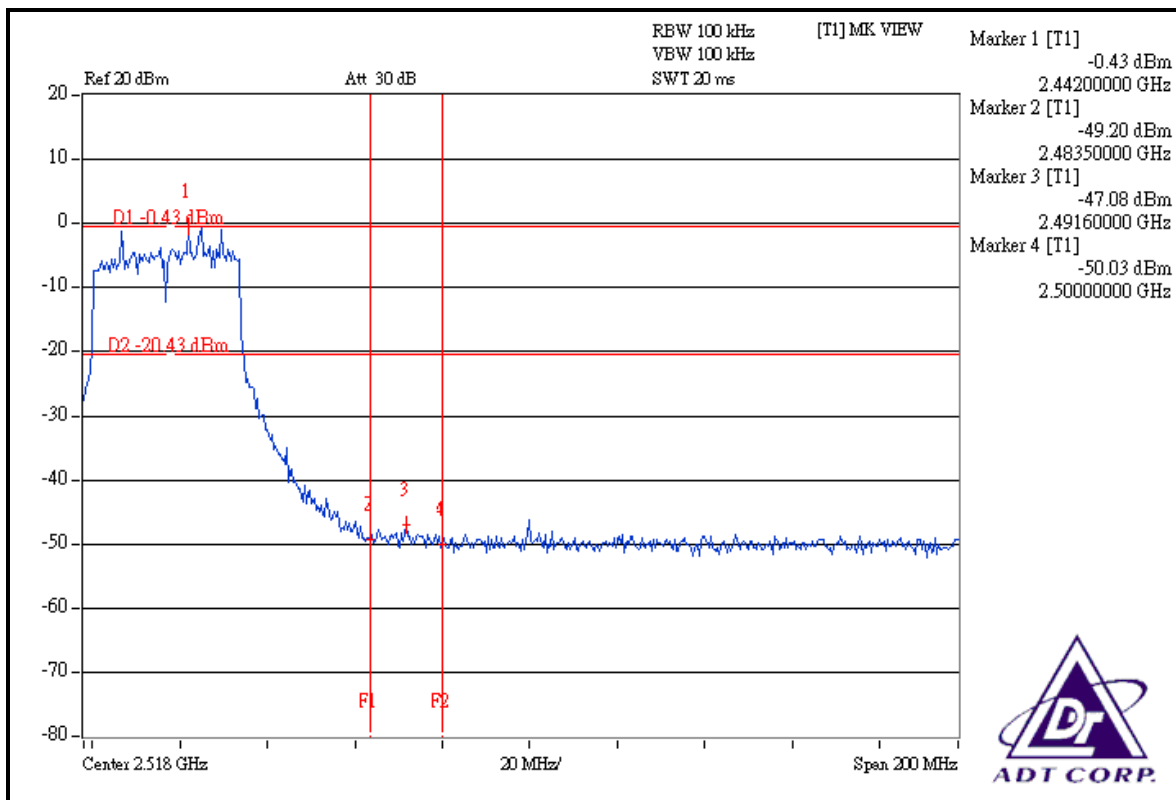
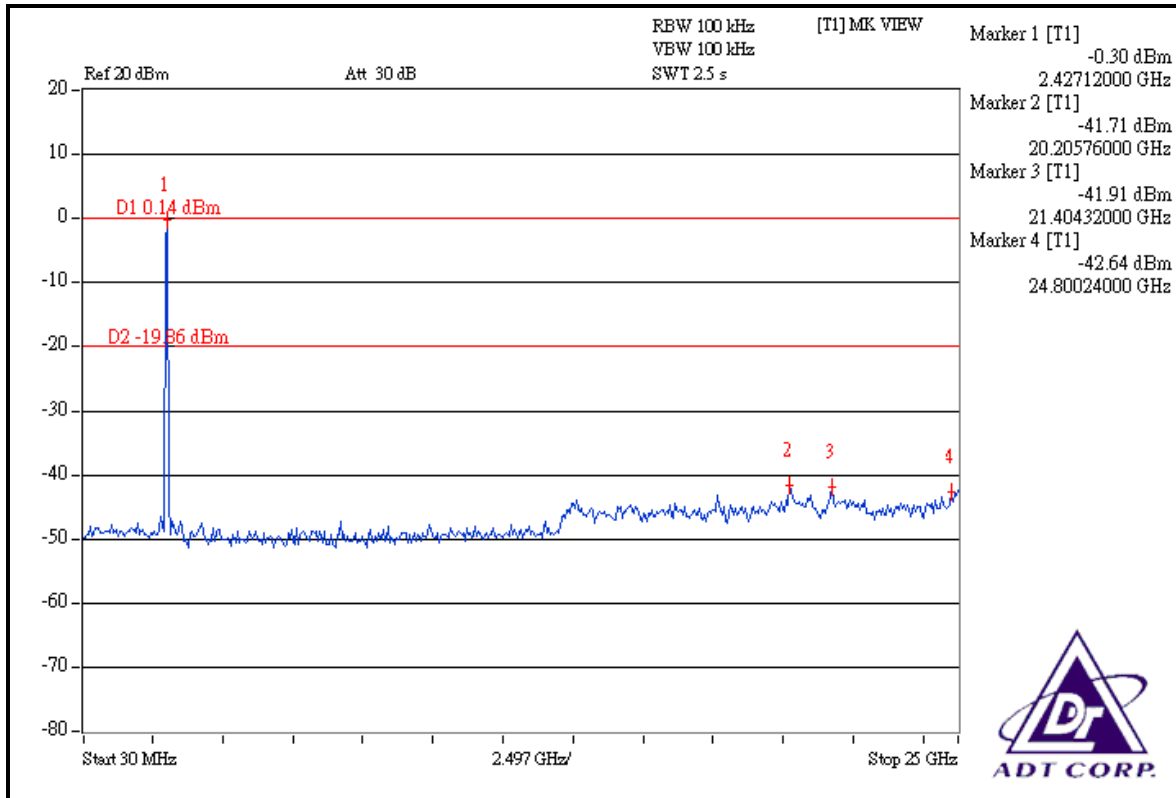

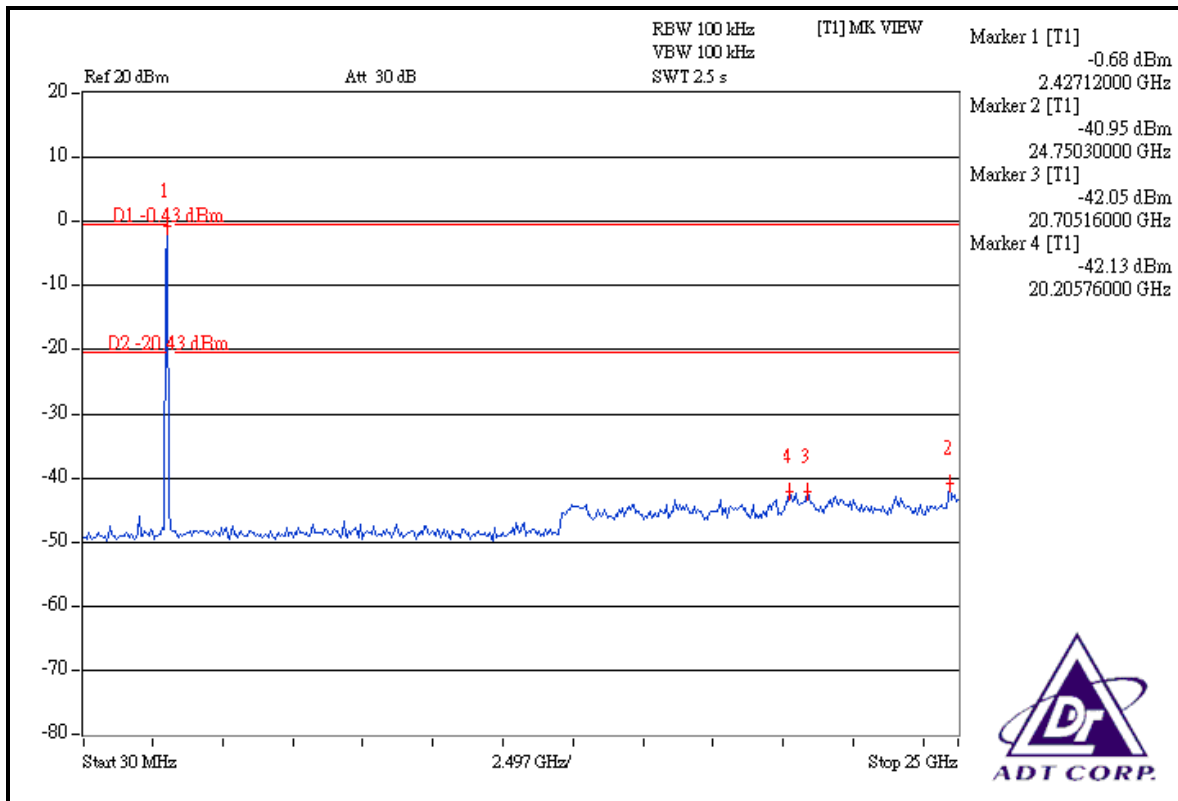
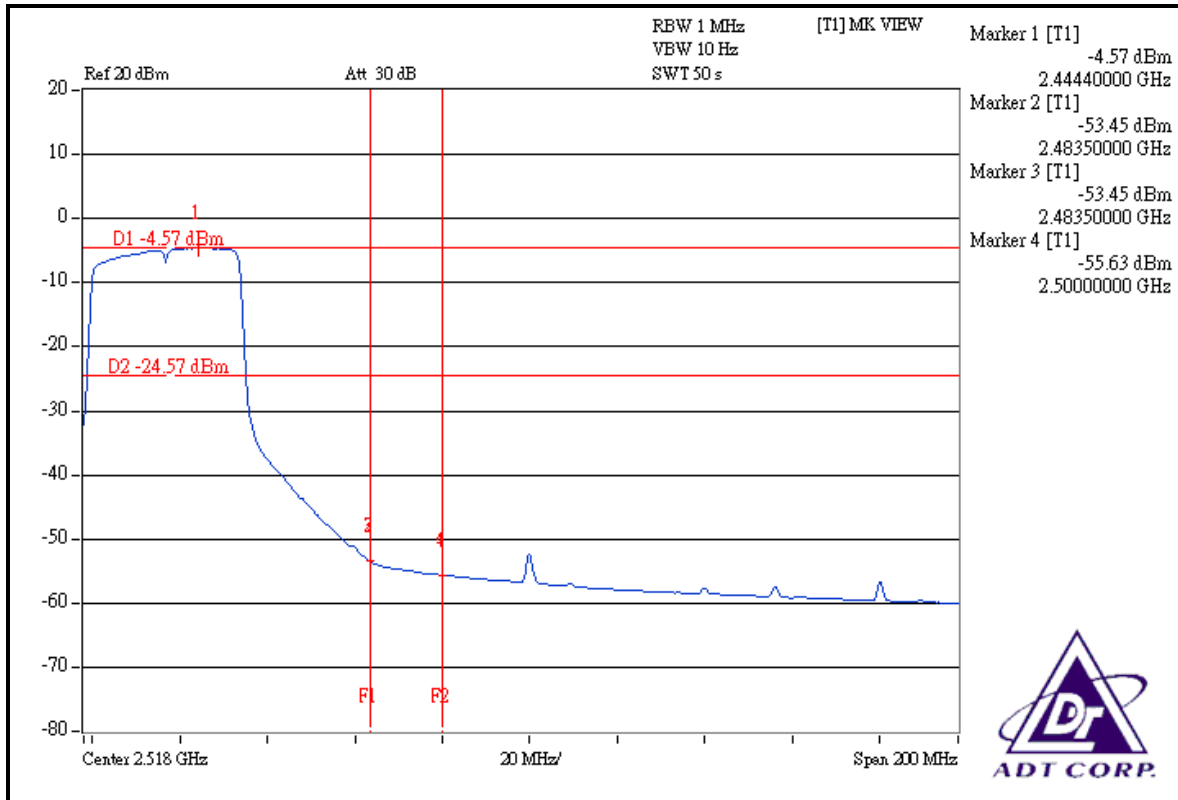



4.7 ANTENNA REQUIREMENT

4.7.1 STANDARD APPLICABLE

For intentional device, according to FCC 47 CFR Section 15.203, an intentional radiator shall be designed to ensure that no antenna other than that furnished by the responsible party shall be used with the device.

And according to FCC 47 CFR Section 15.247 (b), if transmitting antennas of directional gain greater than 6dBi are used, the power shall be reduced by the amount in dB that the directional gain of the antenna exceeds 6dBi.

4.7.2 ANTENNA CONNECTED CONSTRUCTION

The antenna used in this product is PIFA antenna without antenna connector. The maximum Gain of the antenna is 0dBi.



5 PHOTOGRAPHS OF THE TEST CONFIGURATION

Please refer to the attached file (Test Setup Photo).



6 INFORMATION ON THE TESTING LABORATORIES

We, ADT Corp., were founded in 1988 to provide our best service in EMC, Radio, Telecom and Safety consultation. Our laboratories are accredited and approved by the following approval agencies according to ISO/IEC 17025

USA	FCC, UL, A2LA
Germany	TUV Rheinland
Japan	VCCI
Norway	NEMKO
Canada	INDUSTRY CANADA , CSA
R.O.C.	CNLA, BSMI, NCC
Netherlands	Telefication
Singapore	PSB , GOST-ASIA(MOU)
Russia	CERTIS(MOU)

Copies of accreditation certificates of our laboratories obtained from approval agencies can be downloaded from our web site:

www.adt.com.tw/index.5/phtml. If you have any comments, please feel free to contact us at the following:

Linko EMC/RF Lab:

Tel: 886-2-26052180

Fax: 886-2-26051924

Hsin Chu EMC/RF Lab:

Tel: 886-3-5935343

Fax: 886-3-5935342

Hwa Ya EMC/RF/Safety/Telecom Lab:

Tel: 886-3-3183232

Fax: 886-3-3185050

Web Site: www.adt.com.tw

The address and road map of all our labs can be found in our web site also.



APPENDIX-A

MODIFICATIONS RECORDERS FOR ENGINEERING CHANGES TO THE EUT BY THE LAB

No any modifications are made to the EUT by the lab during the test.