



FCC TEST REPORT

REPORT NO.: RF950922L12

MODEL NO.: DWA-643

RECEIVED: Nov. 03, 2006

TESTED: Nov. 03 ~ 16, 2006

ISSUED: Nov. 20, 2006

APPLICANT: D-Link Corporation

ADDRESS: 17595 Mt. Herrmann, Fountain Valley, CA
92708, U.S.A.

ISSUED BY: Advance Data Technology Corporation

LAB ADDRESS: 47 14th Lin, Chiapau Tsun, Linko, Taipei, Taiwan,
R.O.C.

TEST LOCATION: No. 19, Hwa Ya 2nd Rd., Kueishan, Taoyuan,
Taiwan, R.O.C.

This test report consists of 112 pages in total. It may be duplicated completely for legal use with the approval of the applicant. It should not be reproduced except in full, without the written approval of our laboratory. The client should not use it to claim product endorsement by CNLA, A2LA or any government agencies. The test results in the report only apply to the tested sample.





TABLE OF CONTENTS

1.	CERTIFICATION	4
2.	SUMMARY OF TEST RESULTS	5
2.1	MEASUREMENT UNCERTAINTY	5
3.	GENERAL INFORMATION	6
3.1	GENERAL DESCRIPTION OF EUT	6
3.2	DESCRIPTION OF TEST MODES	7
3.2.1	CONFIGURATION OF SYSTEM UNDER TEST	7
3.2.2	TEST MODE APPLICABILITY AND TESTED CHANNEL DETAIL	8
3.3	GENERAL DESCRIPTION OF APPLIED STANDARDS	10
3.4	DESCRIPTION OF SUPPORT UNITS	11
4.	TEST TYPES AND RESULTS	12
4.1	CONDUCTED EMISSION MEASUREMENT	12
4.1.1	LIMITS OF CONDUCTED EMISSION MEASUREMENT	12
4.1.2	TEST INSTRUMENTS	12
4.1.3	TEST PROCEDURES	13
4.1.4	DEVIATION FROM TEST STANDARD	13
4.1.5	TEST SETUP	14
4.1.6	EUT OPERATING CONDITIONS	14
4.1.7	TEST RESULTS	15
4.2	RADIATED EMISSION MEASUREMENT	33
4.2.1	LIMITS OF RADIATED EMISSION MEASUREMENT	33
4.2.2	TEST INSTRUMENTS	34
4.2.3	TEST PROCEDURES	35
4.2.4	DEVIATION FROM TEST STANDARD	35
4.2.5	TEST SETUP	36
4.2.6	EUT OPERATING CONDITIONS	36
4.2.7	TEST RESULTS	37
4.3	6dB BANDWIDTH MEASUREMENT	52
4.3.1	LIMITS OF 6dB BANDWIDTH MEASUREMENT	52
4.3.2	TEST INSTRUMENTS	52
4.3.3	TEST PROCEDURE	52
4.3.4	DEVIATION FROM TEST STANDARD	52
4.3.5	TEST SETUP	53
4.3.6	EUT OPERATING CONDITIONS	53
4.3.7	TEST RESULTS	54
4.4	MAXIMUM PEAK OUTPUT POWER	70
4.4.1	LIMITS OF MAXIMUM PEAK OUTPUT POWER MEASUREMENT	70
4.4.2	INSTRUMENTS	70
4.4.3	TEST PROCEDURES	70
4.4.4	DEVIATION FROM TEST STANDARD	70
4.4.5	TEST SETUP	71
4.4.6	EUT OPERATING CONDITIONS	71



4.4.7	TEST RESULTS	72
4.5	POWER SPECTRAL DENSITY MEASUREMENT.....	74
4.5.1	LIMITS OF POWER SPECTRAL DENSITY MEASUREMENT	74
4.5.2	TEST INSTRUMENTS.....	74
4.5.3	TEST PROCEDURE	74
4.5.4	DEVIATION FROM TEST STANDARD.....	74
4.5.5	TEST SETUP	75
4.5.6	EUT OPERATING CONDITION.....	75
4.5.7	TEST RESULTS	76
4.6	BAND EDGES MEASUREMENT	92
4.6.1	LIMITS OF BAND EDGES MEASUREMENT	92
4.6.2	TEST INSTRUMENTS.....	92
4.6.3	TEST PROCEDURE	93
4.6.4	DEVIATION FROM TEST STANDARD.....	93
4.6.5	EUT OPERATING CONDITION.....	93
4.6.6	TEST RESULTS	94
4.7	ANTENNA REQUIREMENT	110
4.7.1	STANDARD APPLICABLE	110
4.7.2	ANTENNA CONNECTED CONSTRUCTION.....	110
6.	INFORMATION ON THE TESTING LABORATORIES	111
APPENDIX-A	A-1



1. CERTIFICATION

PRODUCT : D-Link DWA-643 Xtreme N™ ExpressCard Notebook Adapter

MODEL NO.: DWA-643

BRAND: D-Link

APPLICANT : D-Link Corporation

TESTED: Nov. 03 ~ 16, 2006

TEST SAMPLE: ENGINEERING SAMPLE

STANDARDS : FCC Part 15, Subpart C (Section 15.247),
ANSI C63.4-2003

The above equipment has been tested by **Advance Data Technology Corporation**, and found compliance with the requirement of the above standards. The test record, data evaluation & Equipment Under Test (EUT) configurations represented herein are true and accurate accounts of the measurements of the sample's EMC characteristics under the conditions specified in this report.

PREPARED BY : Rennie Wang , **DATE:** Nov. 20, 2006
Rennie Wang

TECHNICAL
ACCEPTANCE : Long Chen , **DATE:** Nov. 20, 2006
Responsible for RF Long Chen

APPROVED BY : Gary Chang , **DATE:** Nov. 20, 2006
Gary Chang / Supervisor

2. SUMMARY OF TEST RESULTS

The EUT has been tested according to the following specifications:

APPLIED STANDARD: FCC Part 15, Subpart C			
STANDARD SECTION	TEST TYPE AND LIMIT	RESULT	REMARK
15.207	AC Power Conducted Emission	PASS	Meet the requirement of limit. Minimum passing margin is -9.90dB at 0.185MHz.
15.247(a)(2)	Spectrum Bandwidth of a Direct Sequence Spread Spectrum System Limit : min. 500kHz	PASS	Meet the requirement of limit.
15.247(b)	Maximum Peak Output Power Limit: max. 30dBm	PASS	Meet the requirement of limit.
15.247(d)	Transmitter Radiated Emissions Limit: Table 15.209	PASS	Meet the requirement of limit. Minimum passing margin is -1.04dB at 2390.00 & 4874.00MHz.
15.247(e)	Power Spectral Density Limit: max. 8dBm	PASS	Meet the requirement of limit.
15.247(d)	Band Edge Measurement Limit: 20dB less than the peak value of fundamental frequency	PASS	Meet the requirement of limit.

2.1 MEASUREMENT UNCERTAINTY

Where relevant, the following measurement uncertainty levels have been estimated for tests performed on the EUT as specified in CISPR 16-4:

MEASUREMENT	FREQUENCY	UNCERTAINTY
Conducted emissions	9kHz ~ 30MHz	2.44dB
Radiated emissions	30MHz ~ 200MHz	3.59dB
	200MHz ~ 1000MHz	3.61dB
	1GHz ~ 18GHz	2.26dB
	18GHz ~ 40GHz	1.94dB

This uncertainty represents an expanded uncertainty expressed at approximately the 95% confidence level using a coverage factor of $k = 2$.

3. GENERAL INFORMATION

3.1 GENERAL DESCRIPTION OF EUT

PRODUCT	D-Link DWA-643 Xtreme N™ ExpressCard Notebook Adapter
MODEL NO.	DWA-643
FCC ID	KA2WA643A1
POWER SUPPLY	3.3Vdc from host equipment
MODULATION TYPE	CCK, DQPSK, DBPSK for DSSS 64QAM, 16QAM, QPSK, BPSK for OFDM
MODULATION TECHNOLOGY	DSSS, OFDM
TRANSFER RATE	802.11b: 11/ 5.5/ 2/ 1Mbps 802.11g: 54/ 48/ 36/ 24/ 18/ 12/ 9/ 6Mbps Draft 802.11n (20MHz): 144.444/ 130.000/ 115.556/ 86.667/ 57.778/ 43.333/ 28.889/ 14.444/ 72.2/ 65.0/ 57.8/ 43.3/ 28.9/ 21.7/ 14.4/ 7.2Mbps Draft 802.11n (40MHz): 300/ 270/ 240/ 180/ 120/ 90/ 60/ 30/ 150/ 135/ 120/ 90/ 60/ 45/ 30/ 15Mbps
FREQUENCY RANGE	2412MHz ~ 2462MHz
NUMBER OF CHANNEL	11 for 802.11b, 802.11g and draft 802.11n (20MHz) 7 for draft 802.11n (40MHz)
MAXIMUM OUTPUT POWER	140.170mW
ANTENNA TYPE	PIFA antenna with 2dBi gain
DATA CABLE	NA
I/O PORTS	NA

NOTE:

1. The EUT incorporates a MIMO function with 802.11b, 802.11g and draft 802.11n. Physically, the card provides two completed transmitters and two receivers.
2. The EUT is 2 * 2 spatial MIMO (2Tx & 2Rx) without beam forming function that only operate dual chain configuration (both chain 0 and chain 1 transceivers are operational).
3. When the EUT operating in 802.11b and 802.11g, the software operation, which is defined by manufacturer, only set dual Tx.
4. When the EUT operating in draft 802.11n, the software operation, which is defined by manufacturer, only set 0 ~ 15 of "MCS" (MCS: Modulation and Coding Schemes) for dual Tx.
5. The EUT complies with draft 802.11n standards and backwards compatible with 802.11b, 802.11g products.
6. The EUT operates in the 2.4GHz frequency spectrum with throughput of up to 300Mbps.
7. The above EUT information was declared by manufacturer and for more detailed features description, please refer to the manufacturer's specifications or user's manual.

3.2 DESCRIPTION OF TEST MODES

Eleven channels are provided for 802.11b, 802.11g and draft 802.11n (20MHz):

CHANNEL	FREQUENCY	CHANNEL	FREQUENCY
1	2412MHz	7	2442MHz
2	2417MHz	8	2447MHz
3	2422MHz	9	2452MHz
4	2427MHz	10	2457MHz
5	2432MHz	11	2462MHz
6	2437MHz		

Seven channels are provided for draft 802.11n (40MHz):

CHANNEL	FREQUENCY	CHANNEL	FREQUENCY
1	2422MHz	5	2442MHz
2	2427MHz	6	2447MHz
3	2432MHz	7	2452MHz
4	2437MHz		

3.2.1 CONFIGURATION OF SYSTEM UNDER TEST

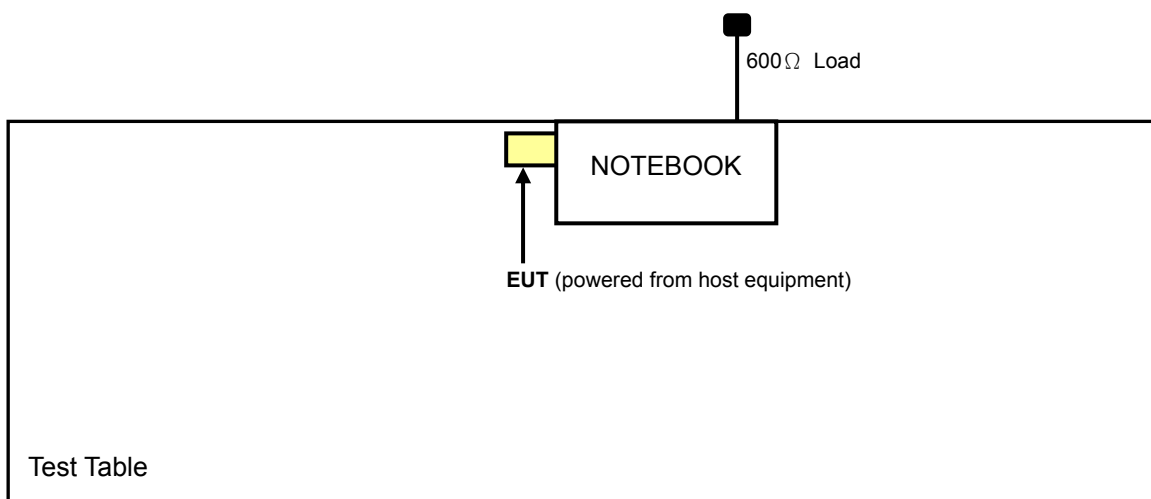

3.2.2 TEST MODE APPLICABILITY AND TESTED CHANNEL DETAIL

EUT CONFIGURE MODE	APPLICABLE TO				DESCRIPTION
	PLC	RE < 1G	RE ≥ 1G	APCM	
-	√	√	√	√	-

Where **PLC**: Power Line Conducted Emission **RE < 1G**: Radiated Emission below 1GHz
RE ≥ 1G: Radiated Emission above 1GHz **APCM**: Antenna Port Conducted Measurement

POWER LINE CONDUCTED EMISSION TEST:

- Pre-Scan has been conducted to determine the worst-case mode from all possible combinations between available modulations, data rates and antenna ports (if EUT with antenna diversity architecture).
- Following channel(s) was (were) selected for the final test as listed below.

MODE	AVAILABLE CHANNEL	TESTED CHANNEL	MODULATION TECHNOLOGY	MODULATION TYPE	DATA RATE (Mbps)	TX CONDITION
802.11g	1 to 11	1, 6, 11	OFDM	BPSK	6.0	Dual
Draft 802.11n (20MHz)	1 to 11	1, 6, 11	OFDM	BPSK	7.2	Dual
Draft 802.11n (40MHz)	1 to 7	1, 4, 7	OFDM	BPSK	15.0	Dual

RADIATED EMISSION TEST (BELOW 1 GHz):

- Pre-Scan has been conducted to determine the worst-case mode from all possible combinations between available modulations, data rates and antenna ports (if EUT with antenna diversity architecture).
- Following channel(s) was (were) selected for the final test as listed below.

MODE	AVAILABLE CHANNEL	TESTED CHANNEL	MODULATION TECHNOLOGY	MODULATION TYPE	DATA RATE (Mbps)	TX CONDITION
802.11g	1 to 11	1	OFDM	BPSK	6.0	Dual
Draft 802.11n (20MHz)	1 to 11	1	OFDM	BPSK	7.2	Dual
Draft 802.11n (40MHz)	1 to 7	1	OFDM	BPSK	15.0	Dual



RADIATED EMISSION TEST (ABOVE 1 GHz):

- Pre-Scan has been conducted to determine the worst-case mode from all possible combinations between available modulations, data rates and antenna ports (if EUT with antenna diversity architecture).
- Following channel(s) was (were) selected for the final test as listed below.

MODE	AVAILABLE CHANNEL	TESTED CHANNEL	MODULATION TECHNOLOGY	MODULATION TYPE	DATA RATE (Mbps)	TX CONDITION
802.11b	1 to 11	1, 6, 11	DSSS	DBPSK	1.0	Dual
802.11g	1 to 11	1, 6, 11	OFDM	BPSK	6.0	Dual
Draft 802.11n (20MHz)	1 to 11	1, 6, 11	OFDM	BPSK	7.2	Dual
Draft 802.11n (40MHz)	1 to 7	1, 4, 7	OFDM	BPSK	15.0	Dual

BANDEDGE MEASUREMENT:

- Pre-Scan has been conducted to determine the worst-case mode from all possible combinations between available modulations, data rates and antenna ports (if EUT with antenna diversity architecture).
- Following channel(s) was (were) selected for the final test as listed below.

MODE	AVAILABLE CHANNEL	TESTED CHANNEL	MODULATION TECHNOLOGY	MODULATION TYPE	DATA RATE (Mbps)	TX CONDITION
802.11b	1 to 11	1, 11	DSSS	DBPSK	1.0	Dual
802.11g	1 to 11	1, 11	OFDM	BPSK	6.0	Dual
Draft 802.11n (20MHz)	1 to 11	1, 11	OFDM	BPSK	7.2	Dual
Draft 802.11n (40MHz)	1 to 7	1, 7	OFDM	BPSK	15.0	Dual

ANTENNA PORT CONDUCTED MEASUREMENT:

- Pre-Scan has been conducted to determine the worst-case mode from all possible combinations between available modulations, data rates and antenna ports (if EUT with antenna diversity architecture).
- Following channel(s) was (were) selected for the final test as listed below.

MODE	AVAILABLE CHANNEL	TESTED CHANNEL	MODULATION TECHNOLOGY	MODULATION TYPE	DATA RATE (Mbps)	TX CONDITION
802.11b	1 to 11	1, 6, 11	DSSS	DBPSK	1.0	Dual
802.11g	1 to 11	1, 6, 11	OFDM	BPSK	6.0	Dual
Draft 802.11n (20MHz)	1 to 11	1, 6, 11	OFDM	BPSK	7.2	Dual
Draft 802.11n (40MHz)	1 to 7	1, 4, 7	OFDM	BPSK	15.0	Dual



3.3 GENERAL DESCRIPTION OF APPLIED STANDARDS

The EUT is a RF product. According to the specifications of the manufacturer, it must comply with the requirements of the following standards:

FCC Part 15, Subpart C. (15.247)

ANSI C63.4-2003

All test items have been performed and recorded as per the above standards.

NOTE: The EUT is also considered as a kind of computer peripheral, because the connection to computer is necessary for typical use. It has been verified to comply with the requirements of FCC Part 15, Subpart B, Class B (DoC). The test report has been issued separately.



3.4 DESCRIPTION OF SUPPORT UNITS

The EUT has been tested as an independent unit together with other necessary accessories or support units. The following support units or accessories were used to form a representative test configuration during the tests.

NO.	PRODUCT	BRAND	MODEL NO.	SERIAL NO.	FCC ID
1	NOTEBOOK	HP	nx6215	CND5390CMP	FCC DoC Approved

NO.	SIGNAL CABLE DESCRIPTION OF THE ABOVE SUPPORT UNITS
1	NA

NOTE: All power cords of the above support units are non shielded (1.8m).



4. TEST TYPES AND RESULTS

4.1 CONDUCTED EMISSION MEASUREMENT

4.1.1 LIMITS OF CONDUCTED EMISSION MEASUREMENT

FREQUENCY OF EMISSION (MHz)	CONDUCTED LIMIT (dB μ V)	
	Quasi-peak	Average
0.15-0.5	66 to 56	56 to 46
0.5-5	56	46
5-30	60	50

- NOTE:**
1. The lower limit shall apply at the transition frequencies.
 2. The limit decreases in line with the logarithm of the frequency in the range of 0.15 to 0.50 MHz.
 3. All emanations from a class A/B digital device or system, including any network of conductors and apparatus connected thereto, shall not exceed the level of field strengths specified above.

4.1.2 TEST INSTRUMENTS

DESCRIPTION & MANUFACTURER	MODEL NO.	SERIAL NO.	CALIBRATED UNTIL
Test Receiver ROHDE & SCHWARZ	ESCS30	100288	Sep. 25, 2007
RF signal cable Woken	5D-FB	Cable-HYCO3-01	Jan. 06, 2007
LISN ROHDE & SCHWARZ	ESH2-Z5	100100	Jan. 09, 2007
LISN ROHDE & SCHWARZ	ESH3-Z5	100311	Jan. 22, 2007
Software ADT	ADT_Cond_V3	NA	NA

- NOTE:**
1. The calibration interval of the above test instruments is 12 months and the calibrations are traceable to NML/ROC and NIST/USA.
 2. The test was performed in HwaYa Shielded Room 2.
 3. The VCCI Site Registration No. is C-2047.

4.1.3 TEST PROCEDURES

- a. The EUT was placed 0.4 meters from the conducting wall of the shielded room with EUT being connected to the power mains through a line impedance stabilization network (LISN). Other support units were connected to the power mains through another LISN. The two LISNs provide 50 ohm/ 50uH of coupling impedance for the measuring instrument.
- b. Both lines of the power mains connected to the EUT were checked for maximum conducted interference.
- c. The frequency range from 150kHz to 30MHz was searched. Emission levels under (Limit - 20dB) was not recorded.

4.1.4 DEVIATION FROM TEST STANDARD

No deviation

4.1.5 TEST SETUP

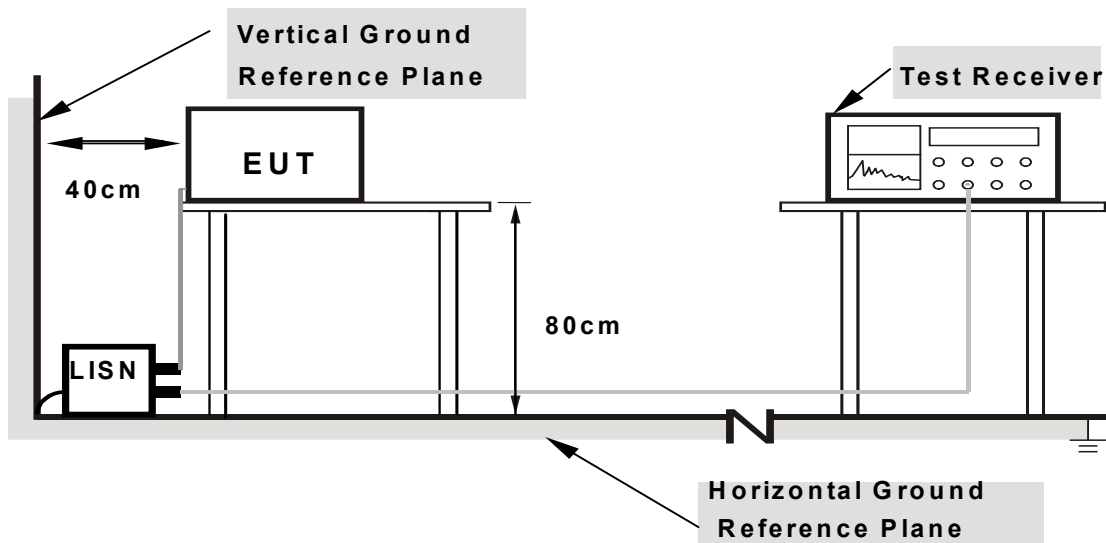

- Note:**
1. Support units were connected to second LISN.
 2. Both of LISNs (AMN) are 80 cm from EUT and at least 80 from other units and other metal planes

For the actual test configuration, please refer to the attached file (Test Setup Photo).

4.1.6 EUT OPERATING CONDITIONS

- a. Connected the EUT to notebook and placed on a testing table.
- b. The notebook ran a test program (provided by manufacturer) to enable EUT under transmission/receiving condition continuously at specific channel frequency.
- c. The notebook enable the EUT in full functions.

4.1.7 TEST RESULTS

CONDUCTED WORST-CASE DATA: 802.11g OFDM MODULATION: DUAL TX

EUT TEST CONDITION		MEASUREMENT DETAIL	
CHANNEL	Channel 1	PHASE	Line 1
MODULATION TYPE	BPSK	6dB BANDWIDTH	9 kHz
TRANSFER RATE	6.0Mbps	INPUT POWER (SYSTEM)	120Vac, 60 Hz
ENVIRONMENTAL CONDITIONS	20deg. C, 60%RH, 991hPa	TESTED BY	Match Tsui

No	Freq. [MHz]	Corr. Factor (dB)	Reading Value		Emission Level		Limit		Margin	
			[dB (uV)]		[dB (uV)]		[dB (uV)]		(dB)	
			Q.P.	AV.	Q.P.	AV.	Q.P.	AV.	Q.P.	AV.
1	0.189	0.10	53.02	-	53.12	-	64.08	54.08	-10.96	-
2	0.275	0.10	43.82	-	43.92	-	60.97	50.97	-17.05	-
3	0.435	0.10	34.35	-	34.45	-	57.15	47.15	-22.70	-
4	1.516	0.15	29.66	-	29.81	-	56.00	46.00	-26.19	-
5	4.652	0.37	25.54	-	25.91	-	56.00	46.00	-30.09	-
6	18.289	0.58	27.38	-	27.96	-	60.00	50.00	-32.04	-

- REMARKS:**
1. Q.P. and AV. are abbreviations of quasi-peak and average individually.
 2. "-": The Quasi-peak reading value also meets average limit and measurement with the average detector is unnecessary.
 3. The emission levels of other frequencies were very low against the limit.
 4. Margin value = Emission level - Limit value
 5. Correction factor = Insertion loss + Cable loss
 6. Emission Level = Correction Factor + Reading Value.

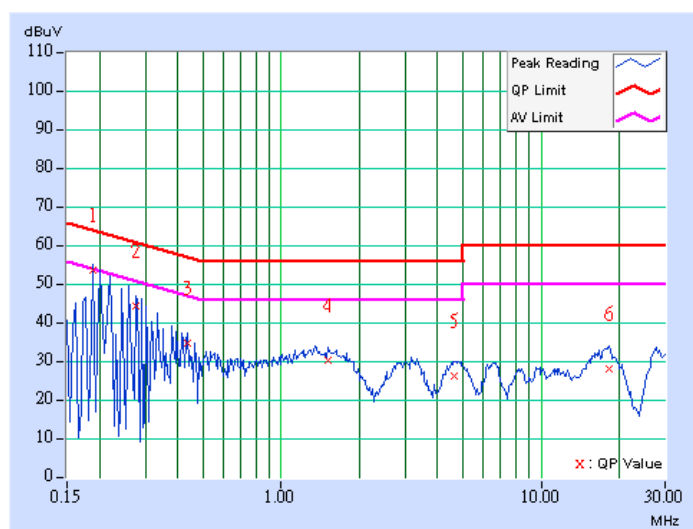

EUT TEST CONDITION		MEASUREMENT DETAIL	
CHANNEL	Channel 1	PHASE	Line 2
MODULATION TYPE	BPSK	6dB BANDWIDTH	9 kHz
TRANSFER RATE	6.0Mbps	INPUT POWER (SYSTEM)	120Vac, 60 Hz
ENVIRONMENTAL CONDITIONS	20deg. C, 60%RH, 991hPa	TESTED BY	Match Tsui

No	Freq. [MHz]	Corr. Factor (dB)	Reading Value [dB (uV)]		Emission Level [dB (uV)]		Limit [dB (uV)]		Margin (dB)	
			Q.P.	AV.	Q.P.	AV.	Q.P.	AV.	Q.P.	AV.
1	0.185	0.10	54.25	35.95	54.35	36.05	64.25	54.25	-9.90	-18.20
2	0.271	0.10	46.24	-	46.34	-	61.08	51.08	-14.74	-
3	0.392	0.10	36.24	-	36.34	-	58.02	48.02	-21.68	-
4	1.906	0.20	24.81	-	25.01	-	56.00	46.00	-30.99	-
5	4.051	0.37	22.90	-	23.27	-	56.00	46.00	-32.73	-
6	17.867	0.59	27.37	-	27.96	-	60.00	50.00	-32.04	-

- REMARKS:**
1. Q.P. and AV. are abbreviations of quasi-peak and average individually.
 2. "-": The Quasi-peak reading value also meets average limit and measurement with the average detector is unnecessary.
 3. The emission levels of other frequencies were very low against the limit.
 4. Margin value = Emission level - Limit value
 5. Correction factor = Insertion loss + Cable loss
 6. Emission Level = Correction Factor + Reading Value.

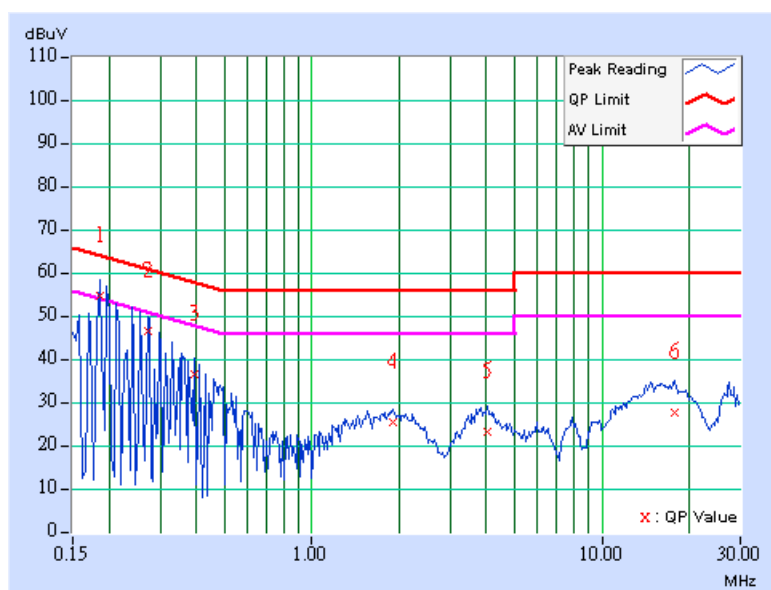

EUT TEST CONDITION		MEASUREMENT DETAIL	
CHANNEL	Channel 6	PHASE	Line 1
MODULATION TYPE	BPSK	6dB BANDWIDTH	9 kHz
TRANSFER RATE	6.0Mbps	INPUT POWER (SYSTEM)	120Vac, 60 Hz
ENVIRONMENTAL CONDITIONS	20deg. C, 60%RH, 991hPa	TESTED BY	Match Tsui

No	Freq. [MHz]	Corr. Factor (dB)	Reading Value [dB (uV)]		Emission Level [dB (uV)]		Limit [dB (uV)]		Margin (dB)	
			Q.P.	AV.	Q.P.	AV.	Q.P.	AV.	Q.P.	AV.
			1	0.224	0.10	45.34	-	45.44	-	62.66
2	0.295	0.10	39.67	-	39.77	-	60.40	50.40	-20.63	-
3	0.474	0.10	30.96	-	31.06	-	56.44	46.44	-25.38	-
4	1.527	0.15	29.08	-	29.23	-	56.00	46.00	-26.77	-
5	4.625	0.37	25.35	-	25.72	-	56.00	46.00	-30.28	-
6	17.820	0.59	27.39	-	27.98	-	60.00	50.00	-32.02	-

- REMARKS:**
1. Q.P. and AV. are abbreviations of quasi-peak and average individually.
 2. "-": The Quasi-peak reading value also meets average limit and measurement with the average detector is unnecessary.
 3. The emission levels of other frequencies were very low against the limit.
 4. Margin value = Emission level - Limit value
 5. Correction factor = Insertion loss + Cable loss
 6. Emission Level = Correction Factor + Reading Value.

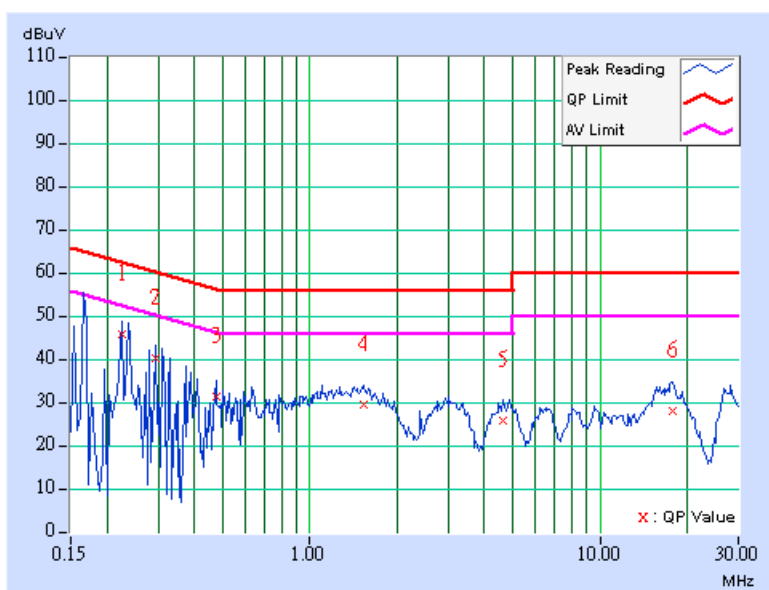

EUT TEST CONDITION		MEASUREMENT DETAIL	
CHANNEL	Channel 6	PHASE	Line 2
MODULATION TYPE	BPSK	6dB BANDWIDTH	9 kHz
TRANSFER RATE	6.0Mbps	INPUT POWER (SYSTEM)	120Vac, 60 Hz
ENVIRONMENTAL CONDITIONS	20deg. C, 60%RH, 991hPa	TESTED BY	Match Tsui

No	Freq. [MHz]	Corr. Factor (dB)	Reading Value [dB (uV)]		Emission Level [dB (uV)]		Limit [dB (uV)]		Margin (dB)	
			Q.P.	AV.	Q.P.	AV.	Q.P.	AV.	Q.P.	AV.
			1	0.220	0.10	46.49	-	46.59	-	62.81
2	0.310	0.10	38.92	-	39.02	-	59.97	49.97	-20.95	-
3	0.474	0.11	30.41	-	30.52	-	56.44	46.44	-25.92	-
4	2.074	0.21	23.01	-	23.22	-	56.00	46.00	-32.78	-
5	3.918	0.36	20.38	-	20.74	-	56.00	46.00	-35.26	-
6	15.859	0.62	28.59	-	29.21	-	60.00	50.00	-30.79	-

- REMARKS:**
1. Q.P. and AV. are abbreviations of quasi-peak and average individually.
 2. "-": The Quasi-peak reading value also meets average limit and measurement with the average detector is unnecessary.
 3. The emission levels of other frequencies were very low against the limit.
 4. Margin value = Emission level - Limit value
 5. Correction factor = Insertion loss + Cable loss
 6. Emission Level = Correction Factor + Reading Value.

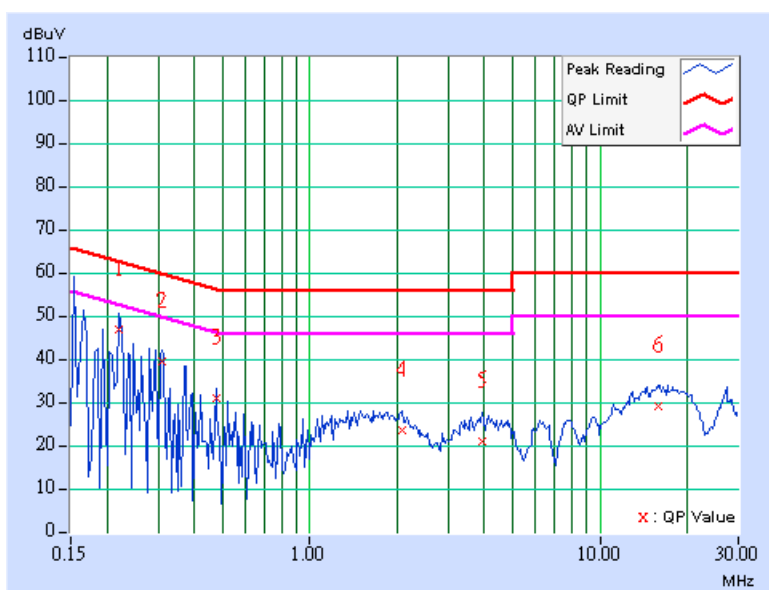

EUT TEST CONDITION		MEASUREMENT DETAIL	
CHANNEL	Channel 11	PHASE	Line 1
MODULATION TYPE	BPSK	6dB BANDWIDTH	9 kHz
TRANSFER RATE	6.0Mbps	INPUT POWER (SYSTEM)	120Vac, 60 Hz
ENVIRONMENTAL CONDITIONS	20deg. C, 60%RH, 991hPa	TESTED BY	Match Tsui

No	Freq. [MHz]	Corr. Factor (dB)	Reading Value [dB (uV)]		Emission Level [dB (uV)]		Limit [dB (uV)]		Margin (dB)	
			Q.P.	AV.	Q.P.	AV.	Q.P.	AV.	Q.P.	AV.
			1	0.185	0.10	51.89	-	51.99	-	64.25
2	0.271	0.10	41.18	-	41.28	-	61.08	51.08	-19.80	-
3	0.377	0.10	35.58	-	35.68	-	58.35	48.35	-22.67	-
4	1.402	0.14	28.96	-	29.10	-	56.00	46.00	-26.90	-
5	2.816	0.27	24.64	-	24.91	-	56.00	46.00	-31.09	-
6	16.766	0.61	27.48	-	28.09	-	60.00	50.00	-31.91	-

- REMARKS:**
1. Q.P. and AV. are abbreviations of quasi-peak and average individually.
 2. "-": The Quasi-peak reading value also meets average limit and measurement with the average detector is unnecessary.
 3. The emission levels of other frequencies were very low against the limit.
 4. Margin value = Emission level - Limit value
 5. Correction factor = Insertion loss + Cable loss
 6. Emission Level = Correction Factor + Reading Value.

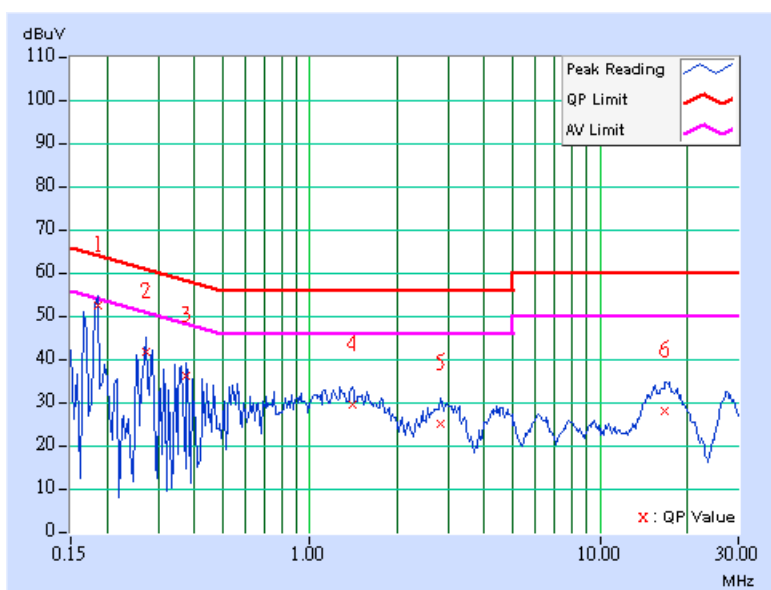

EUT TEST CONDITION		MEASUREMENT DETAIL	
CHANNEL	Channel 11	PHASE	Line 2
MODULATION TYPE	BPSK	6dB BANDWIDTH	9 kHz
TRANSFER RATE	6.0Mbps	INPUT POWER (SYSTEM)	120Vac, 60 Hz
ENVIRONMENTAL CONDITIONS	20deg. C, 60%RH, 991hPa	TESTED BY	Match Tsui

No	Freq. [MHz]	Corr. Factor (dB)	Reading Value [dB (uV)]		Emission Level [dB (uV)]		Limit [dB (uV)]		Margin (dB)	
			Q.P.	AV.	Q.P.	AV.	Q.P.	AV.	Q.P.	AV.
			1	0.177	0.10	52.35	-	52.45	-	64.61
2	0.267	0.10	42.17	-	42.27	-	61.20	51.20	-18.93	-
3	0.455	0.11	29.69	-	29.80	-	56.79	46.79	-26.99	-
4	1.566	0.20	22.54	-	22.74	-	56.00	46.00	-33.26	-
5	4.527	0.38	21.02	-	21.40	-	56.00	46.00	-34.60	-
6	17.383	0.60	26.86	-	27.46	-	60.00	50.00	-32.54	-

- REMARKS:**
1. Q.P. and AV. are abbreviations of quasi-peak and average individually.
 2. "-": The Quasi-peak reading value also meets average limit and measurement with the average detector is unnecessary.
 3. The emission levels of other frequencies were very low against the limit.
 4. Margin value = Emission level - Limit value
 5. Correction factor = Insertion loss + Cable loss
 6. Emission Level = Correction Factor + Reading Value.

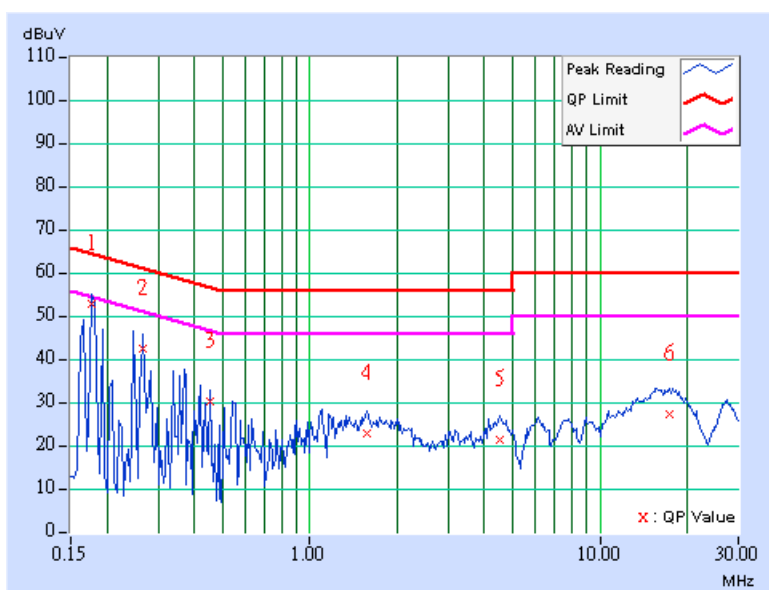

DRAFT 802.11n (20MHz) OFDM MODULATION: DUAL TX

EUT TEST CONDITION		MEASUREMENT DETAIL	
CHANNEL	Channel 1	PHASE	Line 1
MODULATION TYPE	BPSK	6dB BANDWIDTH	9 kHz
TRANSFER RATE	7.2Mbps	INPUT POWER (SYSTEM)	120Vac, 60 Hz
ENVIRONMENTAL CONDITIONS	20deg. C, 60%RH, 991hPa	TESTED BY	Match Tsui

No	Freq. [MHz]	Corr. Factor (dB)	Reading Value [dB (uV)]		Emission Level [dB (uV)]		Limit [dB (uV)]		Margin (dB)	
			Q.P.	AV.	Q.P.	AV.	Q.P.	AV.	Q.P.	AV.
1	0.193	0.10	50.08	-	50.18	-	63.91	53.91	-13.73	-
2	0.295	0.10	39.97	-	40.07	-	60.40	50.40	-20.33	-
3	0.380	0.10	34.17	-	34.27	-	58.27	48.27	-24.00	-
4	1.371	0.14	28.78	-	28.92	-	56.00	46.00	-27.08	-
5	4.430	0.37	23.06	-	23.43	-	56.00	46.00	-32.57	-
6	16.684	0.61	27.11	-	27.72	-	60.00	50.00	-32.28	-

- REMARKS:**
1. Q.P. and AV. are abbreviations of quasi-peak and average individually.
 2. "-": The Quasi-peak reading value also meets average limit and measurement with the average detector is unnecessary.
 3. The emission levels of other frequencies were very low against the limit.
 4. Margin value = Emission level - Limit value
 5. Correction factor = Insertion loss + Cable loss
 6. Emission Level = Correction Factor + Reading Value.

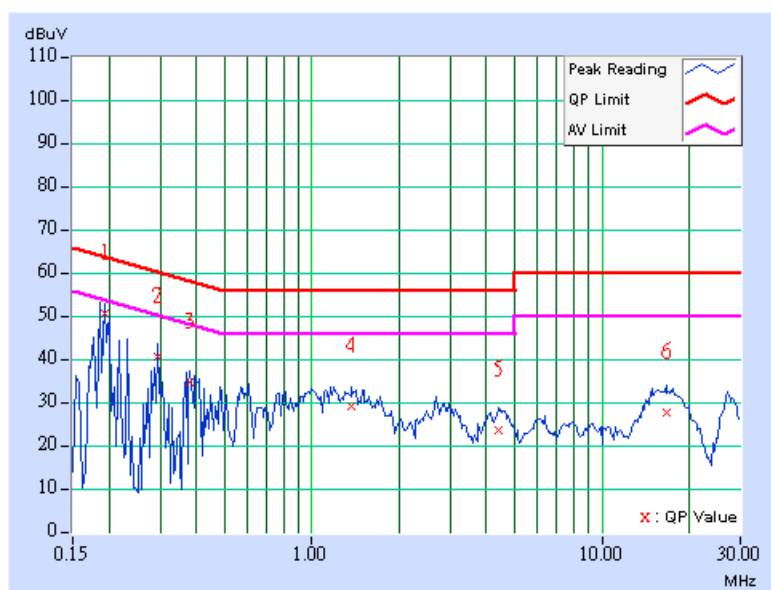

EUT TEST CONDITION		MEASUREMENT DETAIL	
CHANNEL	Channel 1	PHASE	Line 2
MODULATION TYPE	BPSK	6dB BANDWIDTH	9 kHz
TRANSFER RATE	7.2Mbps	INPUT POWER (SYSTEM)	120Vac, 60 Hz
ENVIRONMENTAL CONDITIONS	20deg. C, 60%RH, 991hPa	TESTED BY	Match Tsui

No	Freq. [MHz]	Corr. Factor (dB)	Reading Value [dB (uV)]		Emission Level [dB (uV)]		Limit [dB (uV)]		Margin (dB)	
			Q.P.	AV.	Q.P.	AV.	Q.P.	AV.	Q.P.	AV.
			1	0.193	0.10	49.96	-	50.06	-	63.91
2	0.287	0.10	40.61	-	40.71	-	60.62	50.62	-19.91	-
3	0.392	0.10	32.45	-	32.55	-	58.02	48.02	-25.47	-
4	1.316	0.20	23.03	-	23.23	-	56.00	46.00	-32.77	-
5	4.211	0.37	19.73	-	20.10	-	56.00	46.00	-35.90	-
6	15.984	0.62	26.89	-	27.51	-	60.00	50.00	-32.49	-

- REMARKS:**
1. Q.P. and AV. are abbreviations of quasi-peak and average individually.
 2. "-": The Quasi-peak reading value also meets average limit and measurement with the average detector is unnecessary.
 3. The emission levels of other frequencies were very low against the limit.
 4. Margin value = Emission level - Limit value
 5. Correction factor = Insertion loss + Cable loss
 6. Emission Level = Correction Factor + Reading Value.

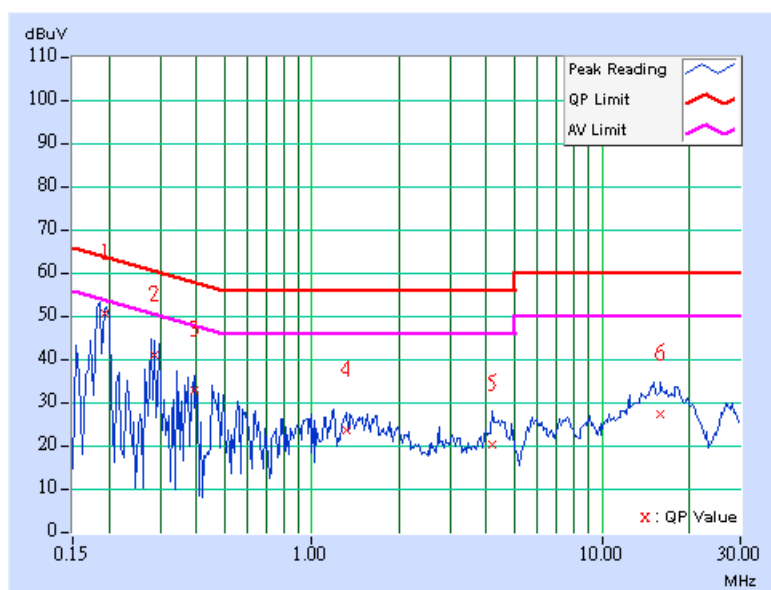

EUT TEST CONDITION		MEASUREMENT DETAIL	
CHANNEL	Channel 6	PHASE	Line 1
MODULATION TYPE	BPSK	6dB BANDWIDTH	9 kHz
TRANSFER RATE	7.2Mbps	INPUT POWER (SYSTEM)	120Vac, 60 Hz
ENVIRONMENTAL CONDITIONS	20deg. C, 60%RH, 991hPa	TESTED BY	Match Tsui

No	Freq. [MHz]	Corr. Factor (dB)	Reading Value [dB (uV)]		Emission Level [dB (uV)]		Limit [dB (uV)]		Margin (dB)	
			Q.P.	AV.	Q.P.	AV.	Q.P.	AV.	Q.P.	AV.
			1	0.209	0.10	48.85	-	48.95	-	63.25
2	0.304	0.10	38.95	-	39.05	-	60.12	50.12	-21.07	-
3	0.423	0.10	34.32	-	34.42	-	57.38	47.38	-22.96	-
4	1.270	0.13	29.07	-	29.20	-	56.00	46.00	-26.80	-
5	4.457	0.37	22.30	-	22.67	-	56.00	46.00	-33.33	-
6	16.109	0.61	27.49	-	28.10	-	60.00	50.00	-31.90	-

- REMARKS:**
1. Q.P. and AV. are abbreviations of quasi-peak and average individually.
 2. "-": The Quasi-peak reading value also meets average limit and measurement with the average detector is unnecessary.
 3. The emission levels of other frequencies were very low against the limit.
 4. Margin value = Emission level - Limit value
 5. Correction factor = Insertion loss + Cable loss
 6. Emission Level = Correction Factor + Reading Value.

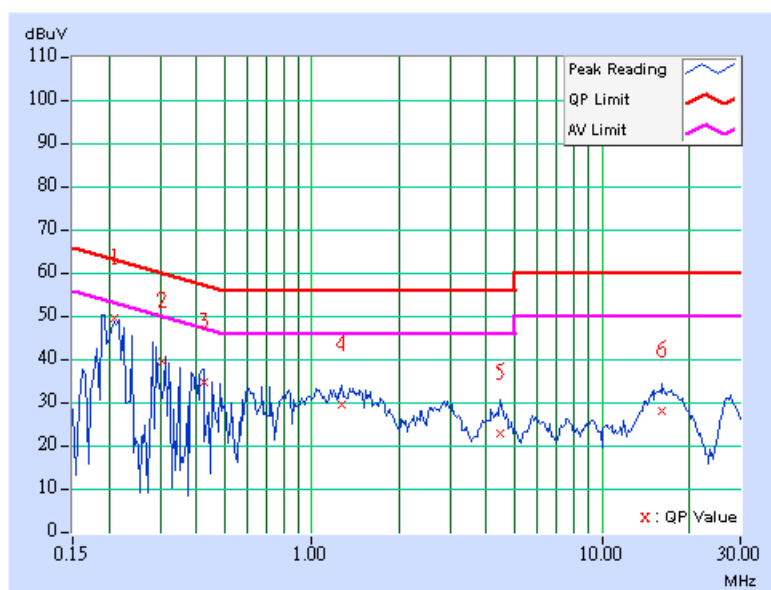

EUT TEST CONDITION		MEASUREMENT DETAIL	
CHANNEL	Channel 6	PHASE	Line 2
MODULATION TYPE	BPSK	6dB BANDWIDTH	9 kHz
TRANSFER RATE	7.2Mbps	INPUT POWER (SYSTEM)	120Vac, 60 Hz
ENVIRONMENTAL CONDITIONS	20deg. C, 60%RH, 991hPa	TESTED BY	Match Tsui

No	Freq. [MHz]	Corr. Factor (dB)	Reading Value [dB (uV)]		Emission Level [dB (uV)]		Limit [dB (uV)]		Margin (dB)	
			Q.P.	AV.	Q.P.	AV.	Q.P.	AV.	Q.P.	AV.
			1	0.197	0.10	49.14	-	49.24	-	63.74
2	0.298	0.10	40.10	-	40.20	-	60.29	50.29	-20.09	-
3	0.494	0.12	28.38	-	28.50	-	56.10	46.10	-27.61	-
4	1.352	0.20	23.18	-	23.38	-	56.00	46.00	-32.62	-
5	4.539	0.38	19.73	-	20.11	-	56.00	46.00	-35.89	-
6	16.484	0.61	26.43	-	27.04	-	60.00	50.00	-32.96	-

- REMARKS:**
1. Q.P. and AV. are abbreviations of quasi-peak and average individually.
 2. "-": The Quasi-peak reading value also meets average limit and measurement with the average detector is unnecessary.
 3. The emission levels of other frequencies were very low against the limit.
 4. Margin value = Emission level - Limit value
 5. Correction factor = Insertion loss + Cable loss
 6. Emission Level = Correction Factor + Reading Value.

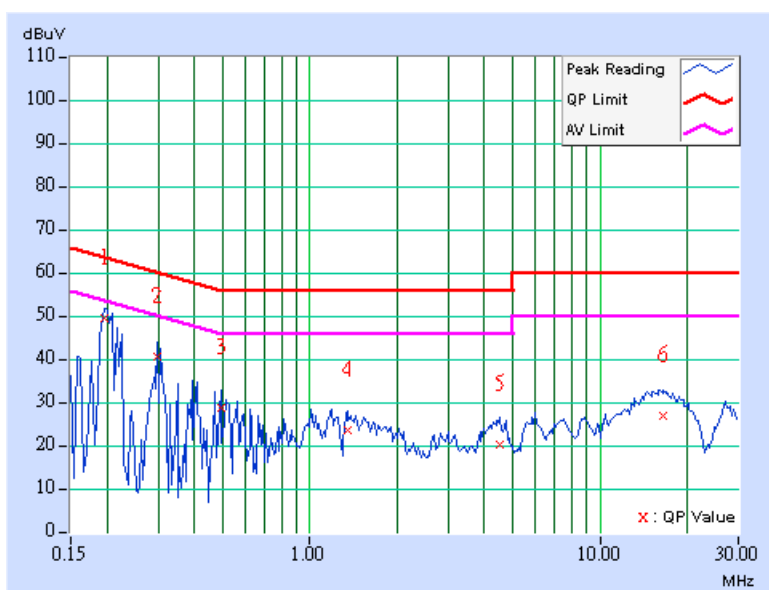

EUT TEST CONDITION		MEASUREMENT DETAIL	
CHANNEL	Channel 11	PHASE	Line 1
MODULATION TYPE	BPSK	6dB BANDWIDTH	9 kHz
TRANSFER RATE	7.2Mbps	INPUT POWER (SYSTEM)	120Vac, 60 Hz
ENVIRONMENTAL CONDITIONS	20deg. C, 60%RH, 991hPa	TESTED BY	Match Tsui

No	Freq. [MHz]	Corr. Factor (dB)	Reading Value [dB (uV)]		Emission Level [dB (uV)]		Limit [dB (uV)]		Margin (dB)	
			Q.P.	AV.	Q.P.	AV.	Q.P.	AV.	Q.P.	AV.
1	0.220	0.10	48.20	-	48.30	-	62.81	52.81	-14.51	-
2	0.310	0.10	39.85	-	39.95	-	59.97	49.97	-20.02	-
3	0.439	0.10	33.58	-	33.68	-	57.08	47.08	-23.40	-
4	1.453	0.15	28.69	-	28.84	-	56.00	46.00	-27.16	-
5	4.469	0.37	21.84	-	22.21	-	56.00	46.00	-33.79	-
6	16.277	0.61	26.62	-	27.23	-	60.00	50.00	-32.77	-

- REMARKS:**
1. Q.P. and AV. are abbreviations of quasi-peak and average individually.
 2. "-": The Quasi-peak reading value also meets average limit and measurement with the average detector is unnecessary.
 3. The emission levels of other frequencies were very low against the limit.
 4. Margin value = Emission level - Limit value
 5. Correction factor = Insertion loss + Cable loss
 6. Emission Level = Correction Factor + Reading Value.

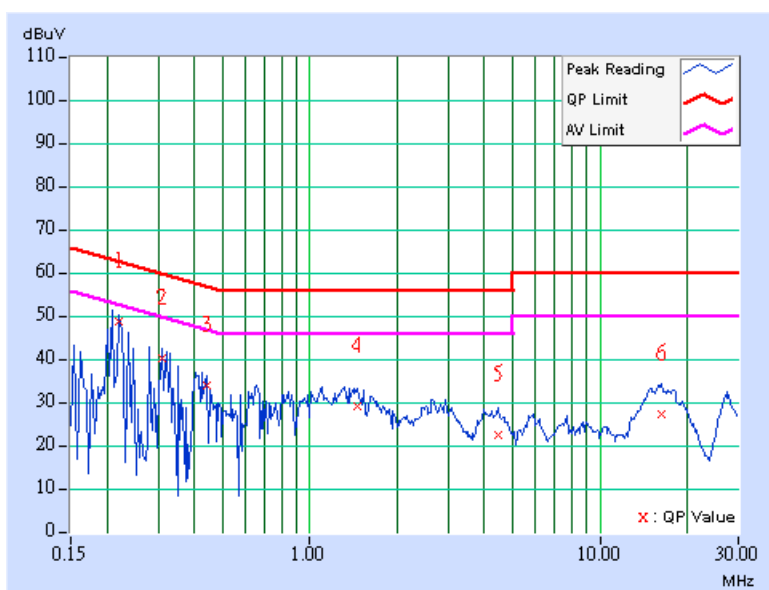

EUT TEST CONDITION		MEASUREMENT DETAIL	
CHANNEL	Channel 11	PHASE	Line 2
MODULATION TYPE	BPSK	6dB BANDWIDTH	9 kHz
TRANSFER RATE	7.2Mbps	INPUT POWER (SYSTEM)	120Vac, 60 Hz
ENVIRONMENTAL CONDITIONS	20deg. C, 60%RH, 991hPa	TESTED BY	Match Tsui

No	Freq. [MHz]	Corr. Factor (dB)	Reading Value [dB (uV)]		Emission Level [dB (uV)]		Limit [dB (uV)]		Margin (dB)	
			Q.P.	AV.	Q.P.	AV.	Q.P.	AV.	Q.P.	AV.
			1	0.207	0.10	47.84	-	47.94	-	63.32
2	0.310	0.10	39.37	-	39.47	-	59.97	49.97	-20.50	-
3	0.509	0.12	29.07	-	29.19	-	56.00	46.00	-26.81	-
4	1.281	0.20	22.00	-	22.20	-	56.00	46.00	-33.80	-
5	4.160	0.37	19.86	-	20.23	-	56.00	46.00	-35.77	-
6	15.996	0.62	26.55	-	27.17	-	60.00	50.00	-32.83	-

- REMARKS:**
1. Q.P. and AV. are abbreviations of quasi-peak and average individually.
 2. "-": The Quasi-peak reading value also meets average limit and measurement with the average detector is unnecessary.
 3. The emission levels of other frequencies were very low against the limit.
 4. Margin value = Emission level - Limit value
 5. Correction factor = Insertion loss + Cable loss
 6. Emission Level = Correction Factor + Reading Value.

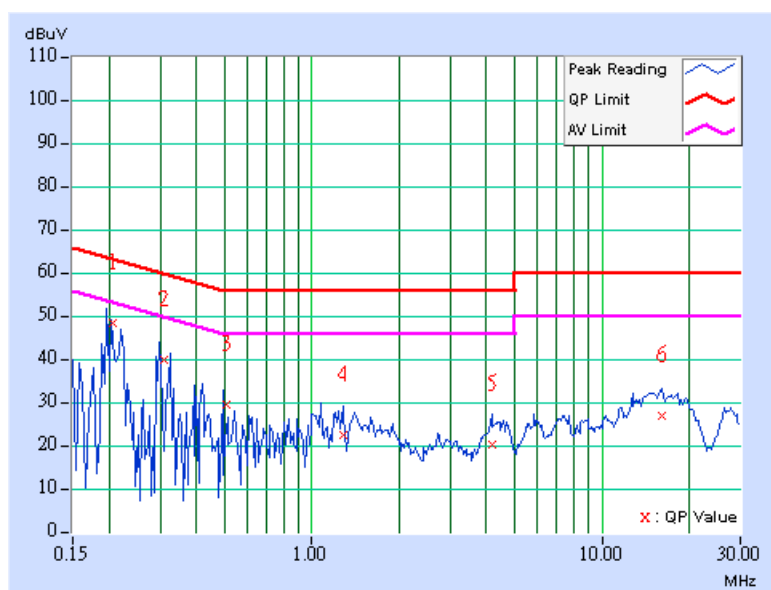

DRAFT 802.11n (40MHz) OFDM MODULATION: DUAL TX

EUT TEST CONDITION		MEASUREMENT DETAIL	
CHANNEL	Channel 1	PHASE	Line 1
MODULATION TYPE	BPSK	6dB BANDWIDTH	9 kHz
TRANSFER RATE	15.0Mbps	INPUT POWER (SYSTEM)	120Vac, 60 Hz
ENVIRONMENTAL CONDITIONS	20deg. C, 60%RH, 991hPa	TESTED BY	Match Tsui

No	Freq. [MHz]	Corr. Factor (dB)	Reading Value [dB (uV)]		Emission Level [dB (uV)]		Limit [dB (uV)]		Margin (dB)	
			Q.P.	AV.	Q.P.	AV.	Q.P.	AV.	Q.P.	AV.
1	0.220	0.10	46.98	-	47.08	-	62.81	52.81	-15.73	-
2	0.334	0.10	37.53	-	37.63	-	59.36	49.36	-21.73	-
3	0.447	0.10	32.54	-	32.64	-	56.93	46.93	-24.29	-
4	1.340	0.13	28.17	-	28.30	-	56.00	46.00	-27.70	-
5	4.285	0.37	21.98	-	22.35	-	56.00	46.00	-33.65	-
6	15.344	0.63	26.61	-	27.24	-	60.00	50.00	-32.76	-

- REMARKS:**
1. Q.P. and AV. are abbreviations of quasi-peak and average individually.
 2. "-": The Quasi-peak reading value also meets average limit and measurement with the average detector is unnecessary.
 3. The emission levels of other frequencies were very low against the limit.
 4. Margin value = Emission level - Limit value
 5. Correction factor = Insertion loss + Cable loss
 6. Emission Level = Correction Factor + Reading Value.

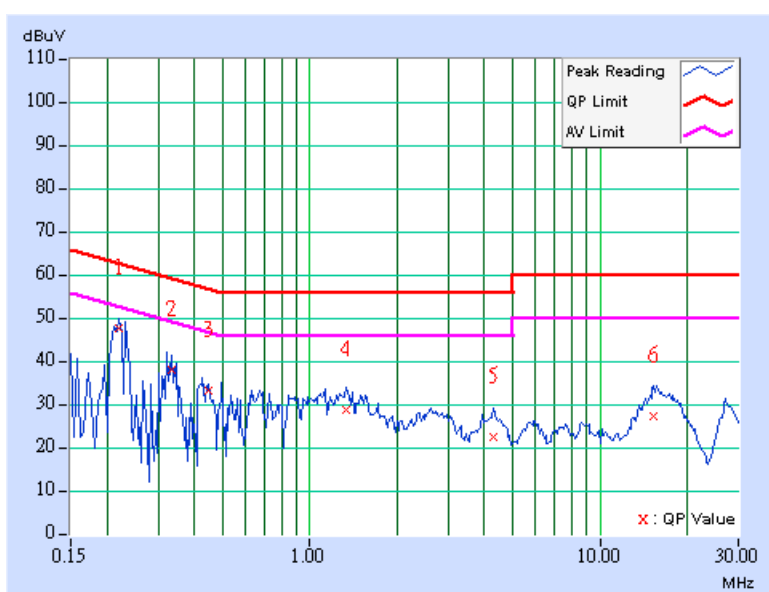

EUT TEST CONDITION		MEASUREMENT DETAIL	
CHANNEL	Channel 1	PHASE	Line 2
MODULATION TYPE	BPSK	6dB BANDWIDTH	9 kHz
TRANSFER RATE	15.0Mbps	INPUT POWER (SYSTEM)	120Vac, 60 Hz
ENVIRONMENTAL CONDITIONS	20deg. C, 60%RH, 991hPa	TESTED BY	Match Tsui

No	Freq. [MHz]	Corr. Factor (dB)	Reading Value [dB (uV)]		Emission Level [dB (uV)]		Limit [dB (uV)]		Margin (dB)	
			Q.P.	AV.	Q.P.	AV.	Q.P.	AV.	Q.P.	AV.
1	0.216	0.10	47.03	-	47.13	-	62.96	52.96	-15.83	-
2	0.326	0.10	38.46	-	38.56	-	59.56	49.56	-21.00	-
3	0.532	0.12	26.72	-	26.84	-	56.00	46.00	-29.16	-
4	1.113	0.20	23.22	-	23.42	-	56.00	46.00	-32.58	-
5	4.305	0.37	19.88	-	20.25	-	56.00	46.00	-35.75	-
6	15.309	0.63	25.82	-	26.45	-	60.00	50.00	-33.55	-

- REMARKS:**
1. Q.P. and AV. are abbreviations of quasi-peak and average individually.
 2. "-": The Quasi-peak reading value also meets average limit and measurement with the average detector is unnecessary.
 3. The emission levels of other frequencies were very low against the limit.
 4. Margin value = Emission level - Limit value
 5. Correction factor = Insertion loss + Cable loss
 6. Emission Level = Correction Factor + Reading Value.

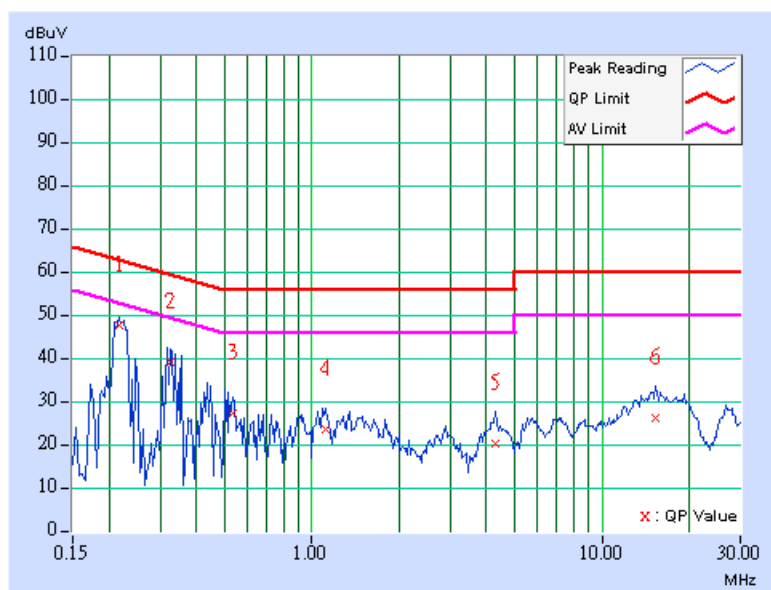

EUT TEST CONDITION		MEASUREMENT DETAIL	
CHANNEL	Channel 4	PHASE	Line 1
MODULATION TYPE	BPSK	6dB BANDWIDTH	9 kHz
TRANSFER RATE	15.0Mbps	INPUT POWER (SYSTEM)	120Vac, 60 Hz
ENVIRONMENTAL CONDITIONS	20deg. C, 60%RH, 991hPa	TESTED BY	Match Tsui

No	Freq. [MHz]	Corr. Factor (dB)	Reading Value [dB (uV)]		Emission Level [dB (uV)]		Limit [dB (uV)]		Margin (dB)	
			Q.P.	AV.	Q.P.	AV.	Q.P.	AV.	Q.P.	AV.
			1	0.228	0.10	46.39	-	46.49	-	62.52
2	0.345	0.10	36.93	-	37.03	-	59.07	49.07	-22.04	-
3	0.466	0.10	32.62	-	32.72	-	56.58	46.58	-23.86	-
4	1.402	0.14	28.22	-	28.36	-	56.00	46.00	-27.64	-
5	4.234	0.37	21.84	-	22.21	-	56.00	46.00	-33.79	-
6	17.098	0.60	26.25	-	26.85	-	60.00	50.00	-33.15	-

- REMARKS:**
1. Q.P. and AV. are abbreviations of quasi-peak and average individually.
 2. "-": The Quasi-peak reading value also meets average limit and measurement with the average detector is unnecessary.
 3. The emission levels of other frequencies were very low against the limit.
 4. Margin value = Emission level - Limit value
 5. Correction factor = Insertion loss + Cable loss
 6. Emission Level = Correction Factor + Reading Value.

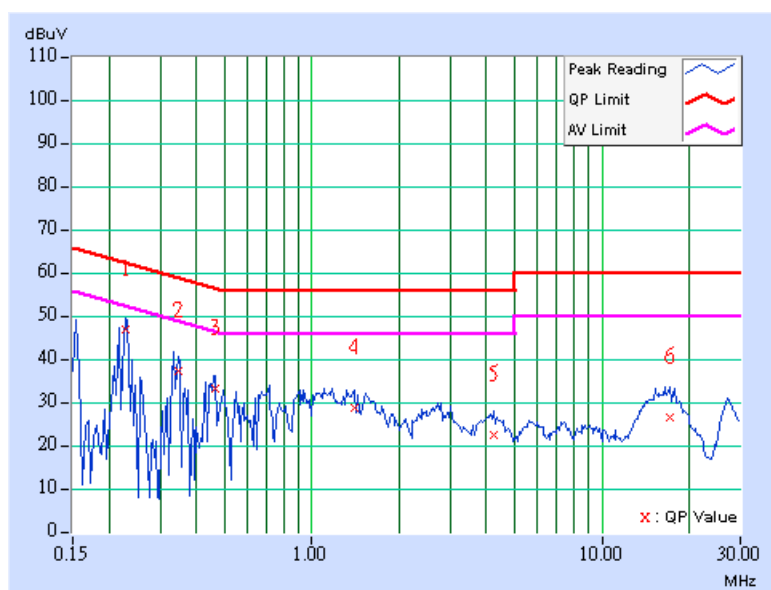

EUT TEST CONDITION		MEASUREMENT DETAIL	
CHANNEL	Channel 4	PHASE	Line 2
MODULATION TYPE	BPSK	6dB BANDWIDTH	9 kHz
TRANSFER RATE	15.0Mbps	INPUT POWER (SYSTEM)	120Vac, 60 Hz
ENVIRONMENTAL CONDITIONS	20deg. C, 65%RH, 991hPa	TESTED BY	Daniel Lin

No	Freq. [MHz]	Corr. Factor (dB)	Reading Value [dB (uV)]		Emission Level [dB (uV)]		Limit [dB (uV)]		Margin (dB)	
			Q.P.	AV.	Q.P.	AV.	Q.P.	AV.	Q.P.	AV.
			1	0.224	0.10	46.07	-	46.17	-	62.67
2	0.326	0.10	39.25	-	39.35	-	59.56	49.56	-20.21	-
3	0.447	0.11	29.12	-	29.23	-	56.93	46.93	-27.71	-
4	1.152	0.20	23.84	-	24.04	-	56.00	46.00	-31.96	-
5	4.148	0.37	19.71	-	20.08	-	56.00	46.00	-35.92	-
6	15.891	0.62	25.73	-	26.35	-	60.00	50.00	-33.65	-

- REMARKS:**
1. Q.P. and AV. are abbreviations of quasi-peak and average individually.
 2. "-": The Quasi-peak reading value also meets average limit and measurement with the average detector is unnecessary.
 3. The emission levels of other frequencies were very low against the limit.
 4. Margin value = Emission level - Limit value
 5. Correction factor = Insertion loss + Cable loss
 6. Emission Level = Correction Factor + Reading Value.

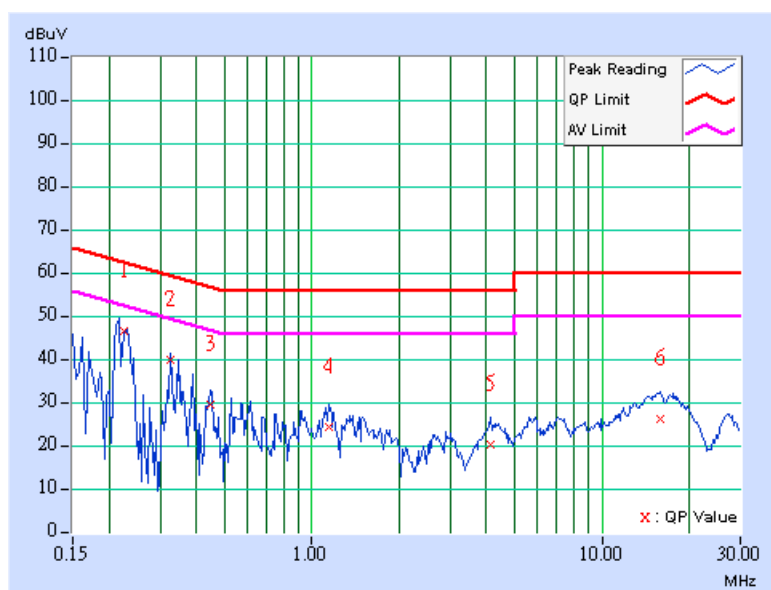

EUT TEST CONDITION		MEASUREMENT DETAIL	
CHANNEL	Channel 7	PHASE	Line 1
MODULATION TYPE	BPSK	6dB BANDWIDTH	9 kHz
TRANSFER RATE	15.0Mbps	INPUT POWER (SYSTEM)	120Vac, 60 Hz
ENVIRONMENTAL CONDITIONS	20deg. C, 60%RH, 991hPa	TESTED BY	Match Tsui

No	Freq. [MHz]	Corr. Factor (dB)	Reading Value [dB (uV)]		Emission Level [dB (uV)]		Limit [dB (uV)]		Margin (dB)	
			Q.P.	AV.	Q.P.	AV.	Q.P.	AV.	Q.P.	AV.
1	0.244	0.10	44.04	-	44.14	-	61.97	51.97	-17.83	-
2	0.358	0.10	37.57	-	37.67	-	58.77	48.77	-21.10	-
3	0.482	0.10	31.71	-	31.81	-	56.30	46.30	-24.49	-
4	1.227	0.12	30.17	-	30.29	-	56.00	46.00	-25.71	-
5	4.164	0.37	21.76	-	22.13	-	56.00	46.00	-33.87	-
6	16.207	0.61	26.48	-	27.09	-	60.00	50.00	-32.91	-

- REMARKS:**
1. Q.P. and AV. are abbreviations of quasi-peak and average individually.
 2. "-": The Quasi-peak reading value also meets average limit and measurement with the average detector is unnecessary.
 3. The emission levels of other frequencies were very low against the limit.
 4. Margin value = Emission level - Limit value
 5. Correction factor = Insertion loss + Cable loss
 6. Emission Level = Correction Factor + Reading Value.

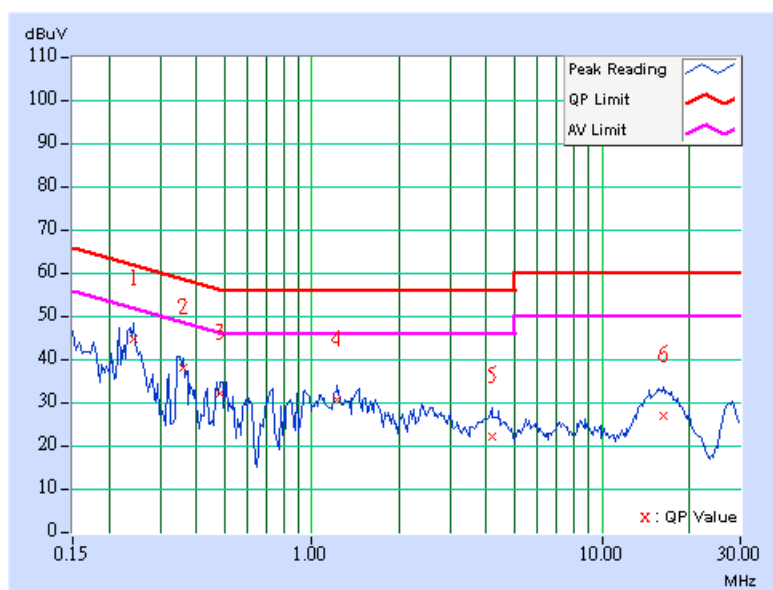

EUT TEST CONDITION		MEASUREMENT DETAIL	
CHANNEL	Channel 7	PHASE	Line 2
MODULATION TYPE	BPSK	6dB BANDWIDTH	9 kHz
TRANSFER RATE	15.0Mbps	INPUT POWER (SYSTEM)	120Vac, 60 Hz
ENVIRONMENTAL CONDITIONS	20deg. C, 60%RH, 991hPa	TESTED BY	Match Tsui

No	Freq. [MHz]	Corr. Factor (dB)	Reading Value [dB (uV)]		Emission Level [dB (uV)]		Limit [dB (uV)]		Margin (dB)	
			Q.P.	AV.	Q.P.	AV.	Q.P.	AV.	Q.P.	AV.
1	0.237	0.10	45.23	-	45.33	-	62.20	52.20	-16.87	-
2	0.365	0.10	35.63	-	35.73	-	58.62	48.62	-22.89	-
3	0.595	0.13	26.57	-	26.70	-	56.00	46.00	-29.30	-
4	1.217	0.20	23.92	-	24.12	-	56.00	46.00	-31.88	-
5	4.160	0.37	18.62	-	18.99	-	56.00	46.00	-37.01	-
6	15.121	0.63	24.98	-	25.61	-	60.00	50.00	-34.39	-

- REMARKS:**
1. Q.P. and AV. are abbreviations of quasi-peak and average individually.
 2. "-": The Quasi-peak reading value also meets average limit and measurement with the average detector is unnecessary.
 3. The emission levels of other frequencies were very low against the limit.
 4. Margin value = Emission level - Limit value
 5. Correction factor = Insertion loss + Cable loss
 6. Emission Level = Correction Factor + Reading Value.

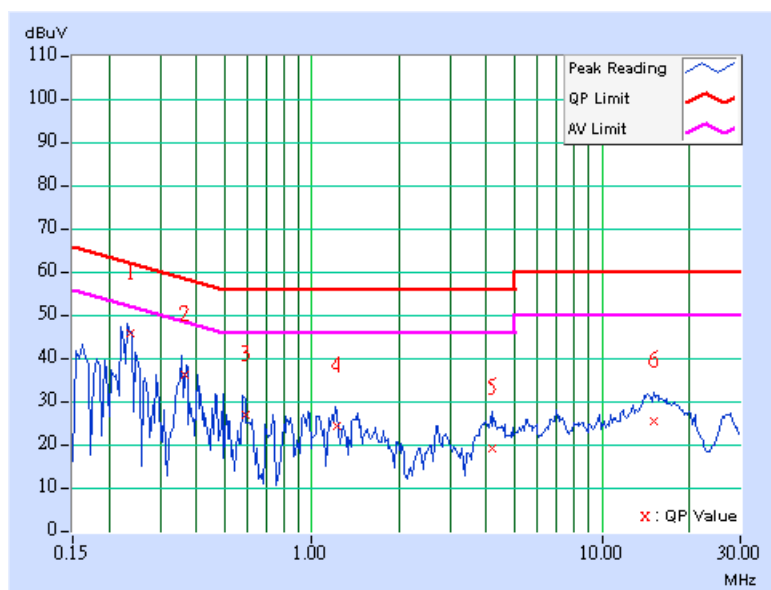

4.2 RADIATED EMISSION MEASUREMENT

4.2.1 LIMITS OF RADIATED EMISSION MEASUREMENT

Emissions radiated outside of the specified bands, shall be according to the general radiated limits in 15.209 as following:

FREQUENCIES (MHz)	FIELD STRENGTH (microvolts/meter)	MEASUREMENT DISTANCE (meters)
0.009 ~ 0.490	2400 / F(kHz)	300
0.490 ~ 1.705	24000 / F(kHz)	30
1.705 ~ 30.0	30	30
30 ~ 88	100	3
88 ~ 216	150	3
216 ~ 960	200	3
Above 960	500	3

NOTE:

1. The lower limit shall apply at the transition frequencies.
2. Emission level (dBuV/m) = 20 log Emission level (uV/m).
3. As shown in 15.35(b), for frequencies above 1000MHz, the field strength limits are based on average detector, however, the peak field strength of any emission shall not exceed the maximum permitted average limits, specified above by more than 20dB under any condition of modulation.



4.2.2 TEST INSTRUMENTS

DESCRIPTION & MANUFACTURER	MODEL NO.	SERIAL NO.	CALIBRATED UNTIL
Test Receiver ROHDE & SCHWARZ	ESMI	839013/007 839379/002	Jan. 24, 2007
Spectrum Analyzer ROHDE & SCHWARZ	FSEK30	100049	Aug. 21, 2007
BILOG Antenna SCHWARZBECK	VULB9168	9168-153	Jan. 15, 2007
HORN Antenna SCHWARZBECK	BBHA 9120 D	9120D-407	Jan. 22, 2007
HORN Antenna SCHWARZBECK	BBHA 9170	BBHA9170242	Jan. 19, 2007
Preamplifier Agilent	8449B	3008A01911	Sep. 13, 2007
RF signal cable HUBER+SUHNNER	SUCOFLEX 104	218188/218189	Dec. 13, 2006
RF signal cable Worken	8D-FB	Cable-HYCH9-01	Mar. 08, 2007
Software ADT.	ADT_Radiated_ V7.6.01	NA	NA
Antenna Tower EMCO	2070/2080	512.835.4684	NA
Antenna Tower Controller EMCO	2090	NA	NA
Turn Table EMCO	2087-2.03	NA	NA
Turn Table Controller EMCO	2090	NA	NA

- NOTE:**
1. The calibration interval of the above test instruments is 12 months and the calibrations are traceable to NML/ROC and NIST/USA.
 2. The test was performed in HwaYa Chamber 9.
 3. The horn antenna and HP preamplifier (model: 8449B) are used only for the measurement of emission frequency above 1GHz if tested.
 4. The IC Site Registration No. is IC4924A-9.

4.2.3 TEST PROCEDURES

- a. The EUT was placed on the top of a rotating table 0.8 meters above the ground at a 3 meters semi-anechoic chamber. The table was rotated 360 degrees to determine the position of the highest radiation.
- b. The EUT was set 3 meters away from the interference-receiving antenna, which was mounted on the top of a variable-height antenna tower.
- c. The antenna is a broadband antenna, and its height is varied from one meter to four meters above the ground to determine the maximum value of the field strength. Both horizontal and vertical polarizations of the antenna are set to make the measurement.
- d. For each suspected emission, the EUT was arranged to its worst case and then the antenna was tuned to heights from 1 meter to 4 meters and the rotatable table was turned from 0 degrees to 360 degrees to find the maximum reading.
- e. The test-receiver system was set to Peak Detect Function and Specified Bandwidth with Maximum Hold Mode.
- f. If the emission level of the EUT in peak mode was lower than the limit specified, then testing could be stopped and the peak values of the EUT would be reported. Otherwise the emissions would be re-tested one by one using peak, quasi-peak or average method as specified and then reported in a data sheet.

NOTE:

1. The resolution bandwidth and video bandwidth of test receiver/spectrum analyzer is 120kHz for Peak detection (PK) and Quasi-peak detection (QP) at frequency below 1GHz.
2. The resolution bandwidth of test receiver/spectrum analyzer is 1 MHz and video bandwidth is 3MHz for Peak detection at frequency above 1GHz.
3. The resolution bandwidth of test receiver/spectrum analyzer is 1MHz and the video bandwidth is 10Hz for Average detection (AV) at frequency above 1GHz.

4.2.4 DEVIATION FROM TEST STANDARD

No deviation

4.2.5 TEST SETUP

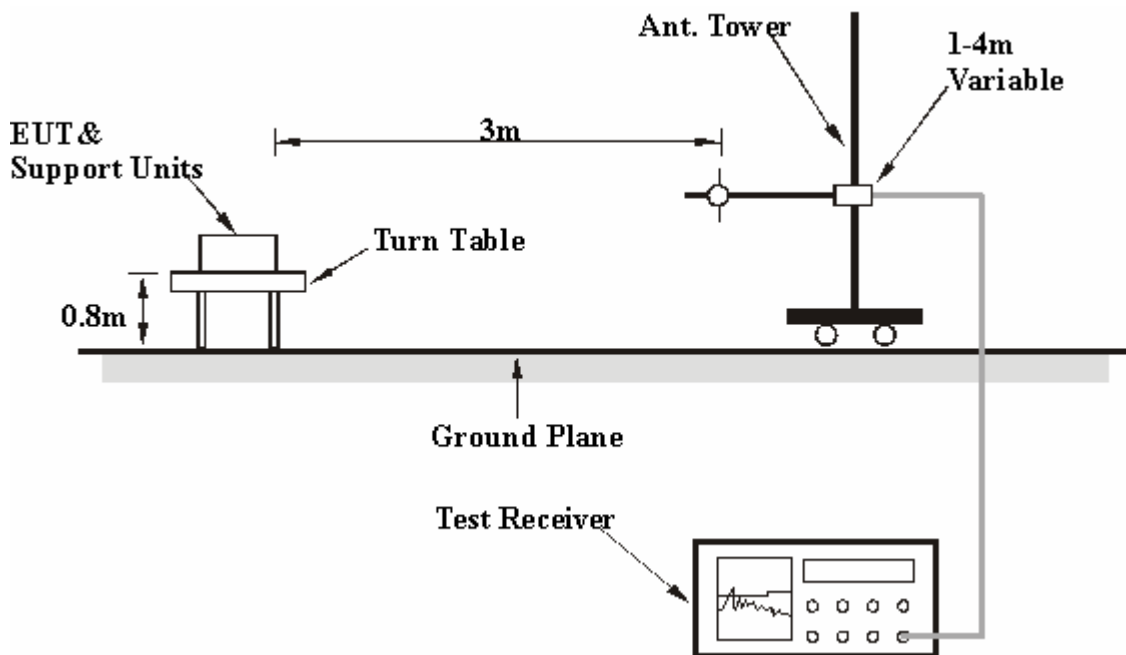

For the actual test configuration, please refer to the attached file (Test Setup Photo).

4.2.6 EUT OPERATING CONDITIONS

Same as 4.1.6

4.2.7 TEST RESULTS

BELOW 1GHz WORST-CASE DATA 802.11g OFDM MODULATION: DUAL TX

EUT TEST CONDITION		MEASUREMENT DETAIL	
CHANNEL	Channel 1	FREQUENCY RANGE	Below 1000MHz
MODULATION TYPE	BPSK for 802.11g	INPUT POWER (SYSTEM)	120Vac, 60 Hz
TRANSFER RATE	6.0Mbps	DETECTOR FUNCTION	Quasi-Peak
ENVIRONMENTAL CONDITIONS	25deg. C, 70%RH, 991hPa	TESTED BY	Lori Chiu

ANTENNA POLARITY & TEST DISTANCE: HORIZONTAL AT 3 M								
No.	Freq. (MHz)	Emission Level (dBuV/m)	Limit (dBuV/m)	Margin (dB)	Antenna Height (m)	Table Angle (Degree)	Raw Value (dBuV)	Correction Factor (dB/m)
1	234.11	35.00 QP	46.00	-11.00	2.00 H	35	23.95	11.05
2	288.54	36.21 QP	46.00	-9.79	1.50 H	24	22.19	14.03
3	300.20	36.25 QP	46.00	-9.75	2.00 H	35	21.73	14.52
4	479.04	42.26 QP	46.00	-3.74	2.00 H	270	24.11	18.15
5	527.64	34.69 QP	46.00	-11.31	1.50 H	99	15.53	19.16
6	753.13	34.05 QP	46.00	-11.95	1.00 H	276	10.13	23.91
7	799.78	39.88 QP	46.00	-6.12	1.00 H	111	15.89	23.98
8	817.27	33.03 QP	46.00	-12.97	1.50 H	99	8.83	24.20
9	902.81	35.91 QP	46.00	-10.09	2.00 H	118	10.85	25.06

ANTENNA POLARITY & TEST DISTANCE: VERTICAL AT 3 M								
No.	Freq. (MHz)	Emission Level (dBuV/m)	Limit (dBuV/m)	Margin (dB)	Antenna Height (m)	Table Angle (Degree)	Raw Value (dBuV)	Correction Factor (dB/m)
1	158.30	27.99 QP	43.50	-15.51	1.00 V	24	15.38	12.61
2	480.98	39.93 QP	46.00	-6.07	1.00 V	24	21.73	18.19
3	527.64	31.18 QP	46.00	-14.82	1.50 V	270	12.03	19.16
4	640.38	30.82 QP	46.00	-15.18	1.50 V	11	9.57	21.25
5	805.61	36.33 QP	46.00	-9.67	1.00 V	24	12.27	24.05
6	902.81	31.88 QP	46.00	-14.12	1.50 V	48	6.82	25.06
7	935.85	31.00 QP	46.00	-15.00	1.00 V	24	4.33	26.67

- REMARKS:**
1. Emission level(dBuV/m)=Raw Value(dBuV) + Correction Factor(dB/m)
 2. Correction Factor(dB/m) = Antenna Factor (dB/m) + Cable Factor (dB)
 3. The other emission levels were very low against the limit.
 4. Margin value = Emission level – Limit value.



DRAFT 802.11n (20MHz) OFDM MODULATION: DUAL TX

EUT TEST CONDITION		MEASUREMENT DETAIL	
CHANNEL	Channel 1	FREQUENCY RANGE	Below 1000MHz
MODULATION TYPE	BPSK for draft 802.11n (20MHz)	INPUT POWER (SYSTEM)	120Vac, 60 Hz
TRANSFER RATE	7.2Mbps	DETECTOR FUNCTION	Quasi-Peak
ENVIRONMENTAL CONDITIONS	25deg. C, 70%RH, 991hPa	TESTED BY	Lori Chiu

ANTENNA POLARITY & TEST DISTANCE: HORIZONTAL AT 3 M								
No.	Freq. (MHz)	Emission Level (dBuV/m)	Limit (dBuV/m)	Margin (dB)	Antenna Height (m)	Table Angle (Degree)	Raw Value (dBuV)	Correction Factor (dB/m)
1	234.11	34.73 QP	46.00	-11.27	1.00 H	92	23.68	11.05
2	288.54	35.72 QP	46.00	-10.28	1.50 H	187	21.69	14.03
3	480.98	38.76 QP	46.00	-7.24	2.00 H	16	20.57	18.19
4	527.64	34.44 QP	46.00	-11.56	1.00 H	17	15.29	19.16
5	803.67	38.50 QP	46.00	-7.50	1.50 H	61	14.47	24.03
6	902.81	35.13 QP	46.00	-10.87	2.00 H	308	10.07	25.06

ANTENNA POLARITY & TEST DISTANCE: VERTICAL AT 3 M								
No.	Freq. (MHz)	Emission Level (dBuV/m)	Limit (dBuV/m)	Margin (dB)	Antenna Height (m)	Table Angle (Degree)	Raw Value (dBuV)	Correction Factor (dB/m)
1	107.76	30.00 QP	43.50	-13.50	1.00 V	29	21.00	9.00
2	480.98	41.64 QP	46.00	-4.36	1.50 V	17	23.45	18.19
3	527.64	31.88 QP	46.00	-14.12	1.50 V	327	12.73	19.16
4	640.38	32.37 QP	46.00	-13.63	2.00 V	352	11.12	21.25
5	677.31	38.53 QP	46.00	-7.47	1.50 V	17	16.60	21.92
6	803.67	42.65 QP	46.00	-3.35	1.50 V	17	18.62	24.03
7	875.59	34.33 QP	46.00	-11.67	1.50 V	17	9.56	24.77
8	885.31	37.19 QP	46.00	-8.81	2.00 V	17	12.35	24.83
9	937.80	31.35 QP	46.00	-14.65	1.50 V	17	4.59	26.76

- REMARKS:**
1. Emission level(dBuV/m)=Raw Value(dBuV) + Correction Factor(dB/m)
 2. Correction Factor(dB/m) = Antenna Factor (dB/m) + Cable Factor (dB)
 3. The other emission levels were very low against the limit.
 4. Margin value = Emission level – Limit value.

DRAFT 802.11n (40MHz) OFDM MODULATION: DUAL TX

EUT TEST CONDITION		MEASUREMENT DETAIL	
CHANNEL	Channel 1	FREQUENCY RANGE	Below 1000MHz
MODULATION TYPE	BPSK for draft 802.11n (40MHz)	INPUT POWER (SYSTEM)	120Vac, 60 Hz
TRANSFER RATE	15.0Mbps	DETECTOR FUNCTION	Quasi-Peak
ENVIRONMENTAL CONDITIONS	25deg. C, 70%RH, 991hPa	TESTED BY	Lori Chiu

ANTENNA POLARITY & TEST DISTANCE: HORIZONTAL AT 3 M								
No.	Freq. (MHz)	Emission Level (dBuV/m)	Limit (dBuV/m)	Margin (dB)	Antenna Height (m)	Table Angle (Degree)	Raw Value (dBuV)	Correction Factor (dB/m)
1	234.11	34.16 QP	46.00	-11.84	1.00 H	35	23.11	11.05
2	288.54	36.13 QP	46.00	-9.87	1.00 H	282	22.11	14.03
3	300.20	35.68 QP	46.00	-10.32	1.00 H	35	21.16	14.52
4	479.04	40.83 QP	46.00	-5.17	1.50 H	206	22.68	18.15
5	527.64	34.25 QP	46.00	-11.75	1.50 H	346	15.10	19.16
6	570.40	33.19 QP	46.00	-12.81	1.00 H	16	13.10	20.09
7	805.61	38.77 QP	46.00	-7.23	1.00 H	149	14.71	24.05

ANTENNA POLARITY & TEST DISTANCE: VERTICAL AT 3 M								
No.	Freq. (MHz)	Emission Level (dBuV/m)	Limit (dBuV/m)	Margin (dB)	Antenna Height (m)	Table Angle (Degree)	Raw Value (dBuV)	Correction Factor (dB/m)
1	158.30	34.54 QP	43.50	-8.96	2.00 V	11	21.93	12.61
2	477.09	43.04 QP	46.00	-2.96	1.00 V	301	24.93	18.11
3	636.49	31.73 QP	46.00	-14.27	1.00 V	358	10.52	21.21
4	797.84	36.79 QP	46.00	-9.21	2.00 V	219	12.81	23.98
5	877.54	34.01 QP	46.00	-11.99	1.00 V	73	9.23	24.78
6	935.85	31.13 QP	46.00	-14.87	1.50 V	187	4.46	26.67

- REMARKS:**
1. Emission level(dBuV/m)=Raw Value(dBuV) + Correction Factor(dB/m)
 2. Correction Factor(dB/m) = Antenna Factor (dB/m) + Cable Factor (dB)
 3. The other emission levels were very low against the limit.
 4. Margin value = Emission level – Limit value.

802.11b DSSS MODULATION: DUAL TX

EUT TEST CONDITION		MEASUREMENT DETAIL	
CHANNEL	Channel 1	FREQUENCY RANGE	1 ~ 25GHz
MODULATION TYPE	DBPSK	INPUT POWER (SYSTEM)	120Vac, 60 Hz
TRANSFER RATE	1.0Mbps	DETECTOR FUNCTION	Peak(PK) Average (AV)
ENVIRONMENTAL CONDITIONS	25deg. C, 70%RH, 991hPa	TESTED BY	Lori Chiu

ANTENNA POLARITY & TEST DISTANCE: HORIZONTAL AT 3 M								
No.	Freq. (MHz)	Emission Level (dBuV/m)	Limit (dBuV/m)	Margin (dB)	Antenna Height (m)	Table Angle (Degree)	Raw Value (dBuV)	Correction Factor (dB/m)
1	2386.00	62.15 PK	74.00	-11.85	1.32 H	282	30.94	31.21
2	2386.00	52.56 AV	54.00	-1.44	1.32 H	282	21.35	31.21
3	*2412.00	113.00 PK			1.35 H	283	81.80	31.20
4	*2412.00	108.42 AV			1.35 H	283	77.22	31.20
5	4824.00	56.15 PK	74.00	-17.85	1.04 H	359	19.72	36.42
6	4824.00	52.83 AV	54.00	-1.17	1.04 H	359	16.40	36.42
7	7236.00	60.78 PK	74.00	-13.22	1.58 H	321	17.86	42.92
8	7236.00	51.80 AV	54.00	-2.20	1.58 H	321	8.88	42.92

ANTENNA POLARITY & TEST DISTANCE: VERTICAL AT 3 M								
No.	Freq. (MHz)	Emission Level (dBuV/m)	Limit (dBuV/m)	Margin (dB)	Antenna Height (m)	Table Angle (Degree)	Raw Value (dBuV)	Correction Factor (dB/m)
1	2386.00	58.58 PK	74.00	-15.42	1.58 V	75	27.37	31.21
2	2386.00	47.33 AV	54.00	-6.67	1.58 V	75	16.12	31.21
3	*2412.00	109.47 PK			1.55 V	76	78.27	31.20
4	*2412.00	105.05 AV			1.55 V	76	73.85	31.20
5	4824.00	51.24 PK	74.00	-22.76	1.23 V	238	14.81	36.42
6	4824.00	46.83 AV	54.00	-7.17	1.23 V	238	10.40	36.42
7	7236.00	57.66 PK	74.00	-16.34	1.44 V	113	14.74	42.92
8	7236.00	46.50 AV	54.00	-7.50	1.44 V	113	3.58	42.92

- REMARKS:**
1. Emission level (dBuV/m) = Raw Value (dBuV) + Correction Factor (dB/m).
 2. Correction Factor (dB/m) = Antenna Factor (dB/m) + Cable Factor (dB).
 3. The other emission levels were very low against the limit.
 4. Margin value = Emission level – Limit value.
 5. The limit value is defined as per 15.247.
 6. “ * “: Fundamental frequency.

EUT TEST CONDITION		MEASUREMENT DETAIL	
CHANNEL	Channel 6	FREQUENCY RANGE	1 ~ 25GHz
MODULATION TYPE	DBPSK	INPUT POWER (SYSTEM)	120Vac, 60 Hz
TRANSFER RATE	1.0Mbps	DETECTOR FUNCTION	Peak(PK) Average (AV)
ENVIRONMENTAL CONDITIONS	25deg. C, 70%RH, 991hPa	TESTED BY	Lori Chiu

ANTENNA POLARITY & TEST DISTANCE: HORIZONTAL AT 3 M								
No.	Freq. (MHz)	Emission Level (dBuV/m)	Limit (dBuV/m)	Margin (dB)	Antenna Height (m)	Table Angle (Degree)	Raw Value (dBuV)	Correction Factor (dB/m)
1	*2437.00	112.29 PK			1.29 H	279	81.08	31.21
2	*2437.00	108.18 AV			1.29 H	279	76.97	31.21
3	4874.00	56.07 PK	74.00	-17.93	1.00 H	360	19.54	36.53
4	4874.00	52.96 AV	54.00	-1.04	1.00 H	360	16.43	36.53
5	7311.00	59.57 PK	74.00	-14.43	1.41 H	111	16.60	42.98
6	7311.00	48.55 AV	54.00	-5.45	1.41 H	111	5.58	42.98
7	9748.00	57.19 PK	74.00	-16.81	1.28 H	256	11.59	45.60
8	9748.00	50.42 AV	54.00	-3.58	1.28 H	256	4.82	45.60

ANTENNA POLARITY & TEST DISTANCE: VERTICAL AT 3 M								
No.	Freq. (MHz)	Emission Level (dBuV/m)	Limit (dBuV/m)	Margin (dB)	Antenna Height (m)	Table Angle (Degree)	Raw Value (dBuV)	Correction Factor (dB/m)
1	*2437.00	109.41 PK			1.32 V	55	78.20	31.21
2	*2437.00	104.97 AV			1.32 V	55	73.76	31.21
3	4874.00	54.28 PK	74.00	-19.72	1.28 V	275	17.75	36.53
4	4874.00	49.71 AV	54.00	-4.29	1.28 V	275	13.18	36.53
5	7311.00	61.58 PK	74.00	-12.42	1.55 V	331	18.61	42.98
6	7311.00	50.85 AV	54.00	-3.15	1.55 V	331	7.88	42.98

- REMARKS:**
1. Emission level (dBuV/m) = Raw Value (dBuV) + Correction Factor (dB/m).
 2. Correction Factor (dB/m) = Antenna Factor (dB/m) + Cable Factor (dB).
 3. The other emission levels were very low against the limit.
 4. Margin value = Emission level – Limit value.
 5. The limit value is defined as per 15.247.
 6. " * ": Fundamental frequency.

EUT TEST CONDITION		MEASUREMENT DETAIL	
CHANNEL	Channel 11	FREQUENCY RANGE	1 ~ 25GHz
MODULATION TYPE	DBPSK	INPUT POWER (SYSTEM)	120Vac, 60 Hz
TRANSFER RATE	1.0Mbps	DETECTOR FUNCTION	Peak(PK) Average (AV)
ENVIRONMENTAL CONDITIONS	25deg. C, 70%RH, 991hPa	TESTED BY	Lori Chiu

ANTENNA POLARITY & TEST DISTANCE: HORIZONTAL AT 3 M								
No.	Freq. (MHz)	Emission Level (dBuV/m)	Limit (dBuV/m)	Margin (dB)	Antenna Height (m)	Table Angle (Degree)	Raw Value (dBuV)	Correction Factor (dB/m)
1	*2462.00	112.04 PK			1.27 H	279	80.82	31.22
2	*2462.00	107.80 AV			1.27 H	279	76.58	31.22
3	2487.00	61.52 PK	74.00	-12.48	1.28 H	281	30.29	31.23
4	2487.00	50.15 AV	54.00	-3.85	1.28 H	281	18.92	31.23
5	4924.00	55.79 PK	74.00	-18.21	1.01 H	1	19.15	36.63
6	4924.00	52.86 AV	54.00	-1.14	1.01 H	1	16.22	36.63
7	7386.00	61.48 PK	74.00	-12.52	1.39 H	316	18.45	43.03
8	7386.00	50.44 AV	54.00	-3.56	1.39 H	316	7.41	43.03

ANTENNA POLARITY & TEST DISTANCE: VERTICAL AT 3 M								
No.	Freq. (MHz)	Emission Level (dBuV/m)	Limit (dBuV/m)	Margin (dB)	Antenna Height (m)	Table Angle (Degree)	Raw Value (dBuV)	Correction Factor (dB/m)
1	*2462.00	109.38 PK			1.51 V	51	78.16	31.22
2	*2462.00	104.81 AV			1.51 V	51	73.59	31.22
3	2487.00	55.43 PK	74.00	-18.57	1.52 V	49	24.20	31.23
4	2487.00	45.43 AV	54.00	-8.57	1.52 V	49	14.20	31.23
5	4924.00	52.34 PK	74.00	-21.66	1.52 V	255	15.71	36.63
6	4924.00	47.75 AV	54.00	-6.25	1.52 V	255	11.12	36.63
7	7386.00	55.66 PK	74.00	-18.34	1.44 V	77	12.63	43.03
8	7386.00	44.23 AV	54.00	-9.77	1.44 V	77	1.20	43.03

- REMARKS:**
1. Emission level (dBuV/m) = Raw Value (dBuV) + Correction Factor (dB/m).
 2. Correction Factor (dB/m) = Antenna Factor (dB/m) + Cable Factor (dB).
 3. The other emission levels were very low against the limit.
 4. Margin value = Emission level – Limit value.
 5. The limit value is defined as per 15.247.
 6. “ * “: Fundamental frequency.

802.11g OFDM MODULATION: DUAL TX

EUT TEST CONDITION		MEASUREMENT DETAIL	
CHANNEL	Channel 1	FREQUENCY RANGE	1 ~ 25GHz
MODULATION TYPE	BPSK	INPUT POWER (SYSTEM)	120Vac, 60 Hz
TRANSFER RATE	6.0Mbps	DETECTOR FUNCTION	Peak(PK) Average (AV)
ENVIRONMENTAL CONDITIONS	25deg. C, 70%RH, 991hPa	TESTED BY	Lori Chiu

ANTENNA POLARITY & TEST DISTANCE: HORIZONTAL AT 3 M								
No.	Freq. (MHz)	Emission Level (dBuV/m)	Limit (dBuV/m)	Margin (dB)	Antenna Height (m)	Table Angle (Degree)	Raw Value (dBuV)	Correction Factor (dB/m)
1	2390.00	72.59 PK	74.00	-1.41	1.34 H	283	41.38	31.21
2	2390.00	52.62 AV	54.00	-1.38	1.34 H	283	21.41	31.21
3	*2412.00	111.46 PK			1.33 H	282	80.26	31.20
4	*2412.00	101.73 AV			1.33 H	282	70.53	31.20
5	4824.00	49.39 PK	74.00	-24.61	1.42 H	14	12.96	36.42
6	4824.00	34.46 AV	54.00	-19.54	1.42 H	14	-1.97	36.42

ANTENNA POLARITY & TEST DISTANCE: VERTICAL AT 3 M								
No.	Freq. (MHz)	Emission Level (dBuV/m)	Limit (dBuV/m)	Margin (dB)	Antenna Height (m)	Table Angle (Degree)	Raw Value (dBuV)	Correction Factor (dB/m)
1	2390.00	70.08 PK	74.00	-3.92	1.63 V	66	38.87	31.21
2	2390.00	47.78 AV	54.00	-6.22	1.63 V	66	16.57	31.21
3	*2412.00	107.89 PK			1.56 V	51	76.69	31.20
4	*2412.00	98.31 AV			1.56 V	51	67.11	31.20
5	4824.00	48.35 PK	74.00	-25.65	1.63 V	283	11.92	36.42
6	4824.00	33.15 AV	54.00	-20.85	1.63 V	283	-3.27	36.42

- REMARKS:**
1. Emission level (dBuV/m) = Raw Value (dBuV) + Correction Factor (dB/m).
 2. Correction Factor (dB/m) = Antenna Factor (dB/m) + Cable Factor (dB).
 3. The other emission levels were very low against the limit.
 4. Margin value = Emission level – Limit value.
 5. The limit value is defined as per 15.247.
 6. “ * “: Fundamental frequency.

EUT TEST CONDITION		MEASUREMENT DETAIL	
CHANNEL	Channel 6	FREQUENCY RANGE	1 ~ 25GHz
MODULATION TYPE	BPSK	INPUT POWER (SYSTEM)	120Vac, 60 Hz
TRANSFER RATE	6.0Mbps	DETECTOR FUNCTION	Peak(PK) Average (AV)
ENVIRONMENTAL CONDITIONS	25deg. C, 70%RH, 991hPa	TESTED BY	Lori Chiu

ANTENNA POLARITY & TEST DISTANCE: HORIZONTAL AT 3 M								
No.	Freq. (MHz)	Emission Level (dBuV/m)	Limit (dBuV/m)	Margin (dB)	Antenna Height (m)	Table Angle (Degree)	Raw Value (dBuV)	Correction Factor (dB/m)
1	2390.00	61.96 PK	74.00	-12.04	1.35 H	279	30.75	31.21
2	2390.00	51.46 AV	54.00	-2.54	1.35 H	279	20.25	31.21
3	*2437.00	113.38 PK			1.31 H	279	82.17	31.21
4	*2437.00	103.49 AV			1.31 H	279	72.28	31.21
5	2483.50	60.54 PK	74.00	-13.46	1.29 H	275	29.31	31.23
6	2483.50	51.09 AV	54.00	-2.91	1.29 H	275	19.86	31.23
7	4874.00	57.01 PK	74.00	-16.99	1.03 H	2	20.48	36.53
8	4874.00	41.89 AV	54.00	-12.11	1.03 H	2	5.36	36.53

ANTENNA POLARITY & TEST DISTANCE: VERTICAL AT 3 M								
No.	Freq. (MHz)	Emission Level (dBuV/m)	Limit (dBuV/m)	Margin (dB)	Antenna Height (m)	Table Angle (Degree)	Raw Value (dBuV)	Correction Factor (dB/m)
1	2390.00	56.68 PK	74.00	-17.32	1.00 V	99	25.47	31.21
2	2390.00	45.87 AV	54.00	-8.13	1.00 V	99	14.66	31.21
3	*2437.00	110.40 PK			1.00 V	97	79.19	31.21
4	*2437.00	100.86 AV			1.00 V	97	69.65	31.21
5	2483.50	56.82 PK	74.00	-17.18	1.00 V	97	25.59	31.23
6	2483.50	45.64 AV	54.00	-8.36	1.00 V	97	14.41	31.23
7	4874.00	56.13 PK	74.00	-17.87	1.05 V	265	19.60	36.53
8	4874.00	41.53 AV	54.00	-12.47	1.05 V	265	5.00	36.53

- REMARKS:**
1. Emission level (dBuV/m) = Raw Value (dBuV) + Correction Factor (dB/m).
 2. Correction Factor (dB/m) = Antenna Factor (dB/m) + Cable Factor (dB).
 3. The other emission levels were very low against the limit.
 4. Margin value = Emission level – Limit value.
 5. The limit value is defined as per 15.247.
 6. “ * “: Fundamental frequency.

EUT TEST CONDITION		MEASUREMENT DETAIL	
CHANNEL	Channel 11	FREQUENCY RANGE	1 ~ 25GHz
MODULATION TYPE	BPSK	INPUT POWER (SYSTEM)	120Vac, 60 Hz
TRANSFER RATE	6.0Mbps	DETECTOR FUNCTION	Peak(PK) Average (AV)
ENVIRONMENTAL CONDITIONS	25deg. C, 70%RH, 991hPa	TESTED BY	Lori Chiu

ANTENNA POLARITY & TEST DISTANCE: HORIZONTAL AT 3 M								
No.	Freq. (MHz)	Emission Level (dBuV/m)	Limit (dBuV/m)	Margin (dB)	Antenna Height (m)	Table Angle (Degree)	Raw Value (dBuV)	Correction Factor (dB/m)
1	*2462.00	110.89 PK			1.29 H	279	79.67	31.22
2	*2462.00	101.08 AV			1.29 H	279	69.86	31.22
3	2483.50	72.67 PK	74.00	-1.33	1.31 H	281	41.44	31.23
4	2483.50	52.72 AV	54.00	-1.28	1.31 H	281	21.49	31.23
5	4924.00	53.33 PK	74.00	-20.67	1.03 H	3	16.69	36.63
6	4924.00	38.10 AV	54.00	-15.90	1.03 H	3	1.46	36.63

ANTENNA POLARITY & TEST DISTANCE: VERTICAL AT 3 M								
No.	Freq. (MHz)	Emission Level (dBuV/m)	Limit (dBuV/m)	Margin (dB)	Antenna Height (m)	Table Angle (Degree)	Raw Value (dBuV)	Correction Factor (dB/m)
1	*2462.00	107.05 PK			1.49 V	67	75.83	31.22
2	*2462.00	97.84 AV			1.49 V	67	66.62	31.22
3	2483.50	70.02 PK	74.00	-3.98	1.50 V	66	38.79	31.23
4	2483.50	47.65 AV	54.00	-6.35	1.50 V	66	16.42	31.23
5	4924.00	52.50 PK	74.00	-21.50	1.18 V	154	15.87	36.63
6	4924.00	37.84 AV	54.00	-16.16	1.18 V	154	1.21	36.63

- REMARKS:**
1. Emission level (dBuV/m) = Raw Value (dBuV) + Correction Factor (dB/m).
 2. Correction Factor (dB/m) = Antenna Factor (dB/m) + Cable Factor (dB).
 3. The other emission levels were very low against the limit.
 4. Margin value = Emission level – Limit value.
 5. The limit value is defined as per 15.247.
 6. “ * “: Fundamental frequency.



DRAFT 802.11n (20MHz) OFDM MODULATION: DUAL TX:

EUT TEST CONDITION		MEASUREMENT DETAIL	
CHANNEL	Channel 1	FREQUENCY RANGE	1 ~ 25GHz
MODULATION TYPE	BPSK	INPUT POWER (SYSTEM)	120Vac, 60 Hz
TRANSFER RATE	7.2Mbps	DETECTOR FUNCTION	Peak(PK) Average (AV)
ENVIRONMENTAL CONDITIONS	25deg. C, 70%RH, 991hPa	TESTED BY	Lori Chiu

ANTENNA POLARITY & TEST DISTANCE: HORIZONTAL AT 3 M								
No.	Freq. (MHz)	Emission Level (dBuV/m)	Limit (dBuV/m)	Margin (dB)	Antenna Height (m)	Table Angle (Degree)	Raw Value (dBuV)	Correction Factor (dB/m)
1	2390.00	72.94 PK	74.00	-1.06	1.35 H	294	41.73	31.21
2	2390.00	52.47 AV	54.00	-1.53	1.35 H	294	21.26	31.21
3	*2412.00	110.42 PK			1.33 H	281	79.22	31.20
4	*2412.00	100.24 AV			1.33 H	281	69.04	31.20
5	4824.00	47.70 PK	74.00	-26.30	1.23 H	212	11.28	36.42
6	4824.00	34.63 AV	54.00	-19.37	1.23 H	212	-1.79	36.42

ANTENNA POLARITY & TEST DISTANCE: VERTICAL AT 3 M								
No.	Freq. (MHz)	Emission Level (dBuV/m)	Limit (dBuV/m)	Margin (dB)	Antenna Height (m)	Table Angle (Degree)	Raw Value (dBuV)	Correction Factor (dB/m)
1	2390.00	68.30 PK	74.00	-5.70	1.25 V	199	37.09	31.21
2	2390.00	48.08 AV	54.00	-5.92	1.25 V	199	16.87	31.21
3	*2412.00	105.98 PK			1.25 V	201	74.78	31.20
4	*2412.00	95.59 AV			1.25 V	201	64.39	31.20
5	4824.00	46.62 PK	74.00	-27.38	1.00 V	87	10.20	36.42
6	4824.00	33.45 AV	54.00	-20.55	1.00 V	87	-2.97	36.42

- REMARKS:**
1. Emission level (dBuV/m) = Raw Value (dBuV) + Correction Factor (dB/m).
 2. Correction Factor (dB/m) = Antenna Factor (dB/m) + Cable Factor (dB).
 3. The other emission levels were very low against the limit.
 4. Margin value = Emission level – Limit value.
 5. The limit value is defined as per 15.247.
 6. “ * “: Fundamental frequency.

EUT TEST CONDITION		MEASUREMENT DETAIL	
CHANNEL	Channel 6	FREQUENCY RANGE	1 ~ 25GHz
MODULATION TYPE	BPSK	INPUT POWER (SYSTEM)	120Vac, 60 Hz
TRANSFER RATE	7.2Mbps	DETECTOR FUNCTION	Peak(PK) Average (AV)
ENVIRONMENTAL CONDITIONS	25deg. C, 70%RH, 991hPa	TESTED BY	Lori Chiu

ANTENNA POLARITY & TEST DISTANCE: HORIZONTAL AT 3 M								
No.	Freq. (MHz)	Emission Level (dBuV/m)	Limit (dBuV/m)	Margin (dB)	Antenna Height (m)	Table Angle (Degree)	Raw Value (dBuV)	Correction Factor (dB/m)
1	2390.00	58.09 PK	74.00	-15.91	1.36 H	281	26.88	31.21
2	2390.00	47.26 AV	54.00	-6.74	1.36 H	281	16.05	31.21
3	*2437.00	111.76 PK			1.32 H	277	80.55	31.21
4	*2437.00	101.75 AV			1.32 H	277	70.54	31.21
5	2483.50	57.95 PK	74.00	-16.05	1.35 H	278	26.72	31.23
6	2483.50	48.07 AV	54.00	-5.93	1.35 H	278	16.84	31.23
7	4874.00	50.59 PK	74.00	-23.41	1.36 H	20	14.06	36.53
8	4874.00	35.95 AV	54.00	-18.05	1.36 H	20	-0.58	36.53

ANTENNA POLARITY & TEST DISTANCE: VERTICAL AT 3 M								
No.	Freq. (MHz)	Emission Level (dBuV/m)	Limit (dBuV/m)	Margin (dB)	Antenna Height (m)	Table Angle (Degree)	Raw Value (dBuV)	Correction Factor (dB/m)
1	*2437.00	106.59 PK			1.32 V	218	75.38	31.21
2	*2437.00	96.84 AV			1.32 V	218	65.63	31.21
3	2483.50	55.75 PK	74.00	-18.25	1.33 V	218	24.52	31.23
4	2483.50	45.52 AV	54.00	-8.48	1.33 V	218	14.29	31.23
5	4874.00	49.82 PK	74.00	-24.18	1.53 V	346	13.29	36.53
6	4874.00	34.16 AV	54.00	-19.84	1.53 V	346	-2.37	36.53

- REMARKS:**
1. Emission level (dBuV/m) = Raw Value (dBuV) + Correction Factor (dB/m).
 2. Correction Factor (dB/m) = Antenna Factor (dB/m) + Cable Factor (dB).
 3. The other emission levels were very low against the limit.
 4. Margin value = Emission level – Limit value.
 5. The limit value is defined as per 15.247.
 6. “ * “: Fundamental frequency.

EUT TEST CONDITION		MEASUREMENT DETAIL	
CHANNEL	Channel 11	FREQUENCY RANGE	1 ~ 25GHz
MODULATION TYPE	BPSK	INPUT POWER (SYSTEM)	120Vac, 60 Hz
TRANSFER RATE	7.2Mbps	DETECTOR FUNCTION	Peak(PK) Average (AV)
ENVIRONMENTAL CONDITIONS	25deg. C, 70%RH, 991hPa	TESTED BY	Lori Chiu

ANTENNA POLARITY & TEST DISTANCE: HORIZONTAL AT 3 M								
No.	Freq. (MHz)	Emission Level (dBuV/m)	Limit (dBuV/m)	Margin (dB)	Antenna Height (m)	Table Angle (Degree)	Raw Value (dBuV)	Correction Factor (dB/m)
1	*2462.00	110.81 PK			1.30 H	279	79.59	31.22
2	*2462.00	100.02 AV			1.30 H	279	68.80	31.22
3	2483.50	72.20 PK	74.00	-1.80	1.28 H	281	40.97	31.23
4	2483.50	52.58 AV	54.00	-1.42	1.28 H	281	21.35	31.23
5	4924.00	49.40 PK	74.00	-24.60	1.16 H	8	12.76	36.63
6	4924.00	34.84 AV	54.00	-19.16	1.16 H	8	-1.80	36.63

ANTENNA POLARITY & TEST DISTANCE: VERTICAL AT 3 M								
No.	Freq. (MHz)	Emission Level (dBuV/m)	Limit (dBuV/m)	Margin (dB)	Antenna Height (m)	Table Angle (Degree)	Raw Value (dBuV)	Correction Factor (dB/m)
1	*2462.00	105.94 PK			1.22 V	210	74.72	31.22
2	*2462.00	95.67 AV			1.22 V	210	64.45	31.22
3	2483.50	68.44 PK	74.00	-5.56	1.23 V	211	37.21	31.23
4	2483.50	47.98 AV	54.00	-6.02	1.23 V	211	16.75	31.23
5	4924.00	46.56 PK	74.00	-27.44	1.39 V	352	9.93	36.63
6	4924.00	33.37 AV	54.00	-20.63	1.39 V	352	-3.26	36.63

- REMARKS:**
1. Emission level (dBuV/m) = Raw Value (dBuV) + Correction Factor (dB/m).
 2. Correction Factor (dB/m) = Antenna Factor (dB/m) + Cable Factor (dB).
 3. The other emission levels were very low against the limit.
 4. Margin value = Emission level – Limit value.
 5. The limit value is defined as per 15.247.
 6. “ * “: Fundamental frequency.



DRAFT 802.11n (40MHz) OFDM MODULATION: DUAL TX:

EUT TEST CONDITION		MEASUREMENT DETAIL	
CHANNEL	Channel 1	FREQUENCY RANGE	1 ~ 25GHz
MODULATION TYPE	BPSK	INPUT POWER (SYSTEM)	120Vac, 60 Hz
TRANSFER RATE	15.0Mbps	DETECTOR FUNCTION	Peak(PK) Average (AV)
ENVIRONMENTAL CONDITIONS	25deg. C, 70%RH, 991hPa	TESTED BY	Lori Chiu

ANTENNA POLARITY & TEST DISTANCE: HORIZONTAL AT 3 M								
No.	Freq. (MHz)	Emission Level (dBuV/m)	Limit (dBuV/m)	Margin (dB)	Antenna Height (m)	Table Angle (Degree)	Raw Value (dBuV)	Correction Factor (dB/m)
1	2390.00	72.96 PK	74.00	-1.04	1.36 H	281	41.75	31.21
2	2390.00	52.73 AV	54.00	-1.27	1.36 H	281	21.52	31.21
3	*2422.00	105.60 PK			1.33 H	283	74.39	31.21
4	*2422.00	95.00 AV			1.33 H	283	63.79	31.21
5	4844.00	45.57 PK	74.00	-28.43	1.32 H	241	9.11	36.46
6	4844.00	32.76 AV	54.00	-21.24	1.32 H	241	-3.70	36.46

ANTENNA POLARITY & TEST DISTANCE: VERTICAL AT 3 M								
No.	Freq. (MHz)	Emission Level (dBuV/m)	Limit (dBuV/m)	Margin (dB)	Antenna Height (m)	Table Angle (Degree)	Raw Value (dBuV)	Correction Factor (dB/m)
1	2390.00	70.71 PK	74.00	-3.29	1.00 V	68	39.50	31.21
2	2390.00	49.57 AV	54.00	-4.43	1.00 V	68	18.36	31.21
3	*2422.00	102.27 PK			1.28 V	97	71.06	31.21
4	*2422.00	92.01 AV			1.28 V	97	60.80	31.21
5	4844.00	44.69 PK	74.00	-29.31	1.00 V	206	8.23	36.46
6	4844.00	31.52 AV	54.00	-22.48	1.00 V	206	-4.94	36.46

- REMARKS:**
1. Emission level (dBuV/m) = Raw Value (dBuV) + Correction Factor (dB/m).
 2. Correction Factor (dB/m) = Antenna Factor (dB/m) + Cable Factor (dB).
 3. The other emission levels were very low against the limit.
 4. Margin value = Emission level – Limit value.
 5. The limit value is defined as per 15.247.
 6. “ * “: Fundamental frequency.

EUT TEST CONDITION		MEASUREMENT DETAIL	
CHANNEL	Channel 4	FREQUENCY RANGE	1 ~ 25GHz
MODULATION TYPE	BPSK	INPUT POWER (SYSTEM)	120Vac, 60 Hz
TRANSFER RATE	15.0Mbps	DETECTOR FUNCTION	Peak(PK) Average (AV)
ENVIRONMENTAL CONDITIONS	25deg. C, 70%RH, 991hPa	TESTED BY	Lori Chiu

ANTENNA POLARITY & TEST DISTANCE: HORIZONTAL AT 3 M								
No.	Freq. (MHz)	Emission Level (dBuV/m)	Limit (dBuV/m)	Margin (dB)	Antenna Height (m)	Table Angle (Degree)	Raw Value (dBuV)	Correction Factor (dB/m)
1	2390.00	68.55 PK	74.00	-5.45	1.31 H	300	37.34	31.21
2	2390.00	51.81 AV	54.00	-2.19	1.31 H	300	20.60	31.21
3	*2437.00	106.88 PK			1.34 H	281	75.67	31.21
4	*2437.00	96.48 AV			1.34 H	281	65.27	31.21
5	2483.50	66.56 PK	74.00	-7.44	1.27 H	279	35.33	31.23
6	2483.50	51.61 AV	54.00	-2.39	1.27 H	279	20.38	31.23
7	4874.00	46.26 PK	74.00	-27.74	1.22 H	205	9.73	36.53
8	4874.00	33.75 AV	54.00	-20.25	1.22 H	205	-2.78	36.53

ANTENNA POLARITY & TEST DISTANCE: VERTICAL AT 3 M								
No.	Freq. (MHz)	Emission Level (dBuV/m)	Limit (dBuV/m)	Margin (dB)	Antenna Height (m)	Table Angle (Degree)	Raw Value (dBuV)	Correction Factor (dB/m)
1	2390.00	55.85 PK	74.00	-18.15	1.32 V	105	24.64	31.21
2	2390.00	45.48 AV	54.00	-8.52	1.32 V	105	14.27	31.21
3	*2437.00	103.58 PK			1.33 V	105	72.37	31.21
4	*2437.00	93.61 AV			1.33 V	105	62.40	31.21
5	2483.50	55.80 PK	74.00	-18.20	1.33 V	106	24.57	31.23
6	2483.50	45.32 AV	54.00	-8.68	1.33 V	106	14.09	31.23
7	4874.00	45.54 PK	74.00	-28.46	1.11 V	232	9.01	36.53
8	4874.00	32.38 AV	54.00	-21.62	1.11 V	232	-4.15	36.53

- REMARKS:**
1. Emission level (dBuV/m) = Raw Value (dBuV) + Correction Factor (dB/m).
 2. Correction Factor (dB/m) = Antenna Factor (dB/m) + Cable Factor (dB).
 3. The other emission levels were very low against the limit.
 4. Margin value = Emission level – Limit value.
 5. The limit value is defined as per 15.247.
 6. “ * “: Fundamental frequency.

EUT TEST CONDITION		MEASUREMENT DETAIL	
CHANNEL	Channel 7	FREQUENCY RANGE	1 ~ 25GHz
MODULATION TYPE	BPSK	INPUT POWER (SYSTEM)	120Vac, 60 Hz
TRANSFER RATE	15.0Mbps	DETECTOR FUNCTION	Peak(PK) Average (AV)
ENVIRONMENTAL CONDITIONS	25deg. C, 70%RH, 991hPa	TESTED BY	Lori Chiu

ANTENNA POLARITY & TEST DISTANCE: HORIZONTAL AT 3 M								
No.	Freq. (MHz)	Emission Level (dBuV/m)	Limit (dBuV/m)	Margin (dB)	Antenna Height (m)	Table Angle (Degree)	Raw Value (dBuV)	Correction Factor (dB/m)
1	*2452.00	105.65 PK			1.30 H	280	74.43	31.22
2	*2452.00	94.87 AV			1.30 H	280	63.65	31.22
3	2483.50	72.33 PK	74.00	-1.67	1.29 H	278	41.10	31.23
4	2483.50	52.92 AV	54.00	-1.08	1.29 H	278	21.69	31.23
5	4904.00	46.03 PK	74.00	-27.97	1.30 H	233	9.44	36.59
6	4904.00	32.41 AV	54.00	-21.59	1.30 H	233	-4.18	36.59

ANTENNA POLARITY & TEST DISTANCE: VERTICAL AT 3 M								
No.	Freq. (MHz)	Emission Level (dBuV/m)	Limit (dBuV/m)	Margin (dB)	Antenna Height (m)	Table Angle (Degree)	Raw Value (dBuV)	Correction Factor (dB/m)
1	*2452.00	102.76 PK			1.00 V	98	71.54	31.22
2	*2452.00	92.71 AV			1.00 V	98	61.49	31.22
3	2483.50	71.75 PK	74.00	-2.25	1.26 V	98	40.52	31.23
4	2483.50	49.83 AV	54.00	-4.17	1.26 V	98	18.60	31.23
5	4904.00	45.27 PK	74.00	-28.73	1.00 V	220	8.68	36.59
6	4904.00	31.84 AV	54.00	-22.16	1.00 V	220	-4.75	36.59

- REMARKS:**
1. Emission level (dBuV/m) = Raw Value (dBuV) + Correction Factor (dB/m).
 2. Correction Factor (dB/m) = Antenna Factor (dB/m) + Cable Factor (dB).
 3. The other emission levels were very low against the limit.
 4. Margin value = Emission level – Limit value.
 5. The limit value is defined as per 15.247.
 6. “ * “: Fundamental frequency.



4.3 6dB BANDWIDTH MEASUREMENT

4.3.1 LIMITS OF 6dB BANDWIDTH MEASUREMENT

The minimum of 6dB Bandwidth Measurement is 0.5 MHz.

4.3.2 TEST INSTRUMENTS

DESCRIPTION & MANUFACTURER	MODEL NO.	SERIAL NO.	CALIBRATED UNTIL
SPECTRUM ANALYZER	FSP40	100040	Jun. 07, 2007

NOTE: The calibration interval of the above test instruments is 12 months and the calibrations are traceable to NML/ROC and NIST/USA.

4.3.3 TEST PROCEDURE

The transmitter output was connected to the spectrum analyzer through an attenuator. The bandwidth of the fundamental frequency was measured by spectrum analyzer with 100kHz RBW and 100kHz VBW. The 6dB bandwidth is defined as the total spectrum the power of which is higher than peak power minus 6dB.

4.3.4 DEVIATION FROM TEST STANDARD

No deviation

4.3.5 TEST SETUP

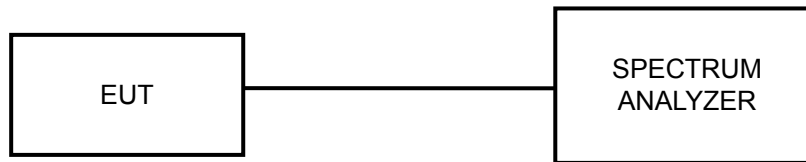

4.3.6 EUT OPERATING CONDITIONS

The software provided by client to enable the EUT under transmission condition continuously at lowest, middle and highest channel frequencies individually.

4.3.7 TEST RESULTS

802.11b DSSS MODULATION: DUAL TX

MODULATION TYPE	DBPSK	TRANSFER RATE	1.0Mbps
INPUT POWER (SYSTEM)	120Vac, 60 Hz	ENVIRONMENTAL CONDITIONS	25deg.C, 63%RH, 991hPa
TESTED BY	Long Chen		

CHANNEL	CHANNEL FREQUENCY (MHz)	6dB BANDWIDTH (MHz)		MINIMUM LIMIT (MHz)	PASS / FAIL
		CHAIN 0	CHAIN 1		
1	2412	12.04	12.04	0.5	PASS
6	2437	12.00	12.00	0.5	PASS
11	2462	12.00	12.08	0.5	PASS

FOR CHAIN 0: CH 1

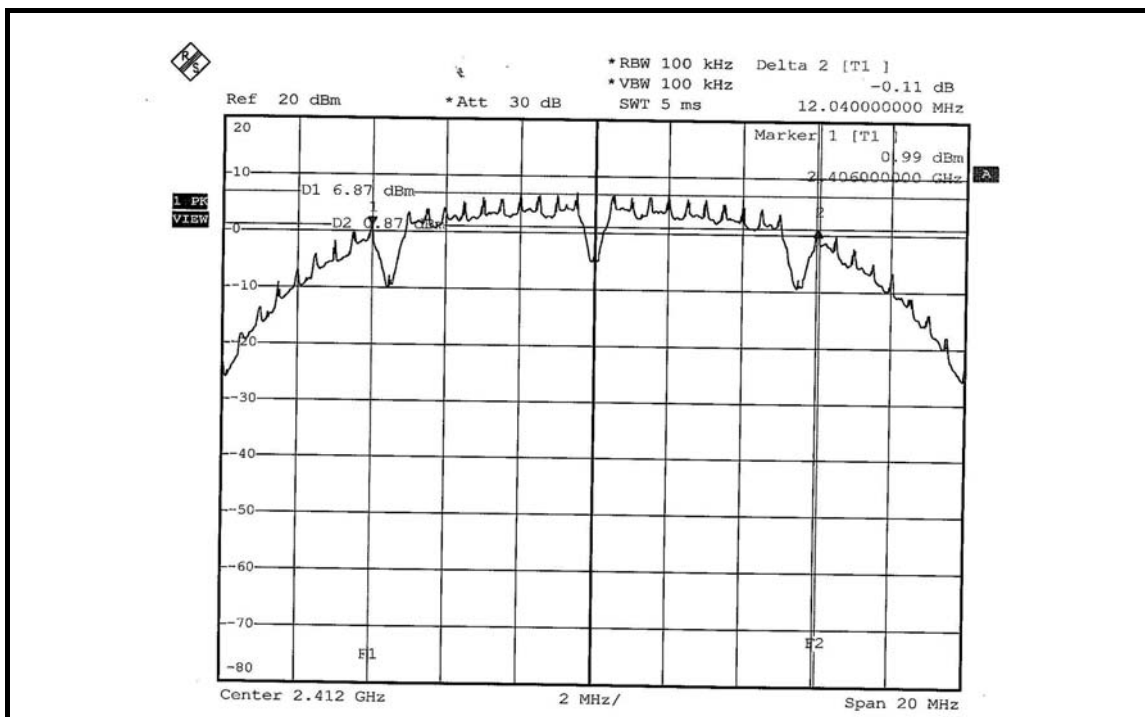

CH 6

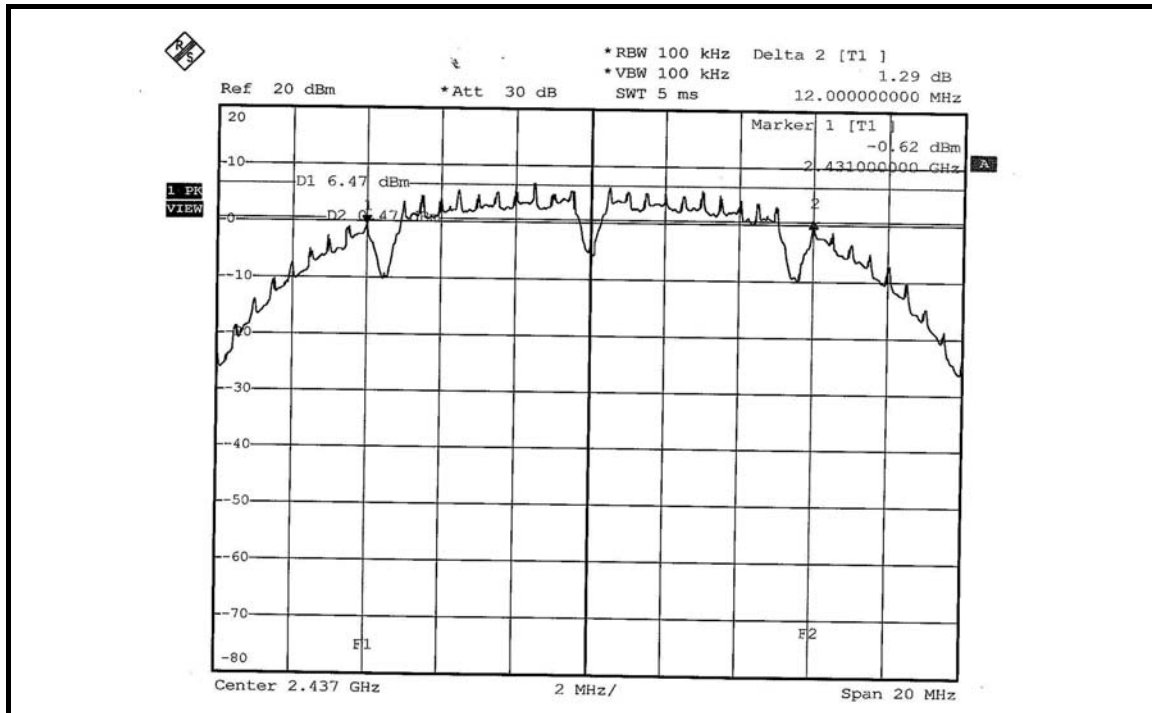

CH 11

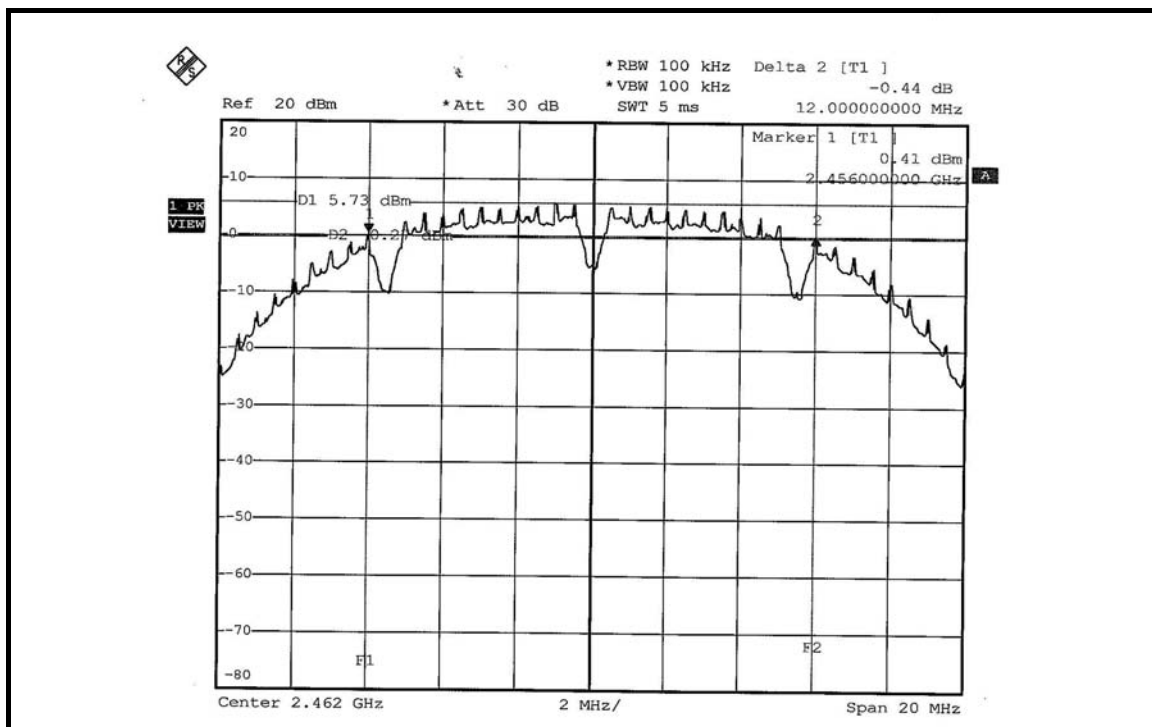

FOR CHAIN 1: CH 1

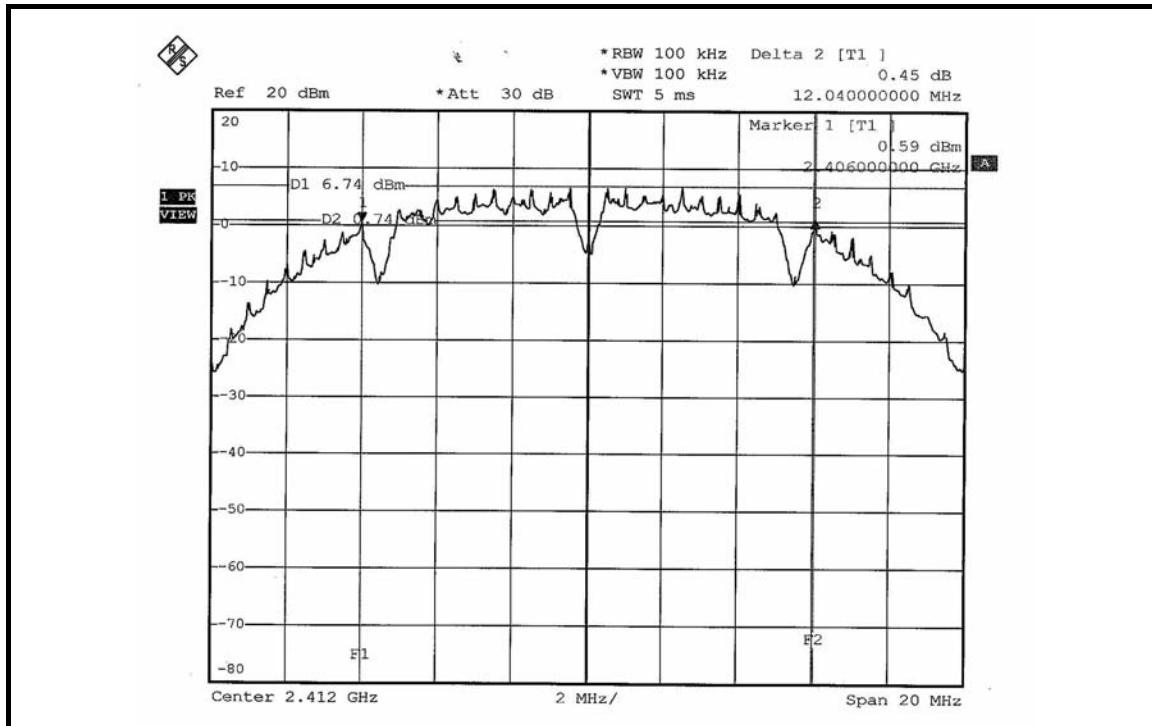

CH 6

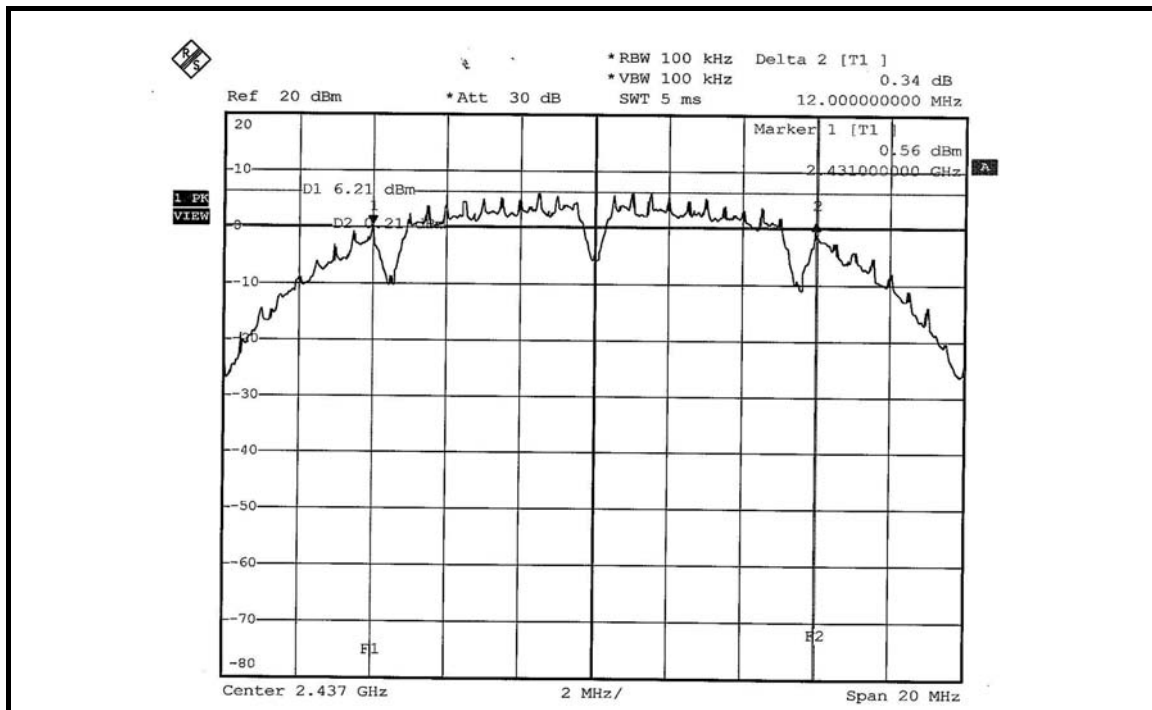

CH 11

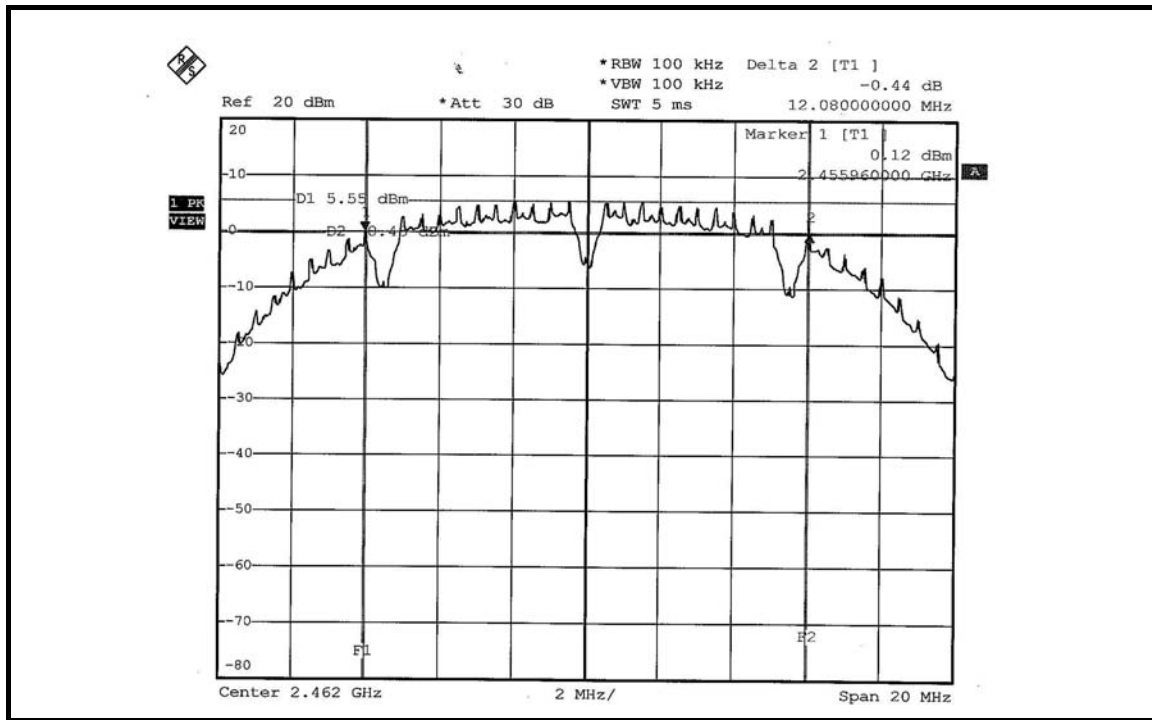

802.11g OFDM MODULATION: DUAL TX

MODULATION TYPE	BPSK	TRANSFER RATE	6.0Mbps
INPUT POWER (SYSTEM)	120Vac, 60 Hz	ENVIRONMENTAL CONDITIONS	25deg.C, 63%RH, 991hPa
TESTED BY	Long Chen		

CHANNEL	CHANNEL FREQUENCY (MHz)	6dB BANDWIDTH (MHz)		MINIMUM LIMIT (MHz)	PASS / FAIL
		CHAIN 0	CHAIN 1		
1	2412	16.40	16.44	0.5	PASS
6	2437	16.40	16.40	0.5	PASS
11	2462	16.32	16.40	0.5	PASS

FOR CHAIN 0: CH 1

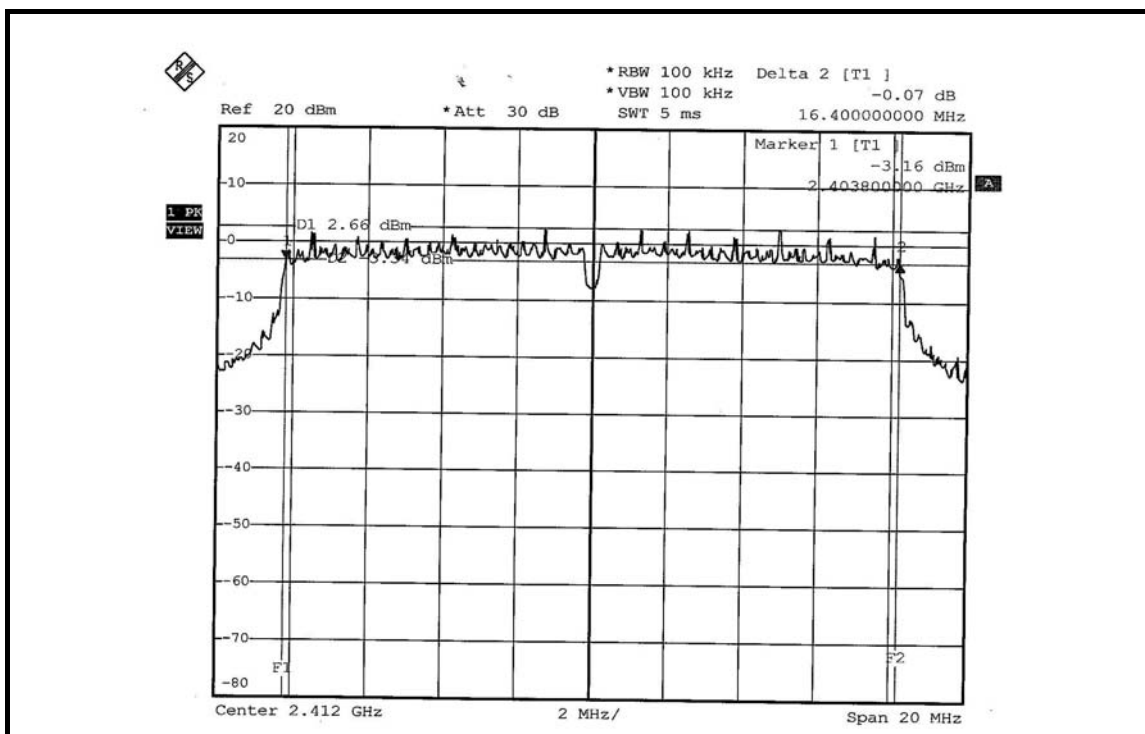

CH 6

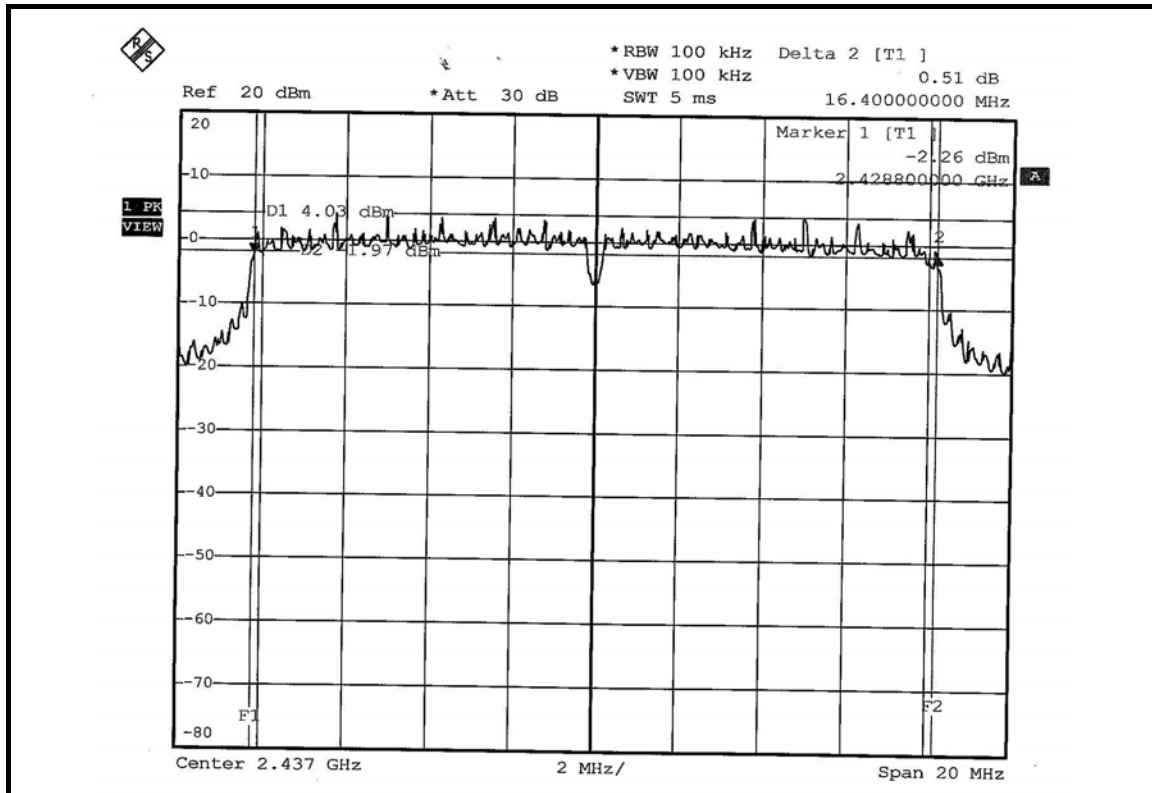

CH 11

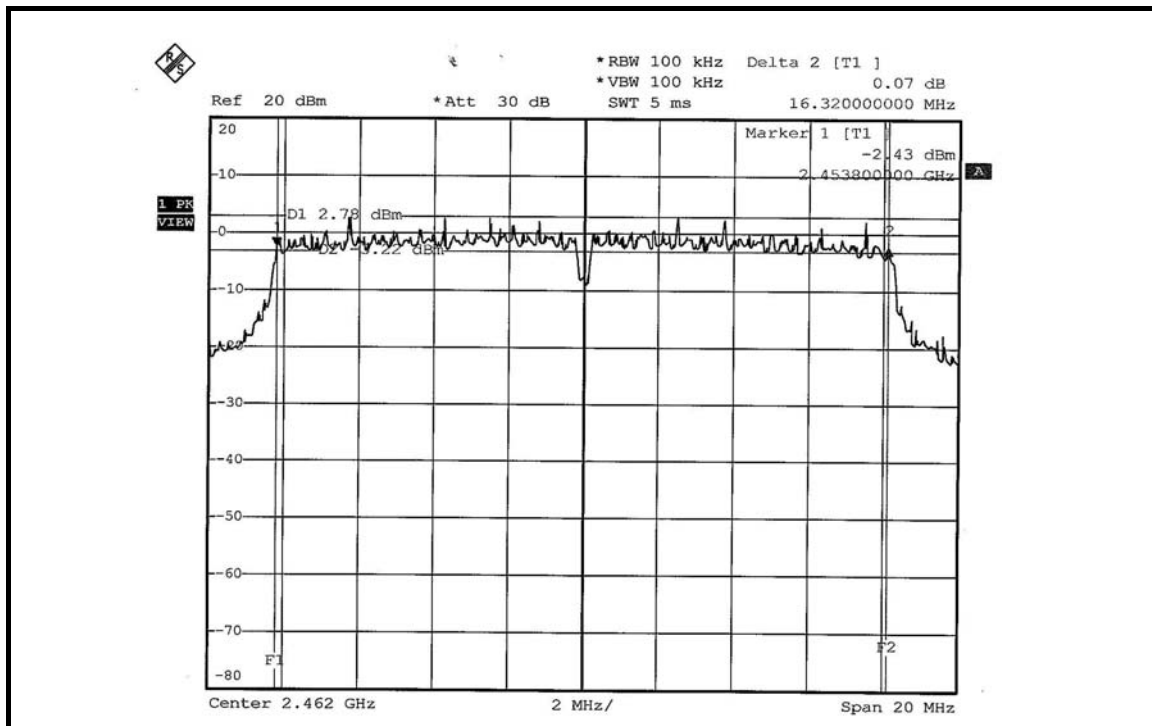

FOR CHAIN 1: CH 1

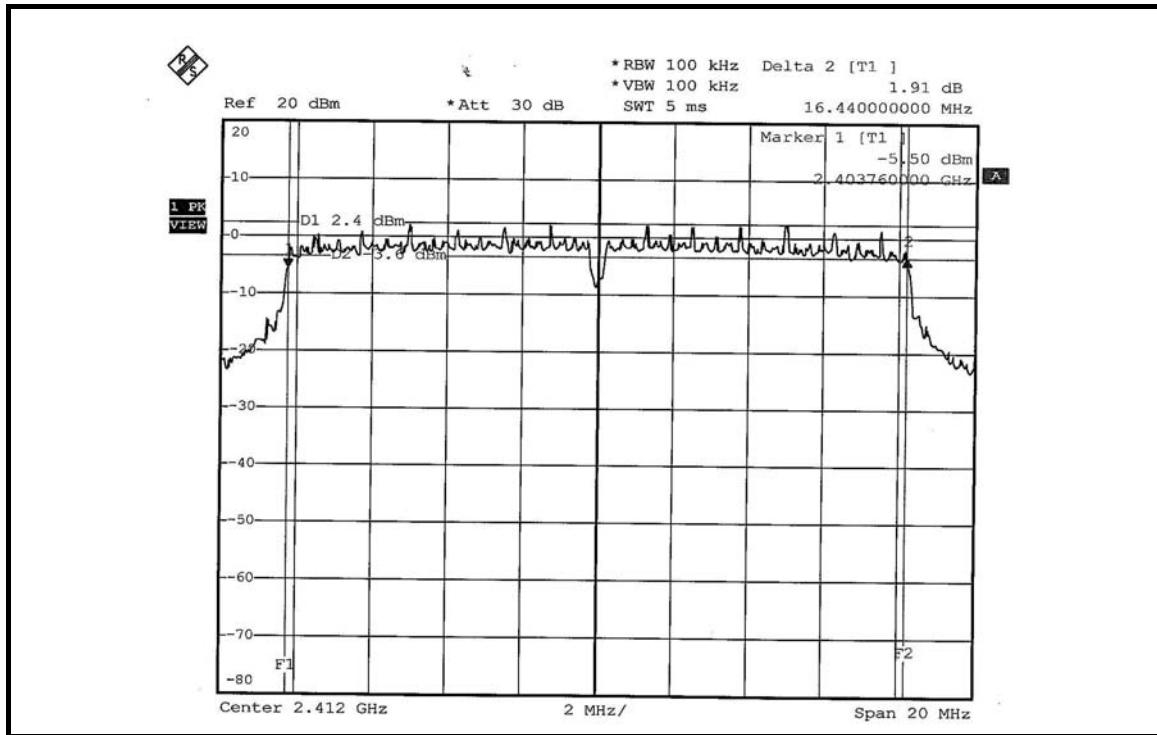

CH 6

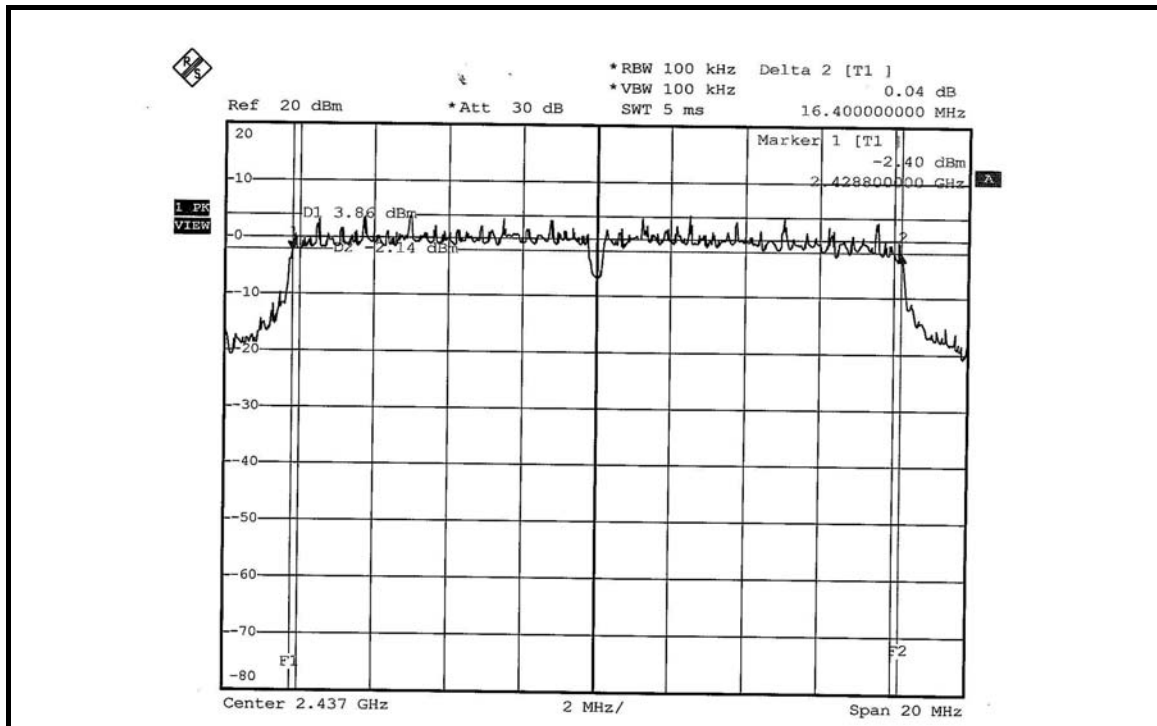

CH 11

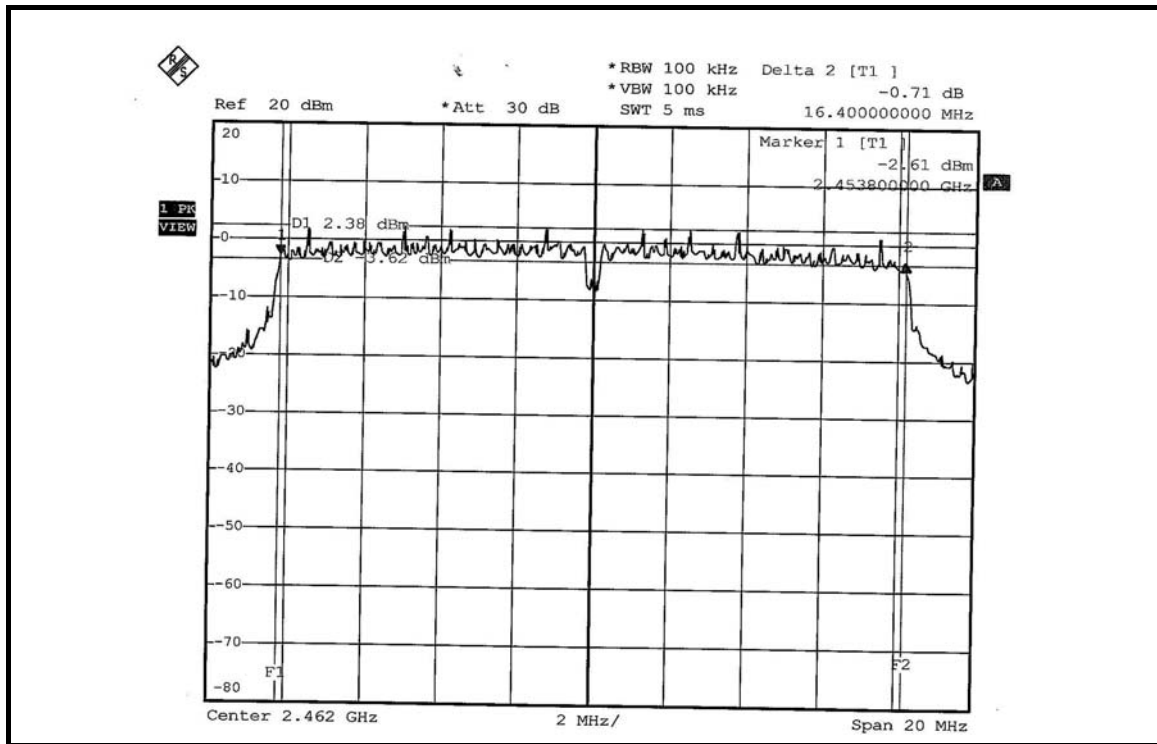



DRAFT 802.11n (20MHz) OFDM MODULATION: DUAL TX:

MODULATION TYPE	BPSK	TRANSFER RATE	7.2Mbps
INPUT POWER (SYSTEM)	120Vac, 60 Hz	ENVIRONMENTAL CONDITIONS	25deg.C, 63%RH, 991hPa
TESTED BY	Long Chen		

CHANNEL	CHANNEL FREQUENCY (MHz)	6dB BANDWIDTH (MHz)		MINIMUM LIMIT (MHz)	PASS / FAIL
		CHAIN 0	CHAIN 1		
1	2412	17.56	17.64	0.5	PASS
6	2437	17.56	17.60	0.5	PASS
11	2462	17.56	17.60	0.5	PASS

FOR CHAIN 0: CH 1

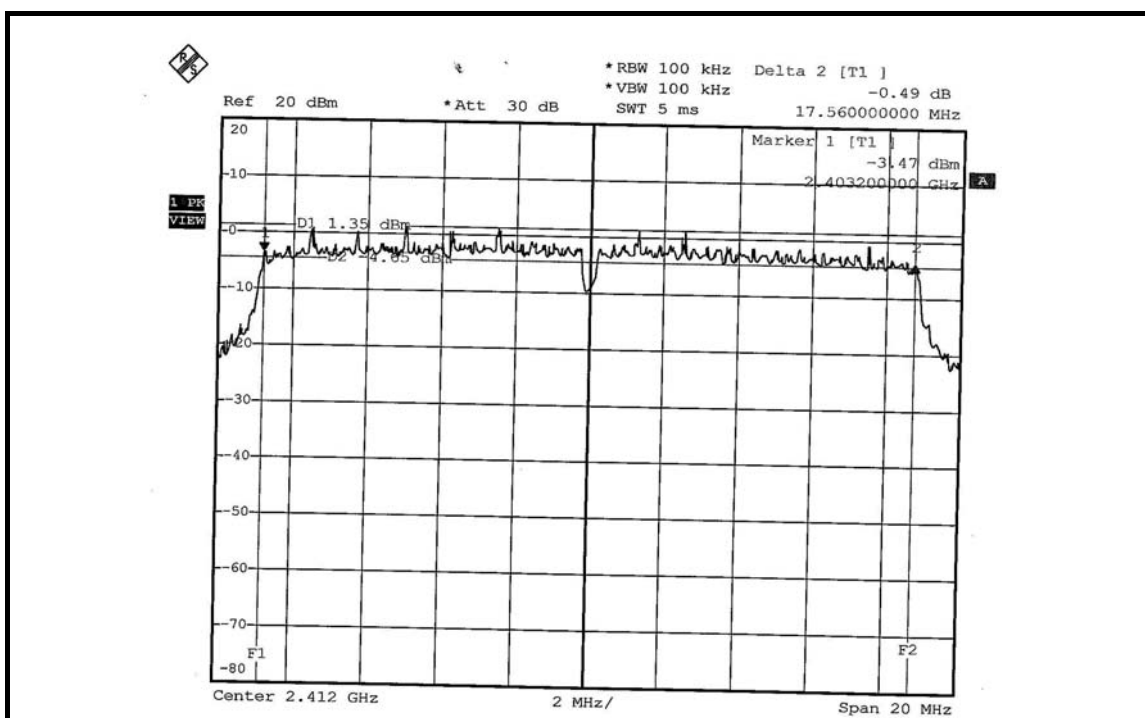

CH 6

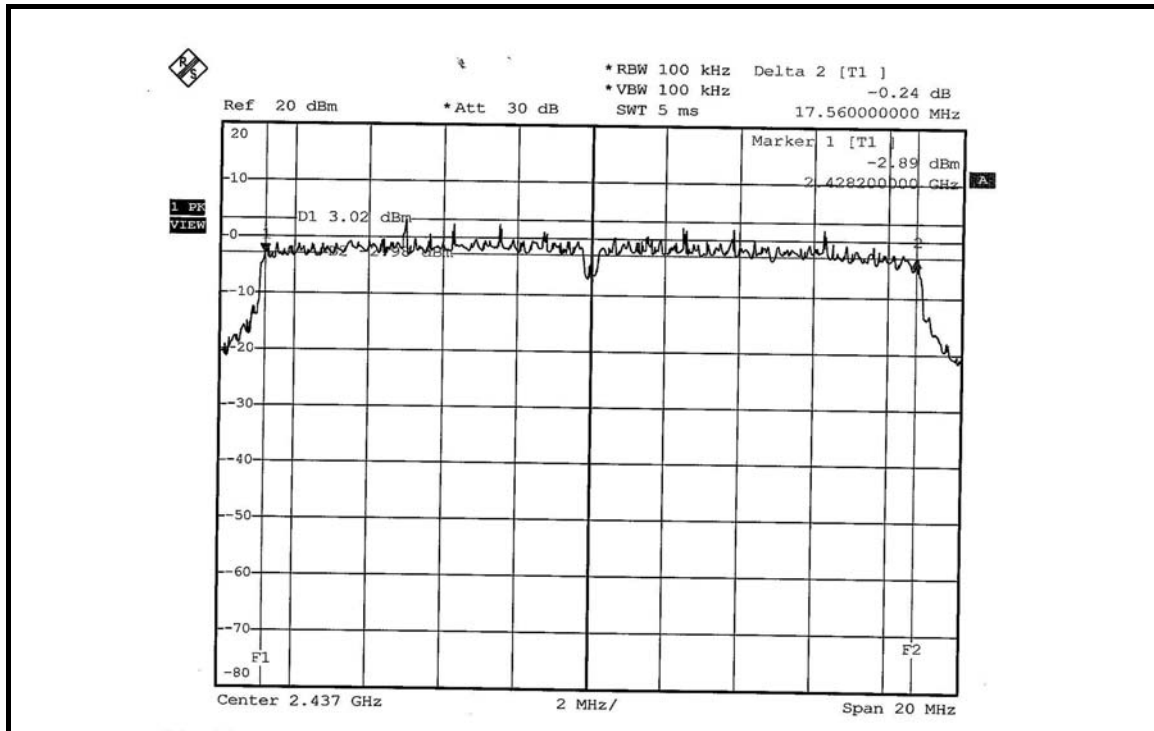

CH 11

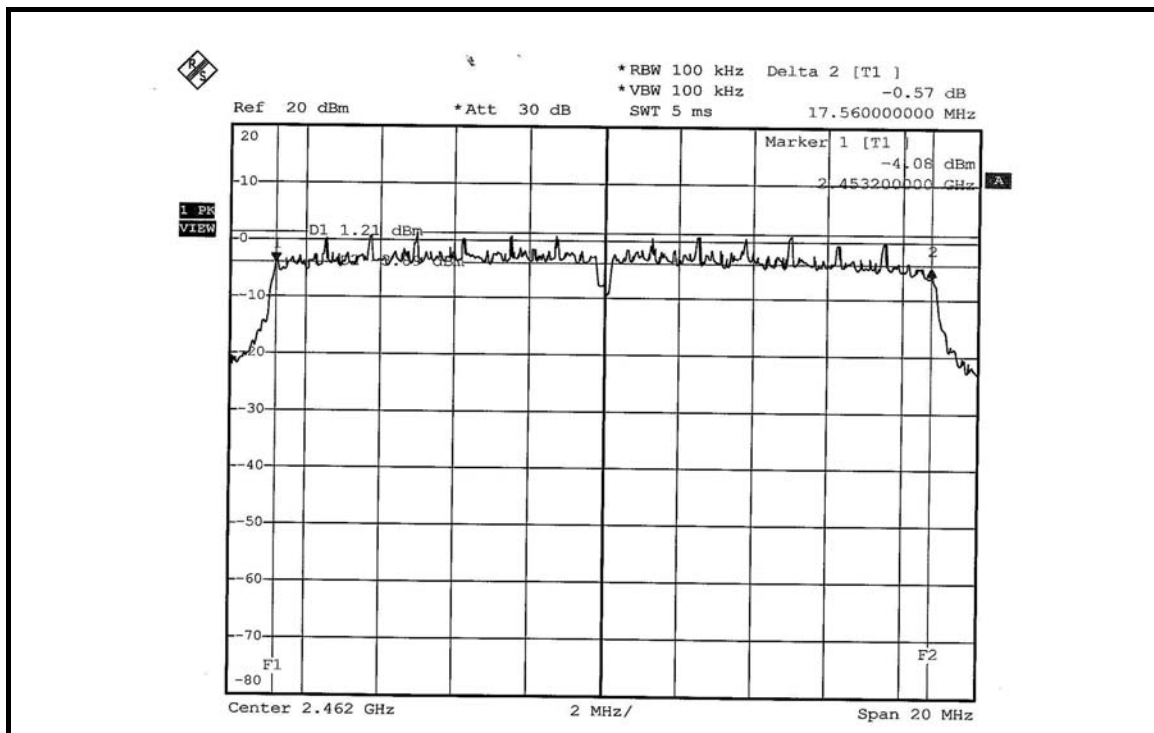

FOR CHAIN 1: CH 1

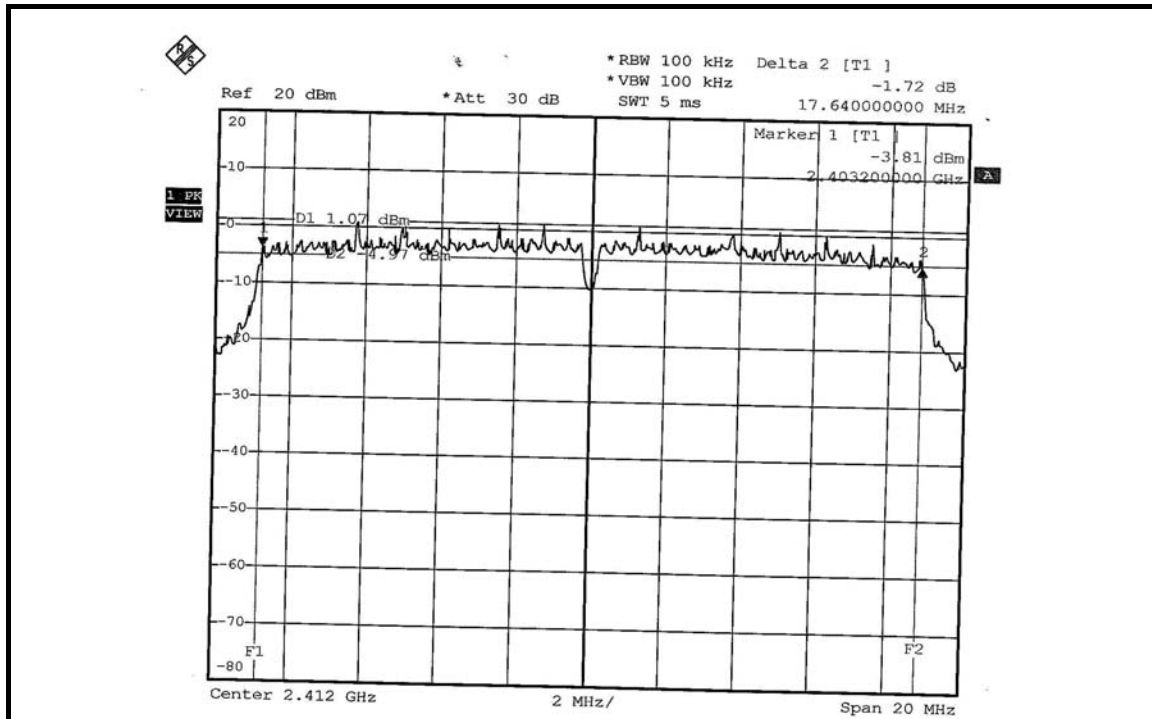

CH 6

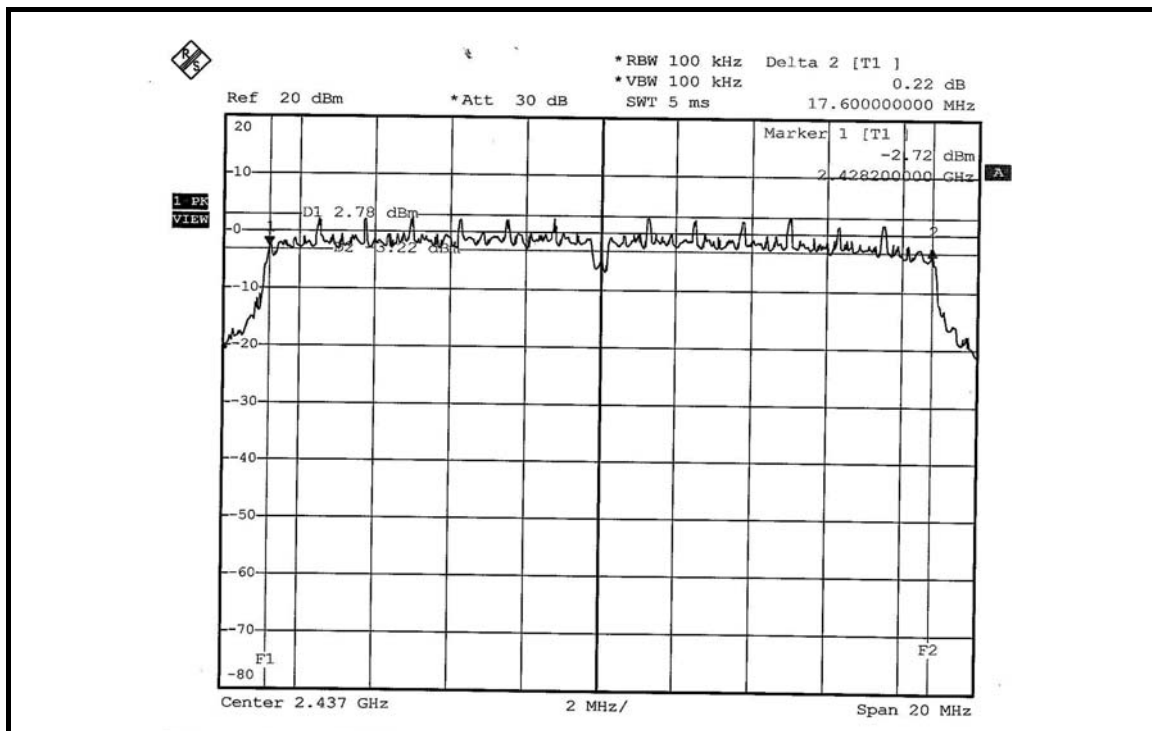

CH 11

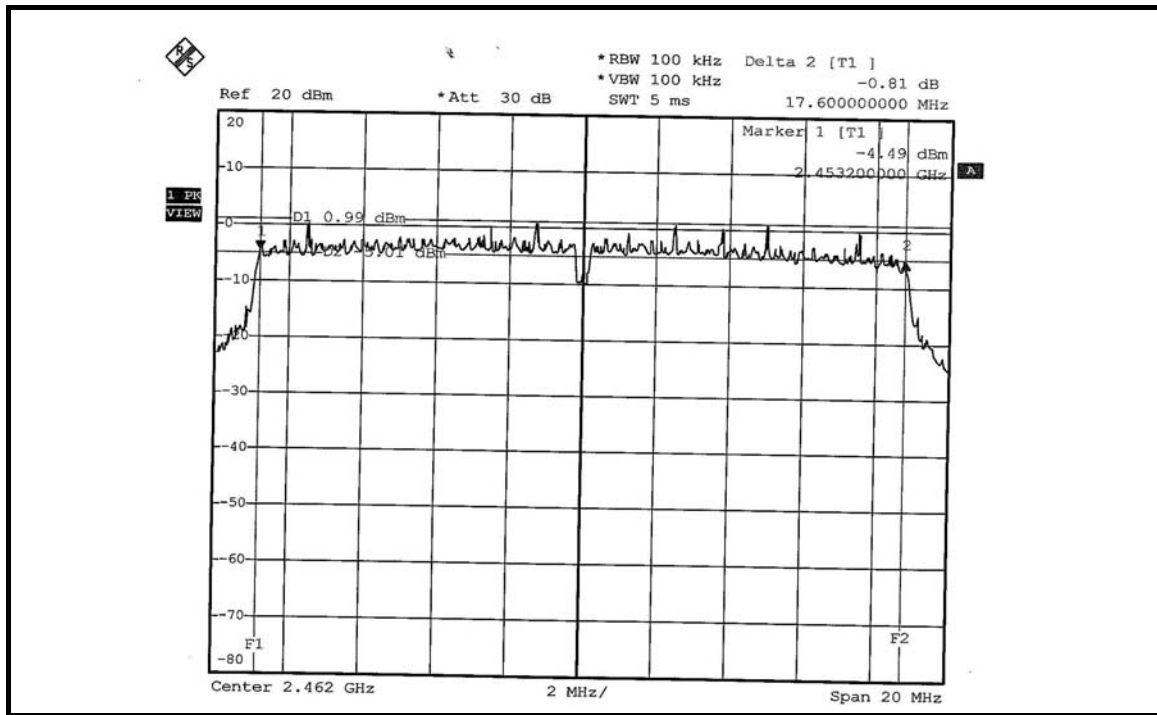

DRAFT 802.11n (40MHz) OFDM MODULATION: DUAL TX:

MODULATION TYPE	BPSK	TRANSFER RATE	15.0Mbps
INPUT POWER (SYSTEM)	120Vac, 60 Hz	ENVIRONMENTAL CONDITIONS	25deg.C, 63%RH, 991hPa
TESTED BY	Long Chen		

CHANNEL	CHANNEL FREQUENCY (MHz)	6dB BANDWIDTH (MHz)		MINIMUM LIMIT (MHz)	PASS / FAIL
		CHAIN 0	CHAIN 1		
1	2422	36.48	36.48	0.5	PASS
4	2437	36.48	36.40	0.5	PASS
7	2452	36.48	36.48	0.5	PASS

FOR CHAIN 0: CH 1

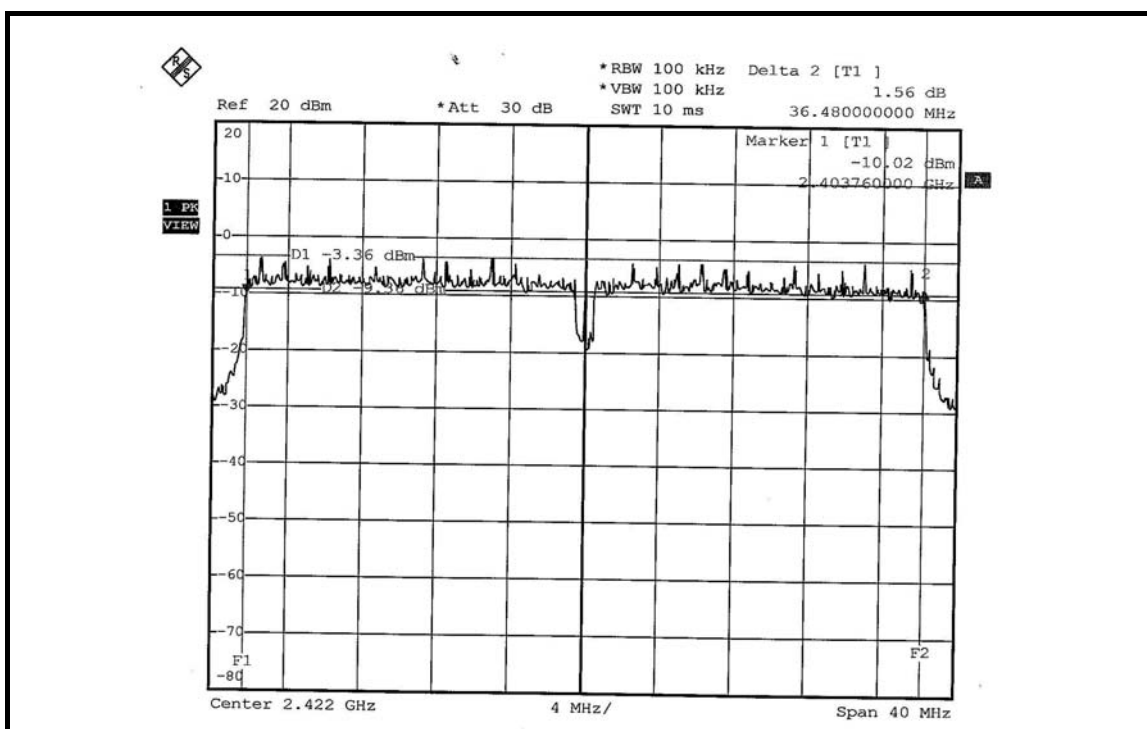

CH 4

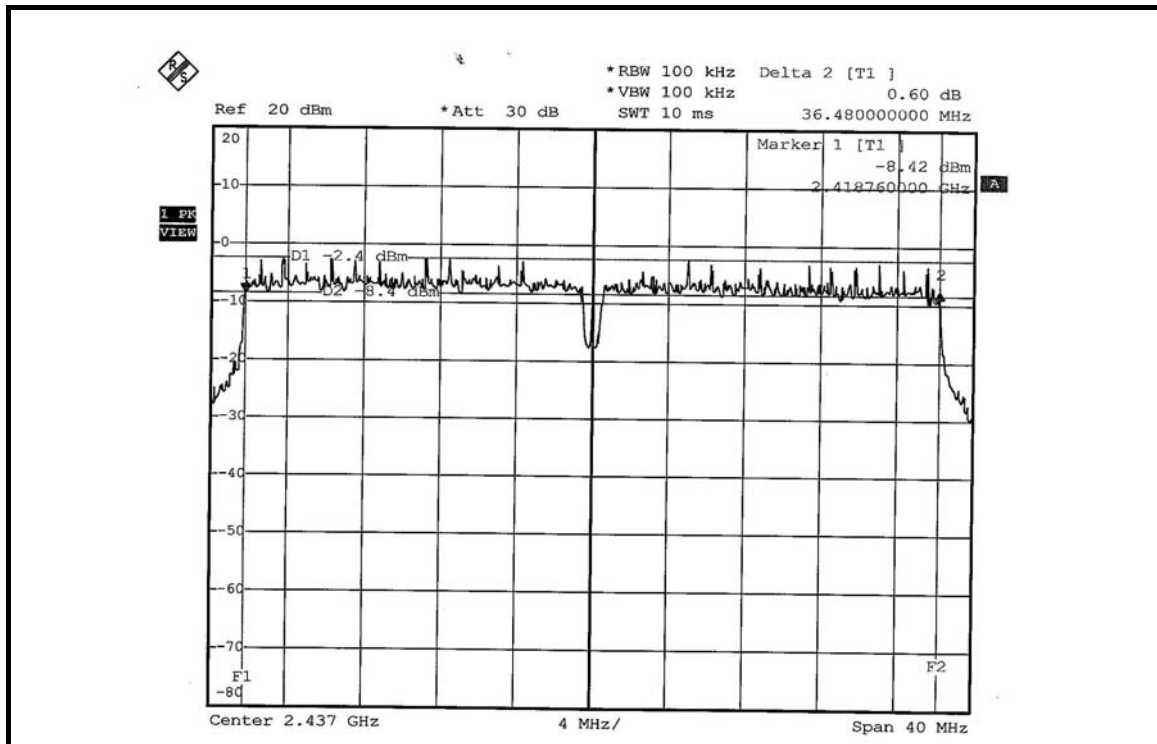

CH 7

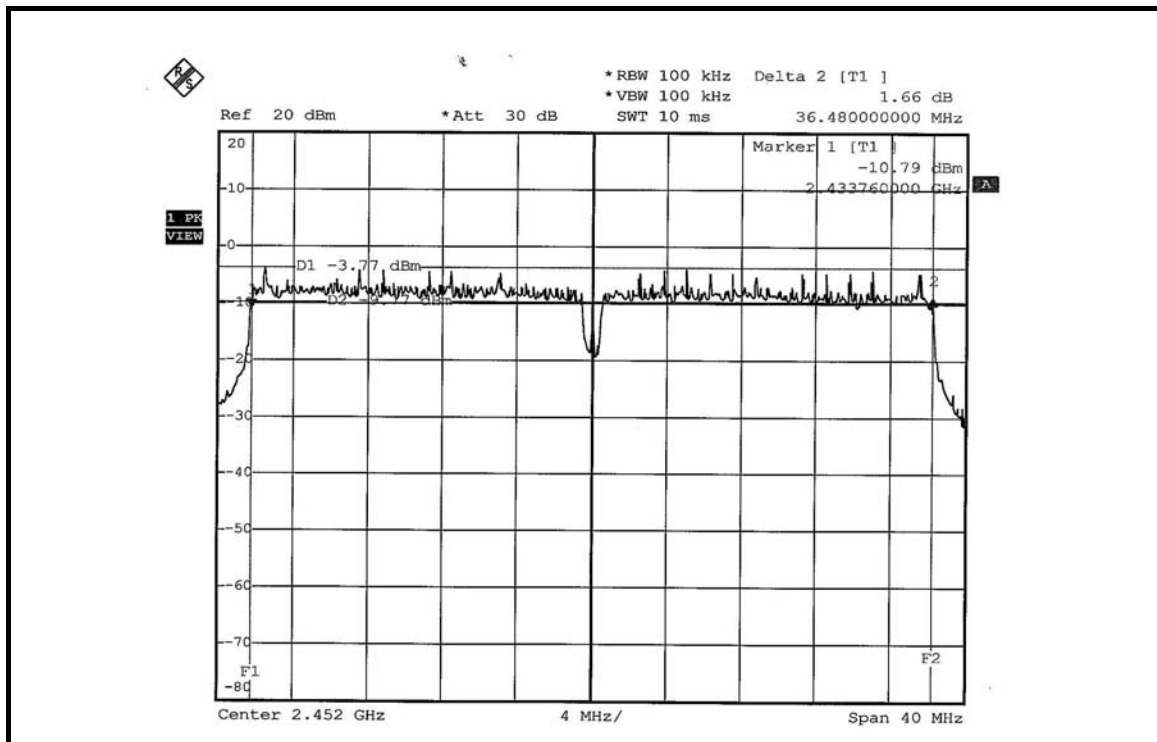

FOR CHAIN 1: CH 1

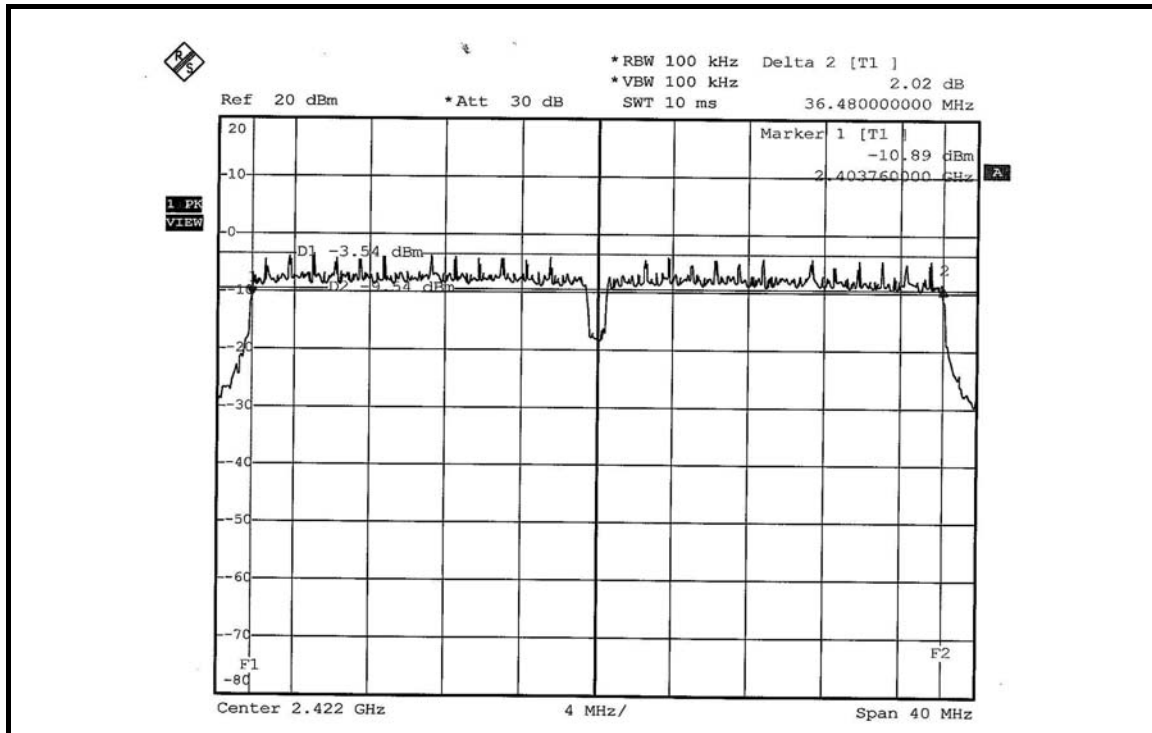

CH 4

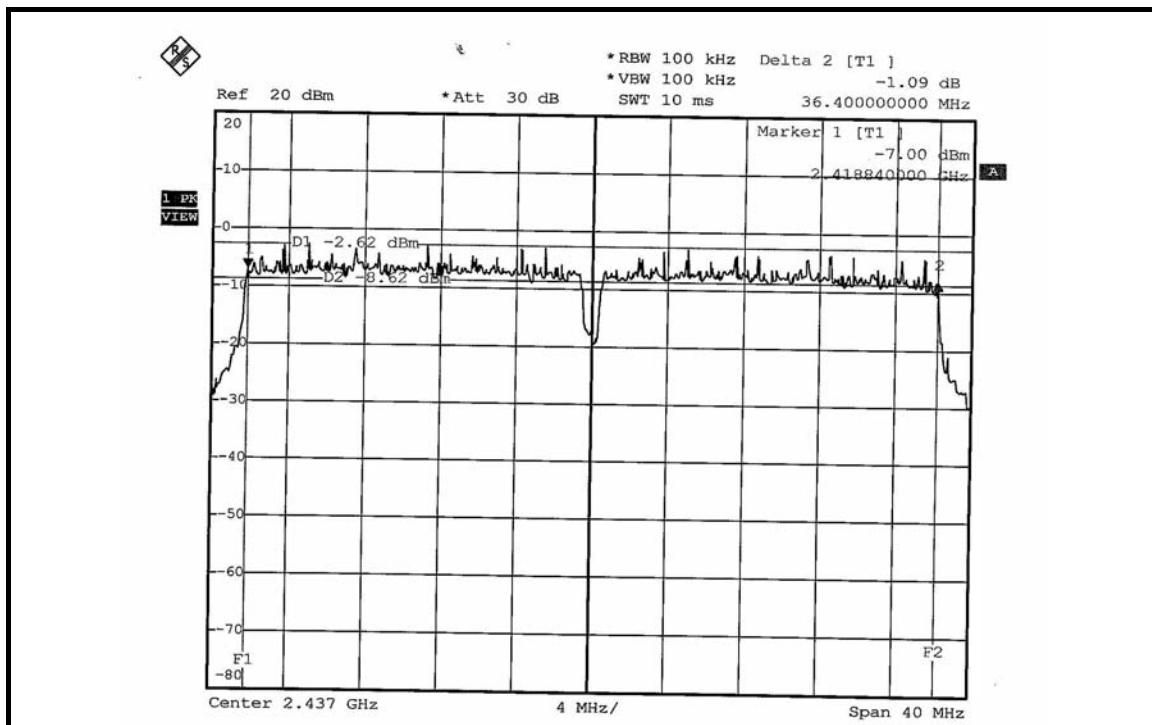

CH 7

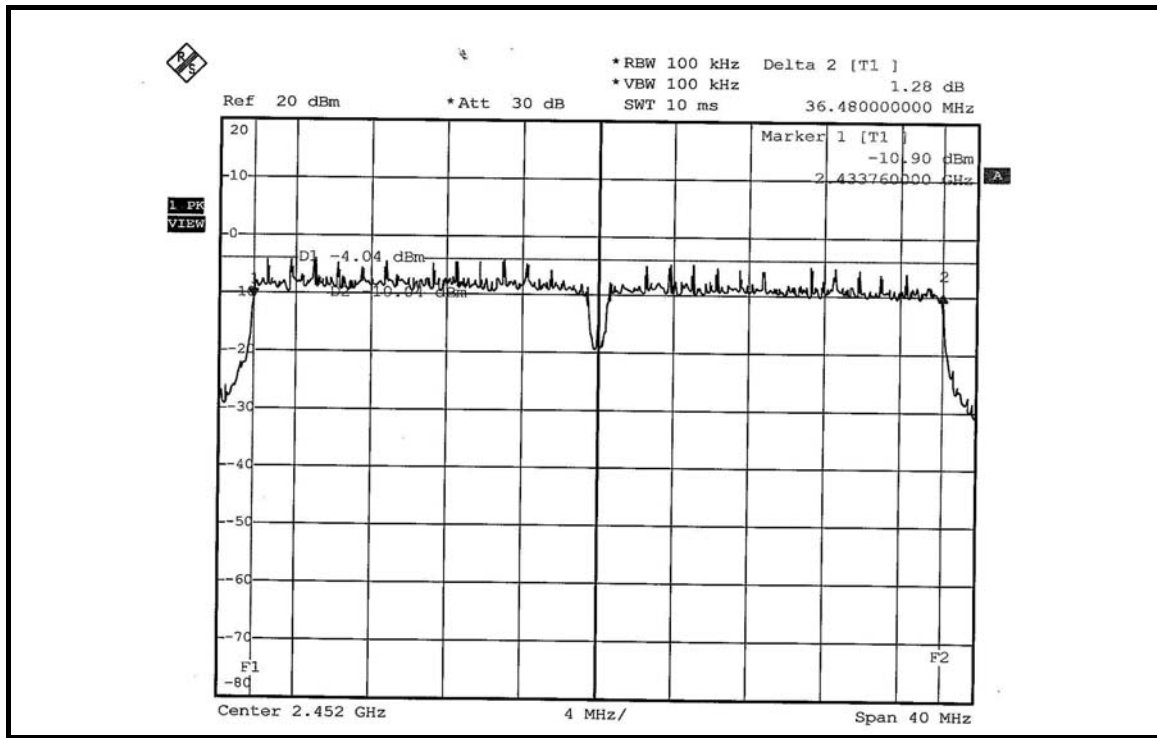



4.4 MAXIMUM PEAK OUTPUT POWER

4.4.1 LIMITS OF MAXIMUM PEAK OUTPUT POWER MEASUREMENT

The Maximum Peak Output Power Measurement is 30dBm.

4.4.2 INSTRUMENTS

DESCRIPTION & MANUFACTURER	MODEL NO.	SERIAL NO.	CALIBRATED UNTIL
R&S SPECTRUM ANALYZER	FSP40	100040	Jun. 07, 2007
AGILENT SIGNAL GENERATOR	E8257C	MY43320668	Dec. 07, 2006
DIGITAL RT OSCILLOSCOPE	TDS1012	C037299	Nov. 28, 2006
NARDA DETECTOR	4503A	FSCM99899	NA

NOTE: The calibration interval of the above test instruments is 12 months and the calibrations are traceable to NML/ROC and NIST/USA.

4.4.3 TEST PROCEDURES

- a. A detector was used on the output port of the EUT. An oscilloscope was used to read the response of the detector.
- b. Replaced the EUT by the signal generator. The center frequency of the S.G was adjusted to the center frequency of the measured channel.
- c. Adjusted the power to have the same reading on oscilloscope. Record the power level.

4.4.4 DEVIATION FROM TEST STANDARD

No deviation

4.4.5 TEST SETUP

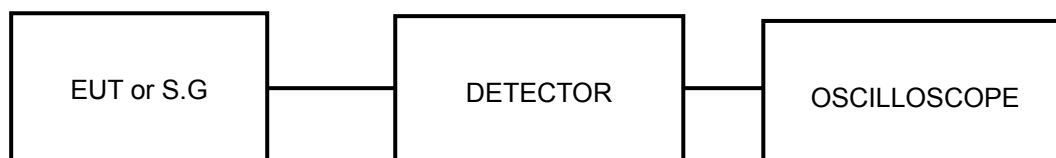

4.4.6 EUT OPERATING CONDITIONS

Same as Item 4.3.6



4.4.7 TEST RESULTS

802.11b DSSS MODULATION: DUAL TX

MODULATION TYPE	DBPSK	TRANSFER RATE	1.0Mbps
INPUT POWER (SYSTEM)	120Vac, 60 Hz	ENVIRONMENTAL CONDITIONS	25deg.C, 63%RH, 991hPa
TESTED BY	Long Chen		

CHAN.	CHANNEL FREQUENCY (MHz)	PEAK POWER OUTPUT (mW)		PEAK POWER OUTPUT (dBm)		TOTAL PEAK POWER (mW)	TOTAL PEAK POWER (dBm)	PEAK POWER LIMIT (dBm)	PASS / FAIL
		CHAIN 0	CHAIN 1	CHAIN 0	CHAIN 1				
1	2412	45.186	43.351	16.55	16.37	88.537	19.47	30	PASS
6	2437	39.902	37.757	16.01	15.77	77.659	18.90	30	PASS
11	2462	35.727	34.594	15.53	15.39	70.321	18.47	30	PASS

802.11g OFDM MODULATION: DUAL TX

MODULATION TYPE	BPSK	TRANSFER RATE	6.0Mbps
INPUT POWER (SYSTEM)	120Vac, 60 Hz	ENVIRONMENTAL CONDITIONS	25deg.C, 63%RH, 991hPa
TESTED BY	Long Chen		

CHAN.	CHANNEL FREQUENCY (MHz)	PEAK POWER OUTPUT (mW)		PEAK POWER OUTPUT (dBm)		TOTAL PEAK POWER (mW)	TOTAL PEAK POWER (dBm)	PEAK POWER LIMIT (dBm)	PASS / FAIL
		CHAIN 0	CHAIN 1	CHAIN 0	CHAIN 1				
1	2412	51.168	48.641	17.09	16.87	99.809	19.99	30	PASS
6	2437	71.779	68.391	18.56	18.35	140.170	21.47	30	PASS
11	2462	50.933	47.098	17.07	16.73	98.031	19.91	30	PASS



DRAFT 802.11n (20MHz) OFDM MODULATION: DUAL TX:

MODULATION TYPE	BPSK	TRANSFER RATE	7.2Mbps
INPUT POWER (SYSTEM)	120Vac, 60 Hz	ENVIRONMENTAL CONDITIONS	25deg.C, 63%RH, 991hPa
TESTED BY	Long Chen		

CHANNEL	CHANNEL FREQUENCY (MHz)	PEAK POWER OUTPUT (mW)		PEAK POWER OUTPUT (dBm)		TOTAL PEAK POWER (mW)	TOTAL PEAK POWER (dBm)	PEAK POWER LIMIT (dBm)	PASS / FAIL
		CHAIN 0	CHAIN 1	CHAIN 0	CHAIN 1				
1	2412	36.058	34.041	15.57	15.32	70.099	18.46	30	PASS
6	2437	50.933	47.863	17.07	16.80	98.796	19.95	30	PASS
11	2462	31.696	30.269	15.01	14.81	61.965	17.92	30	PASS

DRAFT 802.11n (40MHz) OFDM MODULATION: DUAL TX:

MODULATION TYPE	BPSK	TRANSFER RATE	15.0Mbps
INPUT POWER (SYSTEM)	120Vac, 60 Hz	ENVIRONMENTAL CONDITIONS	25deg.C, 63%RH, 991hPa
TESTED BY	Long Chen		

CHANNEL	CHANNEL FREQUENCY (MHz)	PEAK POWER OUTPUT (mW)		PEAK POWER OUTPUT (dBm)		TOTAL PEAK POWER (mW)	TOTAL PEAK POWER (dBm)	PEAK POWER LIMIT (dBm)	PASS / FAIL
		CHAIN 0	CHAIN 1	CHAIN 0	CHAIN 1				
1	2422	22.751	21.429	13.57	13.31	44.180	16.45	30	PASS
4	2437	28.576	26.977	14.56	14.31	55.553	17.45	30	PASS
7	2452	20.091	18.664	13.03	12.71	38.755	15.88	30	PASS



4.5 POWER SPECTRAL DENSITY MEASUREMENT

4.5.1 LIMITS OF POWER SPECTRAL DENSITY MEASUREMENT

The Maximum of Power Spectral Density Measurement is 8dBm.

4.5.2 TEST INSTRUMENTS

DESCRIPTION & MANUFACTURER	MODEL NO.	SERIAL NO.	CALIBRATED UNTIL
R&S SPECTRUM ANALYZER	FSP40	100040	Jun. 07, 2007

NOTE: The calibration interval of the above test instruments is 12 months and the calibrations are traceable to NML/ROC and NIST/USA.

4.5.3 TEST PROCEDURE

The transmitter output was connected to the spectrum analyzer through an attenuator, the bandwidth of the fundamental frequency was measured with the spectrum analyzer using 3kHz RBW and 30kHz VBW, set sweep time = span/3kHz. The power spectral density was measured and recorded.

The sweep time is allowed to be longer than span/3kHz for a full response of the mixer in the spectrum analyzer.

4.5.4 DEVIATION FROM TEST STANDARD

No deviation

4.5.5 TEST SETUP

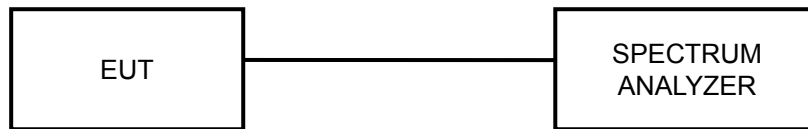

4.5.6 EUT OPERATING CONDITION

Same as Item 4.3.6



4.5.7 TEST RESULTS

802.11b DSSS MODULATION: DUAL TX

MODULATION TYPE	DBPSK	TRANSFER RATE	1.0Mbps
INPUT POWER (SYSTEM)	120Vac, 60 Hz	ENVIRONMENTAL CONDITIONS	25deg.C, 63%RH, 991hPa
TESTED BY	Long Chen		

CHANNEL	CHANNEL FREQUENCY (MHz)	RF POWER LEVEL IN 3kHz BW (mW)		RF POWER LEVEL IN 3kHz BW (dBm)		TOTAL POWER DENSITY (mW)	TOTAL POWER DENSITY (dBm)	MAX. LIMIT (dBm)	PASS / FAIL
		CHAIN 0	CHAIN 1	CHAIN 0	CHAIN 1				
1	2412	0.177	0.171	-7.51	-7.67	0.348	-4.58	8	PASS
6	2437	0.152	0.144	-8.19	-8.43	0.296	-5.30	8	PASS
11	2462	0.132	0.129	-8.78	-8.90	0.261	-5.83	8	PASS

FOR CHAIN 0: CH 1

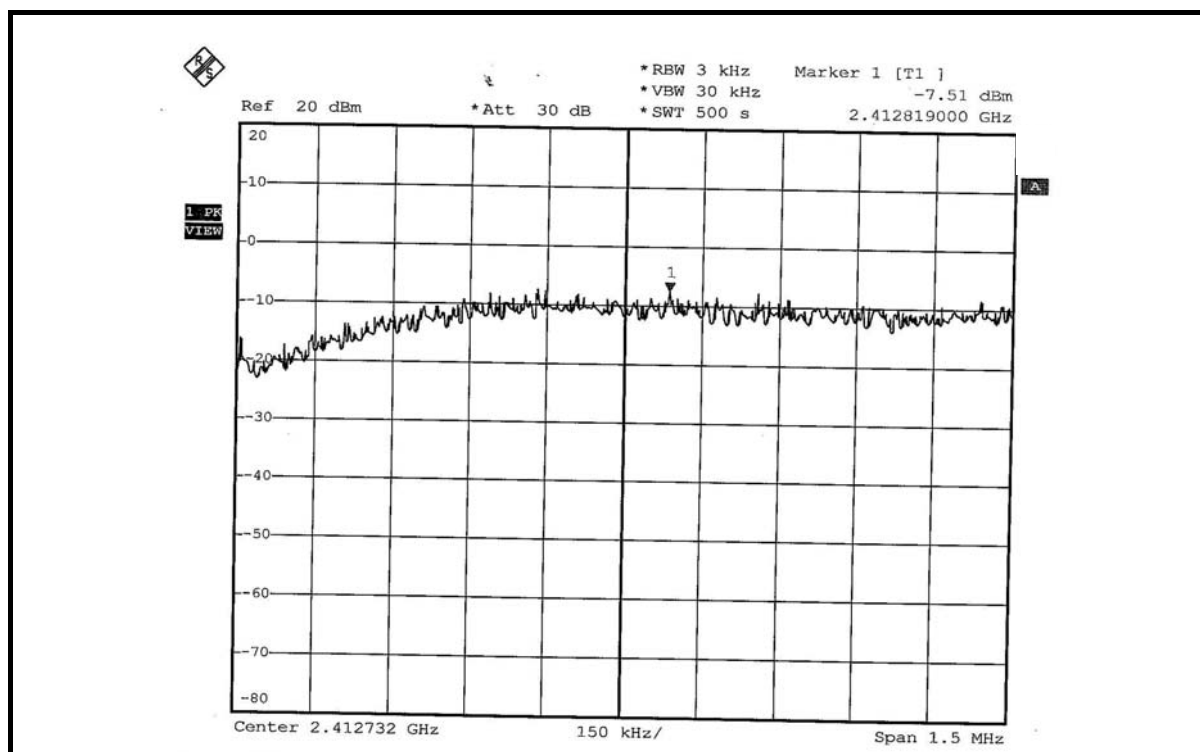

CH 6

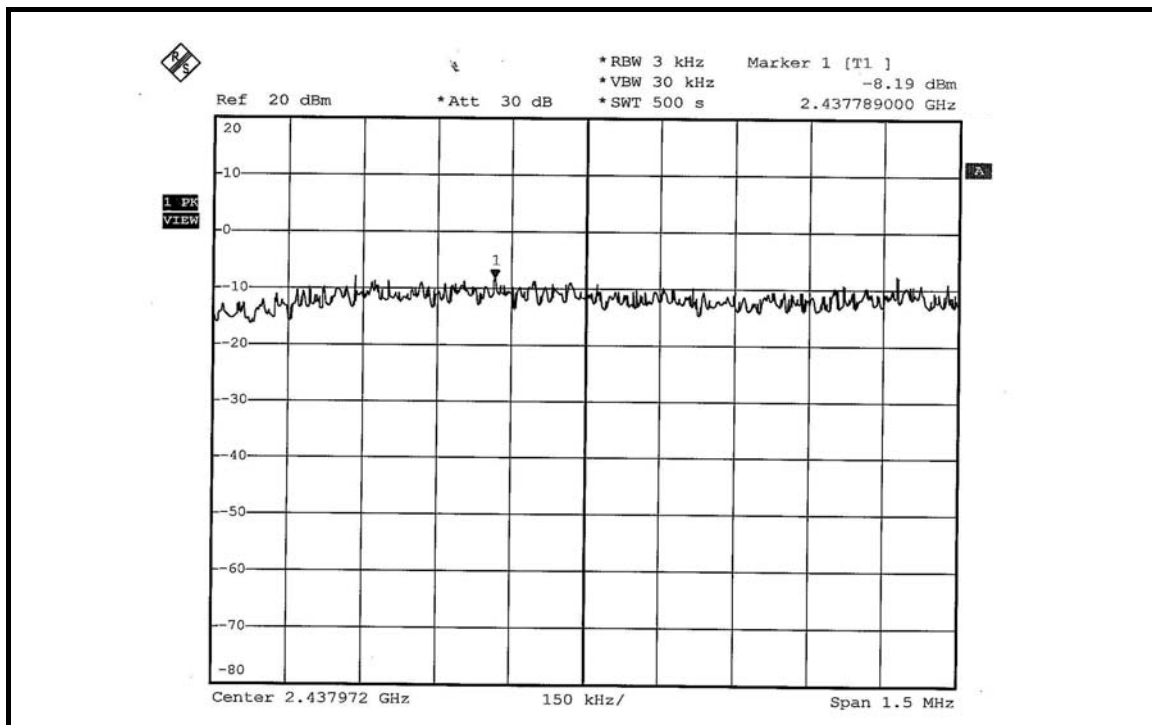

CH 11

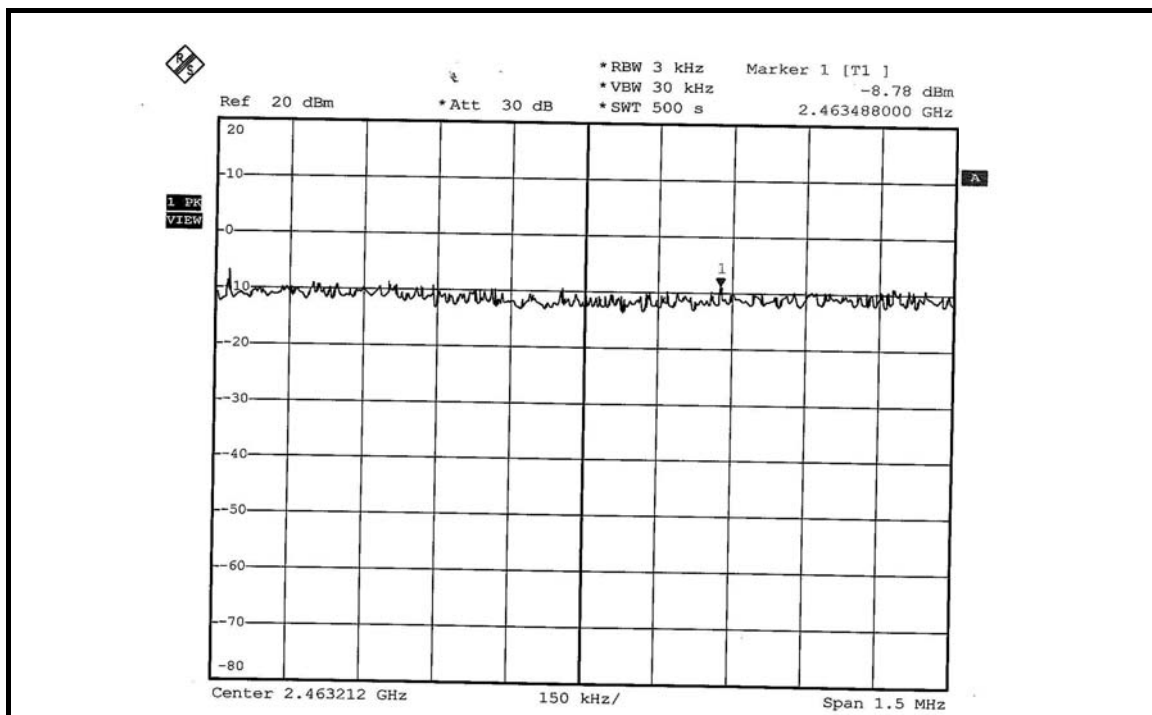

FOR CHAIN 1: CH 1

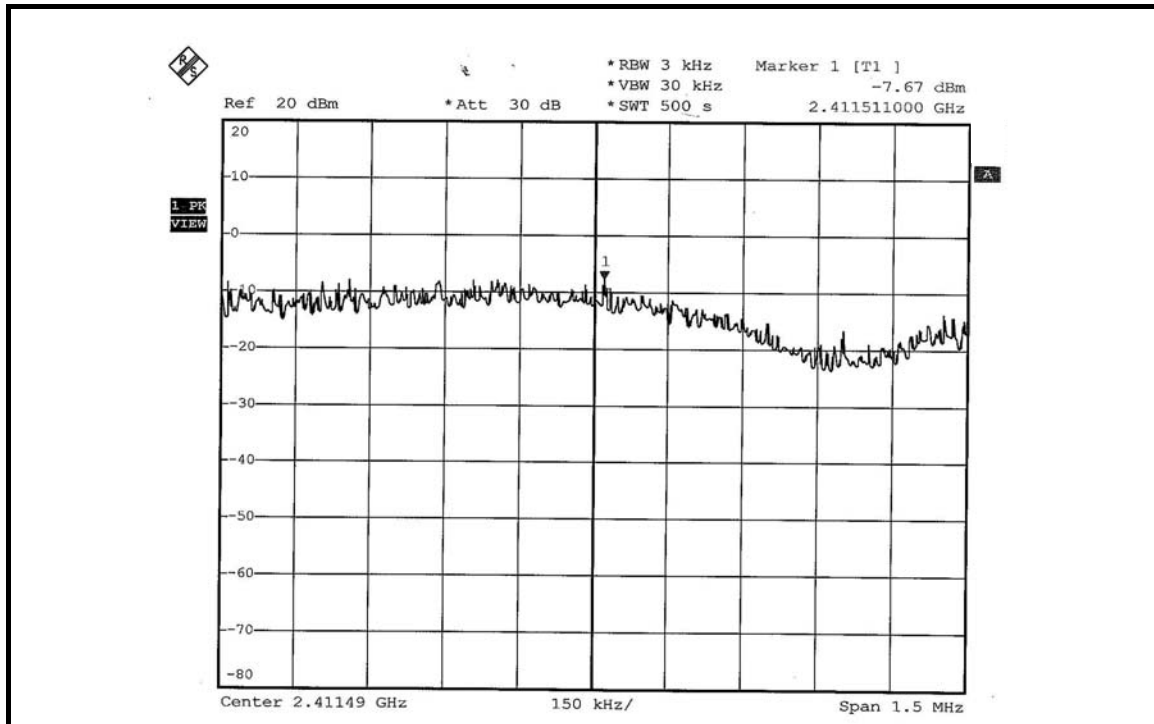

CH 6

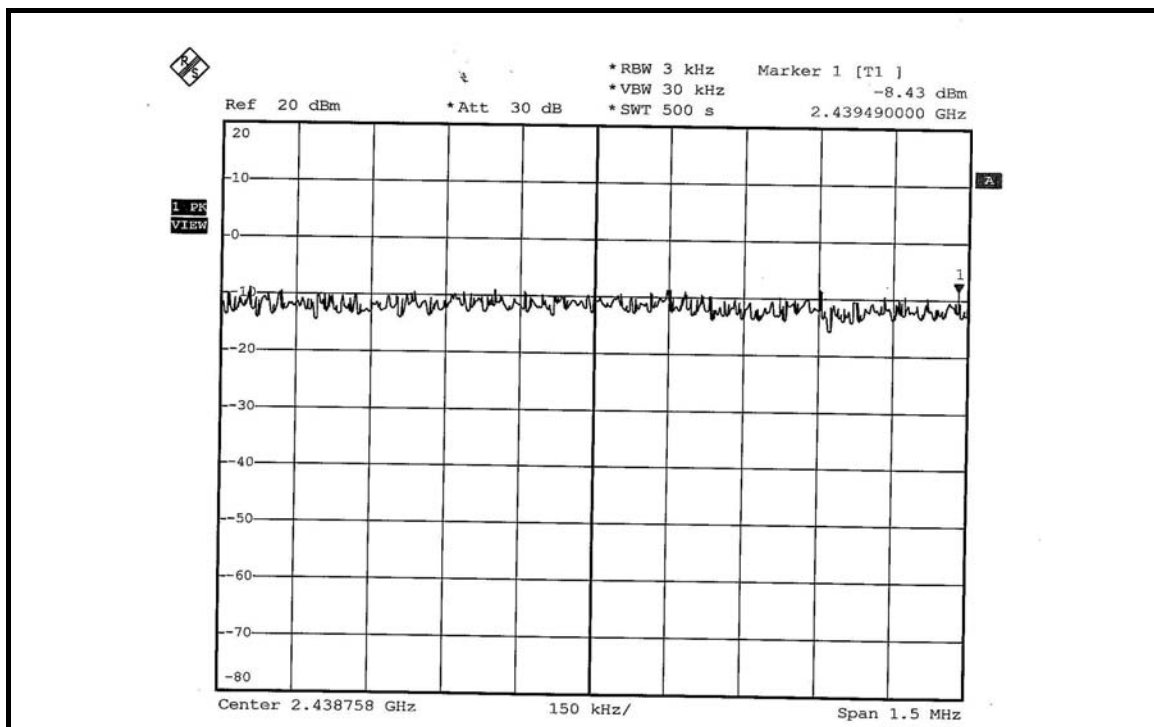

CH 11

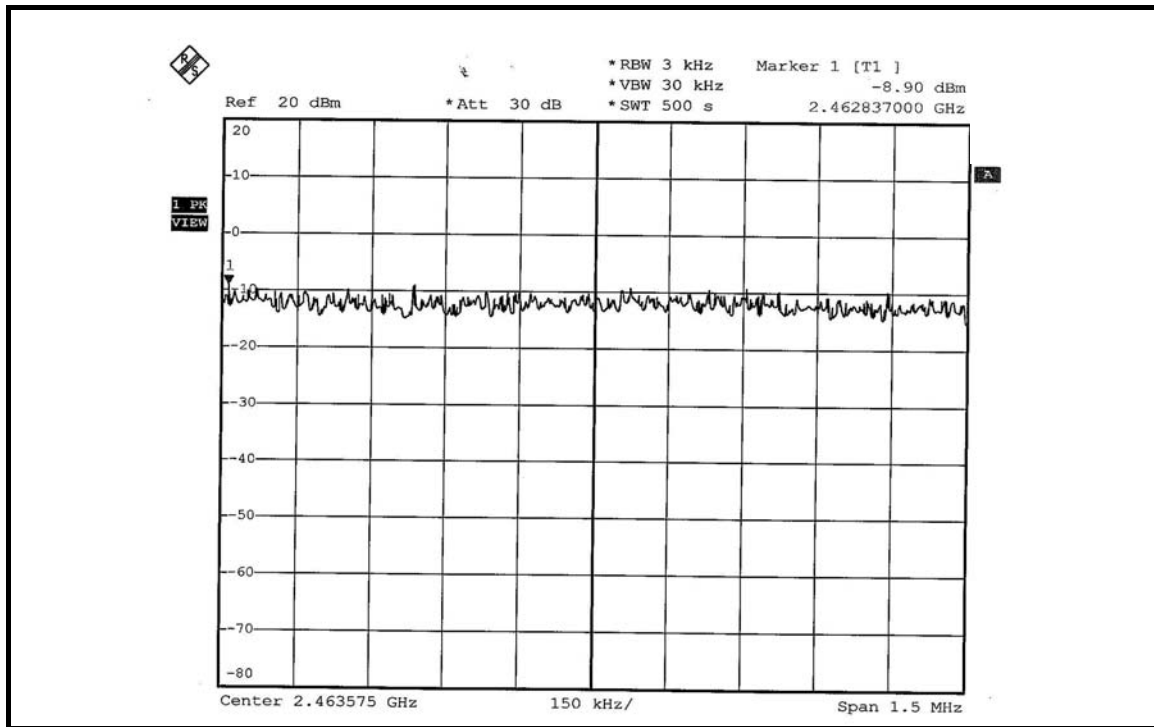



802.11g OFDM MODULATION: DUAL TX

MODULATION TYPE	BPSK	TRANSFER RATE	6.0Mbps
INPUT POWER (SYSTEM)	120Vac, 60 Hz	ENVIRONMENTAL CONDITIONS	25deg.C, 63%RH, 991hPa
TESTED BY	Long Chen		

CHANNEL	CHANNEL FREQUENCY (MHz)	RF POWER LEVEL IN 3kHz BW (mW)		RF POWER LEVEL IN 3kHz BW (dBm)		TOTAL POWER DENSITY (mW)	TOTAL POWER DENSITY (dBm)	MAX. LIMIT (dBm)	PASS / FAIL
		CHAIN 0	CHAIN 1	CHAIN 0	CHAIN 1				
1	2412	0.108	0.102	-9.66	-9.91	0.210	-6.77	8	PASS
6	2437	0.149	0.148	-8.28	-8.30	0.297	-5.28	8	PASS
11	2462	0.111	0.108	-9.55	-9.68	0.219	-6.60	8	PASS

FOR CHAIN 0: CH 1

