



# SAR TEST REPORT

**REPORT NO.:** SA980424L09

**MODEL NO.:** DWA-130E1

**RECEIVED:** Apr. 23, 2009

**TESTED:** May 11, 2009

**ISSUED:** May 18, 2009

**APPLICANT:** D-Link Corporation

**ADDRESS:** 17595 Mt. Herrmann, Fountain Valley, CA 92708,  
U.S.A.

**ISSUED BY:** Bureau Veritas Consumer Products Services  
(H.K.) Ltd., Taoyuan Branch

**LAB ADDRESS:** No. 47, 14th Ling, Chia Pau Tsuen, Lin Kou  
Hsiang, Taipei Hsien 244, Taiwan, R.O.C.

**TEST LOCATION:** No. 19, Hwa Ya 2nd Rd, Wen Hwa Tsuen, Kwei  
Shan Hsiang, Taoyuan Hsien 333, Taiwan, R.O.C.

This test report consists of 41 pages in total except Appendix. It may be duplicated completely for legal use with the approval of the applicant. It should not be reproduced except in full, without the written approval of our laboratory. The client should not use it to claim product endorsement by TAF or any government agencies. The test results in the report only apply to the tested sample.





## TABLE OF CONTENTS

1.	CERTIFICATION .....	3
2.	GENERAL INFORMATION .....	4
2.1	GENERAL DESCRIPTION OF EUT.....	4
2.2	GENERAL DESCRIPTION OF APPLIED STANDARDS.....	5
2.3	GENERAL INFORMATION OF THE SAR SYSTEM.....	6
2.4	GENERAL DESCRIPTION OF THE SPATIAL PEAK SAR EVALUATION .....	9
3.	DESCRIPTION OF SUPPORT UNITS.....	12
4.	DESCRIPTION OF TEST MODES AND CONFIGURATIONS.....	13
4.1.	DESCRIPTION OF ANTENNA LOCATION.....	13
4.2.	DESCRIPTION OF ASSESSMENT POSITION .....	14
4.3.	DESCRIPTION OF TEST MODE .....	15
4.4.	SUMMARY OF TEST RESULTS.....	17
4.5.	CHECK FOR SCAN RESOLUTION.....	18
5.	TEST RESULTS.....	19
5.1	TEST PROCEDURES.....	19
5.2	MEASURED SAR RESULTS .....	21
5.3	SAR LIMITS .....	24
5.4	RECIPES FOR TISSUE SIMULATING LIQUIDS.....	25
5.5	TEST EQUIPMENT FOR TISSUE PROPERTY.....	28
6.	SYSTEM VALIDATION.....	29
6.1	TEST EQUIPMENT .....	29
6.2	TEST PROCEDURE .....	30
6.3	VALIDATION RESULTS .....	32
6.4	SYSTEM VALIDATION UNCERTAINTIES .....	33
7.	MEASUREMENT SAR PROCEDURE UNCERTAINTIES .....	34
7.1.	PROBE CALIBRATION UNCERTAINTY .....	34
7.2.	ISOTROPY UNCERTAINTY .....	35
7.3.	BOUNDARY EFFECT UNCERTAINTY .....	35
7.4.	PROBE LINEARITY UNCERTAINTY .....	36
7.5.	READOUT ELECTRONICS UNCERTAINTY.....	36
7.6.	RESPONSE TIME UNCERTAINTY .....	36
7.7.	INTEGRATION TIME UNCERTAINTY.....	37
7.8.	PROBE POSITIONER MECHANICAL TOLERANCE .....	38
7.9.	PROBE POSITIONING .....	38
7.10.	PHANTOM UNCERTAINTY.....	39
7.11.	DASY4 UNCERTAINTY BUDGET .....	40
8.	INFORMATION ON THE TESTING LABORATORIES.....	41
	APPENDIX A: TEST CONFIGURATIONS AND TEST DATA	
	APPENDIX B: ADT SAR MEASUREMENT SYSTEM	
	APPENDIX C: PHOTOGRAPHS OF SYSTEM VALIDATION	
	APPENDIX D: SYSTEM CERTIFICATE & CALIBRATION	



## 1. CERTIFICATION

**PRODUCT:** Wireless N USB Adapter

**MODEL:** DWA-130E1

**BRAND:** D-Link

**APPLICANT:** D-Link Corporation

**TESTED:** May 11, 2009

**TEST SAMPLE:** ENGINEERING SAMPLE

**STANDARDS:** FCC Part 2 (Section 2.1093)

FCC OET Bulletin 65, Supplement C (01-01)

RSS-102

The above equipment (model: DWA-130E1) has been tested by **Bureau Veritas Consumer Products Services (H.K.) Ltd., Taoyuan Branch**, and found compliance with the requirement of the above standards. The test record, data evaluation & Equipment Under Test (EUT) configurations represented herein are true and accurate accounts of the measurements of the sample's EMC characteristics under the conditions specified in this report.

**PREPARED BY** : Ivy Lin , **DATE:** May 18, 2009  
Ivy Lin / Specialist

**TECHNICAL ACCEPTANCE** : Long Chen , **DATE:** May 18, 2009  
Responsible for RF Long Chen / Senior Engineer

**APPROVED BY** : Gary Chang , **DATE:** May 18, 2009  
Gary Chang / Assistant Manager

## 2. GENERAL INFORMATION

### 2.1 GENERAL DESCRIPTION OF EUT

<b>EUT</b>	Wireless N USB Adapter
<b>MODEL NO.</b>	DWA-130E1
<b>FCC ID</b>	KA2WA130E1
<b>IC ID</b>	4216A-WA130E
<b>POWER SUPPLY</b>	3.3Vdc from host equipment
<b>MODULATION TYPE</b>	CCK, DQPSK, DBPSK for DSSS 64QAM, 16QAM, QPSK, BPSK for OFDM
<b>MODULATION TECHNOLOGY</b>	DSSS, OFDM
<b>TRANSFER RATE</b>	802.11b: 11.0/ 5.5/ 2.0/ 1.0Mbps 802.11g: 54.0/ 48.0/ 36.0/ 24.0/ 18.0/ 12.0/ 9.0/ 6.0Mbps Draft 802.11n: up to 300.0Mbps
<b>FREQUENCY RANGE</b>	2412 ~ 2462MHz
<b>NUMBER OF CHANNEL</b>	11 for 802.11b, 802.11g, draft 802.11n (20MHz) 7 for draft 802.11n (40MHz)
<b>CHANNEL FREQUENCIES UNDER TEST AND ITS CONDUCTED OUTPUT POWER</b>	<b>SAMPLE 1 WITH COMPONENT: EEPROM</b>
	<b>802.11b:</b> 319.890mW / Ch11: 2462MHz
	<b>802.11g:</b> 403.645mW / Ch6: 2437MHz
	<b>DRAFT 802.11n (20MHz):</b> 453.942mW / Ch6: 2437MHz
<b>CHANNEL FREQUENCIES UNDER TEST AND ITS CONDUCTED OUTPUT POWER</b>	<b>DRAFT 802.11n (40MHz):</b> 448.745mW / Ch4: 2437MHz
	<b>SAMPLE 2 WITHOUT COMPONENT: EEPROM</b>
	<b>802.11b:</b> 316.957mW / Ch11: 2462MHz
<b>AVERAGE SAR (1g)</b>	0.689W/kg
<b>ANTENNA TYPE</b>	Printed antenna with 2dBi gain
<b>DATA CABLE</b>	1.0m shielded USB cable for cradle
<b>I/O PORTS</b>	USB
<b>ACCESSORY DEVICES</b>	NA



**NOTE:**

1. The EUT incorporates a MIMO function. Physically, the EUT provides one completed transmitter and two receivers.

MODULATION MODE	TX FUNCTION
802.11b	1TX
802.11g	1TX
Draft 802.11n (20MHz)	1TX
Draft 802.11n (40MHz)	1TX

2. The EUT has two samples, which difference is as below.

Sample	Difference
1	With component: EEprom
2	Without component: EEprom

3. The above EUT information was declared by manufacturer and for more detailed features description, please refer to the manufacturer's specifications or user's manual.

## 2.2 GENERAL DESCRIPTION OF APPLIED STANDARDS

According to the specifications of the manufacturer, this product must comply with the requirements of the following standards:

**FCC Part 2 (2.1093)**

**FCC OET Bulletin 65, Supplement C (01- 01)**

**RSS-102**

**IEEE 1528-2003**

All test items have been performed and recorded as per the above standards.



## 2.3 GENERAL INFORMATION OF THE SAR SYSTEM

DASY4 (software 4.7 Build 80) consists of high precision robot, probe alignment sensor, phantom, robot controller, controlled measurement server and near-field probe. The robot includes six axes that can move to the precision position of the DASY4 software defined. The DASY4 software can define the area that is detected by the probe. The robot is connected to controlled box. Controlled measurement server is connected to the controlled robot box. The DAE includes amplifier, signal multiplexing, AD converter, offset measurement and surface detection. It is connected to the Electro-optical coupler (ECO). The ECO performs the conversion from the optical into digital electric signal of the DAE and transfers data to the PC.

### EX3DV3 ISOTROPIC E-FIELD PROBE

<b>CONSTRUCTION</b>	Symmetrical design with triangular core Built-in shielding against static charges PEEK enclosure material (resistant to organic solvents, e.g., DGBE)
<b>FREQUENCY</b>	10 MHz to > 6 GHz Linearity: $\pm 0.2$ dB (30 MHz to 6 GHz)
<b>DIRECTIVITY</b>	$\pm 0.3$ dB in HSL (rotation around probe axis) $\pm 0.5$ dB in tissue material (rotation normal to probe axis)
<b>DYNAMIC RANGE</b>	10 $\mu$ W/g to > 100 mW/g Linearity: $\pm 0.2$ dB (noise: typically < 1 $\mu$ W/g)
<b>DIMENSIONS</b>	Overall length: 330 mm (Tip: 20 mm) Tip diameter: 2.5 mm (Body: 12 mm) Typical distance from probe tip to dipole centers: 1 mm
<b>APPLICATION</b>	High precision dosimetric measurements in any exposure scenario (e.g., very strong gradient fields). Only probe which enables compliance testing for frequencies up to 6 GHz with precision of better 30%.

#### NOTE

1. The Probe parameters have been calibrated by the SPEAG. Please reference "APPENDIX D" for the Calibration Certification Report.
2. For frequencies above 800MHz, calibration in a rectangular wave-guide is used, because wave-guide size is manageable.
3. For frequencies below 800MHz, temperature transfer calibration is used because the wave-guide size becomes relatively large.



## TWIN SAM V4.0

**CONSTRUCTION** The shell corresponds to the specifications of the Specific Anthropomorphic Mannequin (SAM) phantom defined in IEEE 1528-2003, EN 62209-1 and IEC 62209. It enables the dosimetric evaluation of left and right hand phone usage as well as body mounted usage at the flat phantom region. A cover prevents evaporation of the liquid. Reference markings on the phantom allow the complete setup of all predefined phantom positions and measurement grids by manually teaching three points with the robot.

**SHELL THICKNESS**  $2 \pm 0.2\text{mm}$

**FILLING VOLUME** Approx. 25liters

**DIMENSIONS** Height: 810mm; Length: 1000mm; Width: 500mm

### SYSTEM VALIDATION KITS:

**CONSTRUCTION** Symmetrical dipole with 1/4 balun enables measurement of feedpoint impedance with NWA matched for use near flat phantoms filled with brain simulating solutions. Includes distance holder and tripod adaptor

**CALIBRATION** Calibrated SAR value for specified position and input power at the flat phantom in brain simulating solutions

**FREQUENCY** 2450MHz

**RETURN LOSS** > 20dB at specified validation position

**POWER CAPABILITY** > 100W ( $f < 1\text{GHz}$ ); > 40W ( $f > 1\text{GHz}$ )

**OPTIONS** Dipoles for other frequencies or solutions and other calibration conditions upon request

## DEVICE HOLDER FOR SAM TWIN PHANTOM

### CONSTRUCTION

The device holder for the mobile phone device is designed to cope with different positions given in the standard. It has two scales for the device rotation (with respect to the body axis) and the device inclination (with respect to the line between the ear reference points). The rotation centers for both scales is the ear reference point (ERP). Thus the device needs no repositioning when changing the angles. The holder has been made out of low-loss POM material having the following dielectric parameters: relative permittivity  $\epsilon = 3$  and loss tangent  $\delta = 0.02$ . The amount of dielectric material has been reduced in the closest vicinity of the device, since measurements have suggested that the influence of the clamp on the test results could thus be lowered. The device holder for the portable device makes up of the polyethylene foam. The dielectric parameters of material close to the dielectric parameters of the air.

## DATA ACQUISITION ELECTRONICS

### CONSTRUCTION

The data acquisition electronics (DAE3) consists of a highly sensitive electrometer grade preamplifier with auto-zeroing, a channel and gain-switching multiplex, a fast 16 bit AD converter and a command decoder and control logic unit. Transmission to the measurement server is accomplished through an optical downlink for data and status information as well as an optical uplink for commands and the clock. The mechanical probe is mounting device includes two different sensor systems for frontal and sideways probe contacts. They are used for mechanical surface detection and probe collision detection. The input impedance of the DAE3 box is 200M $\Omega$ ; the inputs are symmetrical and floating. Common mode rejection is above 80 dB.





## 2.4 GENERAL DESCRIPTION OF THE SPATIAL PEAK SAR EVALUATION

The DASY4 post-processing software (SEMCAD) automatically executes the following procedures to calculate the field units from the micro-volt readings at the probe connector. The parameters used in the evaluation are stored in the configuration modules of the software:

Probe parameters:	- Sensitivity	Norm <sub>i</sub> , a <sub>i0</sub> , a <sub>i1</sub> , a <sub>i2</sub>
	- Conversion factor	ConvF <sub>i</sub>
	- Diode compression point	dcp <sub>i</sub>
Device parameters:	- Frequency	F
	- Crest factor	Cf
Media parameters:	- Conductivity	$\sigma$
	- Density	$\rho$

The first step of the evaluation is a linearization of the filtered input signal to account for the compression characteristics of the detector diode. The compensation depends on the input signal, the diode type and the DC-transmission factor from the diode to the evaluation electronics. If the exciting field is pulsed, the crest factor of the signal must be known to correctly compensate for peak power. The formula for each channel can be given as:

$$V_i = U_i + U_i^2 \cdot \frac{cf}{dcp_i}$$

V <sub>i</sub>	=compensated signal of channel i	(i = x, y, z)
U <sub>i</sub>	=input signal of channel i	(i = x, y, z)
Cf	=crest factor of exciting field	(DASY parameter)
dcp <sub>i</sub>	=diode compression point	(DASY parameter)

From the compensated input signals the primary field data for each channel can be evaluated:

$$\text{E-field probes: } E_i = \sqrt{\frac{V_i}{\text{Norm}_i \cdot \text{ConvF}}}$$

$$\text{H-field probes: } H_i = \sqrt{V_i} \cdot \frac{a_{i0} + a_{i1}f + a_{i2}f^2}{f}$$

- $V_i$  = compensated signal of channel I (i = x, y, z)
- $\text{Norm}_i$  = sensor sensitivity of channel i  $\mu\text{V}/(\text{V/m})^2$  for E-field Probes (i = x, y, z)
- $\text{ConvF}$  = sensitivity enhancement in solution
- $a_{ij}$  = sensor sensitivity factors for H-field probes
- $f$  = carrier frequency [GHz]
- $E_i$  = electric field strength of channel i in V/m
- $H_i$  = magnetic field strength of channel i in A/m

The RSS value of the field components gives the total field strength (Hermitian magnitude):

$$E_{tot} = \sqrt{E_x^2 + E_y^2 + E_z^2}$$

The primary field data are used to calculate the derived field units.

$$\text{SAR} = E_{tot}^2 \cdot \frac{\sigma}{\rho \cdot 1'000}$$

- $\text{SAR}$  = local specific absorption rate in mW/g
- $E_{tot}$  = total field strength in V/m
- $\sigma$  = conductivity in [mho/m] or [Siemens/m]
- $\rho$  = equivalent tissue density in g/cm<sup>3</sup>



Note that the density is set to 1, to account for actual head tissue density rather than the density of the tissue simulating liquid. The entire evaluation of the spatial peak values is performed within the Post-processing engine (SEMCAD). The system always gives the maximum values for the 1g and 10g cubes. The algorithm to find the cube with highest averaged SAR is divided into the following stages:

1. The extraction of the measured data (grid and values) from the Zoom Scan
2. The calculation of the SAR value at every measurement point based on all stored data (A/D values and measurement parameters)
3. The generation of a high-resolution mesh within the measured volume
4. The interpolation of all measured values from the measurement grid to the high-resolution grid
5. The extrapolation of the entire 3-D field distribution to the phantom surface over the distance from sensor to surface
6. The calculation of the averaged SAR within masses of 1g and 10g.

The probe is calibrated at the center of the dipole sensors that is located 1 to 2.7mm away from the probe tip. During measurements, the probe stops shortly above the phantom surface, depending on the probe and the surface detecting system. Both distances are included as parameters in the probe configuration file. The software always knows exactly how far away the measured point is from the surface. As the probe cannot directly measure at the surface, the values between the deepest measured point and the surface must be extrapolated. The angle between the probe axis and the surface normal line is less than 30 degree.



The maximum search is automatically performed after each area scan measurement. It is based on splines in two or three dimensions. The procedure can find the maximum for most SAR distributions even with relatively large grid spacing. After the area scanning measurement, the probe is automatically moved to a position at the interpolated maximum. The following scan can directly use this position for reference, e.g., for a finer resolution grid or the cube evaluations. The 1g and 10g peak evaluations are only available for the predefined cube 7 x 7 x 7 scans. The routines are verified and optimized for the grid dimensions used in these cube measurements. The measured volume of 30 x 30 x 30mm contains about 30g of tissue. The first procedure is an extrapolation (incl. boundary correction) to get the points between the lowest measured plane and the surface. The next step uses 3D interpolation to get all points within the measured volume in a 1mm grid (42875 points). In the last step, a 1g cube is placed numerically into the volume and its averaged SAR is calculated. This cube is the moved around until the highest averaged SAR is found. If the highest SAR is found at the edge of the measured volume, the system will issue a warning: higher SAR values might be found outside of the measured volume. In that case the cube measurement can be repeated, using the new interpolated maximum as the center.

### 3. DESCRIPTION OF SUPPORT UNITS

The EUT has been tested as an independent unit together with other necessary accessories or support units. The following support units or accessories were used to form a representative test configuration during the tests.

NO.	PRODUCT	BRAND	MODEL NO.	SERIAL NO.	FCC ID
1	NOTEBOOK	DELL	PP18L	29144041120	CXSMM01BRD02D330

NO.	SIGNAL CABLE DESCRIPTION OF THE ABOVE SUPPORT UNITS
1	NA

**NOTE:** The length of USB cable is 11.6 inch. USB cable does not affect device radiating characteristics and output power.

## 4. DESCRIPTION OF TEST MODES AND CONFIGURATIONS

### 4.1. DESCRIPTION OF ANTENNA LOCATION



## 4.2. DESCRIPTION OF ASSESSMENT POSITION

The following test configurations have been applied in this test report:

<p style="text-align: center;"><b>A</b></p> <p>The bottom of the EUT faces to the phantom with 5mm-separation distance.</p>	<p style="text-align: center;"><b>B</b></p> <p>The right edge of the EUT faces to the phantom with 5mm-separation distance.</p>
<p style="text-align: center;"><b>C</b></p> <p>The front of the EUT faces to the phantom with 5mm-separation distance.</p>	<p style="text-align: center;"><b>D</b></p> <p>The left edge of the EUT faces to the phantom with 5mm-separation distance.</p>
<p style="text-align: center;"><b>E</b></p> <p>The tip of the EUT faces to the phantom with 5mm-separation distance.</p>	<p style="text-align: center;"><b>SETUP PHOTO</b></p>



### 4.3. DESCRIPTION OF TEST MODE

Test tool is MP819xVC 0.20.309.2009 provided by client. It can control EUT to transmit continuously at specific channel, output power level, data rates and 100 % duty signal.

This EUT supports 1 TX / 2 RX function. TX antenna diversity function is not supported for this EUT. Only antenna 1 can transmit. Therefore, all test modes are done under antenna 1 transmitting.

“Per KDB 248277, for each frequency band, testing at higher data rates and higher order modulations is not required when the maximum average output power for each of these configurations is less than  $\frac{1}{4}$  dB higher than those measured at the lowest data rate.”

Comparing output power of all modulations and data rates of each mode can find the lowest data rates has max output power. Therefore, EUT will set under lowest data rates to test.

“Per KDB 447498, when the SAR procedures require multiple channels to be tested and the 1-g SAR for the highest output channel is less than 0.8 W/kg and peak SAR is less than 1.6 W/kg, where the transmission band corresponding to all channels is  $\leq 100$  MHz, testing for the other channels is not required.”

According to test data from table of section 4.4, SAR value of highest output power channel is less than 0.8 W/ kg and peak SAR is less than 1.6 W/kg. Therefore, testing for other channels is not required.

ITEM	TEST MODE	MODULATION	ASSESSMENT POSITION	TESTED CHANNEL	SAMPLE
1	802.11b	DBPSK	A	11	Sample 1
2	802.11b	DBPSK		11	Sample 2
3	802.11g	BPSK		6	Sample 1
4	Draft 802.11n (20MHz)	BPSK		6	Sample 1
5	Draft 802.11n (40MHz)	BPSK		4	Sample 1
6	802.11b	DBPSK	B	11	Sample 1
7	802.11b	DBPSK		11	Sample 2
8	802.11g	BPSK		6	Sample 1
9	Draft 802.11n (20MHz)	BPSK		6	Sample 1
10	Draft 802.11n (40MHz)	BPSK		4	Sample 1
11	802.11b	DBPSK	C	11	Sample 1
12	802.11b	DBPSK		11	Sample 2
13	802.11g	BPSK		6	Sample 1
14	Draft 802.11n (20MHz)	BPSK		6	Sample 1
15	Draft 802.11n (40MHz)	BPSK		4	Sample 1
16	802.11b	DBPSK	D	11	Sample 1
17	802.11b	DBPSK		11	Sample 2
18	802.11g	BPSK		6	Sample 1
19	Draft 802.11n (20MHz)	BPSK		6	Sample 1
20	Draft 802.11n (40MHz)	BPSK		4	Sample 1
21	802.11b	DBPSK	E	11	Sample 1
22	802.11b	DBPSK		11	Sample 2
23	802.11g	BPSK		6	Sample 1
24	Draft 802.11n (20MHz)	BPSK		6	Sample 1
25	Draft 802.11n (40MHz)	BPSK		4	Sample 1



#### 4.4. SUMMARY OF TEST RESULTS

ITEM		1	2	3	4	ITEM		5
TEST MODE		802.11b		802.11g	DRAFT 802.11n (20MHz)	TEST MODE		DRAFT 802.11n (40MHz)
CHAN.	FREQ. (MHz)	MEASURED VALUE OF 1g SAR ( W/kg)				CHAN.	FREQ. (MHz)	MEASURED VALUE OF 1g SAR ( W/kg)
1	2412 (Low)	-	-	-	-	1	2422 (Low)	-
6	2437 (Mid.)	-	-	0.436	0.436	4	2437 (Mid.)	0.333
11	2462 (High)	0.689	0.608	-	-	7	2452 (High)	-

ITEM		6	7	8	9	ITEM		10
TEST MODE		802.11b		802.11g	DRAFT 802.11n (20MHz)	TEST MODE		DRAFT 802.11n (40MHz)
CHAN.	FREQ. (MHz)	MEASURED VALUE OF 1g SAR ( W/kg)				CHAN.	FREQ. (MHz)	MEASURED VALUE OF 1g SAR ( W/kg)
1	2412 (Low)	-	-	-	-	1	2422 (Low)	-
6	2437 (Mid.)	-	-	0.399	0.386	4	2437 (Mid.)	0.322
11	2462 (High)	0.649	0.591	-	-	7	2452 (High)	-

ITEM		11	12	13	14	ITEM		15
TEST MODE		802.11b		802.11g	DRAFT 802.11n (20MHz)	TEST MODE		DRAFT 802.11n (40MHz)
CHAN.	FREQ. (MHz)	MEASURED VALUE OF 1g SAR ( W/kg)				CHAN.	FREQ. (MHz)	MEASURED VALUE OF 1g SAR ( W/kg)
1	2412 (Low)	-	-	-	-	1	2422 (Low)	-
6	2437 (Mid.)	-	-	0.323	0.312	4	2437 (Mid.)	0.237
11	2462 (High)	0.421	0.390	-	-	7	2452 (High)	-

ITEM		16	17	18	19	ITEM		20
TEST MODE		802.11b		802.11g	DRAFT 802.11n (20MHz)	TEST MODE		DRAFT 802.11n (40MHz)
CHAN.	FREQ. (MHz)	MEASURED VALUE OF 1g SAR ( W/kg)				CHAN.	FREQ. (MHz)	MEASURED VALUE OF 1g SAR ( W/kg)
1	2412 (Low)	-	-	-	-	1	2422 (Low)	-
6	2437 (Mid.)	-	-	0.085	0.096	4	2437 (Mid.)	0.071
11	2462 (High)	0.155	0.144	-	-	7	2452 (High)	-

ITEM		21	22	23	24	ITEM		25
TEST MODE		802.11b		802.11g	DRAFT 802.11n (20MHz)	TEST MODE		DRAFT 802.11n (40MHz)
CHAN.	FREQ. (MHz)	MEASURED VALUE OF 1g SAR ( W/kg)				CHAN.	FREQ. (MHz)	MEASURED VALUE OF 1g SAR ( W/kg)
1	2412 (Low)	-	-	-	-	1	2422 (Low)	-
6	2437 (Mid.)	-	-	0.076	0.075	4	2437 (Mid.)	0.059
11	2462 (High)	0.097	0.088	-	-	7	2452 (High)	-

#### 4.5. CHECK FOR SCAN RESOLUTION

##### COMPARE WITH DIFFERENT SCAN RESOLUTION

With EUT hold on the worst case configuration (High channel in test mode 1) with no any change in position or setting, 2 scans with different resolutions are performed to evaluate the impact on the SAR value.

Test data as below:

SCAN RESOLUTION (mm)	SAR VALUE (W/kg)
5	0.689
2.5	0.676

**CONCLUSION:** No meaningful change detected.



## **5. TEST RESULTS**

### **5.1 TEST PROCEDURES**

The EUT plugged into the notebook. Use the software to control the EUT channel and transmission power. Then record the conducted power before the testing. Place the EUT to the specific test location. After the testing, must writing down the conducted power of the EUT into the report. The SAR value was calculated via the 3D spline interpolation algorithm that has been implemented in the software of DASY4 SAR measurement system manufactured and calibrated by SPEAG. According to the IEEE 1528 standards, the recommended procedure for assessing the peak spatial-average SAR value consists of the following steps:

- Power reference measurement
- Verification of the power reference measurement
- Area scan
- Zoom scan
- Power reference measurement

The area scan was performed for the highest spatial SAR location. The zoom scan with 30mm x 30mm x 30mm volume was performed for SAR value averaged over 1g and 10g spatial volumes.



In the zoom scan, the distance between the measurement point at the probe sensor location (geometric center behind the probe tip) and the phantom surface is 3mm and maintained at a constant distance of  $\pm 0.5\text{mm}$  during a zoom scan to determine peak SAR locations. The distance is 3mm between the first measurement point and the bottom surface of the phantom. The secondary measurement point to the bottom surface of the phantom is with 8mm separation distance. The cube size is  $7 \times 7 \times 7$  points consists of 343 points and the grid space is 5mm.

The measurement time is 0.5s at each point of the zoom scan. The probe boundary effect compensation shall be applied during the SAR test. Because of the tip of the probe to the Phantom surface separated distances are longer than half a tip probe diameter.

In the area scan, the separation distance is 3mm between the each measurement point and the phantom surface. The scan size shall be included the transmission portion of the EUT. The measurement time is the same as the zoom scan. At last the reference power drift shall be less than  $\pm 5\%$ .

## 5.2 MEASURED SAR RESULTS

ENVIRONMENTAL CONDITION			Air Temperature : 23.5°C, Liquid Temperature : 22.2°C Humidity : 60%RH				
TESTED BY			Sam Onn		DATE	May 11, 2009	
CHAN.	FREQ. (MHz)	TEST MODE	CONDUCTED POWER (mW)		POWER DRIFT (%)	DEVICE TEST POSITION MODE	MEASURED 1g SAR (W/kg)
			BEGIN TEST	AFTER TEST			
11	2462 (High)	802.11b	319.890	316.115	-1.18%	1	<b>0.689</b>
11	2462 (High)	802.11b	316.957	312.963	-1.26%	2	0.608
6	2437 (Mid.)	802.11g	403.645	398.236	-1.34%	3	0.436
6	2437 (Mid.)	DRAFT 802.11n (20MHz)	453.942	447.314	-1.46%	4	0.436
4	2437 (Mid.)	DRAFT 802.11n (40MHz)	448.745	441.924	-1.52%	5	0.333
11	2462 (High)	802.11b	319.890	314.484	-1.69%	6	0.649
11	2462 (High)	802.11b	316.957	311.442	-1.74%	7	0.591
6	2437 (Mid.)	802.11g	403.645	396.056	-1.88%	8	0.399
6	2437 (Mid.)	DRAFT 802.11n (20MHz)	453.942	445.090	-1.95%	9	0.386
4	2437 (Mid.)	DRAFT 802.11n (40MHz)	448.745	439.501	-2.06%	10	0.322

**NOTE:**

1. Test configuration of each mode is described in section 4.3.
2. In this testing, the limit for General Population Spatial Peak averaged over 1g, 1.6 W/kg, is applied.
3. Please see the Appendix A for the data.
4. The variation of the EUT conducted power measured before and after SAR testing should not over 5%.



ENVIRONMENTAL CONDITION			Air Temperature : 23.5°C, Liquid Temperature : 22.2°C Humidity : 60%RH				
TESTED BY			Sam Onn		DATE		May 11, 2009
CHAN.	FREQ. (MHz)	TEST MODE	CONDUCTED POWER (mW)		POWER DRIFT (%)	DEVICE TEST POSITION MODE	MEASURED 1g SAR (W/kg)
			BEGIN TEST	AFTER TEST			
11	2462 (High)	802.11b	319.890	317.875	-0.63%	11	0.421
11	2462 (High)	802.11b	316.957	314.612	-0.74%	12	0.390
6	2437 (Mid.)	802.11g	403.645	400.214	-0.85%	13	0.323
6	2437 (Mid.)	DRAFT 802.11n (20MHz)	453.942	449.720	-0.93%	14	0.312
4	2437 (Mid.)	DRAFT 802.11n (40MHz)	448.745	444.168	-1.02%	15	0.237
11	2462 (High)	802.11b	319.89	316.147	-1.17%	16	0.155
11	2462 (High)	802.11b	316.957	313.090	-1.22%	17	0.144
6	2437 (Mid.)	802.11g	403.645	398.034	-1.39%	18	0.085
6	2437 (Mid.)	DRAFT 802.11n (20MHz)	453.942	447.360	-1.45%	19	0.096
4	2437 (Mid.)	DRAFT 802.11n (40MHz)	448.745	441.745	-1.56%	20	0.071

**NOTE:**

1. Test configuration of each mode is described in section 4.3.
2. In this testing, the limit for General Population Spatial Peak averaged over 1g, 1.6 W/kg, is applied.
3. Please see the Appendix A for the data.
4. The variation of the EUT conducted power measured before and after SAR testing should not over 5%.



<b>ENVIRONMENTAL CONDITION</b>			Air Temperature : 23.5°C, Liquid Temperature : 22.2°C Humidity : 60%RH				
<b>TESTED BY</b>			Sam Onn		<b>DATE</b>	May 11, 2009	
CHAN.	FREQ. (MHz)	TEST MODE	CONDUCTED POWER (mW)		POWER DRIFT (%)	DEVICE TEST POSITION MODE	MEASURED 1g SAR (W/kg)
			BEGIN TEST	AFTER TEST			
11	2462 (High)	802.11b	319.890	314.516	-1.68%	21	0.097
11	2462 (High)	802.11b	316.957	311.474	-1.73%	22	0.088
6	2437 (Mid.)	802.11g	403.645	396.137	-1.86%	23	0.076
6	2437 (Mid.)	DRAFT 802.11n (20MHz)	453.942	445.181	-1.93%	24	0.075
4	2437 (Mid.)	DRAFT 802.11n (40MHz)	448.745	439.635	-2.03%	25	0.059

**NOTE:**

1. Test configuration of each mode is described in section 4.3.
2. In this testing, the limit for General Population Spatial Peak averaged over 1g, 1.6 W/kg, is applied.
3. Please see the Appendix A for the data.
4. The variation of the EUT conducted power measured before and after SAR testing should not over 5%.



### 5.3 SAR LIMITS

HUMAN EXPOSURE	SAR (W/kg)	
	(GENERAL POPULATION / UNCONTROLLED EXPOSURE ENVIRONMENT)	(OCCUPATIONAL / CONTROLLED EXPOSURE ENVIRONMENT)
Spatial Average (whole body)	0.08	0.4
Spatial Peak (averaged over 1 g)	1.6	8.0
Spatial Peak (hands / wrists / feet / ankles averaged over 10 g)	4.0	20.0

**NOTE:**

1. This limits accord to 47 CFR 2.1093 – Safety Limit.
2. The EUT property been complied with the partial body exposure limit under the general population environment.



## 5.4 RECIPES FOR TISSUE SIMULATING LIQUIDS

For the measurement of the field distribution inside the SAM phantom, the phantom must be filled with 25 liters of tissue simulation liquid.

The following ingredients are used :

- **WATER-** Deionized water (pure H<sub>2</sub>O), resistivity  $\approx 16$  M - as basis for the liquid
- **SUGAR-** Refined sugar in crystals, as available in food shops - to reduce relative permittivity
- **SALT-** Pure NaCl - to increase conductivity
- **CELLULOSE-** Hydroxyethyl-cellulose, medium viscosity (75-125mPa.s, 2% in water, 20\_C),  
CAS # 54290 - to increase viscosity and to keep sugar in solution
- **PRESERVATIVE-** Preventol D-7 Bayer AG, D-51368 Leverkusen, CAS # 55965-84-9 - to prevent the spread of bacteria and molds
- **DGMBE-** Diethylenglycol-monobuthyl ether (DGMBE), Fluka Chemie GmbH, CAS # 112-34-5 - to reduce relative permittivity

**THE RECIPES FOR 2450MHz SIMULATING LIQUID TABLE**

INGREDIENT	HEAD SIMULATING LIQUID 2450MHz (HSL-2450)	MUSCLE SIMULATING LIQUID 2450MHz (MSL-2450)
Water	45%	69.83%
DGMBE	55%	30.17%
Salt	NA	NA
Dielectric Parameters at 22°C	f= 2450MHz $\epsilon = 39.2 \pm 5\%$ $\sigma = 1.80 \pm 5\%$ S/m	f= 2450MHz $\epsilon = 52.7 \pm 5\%$ $\sigma = 1.95 \pm 5\%$ S/m



Testing the liquids using the Agilent Network Analyzer E8358A and Agilent Dielectric Probe Kit 85070D. The testing procedure is following as

1. Turn Network Analyzer on and allow at least 30min. warm up.
2. Mount dielectric probe kit so that interconnecting cable to Network Analyzer will not be moved during measurements or calibration.
3. Pour de-ionized water and measure water temperature ( $\pm 1^\circ$ ).
4. Set water temperature in Agilent-Software (Calibration Setup).
5. Perform calibration.
6. Validate calibration with dielectric material of known properties (e.g. polished ceramic slab with  $>8\text{mm}$  thickness  $\epsilon' = 10.0$ ,  $\epsilon'' = 0.0$ ). If measured parameters do not fit within tolerance, repeat calibration ( $\pm 0.2$  for  $\epsilon'$ :  $\pm 0.1$  for  $\epsilon''$ ).
7. Conductivity can be calculated from  $\epsilon''$  by  $\sigma = \omega \epsilon_0 \epsilon'' = \epsilon'' f [\text{GHz}] / 18$ .
8. Measure liquid shortly after calibration. Repeat calibration every hour.
9. Stir the liquid to be measured. Take a sample ( $\sim 50\text{ml}$ ) with a syringe from the center of the liquid container.
10. Pour the liquid into a small glass flask. Hold the syringe at the bottom of the flask to avoid air bubbles.
11. Put the dielectric probe in the glass flask. Check that there are no air bubbles in front of the opening in the dielectric probe kit.
12. Perform measurements.
13. Adjust medium parameters in DASY4 for the frequencies necessary for the measurements ('Setup Config', select medium (e.g. Brain 900MHz) and press 'Option'-button.
14. Select the current medium for the frequency of the validation (e.g. Setup Medium Brain 900MHz).



**FOR 2.4GHz BAND SIMULATING LIQUID**

<b>LIQUID TYPE</b>		MSL-2450		
<b>SIMULATING LIQUID TEMP.</b>		22.2		
<b>TEST DATE</b>		May 11, 2009		
<b>TESTED BY</b>		Sam Onn		
<b>FREQ. (MHz)</b>	<b>LIQUID PARAMETER</b>	<b>STANDARD VALUE</b>	<b>MEASUREMENT VALUE</b>	<b>ERROR PERCENTAGE (%)</b>
2437.0	Permittivity ( $\epsilon$ )	52.70	54.20	2.85
2450.0		52.70	54.10	2.66
2462.0		52.70	54.00	2.47
2437.0	Conductivity ( $\sigma$ ) S/m	1.94	1.96	1.03
2450.0		1.95	1.97	1.03
2462.0		1.97	2.00	1.52
<b>Dielectric Parameters Required at 22°C</b>		<b>f= 2450MHz</b> <b><math>\epsilon= 52.7 \pm 5\%</math></b> <b><math>\sigma= 1.95 \pm 5\%</math> S/m</b>		



## 5.5 TEST EQUIPMENT FOR TISSUE PROPERTY

ITEM	NAME	BRAND	TYPE	SERIES NO.	DATE OF CALIBRATION	DUE DATE OF CALIBRATION
1	Network Analyzer	Agilent	E8358A	US41480538	Nov. 27, 2008	Nov. 26, 2009
2	Dielectric Probe	Agilent	85070D	US01440176	NA	NA

**NOTE:**

1. Before starting, all test equipment shall be warmed up for 30min.
2. The tolerance ( $k=1$ ) specified by Agilent for general dielectric measurements, deriving from inaccuracies in the calibration data, analyzer drift, and random errors, are usually  $\pm 2.5\%$  and  $\pm 5\%$  for measured permittivity and conductivity, respectively. However, the tolerances for the conductivity is smaller for material with large loss tangents, i.e., less than  $\pm 2.5\%$  ( $k=1$ ). It can be substantially smaller if more accurate methods are applied.



## 6. SYSTEM VALIDATION

The system validation was performed in the flat phantom with equipment listed in the following table. Since the SAR value is calculated from the measured electric field, dielectric constant and conductivity of the body tissue and the SAR is proportional to the square of the electric field. So, the SAR value will be also proportional to the RF power input to the system validation dipole under the same test environment. In our system validation test, 250mW RF input power was used.

### 6.1 TEST EQUIPMENT

ITEM	NAME	BRAND	TYPE	SERIES NO.	DATE OF CALIBRATION	DUE DATE OF CALIBRATION
1	SAM Phantom	S & P	QD000 P40 CA	TP-1150	NA	NA
2	Signal Generator	Anritsu	68247B	984703	May 27, 2008	May 26, 2009
3	E-Field Probe	S & P	EX3DV3	3504	Jan. 21, 2009	Jan. 20, 2010
4	DAE	S & P	DAE 3	510	Jan. 21, 2009	Jan. 20, 2010
5	Robot Positioner	Staubli Unimation	NA	NA	NA	NA
6	Validation Dipole	S & P	D2450V2	716	Mar. 17, 2009	Mar. 16, 2010

**NOTE:** Before starting the measurement, all test equipment shall be warmed up for 30min.



## 6.2 TEST PROCEDURE

Before the system performance check, we need only to tell the system which components (probe, medium, and device) are used for the system performance check; the system will take care of all parameters. The dipole must be placed beneath the flat section of the SAM Twin Phantom with the correct distance holder in place. The distance holder should touch the phantom surface with a light pressure at the reference marking (little cross) and be oriented parallel to the long side of the phantom. Accurate positioning is not necessary, since the system will search for the peak SAR location, except that the dipole arms should be parallel to the surface. The device holder for mobile phones can be left in place but should be rotated away from the dipole.

1. The "Power Reference Measurement" and "Power Drift Measurement" jobs are located at the beginning and end of the batch process. They measure the field drift at one single point in the liquid over the complete procedure. The indicated drift is mainly the variation of the amplifier output power. If it is too high (above  $\pm 0.1$  dB), the system performance check should be repeated; some amplifiers have very high drift during warm-up. A stable amplifier gives drift results in the DASY system below  $\pm 0.02$  dB.
2. The "Surface Check" job tests the optical surface detection system of the DASY system by repeatedly detecting the surface with the optical and mechanical surface detector and comparing the results. The output gives the detecting heights of both systems, the difference between the two systems and the standard deviation of the detection repeatability. Air bubbles or refraction in the liquid due to separation of the sugar-water mixture gives poor repeatability (above  $\pm 0.1$  mm). In that case it is better to abort the system performance check and stir the liquid.



3. The "Area Scan" job measures the SAR above the dipole on a plane parallel to the surface. It is used to locate the approximate location of the peak SAR. The proposed scan uses large grid spacing for faster measurement; due to the symmetric field, the peak detection is reliable. If a finer graphic is desired, the grid spacing can be reduced. Grid spacing and orientation have no influence on the SAR result.
4. The "Zoom Scan" job measures the field in a volume around the peak SAR value assessed in the previous "Area Scan" job (for more information see the application note on SAR evaluation).

About the validation dipole positioning uncertainty, the constant and low loss dielectric spacer is used to establish the correct distance between the top surface of the dipole and the bottom surface of the phantom, the error component introduced by the uncertainty of the distance between the liquid (i.e., phantom shell) and the validation dipole in the DASy4 system is less than  $\pm 0.1$  mm.

$$SAR_{tolerance} [\%] = 100 \times \left( \frac{(a + d)^2}{a^2} - 1 \right)$$

As the closest distance is 10 mm, the resulting tolerance  $SAR_{tolerance} [\%]$  is <2%.



### 6.3 VALIDATION RESULTS

SYSTEM VALIDATION TEST OF SIMULATING LIQUID					
FREQUENCY (MHz)	REQUIRED SAR (mW/g)	MEASURED SAR (mW/g)	DEVIATION (%)	SEPARATION DISTANCE	TESTED DATE
MSL2450	13.30 (1g)	13.30	0	10mm	May 11, 2009
TESTED BY	Sam Onn				

**NOTE:** Please see Appendix for the photo of system validation test.



## 6.4 SYSTEM VALIDATION UNCERTAINTIES

In the table below, the system validation uncertainty with respect to the analytically assessed SAR value of a dipole source as given in the IEEE 1528 standard is given. This uncertainty is smaller than the expected uncertainty for mobile phone measurements due to the simplified setup and the symmetric field distribution.

Error Description	Tolerance (±%)	Probability Distribution	Divisor	(C <sub>i</sub> )		Standard Uncertainty (±%)		(v <sub>i</sub> )
				(1g)	(10g)	(1g)	(10g)	
<b>Measurement System</b>								
Probe Calibration	5.50	Normal	1	1	1	5.50	5.50	∞
Axial Isotropy	4.70	Rectangular	$\sqrt{3}$	0.7	0.7	1.90	1.90	∞
Hemispherical Isotropy	9.60	Rectangular	$\sqrt{3}$	0.7	0.7	3.88	3.88	∞
Boundary effects	1.00	Rectangular	$\sqrt{3}$	1	1	0.58	0.58	∞
Linearity	4.70	Rectangular	$\sqrt{3}$	1	1	2.71	2.71	∞
System Detection Limits	1.00	Rectangular	$\sqrt{3}$	1	1	0.58	0.58	∞
Readout Electronics	0.30	Normal	1	1	1	0.30	0.30	∞
Response Time	0.80	Rectangular	$\sqrt{3}$	1	1	0.46	0.46	∞
Integration Time	2.60	Rectangular	$\sqrt{3}$	1	1	1.50	1.50	∞
RF Ambient Noise	3.00	Rectangular	$\sqrt{3}$	1	1	1.73	1.73	∞
RF Ambient Reflections	3.00	Rectangular	$\sqrt{3}$	1	1	1.73	1.73	∞
Probe Positioner	0.40	Rectangular	$\sqrt{3}$	1	1	0.23	0.23	∞
Probe Positioning	2.90	Rectangular	$\sqrt{3}$	1	1	1.67	1.67	∞
Max. SAR Eval.	1.00	Rectangular	$\sqrt{3}$	1	1	0.58	0.58	∞
<b>Dipole Related</b>								
Dipole Axis to Liquid Distance	2.00	Rectangular	$\sqrt{3}$	1	1	1.15	1.15	145
Input Power Drift	5.00	Rectangular	$\sqrt{3}$	1	1	2.89	2.89	∞
<b>Phantom and Tissue parameters</b>								
Phantom Uncertainty	4.00	Rectangular	$\sqrt{3}$	1	1	2.31	2.31	∞
Liquid Conductivity (target)	5.00	Rectangular	$\sqrt{3}$	0.64	0.43	1.85	1.24	∞
Liquid Conductivity (measurement)	2.53	Normal	1	0.64	0.43	1.62	1.09	∞
Liquid Permittivity (target)	5.00	Rectangular	$\sqrt{3}$	0.6	0.49	1.73	1.41	∞
Liquid Permittivity (measurement)	3.49	Normal	1	0.6	0.49	2.09	1.71	∞
<b>Combined Standard Uncertainty</b>						<b>9.85</b>	<b>9.56</b>	
<b>Coverage Factor for 95%</b>						<b>Kp=2</b>		
<b>Expanded Uncertainty (K=2)</b>						<b>19.71</b>	<b>19.11</b>	

**NOTE:** About the system validation uncertainty assessment, please reference the section 7.

## 7. MEASUREMENT SAR PROCEDURE UNCERTAINTIES

The assessment of spatial peak SAR of the hand held devices is according to IEEE 1528 / EN 62209-1. All testing situation shall be met below these requirements.

- The system is used by an experienced engineer who follows the manual and the guidelines taught during the training provided by SPEAG.
- The probe has been calibrated within the requested period and the stated uncertainty for the relevant frequency bands does not exceed 4.8% ( $k=1$ ).
- The validation dipole has been calibrated within the requested period and the system performance check has been successful.
- The DAE unit has been calibrated within the within the requested period.
- The minimum distance between the probe sensor and inner phantom shell is selected to be between 4 and 5mm.
- The operational mode of the DUT is CW, CDMA, FDMA or TDMA (GSM, DCS, PCS, IS136 and PDC) and the measurement/integration time per point is >500 ms.
- The dielectric parameters of the liquid have been assessed using Agilent 85070D dielectric probe kit or a more accurate method.
- The dielectric parameters are within 5% of the target values.
- The DUT has been positioned as described in section 3.

### 7.1. PROBE CALIBRATION UNCERTAINTY

SPEAG conducts the probe calibration in compliance with international and national standards (e.g. IEEE 1528, EN 62209-1, IEC 62209, etc.) under ISO17025. The uncertainties are stated on the calibration certificate. For the most relevant frequency bands, these values do not exceed 4.8% ( $k=1$ ). If evaluations of other bands are performed for which the uncertainty exceeds these values, the uncertainty tables given in the summary have to be revised accordingly.

## 7.2. ISOTROPY UNCERTAINTY

The axial isotropy tolerance accounts for probe rotation around its axis while the hemispherical isotropy error includes all probe orientations and field polarizations. These parameters are assessed by SPEAG during initial calibration. In 2001, SPEAG further tightened its quality controls and warrants that the maximal deviation from axial isotropy is  $\pm 0.20\text{dB}$ , while the maximum deviation of hemispherical isotropy is  $\pm 0.40\text{dB}$ , corresponding to  $\pm 4.7\%$  and  $\pm 9.6\%$ , respectively. A weighting factor of  $c_p$  equal to 0.5 can be applied, since the axis of the probe deviates less than 30 degrees from the normal surface orientation.

## 7.3. BOUNDARY EFFECT UNCERTAINTY

The effect can be estimated according to the following error approximation formula

$$SAR_{tolerance} [\%] = SAR_{be} [\%] \times \frac{(d_{be} + d_{step})^2}{2d_{step}} e^{\frac{d_{be}}{\delta/2}}$$

$$d_{be} + d_{step} < 10\text{mm}$$

The parameter  $d_{be}$  is the distance in mm between the surface and the closest measurement point used in the averaging process;  $d_{step}$  is the separation distance in mm between the first and second measurement points;  $\delta$  is the minimum penetration depth in mm within the head tissue equivalent liquids (i.e.,  $\delta = 13.95\text{mm}$  at 3GHz);  $SAR_{be}$  is the deviation between the measured SAR value at the distance  $d_{be}$  from the boundary and the wave-guide analytical value  $SAR_{ref}$ . DASY4 applies a boundary effect compensation algorithm according to IEEE 1528, which is possible since the axis of the probe never deviates more than 30 degrees from the normal surface orientation.  $SAR_{be} [\%]$  is assessed during the calibration process and SPEAG warrants that the uncertainty at distances larger than 4mm is always less than 1%. In summary, the worst case boundary effect SAR tolerance [%] for scanning distances larger than 4mm is  $< \pm 0.8\%$ .

#### 7.4. PROBE LINEARITY UNCERTAINTY

Field probe linearity uncertainty includes errors from the assessment and compensation of the diode compression effects for CW and pulsed signals with known duty cycles. This error is assessed using the procedure described in IEEE 1528 / EN 62209-1. For SPEAG field probes, the measured difference between CW and pulsed signals, with pulse frequencies between 10Hz and 1kHz and duty cycles between 1 and 100, is  $< \pm 0.20\text{dB}$  ( $< \pm 4.7\%$ ).

#### 7.5. READOUT ELECTRONICS UNCERTAINTY

All uncertainties related to the probe readout electronics (DAE unit), including the gain and linearity of the instrumentation amplifier, its loading effect on the probe, and accuracy of the signal conversion algorithm, have been assessed accordingly to IEEE 1528 / EN 62209-1. The combination (root-sum-square RSS method) of these components results in an overall maximum error of  $\pm 1.0\%$ .

#### 7.6. RESPONSE TIME UNCERTAINTY

The time response of the field probes is assessed by exposing the probe to a well-controlled electric field producing SAR larger than  $2.0\text{W/kg}$  at the tissue medium surface. The signal response time is evaluated as the time required by the system to reach 90% of the expected final value after an on/of switch of the power source. Analytically, it can be expressed as:

$$SAR_{tolerance} [\%] = 100 \times \left( \frac{T_m}{T_m + \tau e^{-T_m/\tau} - \tau} - 1 \right)$$

where  $T_m$  is 500 ms, i.e., the time between measurement samples, and  $\tau$  the time constant. The response time  $\tau$  of SPEAG's probes is  $< 5\text{ms}$ . In the current implementation, DASY4 waits longer than 100 ms after having reached the grid point before starting a measurement, i.e., the response time uncertainty is negligible.

## 7.7. INTEGRATION TIME UNCERTAINTY

If the device under test does not emit a CW signal, the integration time applied to measure the electric field at a specific point may introduce additional uncertainties due to the discretization and can be assessed as follows

$$SAR_{tolerance} [\%] = 100 \times \sum_{all\ sub-frames} \frac{t_{frame}}{t_{integration}} \frac{slot_{idle}}{slot_{total}}$$

The tolerances for the different systems are given in Table 7.1, whereby the worst-case  $SAR_{tolerance}$  is 2.6%.

System	$SAR_{tolerance}$ %
CW	0
CDMA*	0
WCDMA*	0
FDMA	0
IS-136	2.6
PDC	2.6
GSM/DCS/PCS	1.7
DECT	1.9
Worst-Case	2.6

**TABLE 7.1**

## 7.8. PROBE POSITIONER MECHANICAL TOLERANCE

The mechanical tolerance of the field probe positioner can introduce probe positioning uncertainties. The resulting SAR uncertainty is assessed by comparing the SAR obtained according to the specifications of the probe positioner with respect to the actual position defined by the geometric center of the probe sensors. The tolerance is determined as:

$$SAR_{tolerance} [\%] = 100 \times \frac{d_{ph}}{\delta/2}$$

The specified repeatability of the RX robot family used in DASY4 systems is  $\pm 25\mu\text{m}$ . The absolute accuracy for short distance movements is better than  $\pm 0.1\text{mm}$ , i.e., the  $SAR_{tolerance}[\%]$  is better than 1.5% (rectangular).

## 7.9. PROBE POSITIONING

The probe positioning procedures affect the tolerance of the separation distance between the probe tip and the phantom surface as:

$$SAR_{tolerance} [\%] = 100 \times \frac{d_{ph}}{\delta/2}$$

where  $d_{ph}$  is the maximum deviation of the distance between the probe tip and the phantom surface. The optical surface detection has a precision of better than 0.2mm, resulting in an  $SAR_{tolerance}[\%]$  of <2.9% (rectangular distribution). Since the mechanical detection provides better accuracy, 2.9% is a worst-case figure for DASY4 system.

## 7.10. PHANTOM UNCERTAINTY

The SAR measurement uncertainty due to SPEAG phantom shell production tolerances has been evaluated using

$$SAR_{tolerance} [\%] \cong 100 \times \frac{2d}{a}, \quad d \ll a$$

For a maximum deviation  $d$  of the inner and outer shell of the phantom from that specified in the CAD file of  $\pm 0.2\text{mm}$ , and a  $10\text{mm}$  spacing  $a$  between source and tissue liquid, the calculated phantom uncertainty is  $\pm 4.0\%$ .

## 7.11. DASY4 UNCERTAINTY BUDGET

Error Description	Tolerance (±%)	Probability Distribution	Divisor	(C <sub>i</sub> )		Standard Uncertainty (±%)		(v <sub>i</sub> )
				(1g)	(10g)	(1g)	(10g)	
<b>Measurement System</b>								
Probe Calibration	5.50	Normal	1	1	1	5.50	5.50	∞
Axial Isotropy	4.70	Rectangular	√3	0.7	0.7	1.90	1.90	∞
Hemispherical Isotropy	9.60	Rectangular	√3	0.7	0.7	3.88	3.88	∞
Boundary effects	1.00	Rectangular	√3	1	1	0.58	0.58	∞
Linearity	4.70	Rectangular	√3	1	1	2.71	2.71	∞
System Detection Limits	1.00	Rectangular	√3	1	1	0.58	0.58	∞
Readout Electronics	0.30	Normal	1	1	1	0.30	0.30	∞
Response Time	0.80	Rectangular	√3	1	1	0.46	0.46	∞
Integration Time	2.60	Rectangular	√3	1	1	1.50	1.50	∞
RF Ambient Noise	3.00	Rectangular	√3	1	1	1.73	1.73	∞
RF Ambient Reflections	3.00	Rectangular	√3	1	1	1.73	1.73	∞
Probe Positioner	0.40	Rectangular	√3	1	1	0.23	0.23	∞
Probe Positioning	2.90	Rectangular	√3	1	1	1.67	1.67	∞
Max. SAR Eval.	1.00	Rectangular	√3	1	1	0.58	0.58	∞
<b>Test Sample Related</b>								
Device Positioning	0.69	Normal	1	1	1	0.69	0.69	10
Device Holder	3.60	Normal	1	1	1	3.60	3.60	5
Power Drift	5.00	Rectangular	√3	1	1	2.89	2.89	∞
<b>Phantom and Tissue parameters</b>								
Phantom Uncertainty	4.00	Rectangular	√3	1	1	2.31	2.31	∞
Liquid Conductivity (target)	5.00	Rectangular	√3	0.64	0.43	1.85	1.24	∞
Liquid Conductivity (measurement)	2.53	Normal	1	0.64	0.43	1.62	1.09	∞
Liquid Permittivity (target)	5.00	Rectangular	√3	0.6	0.49	1.73	1.41	∞
Liquid Permittivity (measurement)	3.49	Normal	1	0.6	0.49	2.09	1.71	∞
<b>Combined Standard Uncertainty</b>						<b>10.45</b>	<b>10.17</b>	
<b>Coverage Factor for 95%</b>						<b>Kp=2</b>		
<b>Expanded Uncertainty (K=2)</b>						<b>20.90</b>	<b>20.34</b>	

**TABLE 7.2**

The table 7.2: Worst-Case uncertainty budget for DASY4 assessed according to IEEE 1528. The budget is valid for the frequency range 300MHz ~ 3GHz and represents a worst-case analysis. For specific tests and configurations, the uncertainty could be considerable smaller.





## 8. INFORMATION ON THE TESTING LABORATORIES

We, Bureau Veritas Consumer Products Services (H.K.) Ltd., Taoyuan Branch, were founded in 1988 to provide our best service in EMC, Radio, Telecom and Safety consultation. Our laboratories are accredited and approved by the following approval agencies according to ISO/IEC 17025.

<b>USA</b>	FCC, NVLAP
<b>GERMANY</b>	TUV Rheinland
<b>JAPAN</b>	VCCI
<b>NORWAY</b>	NEMKO
<b>CANADA</b>	INDUSTRY CANADA, CSA
<b>R.O.C.</b>	TAF, BSMI, NCC
<b>NETHERLANDS</b>	Telefication
<b>SINGAPORE</b>	GOST-ASIA (MOU)
<b>RUSSIA</b>	CERTIS (MOU)

Copies of accreditation certificates of our laboratories obtained from approval agencies can be downloaded from our web site: [www.adt.com.tw/index.5/phtml](http://www.adt.com.tw/index.5/phtml). If you have any comments, please feel free to contact us at the following:

**Linko EMC/RF Lab:**  
Tel: 886-2-26052180  
Fax: 886-2-26051924

**Hsin Chu EMC/RF Lab:**  
Tel: 886-3-5935343  
Fax: 886-3-5935342

**Hwa Ya EMC/RF/Safety/Telecom Lab:**  
Tel: 886-3-3183232  
Fax: 886-3-3185050

**Web Site:** [www.adt.com.tw](http://www.adt.com.tw)

The address and road map of all our labs can be found in our web site also.

---END---

## APPENDIX A: TEST DATA

### Liquid Level Photo

MSL 2450MHz D=150mm



Test Laboratory: Bureau Veritas ADT

**M01-11b-Ch11****DUT: Wireless N USB Adapter ; Type: DWA-130E1**

Communication System: 802.11b ; Frequency: 2462 MHz ; Duty Cycle: 1:1 ; Modulation type: DBPSK  
Medium: MSL2450 Medium parameters used:  $f = 2462$  MHz;  $\sigma = 2$  mho/m;  $\epsilon_r = 54$ ;  $\rho = 1000$  kg/m<sup>3</sup>  
Phantom section: Flat Section ; Separation distance : 5 mm (The bottom side of the EUT to the Phantom)

DASY4 Configuration:

- Probe: EX3DV3 - SN3504 ; ConvF(7.53, 7.53, 7.53) ; Calibrated: 2009/1/21
- Sensor-Surface: 3mm (Mechanical Surface Detection)
- Electronics: DAE3 Sn510 ; Calibrated: 2009/1/21
- Phantom: SAM 12 ; Type: SAM V4.0 ; Serial: TP 1202
- Measurement SW: DASY4, V4.7 Build 80 ; Postprocessing SW: SEMCAD, V1.8 Build 186

**High Channel 11/Area Scan (5x7x1):** Measurement grid: dx=15mm, dy=15mm

Maximum value of SAR (measured) = 0.942 mW/g

**High Channel 11/Zoom Scan (7x7x7) (7x7x7)/Cube 0:** Measurement grid: dx=5mm, dy=5mm, dz=5mm

Reference Value = 13.8 V/m

Peak SAR (extrapolated) = 1.43 W/kg

**SAR(1 g) = 0.689 mW/g; SAR(10 g) = 0.374 mW/g**

Maximum value of SAR (measured) = 0.869 mW/g

**High Channel 11/Zoom Scan (7x7x7) (7x7x7)/Cube 1:** Measurement grid: dx=5mm, dy=5mm, dz=5mm

Reference Value = 13.8 V/m

Peak SAR (extrapolated) = 1.25 W/kg

**SAR(1 g) = 0.659 mW/g; SAR(10 g) = 0.329 mW/g**

Maximum value of SAR (measured) = 0.850 mW/g

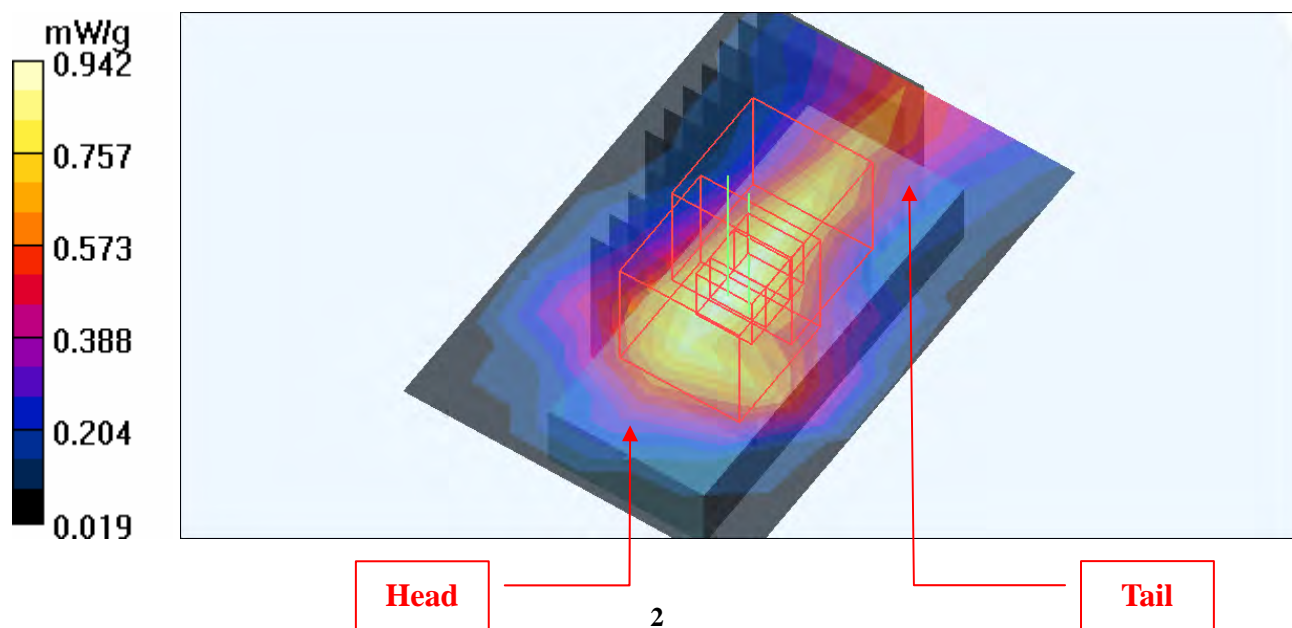

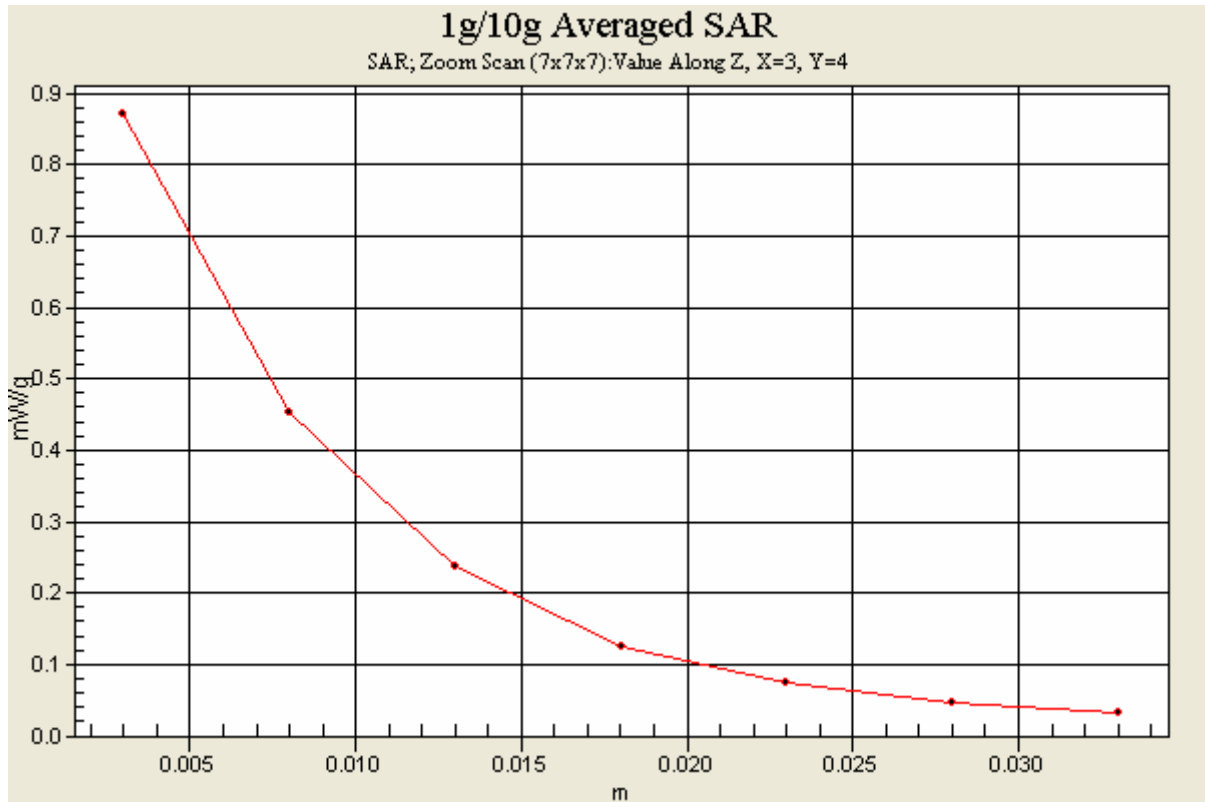

Test Laboratory: Bureau Veritas ADT

## M02-11b-Ch11 w/o EPROM

**DUT: Wireless N USB Adapter ; Type: DWA-130E1**

Communication System: 802.11b ; Frequency: 2462 MHz ; Duty Cycle: 1:1 ; Modulation type: DBPSK

Medium: MSL2450 Medium parameters used:  $f = 2462$  MHz;  $\sigma = 2$  mho/m;  $\epsilon_r = 54$ ;  $\rho = 1000$  kg/m<sup>3</sup>

Phantom section: Flat Section ; Separation distance : 5 mm (The bottom side of the EUT to the Phantom)

DASY4 Configuration:

- Probe: EX3DV3 - SN3504 ; ConvF(7.53, 7.53, 7.53) ; Calibrated: 2009/1/21
- Sensor-Surface: 3mm (Mechanical Surface Detection)
- Electronics: DAE3 Sn510 ; Calibrated: 2009/1/21
- Phantom: SAM 12 ; Type: SAM V4.0 ; Serial: TP 1202
- Measurement SW: DASY4, V4.7 Build 80 ; Postprocessing SW: SEMCAD, V1.8 Build 186

**High Channel 11/Area Scan (5x7x1):** Measurement grid: dx=15mm, dy=15mm

Maximum value of SAR (measured) = 0.761 mW/g

**High Channel 11/Zoom Scan (7x7x7) (7x7x7)/Cube 0:** Measurement grid: dx=5mm, dy=5mm, dz=5mm

Reference Value = 13.1 V/m

Peak SAR (extrapolated) = 1.15 W/kg

**SAR(1 g) = 0.608 mW/g; SAR(10 g) = 0.333 mW/g**

Maximum value of SAR (measured) = 0.757 mW/g

**High Channel 11/Zoom Scan (7x7x7) (7x7x7)/Cube 1:** Measurement grid: dx=5mm, dy=5mm, dz=5mm

Reference Value = 13.1 V/m

Peak SAR (extrapolated) = 1.02 W/kg

**SAR(1 g) = 0.596 mW/g; SAR(10 g) = 0.301 mW/g**

Maximum value of SAR (measured) = 0.728 mW/g

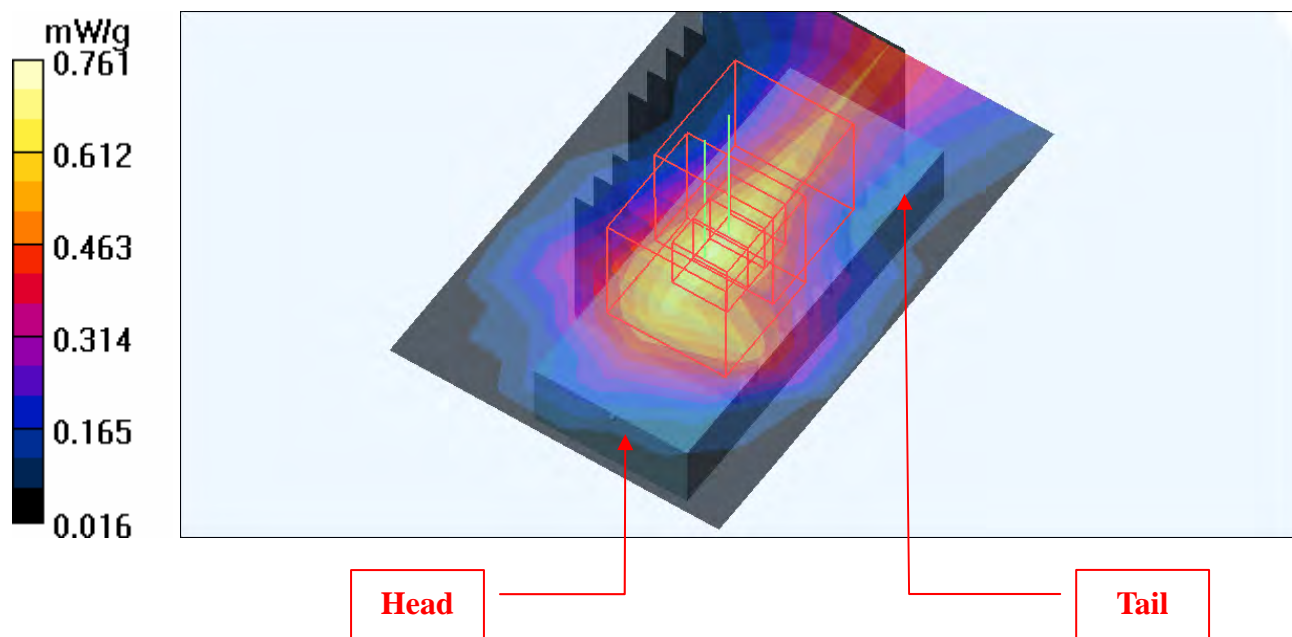

Test Laboratory: Bureau Veritas ADT

**M03-11g-Ch6****DUT: Wireless N USB Adapter ; Type: DWA-130E1**

Communication System: 802.11g ; Frequency: 2437 MHz ; Duty Cycle: 1:1 ; Modulation type: BPSK  
Medium: MSL2450 Medium parameters used:  $f = 2437$  MHz;  $\sigma = 1.96$  mho/m;  $\epsilon_r = 54.2$ ;  $\rho = 1000$  kg/m<sup>3</sup>  
Phantom section: Flat Section ; Separation distance : 5 mm (The bottom side of the EUT to the Phantom)

DASY4 Configuration:

- Probe: EX3DV3 - SN3504 ; ConvF(7.53, 7.53, 7.53) ; Calibrated: 2009/1/21
- Sensor-Surface: 3mm (Mechanical Surface Detection)
- Electronics: DAE3 Sn510 ; Calibrated: 2009/1/21
- Phantom: SAM 12 ; Type: SAM V4.0 ; Serial: TP 1202
- Measurement SW: DASY4, V4.7 Build 80 ; Postprocessing SW: SEMCAD, V1.8 Build 186

**Mid Channel 6/Area Scan (5x7x1):** Measurement grid: dx=15mm, dy=15mm

Maximum value of SAR (measured) = 0.522 mW/g

**Mid Channel 6/Zoom Scan (7x7x7) (7x7x7)/Cube 0:** Measurement grid: dx=5mm, dy=5mm, dz=5mm

Reference Value = 10.7 V/m

Peak SAR (extrapolated) = 0.967 W/kg

**SAR(1 g) = 0.436 mW/g; SAR(10 g) = 0.244 mW/g**

Maximum value of SAR (measured) = 0.571 mW/g

**Mid Channel 6/Zoom Scan (7x7x7) (7x7x7)/Cube 1:** Measurement grid: dx=5mm, dy=5mm, dz=5mm

Reference Value = 10.7 V/m

Peak SAR (extrapolated) = 0.812 W/kg

**SAR(1 g) = 0.421 mW/g; SAR(10 g) = 0.210 mW/g**

Maximum value of SAR (measured) = 0.551 mW/g

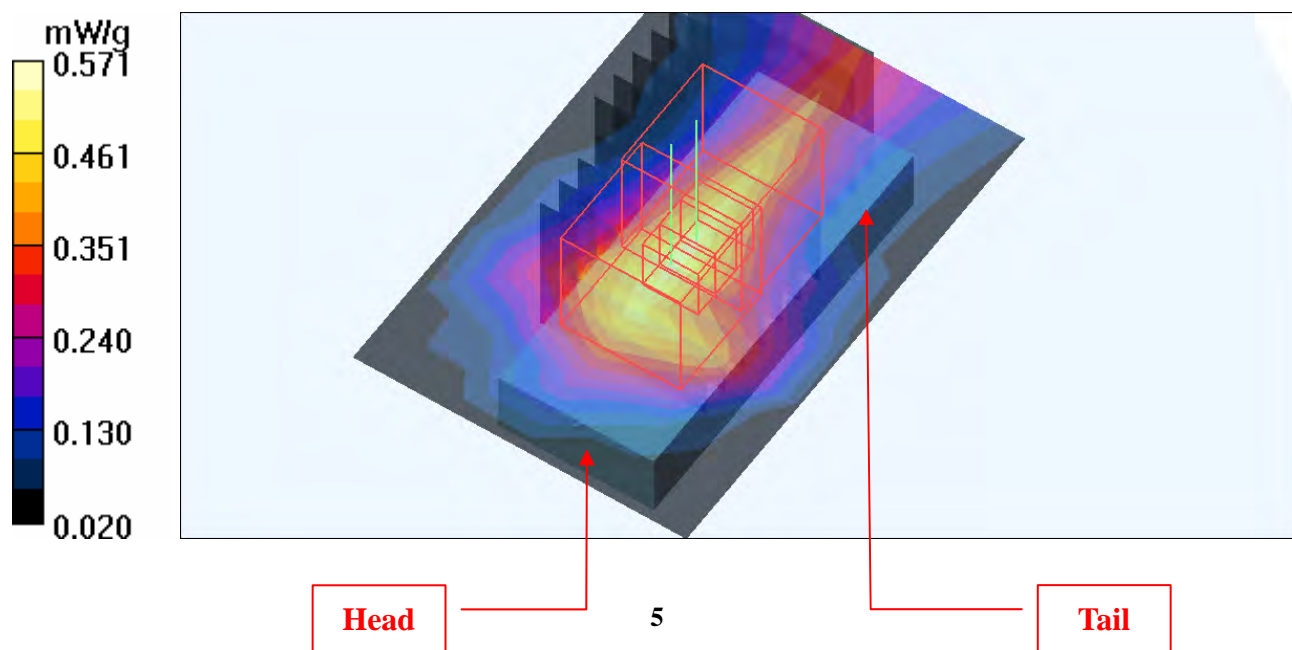

Test Laboratory: Bureau Veritas ADT

**M04-11N 20M-Ch6****DUT: Wireless N USB Adapter ; Type: DWA-130E1**

Communication System: 2.4G 11n span20 ; Frequency: 2437 MHz ; Duty Cycle: 1:1 ; Modulation type: BPSK

Medium: MSL2450 Medium parameters used:  $f = 2437$  MHz;  $\sigma = 1.96$  mho/m;  $\epsilon_r = 54.2$ ;  $\rho = 1000$  kg/m<sup>3</sup>  
Phantom section: Flat Section ; Separation distance : 5 mm (The bottom side of the EUT to the Phantom)

DASY4 Configuration:

- Probe: EX3DV3 - SN3504 ; ConvF(7.53, 7.53, 7.53) ; Calibrated: 2009/1/21
- Sensor-Surface: 3mm (Mechanical Surface Detection)
- Electronics: DAE3 Sn510 ; Calibrated: 2009/1/21
- Phantom: SAM 12 ; Type: SAM V4.0 ; Serial: TP 1202
- Measurement SW: DASY4, V4.7 Build 80 ; Postprocessing SW: SEMCAD, V1.8 Build 186

**Mid Channel 6/Area Scan (5x7x1):** Measurement grid: dx=15mm, dy=15mm

Maximum value of SAR (measured) = 0.530 mW/g

**Mid Channel 6/Zoom Scan (7x7x7) (7x7x7)/Cube 0:** Measurement grid: dx=5mm, dy=5mm, dz=5mm

Reference Value = 11.3 V/m

Peak SAR (extrapolated) = 0.957 W/kg

**SAR(1 g) = 0.436 mW/g; SAR(10 g) = 0.241 mW/g**

Maximum value of SAR (measured) = 0.559 mW/g

**Mid Channel 6/Zoom Scan (7x7x7) (7x7x7)/Cube 1:** Measurement grid: dx=5mm, dy=5mm, dz=5mm

Reference Value = 11.3 V/m

Peak SAR (extrapolated) = 0.784 W/kg

**SAR(1 g) = 0.417 mW/g; SAR(10 g) = 0.208 mW/g**

Maximum value of SAR (measured) = 0.543 mW/g

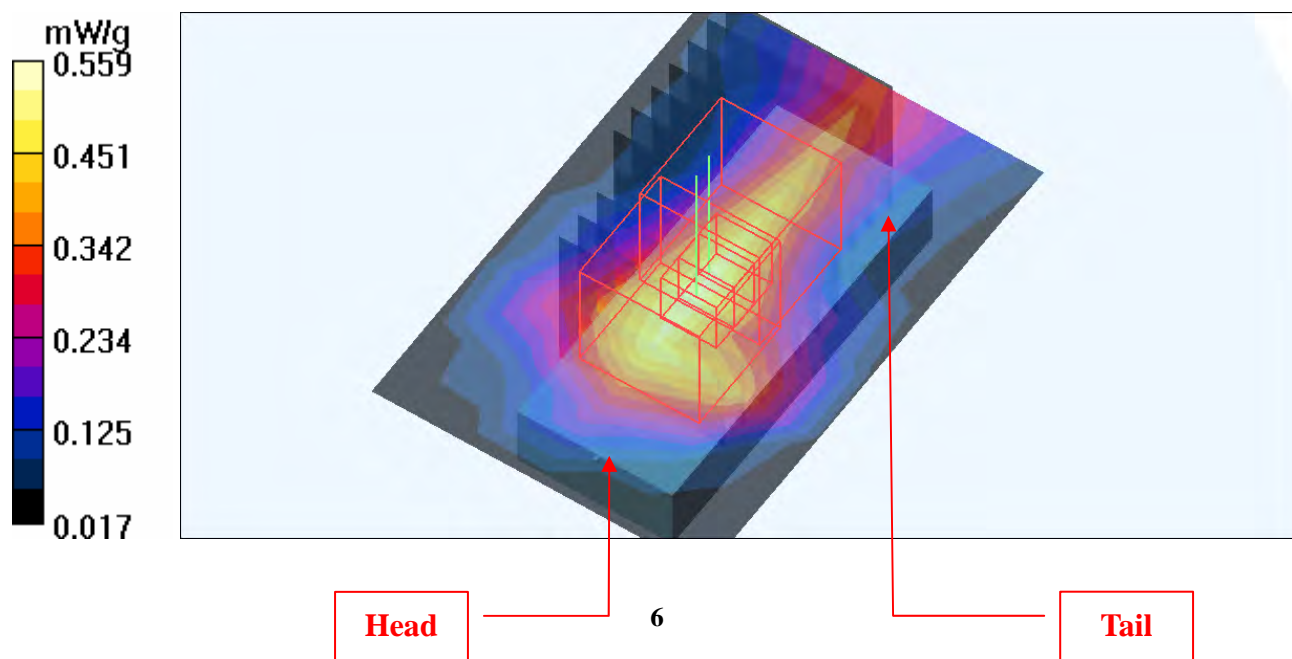

Test Laboratory: Bureau Veritas ADT

**M05-11N 40M-Ch4****DUT: Wireless N USB Adapter ; Type: DWA-130E1**

Communication System: 802.11n 40MHz ; Frequency: 2437 MHz ; Duty Cycle: 1:1 ; Modulation type: BPSK

Medium: MSL2450 Medium parameters used:  $f = 2437$  MHz;  $\sigma = 1.96$  mho/m;  $\epsilon_r = 54.2$ ;  $\rho = 1000$  kg/m<sup>3</sup>  
Phantom section: Flat Section ; Separation distance : 5 mm (The bottom side of the EUT to the Phantom)

DASY4 Configuration:

- Probe: EX3DV3 - SN3504 ; ConvF(7.53, 7.53, 7.53) ; Calibrated: 2009/1/21
- Sensor-Surface: 3mm (Mechanical Surface Detection)
- Electronics: DAE3 Sn510 ; Calibrated: 2009/1/21
- Phantom: SAM 12 ; Type: SAM V4.0 ; Serial: TP 1202
- Measurement SW: DASY4, V4.7 Build 80 ; Postprocessing SW: SEMCAD, V1.8 Build 186

**Mid Channel 4/Area Scan (5x7x1):** Measurement grid: dx=15mm, dy=15mm

Maximum value of SAR (measured) = 0.437 mW/g

**Mid Channel 4/Zoom Scan (7x7x7) (7x7x7)/Cube 0:** Measurement grid: dx=5mm, dy=5mm, dz=5mm

Reference Value = 10.6 V/m

Peak SAR (extrapolated) = 0.749 W/kg

**SAR(1 g) = 0.333 mW/g; SAR(10 g) = 0.189 mW/g**

Maximum value of SAR (measured) = 0.434 mW/g

**Mid Channel 4/Zoom Scan (7x7x7) (7x7x7)/Cube 1:** Measurement grid: dx=5mm, dy=5mm, dz=5mm

Reference Value = 10.6 V/m

Peak SAR (extrapolated) = 0.595 W/kg

**SAR(1 g) = 0.321 mW/g; SAR(10 g) = 0.163 mW/g**

Maximum value of SAR (measured) = 0.410 mW/g

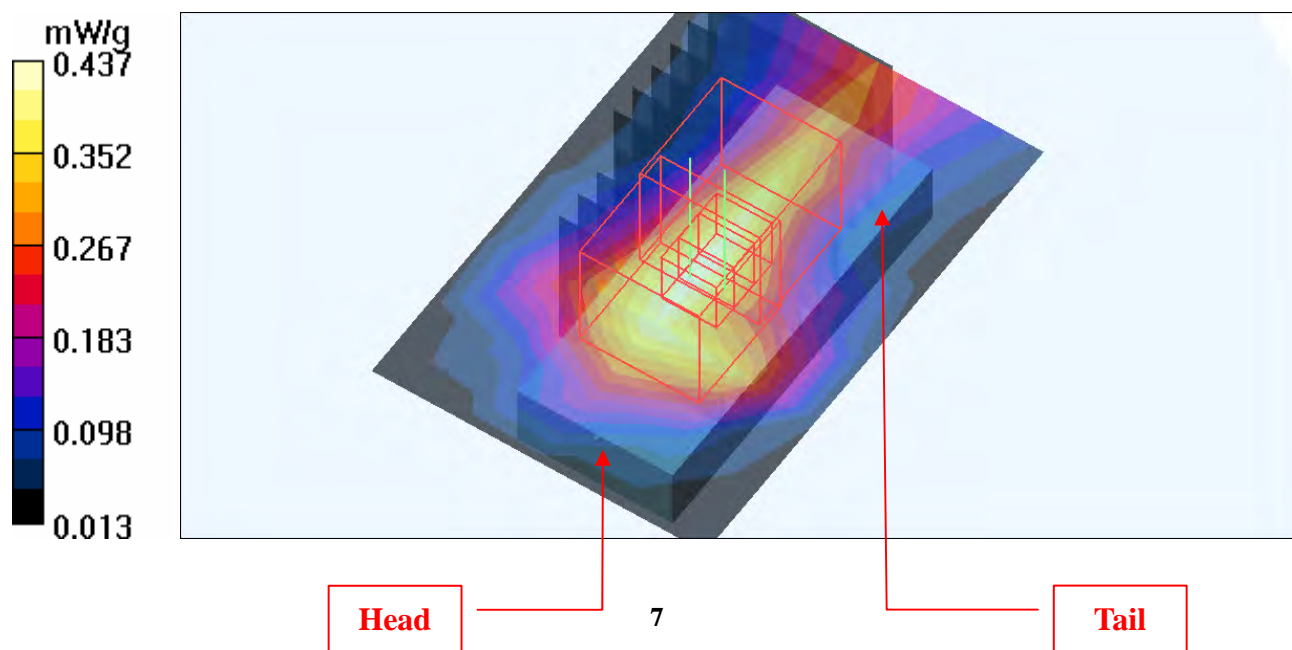



Test Laboratory: Bureau Veritas ADT

**M06-11b-Ch11****DUT: Wireless N USB Adapter ; Type: DWA-130E1**

Communication System: 802.11b ; Frequency: 2462 MHz ; Duty Cycle: 1:1 ; Modulation type: DBPSK

Medium: MSL2450 Medium parameters used:  $f = 2462$  MHz;  $\sigma = 2$  mho/m;  $\epsilon_r = 54$ ;  $\rho = 1000$  kg/m<sup>3</sup>

Phantom section: Flat Section ; Separation distance : 5 mm (The edge side of the EUT to the Phantom)

DASY4 Configuration:

- Probe: EX3DV3 - SN3504 ; ConvF(7.53, 7.53, 7.53) ; Calibrated: 2009/1/21
- Sensor-Surface: 3mm (Mechanical Surface Detection)
- Electronics: DAE3 Sn510 ; Calibrated: 2009/1/21
- Phantom: SAM 12 ; Type: SAM V4.0 ; Serial: TP 1202
- Measurement SW: DASY4, V4.7 Build 80 ; Postprocessing SW: SEMCAD, V1.8 Build 186

**High Channel 11/Area Scan (5x7x1):** Measurement grid: dx=15mm, dy=15mm

Maximum value of SAR (measured) = 0.783 mW/g

**High Channel 11/Zoom Scan (7x7x7) (7x7x7)/Cube 0:** Measurement grid: dx=5mm, dy=5mm, dz=5mm

Reference Value = 10.5 V/m

Peak SAR (extrapolated) = 1.33 W/kg

**SAR(1 g) = 0.649 mW/g; SAR(10 g) = 0.291 mW/g**

Maximum value of SAR (measured) = 0.876 mW/g

**High Channel 11/Zoom Scan (7x7x7) (7x7x7)/Cube 1:** Measurement grid: dx=5mm, dy=5mm, dz=5mm

Reference Value = 10.5 V/m

Peak SAR (extrapolated) = 0.853 W/kg

**SAR(1 g) = 0.476 mW/g; SAR(10 g) = 0.228 mW/g**

Maximum value of SAR (measured) = 0.575 mW/g

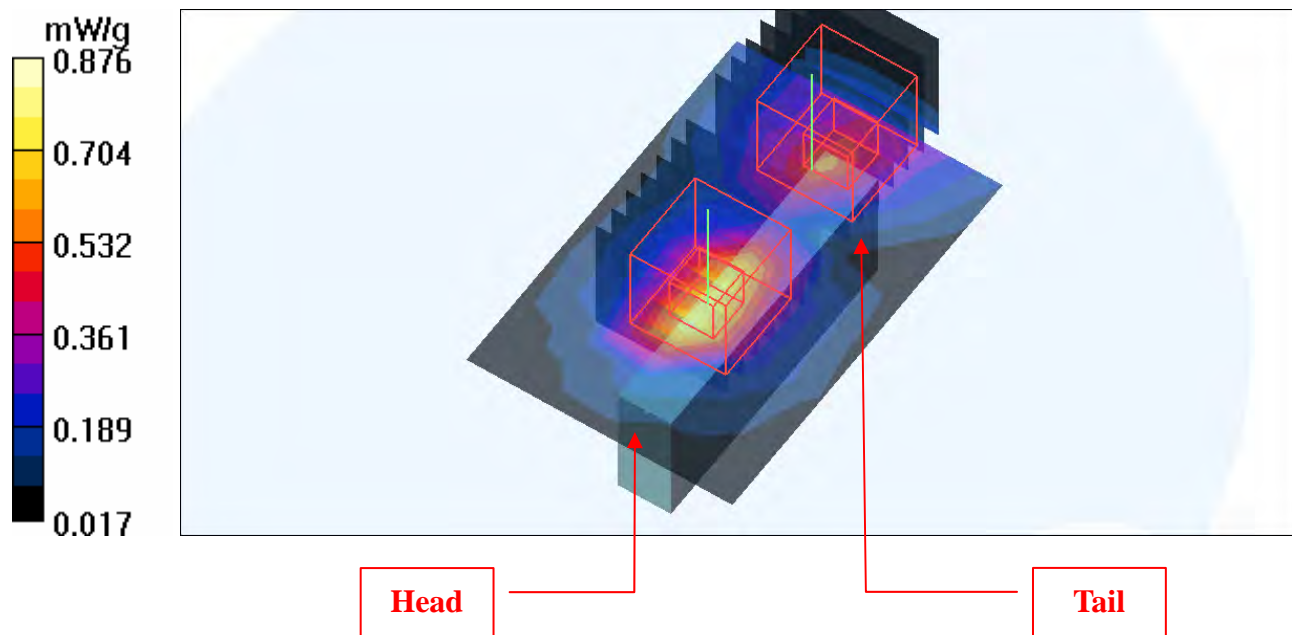

Test Laboratory: Bureau Veritas ADT

**M07-11b-Ch11 w/o EPROM****DUT: Wireless N USB Adapter ; Type: DWA-130E1**

Communication System: 802.11b ; Frequency: 2462 MHz ; Duty Cycle: 1:1 ; Modulation type: BPSK

Medium: MSL2450 Medium parameters used:  $f = 2462$  MHz;  $\sigma = 2$  mho/m;  $\epsilon_r = 54$ ;  $\rho = 1000$  kg/m<sup>3</sup>

Phantom section: Flat Section ; Separation distance : 5 mm (The edge side of the EUT to the Phantom)

DASY4 Configuration:

- Probe: EX3DV3 - SN3504 ; ConvF(7.53, 7.53, 7.53) ; Calibrated: 2009/1/21

- Sensor-Surface: 3mm (Mechanical Surface Detection)

- Electronics: DAE3 Sn510 ; Calibrated: 2009/1/21

- Phantom: SAM 12 ; Type: SAM V4.0 ; Serial: TP 1202

- Measurement SW: DASY4, V4.7 Build 80 ; Postprocessing SW: SEMCAD, V1.8 Build 186

**High Channel 11/Area Scan (5x7x1):** Measurement grid: dx=15mm, dy=15mm

Maximum value of SAR (measured) = 0.915 mW/g

**High Channel 11/Zoom Scan (7x7x7) (7x7x7)/Cube 0:** Measurement grid: dx=5mm, dy=5mm, dz=5mm

Reference Value = 11.2 V/m

Peak SAR (extrapolated) = 1.20 W/kg

**SAR(1 g) = 0.591 mW/g; SAR(10 g) = 0.266 mW/g**

Maximum value of SAR (measured) = 0.792 mW/g

**High Channel 11/Zoom Scan (7x7x7) (7x7x7)/Cube 1:** Measurement grid: dx=5mm, dy=5mm, dz=5mm

Reference Value = 11.2 V/m

Peak SAR (extrapolated) = 0.812 W/kg

**SAR(1 g) = 0.426 mW/g; SAR(10 g) = 0.214 mW/g**

Maximum value of SAR (measured) = 0.539 mW/g

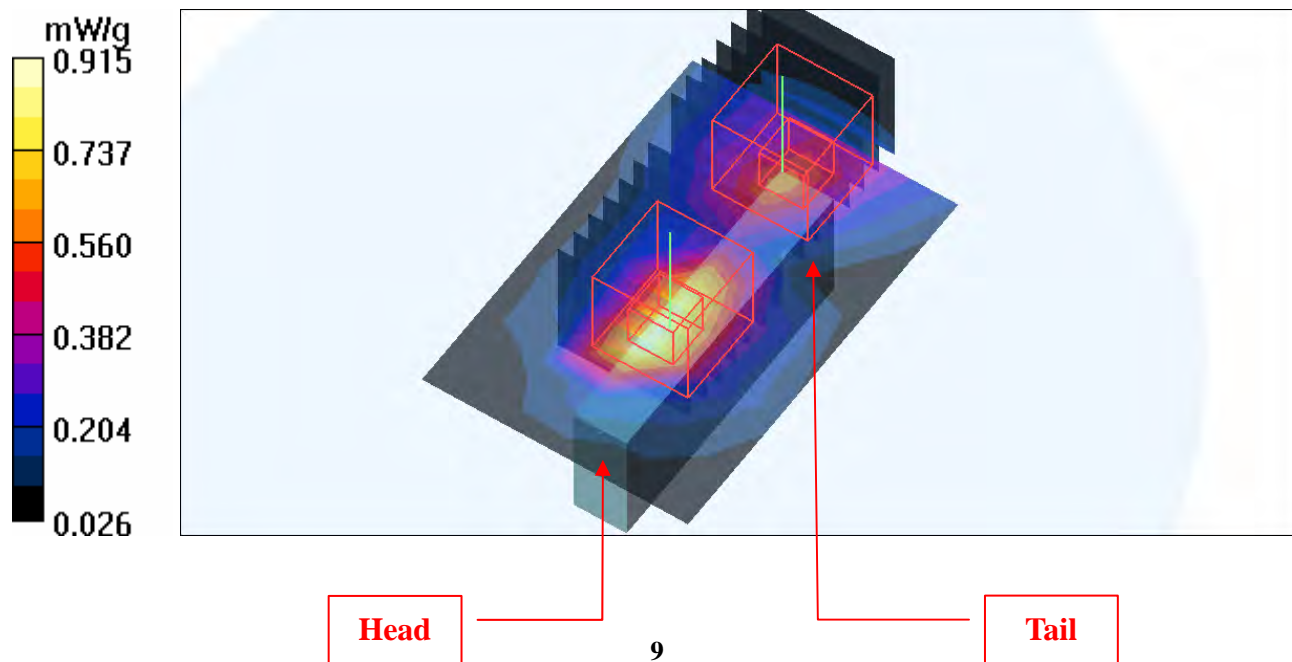

Test Laboratory: Bureau Veritas ADT

## M08-11g-Ch6

**DUT: Wireless N USB Adapter ; Type: DWA-130E1**

Communication System: 802.11g ; Frequency: 2437 MHz ; Duty Cycle: 1:1 ; Modulation type: BPSK  
 Medium: MSL2450 Medium parameters used:  $f = 2437$  MHz;  $\sigma = 1.96$  mho/m;  $\epsilon_r = 54.2$ ;  $\rho = 1000$  kg/m<sup>3</sup>  
 Phantom section: Flat Section ; Separation distance : 5 mm (The edge side of the EUT to the Phantom)

DASY4 Configuration:

- Probe: EX3DV3 - SN3504 ; ConvF(7.53, 7.53, 7.53) ; Calibrated: 2009/1/21
- Sensor-Surface: 3mm (Mechanical Surface Detection)
- Electronics: DAE3 Sn510 ; Calibrated: 2009/1/21
- Phantom: SAM 12 ; Type: SAM V4.0 ; Serial: TP 1202
- Measurement SW: DASY4, V4.7 Build 80 ; Postprocessing SW: SEMCAD, V1.8 Build 186

**Mid Channel 6/Area Scan (5x7x1):** Measurement grid: dx=15mm, dy=15mm

Maximum value of SAR (measured) = 0.453 mW/g

**Mid Channel 6/Zoom Scan (7x7x7) (7x7x7)/Cube 0:** Measurement grid: dx=5mm, dy=5mm, dz=5mm

Reference Value = 7.19 V/m

Peak SAR (extrapolated) = 0.808 W/kg

**SAR(1 g) = 0.399 mW/g; SAR(10 g) = 0.183 mW/g**

Maximum value of SAR (measured) = 0.533 mW/g

**Mid Channel 6/Zoom Scan (7x7x7) (7x7x7)/Cube 1:** Measurement grid: dx=5mm, dy=5mm, dz=5mm

Reference Value = 7.19 V/m

Peak SAR (extrapolated) = 0.532 W/kg

**SAR(1 g) = 0.285 mW/g; SAR(10 g) = 0.148 mW/g**

Maximum value of SAR (measured) = 0.359 mW/g

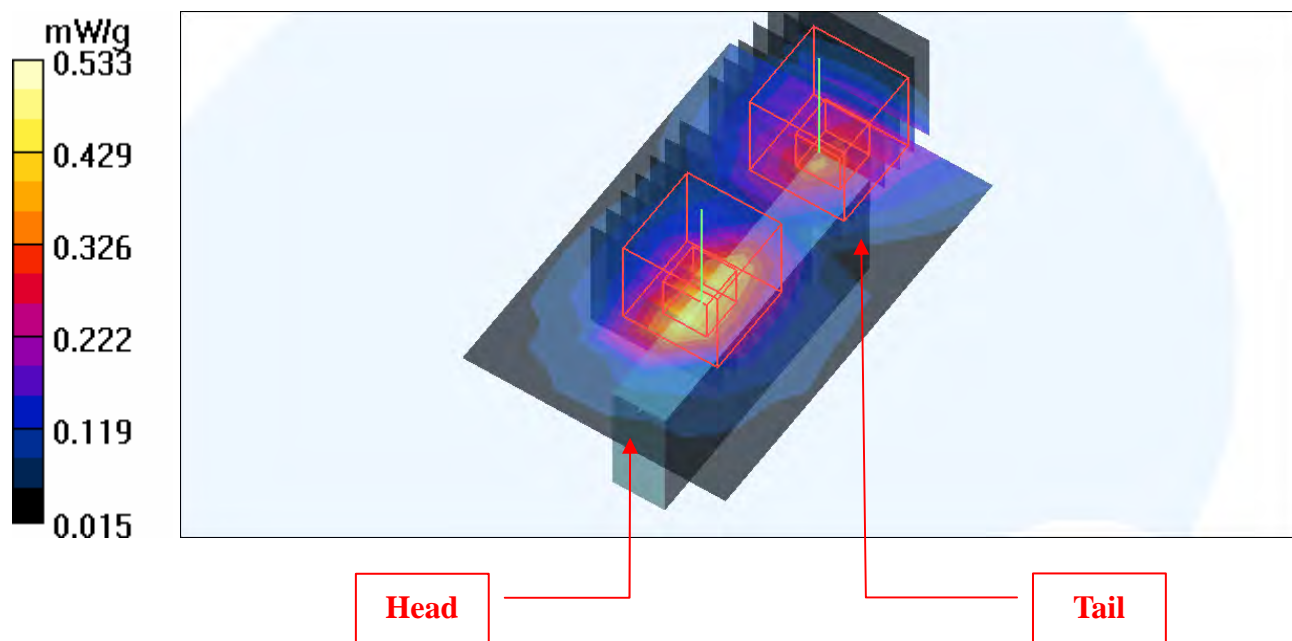

Test Laboratory: Bureau Veritas ADT

**M09-11N 20M-Ch6****DUT: Wireless N USB Adapter ; Type: DWA-130E1**

Communication System: 2.4G 11n span20 ; Frequency: 2437 MHz ; Duty Cycle: 1:1 ; Modulation type: BPSK

Medium: MSL2450 Medium parameters used:  $f = 2437$  MHz;  $\sigma = 1.96$  mho/m;  $\epsilon_r = 54.2$ ;  $\rho = 1000$  kg/m<sup>3</sup>  
Phantom section: Flat Section ; Separation distance : 5 mm (The edge side of the EUT to the Phantom)

DASY4 Configuration:

- Probe: EX3DV3 - SN3504 ; ConvF(7.53, 7.53, 7.53) ; Calibrated: 2009/1/21
- Sensor-Surface: 3mm (Mechanical Surface Detection)
- Electronics: DAE3 Sn510 ; Calibrated: 2009/1/21
- Phantom: SAM 12 ; Type: SAM V4.0 ; Serial: TP 1202
- Measurement SW: DASY4, V4.7 Build 80 ; Postprocessing SW: SEMCAD, V1.8 Build 186

**Mid Channel 6/Area Scan (5x7x1):** Measurement grid: dx=15mm, dy=15mm

Maximum value of SAR (measured) = 0.441 mW/g

**Mid Channel 6/Zoom Scan (7x7x7) (7x7x7)/Cube 0:** Measurement grid: dx=5mm, dy=5mm, dz=5mm

Reference Value = 7.20 V/m

Peak SAR (extrapolated) = 0.775 W/kg

**SAR(1 g) = 0.386 mW/g; SAR(10 g) = 0.178 mW/g**

Maximum value of SAR (measured) = 0.513 mW/g

**Mid Channel 6/Zoom Scan (7x7x7) (7x7x7)/Cube 1:** Measurement grid: dx=5mm, dy=5mm, dz=5mm

Reference Value = 7.20 V/m

Peak SAR (extrapolated) = 0.524 W/kg

**SAR(1 g) = 0.278 mW/g; SAR(10 g) = 0.146 mW/g**

Maximum value of SAR (measured) = 0.351 mW/g

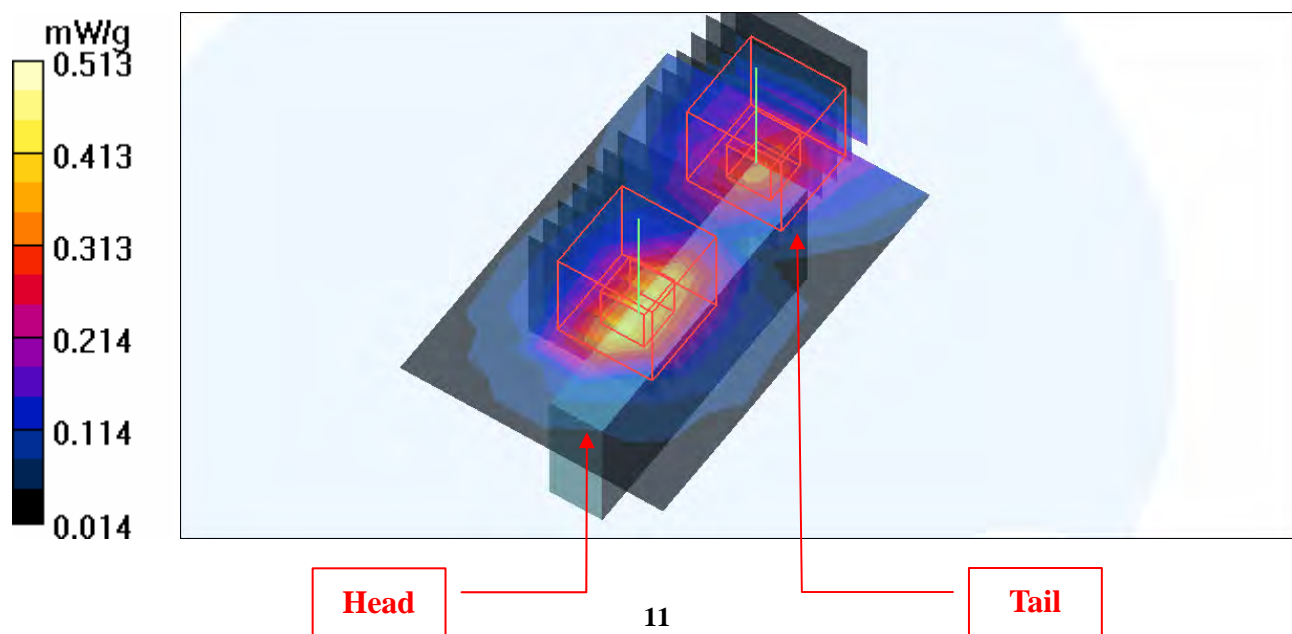

Test Laboratory: Bureau Veritas ADT

### M10-11N 40M-Ch4

**DUT: Wireless N USB Adapter ; Type: DWA-130E1**

Communication System: 802.11n 40MHz ; Frequency: 2437 MHz ; Duty Cycle: 1:1 ; Modulation type: BPSK

Medium: MSL2450 Medium parameters used:  $f = 2437$  MHz;  $\sigma = 1.96$  mho/m;  $\epsilon_r = 54.2$ ;  $\rho = 1000$  kg/m<sup>3</sup>  
Phantom section: Flat Section ; Separation distance : 5 mm (The edge side of the EUT to the Phantom)

DASY4 Configuration:

- Probe: EX3DV3 - SN3504 ; ConvF(7.53, 7.53, 7.53) ; Calibrated: 2009/1/21
- Sensor-Surface: 3mm (Mechanical Surface Detection)
- Electronics: DAE3 Sn510 ; Calibrated: 2009/1/21
- Phantom: SAM 12 ; Type: SAM V4.0 ; Serial: TP 1202
- Measurement SW: DASY4, V4.7 Build 80 ; Postprocessing SW: SEMCAD, V1.8 Build 186

**Mid Channel 4/Area Scan (5x7x1):** Measurement grid: dx=15mm, dy=15mm

Maximum value of SAR (measured) = 0.409 mW/g

**Mid Channel 4/Zoom Scan (7x7x7) (7x7x7)/Cube 0:** Measurement grid: dx=5mm, dy=5mm, dz=5mm

Reference Value = 6.90 V/m

Peak SAR (extrapolated) = 0.642 W/kg

**SAR(1 g) = 0.322 mW/g; SAR(10 g) = 0.149 mW/g**

Maximum value of SAR (measured) = 0.431 mW/g

**Mid Channel 4/Zoom Scan (7x7x7) (7x7x7)/Cube 1:** Measurement grid: dx=5mm, dy=5mm, dz=5mm

Reference Value = 6.90 V/m

Peak SAR (extrapolated) = 0.487 W/kg

**SAR(1 g) = 0.238 mW/g; SAR(10 g) = 0.126 mW/g**

Maximum value of SAR (measured) = 0.307 mW/g

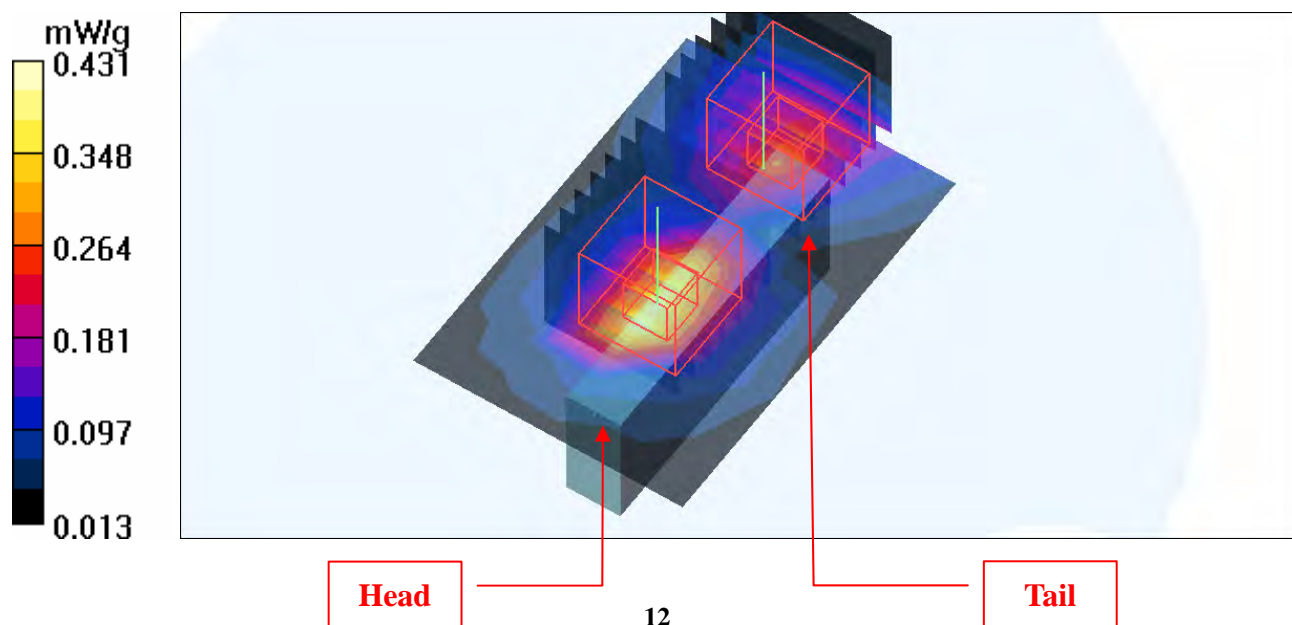

Test Laboratory: Bureau Veritas ADT

## M11-11b-Ch11

**DUT: Wireless N USB Adapter ; Type: DWA-130E1**

Communication System: 802.11b ; Frequency: 2462 MHz ; Duty Cycle: 1:1 ; Modulation type: DBPSK

Medium: MSL2450 Medium parameters used:  $f = 2462$  MHz;  $\sigma = 2$  mho/m;  $\epsilon_r = 54$ ;  $\rho = 1000$  kg/m<sup>3</sup>

Phantom section: Flat Section ; Separation distance : 5 mm (The front side of the EUT to the Phantom)

DASY4 Configuration:

- Probe: EX3DV3 - SN3504 ; ConvF(7.53, 7.53, 7.53) ; Calibrated: 2009/1/21
- Sensor-Surface: 3mm (Mechanical Surface Detection)
- Electronics: DAE3 Sn510 ; Calibrated: 2009/1/21
- Phantom: SAM 12 ; Type: SAM V4.0 ; Serial: TP 1202
- Measurement SW: DASY4, V4.7 Build 80 ; Postprocessing SW: SEMCAD, V1.8 Build 186

**High Channel 11/Area Scan (5x9x1):** Measurement grid: dx=15mm, dy=15mm

Maximum value of SAR (measured) = 0.549 mW/g

**High Channel 11/Zoom Scan (7x7x7) (7x7x7)/Cube 0:** Measurement grid: dx=5mm, dy=5mm, dz=5mm

Reference Value = 11.7 V/m

Peak SAR (extrapolated) = 0.867 W/kg

**SAR(1 g) = 0.421 mW/g; SAR(10 g) = 0.219 mW/g**

Maximum value of SAR (measured) = 0.536 mW/g

**High Channel 11/Zoom Scan (7x7x7) (7x7x7)/Cube 1:** Measurement grid: dx=5mm, dy=5mm, dz=5mm

Reference Value = 11.7 V/m

Peak SAR (extrapolated) = 0.791 W/kg

**SAR(1 g) = 0.419 mW/g; SAR(10 g) = 0.212 mW/g**

Maximum value of SAR (measured) = 0.535 mW/g

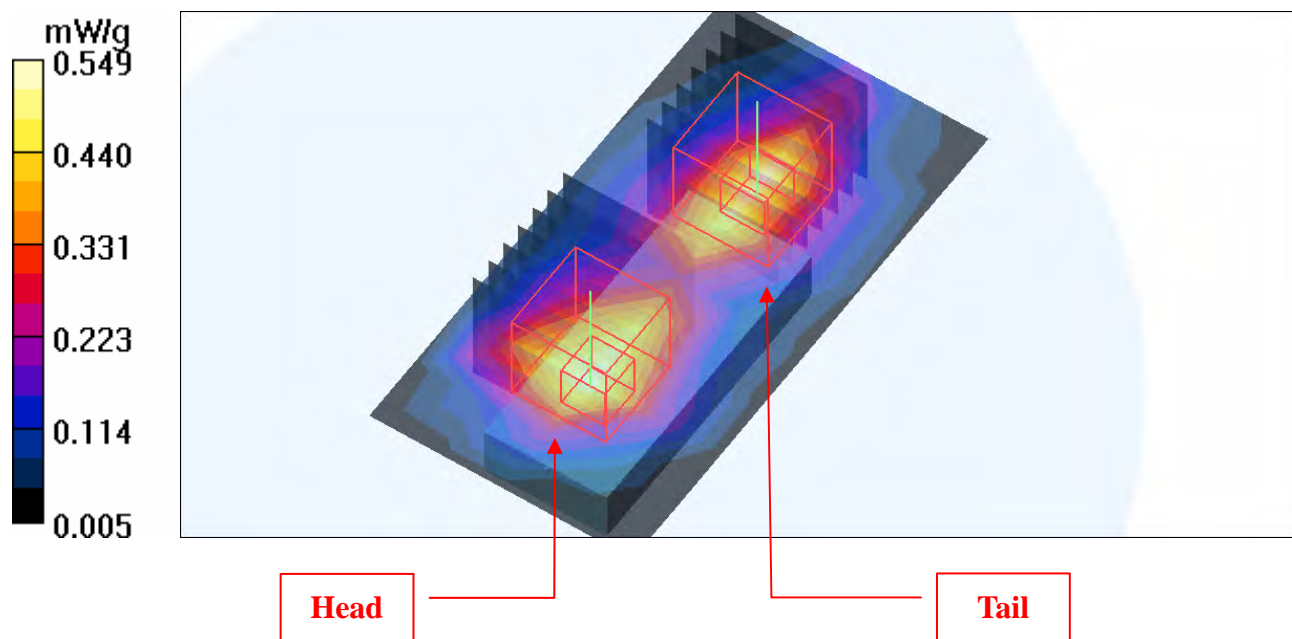

Test Laboratory: Bureau Veritas ADT

**M12-11b-Ch11 w/o EPROM****DUT: Wireless N USB Adapter ; Type: DWA-130E1**

Communication System: 802.11b ; Frequency: 2462 MHz ; Duty Cycle: 1:1 ; Modulation type: DBPSK

Medium: MSL2450 Medium parameters used:  $f = 2462$  MHz;  $\sigma = 2$  mho/m;  $\epsilon_r = 54$ ;  $\rho = 1000$  kg/m<sup>3</sup>

Phantom section: Flat Section ; Separation distance : 5 mm (The front side of the EUT to the Phantom)

DASY4 Configuration:

- Probe: EX3DV3 - SN3504 ; ConvF(7.53, 7.53, 7.53) ; Calibrated: 2009/1/21
- Sensor-Surface: 3mm (Mechanical Surface Detection)
- Electronics: DAE3 Sn510 ; Calibrated: 2009/1/21
- Phantom: SAM 12 ; Type: SAM V4.0 ; Serial: TP 1202
- Measurement SW: DASY4, V4.7 Build 80 ; Postprocessing SW: SEMCAD, V1.8 Build 186

**High Channel 11/Area Scan (5x9x1):** Measurement grid: dx=15mm, dy=15mm

Maximum value of SAR (measured) = 0.532 mW/g

**High Channel 11/Zoom Scan (7x7x7) (7x7x7)/Cube 0:** Measurement grid: dx=5mm, dy=5mm, dz=5mm

Reference Value = 11.4 V/m

Peak SAR (extrapolated) = 0.830 W/kg

**SAR(1 g) = 0.390 mW/g; SAR(10 g) = 0.203 mW/g**

Maximum value of SAR (measured) = 0.507 mW/g

**High Channel 11/Zoom Scan (7x7x7) (7x7x7)/Cube 1:** Measurement grid: dx=5mm, dy=5mm, dz=5mm

Reference Value = 11.4 V/m

Peak SAR (extrapolated) = 0.690 W/kg

**SAR(1 g) = 0.358 mW/g; SAR(10 g) = 0.179 mW/g**

Maximum value of SAR (measured) = 0.457 mW/g

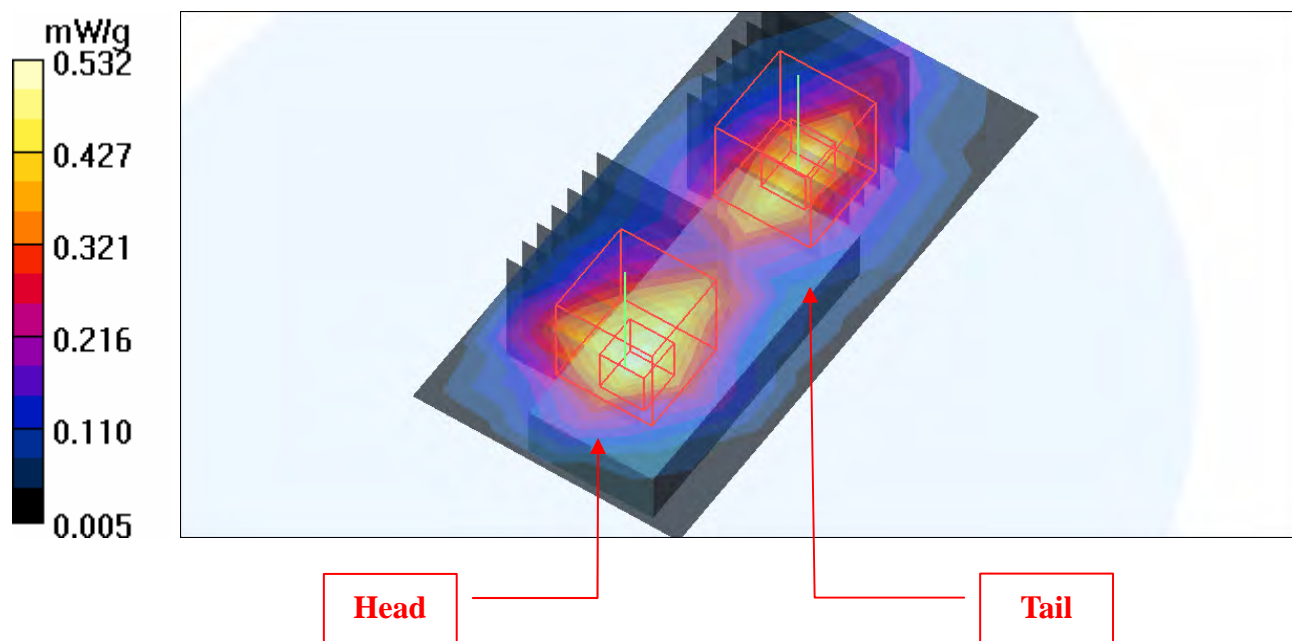

Test Laboratory: Bureau Veritas ADT

### M13-11g-Ch6

**DUT: Wireless N USB Adapter ; Type: DWA-130E1**

Communication System: 802.11g ; Frequency: 2437 MHz ; Duty Cycle: 1:1 ; Modulation type: BPSK  
 Medium: MSL2450 Medium parameters used:  $f = 2437$  MHz;  $\sigma = 1.96$  mho/m;  $\epsilon_r = 54.2$ ;  $\rho = 1000$  kg/m<sup>3</sup>  
 Phantom section: Flat Section ; Separation distance : 5 mm (The front side of the EUT to the Phantom)

DASY4 Configuration:

- Probe: EX3DV3 - SN3504 ; ConvF(7.53, 7.53, 7.53) ; Calibrated: 2009/1/21
- Sensor-Surface: 3mm (Mechanical Surface Detection)
- Electronics: DAE3 Sn510 ; Calibrated: 2009/1/21
- Phantom: SAM 12 ; Type: SAM V4.0 ; Serial: TP 1202
- Measurement SW: DASY4, V4.7 Build 80 ; Postprocessing SW: SEMCAD, V1.8 Build 186

**Mid Channel 6/Area Scan (5x9x1):** Measurement grid: dx=15mm, dy=15mm

Maximum value of SAR (measured) = 0.394 mW/g

**Mid Channel 6/Zoom Scan (7x7x7) (7x7x7)/Cube 0:** Measurement grid: dx=5mm, dy=5mm, dz=5mm

Reference Value = 9.05 V/m

Peak SAR (extrapolated) = 0.664 W/kg

**SAR(1 g) = 0.323 mW/g; SAR(10 g) = 0.166 mW/g**

Maximum value of SAR (measured) = 0.413 mW/g

**Mid Channel 6/Zoom Scan (7x7x7) (7x7x7)/Cube 1:** Measurement grid: dx=5mm, dy=5mm, dz=5mm

Reference Value = 9.05 V/m

Peak SAR (extrapolated) = 0.583 W/kg

**SAR(1 g) = 0.309 mW/g; SAR(10 g) = 0.156 mW/g**

Maximum value of SAR (measured) = 0.396 mW/g

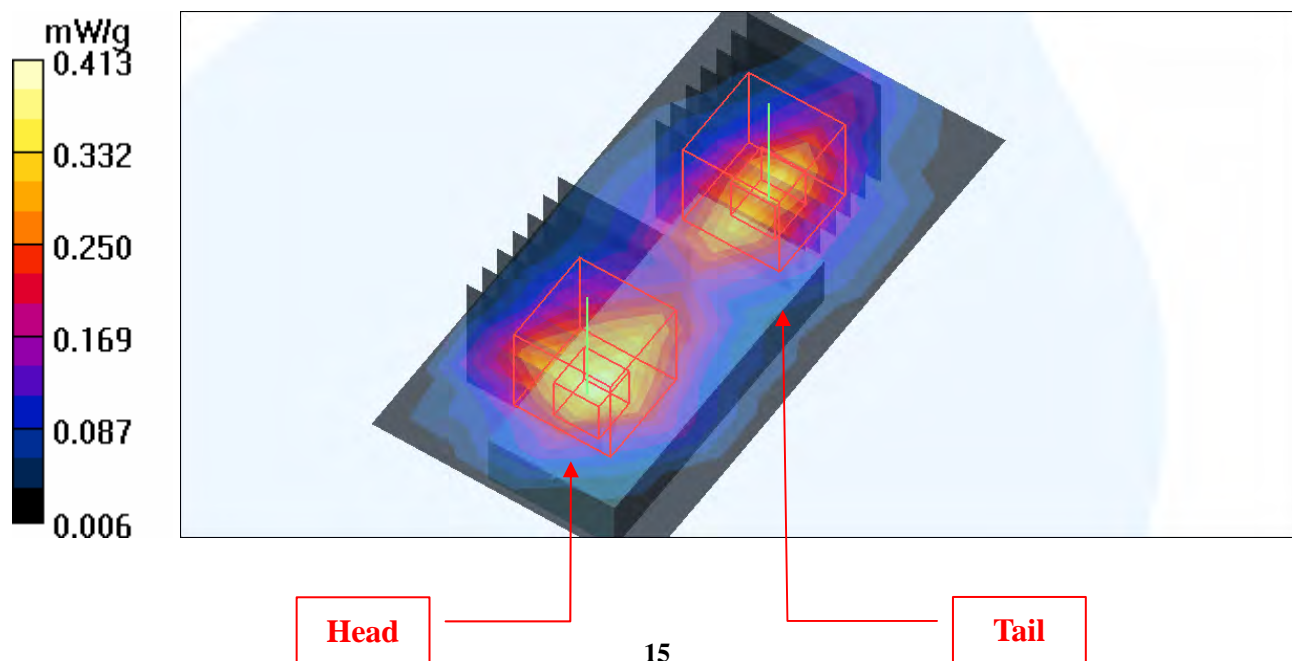



Test Laboratory: Bureau Veritas ADT

### M14-11N 20M-Ch6

**DUT: Wireless N USB Adapter ; Type: DWA-130E1**

Communication System: 2.4G 11n span20 ; Frequency: 2437 MHz ; Duty Cycle: 1:1 ; Modulation type: BPSK

Medium: MSL2450 Medium parameters used:  $f = 2437$  MHz;  $\sigma = 1.96$  mho/m;  $\epsilon_r = 54.2$ ;  $\rho = 1000$  kg/m<sup>3</sup>  
Phantom section: Flat Section ; Separation distance : 5 mm (The front side of the EUT to the Phantom)

DASY4 Configuration:

- Probe: EX3DV3 - SN3504 ; ConvF(7.53, 7.53, 7.53) ; Calibrated: 2009/1/21
- Sensor-Surface: 3mm (Mechanical Surface Detection)
- Electronics: DAE3 Sn510 ; Calibrated: 2009/1/21
- Phantom: SAM 12 ; Type: SAM V4.0 ; Serial: TP 1202
- Measurement SW: DASY4, V4.7 Build 80 ; Postprocessing SW: SEMCAD, V1.8 Build 186

**Mid Channel 6/Area Scan (5x9x1):** Measurement grid: dx=15mm, dy=15mm

Maximum value of SAR (measured) = 0.378 mW/g

**Mid Channel 6/Zoom Scan (7x7x7) (7x7x7)/Cube 0:** Measurement grid: dx=5mm, dy=5mm, dz=5mm

Reference Value = 11.5 V/m

Peak SAR (extrapolated) = 0.683 W/kg

**SAR(1 g) = 0.312 mW/g; SAR(10 g) = 0.154 mW/g**

Maximum value of SAR (measured) = 0.414 mW/g

**Mid Channel 6/Zoom Scan (7x7x7) (7x7x7)/Cube 1:** Measurement grid: dx=5mm, dy=5mm, dz=5mm

Reference Value = 11.5 V/m

Peak SAR (extrapolated) = 0.461 W/kg

**SAR(1 g) = 0.236 mW/g; SAR(10 g) = 0.118 mW/g**

Maximum value of SAR (measured) = 0.304 mW/g

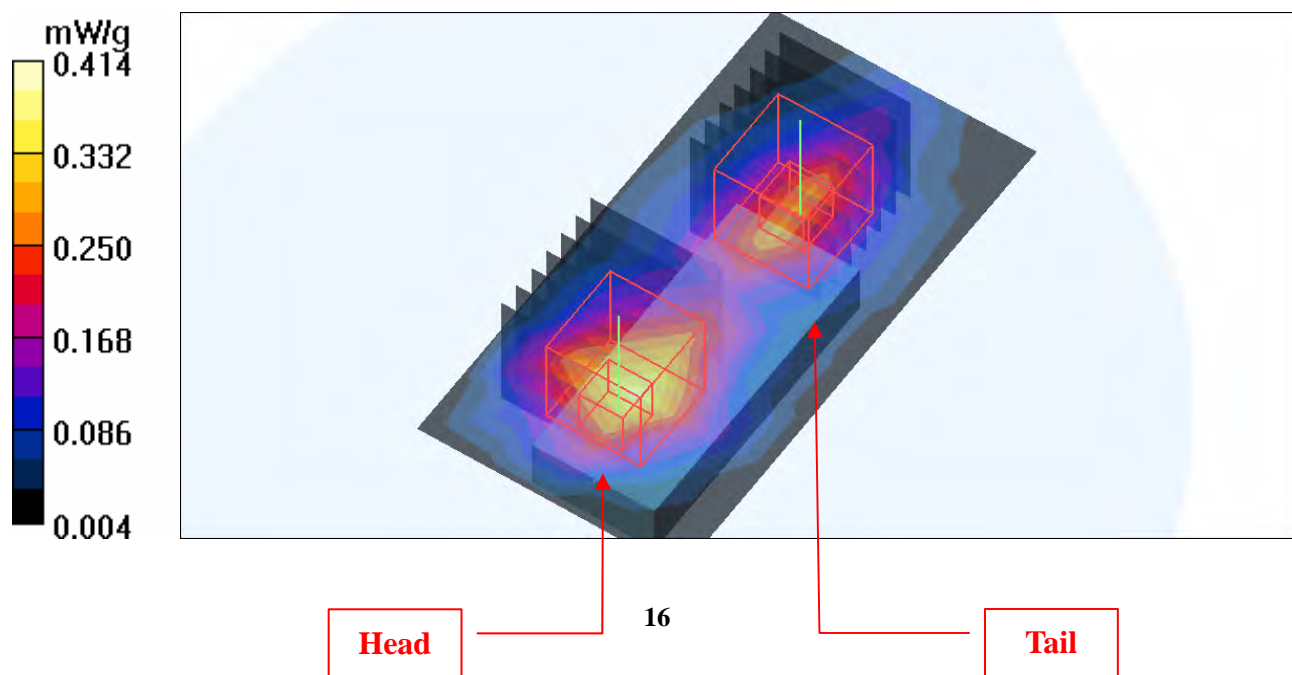

Test Laboratory: Bureau Veritas ADT

**M15-11N 40M-Ch4****DUT: Wireless N USB Adapter ; Type: DWA-130E1**

Communication System: 802.11n 40MHz ; Frequency: 2437 MHz ; Duty Cycle: 1:1 ; Modulation type: BPSK

Medium: MSL2450 Medium parameters used:  $f = 2437$  MHz;  $\sigma = 1.96$  mho/m;  $\epsilon_r = 54.2$ ;  $\rho = 1000$  kg/m<sup>3</sup>  
Phantom section: Flat Section ; Separation distance : 5 mm (The front side of the EUT to the Phantom)

DASY4 Configuration:

- Probe: EX3DV3 - SN3504 ; ConvF(7.53, 7.53, 7.53) ; Calibrated: 2009/1/21
- Sensor-Surface: 3mm (Mechanical Surface Detection)
- Electronics: DAE3 Sn510 ; Calibrated: 2009/1/21
- Phantom: SAM 12 ; Type: SAM V4.0 ; Serial: TP 1202
- Measurement SW: DASY4, V4.7 Build 80 ; Postprocessing SW: SEMCAD, V1.8 Build 186

**Mid Channel 4/Area Scan (5x9x1):** Measurement grid: dx=15mm, dy=15mm

Maximum value of SAR (measured) = 0.278 mW/g

**Mid Channel 4/Zoom Scan (7x7x7) (7x7x7)/Cube 0:** Measurement grid: dx=5mm, dy=5mm, dz=5mm

Reference Value = 8.85 V/m

Peak SAR (extrapolated) = 0.515 W/kg

**SAR(1 g) = 0.237 mW/g; SAR(10 g) = 0.117 mW/g**

Maximum value of SAR (measured) = 0.313 mW/g

**Mid Channel 4/Zoom Scan (7x7x7) (7x7x7)/Cube 1:** Measurement grid: dx=5mm, dy=5mm, dz=5mm

Reference Value = 8.85 V/m

Peak SAR (extrapolated) = 0.352 W/kg

**SAR(1 g) = 0.182 mW/g; SAR(10 g) = 0.091 mW/g**

Maximum value of SAR (measured) = 0.230 mW/g

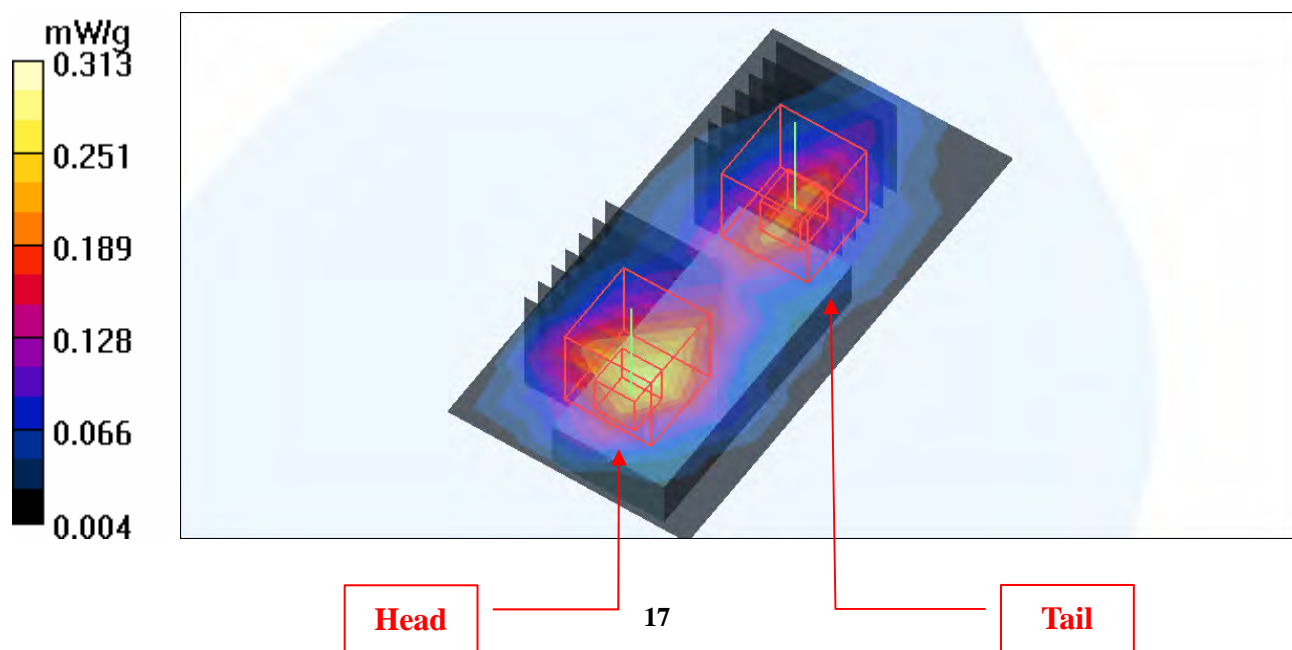

Test Laboratory: Bureau Veritas ADT

### M16-11b-Ch11

**DUT: Wireless N USB Adapter ; Type: DWA-130E1**

Communication System: 802.11b ; Frequency: 2462 MHz ; Duty Cycle: 1:1 ; Modulation type: DBPSK

Medium: MSL2450 Medium parameters used:  $f = 2462$  MHz;  $\sigma = 2$  mho/m;  $\epsilon_r = 54$ ;  $\rho = 1000$  kg/m<sup>3</sup>

Phantom section: Flat Section ; Separation distance : 5 mm (The edge side of the EUT to the Phantom)

DASY4 Configuration:

- Probe: EX3DV3 - SN3504 ; ConvF(7.53, 7.53, 7.53) ; Calibrated: 2009/1/21
- Sensor-Surface: 3mm (Mechanical Surface Detection)
- Electronics: DAE3 Sn510 ; Calibrated: 2009/1/21
- Phantom: SAM 12 ; Type: SAM V4.0 ; Serial: TP 1202
- Measurement SW: DASY4, V4.7 Build 80 ; Postprocessing SW: SEMCAD, V1.8 Build 186

**High Channel 11/Area Scan (5x7x1):** Measurement grid: dx=15mm, dy=15mm

Maximum value of SAR (measured) = 0.207 mW/g

**High Channel 11/Zoom Scan (7x7x7) (7x7x7)/Cube 0:** Measurement grid: dx=5mm, dy=5mm, dz=5mm

Reference Value = 7.04 V/m

Peak SAR (extrapolated) = 0.304 W/kg

**SAR(1 g) = 0.155 mW/g; SAR(10 g) = 0.079 mW/g**

Maximum value of SAR (measured) = 0.197 mW/g

**High Channel 11/Zoom Scan (7x7x7) (7x7x7)/Cube 1:** Measurement grid: dx=5mm, dy=5mm, dz=5mm

Reference Value = 7.04 V/m

Peak SAR (extrapolated) = 0.214 W/kg

**SAR(1 g) = 0.091 mW/g; SAR(10 g) = 0.041 mW/g**

Maximum value of SAR (measured) = 0.119 mW/g

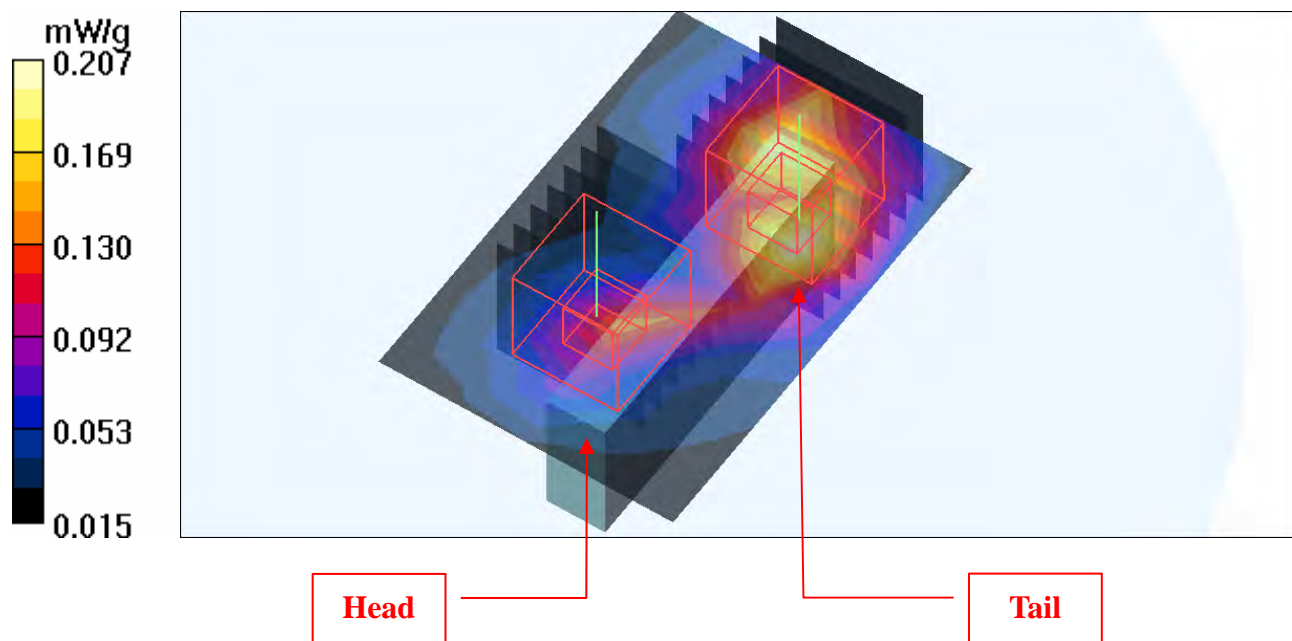

Test Laboratory: Bureau Veritas ADT

### M17-11b-Ch11 w/o EPROM

**DUT: Wireless N USB Adapter ; Type: DWA-130E1**

Communication System: 802.11b ; Frequency: 2462 MHz ; Duty Cycle: 1:1 ; Modulation type: DBPSK

Medium: MSL2450 Medium parameters used:  $f = 2462$  MHz;  $\sigma = 2$  mho/m;  $\epsilon_r = 54$ ;  $\rho = 1000$  kg/m<sup>3</sup>

Phantom section: Flat Section ; Separation distance : 5 mm (The edge side of the EUT to the Phantom)

DASY4 Configuration:

- Probe: EX3DV3 - SN3504 ; ConvF(7.53, 7.53, 7.53) ; Calibrated: 2009/1/21
- Sensor-Surface: 3mm (Mechanical Surface Detection)
- Electronics: DAE3 Sn510 ; Calibrated: 2009/1/21
- Phantom: SAM 12 ; Type: SAM V4.0 ; Serial: TP 1202
- Measurement SW: DASY4, V4.7 Build 80 ; Postprocessing SW: SEMCAD, V1.8 Build 186

**High Channel 11/Area Scan (5x7x1):** Measurement grid: dx=15mm, dy=15mm

Maximum value of SAR (measured) = 0.185 mW/g

**High Channel 11/Zoom Scan (7x7x7) (7x7x7)/Cube 0:** Measurement grid: dx=5mm, dy=5mm, dz=5mm

Reference Value = 6.69 V/m

Peak SAR (extrapolated) = 0.285 W/kg

**SAR(1 g) = 0.144 mW/g; SAR(10 g) = 0.072 mW/g**

Maximum value of SAR (measured) = 0.180 mW/g

**High Channel 11/Zoom Scan (7x7x7) (7x7x7)/Cube 1:** Measurement grid: dx=5mm, dy=5mm, dz=5mm

Reference Value = 6.69 V/m

Peak SAR (extrapolated) = 0.226 W/kg

**SAR(1 g) = 0.097 mW/g; SAR(10 g) = 0.043 mW/g**

Maximum value of SAR (measured) = 0.130 mW/g

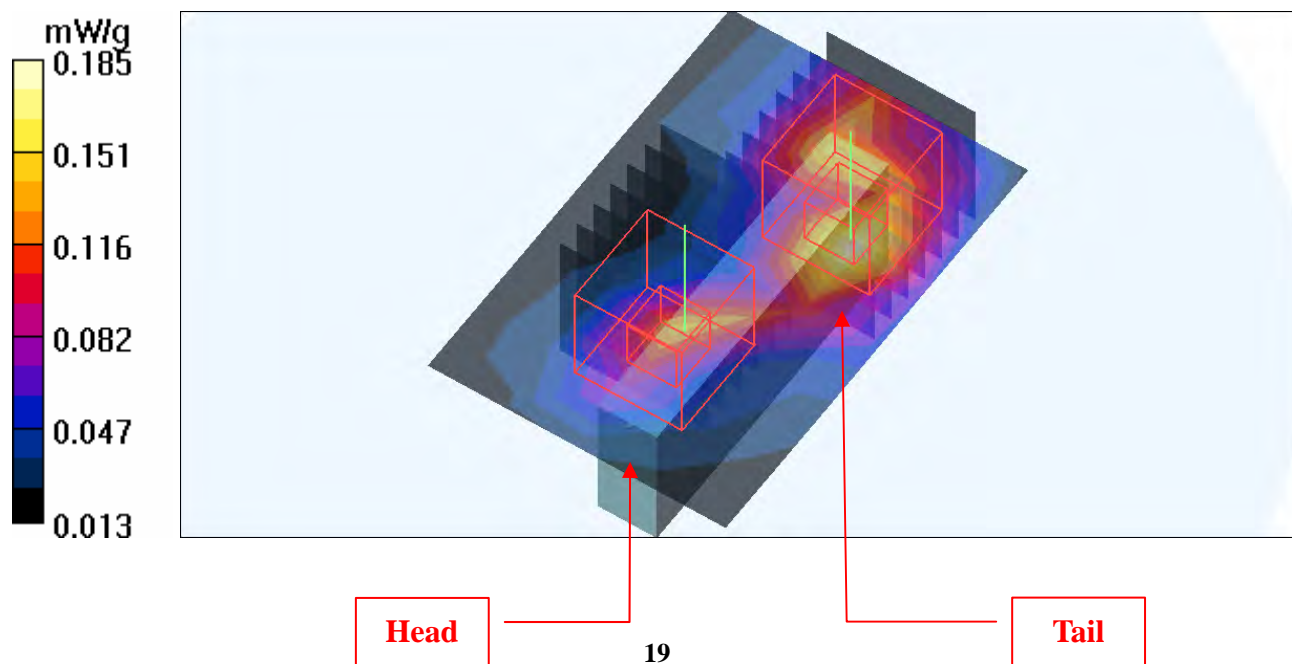

Test Laboratory: Bureau Veritas ADT

## M18-11g-Ch6

**DUT: Wireless N USB Adapter ; Type: DWA-130E1**

Communication System: 802.11g ; Frequency: 2437 MHz ; Duty Cycle: 1:1 ; Modulation type: BPSK  
Medium: MSL2450 Medium parameters used:  $f = 2437$  MHz;  $\sigma = 1.96$  mho/m;  $\epsilon_r = 54.2$ ;  $\rho = 1000$  kg/m<sup>3</sup>  
Phantom section: Flat Section ; Separation distance : 5 mm (The edge side of the EUT to the Phantom)

DASY4 Configuration:

- Probe: EX3DV3 - SN3504 ; ConvF(7.53, 7.53, 7.53) ; Calibrated: 2009/1/21
- Sensor-Surface: 3mm (Mechanical Surface Detection)
- Electronics: DAE3 Sn510 ; Calibrated: 2009/1/21
- Phantom: SAM 12 ; Type: SAM V4.0 ; Serial: TP 1202
- Measurement SW: DASY4, V4.7 Build 80 ; Postprocessing SW: SEMCAD, V1.8 Build 186

**Mid Channel 6/Area Scan (5x7x1):** Measurement grid: dx=15mm, dy=15mm

Maximum value of SAR (measured) = 0.097 mW/g

**Mid Channel 6/Zoom Scan (7x7x7) (7x7x7)/Cube 0:** Measurement grid: dx=5mm, dy=5mm, dz=5mm

Reference Value = 5.18 V/m

Peak SAR (extrapolated) = 0.170 W/kg

**SAR(1 g) = 0.085 mW/g; SAR(10 g) = 0.043 mW/g**

Maximum value of SAR (measured) = 0.108 mW/g

**Mid Channel 6/Zoom Scan (7x7x7) (7x7x7)/Cube 1:** Measurement grid: dx=5mm, dy=5mm, dz=5mm

Reference Value = 5.18 V/m

Peak SAR (extrapolated) = 0.159 W/kg

**SAR(1 g) = 0.067 mW/g; SAR(10 g) = 0.031 mW/g**

Maximum value of SAR (measured) = 0.091 mW/g

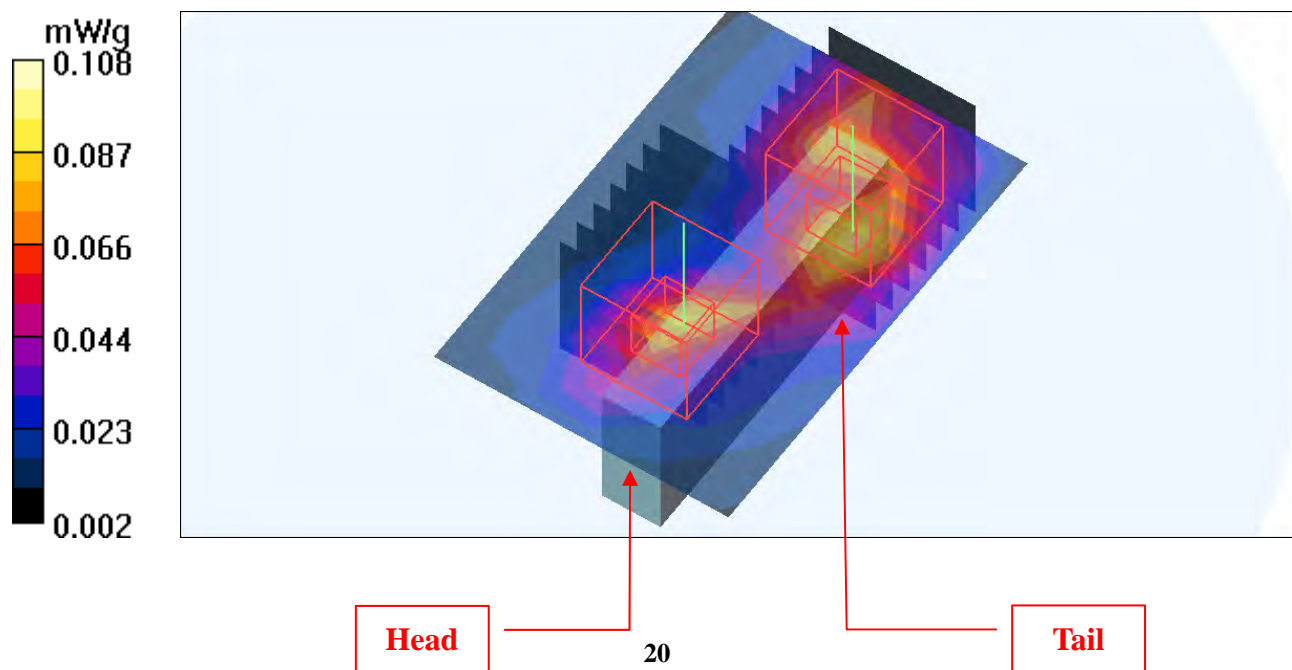

Test Laboratory: Bureau Veritas ADT

**M19-11N 20M-Ch6****DUT: Wireless N USB Adapter ; Type: DWA-130E1**

Communication System: 2.4G 11n span20 ; Frequency: 2437 MHz ; Duty Cycle: 1:1 ; Modulation type: BPSK

Medium: MSL2450 Medium parameters used:  $f = 2437$  MHz;  $\sigma = 1.96$  mho/m;  $\epsilon_r = 54.2$ ;  $\rho = 1000$  kg/m<sup>3</sup>  
Phantom section: Flat Section ; Separation distance : 5 mm (The edge side of the EUT to the Phantom)

DASY4 Configuration:

- Probe: EX3DV3 - SN3504 ; ConvF(7.53, 7.53, 7.53) ; Calibrated: 2009/1/21
- Sensor-Surface: 3mm (Mechanical Surface Detection)
- Electronics: DAE3 Sn510 ; Calibrated: 2009/1/21
- Phantom: SAM 12 ; Type: SAM V4.0 ; Serial: TP 1202
- Measurement SW: DASY4, V4.7 Build 80 ; Postprocessing SW: SEMCAD, V1.8 Build 186

**Mid Channel 6/Area Scan (5x7x1):** Measurement grid: dx=15mm, dy=15mm

Maximum value of SAR (measured) = 0.118 mW/g

**Mid Channel 6/Zoom Scan (7x7x7) (7x7x7)/Cube 0:** Measurement grid: dx=5mm, dy=5mm, dz=5mm

Reference Value = 5.48 V/m

Peak SAR (extrapolated) = 0.191 W/kg

**SAR(1 g) = 0.096 mW/g; SAR(10 g) = 0.049 mW/g**

Maximum value of SAR (measured) = 0.124 mW/g

**Mid Channel 6/Zoom Scan (7x7x7) (7x7x7)/Cube 1:** Measurement grid: dx=5mm, dy=5mm, dz=5mm

Reference Value = 5.48 V/m

Peak SAR (extrapolated) = 0.146 W/kg

**SAR(1 g) = 0.064 mW/g; SAR(10 g) = 0.029 mW/g**

Maximum value of SAR (measured) = 0.086 mW/g

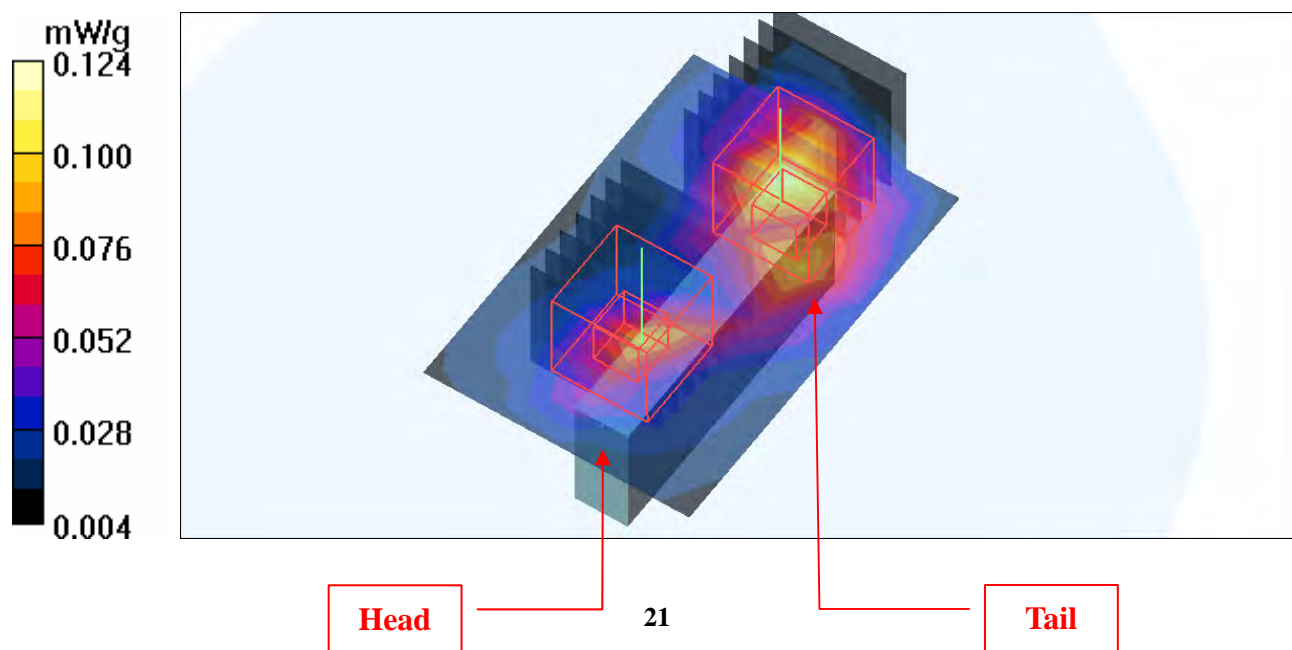

Test Laboratory: Bureau Veritas ADT

**M20-11N 40M-Ch4****DUT: Wireless N USB Adapter ; Type: DWA-130E1**

Communication System: 802.11n 40MHz ; Frequency: 2437 MHz ; Duty Cycle: 1:1 ; Modulation type: BPSK

Medium: MSL2450 Medium parameters used:  $f = 2437$  MHz;  $\sigma = 1.96$  mho/m;  $\epsilon_r = 54.2$ ;  $\rho = 1000$  kg/m<sup>3</sup>  
Phantom section: Flat Section ; Separation distance : 5 mm (The edge side of the EUT to the Phantom)

DASY4 Configuration:

- Probe: EX3DV3 - SN3504 ; ConvF(7.53, 7.53, 7.53) ; Calibrated: 2009/1/21
- Sensor-Surface: 3mm (Mechanical Surface Detection)
- Electronics: DAE3 Sn510 ; Calibrated: 2009/1/21
- Phantom: SAM 12 ; Type: SAM V4.0 ; Serial: TP 1202
- Measurement SW: DASY4, V4.7 Build 80 ; Postprocessing SW: SEMCAD, V1.8 Build 186

**Mid Channel 4/Area Scan (5x7x1):** Measurement grid: dx=15mm, dy=15mm

Maximum value of SAR (measured) = 0.084 mW/g

**Mid Channel 4/Zoom Scan (7x7x7) (7x7x7)/Cube 0:** Measurement grid: dx=5mm, dy=5mm, dz=5mm

Reference Value = 4.50 V/m

Peak SAR (extrapolated) = 0.142 W/kg

**SAR(1 g) = 0.071 mW/g; SAR(10 g) = 0.037 mW/g**

Maximum value of SAR (measured) = 0.091 mW/g

**Mid Channel 4/Zoom Scan (7x7x7) (7x7x7)/Cube 1:** Measurement grid: dx=5mm, dy=5mm, dz=5mm

Reference Value = 4.50 V/m

Peak SAR (extrapolated) = 0.119 W/kg

**SAR(1 g) = 0.051 mW/g; SAR(10 g) = 0.024 mW/g**

Maximum value of SAR (measured) = 0.067 mW/g

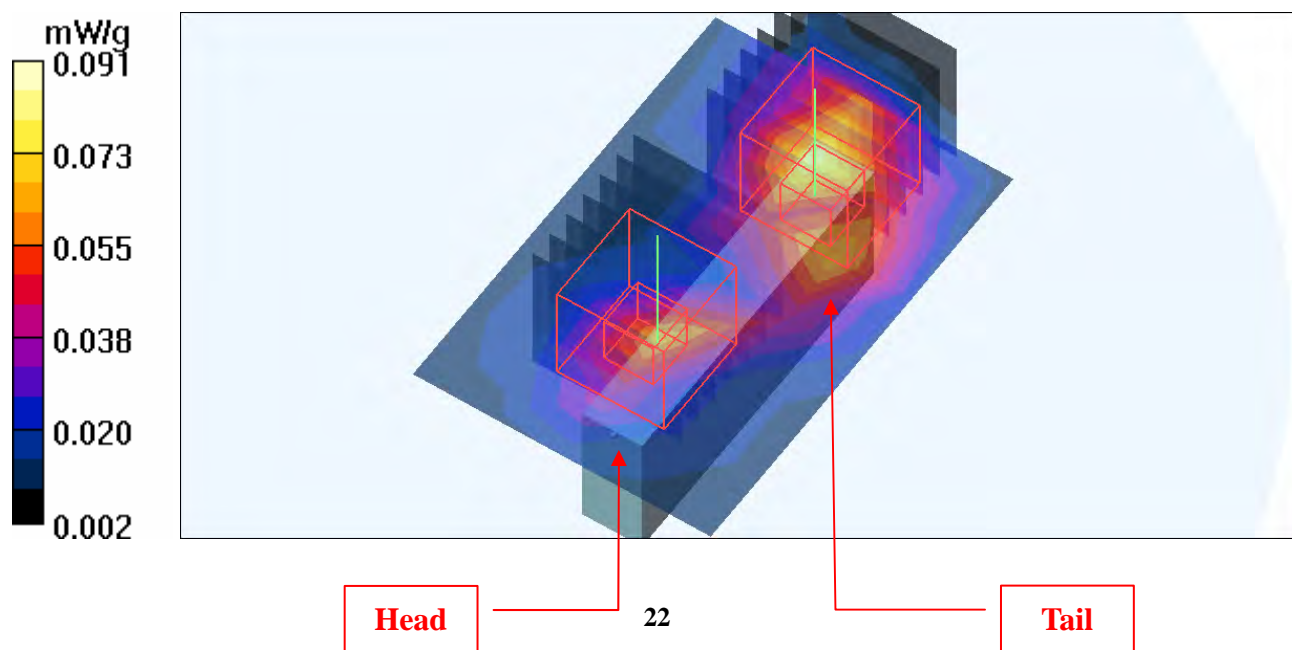

Test Laboratory: Bureau Veritas ADT

## M21-11b-Ch11

### DUT: Wireless N USB Adapter ; Type: DWA-130E1

Communication System: 802.11b ; Frequency: 2462 MHz ; Duty Cycle: 1:1 ; Modulation type: DBPSK  
Medium: MSL2450 Medium parameters used:  $f = 2462$  MHz;  $\sigma = 2$  mho/m;  $\epsilon_r = 54$ ;  $\rho = 1000$  kg/m<sup>3</sup>  
Phantom section: Flat Section ; Separation distance : 5 mm (The tip side of the EUT to the Phantom)

#### DASY4 Configuration:

- Probe: EX3DV3 - SN3504 ; ConvF(7.53, 7.53, 7.53) ; Calibrated: 2009/1/21
- Sensor-Surface: 3mm (Mechanical Surface Detection)
- Electronics: DAE3 Sn510 ; Calibrated: 2009/1/21
- Phantom: SAM 12 ; Type: SAM V4.0 ; Serial: TP 1202
- Measurement SW: DASY4, V4.7 Build 80 ; Postprocessing SW: SEMCAD, V1.8 Build 186

#### High Channel 11/Area Scan (5x5x1): Measurement grid: dx=15mm, dy=15mm

Maximum value of SAR (measured) = 0.162 mW/g

#### High Channel 11/Zoom Scan (7x7x7) (7x7x7)/Cube 0: Measurement grid: dx=5mm, dy=5mm, dz=5mm

Reference Value = 10.1 V/m

Peak SAR (extrapolated) = 0.189 W/kg

SAR(1 g) = **0.097** mW/g; SAR(10 g) = 0.050 mW/g

Maximum value of SAR (measured) = 0.124 mW/g

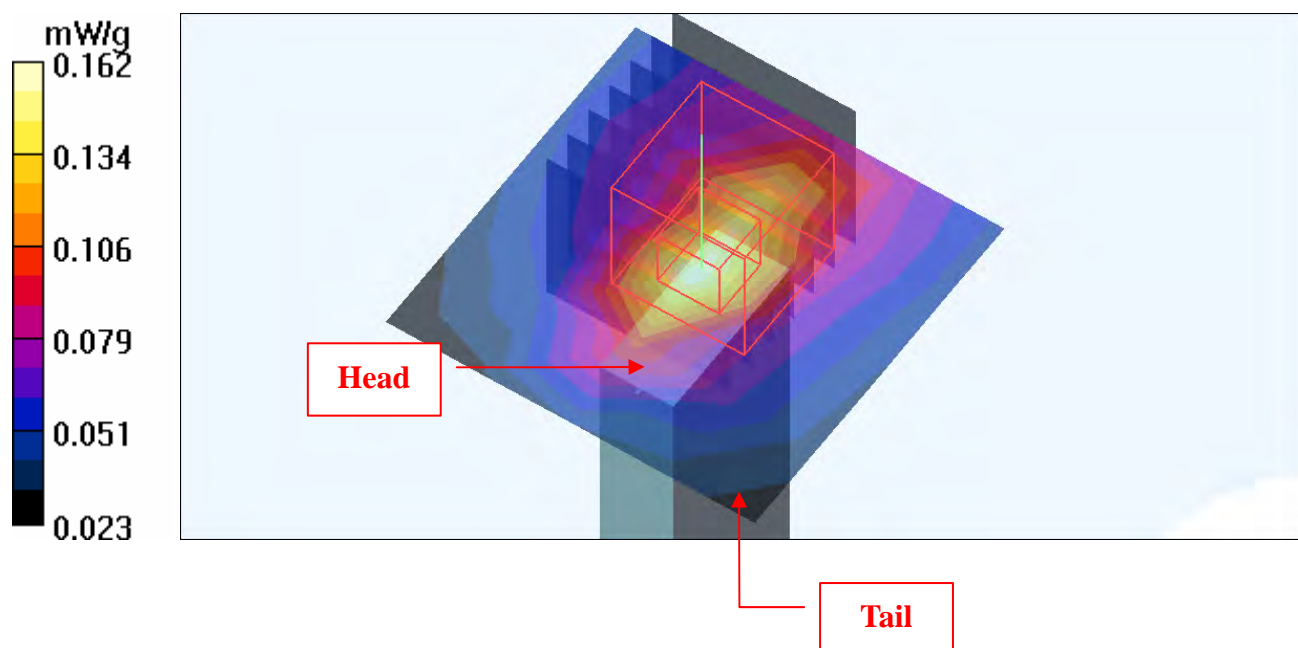



Test Laboratory: Bureau Veritas ADT

## M22-11b-Ch11 w/o EPROM

### DUT: Wireless N USB Adapter ; Type: DWA-130E1

Communication System: 802.11b ; Frequency: 2462 MHz ; Duty Cycle: 1:1 ; Modulation type: BPSK  
Medium: MSL2450 Medium parameters used:  $f = 2462$  MHz;  $\sigma = 2$  mho/m;  $\epsilon_r = 54$ ;  $\rho = 1000$  kg/m<sup>3</sup>  
Phantom section: Flat Section ; Separation distance : 5 mm (The tip side of the EUT to the Phantom)

#### DASY4 Configuration:

- Probe: EX3DV3 - SN3504 ; ConvF(7.53, 7.53, 7.53) ; Calibrated: 2009/1/21
- Sensor-Surface: 3mm (Mechanical Surface Detection)
- Electronics: DAE3 Sn510 ; Calibrated: 2009/1/21
- Phantom: SAM 12 ; Type: SAM V4.0 ; Serial: TP 1202
- Measurement SW: DASY4, V4.7 Build 80 ; Postprocessing SW: SEMCAD, V1.8 Build 186

#### High Channel 11/Area Scan (5x5x1): Measurement grid: dx=15mm, dy=15mm

Maximum value of SAR (measured) = 0.149 mW/g

#### High Channel 11/Zoom Scan (7x7x7) (7x7x7)/Cube 0: Measurement grid: dx=5mm, dy=5mm, dz=5mm

Reference Value = 9.89 V/m

Peak SAR (extrapolated) = 0.171 W/kg

SAR(1 g) = **0.088 mW/g**; SAR(10 g) = 0.046 mW/g

Maximum value of SAR (measured) = 0.110 mW/g

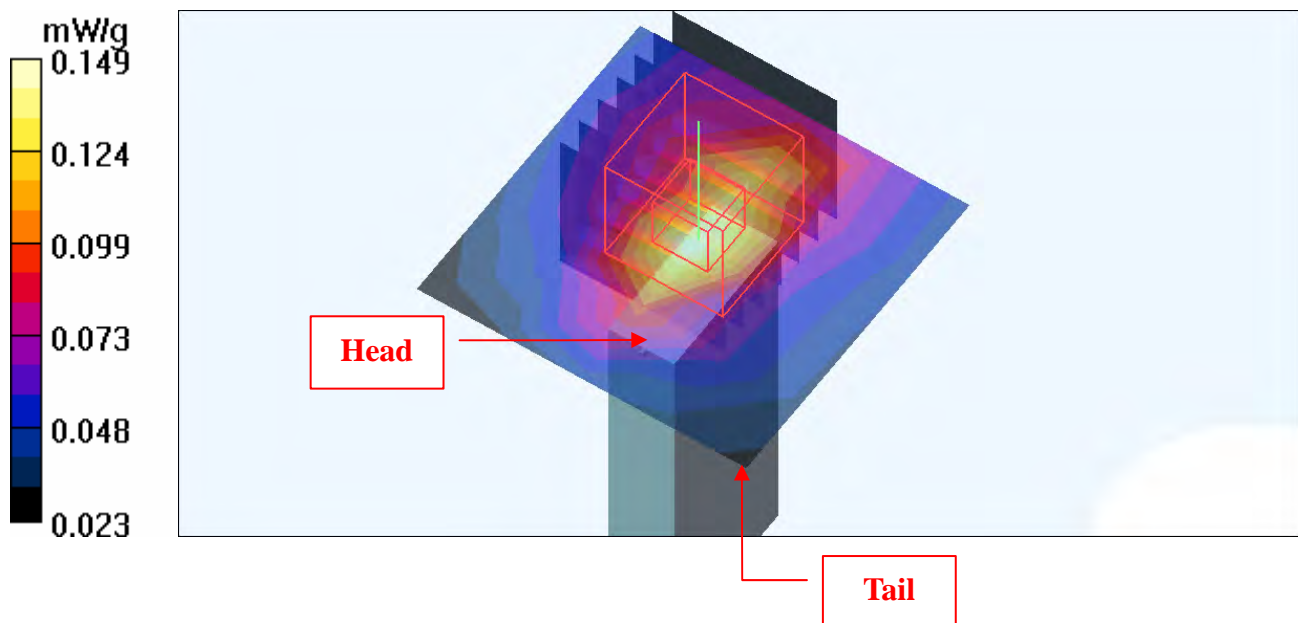

Test Laboratory: Bureau Veritas ADT

## M23-11g-Ch6

### DUT: Wireless N USB Adapter ; Type: DWA-130E1

Communication System: 802.11g ; Frequency: 2437 MHz ; Duty Cycle: 1:1 ; Modulation type: BPSK  
Medium: MSL2450 Medium parameters used:  $f = 2437$  MHz;  $\sigma = 1.96$  mho/m;  $\epsilon_r = 54.2$ ;  $\rho = 1000$  kg/m<sup>3</sup>  
Phantom section: Flat Section ; Separation distance : 5 mm (The tip side of the EUT to the Phantom)

#### DASY4 Configuration:

- Probe: EX3DV3 - SN3504 ; ConvF(7.53, 7.53, 7.53) ; Calibrated: 2009/1/21
- Sensor-Surface: 3mm (Mechanical Surface Detection)
- Electronics: DAE3 Sn510 ; Calibrated: 2009/1/21
- Phantom: SAM 12 ; Type: SAM V4.0 ; Serial: TP 1202
- Measurement SW: DASY4, V4.7 Build 80 ; Postprocessing SW: SEMCAD, V1.8 Build 186

#### Mid Channel 6/Area Scan (5x5x1): Measurement grid: dx=15mm, dy=15mm

Maximum value of SAR (measured) = 0.096 mW/g

#### Mid Channel 6/Zoom Scan (7x7x7) (7x7x7)/Cube 0: Measurement grid: dx=5mm, dy=5mm, dz=5mm

Reference Value = 6.99 V/m

Peak SAR (extrapolated) = 0.148 W/kg

SAR(1 g) = **0.076** mW/g; SAR(10 g) = 0.039 mW/g

Maximum value of SAR (measured) = 0.098 mW/g

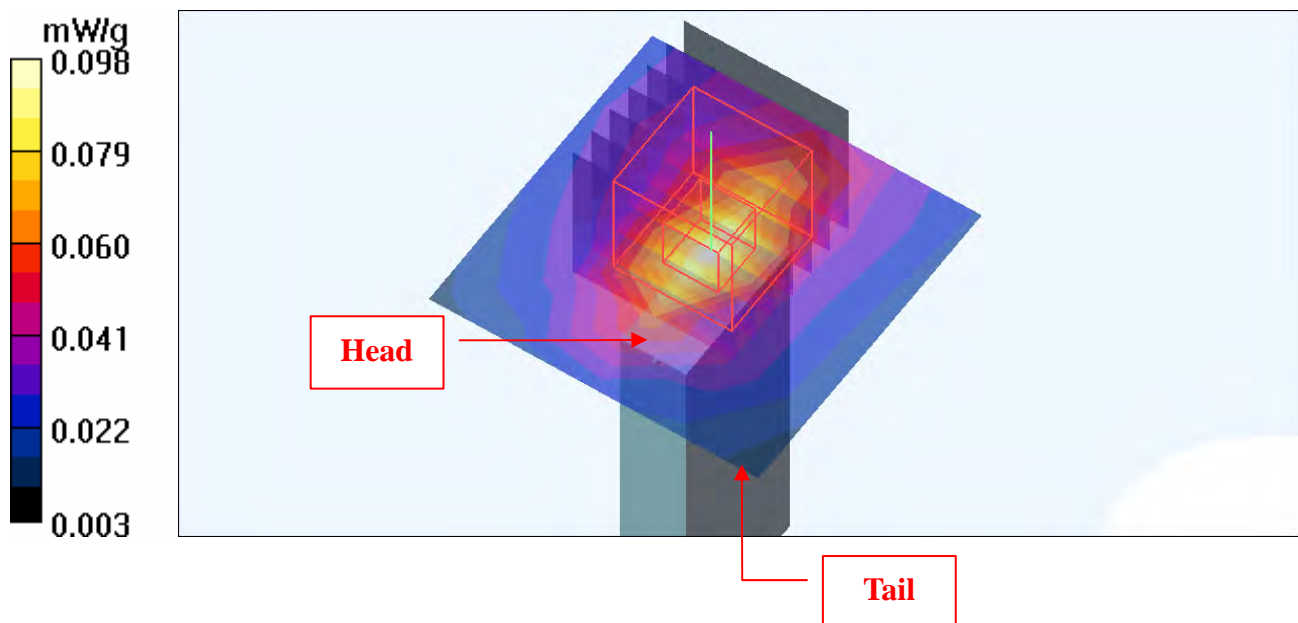

Test Laboratory: Bureau Veritas ADT

## M24-11N 20M-Ch6

### DUT: Wireless N USB Adapter ; Type: DWA-130E1

Communication System: 2.4G 11n span20 ; Frequency: 2437 MHz ; Duty Cycle: 1:1 ; Modulation type: BPSK

Medium: MSL2450 Medium parameters used:  $f = 2437$  MHz;  $\sigma = 1.96$  mho/m;  $\epsilon_r = 54.2$ ;  $\rho = 1000$  kg/m<sup>3</sup>  
Phantom section: Flat Section ; Separation distance : 5 mm (The tip side of the EUT to the Phantom)

DASY4 Configuration:

- Probe: EX3DV3 - SN3504 ; ConvF(7.53, 7.53, 7.53) ; Calibrated: 2009/1/21
- Sensor-Surface: 3mm (Mechanical Surface Detection)
- Electronics: DAE3 Sn510 ; Calibrated: 2009/1/21
- Phantom: SAM 12 ; Type: SAM V4.0 ; Serial: TP 1202
- Measurement SW: DASY4, V4.7 Build 80 ; Postprocessing SW: SEMCAD, V1.8 Build 186

**Mid Channel 6/Area Scan (5x5x1):** Measurement grid: dx=15mm, dy=15mm

Maximum value of SAR (measured) = 0.098 mW/g

**Mid Channel 6/Zoom Scan (7x7x7) (7x7x7)/Cube 0:** Measurement grid: dx=5mm, dy=5mm, dz=5mm

Reference Value = 7.13 V/m

Peak SAR (extrapolated) = 0.147 W/kg

**SAR(1 g) = 0.075 mW/g; SAR(10 g) = 0.038 mW/g**

Maximum value of SAR (measured) = 0.097 mW/g

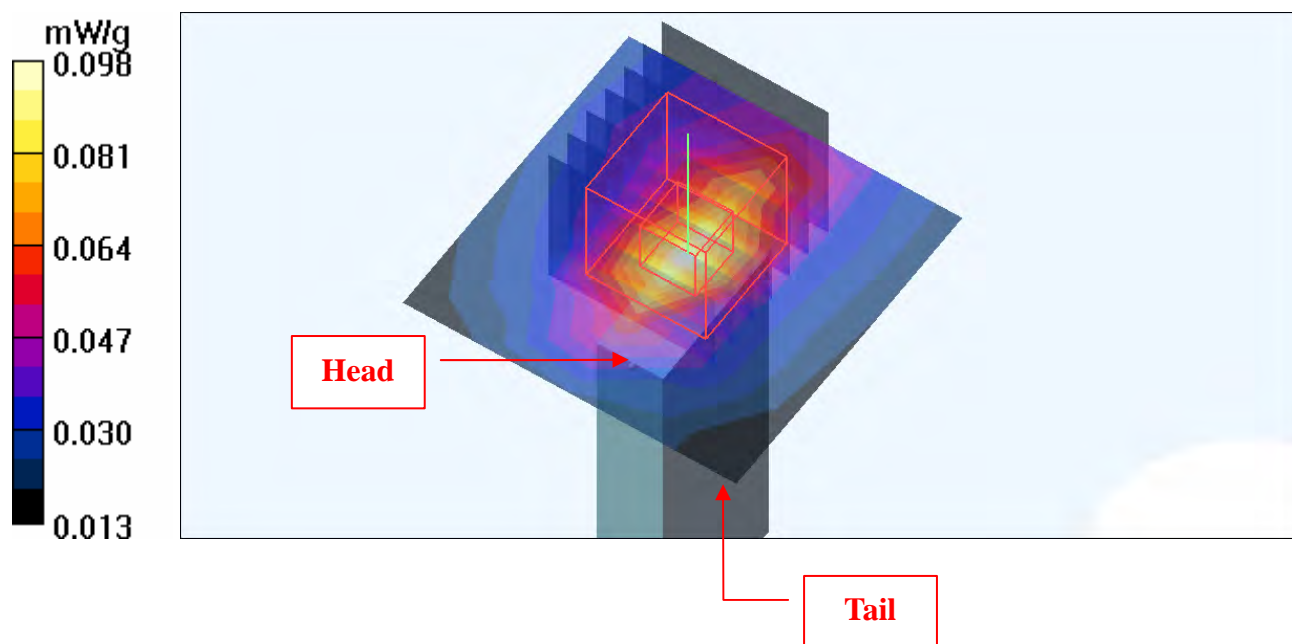

Test Laboratory: Bureau Veritas ADT

## M25-11N 40M-Ch4

### DUT: Wireless N USB Adapter ; Type: DWA-130E1

Communication System: 802.11n 40MHz ; Frequency: 2437 MHz ; Duty Cycle: 1:1 ; Modulation type: BPSK

Medium: MSL2450 Medium parameters used:  $f = 2437$  MHz;  $\sigma = 1.96$  mho/m;  $\epsilon_r = 54.2$ ;  $\rho = 1000$  kg/m<sup>3</sup>  
Phantom section: Flat Section ; Separation distance : 5 mm (The tip side of the EUT to the Phantom)

DASY4 Configuration:

- Probe: EX3DV3 - SN3504 ; ConvF(7.53, 7.53, 7.53) ; Calibrated: 2009/1/21
- Sensor-Surface: 3mm (Mechanical Surface Detection)
- Electronics: DAE3 Sn510 ; Calibrated: 2009/1/21
- Phantom: SAM 12 ; Type: SAM V4.0 ; Serial: TP 1202
- Measurement SW: DASY4, V4.7 Build 80 ; Postprocessing SW: SEMCAD, V1.8 Build 186

**Mid Channel 4/Area Scan (5x5x1):** Measurement grid: dx=15mm, dy=15mm

Maximum value of SAR (measured) = 0.075 mW/g

**Mid Channel 4/Zoom Scan (7x7x7) (7x7x7)/Cube 0:** Measurement grid: dx=5mm, dy=5mm, dz=5mm

Reference Value = 6.25 V/m

Peak SAR (extrapolated) = 0.113 W/kg

SAR(1 g) = **0.059** mW/g; SAR(10 g) = **0.030** mW/g

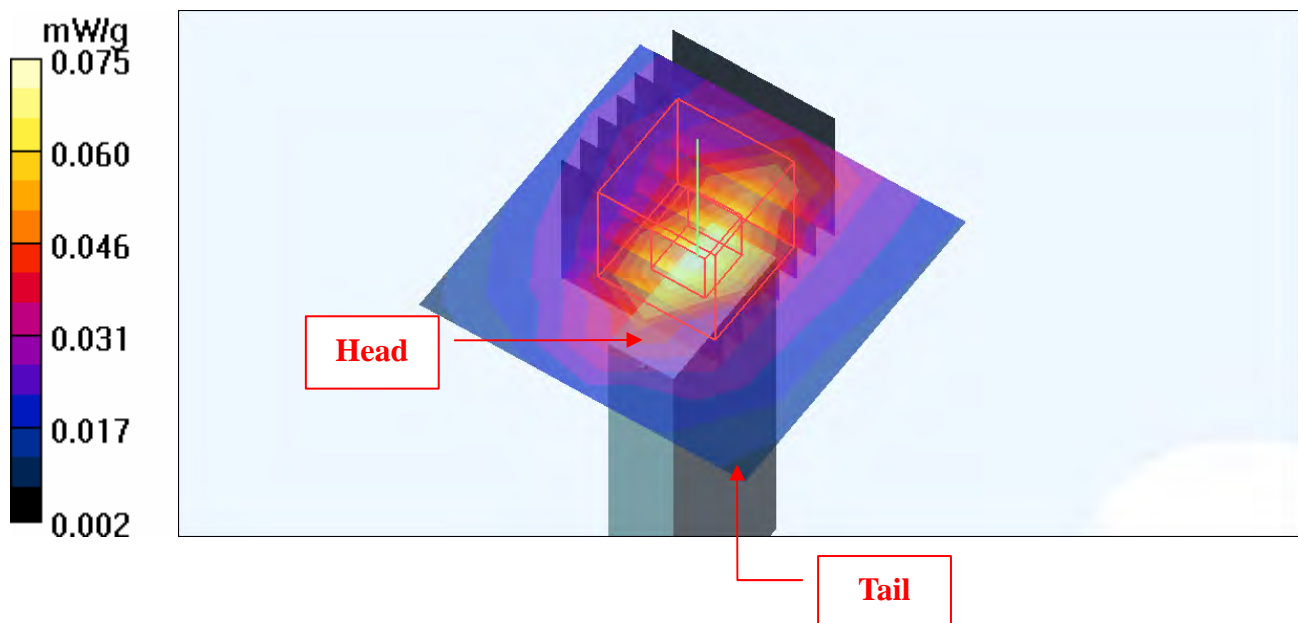

Test Laboratory: Bureau Veritas ADT

## M26-11b-Ch11

**DUT: Wireless N USB Adapter ; Type: DWA-130E1**

Communication System: 802.11b ; Frequency: 2462 MHz ; Duty Cycle: 1:1 ; Modulation type: DBPSK

Medium: MSL2450 Medium parameters used:  $f = 2462$  MHz;  $\sigma = 2$  mho/m;  $\epsilon_r = 54$ ;  $\rho = 1000$  kg/m<sup>3</sup>

Phantom section: Flat Section ; Separation distance : 5 mm (The bottom side of the EUT to the Phantom)

DASY4 Configuration:

- Probe: EX3DV3 - SN3504 ; ConvF(7.53, 7.53, 7.53) ; Calibrated: 2009/1/21
- Sensor-Surface: 2mm (Mechanical Surface Detection)
- Electronics: DAE3 Sn510 ; Calibrated: 2009/1/21
- Phantom: SAM 12 ; Type: SAM V4.0 ; Serial: TP 1202
- Measurement SW: DASY4, V4.7 Build 80 ; Postprocessing SW: SEMCAD, V1.8 Build 186

**High Channel 11/Area Scan (5x7x1):** Measurement grid: dx=15mm, dy=15mm

Maximum value of SAR (measured) = 0.914 mW/g

**High Channel 11/Zoom Scan (7x7x7) (13x13x13)/Cube 0:** Measurement grid: dx=2.5mm, dy=2.5mm, dz=2.5mm

Reference Value = 13.1 V/m

Peak SAR (extrapolated) = 1.50 W/kg

**SAR(1 g) = 0.676 mW/g; SAR(10 g) = 0.368 mW/g**

Maximum value of SAR (measured) = 1.03 mW/g

**High Channel 11/Zoom Scan (7x7x7) (13x13x13)/Cube 1:** Measurement grid: dx=2.5mm, dy=2.5mm, dz=2.5mm

Reference Value = 13.1 V/m

Peak SAR (extrapolated) = 1.35 W/kg

**SAR(1 g) = 0.662 mW/g; SAR(10 g) = 0.344 mW/g**

Maximum value of SAR (measured) = 0.994 mW/g

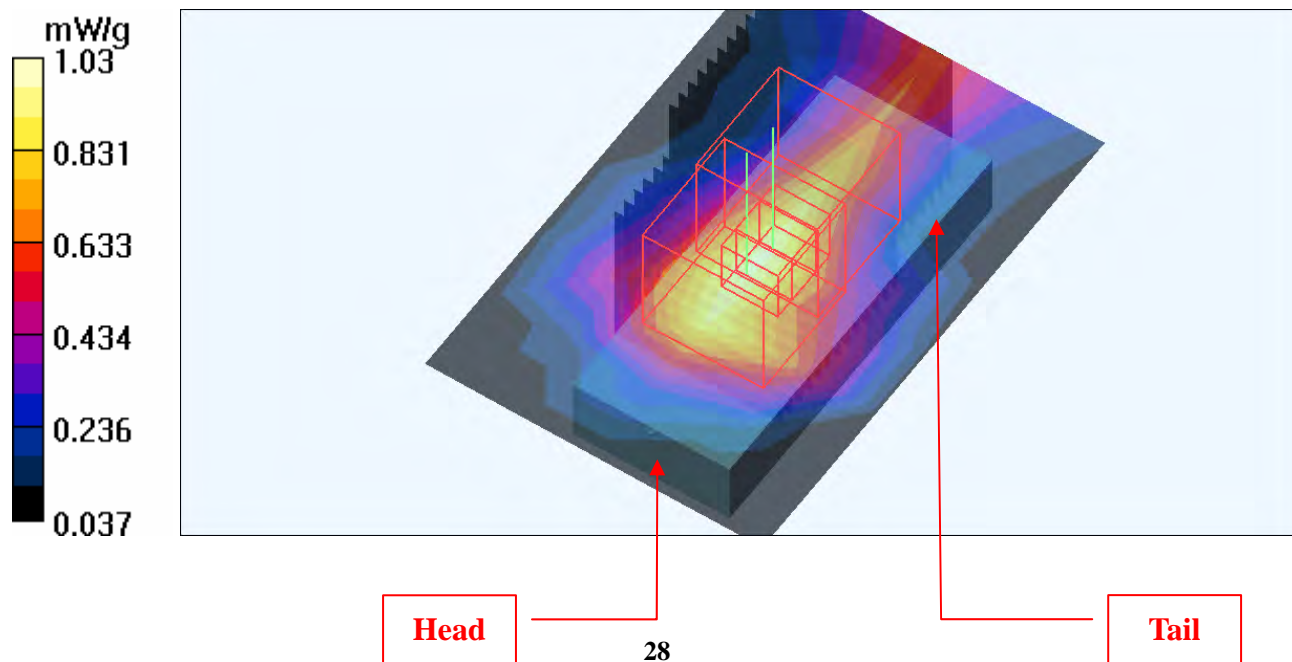

Test Laboratory: Bureau Veritas ADT

## System Validation Check-MSL 2450MHz

**DUT: Dipole 2450 MHz ; Type: D2450V2 ; Serial: 716 ; Test Frequency: 2450 MHz**

Communication System: CW ; Frequency: 2450 MHz; Duty Cycle: 1:1; Modulation type: CW  
Medium: MSL2450; Medium parameters used:  $f = 2450$  MHz;  $\sigma = 1.97$  mho/m;  $\epsilon_r = 54.1$ ;  $\rho = 1000$  kg/m<sup>3</sup> ; Liquid level : 150 mm  
Phantom section: Flat Section ; Separation distance : 10 mm (The feetpoint of the dipole to the Phantom) Air temp. : 23.5 degrees ; Liquid temp. : 22.2 degrees

### DASY4 Configuration:

- Probe: EX3DV3 - SN3504 ; ConvF(7.53, 7.53, 7.53) ; Calibrated: 2009/1/21
- Sensor-Surface: 3mm (Mechanical Surface Detection)
- Electronics: DAE3 Sn510; Calibrated: 2009/1/21
- Phantom: SAM 12; Type: SAM V4.0; Serial: TP 1202
- Measurement SW: DASY4, V4.7 Build 80; Postprocessing SW: SEMCAD, V1.8 Build 186

**d=10mm, Pin=250mW/Area Scan (5x7x1):** Measurement grid: dx=15mm, dy=15mm  
Maximum value of SAR (measured) = 17.8 mW/g

**d=10mm, Pin=250mW/Zoom Scan (7x7x7)/Cube 0:** Measurement grid: dx=5mm, dy=5mm, dz=5mm

Reference Value = 95.5 V/m; Power Drift = -0.050 dB

Peak SAR (extrapolated) = 28.8 W/kg

**SAR(1 g) = 13.3 mW/g; SAR(10 g) = 6.12 mW/g**

Maximum value of SAR (measured) = 17.9 mW/g

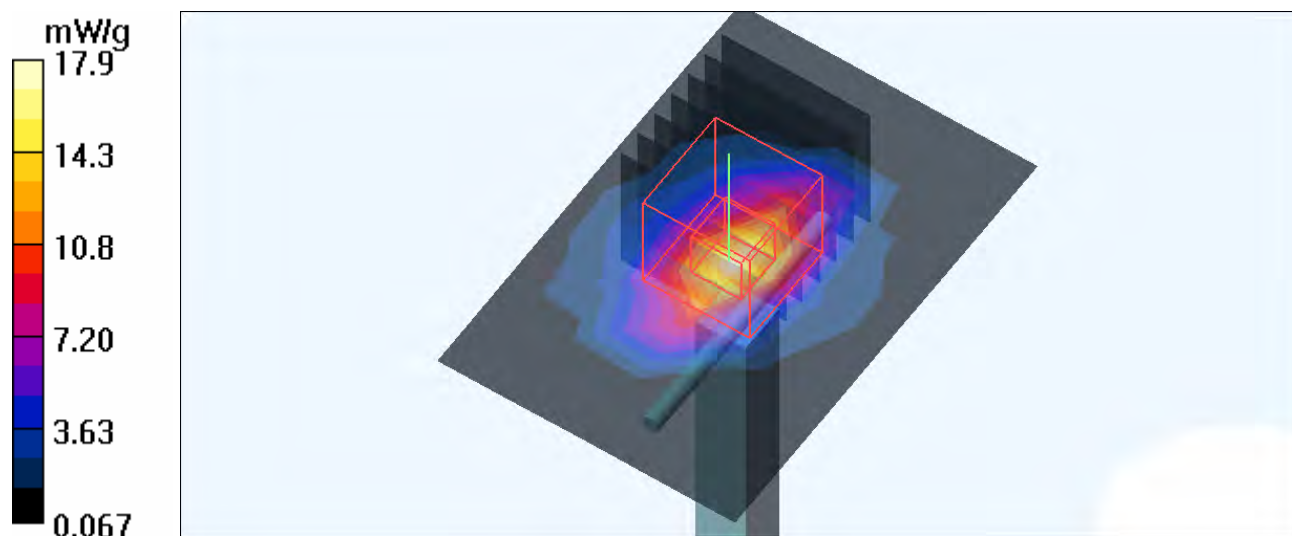

## APPENDIX B: ADT SAR MEASUREMENT SYSTEM



## APPENDIX C: PHOTOGRAPHS OF SYSTEM VALIDATION







## **APPENDIX D: SYSTEM CERTIFICATE & CALIBRATION**

### **D1: SAM PHANTOM**

# Schmid & Partner Engineering AG

Zeughausstrasse 43, 8004 Zurich, Switzerland, Phone +41 1 245 97 00, Fax +41 1 245 97 79

## Certificate of conformity / First Article Inspection

Item	SAM Twin Phantom V4.0
Type No	QD 000 P40 CA
Series No	TP-1150 and higher
Manufacturer / Origin	Untersee Composites Hauptstr. 69 CH-8559 Fruthwilen Switzerland

### Tests

The series production process used allows the limitation to test of first articles. Complete tests were made on the pre-series Type No. QD 000 P40 AA, Serial No. TP-1001 and on the series first article Type No. QD 000 P40 BA, Serial No. TP-1006. Certain parameters have been retested using further series units (called samples).

Test	Requirement	Details	Units tested
Shape	Compliance with the geometry according to the CAD model.	IT'IS CAD File (*)	First article, Samples
Material thickness	Compliant with the requirements according to the standards	2mm +/- 0.2mm in specific areas	First article, Samples
Material parameters	Dielectric parameters for required frequencies	200 MHz - 3 GHz Relative permittivity < 5 Loss tangent < 0.05.	Material sample TP 104-5
Material resistivity	The material has been tested to be compatible with the liquids defined in the standards	Liquid type HSL 1800 and others according to the standard.	Pre-series, First article

### Standards

- [1] CENELEC EN 50361
- [2] IEEE P1528-200x draft 6.5
- [3] IEC PT 62209 draft 0.9

(\*) The IT'IS CAD file is derived from [2] and is also within the tolerance requirements of the shapes of [1] and [3].

### Conformity

Based on the sample tests above, we certify that this item is in compliance with the uncertainty requirements of SAR measurements specified in standard [1] and draft standards [2] and [3].

Date

28.02.2002

Signature / Stamp

*F. Bumbult*

**Schmid & Partner  
Engineering AG**

Zeughausstrasse 43, CH-8004 Zurich  
Tel. +41 1 245 97 00, Fax +41 1 245 97 79

*Volker Kapp*



## D2: DOSIMETRIC E-FIELD PROBE



Accredited by the Swiss Accreditation Service (SAS)  
The Swiss Accreditation Service is one of the signatories to the EA  
Multilateral Agreement for the recognition of calibration certificates

Accreditation No.: **SCS 108**

Client **ADT (Auden)**

Certificate No: **EX3-3504\_Jan09**

## CALIBRATION CERTIFICATE

Object **EX3DV3 - SN:3504**

Calibration procedure(s) **QA CAL-01.v6, QA CAL-14.v3 and QA CAL-23.v3  
Calibration procedure for dosimetric E-field probes**

Calibration date: **January 21, 2009**

Condition of the calibrated item **In Tolerance**

This calibration certificate documents the traceability to national standards, which realize the physical units of measurements (SI).  
The measurements and the uncertainties with confidence probability are given on the following pages and are part of the certificate.

All calibrations have been conducted in the closed laboratory facility: environment temperature ( $22 \pm 3$ )°C and humidity < 70%.

Calibration Equipment used (M&TE critical for calibration)

Primary Standards	ID #	Cal Date (Certificate No.)	Scheduled Calibration
Power meter E4419B	GB41293874	1-Apr-08 (No. 217-00788)	Apr-09
Power sensor E4412A	MY41495277	1-Apr-08 (No. 217-00788)	Apr-09
Power sensor E4412A	MY41498087	1-Apr-08 (No. 217-00788)	Apr-09
Reference 3 dB Attenuator	SN: S5054 (3c)	1-Jul-08 (No. 217-00865)	Jul-09
Reference 20 dB Attenuator	SN: S5086 (20b)	31-Mar-08 (No. 217-00787)	Apr-09
Reference 30 dB Attenuator	SN: S5129 (30b)	1-Jul-08 (No. 217-00866)	Jul-09
Reference Probe ES3DV2	SN: 3013	2-Jan-09 (No. ES3-3013_Jan09)	Jan-10
DAE4	SN: 660	9-Sep-08 (No. DAE4-660_Sep08)	Sep-09
Secondary Standards	ID #	Check Date (in house)	Scheduled Check
RF generator HP 8648C	US3642U01700	4-Aug-99 (in house check Oct-07)	In house check: Oct-09
Network Analyzer HP 8753E	US37390585	18-Oct-01 (in house check Oct-08)	In house check: Oct-09

	Name	Function	Signature
Calibrated by:	Katja Pokovic	Technical Manager	
Approved by:	Niels Kuster	Quality Manager	

Issued: January 21, 2009

This calibration certificate shall not be reproduced except in full without written approval of the laboratory.



Accredited by the Swiss Accreditation Service (SAS)  
The Swiss Accreditation Service is one of the signatories to the EA  
Multilateral Agreement for the recognition of calibration certificates

Accreditation No.: **SCS 108**

### Glossary:

TSL	tissue simulating liquid
NORM <sub>x,y,z</sub>	sensitivity in free space
ConvF	sensitivity in TSL / NORM <sub>x,y,z</sub>
DCP	diode compression point
Polarization $\varphi$	$\varphi$ rotation around probe axis
Polarization $\vartheta$	$\vartheta$ rotation around an axis that is in the plane normal to probe axis (at measurement center), i.e., $\vartheta = 0$ is normal to probe axis

### Calibration is Performed According to the Following Standards:

- IEEE Std 1528-2003, "IEEE Recommended Practice for Determining the Peak Spatial-Averaged Specific Absorption Rate (SAR) in the Human Head from Wireless Communications Devices: Measurement Techniques", December 2003
- IEC 62209-1, "Procedure to measure the Specific Absorption Rate (SAR) for hand-held devices used in close proximity to the ear (frequency range of 300 MHz to 3 GHz)", February 2005

### Methods Applied and Interpretation of Parameters:

- NORM<sub>x,y,z</sub>**: Assessed for E-field polarization  $\vartheta = 0$  ( $f \leq 900$  MHz in TEM-cell;  $f > 1800$  MHz: R22 waveguide). NORM<sub>x,y,z</sub> are only intermediate values, i.e., the uncertainties of NORM<sub>x,y,z</sub> does not effect the E<sup>2</sup>-field uncertainty inside TSL (see below *ConvF*).
- NORM(*f*)<sub>x,y,z</sub>** = NORM<sub>x,y,z</sub> \* *frequency\_response* (see Frequency Response Chart). This linearization is implemented in DASY4 software versions later than 4.2. The uncertainty of the frequency response is included in the stated uncertainty of *ConvF*.
- DCP<sub>x,y,z</sub>**: DCP are numerical linearization parameters assessed based on the data of power sweep (no uncertainty required). DCP does not depend on frequency nor media.
- ConvF and Boundary Effect Parameters**: Assessed in flat phantom using E-field (or Temperature Transfer Standard for  $f \leq 800$  MHz) and inside waveguide using analytical field distributions based on power measurements for  $f > 800$  MHz. The same setups are used for assessment of the parameters applied for boundary compensation (alpha, depth) of which typical uncertainty values are given. These parameters are used in DASY4 software to improve probe accuracy close to the boundary. The sensitivity in TSL corresponds to NORM<sub>x,y,z</sub> \* *ConvF* whereby the uncertainty corresponds to that given for *ConvF*. A frequency dependent *ConvF* is used in DASY version 4.4 and higher which allows extending the validity from  $\pm 50$  MHz to  $\pm 100$  MHz.
- Spherical isotropy (3D deviation from isotropy)**: in a field of low gradients realized using a flat phantom exposed by a patch antenna.
- Sensor Offset**: The sensor offset corresponds to the offset of virtual measurement center from the probe tip (on probe axis). No tolerance required.

# Probe EX3DV3

## SN:3504

Manufactured:	December 15, 2003
Last calibrated:	August 30, 2007
Recalibrated:	January 21, 2009

Calibrated for DASY Systems

(Note: non-compatible with DASY2 system!)

## DASY - Parameters of Probe: EX3DV3 SN:3504

Sensitivity in Free Space <sup>A</sup>			Diode Compression <sup>B</sup>	
NormX	0.60 ± 10.1%	$\mu\text{V}/(\text{V}/\text{m})^2$	DCP X	94 mV
NormY	0.62 ± 10.1%	$\mu\text{V}/(\text{V}/\text{m})^2$	DCP Y	94 mV
NormZ	0.65 ± 10.1%	$\mu\text{V}/(\text{V}/\text{m})^2$	DCP Z	95 mV

### Sensitivity in Tissue Simulating Liquid (Conversion Factors)

Please see Page 8.

### Boundary Effect

TSL	900 MHz	Typical SAR gradient: 5 % per mm	
	Sensor Center to Phantom Surface Distance	2.0 mm	3.0 mm
	SAR <sub>be</sub> [%] Without Correction Algorithm	10.0	6.0
	SAR <sub>be</sub> [%] With Correction Algorithm	0.7	0.3
TSL	1750 MHz	Typical SAR gradient: 10 % per mm	
	Sensor Center to Phantom Surface Distance	2.0 mm	3.0 mm
	SAR <sub>be</sub> [%] Without Correction Algorithm	8.0	4.9
	SAR <sub>be</sub> [%] With Correction Algorithm	0.8	0.6

### Sensor Offset

Probe Tip to Sensor Center **1.0 mm**

The reported uncertainty of measurement is stated as the standard uncertainty of measurement multiplied by the coverage factor  $k=2$ , which for a normal distribution corresponds to a coverage probability of approximately 95%.

<sup>A</sup> The uncertainties of NormX,Y,Z do not affect the E<sup>2</sup>-field uncertainty inside TSL (see Page 8).

<sup>B</sup> Numerical linearization parameter: uncertainty not required.

# Frequency Response of E-Field

(TEM-Cell:ifi110 EXX, Waveguide: R22)

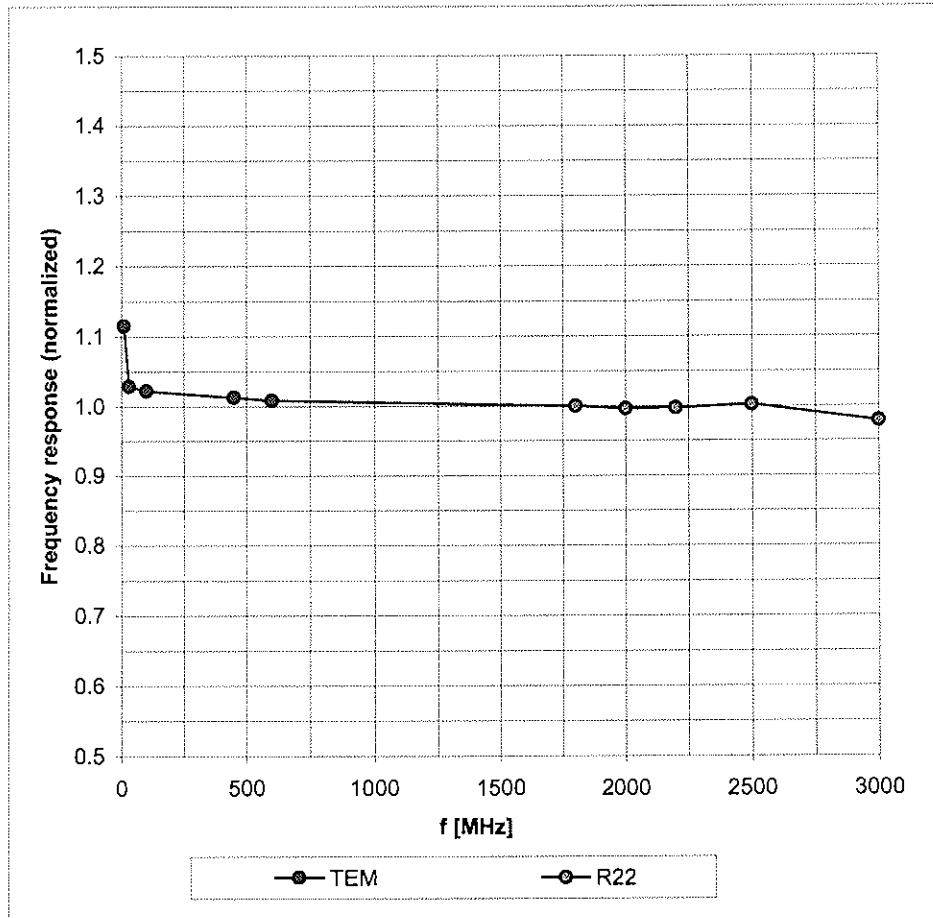

Uncertainty of Frequency Response of E-field:  $\pm 6.3\%$  ( $k=2$ )



### Receiving Pattern ( $\phi$ ), $\vartheta = 0^\circ$

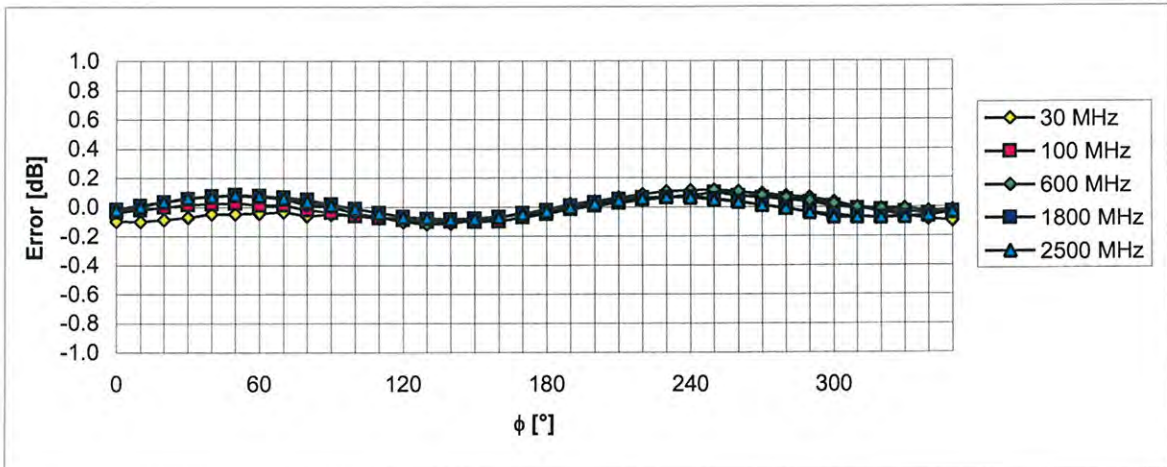
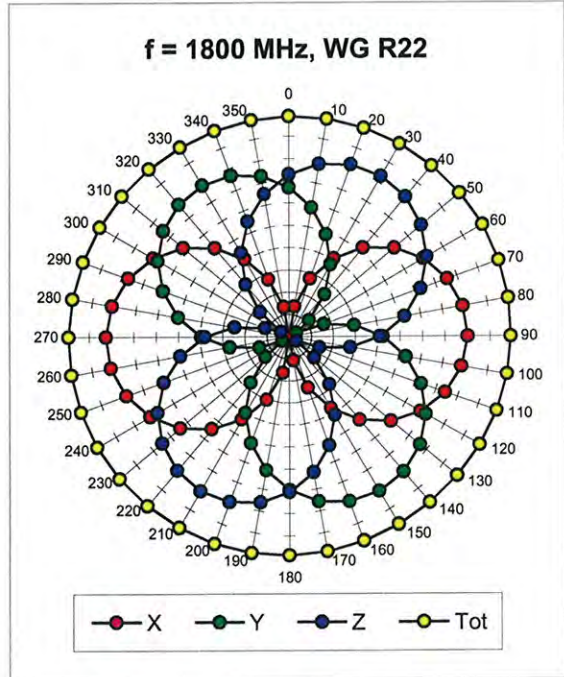
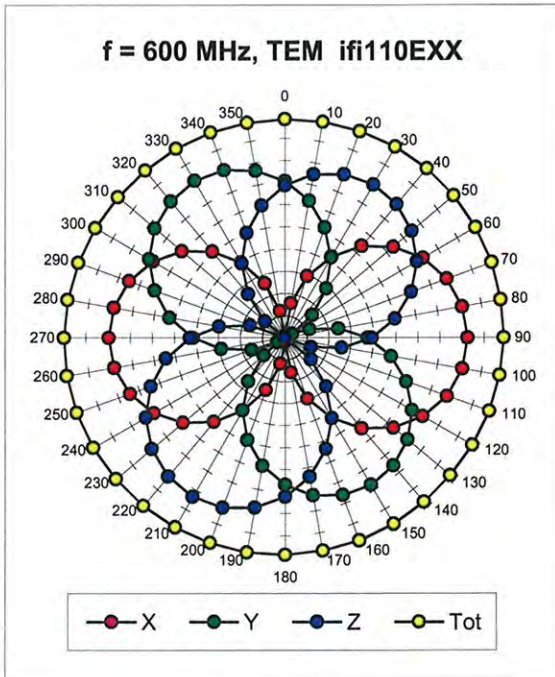

Uncertainty of Axial Isotropy Assessment:  $\pm 0.5\%$  ( $k=2$ )

## Dynamic Range f(SAR<sub>head</sub>)

(Waveguide R22, f = 1800 MHz)

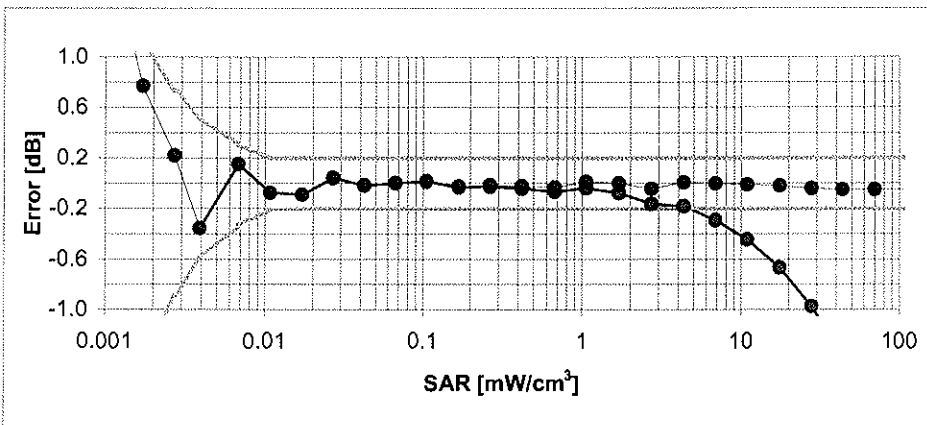
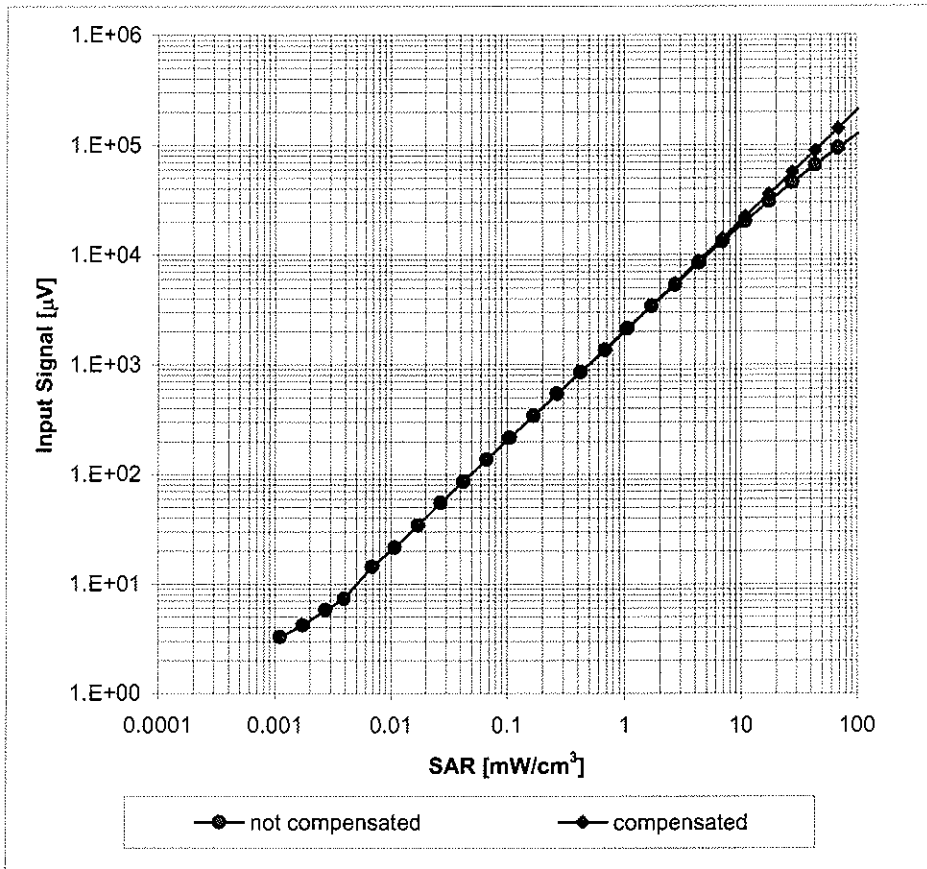

Uncertainty of Linearity Assessment: ± 0.6% (k=2)

## Conversion Factor Assessment

f [MHz]	Validity [MHz] <sup>c</sup>	TSL	Permittivity	Conductivity	Alpha	Depth	ConvF Uncertainty
900	± 50 / ± 100	Head	41.5 ± 5%	0.97 ± 5%	0.74	0.65	9.57 ± 11.0% (k=2)
1750	± 50 / ± 100	Head	40.1 ± 5%	1.37 ± 5%	0.56	0.64	8.53 ± 11.0% (k=2)
1950	± 50 / ± 100	Head	40.0 ± 5%	1.40 ± 5%	0.76	0.57	8.08 ± 11.0% (k=2)
2450	± 50 / ± 100	Head	39.2 ± 5%	1.80 ± 5%	0.53	0.66	7.67 ± 11.0% (k=2)
2600	± 50 / ± 100	Head	39.0 ± 5%	1.96 ± 5%	0.24	0.98	7.56 ± 11.0% (k=2)
5200	± 50 / ± 100	Head	36.0 ± 5%	4.66 ± 5%	0.42	1.70	4.65 ± 13.1% (k=2)
5300	± 50 / ± 100	Head	35.9 ± 5%	4.76 ± 5%	0.42	1.70	4.49 ± 13.1% (k=2)
5500	± 50 / ± 100	Head	35.6 ± 5%	4.96 ± 5%	0.42	1.70	4.39 ± 13.1% (k=2)
5600	± 50 / ± 100	Head	35.5 ± 5%	5.07 ± 5%	0.42	1.70	4.29 ± 13.1% (k=2)
5800	± 50 / ± 100	Head	35.3 ± 5%	5.27 ± 5%	0.42	1.70	4.40 ± 13.1% (k=2)
900	± 50 / ± 100	Body	55.0 ± 5%	1.05 ± 5%	0.50	0.73	9.71 ± 11.0% (k=2)
1750	± 50 / ± 100	Body	53.4 ± 5%	1.49 ± 5%	0.46	0.73	8.36 ± 11.0% (k=2)
1950	± 50 / ± 100	Body	53.3 ± 5%	1.52 ± 5%	0.43	0.73	8.21 ± 11.0% (k=2)
2450	± 50 / ± 100	Body	52.7 ± 5%	1.95 ± 5%	0.27	1.07	7.53 ± 11.0% (k=2)
2600	± 50 / ± 100	Body	52.5 ± 5%	2.16 ± 5%	0.25	1.10	7.33 ± 11.0% (k=2)
5200	± 50 / ± 100	Body	49.0 ± 5%	5.30 ± 5%	0.45	1.75	4.38 ± 13.1% (k=2)
5300	± 50 / ± 100	Body	48.9 ± 5%	5.42 ± 5%	0.45	1.75	4.06 ± 13.1% (k=2)
5500	± 50 / ± 100	Body	48.6 ± 5%	5.65 ± 5%	0.42	1.75	3.98 ± 13.1% (k=2)
5600	± 50 / ± 100	Body	48.5 ± 5%	5.77 ± 5%	0.42	1.75	3.91 ± 13.1% (k=2)
5800	± 50 / ± 100	Body	48.2 ± 5%	6.00 ± 5%	0.42	1.75	3.98 ± 13.1% (k=2)

<sup>c</sup> The validity of ± 100 MHz only applies for DASY v4.4 and higher (see Page 2). The uncertainty is the RSS of the ConvF uncertainty at calibration frequency and the uncertainty for the indicated frequency band.

### Deviation from Isotropy in HSL

Error ( $\phi$ ,  $\theta$ ),  $f = 900$  MHz

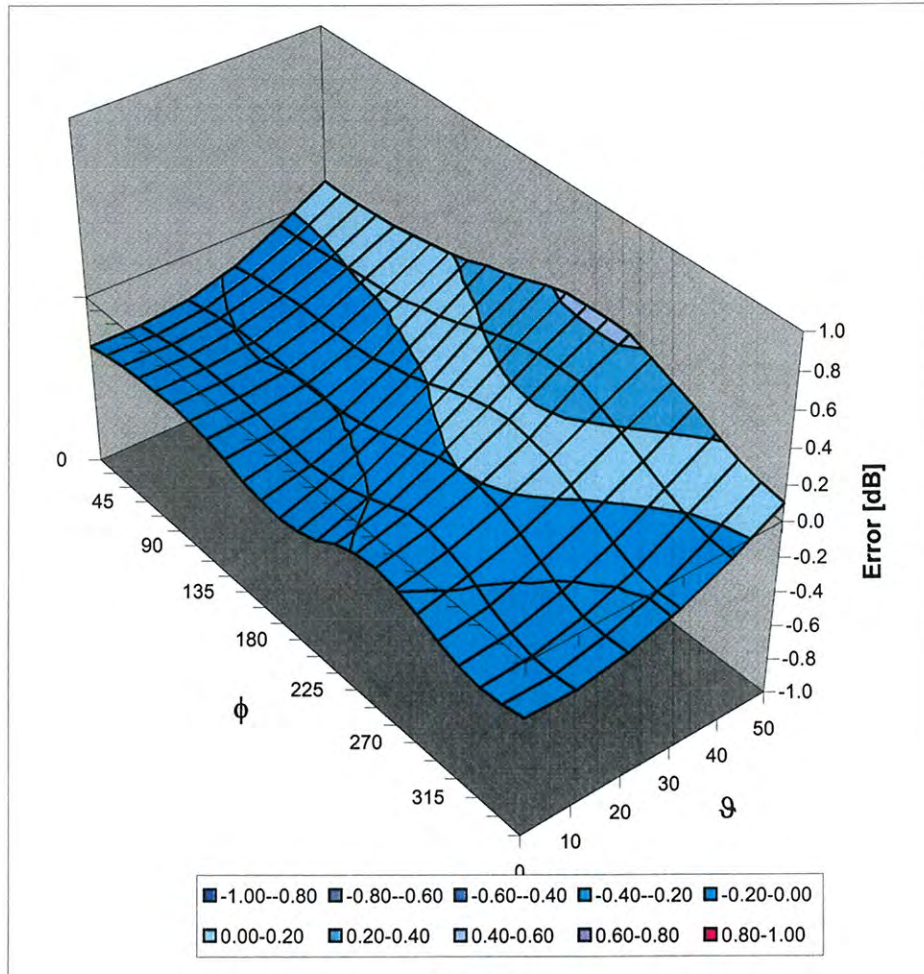

Uncertainty of Spherical Isotropy Assessment:  $\pm 2.6\%$  ( $k=2$ )



**D3: DAE**

## **IMPORTANT NOTICE**

### **USAGE OF THE DAE 3**

The DAE unit is a delicate, high precision instrument and requires careful treatment by the user. There are no serviceable parts inside the DAE. Special attention shall be given to the following points:

**Battery Exchange:** The battery cover of the DAE3 unit is connected to a fragile 3-pin battery connector. Customer is responsible to apply utmost caution not to bend or damage the connector when changing batteries.

**Shipping of the DAE:** Before shipping the DAE to SPEAG for calibration the customer shall remove the batteries and pack the DAE in an antistatic bag. This antistatic bag shall then be packed into a larger box or container which protects the DAE from impacts transportation. The package shall be marked to indicate that a fragile instrument is inside.

**E-Stop Failures:** Touch detection may be malfunctioning due to broken magnets in the E-stop. Rough handling of the E-stop may lead to damage of these magnets. Touch and collision errors are often caused by dust and dirt accumulated in the E-stop. To prevent E-stop failure, Customer shall always mount the probe to the DAE carefully and keep the DAE unit in a non-dusty environment if not used for measurements.

**Repair:** Minor repairs are performed at no extra cost during the annual calibration. However, SPEAG reserves the right to charge for any repair especially if rough unprofessional handling caused the defect.

**Important Note:**

**Warranty and calibration is void if the DAE unit is disassembled partly or fully by the Customer.**

**Important Note:**

**Never attempt to grease or oil the E-stop assembly. Cleaning and readjusting of the E-stop assembly is allowed by certified SPEAG personnel only and is part of the annual calibration procedure.**

**Important Note:**

**To prevent damage of the DAE probe connector pins, use great care when installing the probe to the DAE. Carefully connect the probe with the connector notch oriented in the mating position. Avoid any rotational movement of the probe body versus the DAE while turning the locking nut of the connector. The same care shall be used when disconnecting the probe from the DAE.**



Accredited by the Swiss Accreditation Service (SAS)  
The Swiss Accreditation Service is one of the signatories to the EA  
Multilateral Agreement for the recognition of calibration certificates

Accreditation No.: **SCS 108**

Client **ADT (Auden)**

Certificate No: **DAE3-510\_Jan09**

## CALIBRATION CERTIFICATE

Object **DAE3 - SD 000 D03 AA - SN: 510**

Calibration procedure(s) **QA CAL-06.v12  
Calibration procedure for the data acquisition electronics (DAE)**

Calibration date: **January 21, 2009**

Condition of the calibrated item **In Tolerance**

This calibration certificate documents the traceability to national standards, which realize the physical units of measurements (SI).  
The measurements and the uncertainties with confidence probability are given on the following pages and are part of the certificate.

All calibrations have been conducted in the closed laboratory facility: environment temperature  $(22 \pm 3)^\circ\text{C}$  and humidity  $< 70\%$ .

Calibration Equipment used (M&TE critical for calibration)

Primary Standards	ID #	Cal Date (Certificate No.)	Scheduled Calibration
Fluke Process Calibrator Type 702	SN: 6295803	30-Sep-08 (No: 7673)	Sep-09
Keithley Multimeter Type 2001	SN: 0810278	30-Sep-08 (No: 7670)	Sep-09
Secondary Standards	ID #	Check Date (in house)	Scheduled Check
Calibrator Box V1.1	SE UMS 006 AB 1004	06-Jun-08 (in house check)	In house check: Jun-09

	Name	Function	Signature
Calibrated by:	Eric Hainfeld	Technician	
Approved by:	Fin Bomholt	R&D Director	

Issued: January 21, 2009

This calibration certificate shall not be reproduced except in full without written approval of the laboratory.



Accredited by the Swiss Accreditation Service (SAS)  
The Swiss Accreditation Service is one of the signatories to the EA  
Multilateral Agreement for the recognition of calibration certificates

Accreditation No.: **SCS 108**

## Glossary

**DAE** data acquisition electronics  
**Connector angle** information used in DASY system to align probe sensor X to the robot coordinate system.

## Methods Applied and Interpretation of Parameters

- *DC Voltage Measurement:* Calibration Factor assessed for use in DASY system by comparison with a calibrated instrument traceable to national standards. The figure given corresponds to the full scale range of the voltmeter in the respective range.
- *Connector angle:* The angle of the connector is assessed measuring the angle mechanically by a tool inserted. Uncertainty is not required.
- The following parameters as documented in the Appendix contain technical information as a result from the performance test and require no uncertainty.
  - *DC Voltage Measurement Linearity:* Verification of the Linearity at +10% and -10% of the nominal calibration voltage. Influence of offset voltage is included in this measurement.
  - *Common mode sensitivity:* Influence of a positive or negative common mode voltage on the differential measurement.
  - *Channel separation:* Influence of a voltage on the neighbor channels not subject to an input voltage.
  - *AD Converter Values with inputs shorted:* Values on the internal AD converter corresponding to zero input voltage
  - *Input Offset Measurement:* Output voltage and statistical results over a large number of zero voltage measurements.
  - *Input Offset Current:* Typical value for information; Maximum channel input offset current, not considering the input resistance.
  - *Input resistance:* DAE input resistance at the connector, during internal auto-zeroing and during measurement.
  - *Low Battery Alarm Voltage:* Typical value for information. Below this voltage, a battery alarm signal is generated.
  - *Power consumption:* Typical value for information. Supply currents in various operating modes.



## DC Voltage Measurement

A/D - Converter Resolution nominal

High Range: 1LSB = 6.1 $\mu$ V, full range = -100...+300 mV

Low Range: 1LSB = 61nV, full range = -1.....+3mV

DASY measurement parameters: Auto Zero Time: 3 sec; Measuring time: 3 sec

Calibration Factors	X	Y	Z
High Range	404.180 $\pm$ 0.1% (k=2)	404.237 $\pm$ 0.1% (k=2)	404.597 $\pm$ 0.1% (k=2)
Low Range	3.98584 $\pm$ 0.7% (k=2)	3.96418 $\pm$ 0.7% (k=2)	3.97982 $\pm$ 0.7% (k=2)

## Connector Angle

Connector Angle to be used in DASY system	42 $^{\circ}$ $\pm$ 1 $^{\circ}$
---	----------------------------------

## Appendix

### 1. DC Voltage Linearity

High Range		Input ( $\mu\text{V}$ )	Reading ( $\mu\text{V}$ )	Error (%)
Channel X	+ Input	200000	200000.4	0.00
Channel X	+ Input	20000	20006.50	0.03
Channel X	- Input	20000	-20001.19	0.01
Channel Y	+ Input	200000	200000	0.00
Channel Y	+ Input	20000	20006.34	0.03
Channel Y	- Input	20000	-19999.47	0.00
Channel Z	+ Input	200000	200000.4	0.00
Channel Z	+ Input	20000	20005.85	0.03
Channel Z	- Input	20000	-20001.94	0.01

Low Range		Input ( $\mu\text{V}$ )	Reading ( $\mu\text{V}$ )	Error (%)
Channel X	+ Input	2000	2000.1	0.00
Channel X	+ Input	200	200.26	0.13
Channel X	- Input	200	-200.29	0.14
Channel Y	+ Input	2000	1999.9	0.00
Channel Y	+ Input	200	199.55	-0.22
Channel Y	- Input	200	-200.78	0.39
Channel Z	+ Input	2000	2000	0.00
Channel Z	+ Input	200	199.35	-0.32
Channel Z	- Input	200	-200.86	0.43

### 2. Common mode sensitivity

DASY measurement parameters: Auto Zero Time: 3 sec; Measuring time: 3 sec

	Common mode Input Voltage (mV)	High Range Average Reading ( $\mu\text{V}$ )	Low Range Average Reading ( $\mu\text{V}$ )
Channel X	200	17.77	16.87
	- 200	-15.55	-16.83
Channel Y	200	16.07	14.66
	- 200	-15.10	-16.55
Channel Z	200	-7.41	-8.67
	- 200	8.31	7.63

### 3. Channel separation

DASY measurement parameters: Auto Zero Time: 3 sec; Measuring time: 3 sec

	Input Voltage (mV)	Channel X ( $\mu\text{V}$ )	Channel Y ( $\mu\text{V}$ )	Channel Z ( $\mu\text{V}$ )
Channel X	200	-	2.33	0.92
Channel Y	200	0.91	-	2.64
Channel Z	200	-1.49	0.24	-

#### 4. AD-Converter Values with inputs shorted

DASY measurement parameters: Auto Zero Time: 3 sec; Measuring time: 3 sec

	High Range (LSB)	Low Range (LSB)
Channel X	15922	16220
Channel Y	16083	15853
Channel Z	16077	16696

#### 5. Input Offset Measurement

DASY measurement parameters: Auto Zero Time: 3 sec; Measuring time: 3 sec

Input 10M $\Omega$

	Average ( $\mu$ V)	min. Offset ( $\mu$ V)	max. Offset ( $\mu$ V)	Std. Deviation ( $\mu$ V)
Channel X	0.06	-0.34	0.80	0.21
Channel Y	-1.04	-1.65	0.01	0.25
Channel Z	0.59	-0.07	2.82	0.30

#### 6. Input Offset Current

Nominal Input circuitry offset current on all channels: <25fA

#### 7. Input Resistance

	Zeroing (MOhm)	Measuring (MOhm)
Channel X	0.2001	199.1
Channel Y	0.2001	197.8
Channel Z	0.2001	199.1

#### 8. Low Battery Alarm Voltage (verified during pre test)

Typical values	Alarm Level (VDC)
Supply (+ Vcc)	+7.9
Supply (- Vcc)	-7.6

#### 9. Power Consumption (verified during pre test)

Typical values	Switched off (mA)	Stand by (mA)	Transmitting (mA)
Supply (+ Vcc)	+0.0	+6	+14
Supply (- Vcc)	-0.01	-8	-9



## D4: SYSTEM VALIDATION DIPOLE



Accredited by the Swiss Accreditation Service (SAS)  
The Swiss Accreditation Service is one of the signatories to the EA  
Multilateral Agreement for the recognition of calibration certificates

Accreditation No.: **SCS 108**

Client **BV-ADT (Auden)**

Certificate No: **D2450V2-716\_Mar09**

## CALIBRATION CERTIFICATE

Object **D2450V2 - SN: 716**

Calibration procedure(s) **QA CAL-05.v7  
Calibration procedure for dipole validation kits**

Calibration date: **March 17, 2009**

Condition of the calibrated item **In Tolerance**

This calibration certificate documents the traceability to national standards, which realize the physical units of measurements (SI).  
The measurements and the uncertainties with confidence probability are given on the following pages and are part of the certificate.

All calibrations have been conducted in the closed laboratory facility: environment temperature ( $22 \pm 3$ )°C and humidity < 70%.

Calibration Equipment used (M&TE critical for calibration)

Primary Standards	ID #	Cal Date (Calibrated by, Certificate No.)	Scheduled Calibration
Power meter EPM-442A	GB37480704	08-Oct-08 (No. 217-00898)	Oct-09
Power sensor HP 8481A	US37292783	08-Oct-08 (No. 217-00898)	Oct-09
Reference 20 dB Attenuator	SN: 5086 (20g)	01-Jul-08 (No. 217-00864)	Jul-09
Type-N mismatch combination	SN: 5047.2 / 06327	01-Jul-08 (No. 217-00867)	Jul-09
Reference Probe ES3DV2	SN: 3025	28-Apr-08 (No. ES3-3025_Apr08)	Apr-09
DAE4	SN: 601	07-Mar-09 (No. DAE4-601_Mar09)	Mar-10
Secondary Standards	ID #	Check Date (in house)	Scheduled Check
Power sensor HP 8481A	MY41092317	18-Oct-02 (in house check Oct-07)	In house check: Oct-09
RF generator R&S SMT-06	100005	4-Aug-99 (in house check Oct-07)	In house check: Oct-09
Network Analyzer HP 8753E	US37390585 S4206	18-Oct-01 (in house check Oct-08)	In house check: Oct-09

Calibrated by: **Jeton Kastrati**      **Laboratory Technician**

Approved by: **Katja Pokovic**      **Technical Manager**

Signature

Issued: March 18, 2009

This calibration certificate shall not be reproduced except in full without written approval of the laboratory.



Accredited by the Swiss Accreditation Service (SAS)  
The Swiss Accreditation Service is one of the signatories to the EA  
Multilateral Agreement for the recognition of calibration certificates

Accreditation No.: **SCS 108**

### Glossary:

TSL	tissue simulating liquid
ConvF	sensitivity in TSL / NORM x,y,z
N/A	not applicable or not measured

### Calibration is Performed According to the Following Standards:

- IEEE Std 1528-2003, "IEEE Recommended Practice for Determining the Peak Spatial-Averaged Specific Absorption Rate (SAR) in the Human Head from Wireless Communications Devices: Measurement Techniques", December 2003
- IEC 62209-1, "Procedure to measure the Specific Absorption Rate (SAR) for hand-held devices used in close proximity to the ear (frequency range of 300 MHz to 3 GHz)", February 2005
- Federal Communications Commission Office of Engineering & Technology (FCC OET), "Evaluating Compliance with FCC Guidelines for Human Exposure to Radiofrequency Electromagnetic Fields; Additional Information for Evaluating Compliance of Mobile and Portable Devices with FCC Limits for Human Exposure to Radiofrequency Emissions", Supplement C (Edition 01-01) to Bulletin 65

### Additional Documentation:

- DASY4/5 System Handbook

### Methods Applied and Interpretation of Parameters:

- Measurement Conditions:** Further details are available from the Validation Report at the end of the certificate. All figures stated in the certificate are valid at the frequency indicated.
- Antenna Parameters with TSL:** The dipole is mounted with the spacer to position its feed point exactly below the center marking of the flat phantom section, with the arms oriented parallel to the body axis.
- Feed Point Impedance and Return Loss:** These parameters are measured with the dipole positioned under the liquid filled phantom. The impedance stated is transformed from the measurement at the SMA connector to the feed point. The Return Loss ensures low reflected power. No uncertainty required.
- Electrical Delay:** One-way delay between the SMA connector and the antenna feed point. No uncertainty required.
- SAR measured:** SAR measured at the stated antenna input power.
- SAR normalized:** SAR as measured, normalized to an input power of 1 W at the antenna connector.
- SAR for nominal TSL parameters:** The measured TSL parameters are used to calculate the nominal SAR result.

## Measurement Conditions

DASY system configuration, as far as not given on page 1.

<b>DASY Version</b>	DASY5	V5.0
<b>Extrapolation</b>	Advanced Extrapolation	
<b>Phantom</b>	Modular Flat Phantom V5.0	
<b>Distance Dipole Center - TSL</b>	10 mm	with Spacer
<b>Zoom Scan Resolution</b>	dx, dy, dz = 5 mm	
<b>Frequency</b>	2450 MHz $\pm$ 1 MHz	

## Head TSL parameters

The following parameters and calculations were applied.

	Temperature	Permittivity	Conductivity
<b>Nominal Head TSL parameters</b>	22.0 °C	39.2	1.80 mho/m
<b>Measured Head TSL parameters</b>	(22.0 $\pm$ 0.2) °C	38.0 $\pm$ 6 %	1.82 mho/m $\pm$ 6 %
<b>Head TSL temperature during test</b>	(21.0 $\pm$ 0.2) °C	----	----

## SAR result with Head TSL

<b>SAR averaged over 1 cm<sup>3</sup> (1 g) of Head TSL</b>	Condition	
SAR measured	250 mW input power	13.5 mW / g
SAR normalized	normalized to 1W	54.0 mW / g
<b>SAR for nominal Head TSL parameters <sup>1</sup></b>	normalized to 1W	<b>53.3 mW / g <math>\pm</math> 17.0 % (k=2)</b>

<b>SAR averaged over 10 cm<sup>3</sup> (10 g) of Head TSL</b>	condition	
SAR measured	250 mW input power	6.24 mW / g
SAR normalized	normalized to 1W	25.0 mW / g
<b>SAR for nominal Head TSL parameters <sup>1</sup></b>	normalized to 1W	<b>24.8 mW / g <math>\pm</math> 16.5 % (k=2)</b>

<sup>1</sup> Correction to nominal TSL parameters according to d), chapter "SAR Sensitivities"

## Body TSL parameters

The following parameters and calculations were applied.

	Temperature	Permittivity	Conductivity
Nominal Body TSL parameters	22.0 °C	52.7	1.95 mho/m
Measured Body TSL parameters	(22.0 ± 0.2) °C	54.3 ± 6 %	1.99 mho/m ± 6 %
Body TSL temperature during test	(21.1 ± 0.2) °C	----	----

## SAR result with Body TSL

SAR averaged over 1 cm <sup>3</sup> (1 g) of Body TSL	Condition	
SAR measured	250 mW input power	13.3 mW / g
SAR normalized	normalized to 1W	53.2 mW / g
SAR for nominal Body TSL parameters <sup>2</sup>	normalized to 1W	<b>52.9 mW / g ± 17.0 % (k=2)</b>

SAR averaged over 10 cm <sup>3</sup> (10 g) of Body TSL	condition	
SAR measured	250 mW input power	6.24 mW / g
SAR normalized	normalized to 1W	25.0 mW / g
SAR for nominal Body TSL parameters <sup>2</sup>	normalized to 1W	<b>25.0 mW / g ± 16.5 % (k=2)</b>

<sup>2</sup> Correction to nominal TSL parameters according to d), chapter "SAR Sensitivities"



## Appendix

### Antenna Parameters with Head TSL

Impedance, transformed to feed point	$54.9 \Omega + 1.4 j\Omega$
Return Loss	- 26.2 dB

### Antenna Parameters with Body TSL

Impedance, transformed to feed point	$50.2 \Omega + 4.3 j\Omega$
Return Loss	- 27.4 dB

### General Antenna Parameters and Design

Electrical Delay (one direction)	1.144 ns
----------------------------------	----------

After long term use with 100W radiated power, only a slight warming of the dipole near the feedpoint can be measured.

The dipole is made of standard semirigid coaxial cable. The center conductor of the feeding line is directly connected to the second arm of the dipole. The antenna is therefore short-circuited for DC-signals.

No excessive force must be applied to the dipole arms, because they might bend or the soldered connections near the feedpoint may be damaged.

### Additional EUT Data

Manufactured by	SPEAG
Manufactured on	September 10, 2002

## DASY5 Validation Report for Head TSL

Date/Time: 17.03.2009 15:42:29

Test Laboratory: SPEAG, Zurich, Switzerland

**DUT: Dipole 2450 MHz; Type: D2450V2; Serial: D2450V2 - SN716**

Communication System: CW; Frequency: 2450 MHz; Duty Cycle: 1:1

Medium: HSL U10 BB

Medium parameters used:  $f = 2450$  MHz;  $\sigma = 1.83$  mho/m;  $\epsilon_r = 38.1$ ;  $\rho = 1000$  kg/m<sup>3</sup>

Phantom section: Flat Section

Measurement Standard: DASY5 (IEEE/IEC)

DASY5 Configuration:

- Probe: ES3DV2 - SN3025; ConvF(4.4, 4.4, 4.4); Calibrated: 28.04.2008
- Sensor-Surface: 3.4mm (Mechanical Surface Detection)
- Electronics: DAE4 Sn601; Calibrated: 07.03.2009
- Phantom: Flat Phantom 5.0 (front); Type: QD000P50AA; Serial: 1001
- Measurement SW: DASY5, V5.0 Build 120; SEMCAD X Version 13.4 Build 45

**Pin = 250 mW; d = 10 mm/Zoom Scan (7x7x7)/Cube 0:** Measurement grid: dx=5mm, dy=5mm, dz=5mm

Reference Value = 96.5 V/m; Power Drift = 0.040 dB

Peak SAR (extrapolated) = 28.2 W/kg

**SAR(1 g) = 13.5 mW/g; SAR(10 g) = 6.24 mW/g**

Maximum value of SAR (measured) = 16.1 mW/g

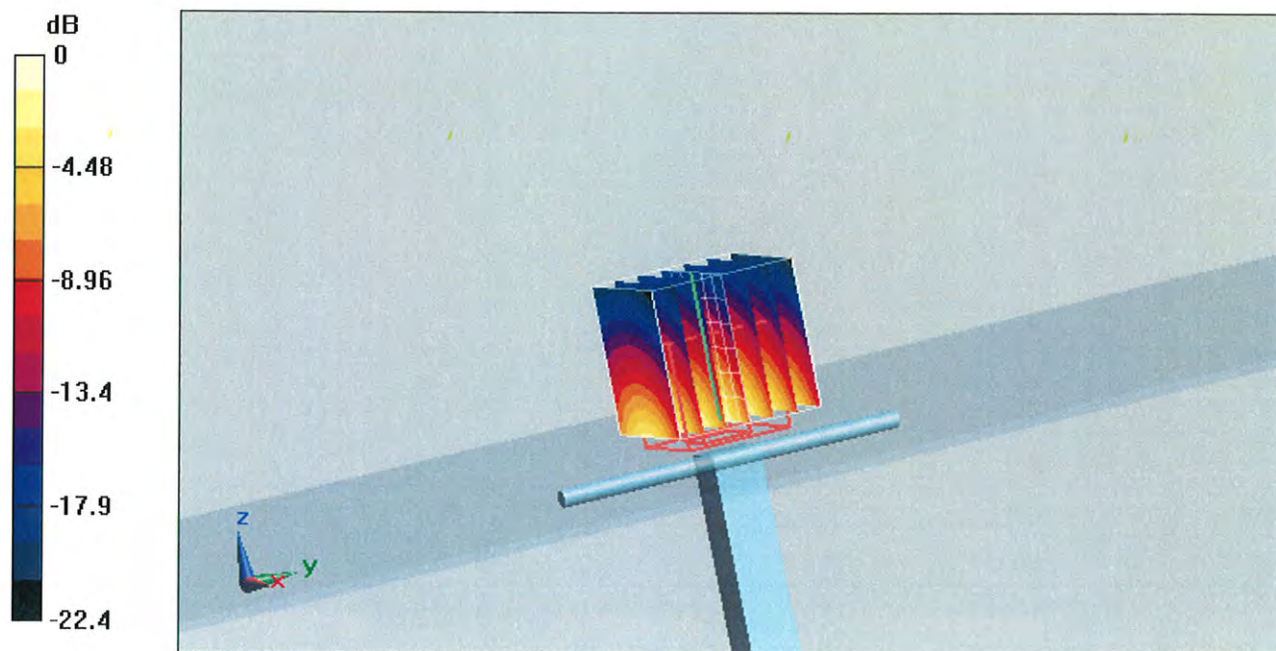

# Impedance Measurement Plot for Head TSL

17 Mar 2009 11:42:32

CH1 S11 1 U FS 1: 54.941  $\Omega$  1.4121  $\Omega$  91.732  $\mu\text{H}$  2 450.000 000 MHz

\*  
De1  
Cor

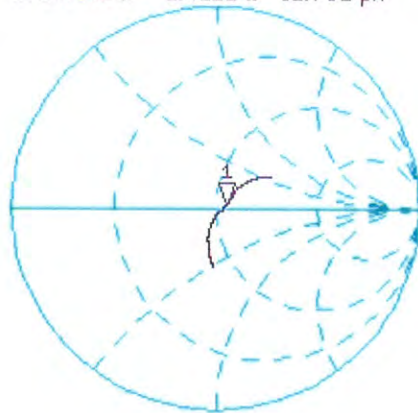

↑

CH2 S11 LOG 5 dB/REF -20 dB 1:-26.190 dB 2 450.000 000 MHz

De1  
Cor

Avg  
16

↑



START 2 250.000 000 MHz

STOP 2 650.000 000 MHz

# DASY5 Validation Report for Body TSL

Date/Time: 10.03.2009 14:20:02

Test Laboratory: SPEAG, Zurich, Switzerland

**DUT: Dipole 2450 MHz; Type: D2450V2; Serial: D2450V2 - SN:716**

Communication System: CW; Frequency: 2450 MHz; Duty Cycle: 1:1

Medium: MSL U10 BB

Medium parameters used:  $f = 2450$  MHz;  $\sigma = 2$  mho/m;  $\epsilon_r = 54.4$ ;  $\rho = 1000$  kg/m<sup>3</sup>

Phantom section: Flat Section

Measurement Standard: DASY5 (IEEE/IEC)

DASY5 Configuration:

- Probe: ES3DV2 - SN3025; ConvF(4.07, 4.07, 4.07); Calibrated: 28.04.2008
- Sensor-Surface: 3.4mm (Mechanical Surface Detection)
- Electronics: DAE4 Sn601; Calibrated: 07.03.2009
- Phantom: Flat Phantom 5.0 (back); Type: QD000P50AA; Serial: 1002
- Measurement SW: DASY5, V5.0 Build 120; SEMCAD X Version 13.4 Build 45

**Pin = 250 mW; d = 10 mm/Zoom Scan (7x7x7)/Cube 0:** Measurement grid: dx=5mm, dy=5mm, dz=5mm

Reference Value = 93.7 V/m; Power Drift = -0.00384 dB

Peak SAR (extrapolated) = 26.8 W/kg

**SAR(1 g) = 13.3 mW/g; SAR(10 g) = 6.24 mW/g**

Maximum value of SAR (measured) = 16.5 mW/g

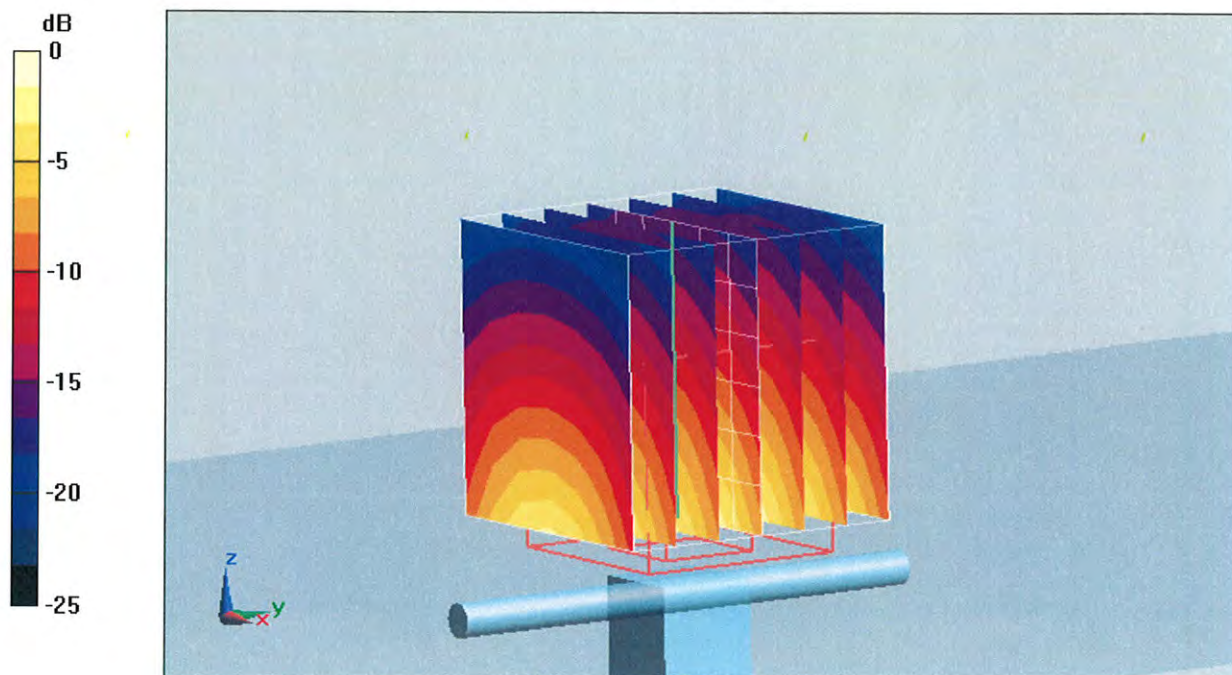

0 dB = 16.5mW/g

# Impedance Measurement Plot for Body TSL

10 Mar 2009 09:52:25

CH1 S11 1 U FS 1: 50.232  $\Omega$  4.2793  $\Omega$  277.99 pF 2 450.000 000 MHz

\*  
Del  
Cor

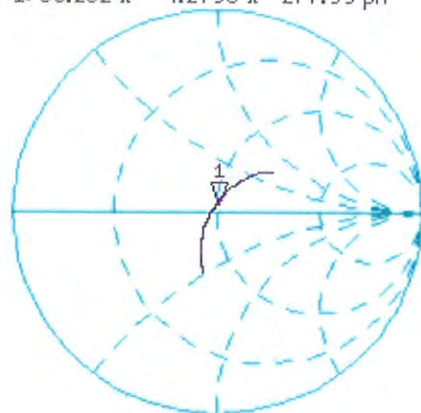

Avg  
16

↑

CH2 S11 LOG 5 dB/REF -20 dB 1: -27.386 dB 2 450.000 000 MHz

Cor

Avg  
16

↑

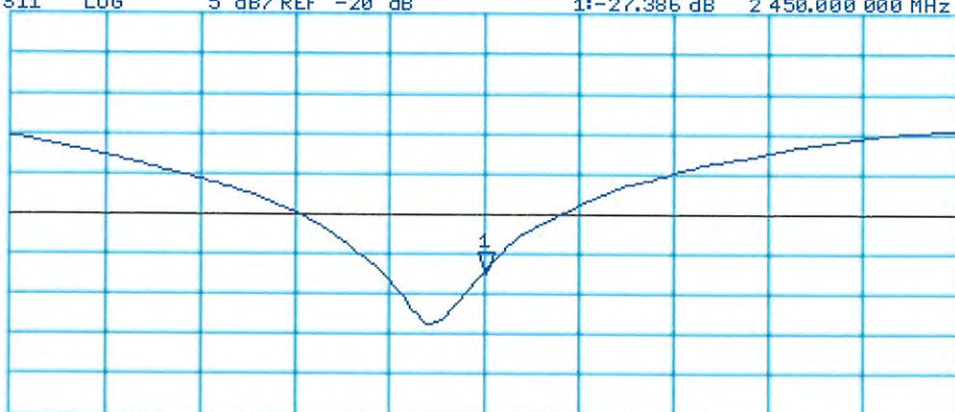

START 2 250.000 000 MHz

STOP 2 650.000 000 MHz