



Test Report

Product Name WIRELESS G ADSL2+ MODEM ROUTER
Model No. DSL-2740R, DSL-2741R
IC ID 4216A-SL2740R

Applicant D-Link Corporation

Address No.289, Sinhu 3rd Rd., Neihu District, Taipei
City 114, Taiwan, R.O.C.

Date of Receipt : 2008/06/11
Issued Date : 2008/07/23
Report No. : 086255R-RFCAP05V01
Version : V1.0

The test results relate only to the samples tested.

The test report shall not be reproduced except in full without the written approval of QuieTek Corporation.

This report must not be used to claim product endorsement by NVLAP any agency of the U.S. Government

Test Report Certification

Issued Date : 2008/07/23

Report No. : 086255R-RFCAP05V01



Filed by Industry Canada

File No.: 46405-4075/ Submission No.: 39037

Product Name	WIRELESS G ADSL2+ MODEM ROUTER
Applicant	D-Link Corporation
Address	No.289, Sinhu 3rd Rd., Neihu District, Taipei City 114, Taiwan, R.O.C.
Manufacturer	Alpha Networks Inc.
Model No.	DSL-2740R, DSL-2741R
Rated Voltage	AC 120V/60Hz
Trade Name	D-Link
Applicable Standard	RSS-210 Issue 7, Annex 8 (June 2007) ANSI C63.4: 2003
Test Result	Complied 

Test results relate only to the samples tested.

The test report shall not be reproduced except in full without the written approval of Quietek Corporation.

This report must not be used to claim product endorsement by NVLAP any agency of the U.S. Government

Documented By : *Demi Chang*
 (Demi Chang / Engineering Adm. Specialist)

Reviewed By : *Sheena Huang*
 (Sheena Huang / Engineer)

Approved By : *Roy Wang*
 (Roy Wang / Manager)

TABLE OF CONTENTS

Description	Page
1. GENERAL INFORMATION	5
1.1. EUT Description	5
1.2. Operational Description	9
1.3. Test Mode	10
1.4. Tested System Details	11
1.5. Configuration of tested System	12
1.6. EUT Exercise Software	13
1.7. Test Facility	14
2. Conducted Emission.....	15
2.1. Test Equipment.....	15
2.2. Test Setup	15
2.3. Limits	15
2.4. Test Procedure	16
2.5. Uncertainty	16
2.6. Test Result.....	17
2.7. Test Photo	65
3. Peak Power Output	68
3.1. Test Equipment.....	68
3.2. Test Setup	68
3.3. Limits	68
3.4. Uncertainty	68
3.5. Test Result.....	69
4. Radiated Emission	93
4.1. Test Equipment.....	93
4.2. Test Setup	93
4.3. Limits	94
4.4. Test Procedure	94
4.5. Uncertainty	94
4.6. Test Result.....	95
4.7. Test Photo	145
5. RF Antenna Conducted Test.....	149
5.1. Test Equipment.....	149
5.2. Test Setup	149
5.3. Limits	149
5.4. Test Procedure	149
5.5. Uncertainty	149
5.6. Test Result.....	150
6. Band Edge.....	162
6.1. Test Equipment.....	162
6.2. Test Setup	163
6.3. Limits	164
6.4. Test Procedure	164
6.5. Uncertainty	164

6.6.	Test Result.....	165
7.	Occupied Bandwidth.....	197
7.1.	Test Equipment.....	197
7.2.	Test Setup	197
7.3.	Limits	197
7.4.	Uncertainty	197
7.5.	Test Result.....	198
8.	99% Occupied Bandwidth.....	216
8.1.	Test Equipment.....	216
8.2.	Test Setup	216
8.3.	Limits	216
8.4.	Uncertainty	216
8.5.	Test Result.....	217
9.	Power Density.....	235
9.1.	Test Equipment.....	235
9.2.	Test Setup	235
9.3.	Limits	235
9.4.	Uncertainty	235
9.5.	Test Result.....	236
10.	EMI Reduction Method During Compliance Testing	256
10.1.	Attachement 1.....	257
10.2.	EUT Photograph.....	257

1. GENERAL INFORMATION

1.1. EUT Description

Product Name	WIRELESS G ADSL2+ MODEM ROUTER
Product Type	WLAN(2TX,3RX)
Trade Name	D-Link
IC ID	4216A-SL2740R
Model No.	DSL-2740R, DSL-2741R
Frequency Range -IEEE 802.11b/g & IEEE 802.11n (20MHz)	2412~2462MHz
Frequency Range- IEEE 802.11n (40MHz)	2422~2452MHz
Channel Number (IEEE 802.11b/g & IEEE 802.11n (20MHz))	11
Channel Number- IEEE 802.11n (40MHz)	7
Type of Modulation (IEEE 802.11b)	Direct Sequence Spread Spectrum (DSSS)
Type of Modulation (IEEE 802.11g)	Orthogonal Frequency Division Multiplexing (OFDM)
Data Speed (IEEE 802.11b)	1Mbps, 2Mbps, 5.5Mbps, 11Mbps
Data Speed (IEEE 802.11g)	6Mbps,9Mbps,12Mbps,18Mbps,24Mbps,36Mbps,48Mbps,54Mbps
Data Speed (IEEE 802.11n)	Support a subset of the combination of GI, MCS 0~MCS 15 and bandwidth defined in 802.11n
Antenna	ANT A (Tx/Rx): 1.8dBi ; ANT B (Tx/Rx): 1.8 dBi ; ANT C (Rx): 1.8dBi
Channel Control	Manual
Antenna Type	Monopole

Component	
LAN Cable	Non-Shielded, 1.5m
RJ11 Cable	Non-Shielded, 1.8m
Power Adapter	AMIGO, AM-121200A I/P: 120VAC 60Hz 200mA O/P: 12VAC 1200mA 14.4VA Cable Out: Non-Shielded, 1.8m
Power Adapter	FAIRWAY, WRG15F-120AB I/P: 100V-120V 1.0A max, 50-60Hz O/P: 12VAC 1.25A Cable Out: Non-Shielded, 1.8m
Power Adapter	D-Link, AH1812-B I/P: 100V-240V 0.4A max, 50-60Hz O/P: 12VAC 1.25A Cable Out: Non-Shielded, 1.8m

ANT-TX / Rx & Bandwidth

ANT-TX / Rx	SINGLE-TX		TWO-TX		Rx	
	20MHz	40MHz	20MHz	40MHz	20MHz	40MHz
IEEE802.11b	✓				✓	
IEEE802.11g	✓					
Draft 11n			✓	✓	✓	✓

ANT A / B (Tx)



ANT C (Rx)

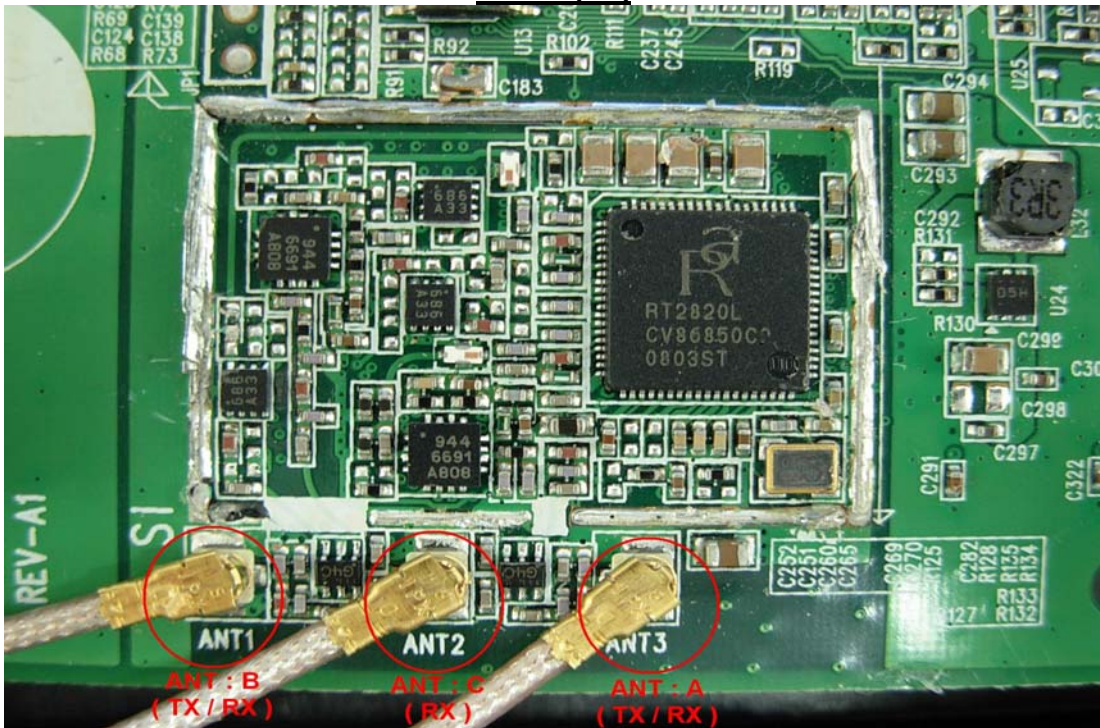

Draft 11n Spec.

MCS Index	Nss	Modulation	R	NBPS	NCBPS		NDBPS		Datarate(Mbps)			
					20MHz	40MHz	20MHz	40MHz	800nsGI		400nsGI	
									20MHz	40MHz	20MHz	40MHz
0	1	BPSK	1/2	1	52	108	26	54	6.5	13.5	7.200	15
1	1	QPSK	1/2	2	104	216	52	108	13.0	27.0	14.400	30
2	1	QPSK	3/4	2	104	216	78	162	19.5	40.5	21.700	45
3	1	16-QAM	1/2	4	208	432	104	216	26.0	54.0	28.900	60
4	1	16-QAM	3/4	4	208	432	156	324	39.0	81.0	43.300	90
5	1	64-QAM	2/3	6	312	648	208	432	52.0	108.0	57.800	120
6	1	64-QAM	3/4	6	312	648	234	486	58.5	121.5	65.000	135
7	1	64-QAM	5/6	6	312	648	260	540	65.0	135.0	72.200	150
8	2	BPSK	1/2	1	104	216	52	108	13.0	27.0	14.444	30
9	2	QPSK	1/2	2	208	432	104	216	26.0	54.0	28.889	60
10	2	QPSK	3/4	2	208	432	156	324	39.0	81.0	43.333	90
11	2	16-QAM	1/2	4	416	864	208	432	52.0	108.0	57.778	120
12	2	16-QAM	3/4	4	416	864	312	648	78.0	162.0	86.667	180
13	2	64-QAM	2/3	6	624	1296	416	864	104.0	216.0	115.556	240
14	2	64-QAM	3/4	6	624	1296	468	972	117.0	243.0	130.000	270
15	2	64-QAM	5/6	6	624	1296	520	1080	130.0	270.0	144.444	300

Symbol	Explanation
NSS	Number of spatial streams
R	Code rate
NBPS	Number of coded bits per single carrier
NCBPS	Number of coded bits per symbol
NDBPS	Number of data bits per symbol
GI	guard interval

IEEE 802.11b/g & IEEE 802.11n (20MHz)

Working Frequency of Each Channel							
Channel	Frequency	Channel	Frequency	Channel	Frequency	Channel	Frequency
001	2412 MHz	002	2417 MHz	003	2422 MHz	004	2427 MHz
005	2432 MHz	006	2437 MHz	007	2442 MHz	008	2447 MHz
009	2452 MHz	010	2457 MHz	011	2462 MHz		

IEEE 802.11n (40MHz)

Working Frequency of Each Channel							
Channel	Frequency	Channel	Frequency	Channel	Frequency	Channel	Frequency
003	2422 MHz	004	2427 MHz	005	2432 MHz	006	2437 MHz
007	2442 MHz	008	2447 MHz	009	2452 MHz		

Note:

1. The EUT is a WIRELESS G ADSL2+ MODEM ROUTER including a 2.4GHz transceiver.
2. The different of the each model is shown as below:

M/N	Annex	Description
DSL-2740R	Annex A	ADSL over Phone
DSL-2741R	Annex B	ADSL over ISDN

3. Regarding to the operation frequency, the lowest, middle and highest frequency are selected to perform the test.
4. The lowest and highest data rates are tested. Only worst case is shown in the report.
5. These tests are conducted on a sample of the equipment for the purpose of demonstrating compliance with RSS-210 for spread spectrum devices.

1.2. Operational Description

The EUT is a IEEE 802.11b / g / n for 2.4GHz wireless transceiver signal. Operating Frequency Range of the WLAN is from 2412 MHz to 2462 MHz. The DSL-2740R, DSL-2741R Wireless Router is supplied with an Ethernet cable in the package. The wireless router has an integrated auto-crossover function. The DSL-2740R, DSL-2741R Wireless Router has two transmitters and three receivers. The 802.11b/g is single transmit. The 802.11n has two transmit and includes both 20Mbps and 40Mbps.

The device provided four kinds of transmitting speed 1, 2, 5.5 and 11Mbps for IEEE 802.11b and eight kinds of transmitting speed 6, 9, 12, 18, 24, 36, 48 and 54Mbps for IEEE 802.11g and MCS0 – MCS15 for IEEE 802.11n. The device of RF carrier is DQPSK, DBPSK and CCK. Operation in 2.4GHz Direct Sequence Spread Spectrum (DSSS) radio transmission for IEEE 802.11b and Orthogonal Frequency Division Multiplexing (OFDM) for IEEE 802.11g.

1.3. Test Mode

Quietek has verified the construction and function in typical operation. The preliminary tests were performed in different data rate, and to find the worst condition, which was shown in this test report. The following table is the final test mode.

TX	Mode 1: Transmit (AMIGO) Mode 2: Transmit (FAIRWAY) Mode 3: Transmit (D-Link)
----	-------------------------------------------------------------------------------------

Test Items	Mode1	Channel	Antenna	Result
Conducted Emission	b/g/11n(20M)/11n(40MHz)	6	A/A+B	Complies
Peak Power Output	b/g	1 /6/ 11	A	Complies
	11n-MCS15(20MHz)	1 /6/ 11	A+B	Complies
	11n-MCS15 (40MHz)	3 /6/ 9	A+B	Complies
Radiated Emission	b/g	1 /6/ 11	A	Complies
	11n-MCS15(20MHz)	1 /6/ 11	A+B	Complies
	11n-MCS15 (40MHz)	3 /6/ 9	A+B	Complies
RF antenna conducted test	b/g	1 /6/ 11	A	Complies
	11n-MCS15 (20MHz)	1 /6/ 11	A/B	Complies
	11n-MCS15 (40MHz)	3 /6/ 9	A/B	Complies
Radiated Emission Band Edge	b/g	1 /6/ 11	A	Complies
	11n-MCS15 (20MHz)	1 /6/ 11	A+B	Complies
	11n-MCS15 (40MHz)	3 /6/ 9	A+B	Complies
Occupied Bandwidth	b/g	1 /6/ 11	A	Complies
	11n-MCS15 (20MHz)	1 /6/ 11	A/B	Complies
	11n-MCS15 (40MHz)	3 /6/ 9	A/B	Complies
99% Occupied Bandwidth	b/g	1 /6/ 11	A	Complies
	11n-MCS15 (20MHz)	1 /6/ 11	A/B	Complies
	11n-MCS15 (40MHz)	3 /6/ 9	A/B	Complies
Power Density	b/g	1 /6/ 11	A	Complies
	11n-MCS15 (20MHz)	1 /6/ 11	A+B	Complies
	11n-MCS15 (40MHz)	3 /6/ 9	A+B	Complies

1.4. Tested System Details

The types for all equipment, plus descriptions of all cables used in the tested system (including inserted cards) are:

Product	Manufacturer	Model No.	Serial No.	FCC ID	Power Cord	
1	CheetahAccess Secure	Accton	AC-IG1104	N/A	DoC	Non-shielded, 1.8m
2	Notebook PC	DELL	LATITUDE D400	GK43D1S	DoC	Non-shielded, 1.7m, a ferrite core bonded
3	CO	D-Link	DAS-3224	N/A	DoC	--
4	PC	ASUS	P2L97	AS10226	DoC	Non-shielded, 1.8m

1.5. Configuration of tested System

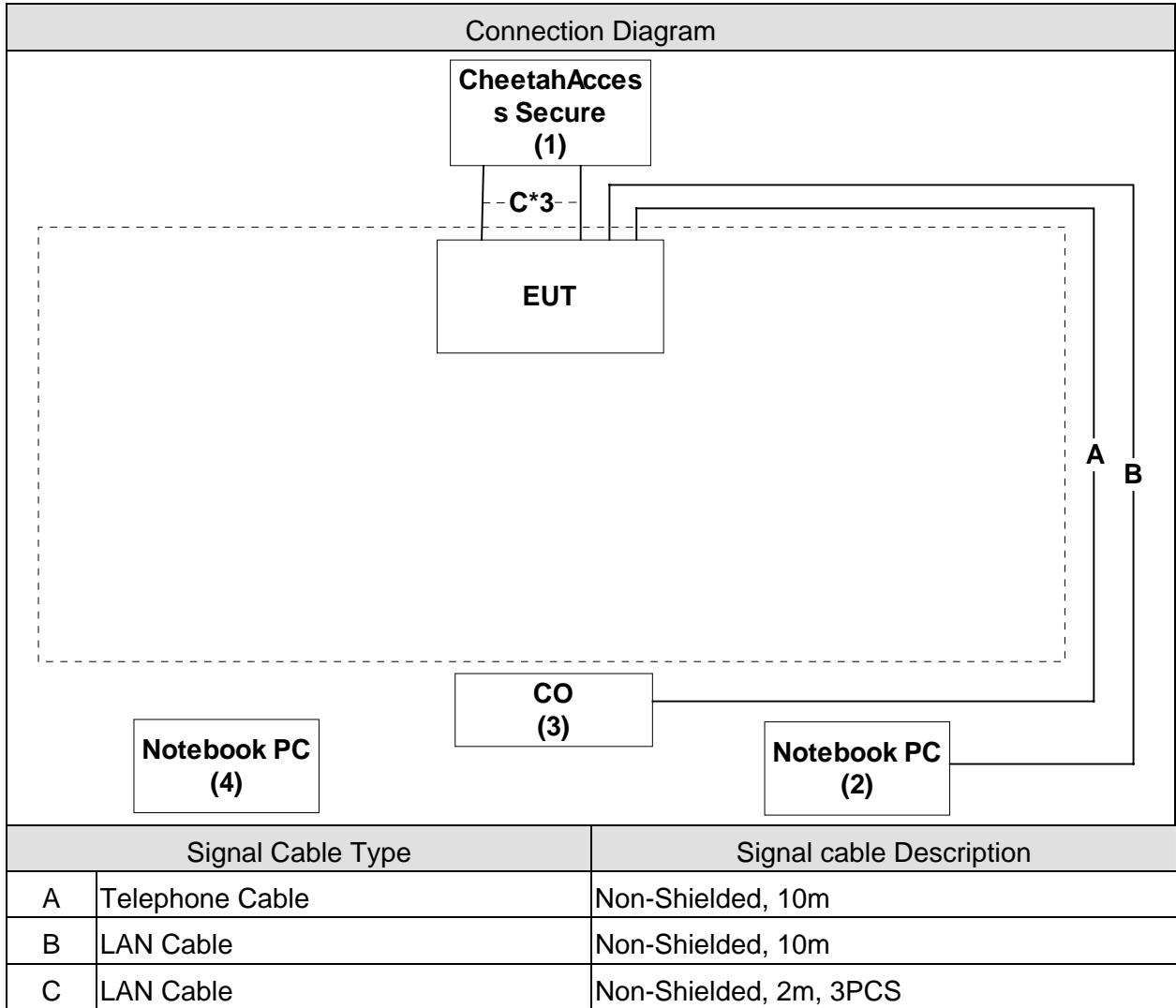

1.6. EUT Exercise Software

1	Setup the EUT and simulators as shown on 1.5.
2	Turn on the power of all equipment.
3	Boot the Notebook PC from Hard Disk.
4	Data will communicate by connecting to LAN port of Notebook PC.
5	The Notebook PC 's monitor will show the transmitting and receiving characteristics when the communication is success.
6	Repeat the above procedure (4) to (5).

1.7. Test Facility

Ambient conditions in the laboratory:

Items	Required (IEC 68-1)	Actual
Temperature (°C)	15-35	20-35
Humidity (%RH)	25-75	50-65
Barometric pressure (mbar)	860-1060	950-1000

Site Description: January 27, 2005 File on
 Certification and Engineering Bureau
 3701 Carling Ave., Building 94
 P.O. Box 11490, Station "H"
 Ottawa, Ontario
 K2H 8S2
 Registration No. for Test Site IC 5654-2
 File No.: 46405-5654
 Submission: 104921

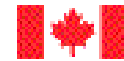

**Industry
Canada**

Site Name: Quietek Corporation

Site Address: No.75-1, Wang-Yeh Valley, Yung-Hsing,
 Chiung-Lin, Hsin-Chu County,
 Taiwan, R.O.C.
 TEL : 886-3-592-8858 / FAX : 886-3-592-8859
 E-Mail: service@quietek.com

2. Conducted Emission

2.1. Test Equipment

The following test equipment are used during the conducted emission test:

Conducted Emission / SR3

Instrument	Manufacturer	Type No.	Serial No	Cal. Date
4-Wire ISN	R & S	ENY 41	837032/001	2008/04/15
Double 2-Wire ISN	R & S	ENY 22	835354/008	2008/04/15
LISN	R&S	ESH3-Z5	836679/022	2008/06/17
LISN	R & S	ESH3-Z5	836679/013	2007/12/30
Pulse Limiter	R & S	ESH3-Z2	100411	2007/11/16
Test Receiver	R & S	ESCS 30	100149	2007/11/15

Note: All instruments are calibrated every one year.

2.2. Test Setup

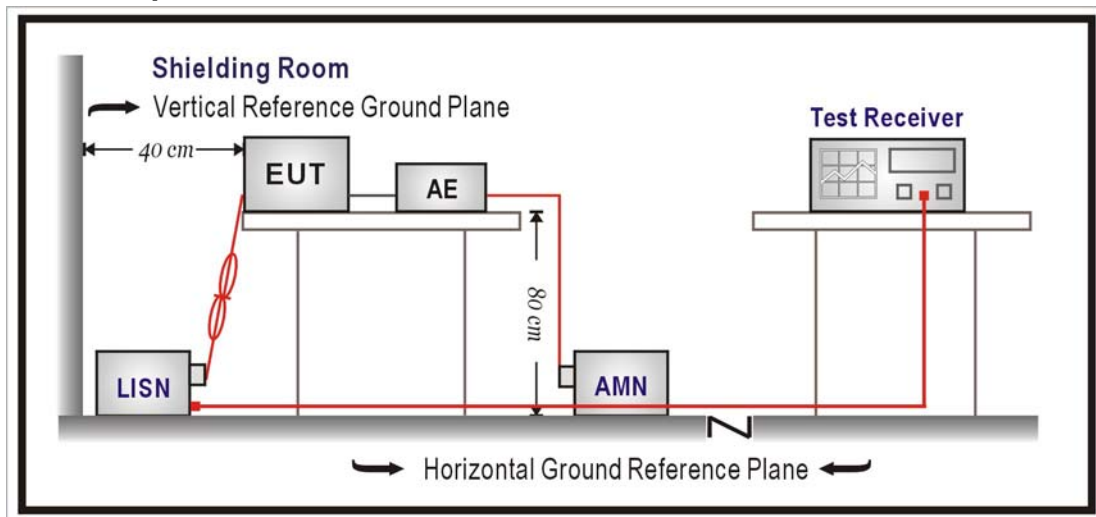

2.3. Limits

RSS-210 Section 7.4 Limits (FCC 15.207)		
Frequency MHz	Limits	
	dBuV	dBuV
0.15 - 0.50	66-56	56-46
0.50-5.0	56	46
5.0 - 30	60	50

2.4. Test Procedure

The EUT and simulators are connected to the main power through a line impedance stabilization network (L.I.S.N.). This provides a 50 ohm /50uH coupling impedance for the measuring equipment. The peripheral devices are also connected to the main power through a LISN that provides a 50ohm /50uH coupling impedance with 50ohm termination. (Please refers to the block diagram of the test setup and photographs.)

Both sides of A.C. line are checked for maximum conducted interference. In order to find the maximum emission, the relative positions of equipment and all of the interface cables must be changed according to ANSI C63.4: 2003 on conducted measurement.

Conducted emissions were invested over the frequency range from 0.15MHz to 30MHz using a receiver bandwidth of 9kHz.

2.5. Uncertainty

The measurement uncertainty is defined as ± 2.26 dB.

2.6. Test Result

Site : ShieldingRoom3	Time : 2008/06/26 - 14:42
Limit : CISPR_B_00M_QP	Margin : 0
Probe : SR3_LISN(16A) - Line1	Power : AC 120V/60Hz
EUT : WIRELESS G ADSL2+ MODEM ROUTER	Note : Mode 1: Transmit (AMIGO)-B

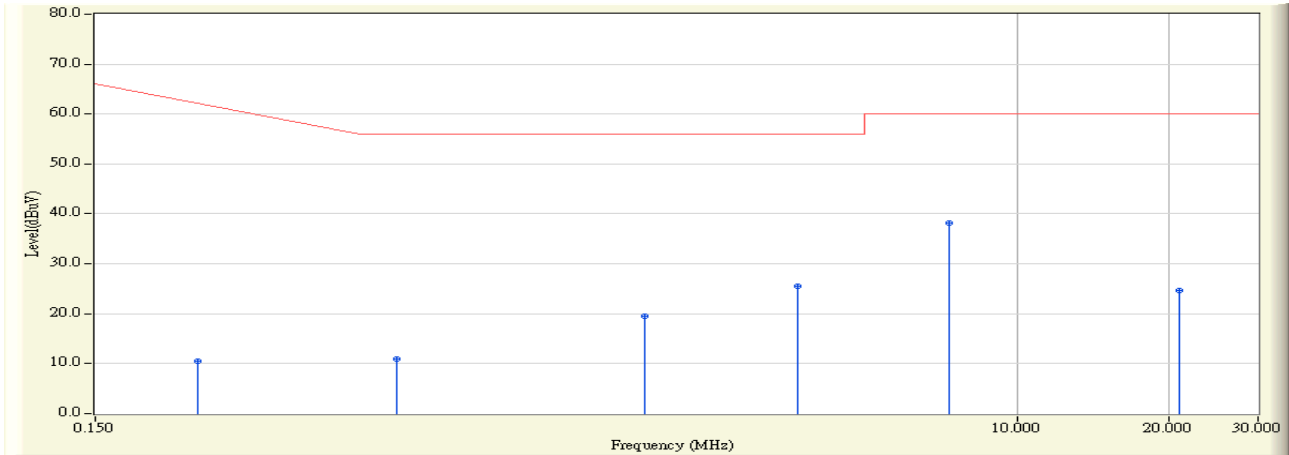

	Frequency (MHz)	Correct Factor (dB)	Reading Level (dBuV)	Measure Level (dBuV)	Margin (dB)	Limit (dBuV)	Detector Type
1	0.240	-0.020	10.560	10.540	-52.889	63.429	QUASPEAK
2	0.591	0.034	10.960	10.994	-45.006	56.000	QUASPEAK
3	1.830	0.110	19.320	19.430	-36.570	56.000	QUASPEAK
4	3.670	0.190	25.280	25.470	-30.530	56.000	QUASPEAK
5	* 7.341	0.370	37.880	38.250	-21.750	60.000	QUASPEAK
6	20.920	0.910	23.840	24.750	-35.250	60.000	QUASPEAK

Note:

1. All Reading Levels are Quasi-Peak and average value.
2. " * ", means this data is the worst emission level.
3. Measurement Level = Reading Level + Correct Factor.

Site : ShieldingRoom3	Time : 2008/06/26 - 14:42
Limit : CISPR_B_00M_AV	Margin : 0
Probe : SR3_LISN(16A) - Line1	Power : AC 120V/60Hz
EUT : WIRELESS G ADSL2+ MODEM ROUTER	Note : Mode 1: Transmit (AMIGO)-B

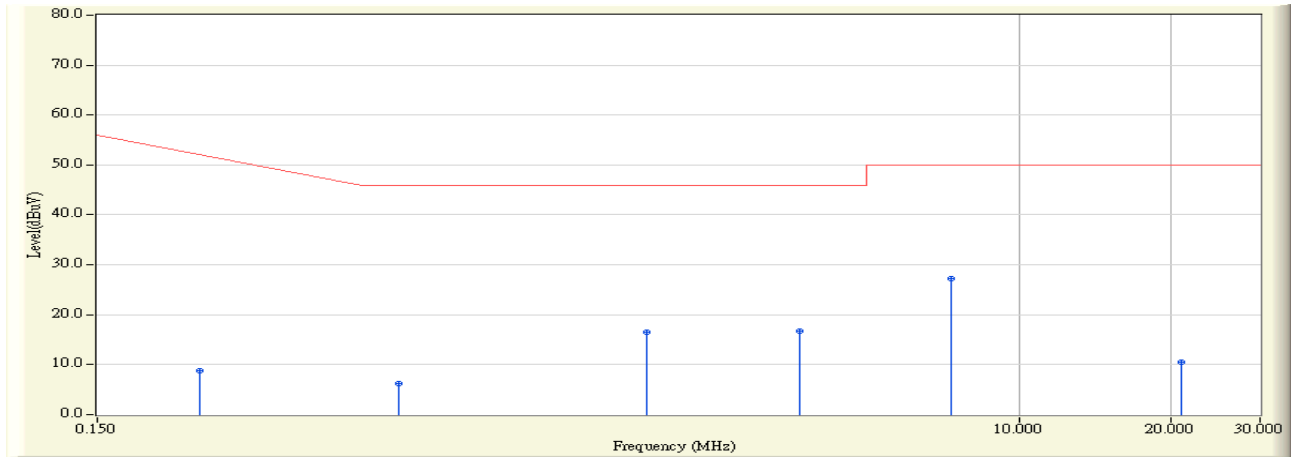

	Frequency (MHz)	Correct Factor (dB)	Reading Level (dBuV)	Measure Level (dBuV)	Margin (dB)	Limit (dBuV)	Detector Type
1	0.240	-0.020	8.910	8.890	-44.539	53.429	AVERAGE
2	0.591	0.034	6.140	6.174	-39.826	46.000	AVERAGE
3	1.830	0.110	16.390	16.500	-29.500	46.000	AVERAGE
4	3.670	0.190	16.460	16.650	-29.350	46.000	AVERAGE
5	* 7.341	0.370	26.890	27.260	-22.740	50.000	AVERAGE
6	20.920	0.910	9.660	10.570	-39.430	50.000	AVERAGE

Note:

1. All Reading Levels are Quasi-Peak and average value.
2. " * ", means this data is the worst emission level.
3. Measurement Level = Reading Level + Correct Factor.

Site : ShieldingRoom3	Time : 2008/06/26 - 15:01
Limit : CISPR_B_00M_QP	Margin : 0
Probe : SR3_LISN(16A) - Line2	Power : AC 120V/60Hz
EUT : WIRELESS G ADSL2+ MODEM ROUTER	Note : Mode 1: Transmit (AMIGO)-B

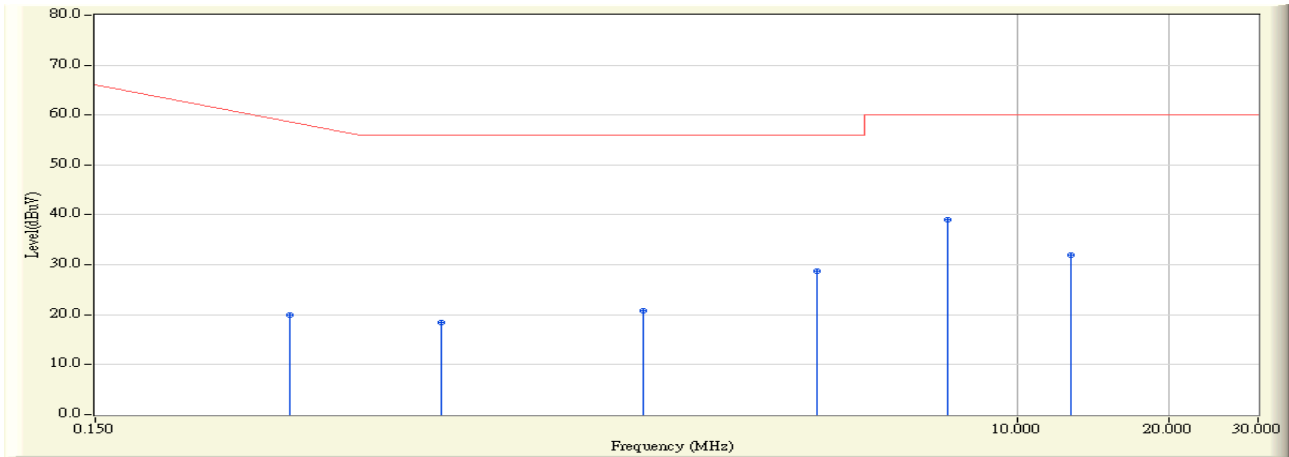

	Frequency (MHz)	Correct Factor (dB)	Reading Level (dBuV)	Measure Level (dBuV)	Margin (dB)	Limit (dBuV)	Detector Type
1	0.365	0.019	19.830	19.849	-40.008	59.857	QUASPEAK
2	0.728	0.059	18.490	18.550	-37.450	56.000	QUASPEAK
3	1.826	0.150	20.760	20.910	-35.090	56.000	QUASPEAK
4	4.013	0.250	28.560	28.810	-27.190	56.000	QUASPEAK
5	* 7.306	0.410	38.550	38.960	-21.040	60.000	QUASPEAK
6	12.806	0.680	31.180	31.860	-28.140	60.000	QUASPEAK

Note:

1. All Reading Levels are Quasi-Peak and average value.
2. " * ", means this data is the worst emission level.
3. Measurement Level = Reading Level + Correct Factor.

Site : ShieldingRoom3	Time : 2008/06/26 - 15:01
Limit : CISPR_B_00M_AV	Margin : 0
Probe : SR3_LISN(16A) - Line2	Power : AC 120V/60Hz
EUT : WIRELESS G ADSL2+ MODEM ROUTER	Note : Mode 1: Transmit (AMIGO)-B

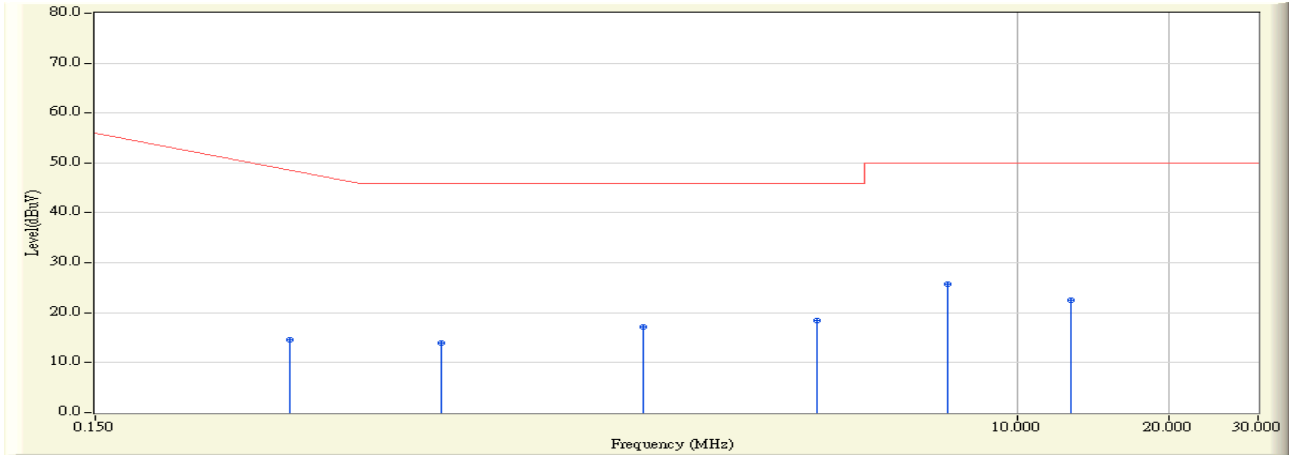

	Frequency (MHz)	Correct Factor (dB)	Reading Level (dBuV)	Measure Level (dBuV)	Margin (dB)	Limit (dBuV)	Detector Type
1	0.365	0.019	14.660	14.679	-35.178	49.857	AVERAGE
2	0.728	0.059	13.940	14.000	-32.000	46.000	AVERAGE
3	1.826	0.150	17.080	17.230	-28.770	46.000	AVERAGE
4	4.013	0.250	18.120	18.370	-27.630	46.000	AVERAGE
5	* 7.306	0.410	25.380	25.790	-24.210	50.000	AVERAGE
6	12.806	0.680	21.780	22.460	-27.540	50.000	AVERAGE

Note:

1. All Reading Levels are Quasi-Peak and average value.
2. " * ", means this data is the worst emission level.
3. Measurement Level = Reading Level + Correct Factor.

Site : ShieldingRoom3	Time : 2008/06/26 - 15:06
Limit : CISPR_B_00M_QP	Margin : 0
Probe : SR3_LISN(16A) - Line1	Power : AC 120V/60Hz
EUT : WIRELESS G ADSL2+ MODEM ROUTER	Note : Mode 1: Transmit (AMIGO)-G

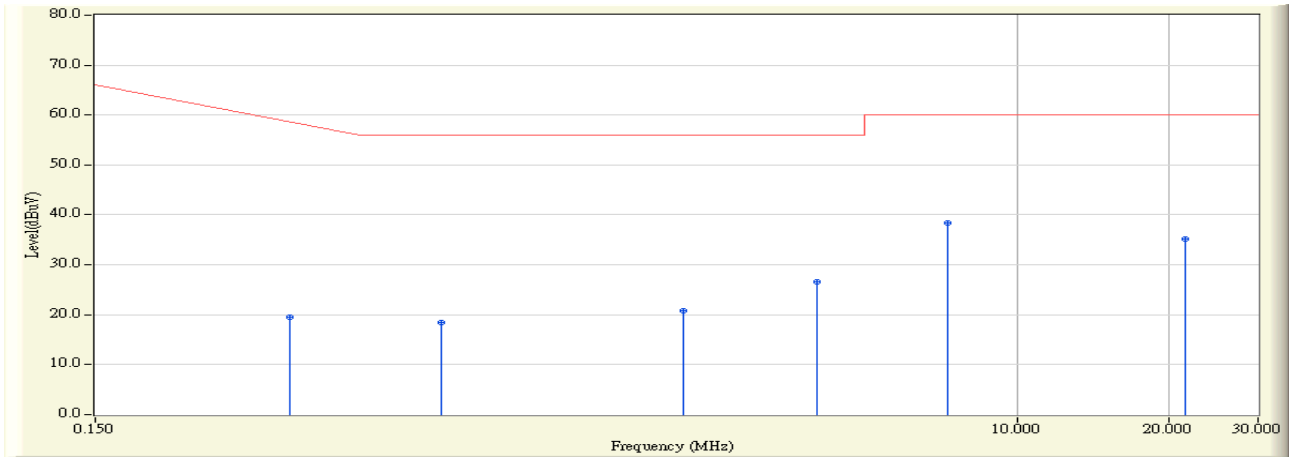

	Frequency (MHz)	Correct Factor (dB)	Reading Level (dBuV)	Measure Level (dBuV)	Margin (dB)	Limit (dBuV)	Detector Type
1	0.365	0.009	19.480	19.489	-40.368	59.857	QUASPEAK
2	0.728	0.040	18.510	18.550	-37.450	56.000	QUASPEAK
3	2.189	0.120	20.790	20.910	-35.090	56.000	QUASPEAK
4	4.013	0.210	26.460	26.670	-29.330	56.000	QUASPEAK
5	* 7.295	0.370	38.100	38.470	-21.530	60.000	QUASPEAK
6	21.514	0.920	34.310	35.230	-24.770	60.000	QUASPEAK

Note:

1. All Reading Levels are Quasi-Peak and average value.
2. " * ", means this data is the worst emission level.
3. Measurement Level = Reading Level + Correct Factor.

Site : ShieldingRoom3	Time : 2008/06/26 - 15:06
Limit : CISPR_B_00M_AV	Margin : 0
Probe : SR3_LISN(16A) - Line1	Power : AC 120V/60Hz
EUT : WIRELESS G ADSL2+ MODEM ROUTER	Note : Mode 1: Transmit (AMIGO)-G

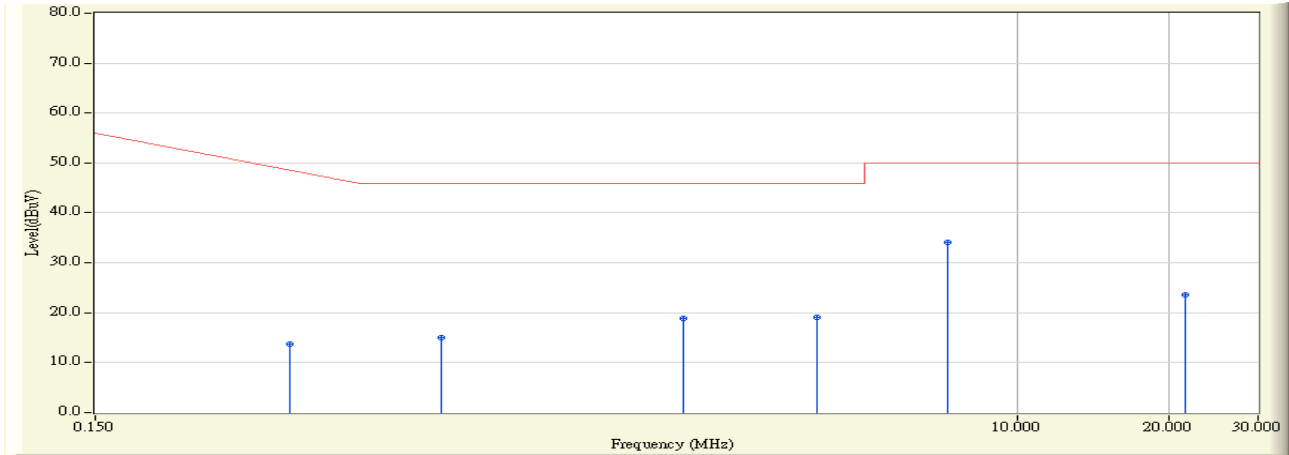

	Frequency (MHz)	Correct Factor (dB)	Reading Level (dBuV)	Measure Level (dBuV)	Margin (dB)	Limit (dBuV)	Detector Type
1	0.365	0.009	13.680	13.689	-36.168	49.857	AVERAGE
2	0.728	0.040	14.880	14.920	-31.080	46.000	AVERAGE
3	2.189	0.120	18.830	18.950	-27.050	46.000	AVERAGE
4	4.013	0.210	18.960	19.170	-26.830	46.000	AVERAGE
5	* 7.295	0.370	33.830	34.200	-15.800	50.000	AVERAGE
6	21.514	0.920	22.770	23.690	-26.310	50.000	AVERAGE

Note:

1. All Reading Levels are Quasi-Peak and average value.
2. " * ", means this data is the worst emission level.
3. Measurement Level = Reading Level + Correct Factor.

Site : ShieldingRoom3	Time : 2008/06/26 - 15:11
Limit : CISPR_B_00M_QP	Margin : 0
Probe : SR3_LISN(16A) - Line2	Power : AC 120V/60Hz
EUT : WIRELESS G ADSL2+ MODEM ROUTER	Note : Mode 1: Transmit (AMIGO)-G

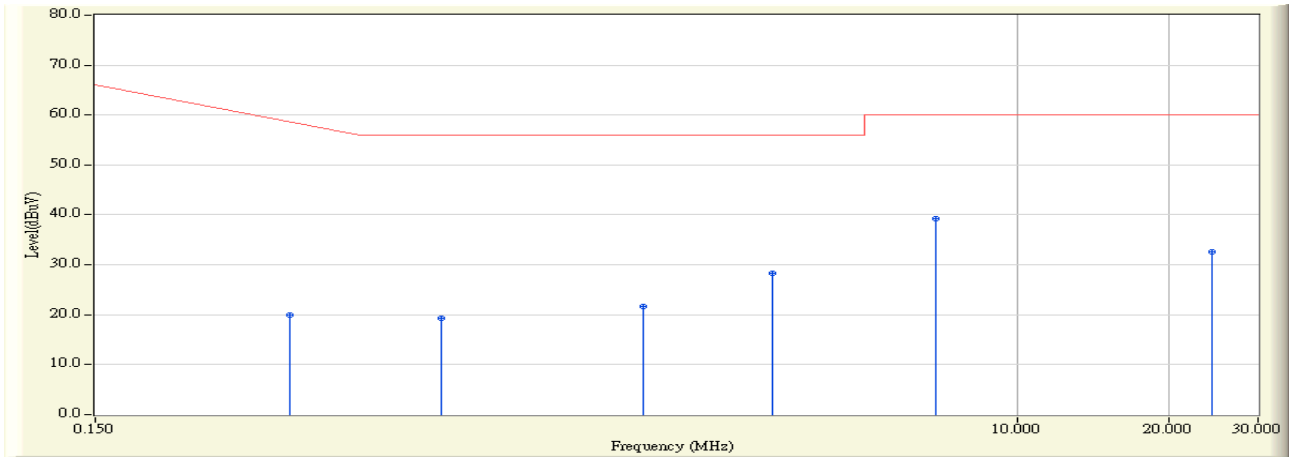

	Frequency (MHz)	Correct Factor (dB)	Reading Level (dBuV)	Measure Level (dBuV)	Margin (dB)	Limit (dBuV)	Detector Type
1	0.364	0.018	19.970	19.988	-39.898	59.886	QUASPEAK
2	0.728	0.059	19.170	19.230	-36.770	56.000	QUASPEAK
3	1.824	0.150	21.570	21.720	-34.280	56.000	QUASPEAK
4	3.279	0.220	28.100	28.320	-27.680	56.000	QUASPEAK
5	* 6.927	0.390	38.930	39.320	-20.680	60.000	QUASPEAK
6	24.349	1.090	31.460	32.550	-27.450	60.000	QUASPEAK

Note:

1. All Reading Levels are Quasi-Peak and average value.
2. " * ", means this data is the worst emission level.
3. Measurement Level = Reading Level + Correct Factor.

Site : ShieldingRoom3	Time : 2008/06/26 - 15:11
Limit : CISPR_B_00M_AV	Margin : 0
Probe : SR3_LISN(16A) - Line2	Power : AC 120V/60Hz
EUT : WIRELESS G ADSL2+ MODEM ROUTER	Note : Mode 1: Transmit (AMIGO)-G

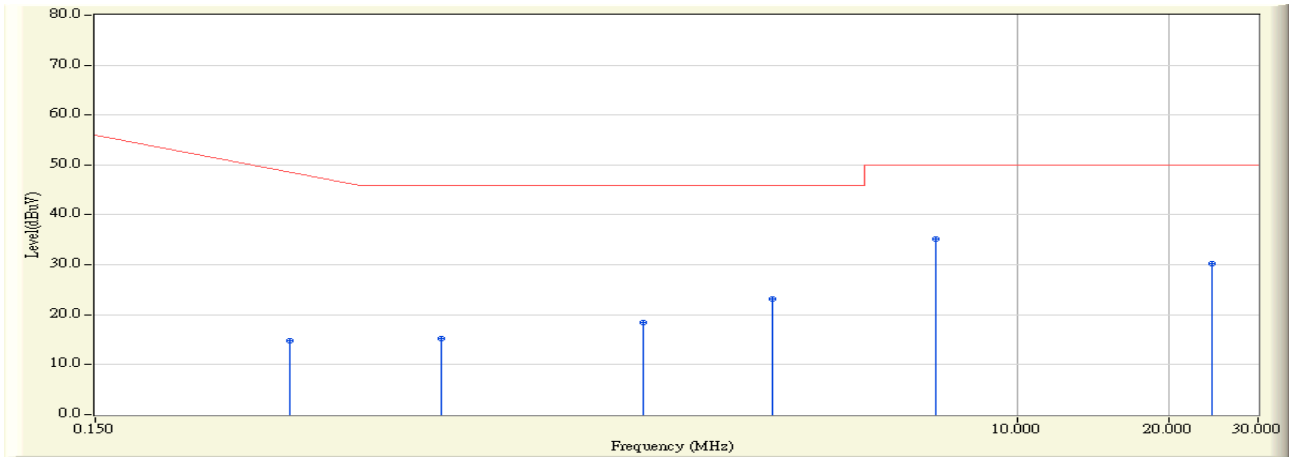

	Frequency (MHz)	Correct Factor (dB)	Reading Level (dBuV)	Measure Level (dBuV)	Margin (dB)	Limit (dBuV)	Detector Type
1	0.364	0.018	14.870	14.888	-34.998	49.886	AVERAGE
2	0.728	0.059	15.130	15.190	-30.810	46.000	AVERAGE
3	1.824	0.150	18.240	18.390	-27.610	46.000	AVERAGE
4	3.279	0.220	22.960	23.180	-22.820	46.000	AVERAGE
5	* 6.927	0.390	34.820	35.210	-14.790	50.000	AVERAGE
6	24.349	1.090	29.190	30.280	-19.720	50.000	AVERAGE

Note:

1. All Reading Levels are Quasi-Peak and average value.
2. " * ", means this data is the worst emission level.
3. Measurement Level = Reading Level + Correct Factor.

Site : ShieldingRoom3	Time : 2008/06/26 - 15:19
Limit : CISPR_B_00M_QP	Margin : 0
Probe : SR3_LISN(16A) - Line1	Power : AC 120V/60Hz
EUT : WIRELESS G ADSL2+ MODEM ROUTER	Note : Mode 1: Transmit (AMIGO)-N-20M

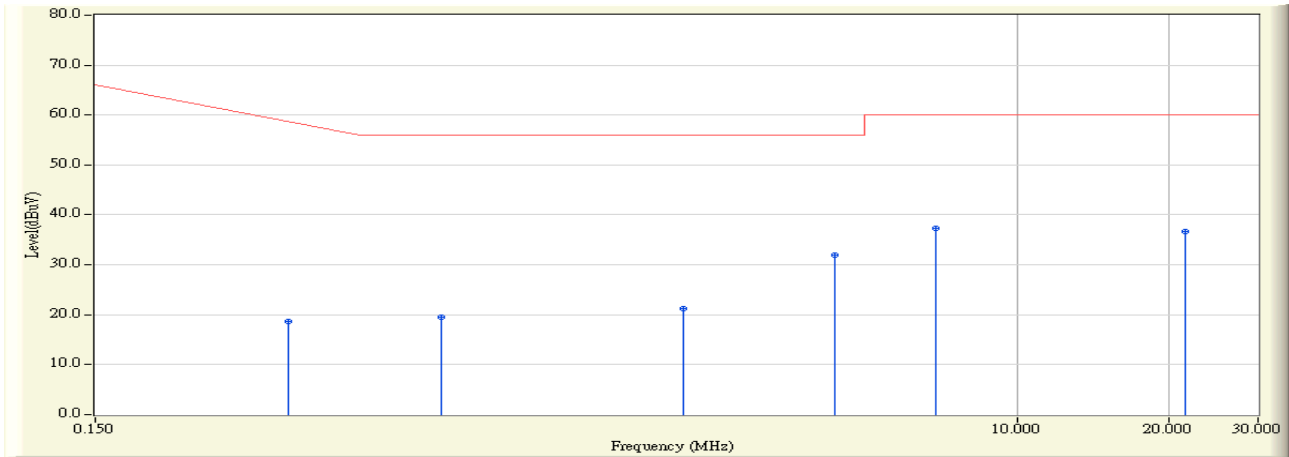

	Frequency (MHz)	Correct Factor (dB)	Reading Level (dBuV)	Measure Level (dBuV)	Margin (dB)	Limit (dBuV)	Detector Type
1	0.361	0.007	18.730	18.737	-41.234	59.971	QUASPEAK
2	0.727	0.040	19.390	19.430	-36.570	56.000	QUASPEAK
3	2.185	0.120	21.090	21.210	-34.790	56.000	QUASPEAK
4	4.373	0.230	31.790	32.020	-23.980	56.000	QUASPEAK
5	* 6.917	0.350	36.890	37.240	-22.760	60.000	QUASPEAK
6	21.493	0.920	35.770	36.690	-23.310	60.000	QUASPEAK

Note:

1. All Reading Levels are Quasi-Peak and average value.
2. " * ", means this data is the worst emission level.
3. Measurement Level = Reading Level + Correct Factor.

Site : ShieldingRoom3	Time : 2008/06/26 - 15:19
Limit : CISPR_B_00M_AV	Margin : 0
Probe : SR3_LISN(16A) - Line1	Power : AC 120V/60Hz
EUT : WIRELESS G ADSL2+ MODEM ROUTER	Note : Mode 1: Transmit (AMIGO)-N-20M

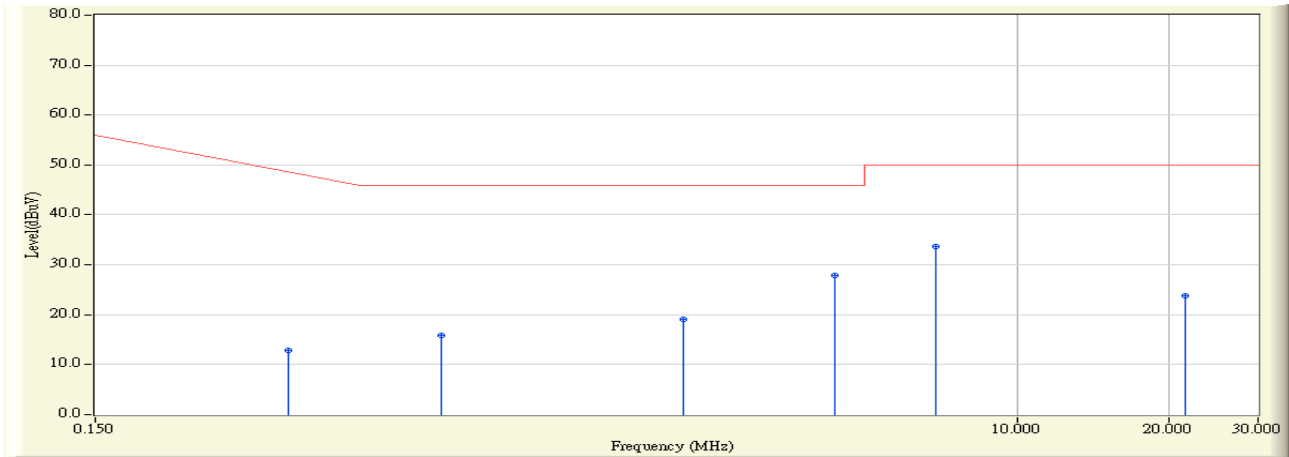

	Frequency (MHz)	Correct Factor (dB)	Reading Level (dBuV)	Measure Level (dBuV)	Margin (dB)	Limit (dBuV)	Detector Type
1	0.361	0.007	12.940	12.947	-37.024	49.971	AVERAGE
2	0.727	0.040	15.850	15.890	-30.110	46.000	AVERAGE
3	2.185	0.120	19.030	19.150	-26.850	46.000	AVERAGE
4	4.373	0.230	27.690	27.920	-18.080	46.000	AVERAGE
5	* 6.917	0.350	33.320	33.670	-16.330	50.000	AVERAGE
6	21.493	0.920	22.850	23.770	-26.230	50.000	AVERAGE

Note:

1. All Reading Levels are Quasi-Peak and average value.
2. " * ", means this data is the worst emission level.
3. Measurement Level = Reading Level + Correct Factor.

Site : ShieldingRoom3	Time : 2008/06/26 - 15:24
Limit : CISPR_B_00M_QP	Margin : 0
Probe : SR3_LISN(16A) - Line2	Power : AC 120V/60Hz
EUT : WIRELESS G ADSL2+ MODEM ROUTER	Note : Mode 1: Transmit (AMIGO)-N-20M

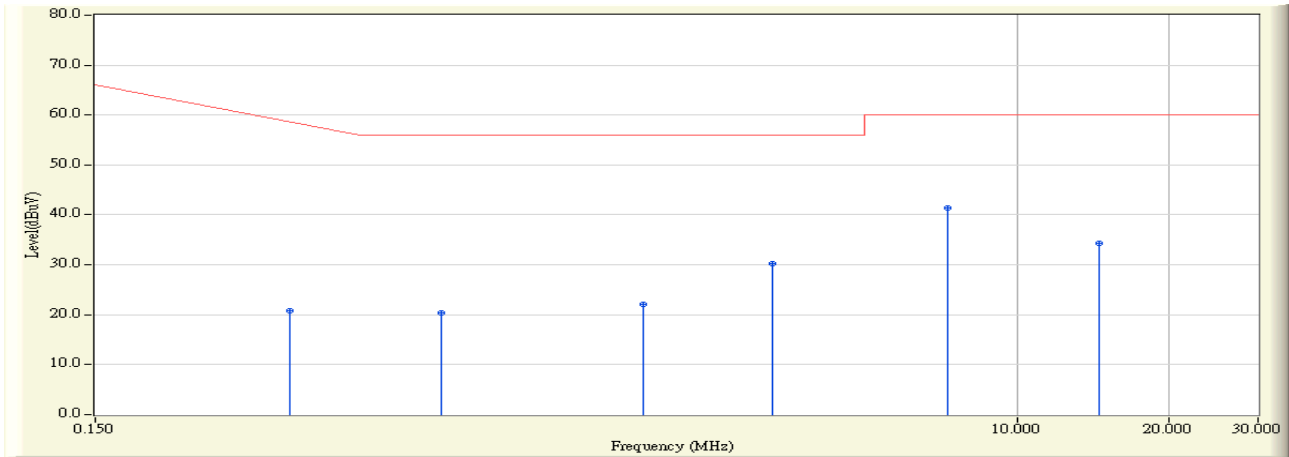

	Frequency (MHz)	Correct Factor (dB)	Reading Level (dBuV)	Measure Level (dBuV)	Margin (dB)	Limit (dBuV)	Detector Type
1	0.365	0.019	20.740	20.759	-39.098	59.857	QUASPEAK
2	0.728	0.059	20.280	20.340	-35.660	56.000	QUASPEAK
3	1.822	0.150	21.870	22.020	-33.980	56.000	QUASPEAK
4	3.275	0.220	29.920	30.140	-25.860	56.000	QUASPEAK
5	* 7.279	0.410	41.010	41.420	-18.580	60.000	QUASPEAK
6	14.560	0.780	33.580	34.360	-25.640	60.000	QUASPEAK

Note:

1. All Reading Levels are Quasi-Peak and average value.
2. " * ", means this data is the worst emission level.
3. Measurement Level = Reading Level + Correct Factor.

Site : ShieldingRoom3	Time : 2008/06/26 - 15:24
Limit : CISPR_B_00M_AV	Margin : 0
Probe : SR3_LISN(16A) - Line2	Power : AC 120V/60Hz
EUT : WIRELESS G ADSL2+ MODEM ROUTER	Note : Mode 1: Transmit (AMIGO)-N-20M

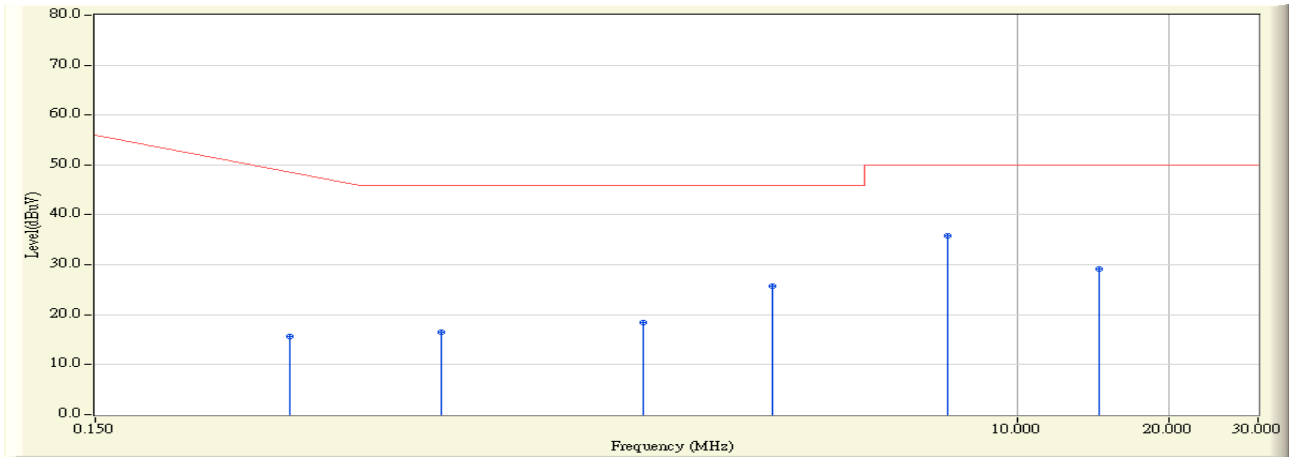

	Frequency (MHz)	Correct Factor (dB)	Reading Level (dBuV)	Measure Level (dBuV)	Margin (dB)	Limit (dBuV)	Detector Type
1	0.365	0.019	15.630	15.649	-34.208	49.857	AVERAGE
2	0.728	0.059	16.380	16.440	-29.560	46.000	AVERAGE
3	1.822	0.150	18.310	18.460	-27.540	46.000	AVERAGE
4	3.275	0.220	25.480	25.700	-20.300	46.000	AVERAGE
5	* 7.279	0.410	35.470	35.880	-14.120	50.000	AVERAGE
6	14.560	0.780	28.440	29.220	-20.780	50.000	AVERAGE

Note:

1. All Reading Levels are Quasi-Peak and average value.
2. " * ", means this data is the worst emission level.
3. Measurement Level = Reading Level + Correct Factor.

Site : ShieldingRoom3	Time : 2008/06/26 - 15:29
Limit : CISPR_B_00M_QP	Margin : 0
Probe : SR3_LISN(16A) - Line1	Power : AC 120V/60Hz
EUT : WIRELESS G ADSL2+ MODEM ROUTER	Note : Mode 1: Transmit (AMIGO)-N-40M

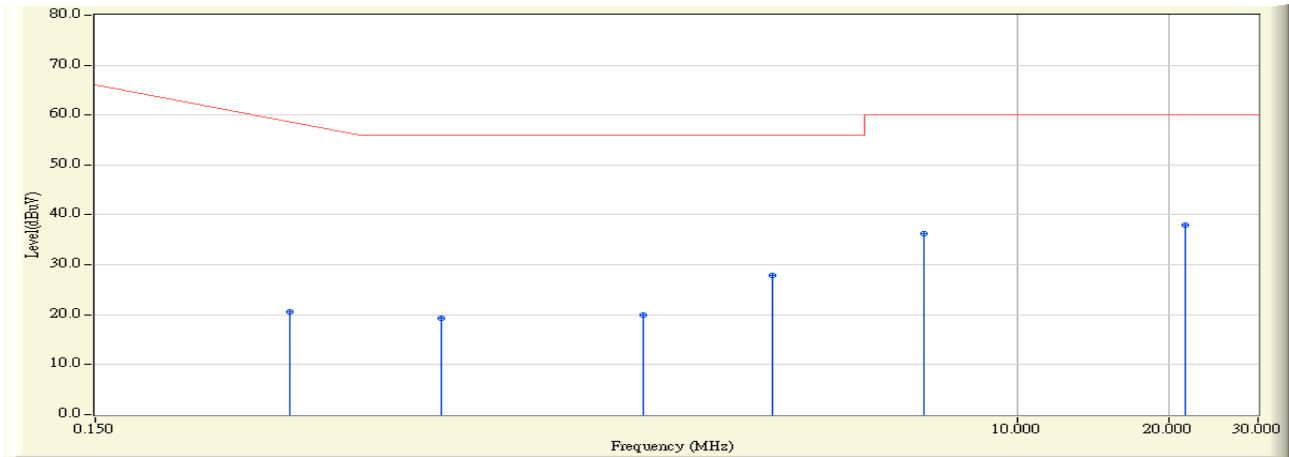

		Frequency (MHz)	Correct Factor (dB)	Reading Level (dBuV)	Measure Level (dBuV)	Margin (dB)	Limit (dBuV)	Detector Type
1		0.365	0.009	20.580	20.589	-39.268	59.857	QUASPEAK
2		0.726	0.040	19.370	19.410	-36.590	56.000	QUASPEAK
3		1.822	0.110	19.780	19.890	-36.110	56.000	QUASPEAK
4		3.275	0.180	27.780	27.960	-28.040	56.000	QUASPEAK
5		6.552	0.330	35.910	36.240	-23.760	60.000	QUASPEAK
6	*	21.466	0.920	36.950	37.870	-22.130	60.000	QUASPEAK

Note:

1. All Reading Levels are Quasi-Peak and average value.
2. " * ", means this data is the worst emission level.
3. Measurement Level = Reading Level + Correct Factor.

Site : ShieldingRoom3	Time : 2008/06/26 - 15:29
Limit : CISPR_B_00M_AV	Margin : 0
Probe : SR3_LISN(16A) - Line1	Power : AC 120V/60Hz
EUT : WIRELESS G ADSL2+ MODEM ROUTER	Note : Mode 1: Transmit (AMIGO)-N-40M

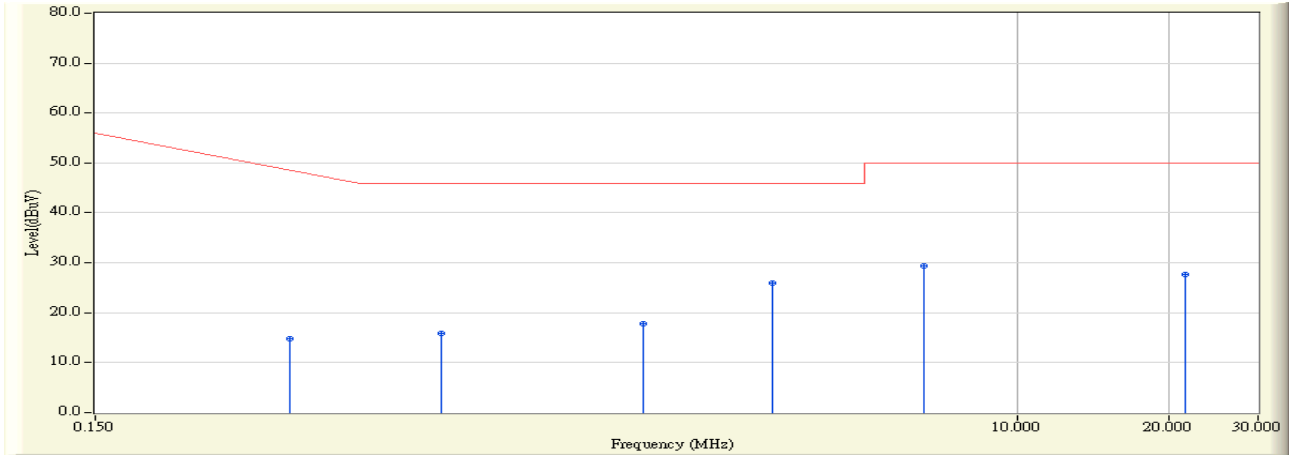

	Frequency (MHz)	Correct Factor (dB)	Reading Level (dBuV)	Measure Level (dBuV)	Margin (dB)	Limit (dBuV)	Detector Type
1	0.365	0.009	14.770	14.779	-35.078	49.857	AVERAGE
2	0.726	0.040	15.850	15.890	-30.110	46.000	AVERAGE
3	1.822	0.110	17.630	17.740	-28.260	46.000	AVERAGE
4	* 3.275	0.180	25.670	25.850	-20.150	46.000	AVERAGE
5	6.552	0.330	29.020	29.350	-20.650	50.000	AVERAGE
6	21.466	0.920	26.720	27.640	-22.360	50.000	AVERAGE

Note:

1. All Reading Levels are Quasi-Peak and average value.
2. " * ", means this data is the worst emission level.
3. Measurement Level = Reading Level + Correct Factor.

Site : ShieldingRoom3	Time : 2008/06/26 - 15:34
Limit : CISPR_B_00M_QP	Margin : 0
Probe : SR3_LISN(16A) - Line2	Power : AC 120V/60Hz
EUT : WIRELESS G ADSL2+ MODEM ROUTER	Note : Mode 1: Transmit (AMIGO)-N-40M

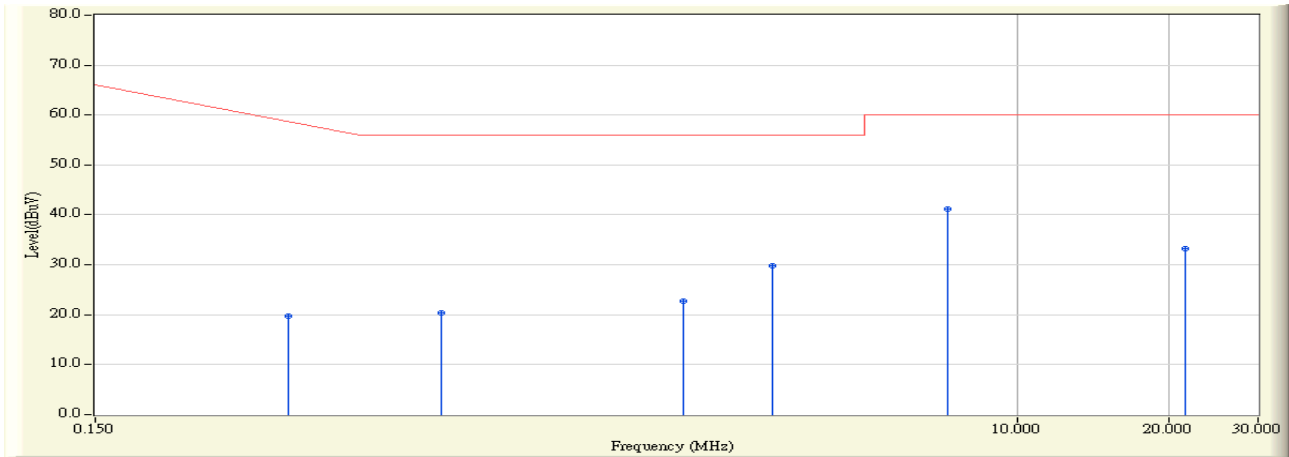

	Frequency (MHz)	Correct Factor (dB)	Reading Level (dBuV)	Measure Level (dBuV)	Margin (dB)	Limit (dBuV)	Detector Type
1	0.361	0.017	19.810	19.827	-40.144	59.971	QUASPEAK
2	0.728	0.059	20.380	20.440	-35.560	56.000	QUASPEAK
3	2.181	0.160	22.620	22.780	-33.220	56.000	QUASPEAK
4	3.275	0.220	29.540	29.760	-26.240	56.000	QUASPEAK
5	* 7.275	0.410	40.760	41.170	-18.830	60.000	QUASPEAK
6	21.467	1.000	32.160	33.160	-26.840	60.000	QUASPEAK

Note:

1. All Reading Levels are Quasi-Peak and average value.
2. " * ", means this data is the worst emission level.
3. Measurement Level = Reading Level + Correct Factor.

Site : ShieldingRoom3	Time : 2008/06/26 - 15:34
Limit : CISPR_B_00M_AV	Margin : 0
Probe : SR3_LISN(16A) - Line2	Power : AC 120V/60Hz
EUT : WIRELESS G ADSL2+ MODEM ROUTER	Note : Mode 1: Transmit (AMIGO)-N-40M

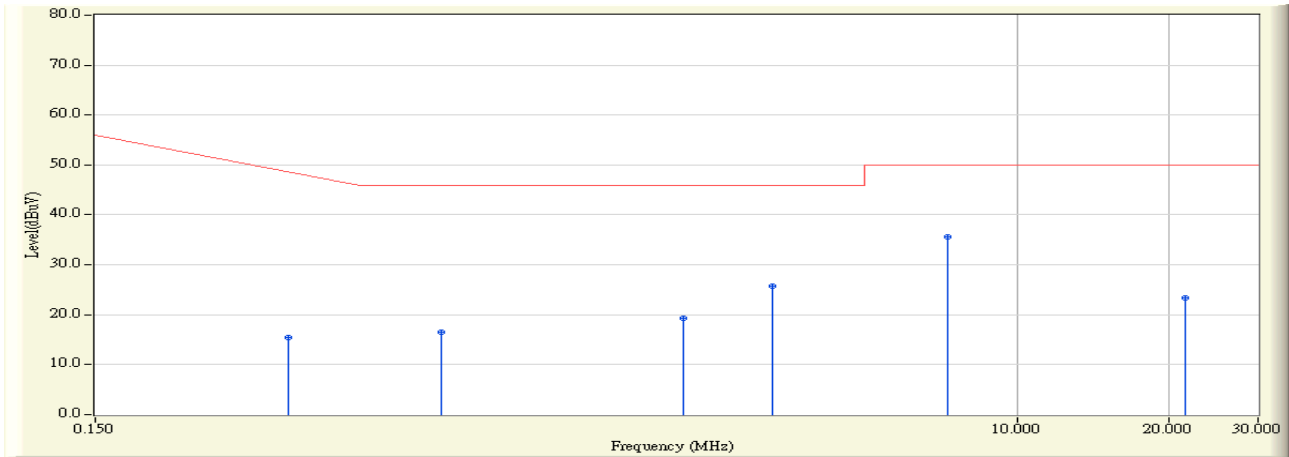

	Frequency (MHz)	Correct Factor (dB)	Reading Level (dBuV)	Measure Level (dBuV)	Margin (dB)	Limit (dBuV)	Detector Type
1	0.361	0.017	15.420	15.437	-34.534	49.971	AVERAGE
2	0.728	0.059	16.460	16.520	-29.480	46.000	AVERAGE
3	2.181	0.160	19.090	19.250	-26.750	46.000	AVERAGE
4	3.275	0.220	25.540	25.760	-20.240	46.000	AVERAGE
5	* 7.275	0.410	35.150	35.560	-14.440	50.000	AVERAGE
6	21.467	1.000	22.370	23.370	-26.630	50.000	AVERAGE

Note:

1. All Reading Levels are Quasi-Peak and average value.
2. " * ", means this data is the worst emission level.
3. Measurement Level = Reading Level + Correct Factor.

Site : ShieldingRoom3	Time : 2008/06/26 - 17:09
Limit : CISPR_B_00M_QP	Margin : 0
Probe : SR3_LISN(16A) - Line1	Power : AC 120V/60Hz
EUT : WIRELESS G ADSL2+ MODEM ROUTER	Note : Mode 2: Transmit (FAIRWAY)-B

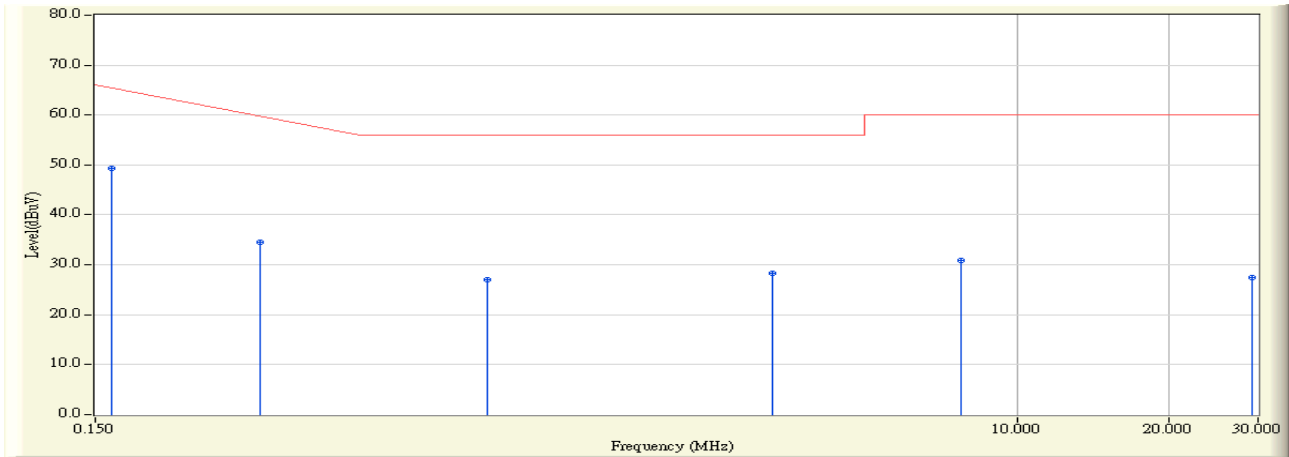

		Frequency (MHz)	Correct Factor (dB)	Reading Level (dBuV)	Measure Level (dBuV)	Margin (dB)	Limit (dBuV)	Detector Type
1	*	0.162	-0.030	49.370	49.340	-16.317	65.657	QUASPEAK
2		0.318	-0.007	34.480	34.473	-26.727	61.200	QUASPEAK
3		0.896	0.050	27.020	27.070	-28.930	56.000	QUASPEAK
4		3.291	0.180	28.190	28.370	-27.630	56.000	QUASPEAK
5		7.735	0.383	30.450	30.833	-29.167	60.000	QUASPEAK
6		29.111	1.000	26.480	27.480	-32.520	60.000	QUASPEAK

Note:

1. All Reading Levels are Quasi-Peak and average value.
2. " * ", means this data is the worst emission level.
3. Measurement Level = Reading Level + Correct Factor.

Site : ShieldingRoom3	Time : 2008/06/26 - 17:09
Limit : CISPR_B_00M_AV	Margin : 0
Probe : SR3_LISN(16A) - Line1	Power : AC 120V/60Hz
EUT : WIRELESS G ADSL2+ MODEM ROUTER	Note : Mode 2: Transmit (FAIRWAY)-B

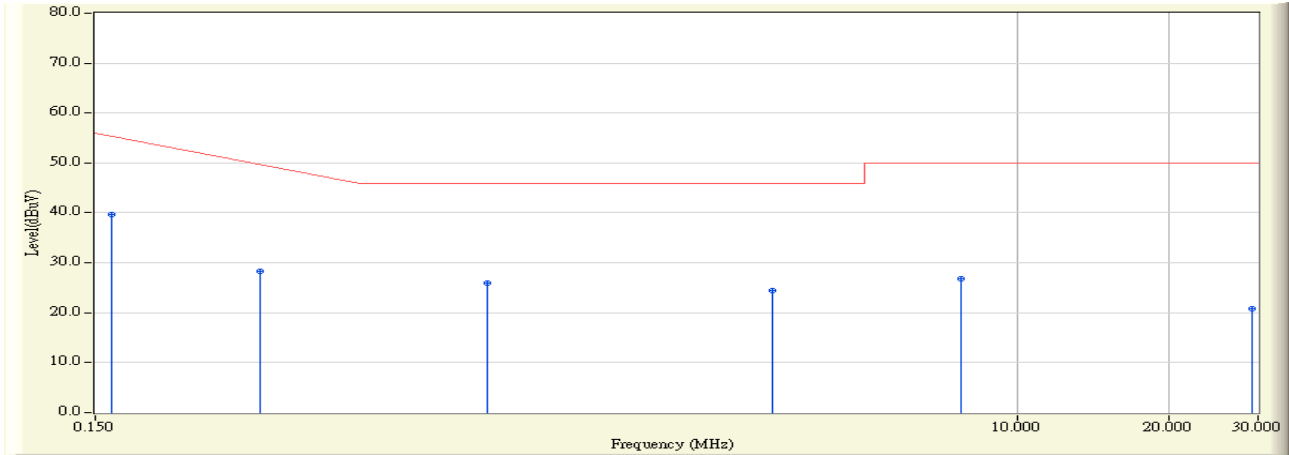

		Frequency (MHz)	Correct Factor (dB)	Reading Level (dBuV)	Measure Level (dBuV)	Margin (dB)	Limit (dBuV)	Detector Type
1	*	0.162	-0.030	39.800	39.770	-15.887	55.657	AVERAGE
2		0.318	-0.007	28.380	28.373	-22.827	51.200	AVERAGE
3		0.896	0.050	25.950	26.000	-20.000	46.000	AVERAGE
4		3.291	0.180	24.310	24.490	-21.510	46.000	AVERAGE
5		7.735	0.383	26.500	26.883	-23.117	50.000	AVERAGE
6		29.111	1.000	19.880	20.880	-29.120	50.000	AVERAGE

Note:

1. All Reading Levels are Quasi-Peak and average value.
2. " * ", means this data is the worst emission level.
3. Measurement Level = Reading Level + Correct Factor.

Site : ShieldingRoom3	Time : 2008/06/26 - 17:12
Limit : CISPR_B_00M_QP	Margin : 0
Probe : SR3_LISN(16A) - Line2	Power : AC 120V/60Hz
EUT : WIRELESS G ADSL2+ MODEM ROUTER	Note : Mode 2: Transmit (FAIRWAY)-B

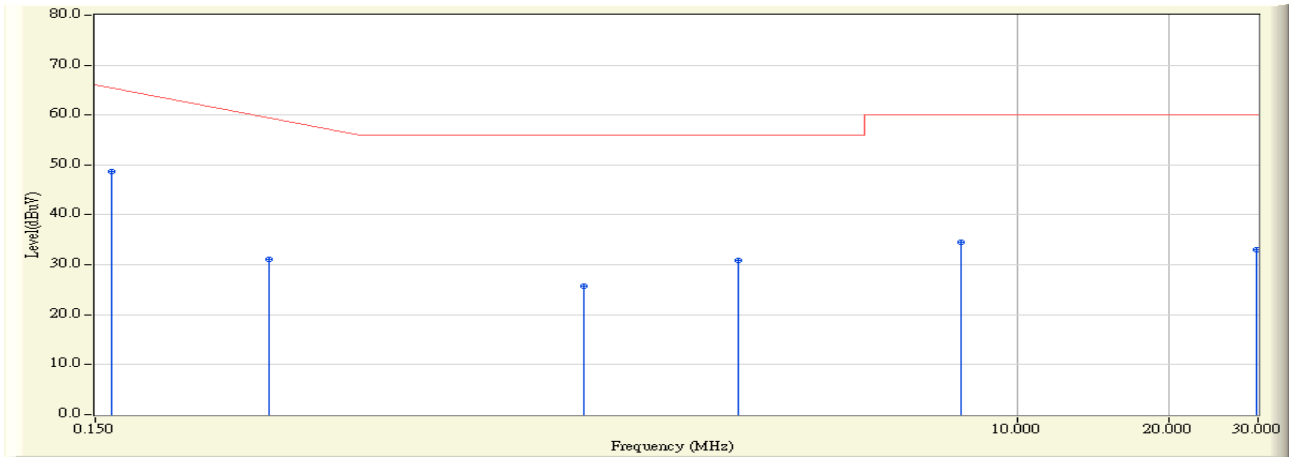

		Frequency (MHz)	Correct Factor (dB)	Reading Level (dBuV)	Measure Level (dBuV)	Margin (dB)	Limit (dBuV)	Detector Type
1	*	0.162	-0.030	48.720	48.690	-16.967	65.657	QUASPEAK
2		0.330	0.007	31.180	31.187	-29.670	60.857	QUASPEAK
3		1.388	0.110	25.550	25.660	-30.340	56.000	QUASPEAK
4		2.806	0.200	30.580	30.780	-25.220	56.000	QUASPEAK
5		7.728	0.421	34.150	34.571	-25.429	60.000	QUASPEAK
6		29.806	1.060	31.870	32.930	-27.070	60.000	QUASPEAK

Note:

1. All Reading Levels are Quasi-Peak and average value.
2. " * ", means this data is the worst emission level.
3. Measurement Level = Reading Level + Correct Factor.

Site : ShieldingRoom3	Time : 2008/06/26 - 17:12
Limit : CISPR_B_00M_AV	Margin : 0
Probe : SR3_LISN(16A) - Line2	Power : AC 120V/60Hz
EUT : WIRELESS G ADSL2+ MODEM ROUTER	Note : Mode 2: Transmit (FAIRWAY)-B

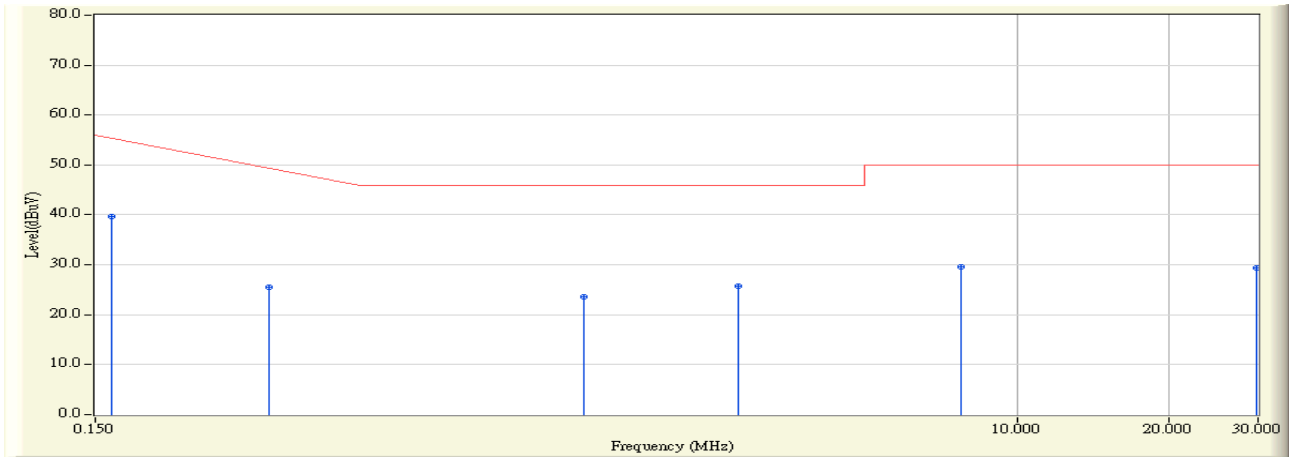

		Frequency (MHz)	Correct Factor (dB)	Reading Level (dBuV)	Measure Level (dBuV)	Margin (dB)	Limit (dBuV)	Detector Type
1	*	0.162	-0.030	39.620	39.590	-16.067	55.657	AVERAGE
2		0.330	0.007	25.470	25.477	-25.380	50.857	AVERAGE
3		1.388	0.110	23.520	23.630	-22.370	46.000	AVERAGE
4		2.806	0.200	25.520	25.720	-20.280	46.000	AVERAGE
5		7.728	0.421	29.240	29.661	-20.339	50.000	AVERAGE
6		29.806	1.060	28.370	29.430	-20.570	50.000	AVERAGE

Note:

1. All Reading Levels are Quasi-Peak and average value.
2. " * ", means this data is the worst emission level.
3. Measurement Level = Reading Level + Correct Factor.

Site : ShieldingRoom3	Time : 2008/06/26 - 17:16
Limit : CISPR_B_00M_QP	Margin : 0
Probe : SR3_LISN(16A) - Line1	Power : AC 120V/60Hz
EUT : WIRELESS G ADSL2+ MODEM ROUTER	Note : Mode 2: Transmit (FAIRWAY)-G

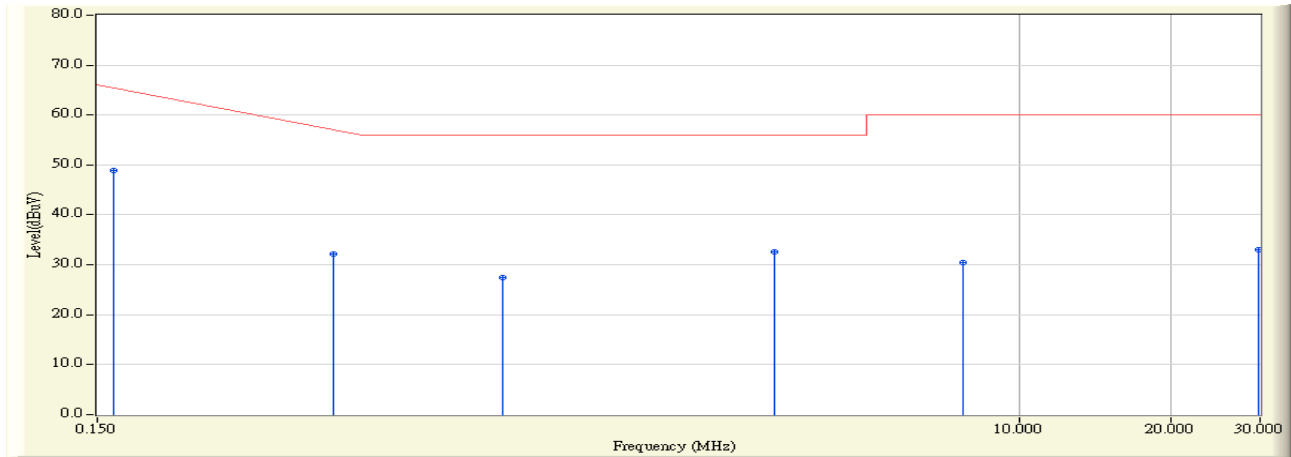

		Frequency (MHz)	Correct Factor (dB)	Reading Level (dBuV)	Measure Level (dBuV)	Margin (dB)	Limit (dBuV)	Detector Type
1	*	0.162	-0.030	48.960	48.930	-16.727	65.657	QUASPEAK
2		0.439	0.020	32.050	32.070	-25.673	57.743	QUASPEAK
3		0.951	0.060	27.320	27.380	-28.620	56.000	QUASPEAK
4		3.283	0.180	32.430	32.610	-23.390	56.000	QUASPEAK
5		7.728	0.381	30.050	30.431	-29.569	60.000	QUASPEAK
6		29.806	1.010	31.970	32.980	-27.020	60.000	QUASPEAK

Note:

1. All Reading Levels are Quasi-Peak and average value.
2. " * ", means this data is the worst emission level.
3. Measurement Level = Reading Level + Correct Factor.

Site : ShieldingRoom3	Time : 2008/06/26 - 17:16
Limit : CISPR_B_00M_AV	Margin : 0
Probe : SR3_LISN(16A) - Line1	Power : AC 120V/60Hz
EUT : WIRELESS G ADSL2+ MODEM ROUTER	Note : Mode 2: Transmit (FAIRWAY)-G

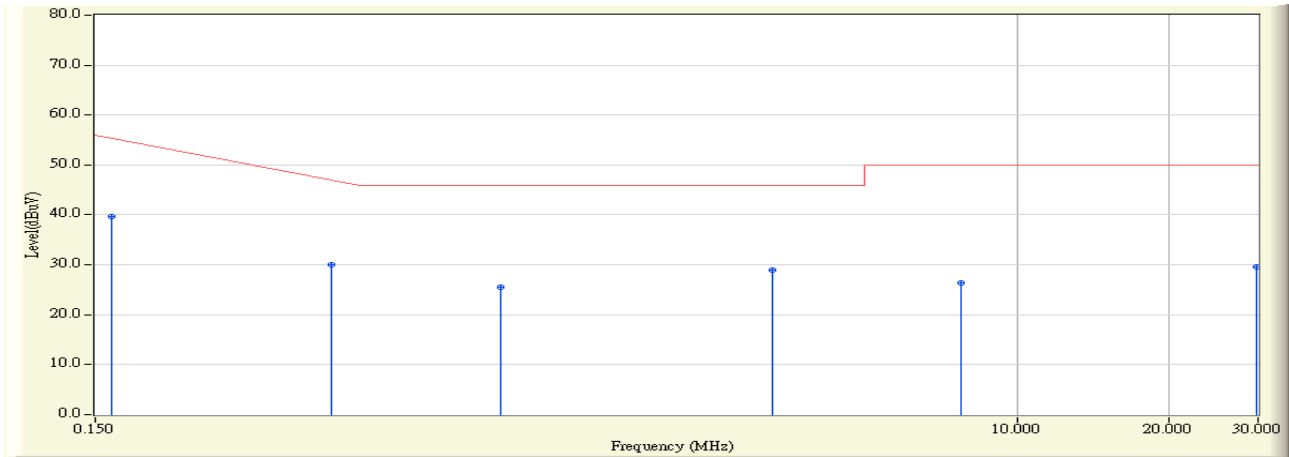

		Frequency (MHz)	Correct Factor (dB)	Reading Level (dBuV)	Measure Level (dBuV)	Margin (dB)	Limit (dBuV)	Detector Type
1	*	0.162	-0.030	39.620	39.590	-16.067	55.657	AVERAGE
2		0.439	0.020	30.080	30.100	-17.643	47.743	AVERAGE
3		0.951	0.060	25.520	25.580	-20.420	46.000	AVERAGE
4		3.283	0.180	28.690	28.870	-17.130	46.000	AVERAGE
5		7.728	0.381	25.940	26.321	-23.679	50.000	AVERAGE
6		29.806	1.010	28.500	29.510	-20.490	50.000	AVERAGE

Note:

1. All Reading Levels are Quasi-Peak and average value.
2. " * ", means this data is the worst emission level.
3. Measurement Level = Reading Level + Correct Factor.

Site : ShieldingRoom3	Time : 2008/06/26 - 17:20
Limit : CISPR_B_00M_QP	Margin : 0
Probe : SR3_LISN(16A) - Line2	Power : AC 120V/60Hz
EUT : WIRELESS G ADSL2+ MODEM ROUTER	Note : Mode 2: Transmit (FAIRWAY)-G

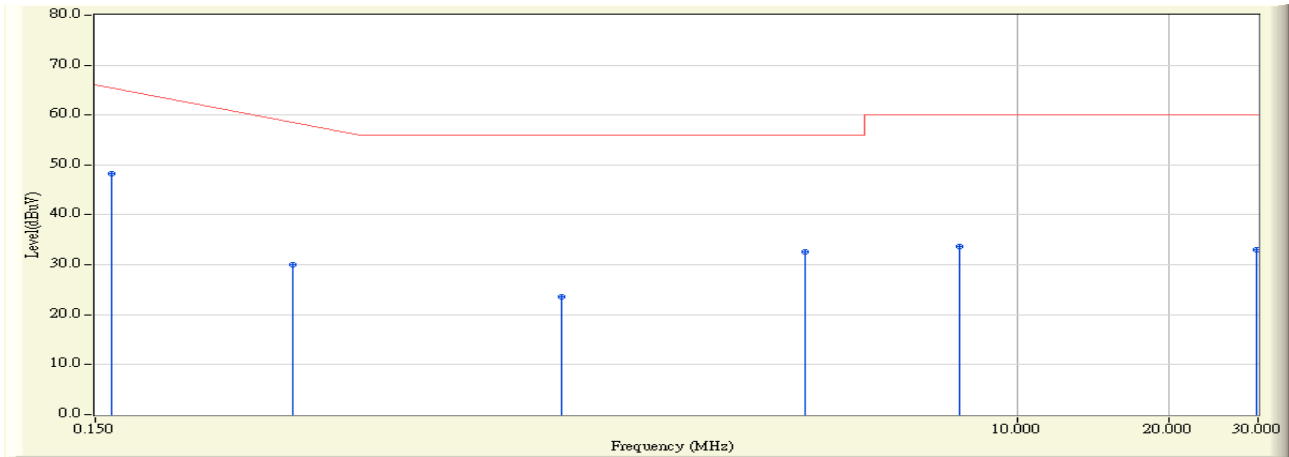

		Frequency (MHz)	Correct Factor (dB)	Reading Level (dBuV)	Measure Level (dBuV)	Margin (dB)	Limit (dBuV)	Detector Type
1	*	0.162	-0.030	48.320	48.290	-17.367	65.657	QUASPEAK
2		0.369	0.020	30.040	30.060	-29.683	59.743	QUASPEAK
3		1.252	0.099	23.480	23.579	-32.421	56.000	QUASPEAK
4		3.802	0.245	32.290	32.535	-23.465	56.000	QUASPEAK
5		7.724	0.420	33.350	33.770	-26.230	60.000	QUASPEAK
6		29.806	1.060	31.950	33.010	-26.990	60.000	QUASPEAK

Note:

1. All Reading Levels are Quasi-Peak and average value.
2. " * ", means this data is the worst emission level.
3. Measurement Level = Reading Level + Correct Factor.

Site : ShieldingRoom3	Time : 2008/06/26 - 17:20
Limit : CISPR_B_00M_AV	Margin : 0
Probe : SR3_LISN(16A) - Line2	Power : AC 120V/60Hz
EUT : WIRELESS G ADSL2+ MODEM ROUTER	Note : Mode 2: Transmit (FAIRWAY)-G

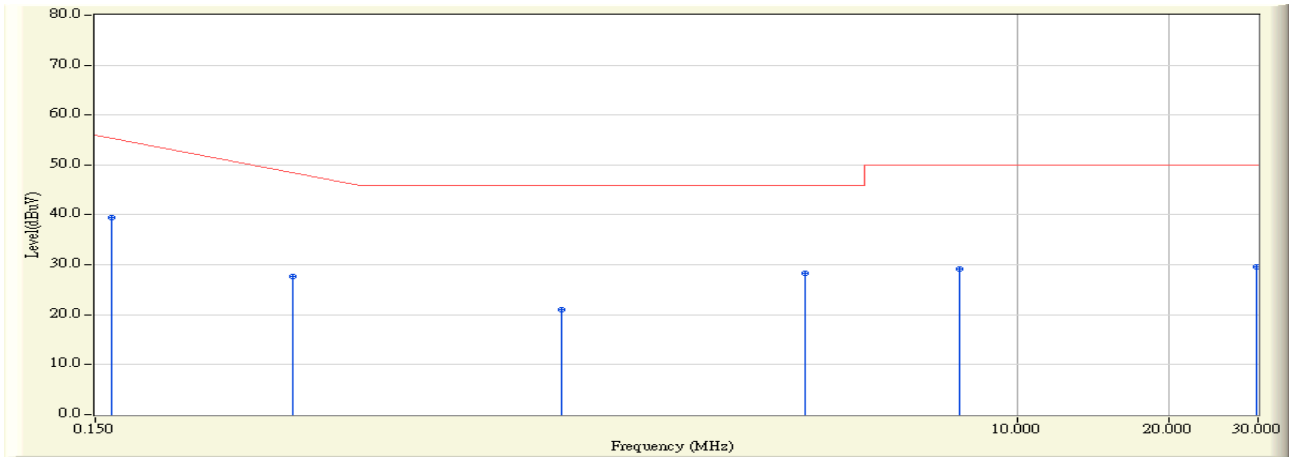

		Frequency (MHz)	Correct Factor (dB)	Reading Level (dBuV)	Measure Level (dBuV)	Margin (dB)	Limit (dBuV)	Detector Type
1	*	0.162	-0.030	39.420	39.390	-16.267	55.657	AVERAGE
2		0.369	0.020	27.640	27.660	-22.083	49.743	AVERAGE
3		1.252	0.099	20.900	20.999	-25.001	46.000	AVERAGE
4		3.802	0.245	28.060	28.305	-17.695	46.000	AVERAGE
5		7.724	0.420	28.820	29.240	-20.760	50.000	AVERAGE
6		29.806	1.060	28.500	29.560	-20.440	50.000	AVERAGE

Note:

1. All Reading Levels are Quasi-Peak and average value.
2. " * ", means this data is the worst emission level.
3. Measurement Level = Reading Level + Correct Factor.

Site : ShieldingRoom3	Time : 2008/06/26 - 17:25
Limit : CISPR_B_00M_QP	Margin : 0
Probe : SR3_LISN(16A) - Line1	Power : AC 120V/60Hz
EUT : WIRELESS G ADSL2+ MODEM ROUTER	Note : Mode 2: Transmit (FAIRWAY)-N-20M

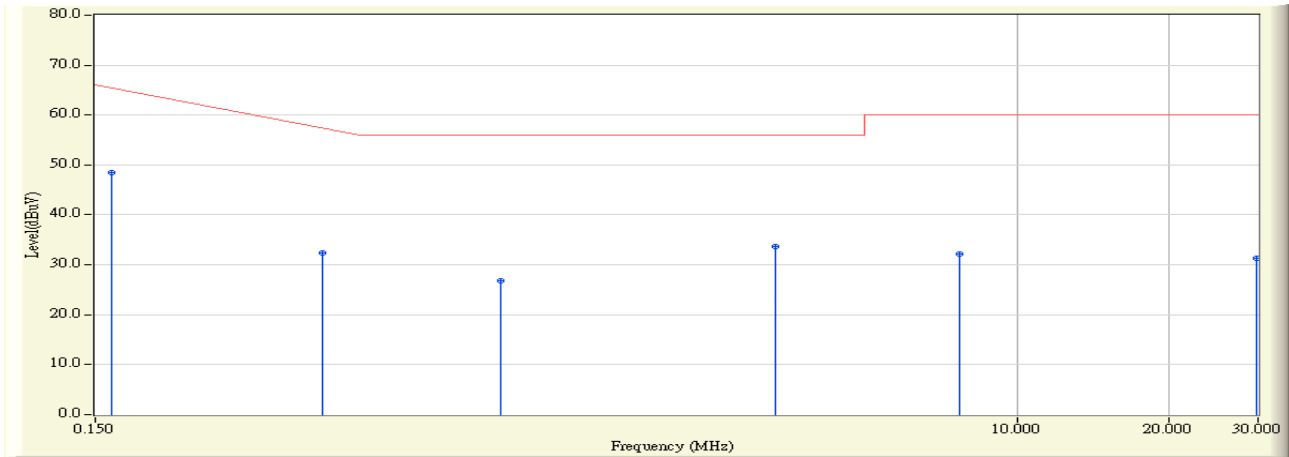

		Frequency (MHz)	Correct Factor (dB)	Reading Level (dBuV)	Measure Level (dBuV)	Margin (dB)	Limit (dBuV)	Detector Type
1	*	0.162	-0.030	48.460	48.430	-17.227	65.657	QUASPEAK
2		0.423	0.018	32.400	32.418	-25.782	58.200	QUASPEAK
3		0.951	0.060	26.850	26.910	-29.090	56.000	QUASPEAK
4		3.326	0.180	33.600	33.780	-22.220	56.000	QUASPEAK
5		7.724	0.380	31.800	32.180	-27.820	60.000	QUASPEAK
6		29.810	1.010	30.270	31.280	-28.720	60.000	QUASPEAK

Note:

1. All Reading Levels are Quasi-Peak and average value.
2. " * ", means this data is the worst emission level.
3. Measurement Level = Reading Level + Correct Factor.

Site : ShieldingRoom3	Time : 2008/06/26 - 17:25
Limit : CISPR_B_00M_AV	Margin : 0
Probe : SR3_LISN(16A) - Line1	Power : AC 120V/60Hz
EUT : WIRELESS G ADSL2+ MODEM ROUTER	Note : Mode 2: Transmit (FAIRWAY)-N-20M

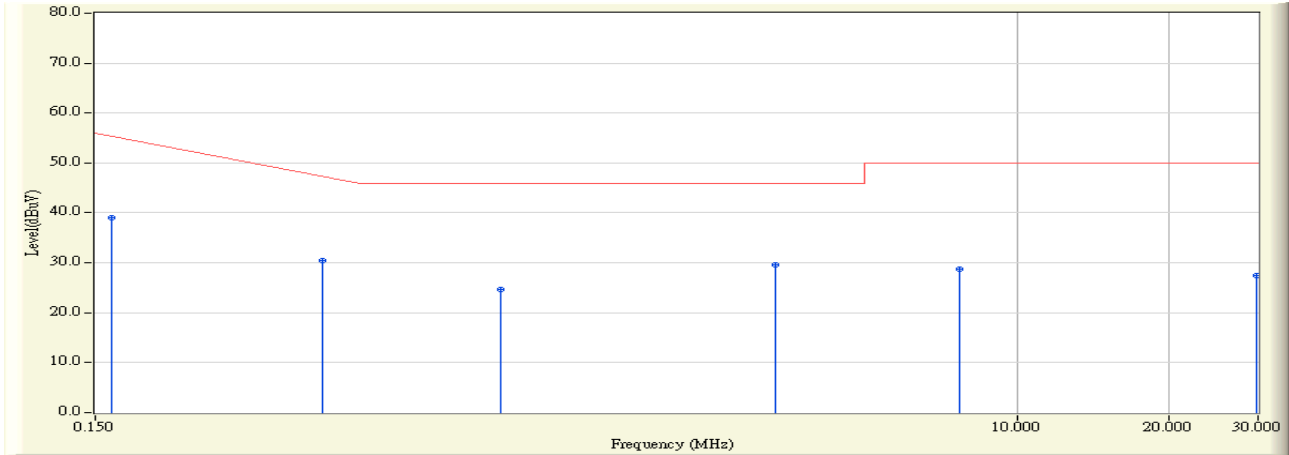

	Frequency (MHz)	Correct Factor (dB)	Reading Level (dBuV)	Measure Level (dBuV)	Margin (dB)	Limit (dBuV)	Detector Type
1	0.162	-0.030	39.030	39.000	-16.657	55.657	AVERAGE
2	0.423	0.018	30.450	30.468	-17.732	48.200	AVERAGE
3	0.951	0.060	24.670	24.730	-21.270	46.000	AVERAGE
4	* 3.326	0.180	29.480	29.660	-16.340	46.000	AVERAGE
5	7.724	0.380	28.340	28.720	-21.280	50.000	AVERAGE
6	29.810	1.010	26.520	27.530	-22.470	50.000	AVERAGE

Note:

1. All Reading Levels are Quasi-Peak and average value.
2. " * ", means this data is the worst emission level.
3. Measurement Level = Reading Level + Correct Factor.

Site : ShieldingRoom3	Time : 2008/06/26 - 17:29
Limit : CISPR_B_00M_QP	Margin : 0
Probe : SR3_LISN(16A) - Line2	Power : AC 120V/60Hz
EUT : WIRELESS G ADSL2+ MODEM ROUTER	Note : Mode 2: Transmit (FAIRWAY)-N-20M

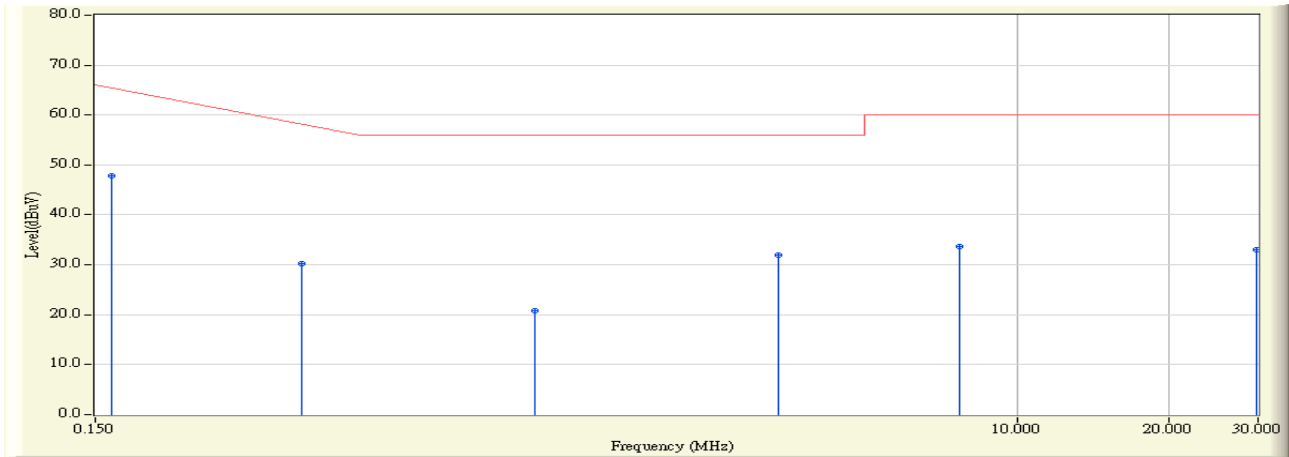

		Frequency (MHz)	Correct Factor (dB)	Reading Level (dBuV)	Measure Level (dBuV)	Margin (dB)	Limit (dBuV)	Detector Type
1	*	0.162	-0.030	47.930	47.900	-17.757	65.657	QUASPEAK
2		0.384	0.020	30.140	30.160	-29.154	59.314	QUASPEAK
3		1.111	0.090	20.810	20.900	-35.100	56.000	QUASPEAK
4		3.380	0.220	31.820	32.040	-23.960	56.000	QUASPEAK
5		7.716	0.420	33.330	33.750	-26.250	60.000	QUASPEAK
6		29.806	1.060	32.040	33.100	-26.900	60.000	QUASPEAK

Note:

1. All Reading Levels are Quasi-Peak and average value.
2. " * ", means this data is the worst emission level.
3. Measurement Level = Reading Level + Correct Factor.

Site : ShieldingRoom3	Time : 2008/06/26 - 17:29
Limit : CISPR_B_00M_AV	Margin : 0
Probe : SR3_LISN(16A) - Line2	Power : AC 120V/60Hz
EUT : WIRELESS G ADSL2+ MODEM ROUTER	Note : Mode 2: Transmit (FAIRWAY)-N-20M

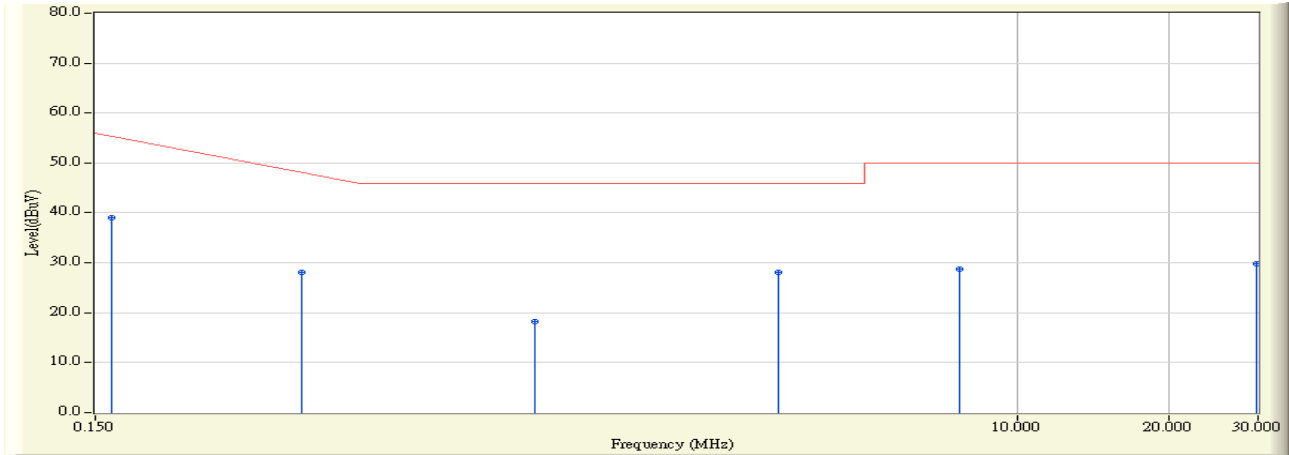

		Frequency (MHz)	Correct Factor (dB)	Reading Level (dBuV)	Measure Level (dBuV)	Margin (dB)	Limit (dBuV)	Detector Type
1	*	0.162	-0.030	39.120	39.090	-16.567	55.657	AVERAGE
2		0.384	0.020	28.050	28.070	-21.244	49.314	AVERAGE
3		1.111	0.090	18.120	18.210	-27.790	46.000	AVERAGE
4		3.380	0.220	27.940	28.160	-17.840	46.000	AVERAGE
5		7.716	0.420	28.250	28.670	-21.330	50.000	AVERAGE
6		29.806	1.060	28.680	29.740	-20.260	50.000	AVERAGE

Note:

1. All Reading Levels are Quasi-Peak and average value.
2. " * ", means this data is the worst emission level.
3. Measurement Level = Reading Level + Correct Factor.

Site : ShieldingRoom3	Time : 2008/06/26 - 17:34
Limit : CISPR_B_00M_QP	Margin : 0
Probe : SR3_LISN(16A) - Line1	Power : AC 120V/60Hz
EUT : WIRELESS G ADSL2+ MODEM ROUTER	Note : Mode 2: Transmit (FAIRWAY)- N-40M

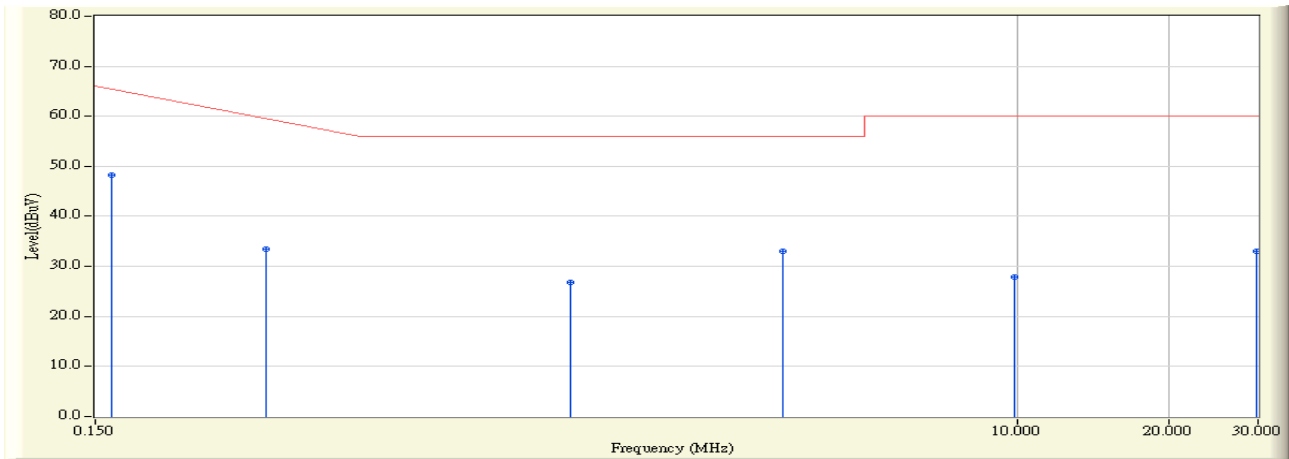

		Frequency (MHz)	Correct Factor (dB)	Reading Level (dBuV)	Measure Level (dBuV)	Margin (dB)	Limit (dBuV)	Detector Type
1	*	0.162	-0.030	48.200	48.170	-17.487	65.657	QUASPEAK
2		0.326	-0.004	33.540	33.536	-27.435	60.971	QUASPEAK
3		1.306	0.080	26.830	26.910	-29.090	56.000	QUASPEAK
4		3.431	0.190	32.740	32.930	-23.070	56.000	QUASPEAK
5		9.922	0.490	27.330	27.820	-32.180	60.000	QUASPEAK
6		29.806	1.010	32.080	33.090	-26.910	60.000	QUASPEAK

Note:

1. All Reading Levels are Quasi-Peak and average value.
2. " * ", means this data is the worst emission level.
3. Measurement Level = Reading Level + Correct Factor.

Site : ShieldingRoom3	Time : 2008/06/26 - 17:34
Limit : CISPR_B_00M_AV	Margin : 0
Probe : SR3_LISN(16A) - Line1	Power : AC 120V/60Hz
EUT : WIRELESS G ADSL2+ MODEM ROUTER	Note : Mode 2: Transmit (FAIRWAY)- N-40M

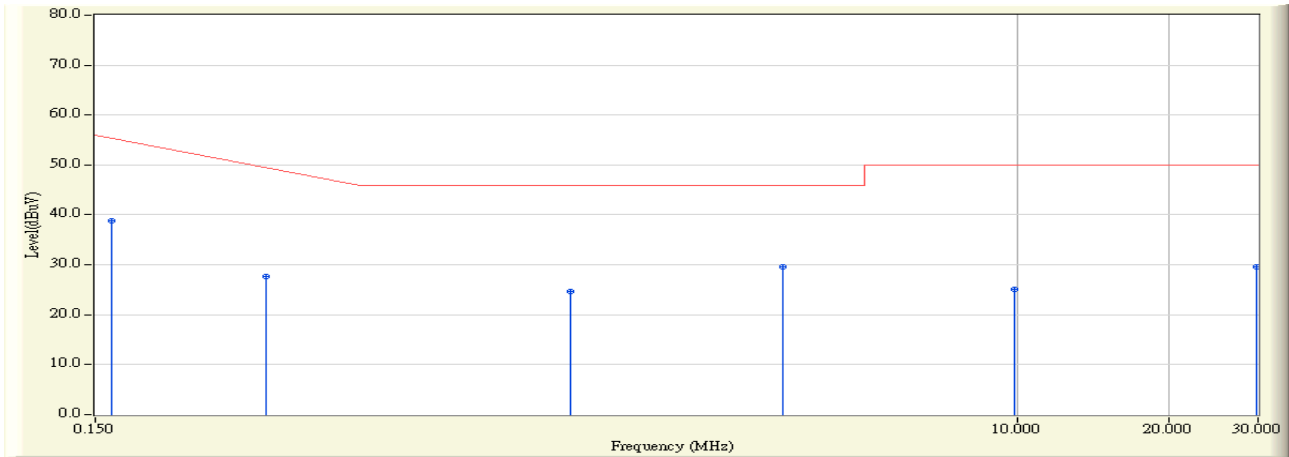

	Frequency (MHz)	Correct Factor (dB)	Reading Level (dBuV)	Measure Level (dBuV)	Margin (dB)	Limit (dBuV)	Detector Type
1	0.162	-0.030	38.820	38.790	-16.867	55.657	AVERAGE
2	0.326	-0.004	27.570	27.566	-23.405	50.971	AVERAGE
3	1.306	0.080	24.630	24.710	-21.290	46.000	AVERAGE
4	* 3.431	0.190	29.430	29.620	-16.380	46.000	AVERAGE
5	9.922	0.490	24.600	25.090	-24.910	50.000	AVERAGE
6	29.806	1.010	28.680	29.690	-20.310	50.000	AVERAGE

Note:

1. All Reading Levels are Quasi-Peak and average value.
2. " * ", means this data is the worst emission level.
3. Measurement Level = Reading Level + Correct Factor.

Site : ShieldingRoom3	Time : 2008/06/26 - 17:38
Limit : CISPR_B_00M_QP	Margin : 0
Probe : SR3_LISN(16A) - Line2	Power : AC 120V/60Hz
EUT : WIRELESS G ADSL2+ MODEM ROUTER	Note : Mode 2: Transmit (FAIRWAY)- N-40M

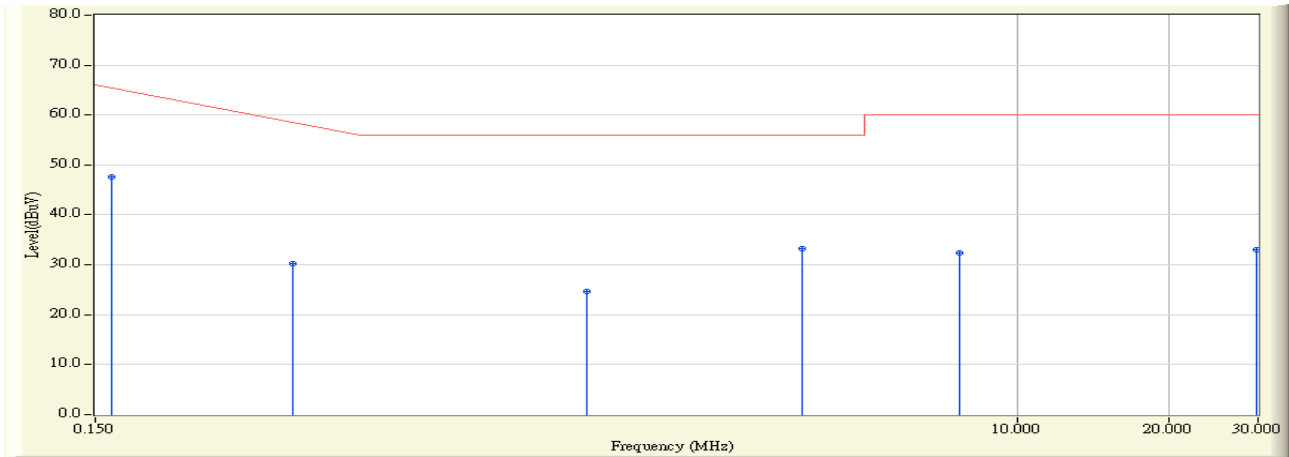

		Frequency (MHz)	Correct Factor (dB)	Reading Level (dBuV)	Measure Level (dBuV)	Margin (dB)	Limit (dBuV)	Detector Type
1	*	0.162	-0.030	47.710	47.680	-17.977	65.657	QUASPEAK
2		0.369	0.020	30.160	30.180	-29.563	59.743	QUASPEAK
3		1.412	0.110	24.500	24.610	-31.390	56.000	QUASPEAK
4		3.748	0.230	32.940	33.170	-22.830	56.000	QUASPEAK
5		7.720	0.420	31.960	32.380	-27.620	60.000	QUASPEAK
6		29.806	1.060	31.910	32.970	-27.030	60.000	QUASPEAK

Note:

1. All Reading Levels are Quasi-Peak and average value.
2. " * ", means this data is the worst emission level.
3. Measurement Level = Reading Level + Correct Factor.

Site : ShieldingRoom3	Time : 2008/06/26 - 17:38
Limit : CISPR_B_00M_AV	Margin : 0
Probe : SR3_LISN(16A) - Line2	Power : AC 120V/60Hz
EUT : WIRELESS G ADSL2+ MODEM ROUTER	Note : Mode 2: Transmit (FAIRWAY)- N-40M

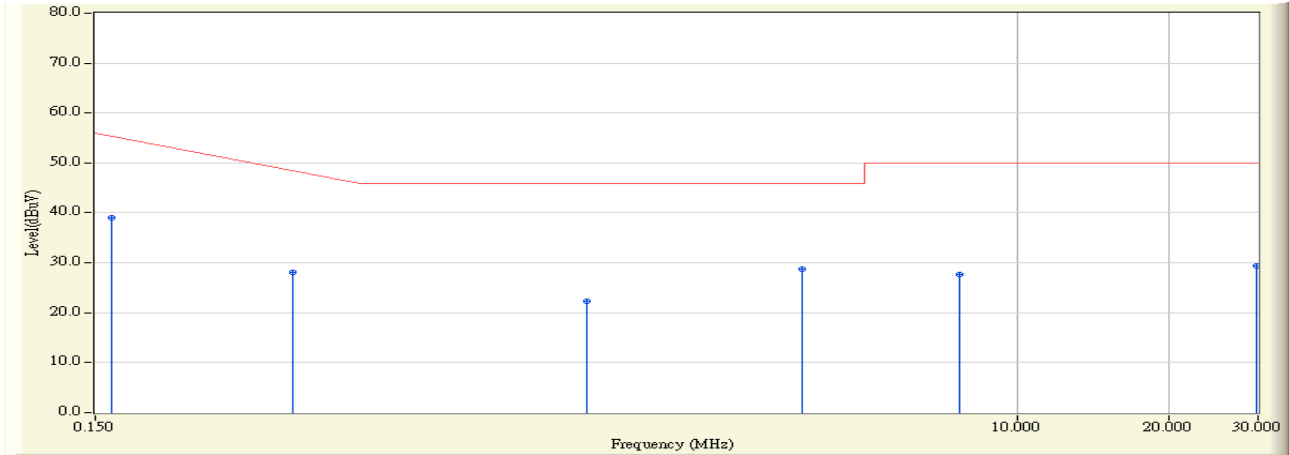

		Frequency (MHz)	Correct Factor (dB)	Reading Level (dBuV)	Measure Level (dBuV)	Margin (dB)	Limit (dBuV)	Detector Type
1	*	0.162	-0.030	39.030	39.000	-16.657	55.657	AVERAGE
2		0.369	0.020	27.970	27.990	-21.753	49.743	AVERAGE
3		1.412	0.110	22.090	22.200	-23.800	46.000	AVERAGE
4		3.748	0.230	28.600	28.830	-17.170	46.000	AVERAGE
5		7.720	0.420	27.340	27.760	-22.240	50.000	AVERAGE
6		29.806	1.060	28.370	29.430	-20.570	50.000	AVERAGE

Note:

1. All Reading Levels are Quasi-Peak and average value.
2. " * ", means this data is the worst emission level.
3. Measurement Level = Reading Level + Correct Factor.

Site : ShieldingRoom3	Time : 2008/06/26 - 16:00
Limit : CISPR_B_00M_QP	Margin : 0
Probe : SR3_LISN(16A) - Line1	Power : AC 120V/60Hz
EUT : WIRELESS G ADSL2+ MODEM ROUTER	Note : Mode 3: Transmit (D-Link)-B

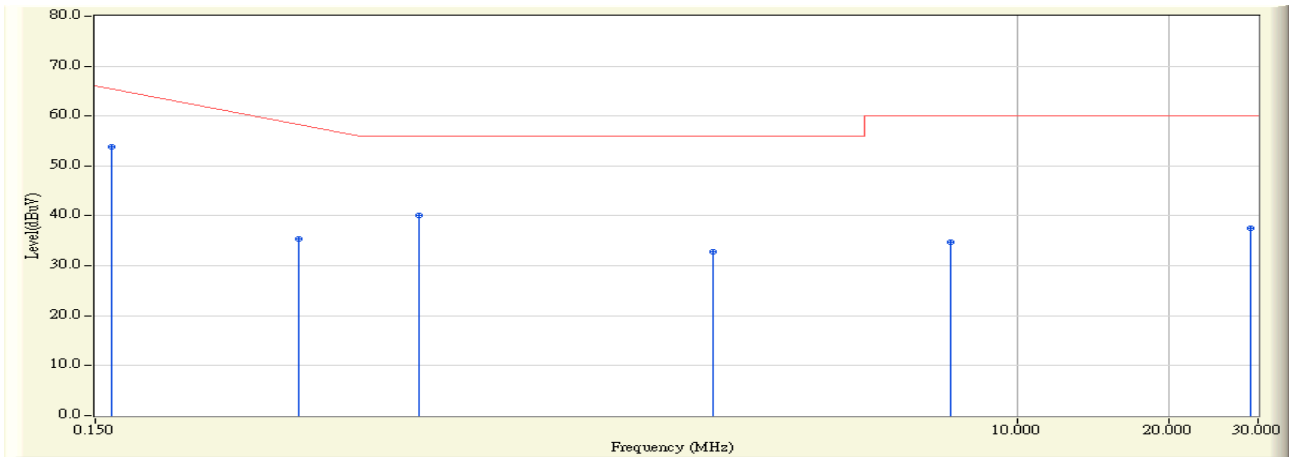

		Frequency (MHz)	Correct Factor (dB)	Reading Level (dBuV)	Measure Level (dBuV)	Margin (dB)	Limit (dBuV)	Detector Type
1	*	0.162	-0.030	53.790	53.760	-11.897	65.657	QUASPEAK
2		0.380	0.010	35.360	35.370	-24.059	59.429	QUASPEAK
3		0.654	0.040	40.170	40.210	-15.790	56.000	QUASPEAK
4		2.502	0.140	32.700	32.840	-23.160	56.000	QUASPEAK
5		7.414	0.370	34.390	34.760	-25.240	60.000	QUASPEAK
6		29.037	1.000	36.460	37.460	-22.540	60.000	QUASPEAK

Note:

1. All Reading Levels are Quasi-Peak and average value.
2. " * ", means this data is the worst emission level.
3. Measurement Level = Reading Level + Correct Factor.

Site : ShieldingRoom3	Time : 2008/06/26 - 16:00
Limit : CISPR_B_00M_AV	Margin : 0
Probe : SR3_LISN(16A) - Line1	Power : AC 120V/60Hz
EUT : WIRELESS G ADSL2+ MODEM ROUTER	Note : Mode 3: Transmit (D-Link)-B

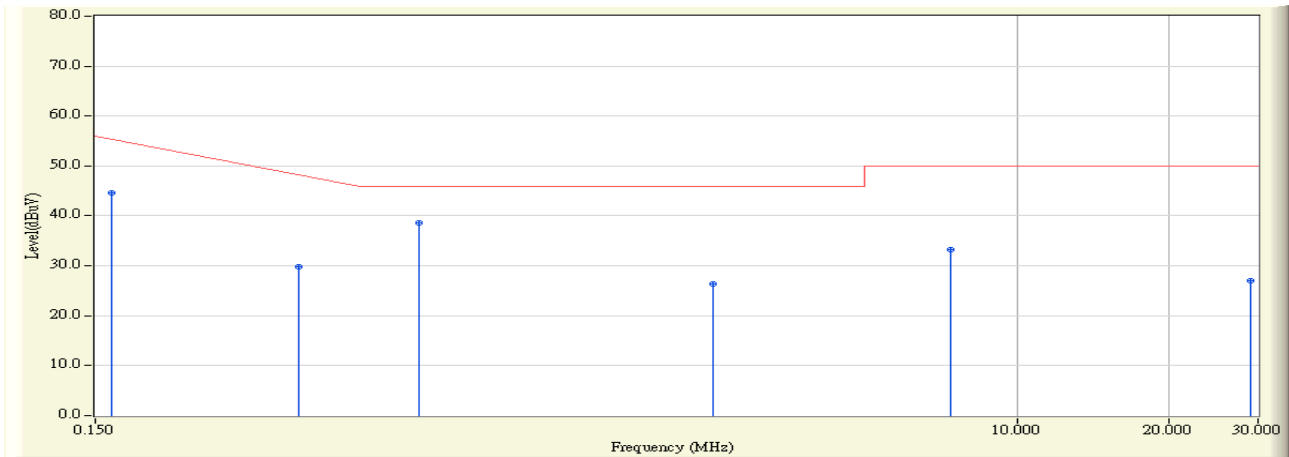

	Frequency (MHz)	Correct Factor (dB)	Reading Level (dBuV)	Measure Level (dBuV)	Margin (dB)	Limit (dBuV)	Detector Type
1	0.162	-0.030	44.740	44.710	-10.947	55.657	AVERAGE
2	0.380	0.010	29.820	29.830	-19.599	49.429	AVERAGE
3	* 0.654	0.040	38.560	38.600	-7.400	46.000	AVERAGE
4	2.502	0.140	26.140	26.280	-19.720	46.000	AVERAGE
5	7.414	0.370	32.880	33.250	-16.750	50.000	AVERAGE
6	29.037	1.000	26.060	27.060	-22.940	50.000	AVERAGE

Note:

1. All Reading Levels are Quasi-Peak and average value.
2. " * ", means this data is the worst emission level.
3. Measurement Level = Reading Level + Correct Factor.

Site : ShieldingRoom3	Time : 2008/06/26 - 16:04
Limit : CISPR_B_00M_QP	Margin : 0
Probe : SR3_LISN(16A) - Line2	Power : AC 120V/60Hz
EUT : WIRELESS G ADSL2+ MODEM ROUTER	Note : Mode 3: Transmit (D-Link)-B

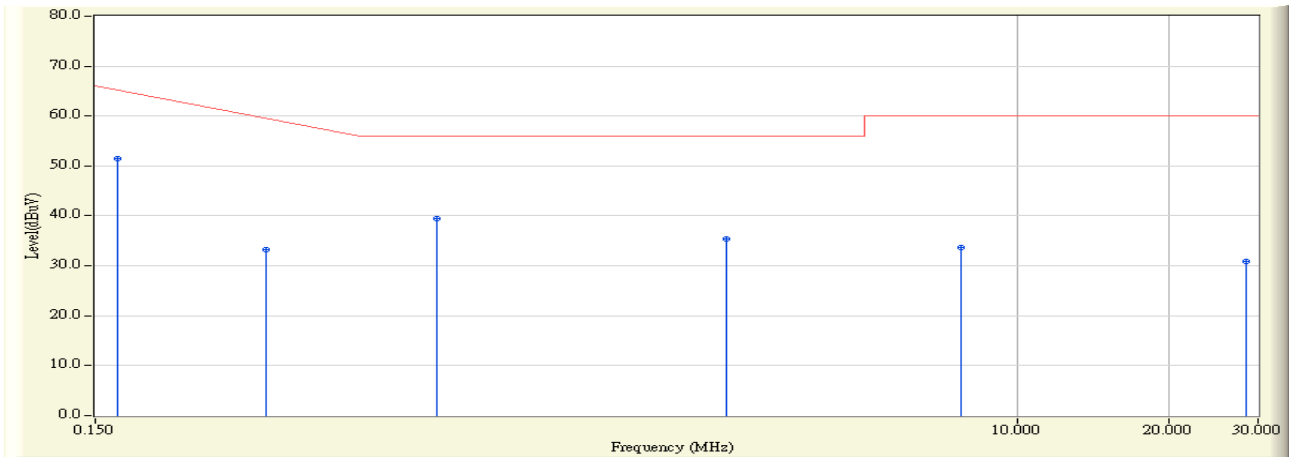

		Frequency (MHz)	Correct Factor (dB)	Reading Level (dBuV)	Measure Level (dBuV)	Margin (dB)	Limit (dBuV)	Detector Type
1	*	0.166	-0.030	51.490	51.460	-14.083	65.543	QUASPEAK
2		0.326	0.006	33.340	33.346	-27.625	60.971	QUASPEAK
3		0.709	0.053	39.510	39.563	-16.437	56.000	QUASPEAK
4		2.666	0.190	35.290	35.480	-20.520	56.000	QUASPEAK
5		7.769	0.430	33.350	33.780	-26.220	60.000	QUASPEAK
6		28.337	1.070	29.800	30.870	-29.130	60.000	QUASPEAK

Note:

1. All Reading Levels are Quasi-Peak and average value.
2. " * ", means this data is the worst emission level.
3. Measurement Level = Reading Level + Correct Factor.

Site : ShieldingRoom3	Time : 2008/06/26 - 16:04
Limit : CISPR_B_00M_AV	Margin : 0
Probe : SR3_LISN(16A) - Line2	Power : AC 120V/60Hz
EUT : WIRELESS G ADSL2+ MODEM ROUTER	Note : Mode 3: Transmit (D-Link)-B

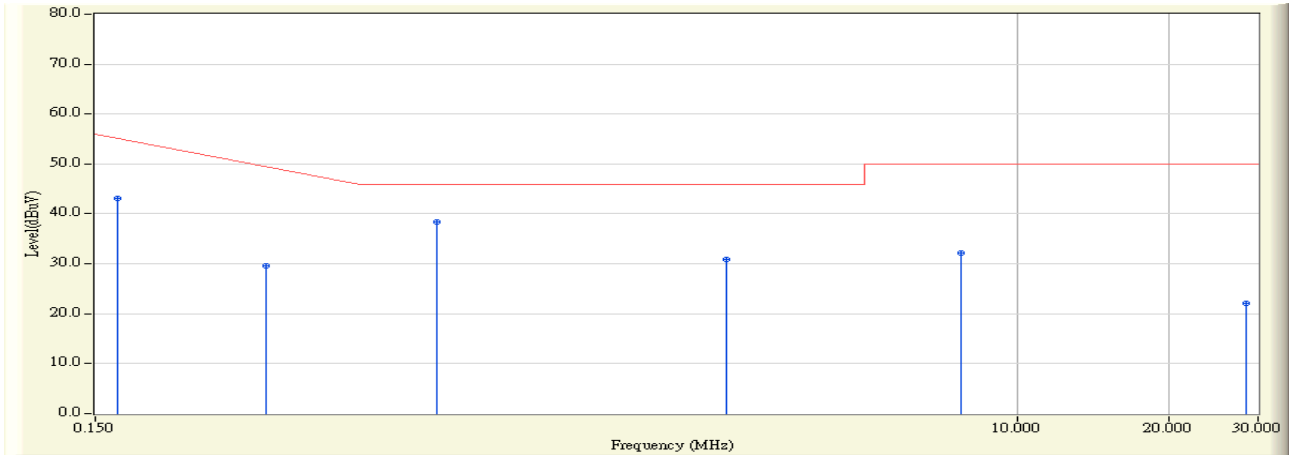

	Frequency (MHz)	Correct Factor (dB)	Reading Level (dBuV)	Measure Level (dBuV)	Margin (dB)	Limit (dBuV)	Detector Type
1	0.166	-0.030	43.140	43.110	-12.433	55.543	AVERAGE
2	0.326	0.006	29.500	29.506	-21.465	50.971	AVERAGE
3	* 0.709	0.053	38.250	38.303	-7.697	46.000	AVERAGE
4	2.666	0.190	30.720	30.910	-15.090	46.000	AVERAGE
5	7.769	0.430	31.840	32.270	-17.730	50.000	AVERAGE
6	28.337	1.070	21.120	22.190	-27.810	50.000	AVERAGE

Note:

1. All Reading Levels are Quasi-Peak and average value.
2. " * ", means this data is the worst emission level.
3. Measurement Level = Reading Level + Correct Factor.

Site : ShieldingRoom3	Time : 2008/06/26 - 16:09
Limit : CISPR_B_00M_QP	Margin : 0
Probe : SR3_LISN(16A) - Line1	Power : AC 120V/60Hz
EUT : WIRELESS G ADSL2+ MODEM ROUTER	Note : Mode 3: Transmit (D-Link) -G

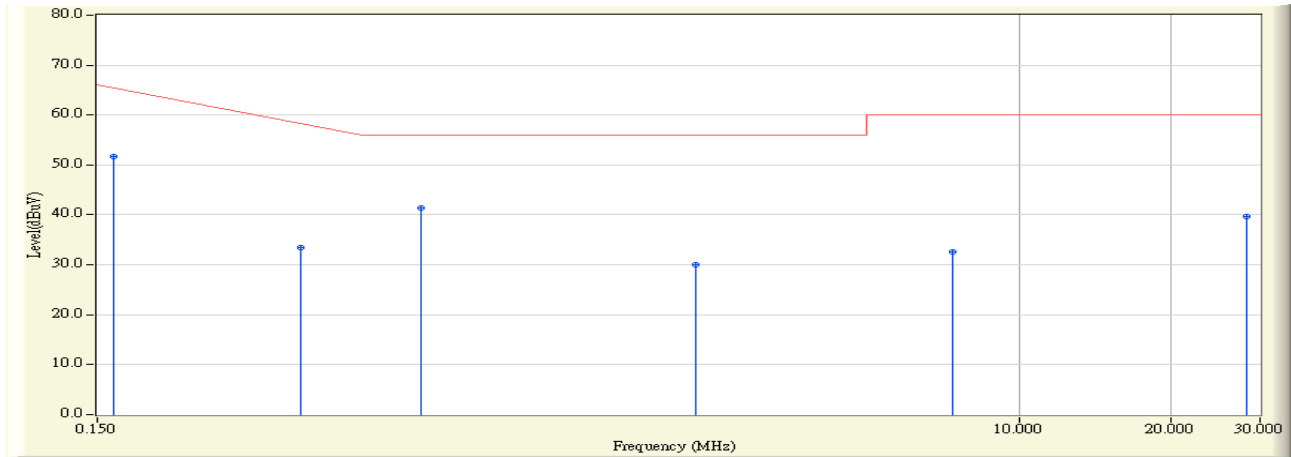

		Frequency (MHz)	Correct Factor (dB)	Reading Level (dBuV)	Measure Level (dBuV)	Margin (dB)	Limit (dBuV)	Detector Type
1	*	0.162	-0.030	51.670	51.640	-14.017	65.657	QUASPEAK
2		0.379	0.010	33.470	33.480	-25.977	59.457	QUASPEAK
3		0.654	0.040	41.340	41.380	-14.620	56.000	QUASPEAK
4		2.287	0.140	29.960	30.100	-25.900	56.000	QUASPEAK
5		7.387	0.370	32.220	32.590	-27.410	60.000	QUASPEAK
6		28.259	1.000	38.740	39.740	-20.260	60.000	QUASPEAK

Note:

1. All Reading Levels are Quasi-Peak and average value.
2. " * ", means this data is the worst emission level.
3. Measurement Level = Reading Level + Correct Factor.

Site : ShieldingRoom3	Time : 2008/06/26 - 16:09
Limit : CISPR_B_00M_AV	Margin : 0
Probe : SR3_LISN(16A) - Line1	Power : AC 120V/60Hz
EUT : WIRELESS G ADSL2+ MODEM ROUTER	Note : Mode 3: Transmit (D-Link) -G

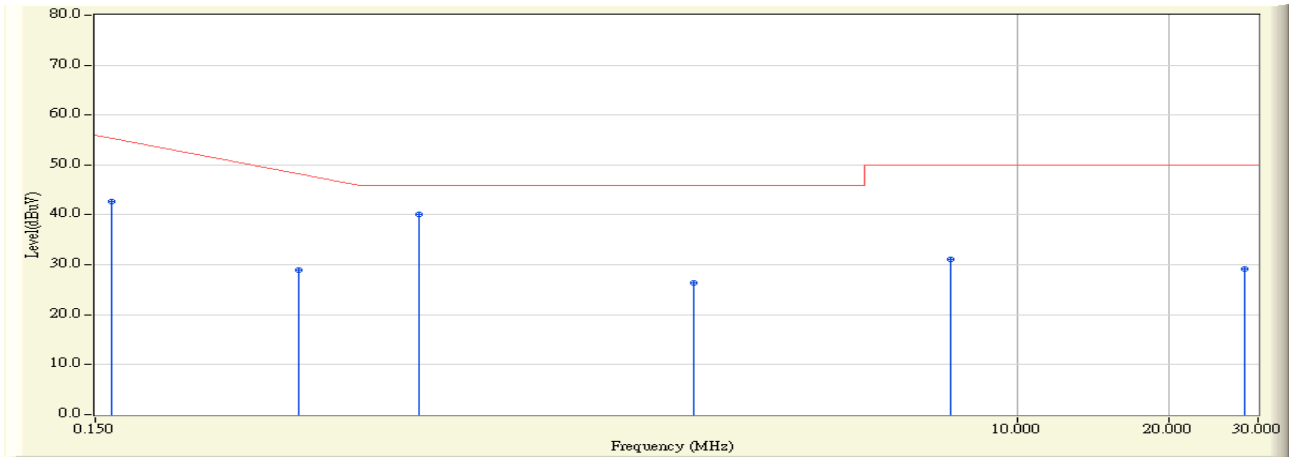

	Frequency (MHz)	Correct Factor (dB)	Reading Level (dBuV)	Measure Level (dBuV)	Margin (dB)	Limit (dBuV)	Detector Type
1	0.162	-0.030	42.810	42.780	-12.877	55.657	AVERAGE
2	0.379	0.010	28.860	28.870	-20.587	49.457	AVERAGE
3	* 0.654	0.040	39.990	40.030	-5.970	46.000	AVERAGE
4	2.287	0.140	26.310	26.450	-19.550	46.000	AVERAGE
5	7.387	0.370	30.660	31.030	-18.970	50.000	AVERAGE
6	28.259	1.000	28.090	29.090	-20.910	50.000	AVERAGE

Note:

1. All Reading Levels are Quasi-Peak and average value.
2. " * ", means this data is the worst emission level.
3. Measurement Level = Reading Level + Correct Factor.

Site : ShieldingRoom3	Time : 2008/06/26 - 16:14
Limit : CISPR_B_00M_QP	Margin : 0
Probe : SR3_LISN(16A) - Line2	Power : AC 120V/60Hz
EUT : WIRELESS G ADSL2+ MODEM ROUTER	Note : Mode 3: Transmit (D-Link) -G

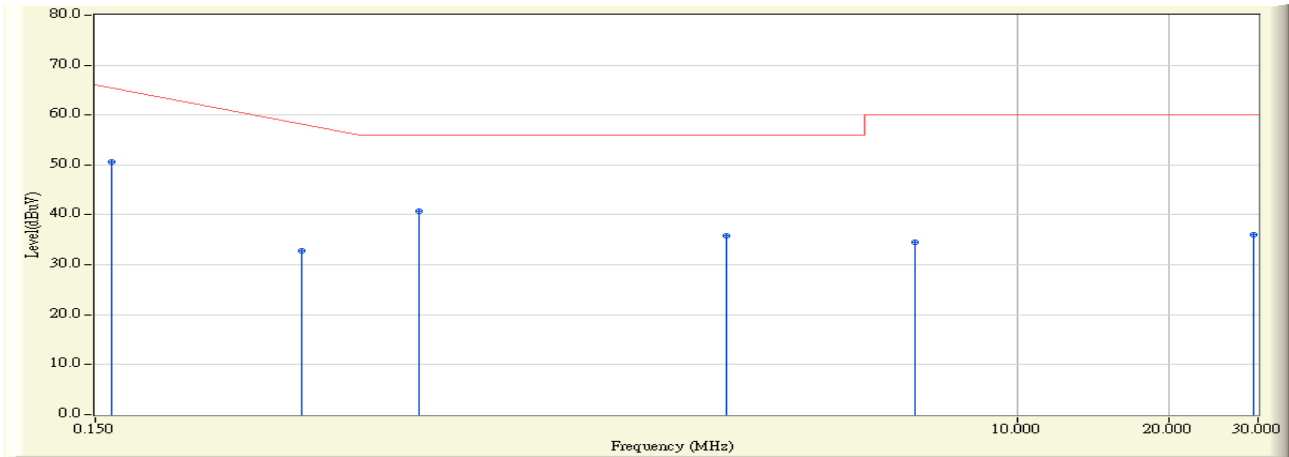

		Frequency (MHz)	Correct Factor (dB)	Reading Level (dBuV)	Measure Level (dBuV)	Margin (dB)	Limit (dBuV)	Detector Type
1	*	0.162	-0.030	50.690	50.660	-14.997	65.657	QUASPEAK
2		0.385	0.020	32.760	32.780	-26.506	59.286	QUASPEAK
3		0.654	0.050	40.620	40.670	-15.330	56.000	QUASPEAK
4		2.670	0.190	35.670	35.860	-20.140	56.000	QUASPEAK
5		6.270	0.360	34.150	34.510	-25.490	60.000	QUASPEAK
6		29.462	1.060	34.980	36.040	-23.960	60.000	QUASPEAK

Note:

1. All Reading Levels are Quasi-Peak and average value.
2. " * ", means this data is the worst emission level.
3. Measurement Level = Reading Level + Correct Factor.

Site : ShieldingRoom3	Time : 2008/06/26 - 16:14
Limit : CISPR_B_00M_AV	Margin : 0
Probe : SR3_LISN(16A) - Line2	Power : AC 120V/60Hz
EUT : WIRELESS G ADSL2+ MODEM ROUTER	Note : Mode 3: Transmit (D-Link) -G

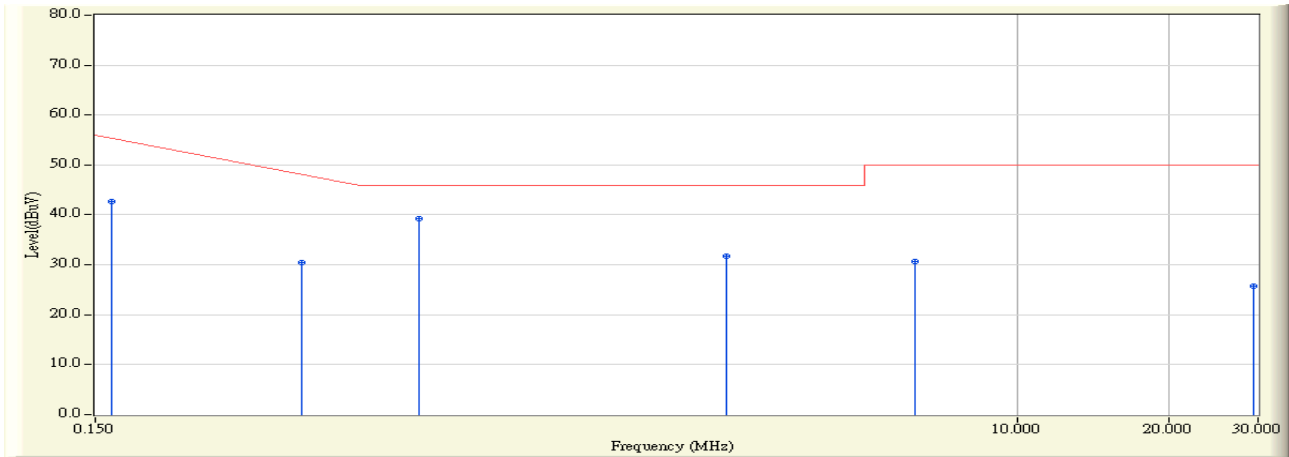

	Frequency (MHz)	Correct Factor (dB)	Reading Level (dBuV)	Measure Level (dBuV)	Margin (dB)	Limit (dBuV)	Detector Type
1	0.162	-0.030	42.670	42.640	-13.017	55.657	AVERAGE
2	0.385	0.020	30.410	30.430	-18.856	49.286	AVERAGE
3	* 0.654	0.050	39.130	39.180	-6.820	46.000	AVERAGE
4	2.670	0.190	31.500	31.690	-14.310	46.000	AVERAGE
5	6.270	0.360	30.330	30.690	-19.310	50.000	AVERAGE
6	29.462	1.060	24.660	25.720	-24.280	50.000	AVERAGE

Note:

1. All Reading Levels are Quasi-Peak and average value.
2. " * ", means this data is the worst emission level.
3. Measurement Level = Reading Level + Correct Factor.

Site : ShieldingRoom3	Time : 2008/06/26 - 16:20
Limit : CISPR_B_00M_QP	Margin : 0
Probe : SR3_LISN(16A) - Line1	Power : AC 120V/60Hz
EUT : WIRELESS G ADSL2+ MODEM ROUTER	Note : Mode 3: Transmit (D-Link) -N-20M

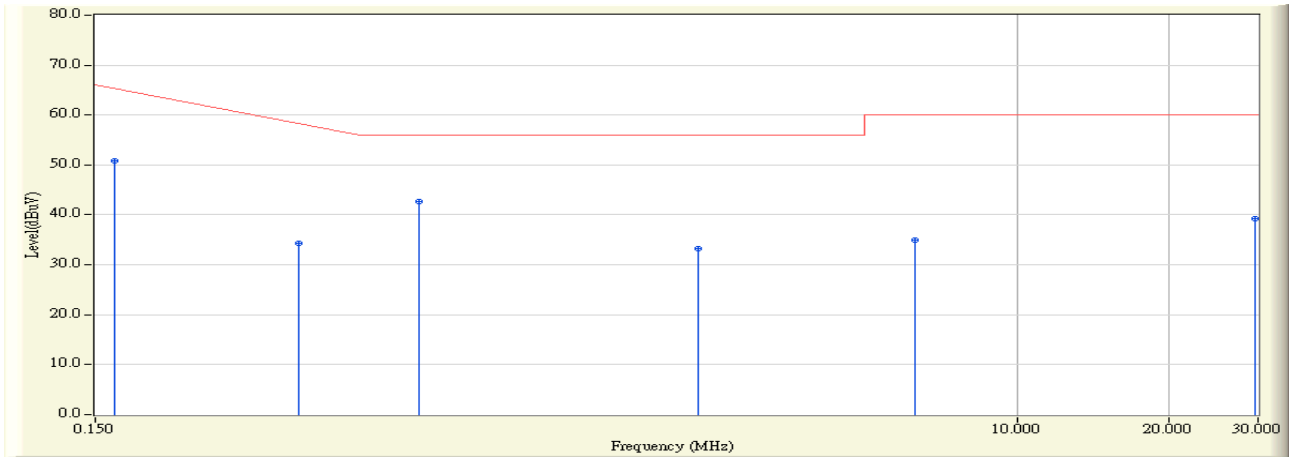

	Frequency (MHz)	Correct Factor (dB)	Reading Level (dBuV)	Measure Level (dBuV)	Margin (dB)	Limit (dBuV)	Detector Type
1	0.164	-0.030	50.870	50.840	-14.760	65.600	QUASPEAK
2	0.380	0.010	34.220	34.230	-25.199	59.429	QUASPEAK
3	*	0.040	42.680	42.720	-13.280	56.000	QUASPEAK
4	2.342	0.140	33.100	33.240	-22.760	56.000	QUASPEAK
5	6.265	0.320	34.570	34.890	-25.110	60.000	QUASPEAK
6	29.697	1.010	38.140	39.150	-20.850	60.000	QUASPEAK

Note:

1. All Reading Levels are Quasi-Peak and average value.
2. " * ", means this data is the worst emission level.
3. Measurement Level = Reading Level + Correct Factor.

Site : ShieldingRoom3	Time : 2008/06/26 - 16:20
Limit : CISPR_B_00M_AV	Margin : 0
Probe : SR3_LISN(16A) - Line1	Power : AC 120V/60Hz
EUT : WIRELESS G ADSL2+ MODEM ROUTER	Note : Mode 3: Transmit (D-Link) -N-20M

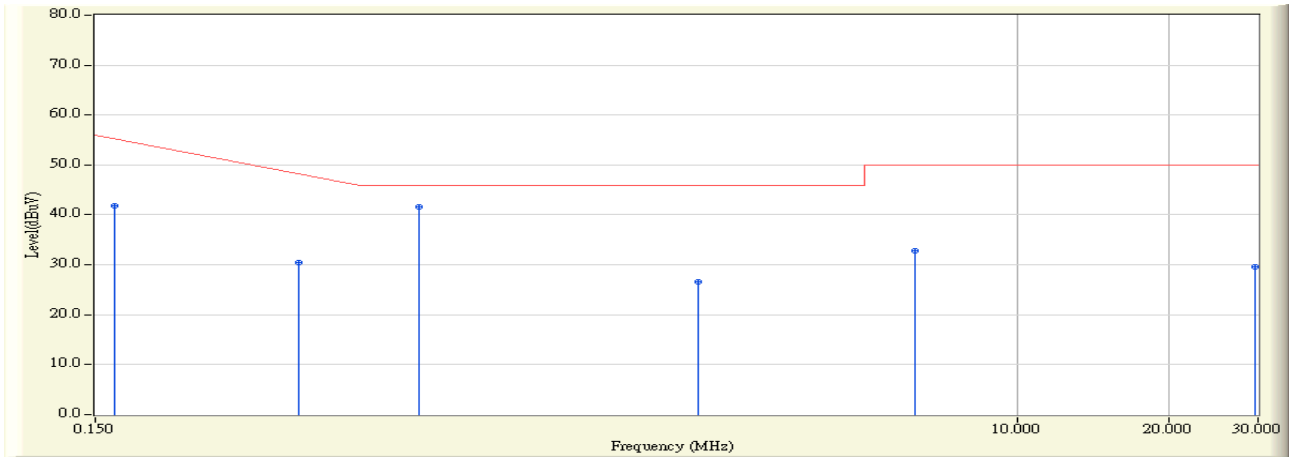

	Frequency (MHz)	Correct Factor (dB)	Reading Level (dBuV)	Measure Level (dBuV)	Margin (dB)	Limit (dBuV)	Detector Type
1	0.164	-0.030	41.880	41.850	-13.750	55.600	AVERAGE
2	0.380	0.010	30.480	30.490	-18.939	49.429	AVERAGE
3	* 0.654	0.040	41.540	41.580	-4.420	46.000	AVERAGE
4	2.342	0.140	26.370	26.510	-19.490	46.000	AVERAGE
5	6.265	0.320	32.390	32.710	-17.290	50.000	AVERAGE
6	29.697	1.010	28.650	29.660	-20.340	50.000	AVERAGE

Note:

1. All Reading Levels are Quasi-Peak and average value.
2. " * ", means this data is the worst emission level.
3. Measurement Level = Reading Level + Correct Factor.

Site : ShieldingRoom3	Time : 2008/06/26 - 16:28
Limit : CISPR_B_00M_QP	Margin : 0
Probe : SR3_LISN(16A) - Line2	Power : AC 120V/60Hz
EUT : WIRELESS G ADSL2+ MODEM ROUTER	Note : Mode 3: Transmit (D-Link) -N-20M

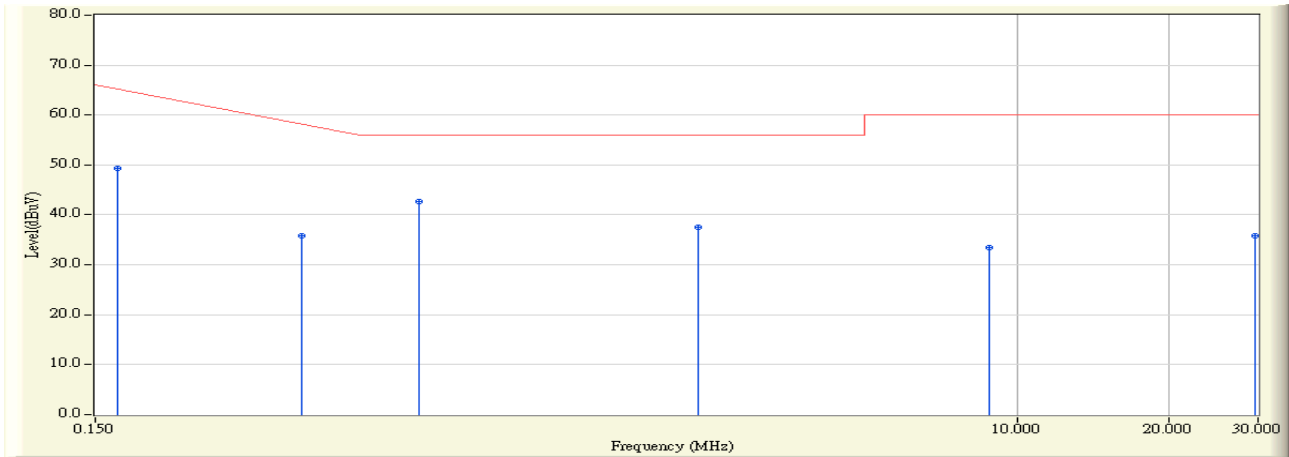

	Frequency (MHz)	Correct Factor (dB)	Reading Level (dBuV)	Measure Level (dBuV)	Margin (dB)	Limit (dBuV)	Detector Type
1	0.166	-0.030	49.290	49.260	-16.283	65.543	QUASIPeAK
2	0.383	0.020	35.780	35.800	-23.543	59.343	QUASIPeAK
3	*	0.050	42.640	42.690	-13.310	56.000	QUASIPeAK
4	2.345	0.180	37.410	37.590	-18.410	56.000	QUASIPeAK
5	8.833	0.480	32.930	33.410	-26.590	60.000	QUASIPeAK
6	29.591	1.070	34.740	35.810	-24.190	60.000	QUASIPeAK

Note:

1. All Reading Levels are Quasi-Peak and average value.
2. " * ", means this data is the worst emission level.
3. Measurement Level = Reading Level + Correct Factor.

Site : ShieldingRoom3	Time : 2008/06/26 - 16:28
Limit : CISPR_B_00M_AV	Margin : 0
Probe : SR3_LISN(16A) - Line2	Power : AC 120V/60Hz
EUT : WIRELESS G ADSL2+ MODEM ROUTER	Note : Mode 3: Transmit (D-Link) -N-20M

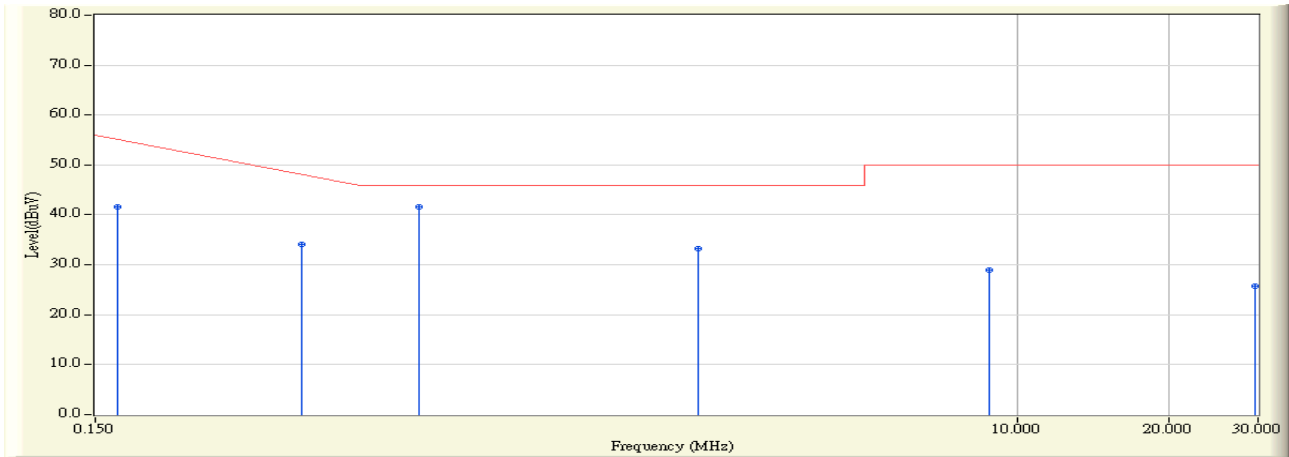

	Frequency (MHz)	Correct Factor (dB)	Reading Level (dBuV)	Measure Level (dBuV)	Margin (dB)	Limit (dBuV)	Detector Type
1	0.166	-0.030	41.580	41.550	-13.993	55.543	AVERAGE
2	0.383	0.020	34.050	34.070	-15.273	49.343	AVERAGE
3	* 0.654	0.050	41.540	41.590	-4.410	46.000	AVERAGE
4	2.345	0.180	32.990	33.170	-12.830	46.000	AVERAGE
5	8.833	0.480	28.440	28.920	-21.080	50.000	AVERAGE
6	29.591	1.070	24.620	25.690	-24.310	50.000	AVERAGE

Note:

1. All Reading Levels are Quasi-Peak and average value.
2. " * ", means this data is the worst emission level.
3. Measurement Level = Reading Level + Correct Factor.

Site : ShieldingRoom3	Time : 2008/06/26 - 16:32
Limit : CISPR_B_00M_QP	Margin : 0
Probe : SR3_LISN(16A) - Line1	Power : AC 120V/60Hz
EUT : WIRELESS G ADSL2+ MODEM ROUTER	Note : Mode 3: Transmit (D-Link) -N-40M

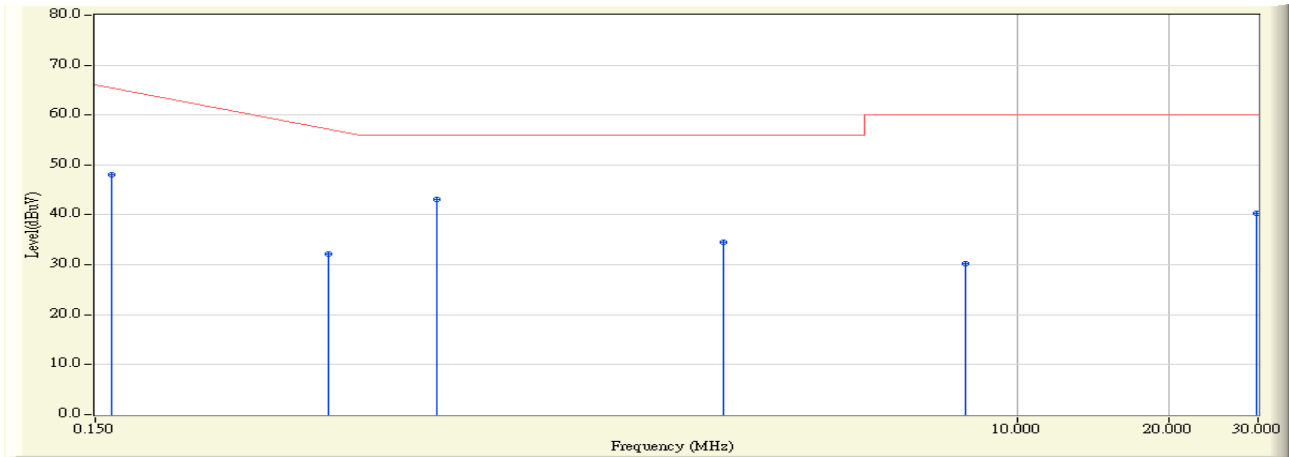

	Frequency (MHz)	Correct Factor (dB)	Reading Level (dBuV)	Measure Level (dBuV)	Margin (dB)	Limit (dBuV)	Detector Type
1	0.162	-0.030	48.100	48.070	-17.587	65.657	QUASPEAK
2	0.434	0.020	32.230	32.250	-25.636	57.886	QUASPEAK
3	* 0.709	0.040	43.090	43.130	-12.870	56.000	QUASPEAK
4	2.618	0.150	34.420	34.570	-21.430	56.000	QUASPEAK
5	7.913	0.390	29.860	30.250	-29.750	60.000	QUASPEAK
6	29.724	1.010	39.360	40.370	-19.630	60.000	QUASPEAK

Note:

1. All Reading Levels are Quasi-Peak and average value.
2. " * ", means this data is the worst emission level.
3. Measurement Level = Reading Level + Correct Factor.

Site : ShieldingRoom3	Time : 2008/06/26 - 16:32
Limit : CISPR_B_00M_AV	Margin : 0
Probe : SR3_LISN(16A) - Line1	Power : AC 120V/60Hz
EUT : WIRELESS G ADSL2+ MODEM ROUTER	Note : Mode 3: Transmit (D-Link) -N-40M

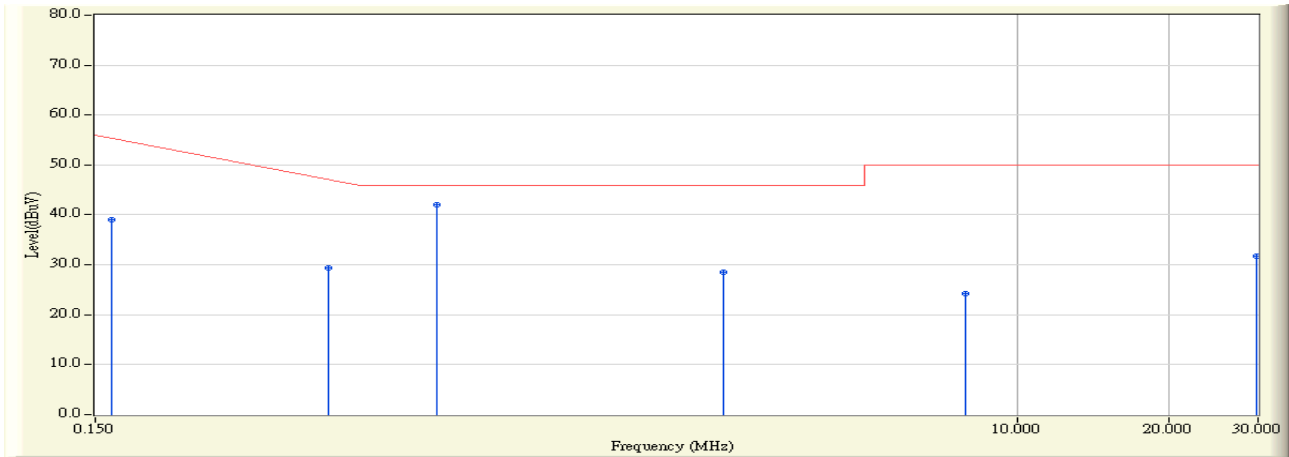

	Frequency (MHz)	Correct Factor (dB)	Reading Level (dBuV)	Measure Level (dBuV)	Margin (dB)	Limit (dBuV)	Detector Type
1	0.162	-0.030	39.030	39.000	-16.657	55.657	AVERAGE
2	0.434	0.020	29.310	29.330	-18.556	47.886	AVERAGE
3	* 0.709	0.040	42.000	42.040	-3.960	46.000	AVERAGE
4	2.618	0.150	28.340	28.490	-17.510	46.000	AVERAGE
5	7.913	0.390	23.760	24.150	-25.850	50.000	AVERAGE
6	29.724	1.010	30.710	31.720	-18.280	50.000	AVERAGE

Note:

1. All Reading Levels are Quasi-Peak and average value.
2. " * ", means this data is the worst emission level.
3. Measurement Level = Reading Level + Correct Factor.

Site : ShieldingRoom3	Time : 2008/06/26 - 16:38
Limit : CISPR_B_00M_QP	Margin : 0
Probe : SR3_LISN(16A) - Line2	Power : AC 120V/60Hz
EUT : WIRELESS G ADSL2+ MODEM ROUTER	Note : Mode 3: Transmit (D-Link) -N-40M

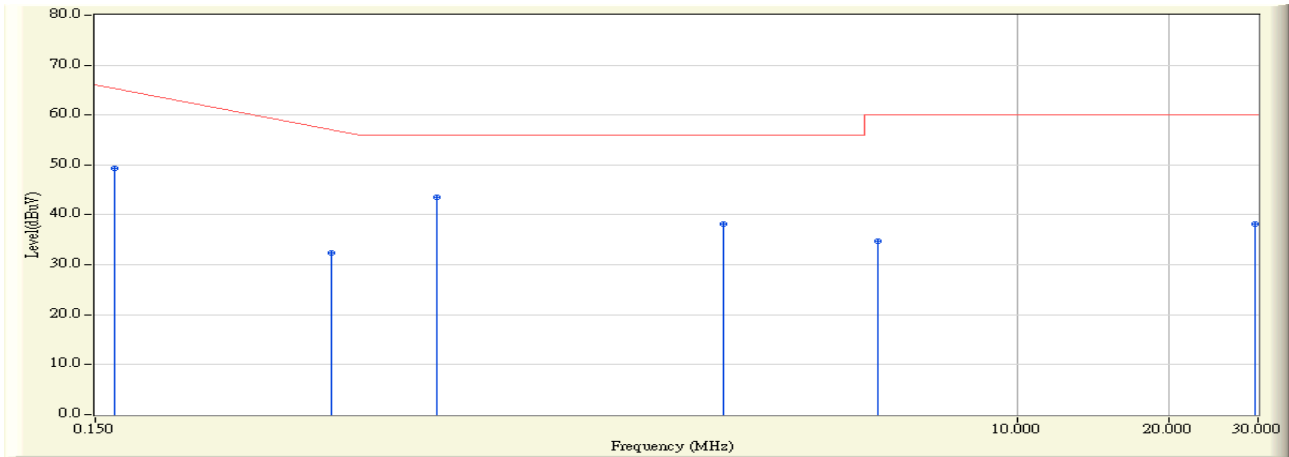

	Frequency (MHz)	Correct Factor (dB)	Reading Level (dBuV)	Measure Level (dBuV)	Margin (dB)	Limit (dBuV)	Detector Type
1	0.164	-0.030	49.370	49.340	-16.260	65.600	QUASPEAK
2	0.440	0.030	32.290	32.320	-25.394	57.714	QUASPEAK
3	* 0.709	0.053	43.460	43.513	-12.487	56.000	QUASPEAK
4	2.619	0.190	38.020	38.210	-17.790	56.000	QUASPEAK
5	5.292	0.311	34.400	34.711	-25.289	60.000	QUASPEAK
6	29.564	1.070	37.090	38.160	-21.840	60.000	QUASPEAK

Note:

1. All Reading Levels are Quasi-Peak and average value.
2. " * ", means this data is the worst emission level.
3. Measurement Level = Reading Level + Correct Factor.

Site : ShieldingRoom3	Time : 2008/06/26 - 16:38
Limit : CISPR_B_00M_AV	Margin : 0
Probe : SR3_LISN(16A) - Line2	Power : AC 120V/60Hz
EUT : WIRELESS G ADSL2+ MODEM ROUTER	Note : Mode 3: Transmit (D-Link) -N-40M

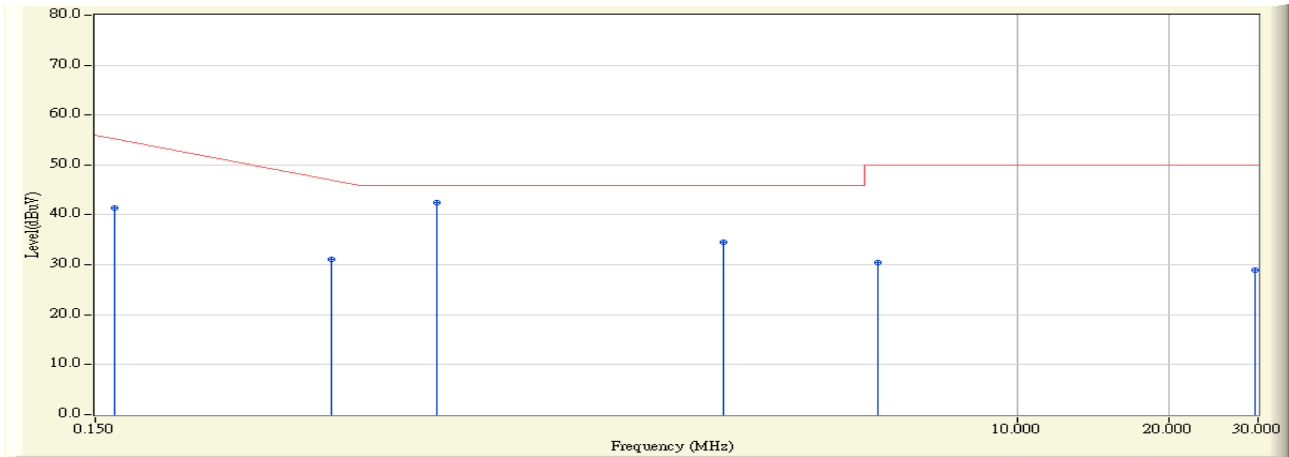

	Frequency (MHz)	Correct Factor (dB)	Reading Level (dBuV)	Measure Level (dBuV)	Margin (dB)	Limit (dBuV)	Detector Type
1	0.164	-0.030	41.420	41.390	-14.210	55.600	AVERAGE
2	0.440	0.030	30.990	31.020	-16.694	47.714	AVERAGE
3	* 0.709	0.053	42.510	42.563	-3.437	46.000	AVERAGE
4	2.619	0.190	34.240	34.430	-11.570	46.000	AVERAGE
5	5.292	0.311	30.190	30.501	-19.499	50.000	AVERAGE
6	29.564	1.070	27.960	29.030	-20.970	50.000	AVERAGE

Note:

1. All Reading Levels are Quasi-Peak and average value.
2. " * ", means this data is the worst emission level.
3. Measurement Level = Reading Level + Correct Factor.

3. Peak Power Output

3.1. Test Equipment

The following test equipments are used during the radiated emission tests:

Item	Equipment	Manufacturer	Model No. / Serial No.	Last Cal.
1	Spectrum Analyzer	R & S	FSP / 100561	Jan., 2008
2	No.1 OATS			Sep., 2007

Note: 1. All equipments are calibrated with traceable calibrations. Each calibration is traceable to the national or international standards.

3.2. Test Setup

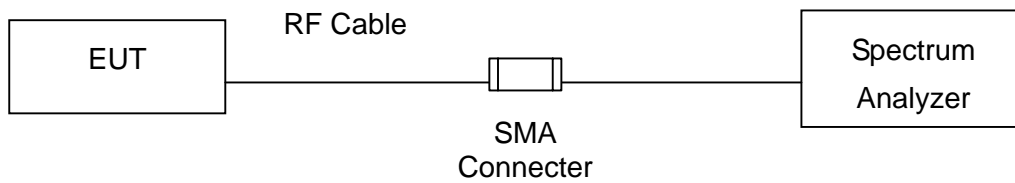

3.3. Limits

According to RSS-210 Issue 7, Annex 8 (June 2007), The maximum peak power shall be less 1 Watt..

3.4. Uncertainty

The measurement uncertainty is defined as ± 1.27 dB

3.5. Test Result

Product	WIRELESS G ADSL2+ MODEM ROUTER		
Test Item	Peak Power Output		
Test Mode	Transmit		
Date of Test	2008/06/30	Test Site	No.1 OATS

IEEE 802.11b				
Channel No.	Frequency (MHz)	Measure Level (dBm)	Limit (dBm)	Result
1	2412	18.58	1Watt= 30 dBm	Pass
6	2437	18.67	1Watt= 30 dBm	Pass
11	2462	18.45	1Watt= 30 dBm	Pass

Peak Power Output Value (dBm)						
Channel No.	Frequency (MHz)	Data Rate				Required Limit
		1 Mbps	2Mbps	5.5Mbps	11Mbps	
1	2412.00	--	--	--	18.58	1Watt= 30 dBm
6	2437.00	16.32	16.65	18.34	18.67	1Watt= 30 dBm
11	2462.00	--	--	--	18.45	1Watt= 30 dBm

Note: Measure Level =Reading value + cable loss

Channel 1

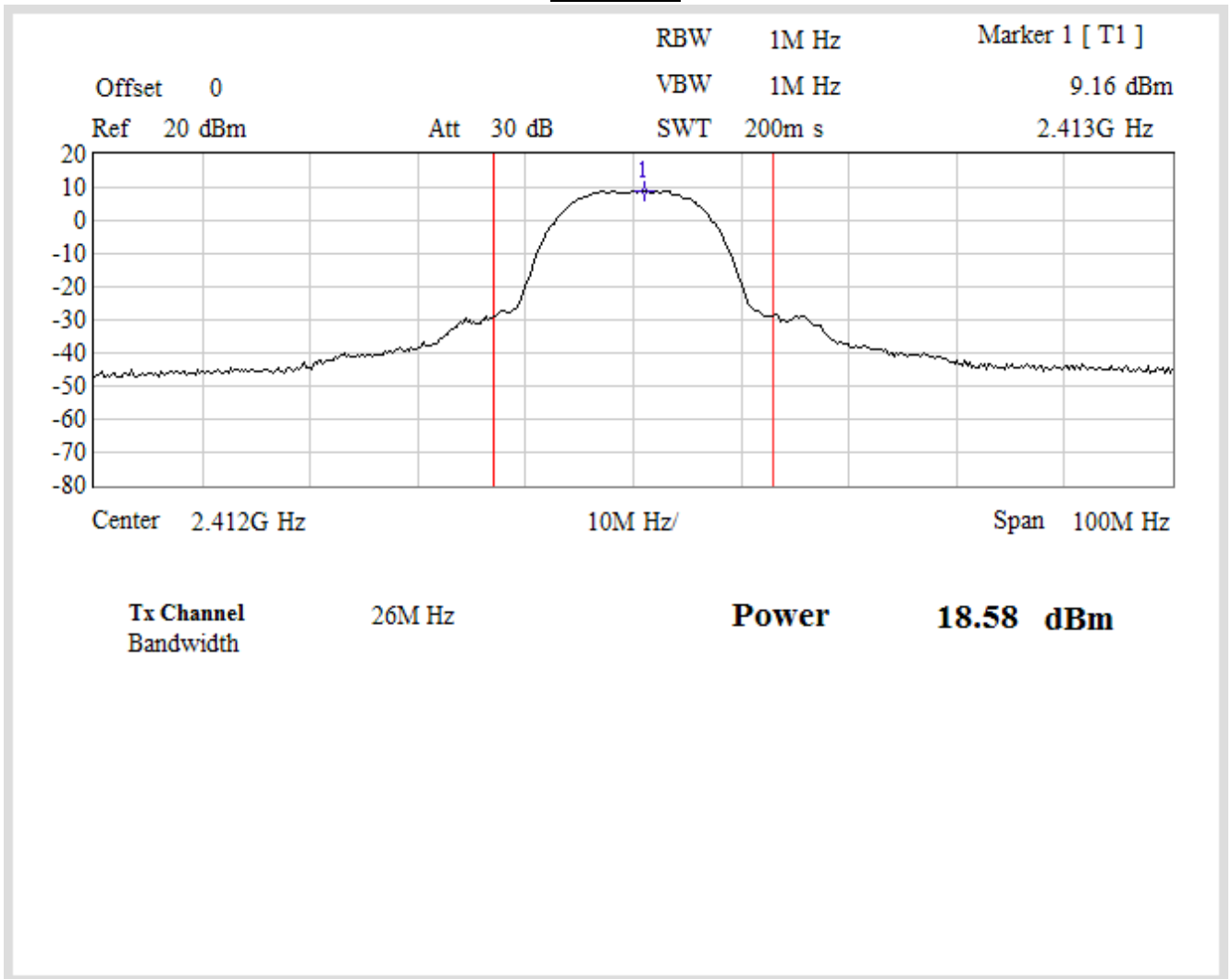

Channel 6

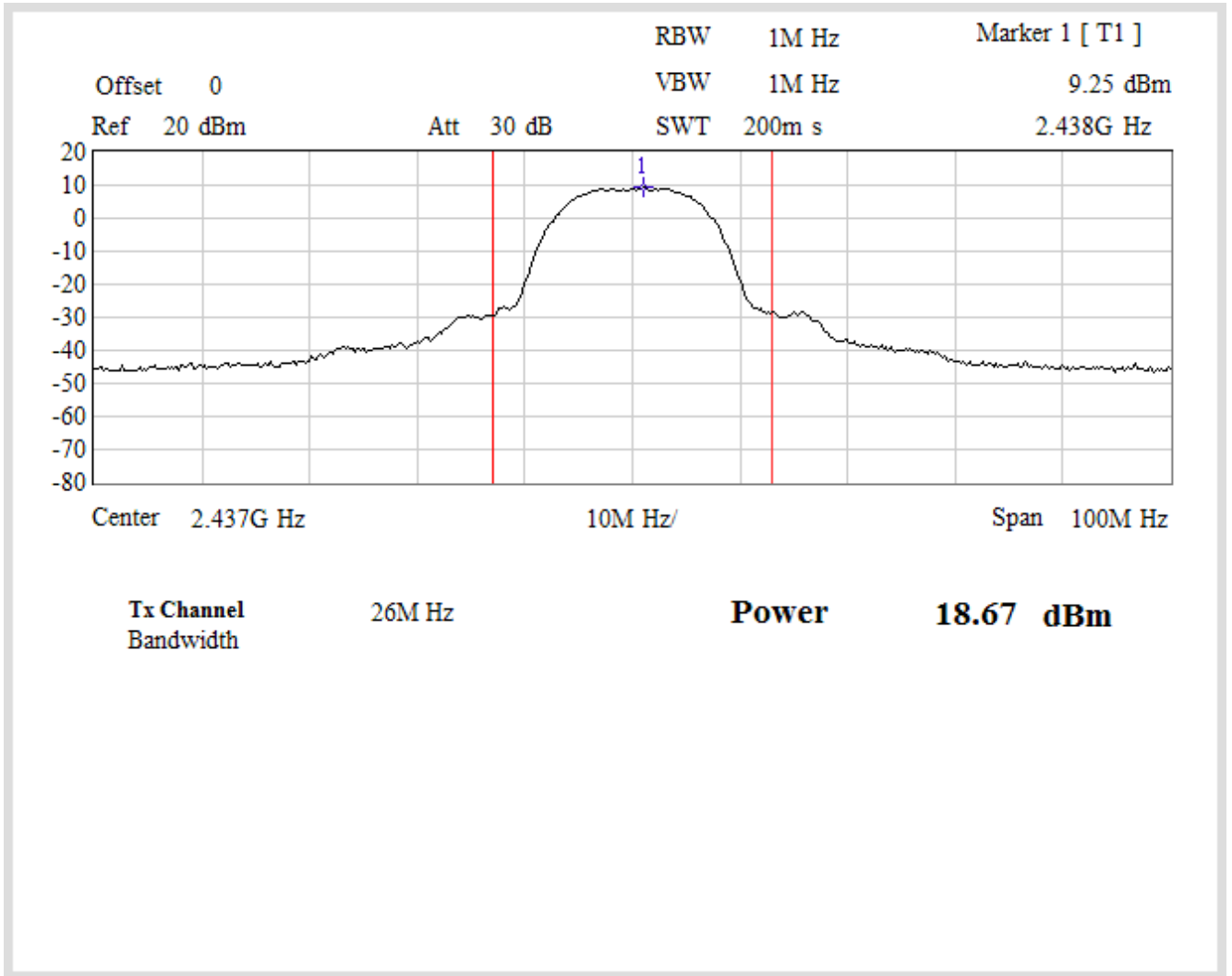

Channel 11

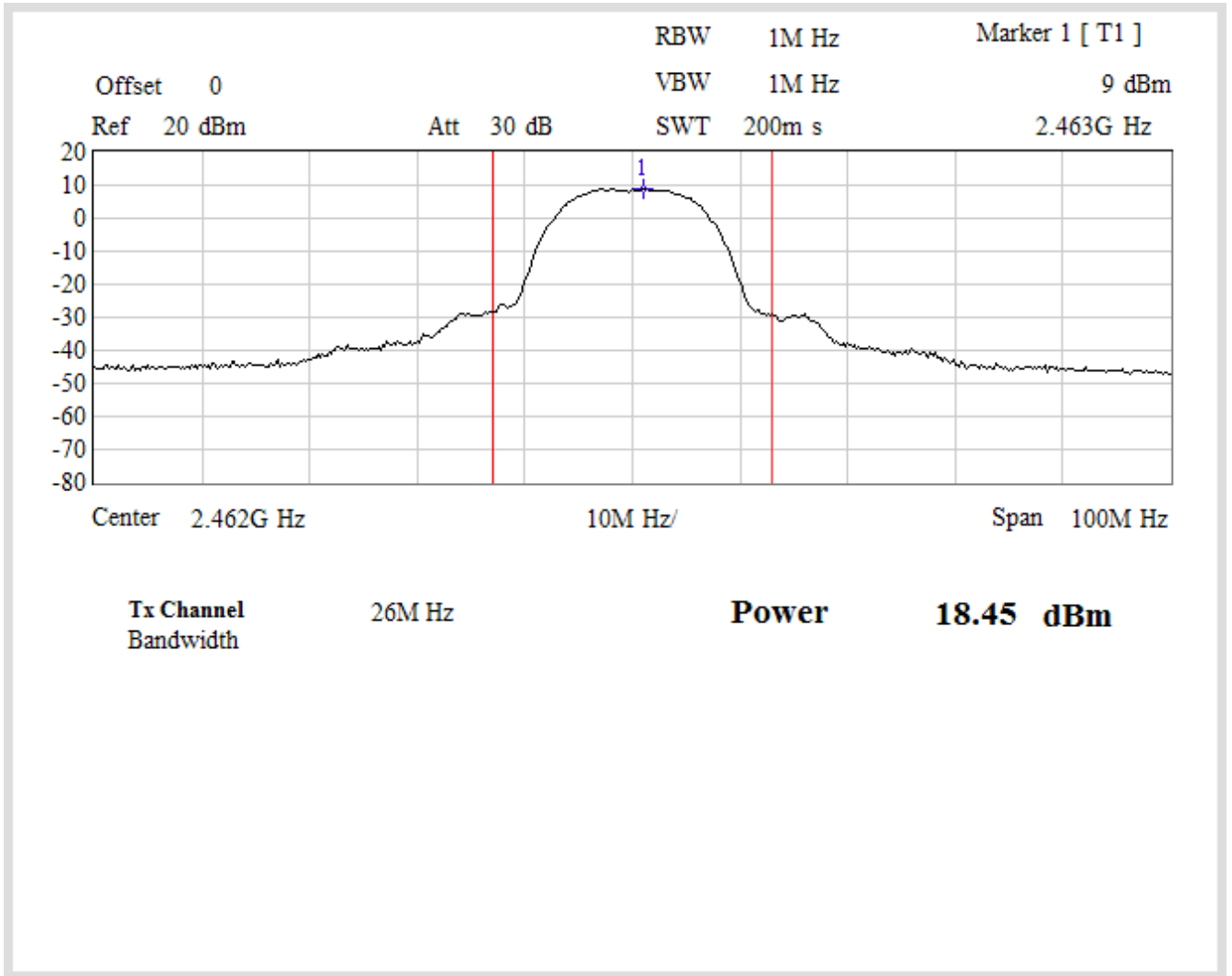

Product	WIRELESS G ADSL2+ MODEM ROUTER		
Test Item	Peak Power Output		
Test Mode	Transmit		
Date of Test	2008/06/30	Test Site	No.1 OATS

IEEE 802.11g				
Channel No.	Frequency (MHz)	Measure Level (dBm)	Limit (dBm)	Result
1	2412	19.17	1Watt= 30 dBm	Pass
6	2437	19.29	1Watt= 30 dBm	Pass
11	2462	19.13	1Watt= 30 dBm	Pass

Peak Power Output Value(dBm)										
Channel No.	Frequency (MHz)	Data Rate (Mbps)								Required Limit
		6 Mbps	9 Mbps	12 Mbps	18 Mbps	24 Mbps	36 Mbps	48 Mbps	54 Mbps	
1	2412.00	--	--	--	--	--	--	--	19.17	1Watt= 30 dBm
6	2437.00	19.12	19.15	19.18	19.20	19.22	19.25	19.27	19.29	1Watt= 30 dBm
11	2462.00	--	--	--	--	--	--	--	19.13	1Watt= 30 dBm

Note: Measure Level =Reading value + cable loss

Channel 1

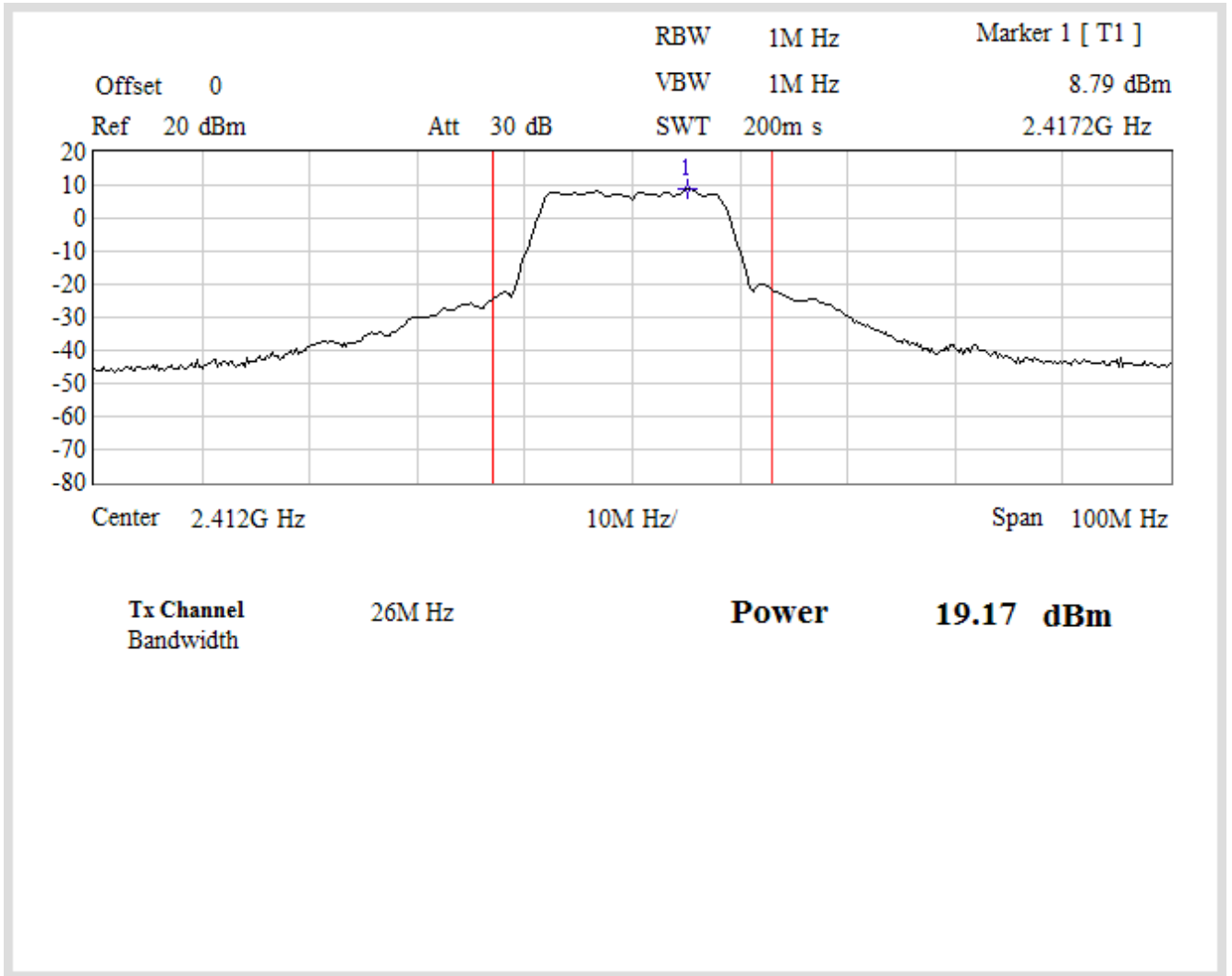

Channel 6

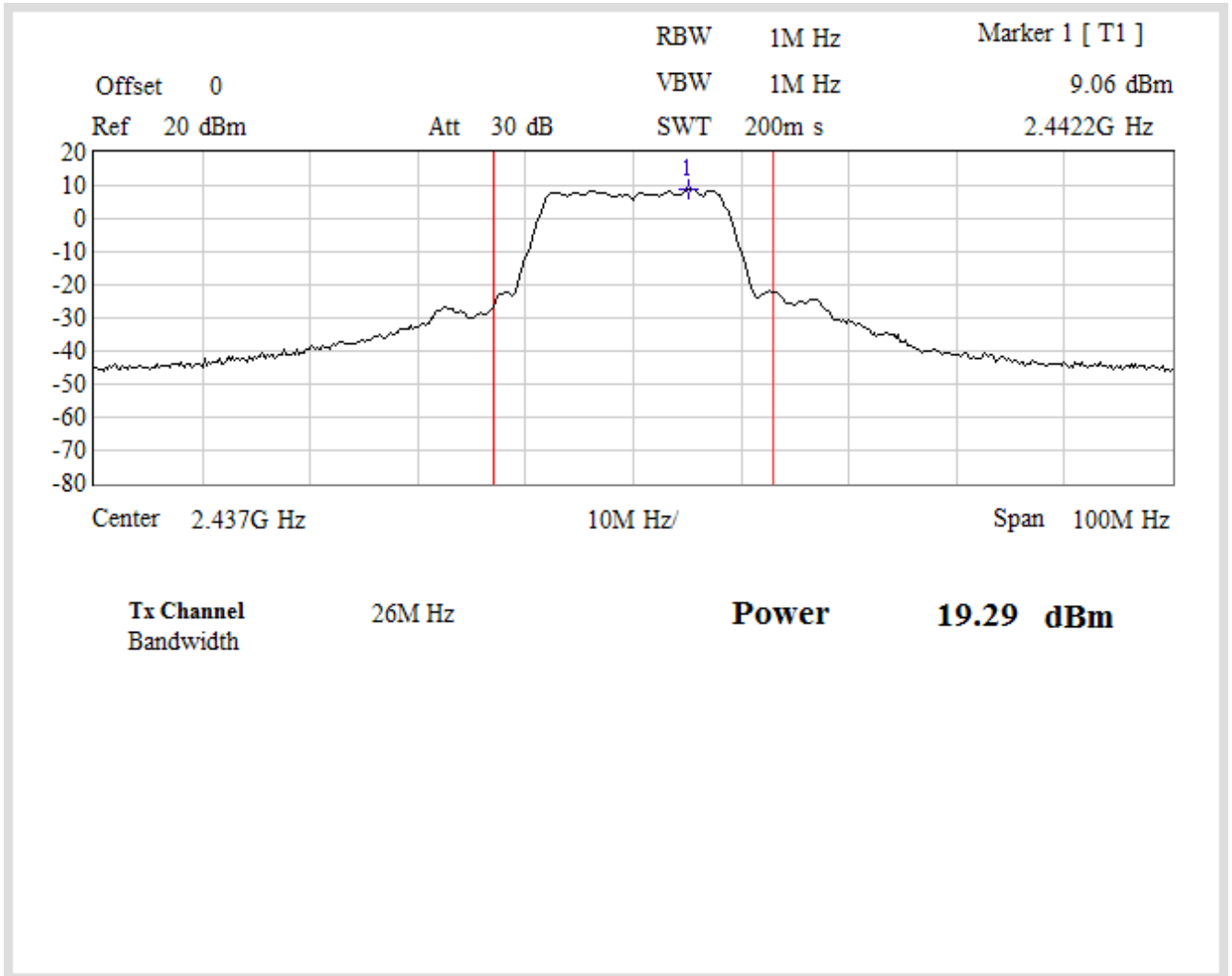

Channel 11

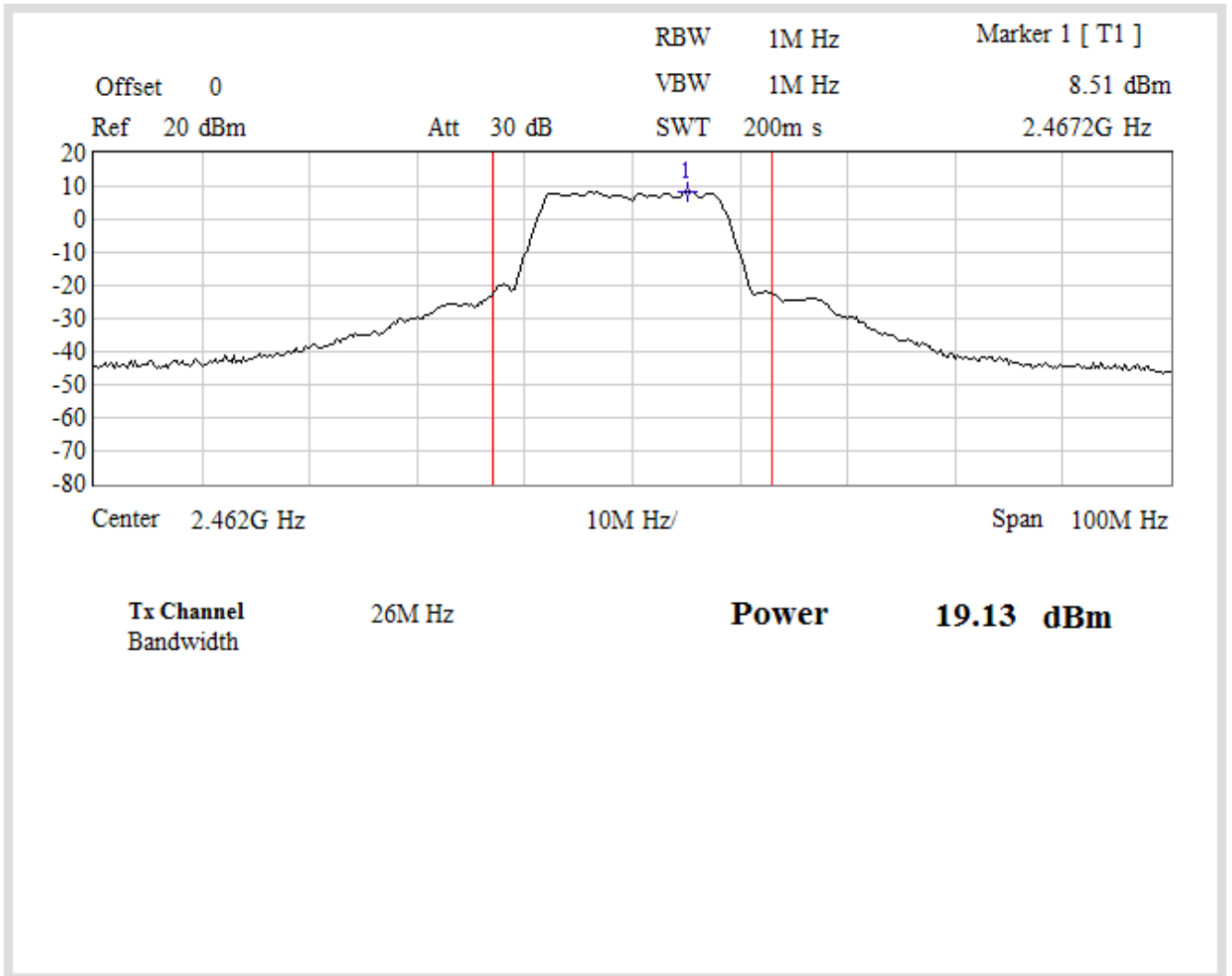

Product	WIRELESS G ADSL2+ MODEM ROUTER		
Test Item	Peak Power Output		
Test Mode	Transmit		
Date of Test	2008/06/30	Test Site	No.1 OATS

IEEE 802.11n (20M)

The worst emission of data rate is 130Mbps.

Peak Power Output (dBm)										
MCS Index		0	1	2	3	4	5	6	7	Required Limit
Channel No	Frequency (MHz)	Data Rate								
		6.5	13	19.5	26	39	52	58.5	65	
1	2412	--	--	--	--	--	--	--	--	30dBm
6	2437	19.59	19.62	19.63	19.65	19.67	19.70	19.72	20.73	30dBm
11	2462	--	--	--	--	--	--	--	--	30dBm

Peak Power Output (dBm)										
MCS Index		8	9	10	11	12	13	14	15	Required Limit
Channel No	Frequency (MHz)	Data Rate								
		13	26	39	52	78	104	117	130	
1	2412	--	--	--	--	--	--	--	20.91	30dBm
6	2437	20.75	20.77	20.79	20.81	20.83	20.86	20.88	20.91	30dBm
11	2462	--	--	--	--	--	--	--	21.14	30dBm

Product	WIRELESS G ADSL2+ MODEM ROUTER		
Test Item	Peak Power Output		
Test Mode	Transmit		
Date of Test	2008/06/30	Test Site	No.1 OATS

IEEE 802.11n (ANT A (20MHz))				
Channel No.	Frequency (MHz)	Measure Level (dBm)	Limit (dBm)	Result
1	2412	18.34	1Watt= 30 dBm	Pass
6	2437	18.02	1Watt= 30 dBm	Pass
11	2462	18.30	1Watt= 30 dBm	Pass

IEEE 802.11n (ANT B (20MHz))				
Channel No.	Frequency (MHz)	Measure Level (dBm)	Limit (dBm)	Result
1	2412	17.42	1Watt= 30 dBm	Pass
6	2437	17.77	1Watt= 30 dBm	Pass
11	2462	17.95	1Watt= 30 dBm	Pass

IEEE802.11n MCS15 20MHz; ANT: ANT A+ ANT B				
Channel No.	Frequency (MHz)	Measure Level (dBm)	Limit (dBm)	Result
1	2412	20.91	1Watt= 30 dBm	Pass
6	2437	20.91	1Watt= 30 dBm	Pass
11	2462	21.14	1Watt= 30 dBm	Pass

Note: Measure Level =Reading value + cable loss

Channel 1

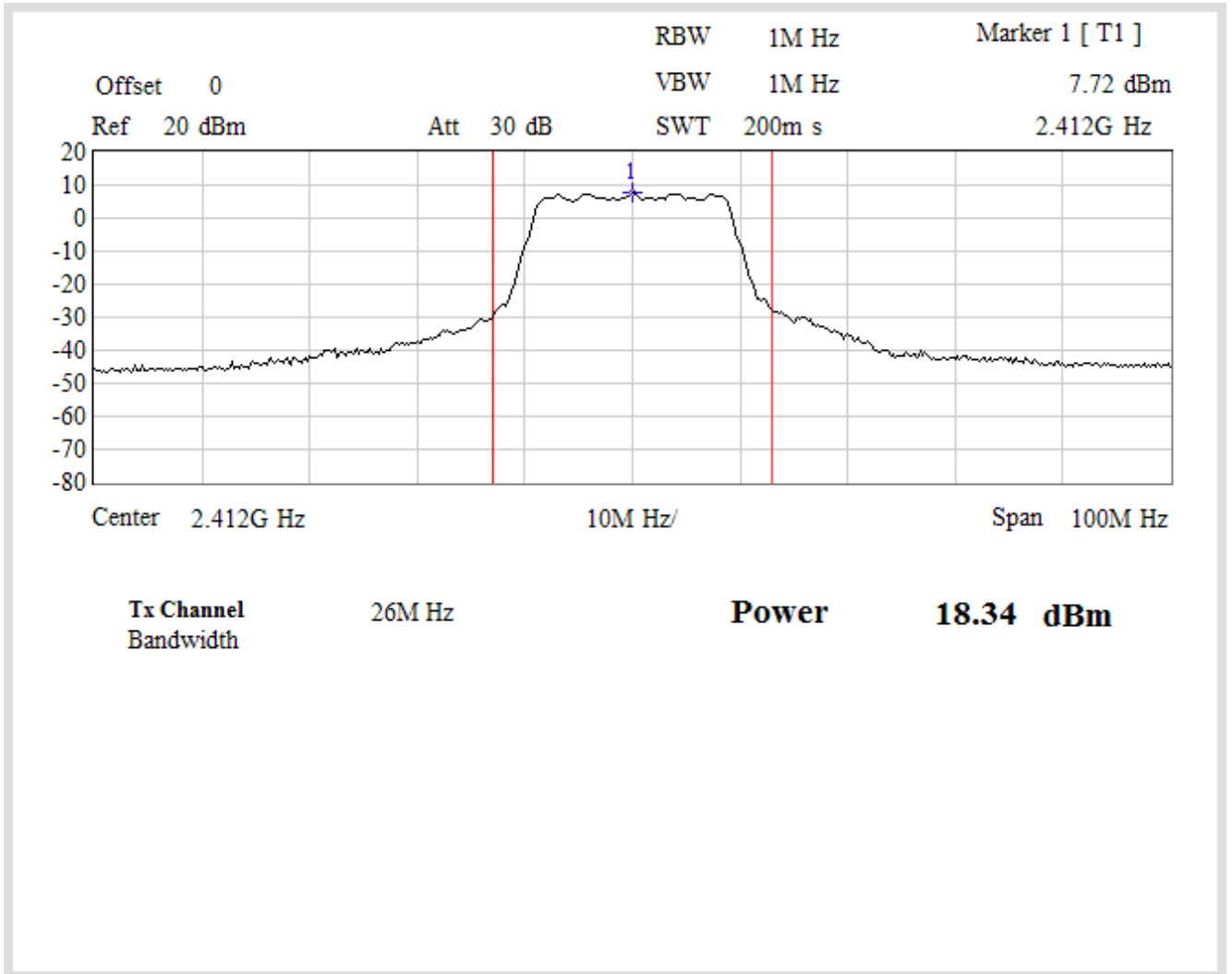

Channel 6

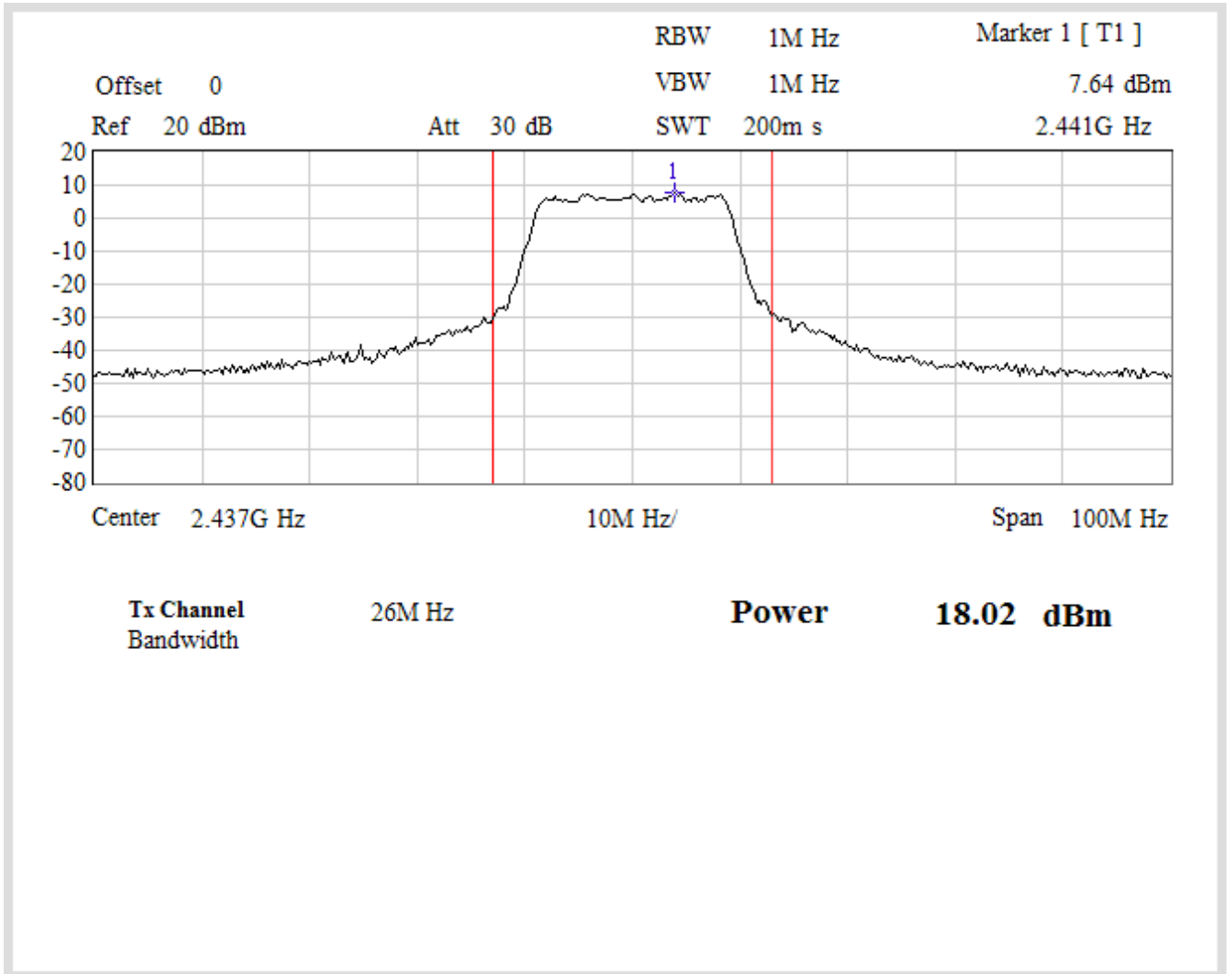

Channel 11

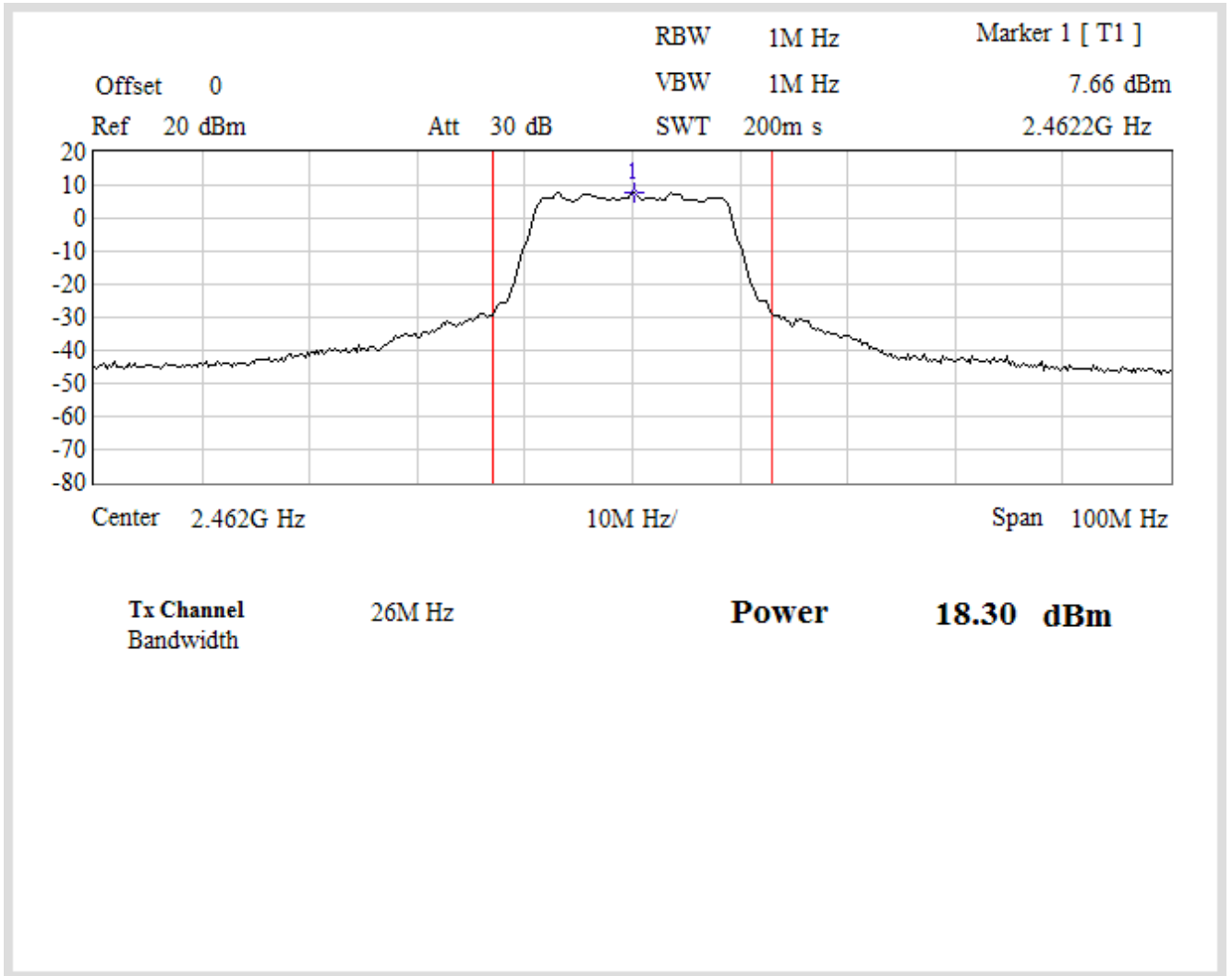

Channel 1

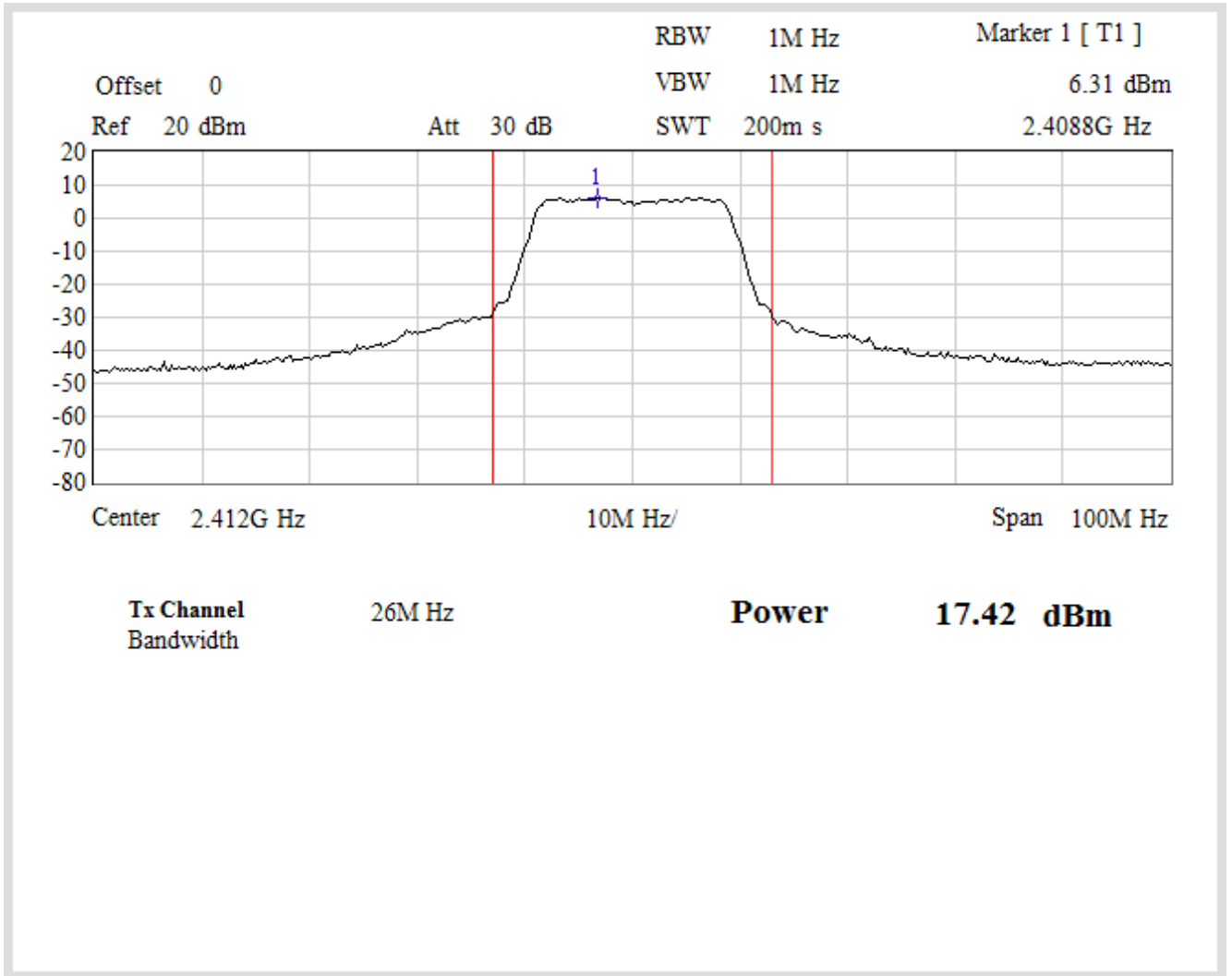

Channel 6

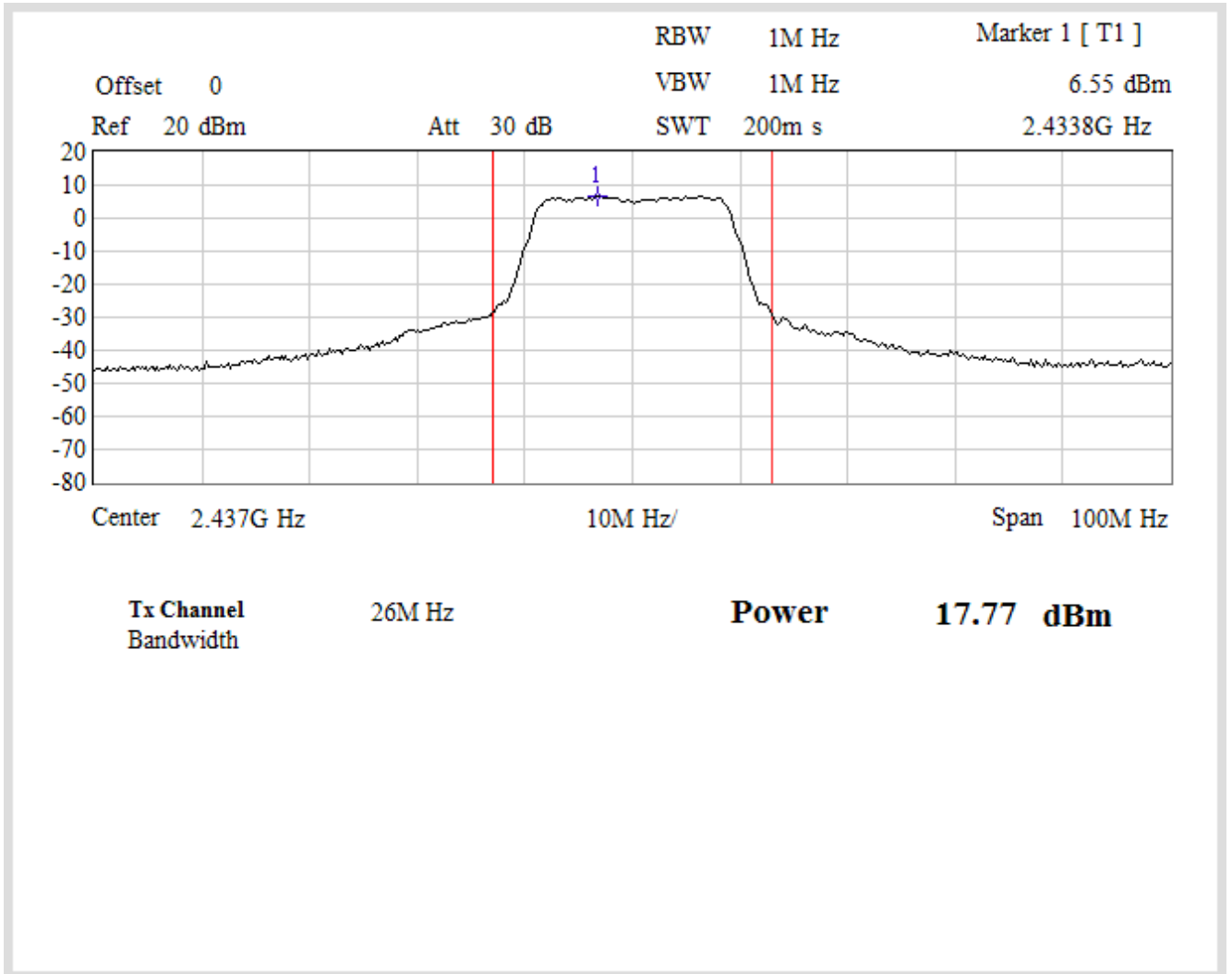

Channel 11

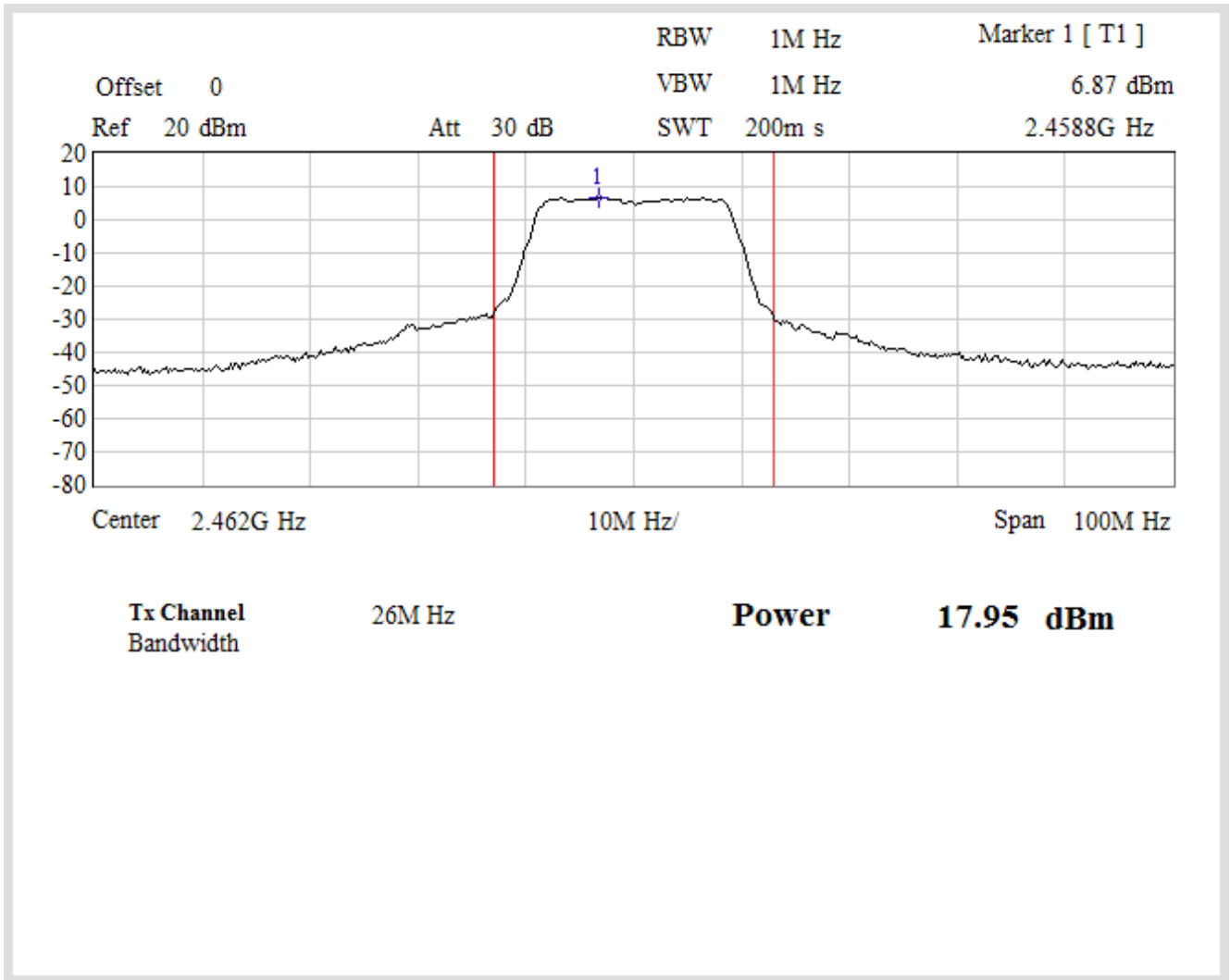

Product	WIRELESS G ADSL2+ MODEM ROUTER		
Test Item	Peak Power Output		
Test Mode	Transmit		
Date of Test	2008/06/30	Test Site	No.1 OATS

IEEE802.11n (40M)

The worst emission of data rate is 130Mbps

Peak Power Output (dBm)										
MCS Index		0	1	2	3	4	5	6	7	Required Limit
Channel No	Frequency (MHz)	Data Rate								
		6.5	13	19.5	26	39	52	58.5	65	
1	2412	--	--	--	--	--	--	--	--	30dBm
6	2437	19.38	19.39	19.41	19.43	19.44	19.47	19.49	19.5	30dBm
11	2462	--	--	--	--	--	--	--	--	30dBm

Peak Power Output (dBm)										
MCS Index		8	9	10	11	12	13	14	15	Required Limit
Channel No	Frequency (MHz)	Data Rate								
		13	26	39	52	78	104	117	130	
3	2412	--	--	--	--	--	--	--	19.43	30dBm
6	2437	19.52	19.53	19.56	19.58	19.60	19.62	19.63	19.65	30dBm
9	2462	--	--	--	--	--	--	--	19.87	30dBm

Product	WIRELESS G ADSL2+ MODEM ROUTER		
Test Item	Peak Power Output		
Test Mode	Transmit		
Date of Test	2008/06/30	Test Site	No.1 OATS

IEEE 802.11n (ANT A (40MHz))				
Channel No.	Frequency (MHz)	Measure Level (dBm)	Limit (dBm)	Result
3	2422	16.40	1Watt= 30 dBm	Pass
6	2437	16.56	1Watt= 30 dBm	Pass
9	2452	16.90	1Watt= 30 dBm	Pass

IEEE 802.11n (ANT B (40MHz))				
Channel No.	Frequency (MHz)	Measure Level (dBm)	Limit (dBm)	Result
3	2422	16.44	1Watt= 30 dBm	Pass
6	2437	16.72	1Watt= 30 dBm	Pass
9	2452	16.82	1Watt= 30 dBm	Pass

IEEE802.11n ;MCS15 40MHz; ANT: ANT A + ANT B				
Channel No.	Frequency (MHz)	Measure Level (dBm)	Limit (dBm)	Result
3	2422	19.43	1Watt= 30 dBm	Pass
6	2437	19.65	1Watt= 30 dBm	Pass
9	2452	19.87	1Watt= 30 dBm	Pass

Note: Measure Level =Reading value + cable loss

Channel 3

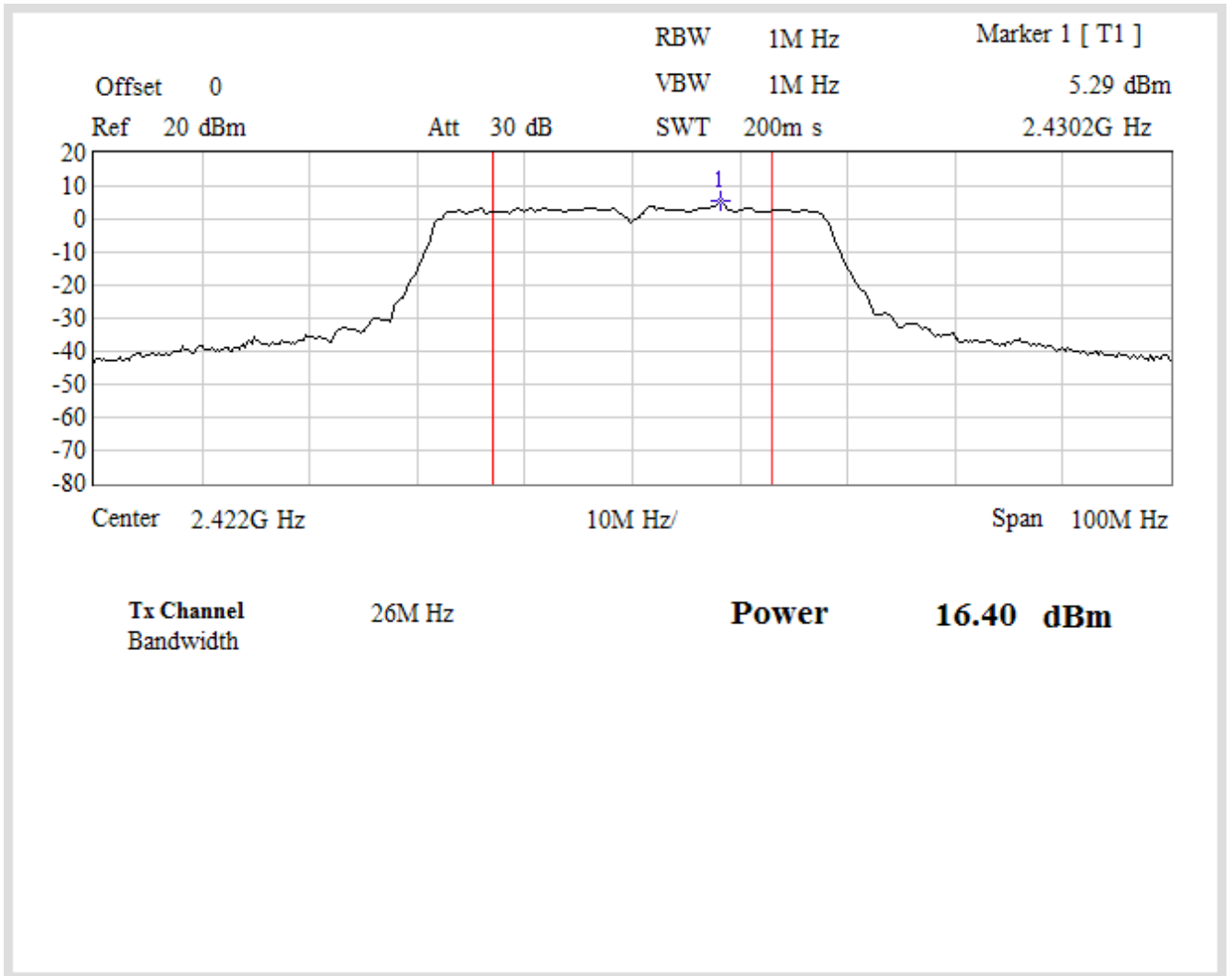

Channel 6

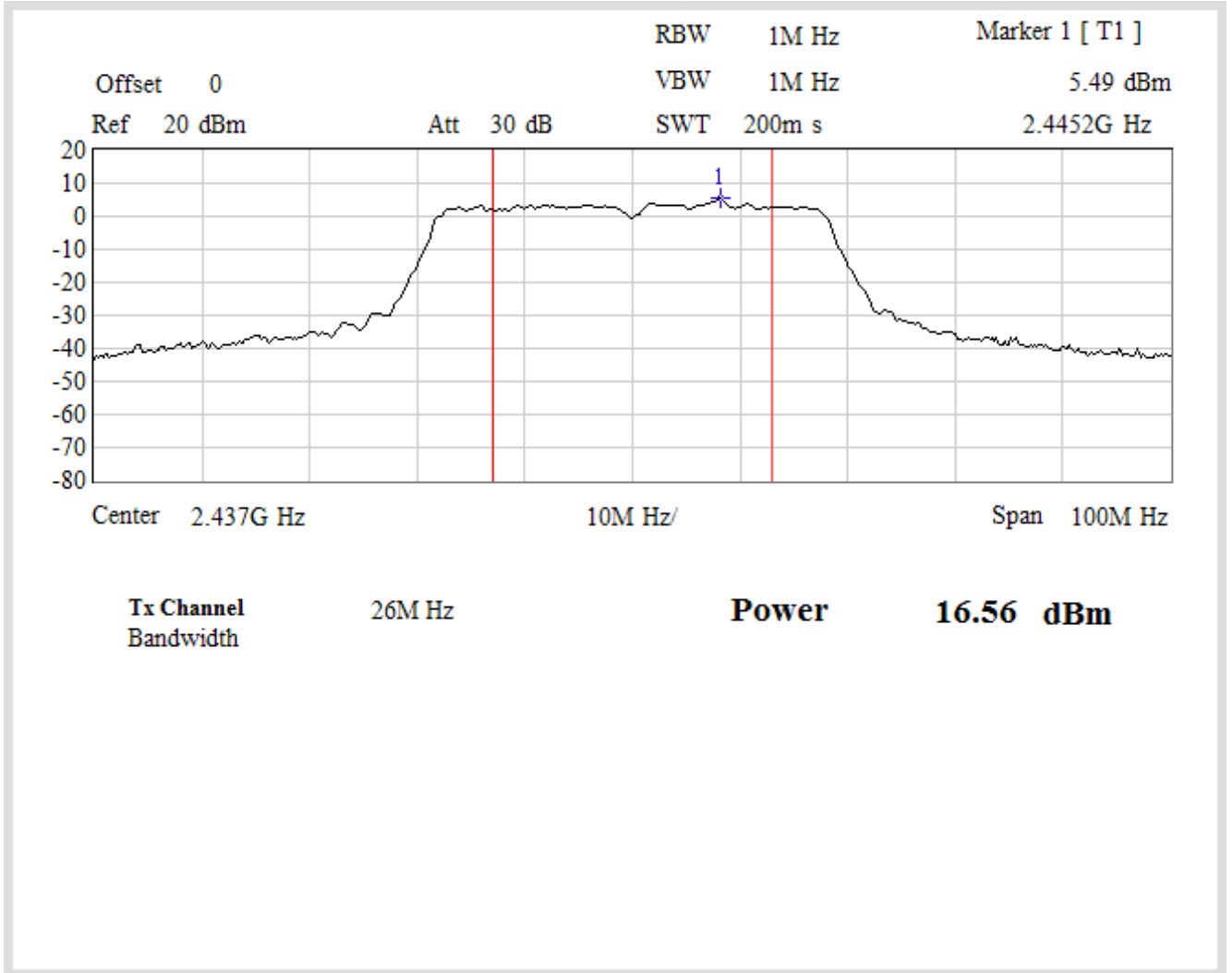

Channel 9

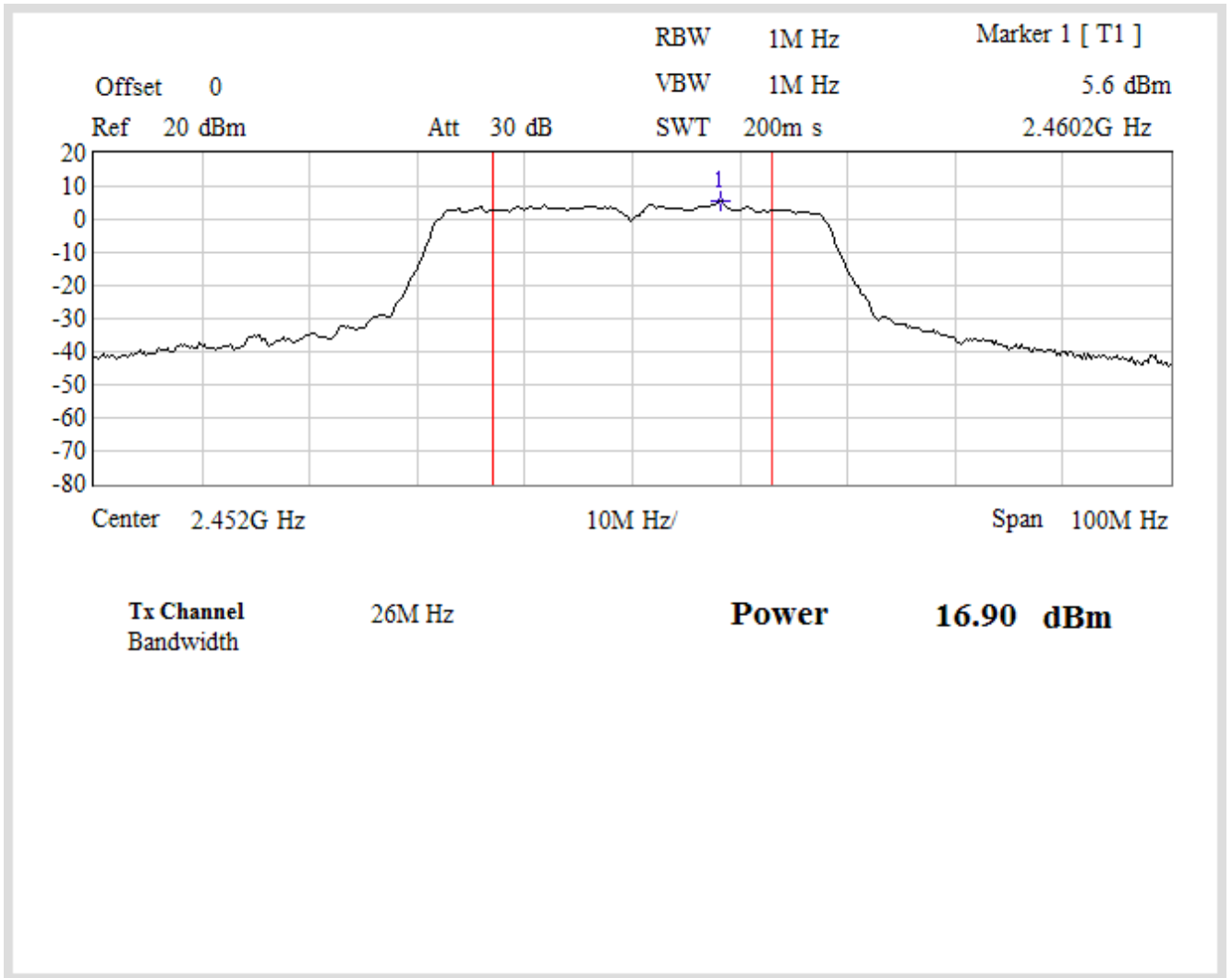

Channel 3

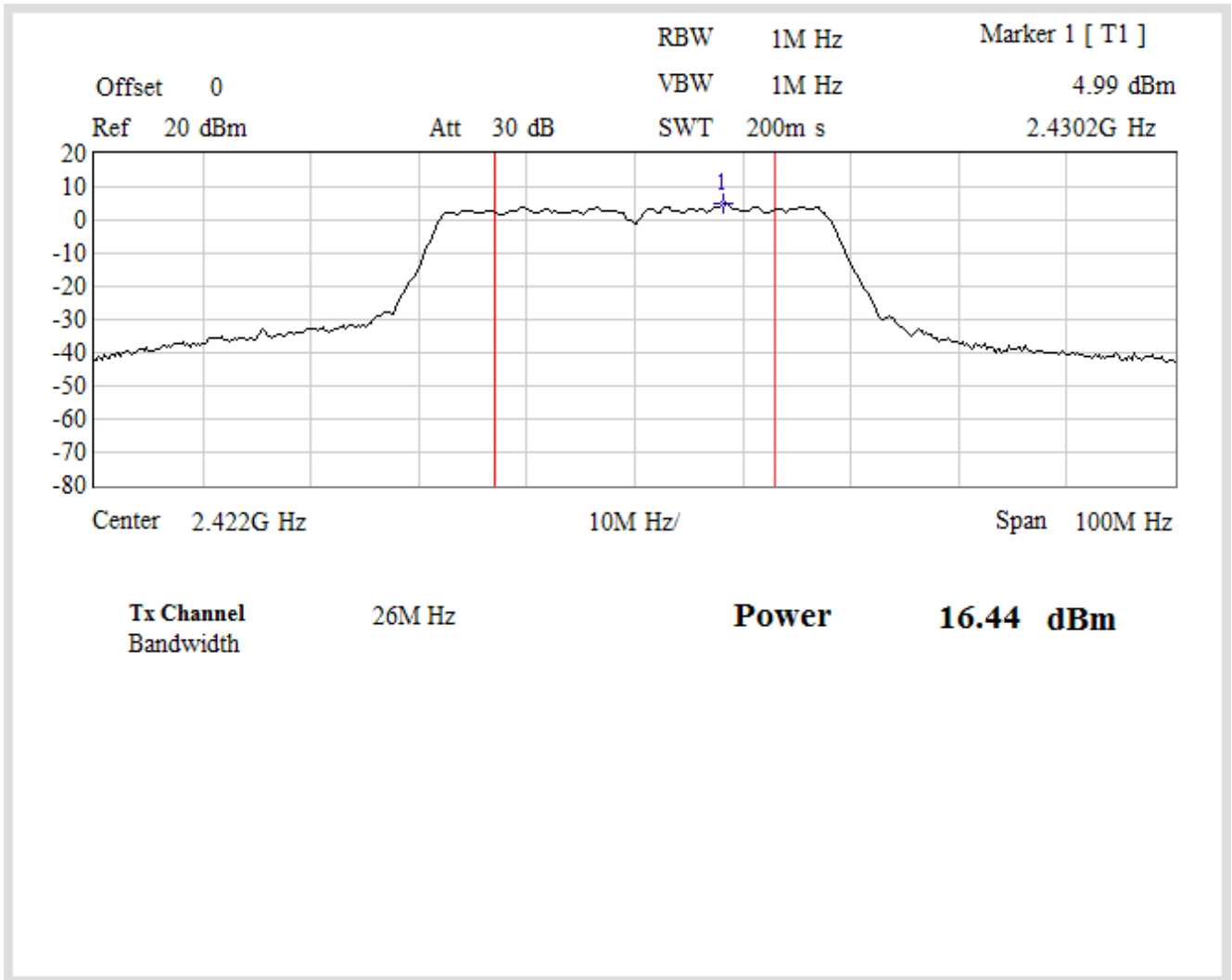

Channel 6

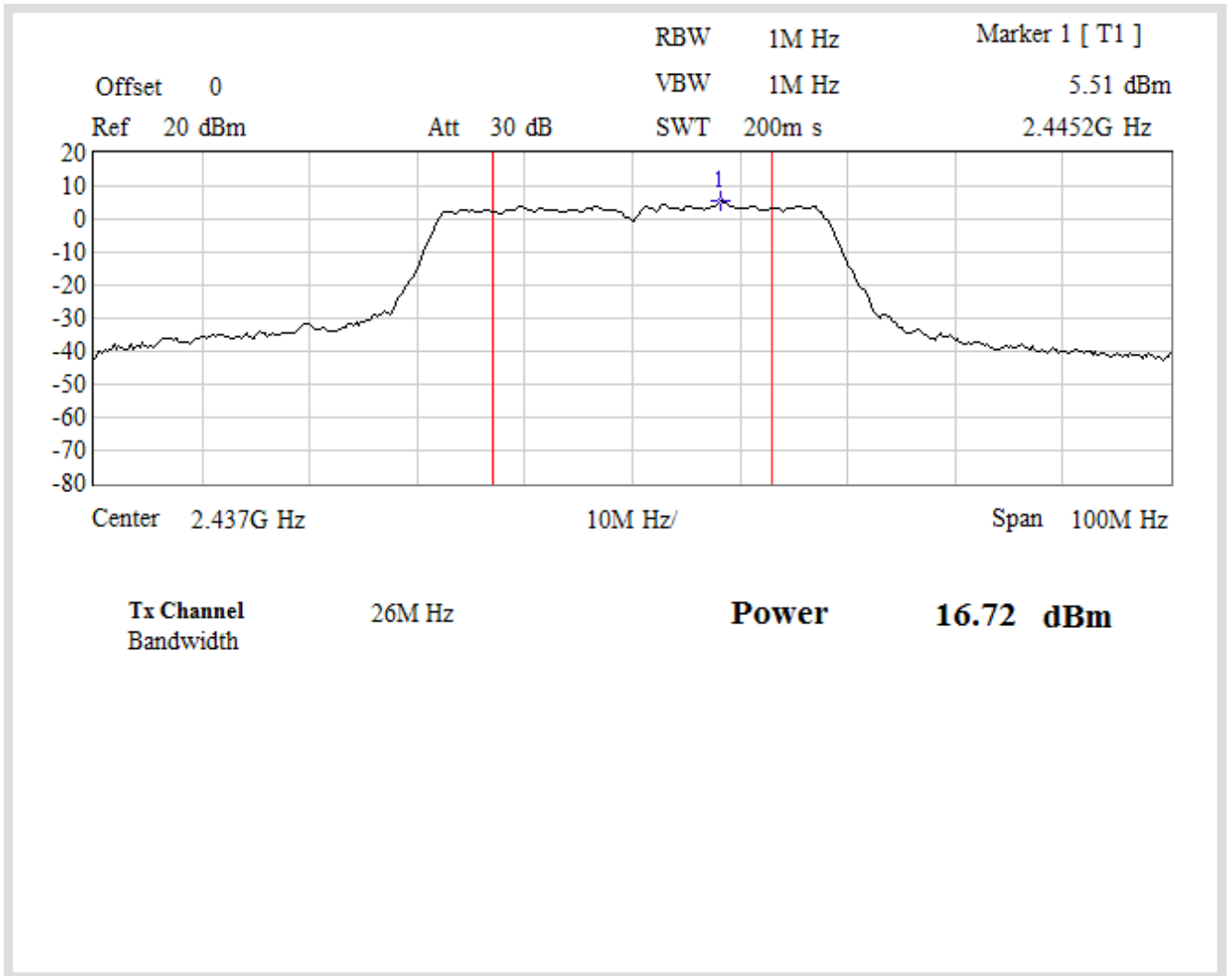

Channel 9

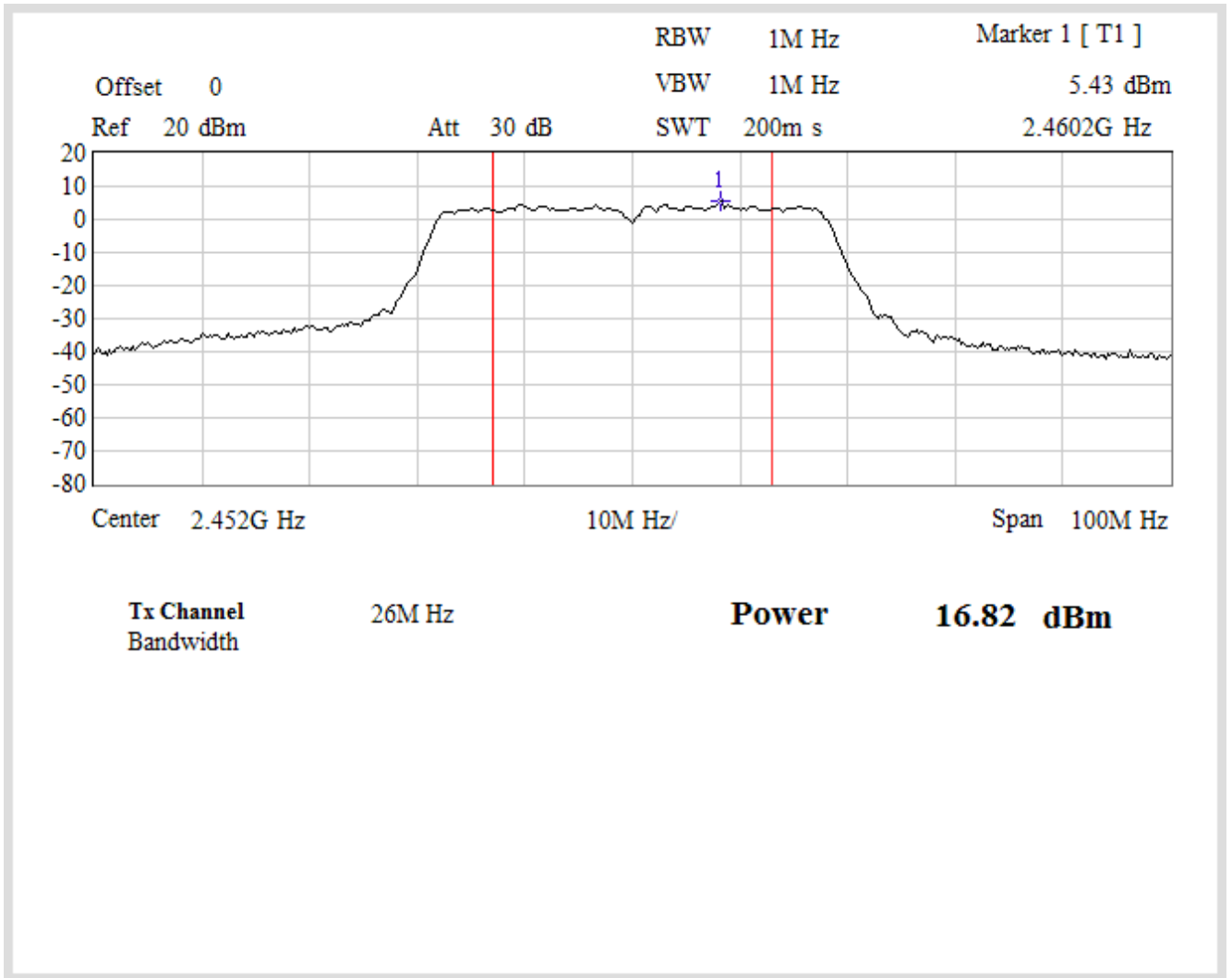

4. Radiated Emission

4.1. Test Equipment

The following test equipment are used during the radiated emission test:

Item		Equipment	Manufacturer	Model No. / Serial No.	Last Cal.
1	X	Test Receiver	R & S	ESCS 30 / 836858/023	Apr., 2008
2	X	Spectrum Analyzer	R & S	FSP40 / 100005	Aug., 2007
3	X	Pre-Amplifier	HP	8449B / 3008A01123	Nov., 2007
4	X	Bilog Antenna	Schaffner	CBL6112B / 2708	Sep., 2007
5	X	Spectrum Analyzer	Advantest	R3162 / 121200166	Feb., 2008
6	X	Pre-Amplifier	Quietek	AP-025C / 002	N/A
7	X	Horn Antenna	Electro Metrics	EM-6961 / 103325	Mar., 2008
8		No.2 OATS			Sep., 2007

- Note: 1. All equipments that need to calibrate are with calibration period of 1 year.
 2. "N/A" Ca1.Date is used to Pre-test, not final test.

4.2. Test Setup

Under 1GHz Test Setup:

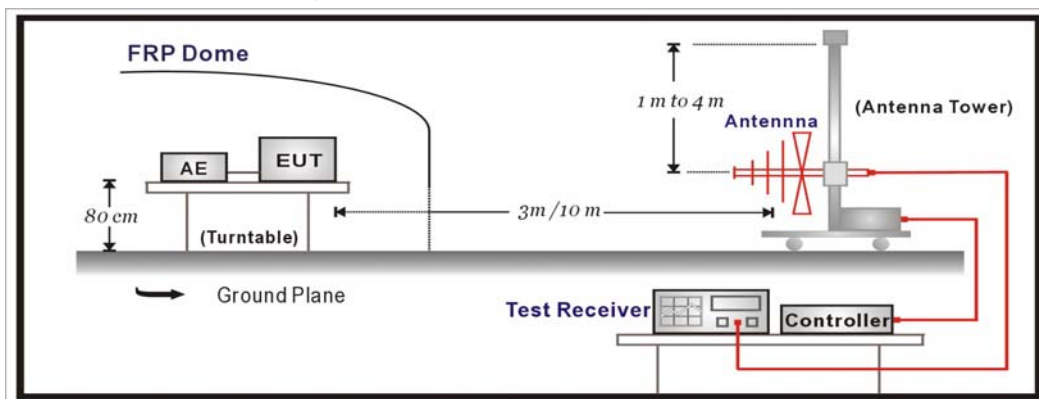

Above 1GHz Test Setup:

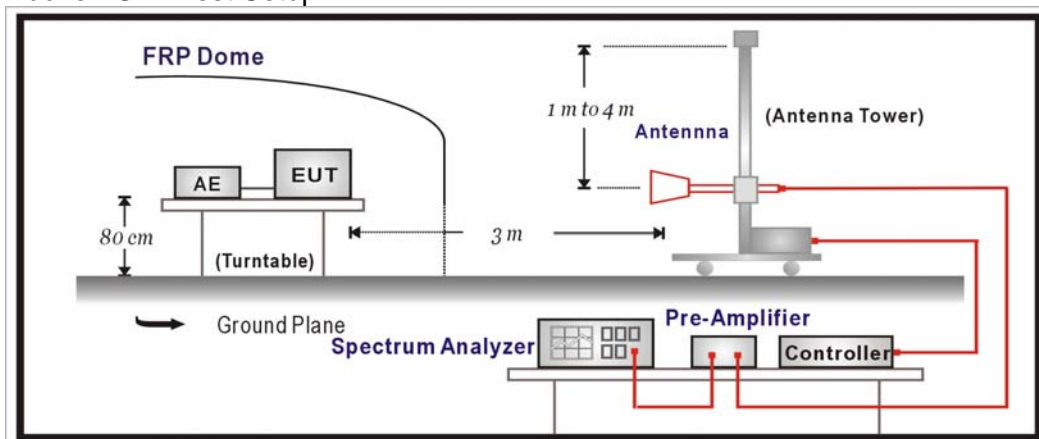

4.3. Limits

➤ **General Radiated Emission Limits**

Emissions radiated outside of the specified frequency bands, except for harmonics, shall be attenuated by at least 20dB below the level of the fundamental or to the general radiated emission limits in paragraph 15.209, whichever is the lesser attenuation.

RSS-210 Section 6.2.1 Limits (FCC 15.209)		
Frequency MHz	uV/m @3m	dBuV/m@3m
30-88	100	40
88-216	150	43.5
216-960	200	46
Above 960	500	54

- Remarks :
1. RF Voltage (dBuV) = 20 log RF Voltage (uV)
 2. In the Above Table, the tighter limit applies at the band edges.
 3. Distance refers to the distance in meters between the measuring instrument antenna and the closed point of any part of the device or system.

4.4. Test Procedure

The EUT and its simulators are placed on a turn table which is 0.8 meter above ground. The turn table can rotate 360 degrees to determine the position of the maximum emission level. The EUT was positioned such that the distance from antenna to the EUT was 3 meters.

The antenna can move up and down between 1 meter and 4 meters to find out the maximum emission level.

Both horizontal and vertical polarization of the antenna are set on measurement. In order to find the maximum emission, all of the interface cables must be manipulated according to

ANSI C63.4: 2003 on radiated measurement.

The additional latch filter below 1GHz was used to measure the level of harmonics radiated emission during field strength of harmonics measurement.

The bandwidth below 1GHz setting on the field strength meter (R&S Test Receiver ESCS 30)is 120 kHz, above 1GHz are 1 MHz.

The frequency range from 30MHz to 10th harmonics is checked.

4.5. Uncertainty

The measurement uncertainty

30MHz~1GHz as ±3.19dB

1GHz~26.5Ghz as ±3.9dB

4.6. Test Result 30MHz-1GHz Spurious

Site : Site 2	Time : 2008/03/28 - 17:51
Limit : FCC_CLASS_B_03M_QP	Margin : 6
EUT : WIRELESS G ADSL2+ MODEM ROUTER	Probe : CB3_FCC_30-1G(2007) - HORIZONTAL
Power : AC 120V/60Hz	Note : Mode 1: Transmit (AMIGO)-B (AC)

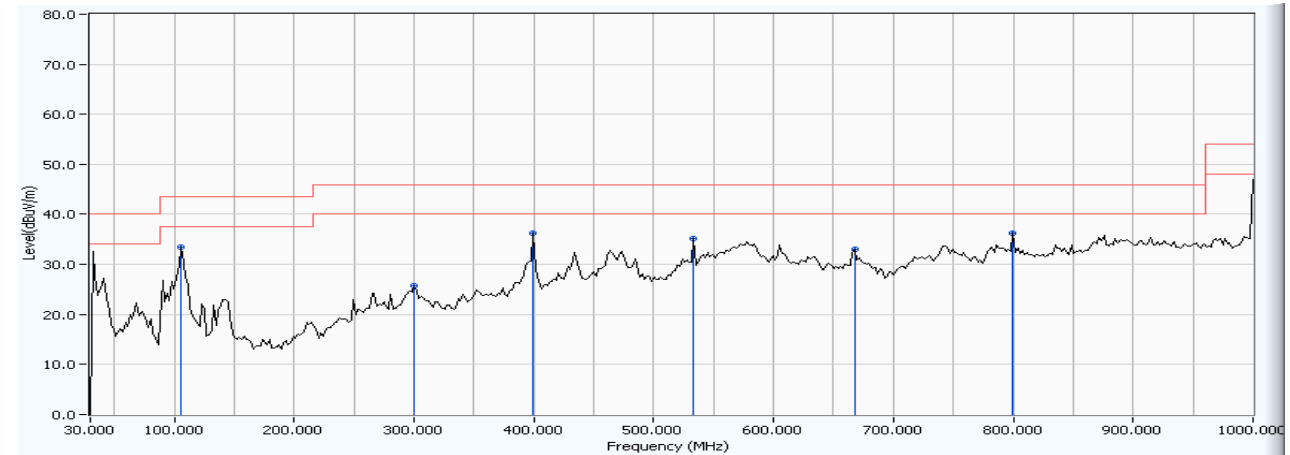

	Frequency (MHz)	Correct Factor (dB)	Reading Level (dBuV)	Measure Level (dBuV/m)	Margin (dB)	Limit (dBuV/m)	Detector Type
1	105.812	1.255	32.268	33.524	-9.976	43.500	QUASI-PEAK
2	300.200	6.038	19.598	25.636	-20.364	46.000	QUASI-PEAK
3	* 399.339	10.661	25.683	36.344	-9.656	46.000	QUASI-PEAK
4	533.467	9.938	25.160	35.098	-10.902	46.000	QUASI-PEAK
5	667.595	10.493	22.609	33.102	-12.898	46.000	QUASI-PEAK
6	799.780	12.186	24.009	36.195	-9.805	46.000	QUASI-PEAK

Note:

1. All Reading Levels are Quasi-Peak value.
2. “ * ”, means this data is the worst emission level.
3. Measurement Level = Reading Level + Correct Factor.

Site : Site 2	Time : 2008/03/28 - 18:01
Limit : FCC_CLASS_B_03M_QP	Margin : 6
EUT : WIRELESS G ADSL2+ MODEM ROUTER	Probe : CB3_FCC_30-1G(2007) - VERTICAL
Power : AC 120V/60Hz	Note : Mode 1: Transmit (AMIGO)-B (AC)

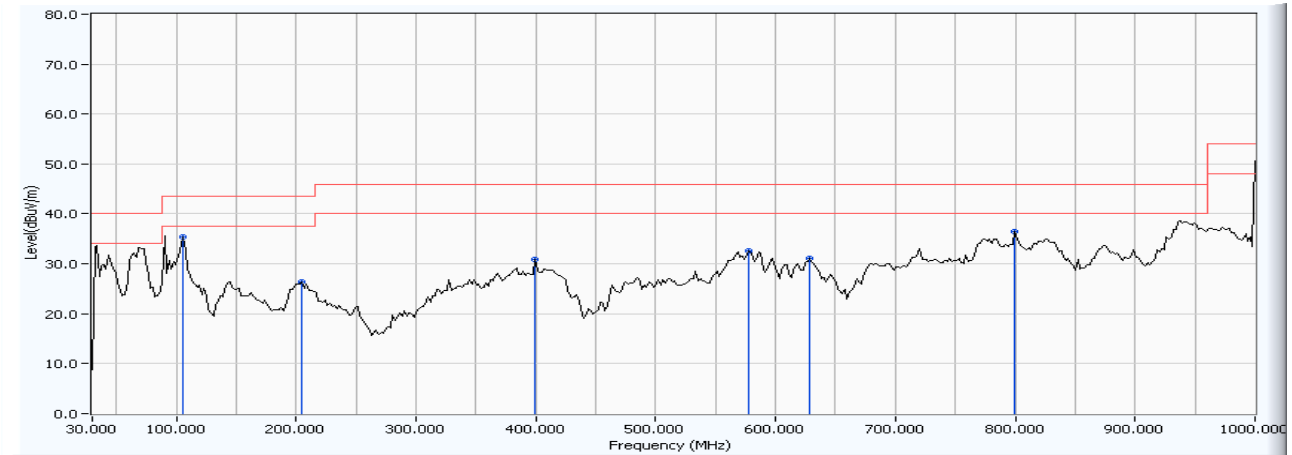

		Frequency (MHz)	Correct Factor (dB)	Reading Level (dBuV)	Measure Level (dBuV/m)	Margin (dB)	Limit (dBuV/m)	Detector Type
1	*	105.812	9.512	25.845	35.358	-8.142	43.500	QUASI-PEAK
2		204.950	6.112	20.321	26.434	-17.066	43.500	QUASI-PEAK
3		399.339	9.047	21.918	30.966	-15.034	46.000	QUASI-PEAK
4		578.176	13.025	19.632	32.656	-13.344	46.000	QUASI-PEAK
5		628.717	10.817	20.356	31.173	-14.827	46.000	QUASI-PEAK
6		799.780	13.596	22.905	36.501	-9.499	46.000	QUASI-PEAK

Note:

1. All Reading Levels are Quasi-Peak value.
2. “ * ”, means this data is the worst emission level.
3. Measurement Level = Reading Level + Correct Factor.

Site : Site 2	Time : 2008/03/28 - 18:10
Limit : FCC_CLASS_B_03M_QP	Margin : 6
EUT : WIRELESS G ADSL2+ MODEM ROUTER	Probe : CB3_FCC_30-1G(2007) - HORIZONTAL
Power : AC 120V/60Hz	Note : Mode 1: Transmit (AMIGO)-G (AC)

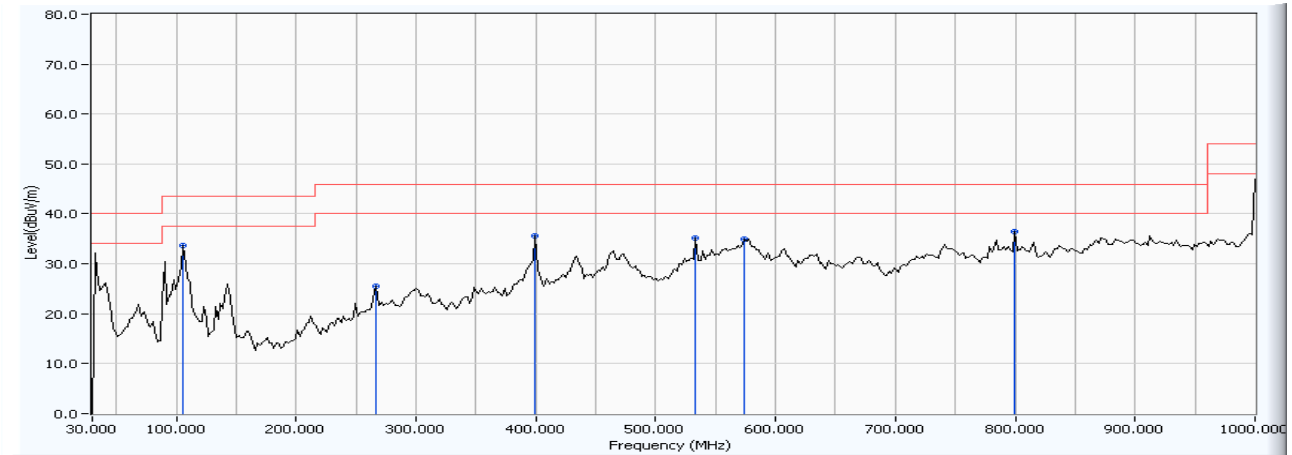

		Frequency (MHz)	Correct Factor (dB)	Reading Level (dBuV)	Measure Level (dBuV/m)	Margin (dB)	Limit (dBuV/m)	Detector Type
1		105.812	1.255	32.365	33.621	-9.879	43.500	QUASI-PEAK
2		267.154	2.430	23.008	25.438	-20.562	46.000	QUASI-PEAK
3		399.339	10.661	25.028	35.689	-10.311	46.000	QUASI-PEAK
4		533.467	9.938	25.333	35.271	-10.729	46.000	QUASI-PEAK
5		574.289	13.770	21.129	34.899	-11.101	46.000	QUASI-PEAK
6	*	799.780	12.186	24.382	36.568	-9.432	46.000	QUASI-PEAK

Note:

1. All Reading Levels are Quasi-Peak value.
2. “ * ”, means this data is the worst emission level.
3. Measurement Level = Reading Level + Correct Factor.

Site : Site 2	Time : 2008/03/28 - 18:20
Limit : FCC_CLASS_B_03M_QP	Margin : 6
EUT : WIRELESS G ADSL2+ MODEM ROUTER	Probe : CB3_FCC_30-1G(2007) - VERTICAL
Power : AC 120V/60Hz	Note : Mode 1: Transmit (AMIGO)-G (AC)

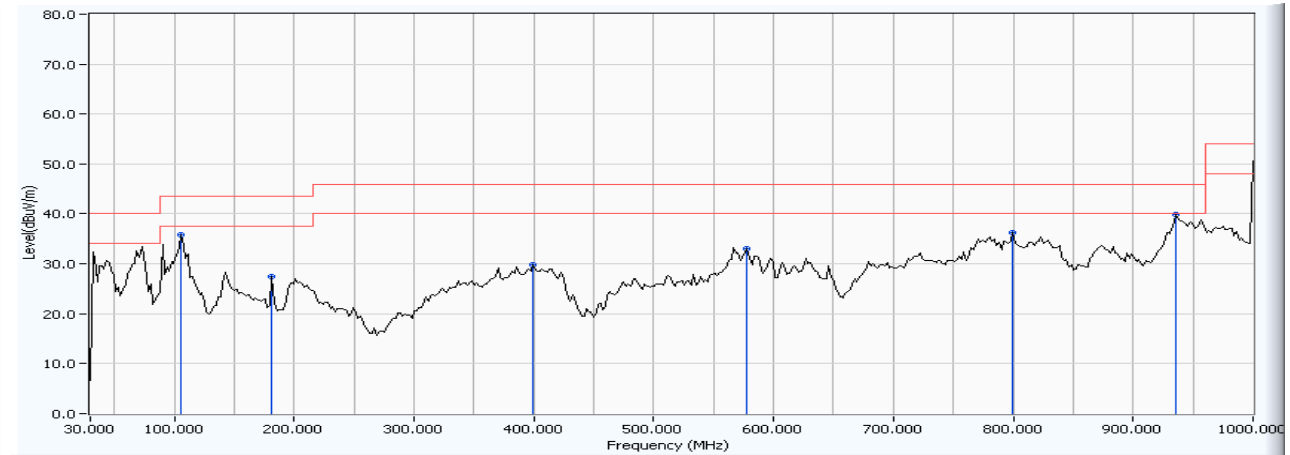

	Frequency (MHz)	Correct Factor (dB)	Reading Level (dBuV)	Measure Level (dBuV/m)	Margin (dB)	Limit (dBuV/m)	Detector Type
1	105.812	9.512	26.250	35.763	-7.737	43.500	QUASI-PEAK
2	181.623	0.693	26.755	27.448	-16.052	43.500	QUASI-PEAK
3	399.339	9.047	20.669	29.717	-16.283	46.000	QUASI-PEAK
4	578.176	13.025	20.055	33.079	-12.921	46.000	QUASI-PEAK
5	799.780	13.596	22.732	36.328	-9.672	46.000	QUASI-PEAK
6	* 935.852	16.809	23.092	39.901	-6.099	46.000	QUASI-PEAK

Note:

1. All Reading Levels are Quasi-Peak value.
2. “ * ”, means this data is the worst emission level.
3. Measurement Level = Reading Level + Correct Factor.

Site : Site 2	Time : 2008/03/31 - 14:31
Limit : FCC_CLASS_B_03M_QP	Margin : 6
EUT : WIRELESS G ADSL2+ MODEM ROUTER	Probe : CB3_FCC_30-1G(2007) - HORIZONTAL
Power : AC 120V/60Hz	Note : Mode 1: Transmit (AMIGO)-N-20M (AC)

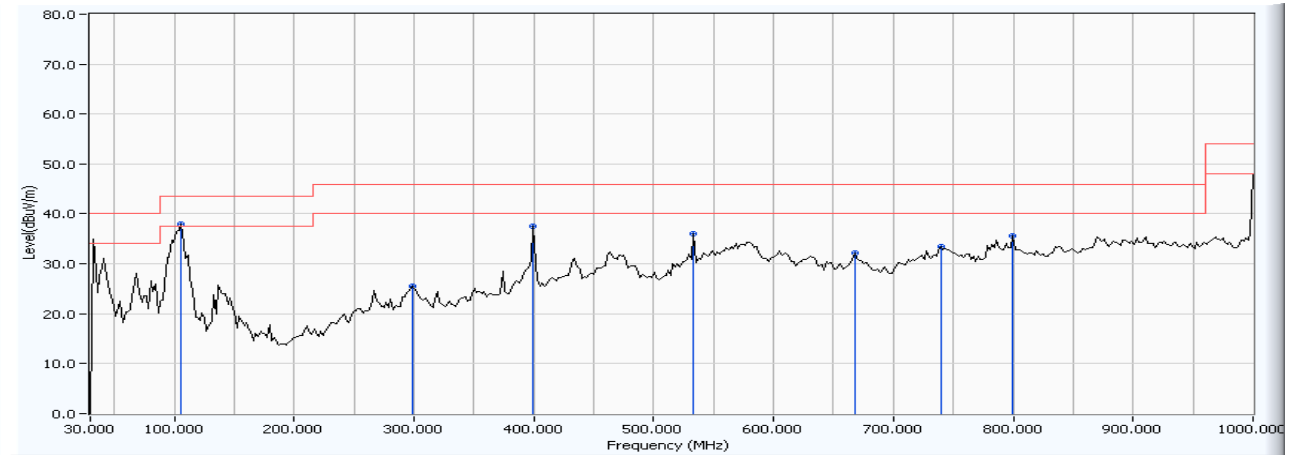

		Frequency (MHz)	Correct Factor (dB)	Reading Level (dBuV)	Measure Level (dBuV/m)	Margin (dB)	Limit (dBuV/m)	Detector Type
1	*	105.812	1.255	36.675	37.931	-5.569	43.500	QUASI-PEAK
2		298.257	5.778	19.778	25.556	-20.444	46.000	QUASI-PEAK
3		399.339	10.661	26.828	37.489	-8.511	46.000	QUASI-PEAK
4		533.467	9.938	26.089	36.027	-9.973	46.000	QUASI-PEAK
5		667.595	10.493	21.621	32.114	-13.886	46.000	QUASI-PEAK
6		739.519	12.948	20.568	33.516	-12.484	46.000	QUASI-PEAK
7		799.780	12.186	23.487	35.673	-10.327	46.000	QUASI-PEAK

Note:

1. All Reading Levels are Quasi-Peak value.
2. “ * ”, means this data is the worst emission level.
3. Measurement Level = Reading Level + Correct Factor.

Site : Site 2	Time : 2008/03/31 - 14:39
Limit : FCC_CLASS_B_03M_QP	Margin : 6
EUT : WIRELESS G ADSL2+ MODEM ROUTER	Probe : CB3_FCC_30-1G(2007) - VERTICAL
Power : AC 120V/60Hz	Note : Mode 1: Transmit (AMIGO)-N-20M (AC)

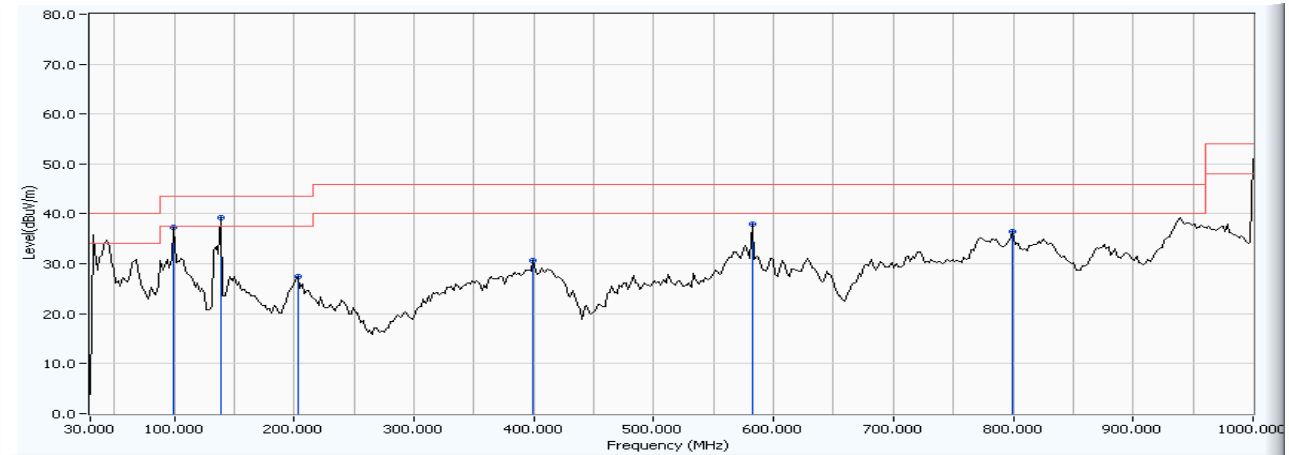

	Frequency (MHz)	Correct Factor (dB)	Reading Level (dBuV)	Measure Level (dBuV/m)	Margin (dB)	Limit (dBuV/m)	Detector Type
1	99.980	8.203	29.126	37.329	-6.171	43.500	QUASI-PEAK
2	* 138.858	2.318	36.964	39.282	-4.218	43.500	QUASI-PEAK
3	203.006	6.513	20.999	27.512	-15.988	43.500	QUASI-PEAK
4	399.339	9.047	21.584	30.632	-15.368	46.000	QUASI-PEAK
5	582.064	9.641	28.318	37.959	-8.041	46.000	QUASI-PEAK
6	799.780	13.596	22.824	36.420	-9.580	46.000	QUASI-PEAK

Note:

1. All Reading Levels are Quasi-Peak value.
2. “ * ”, means this data is the worst emission level.
3. Measurement Level = Reading Level + Correct Factor.

Site : Site 2	Time : 2008/04/01 - 10:14
Limit : FCC_CLASS_B_03M_QP	Margin : 6
EUT : WIRELESS G ADSL2+ MODEM ROUTER	Probe : CB3_FCC_30-1G(2007) - HORIZONTAL
Power : AC 120V/60Hz	Note : Mode 1: Transmit (AMIGO)-N-40M (AC)

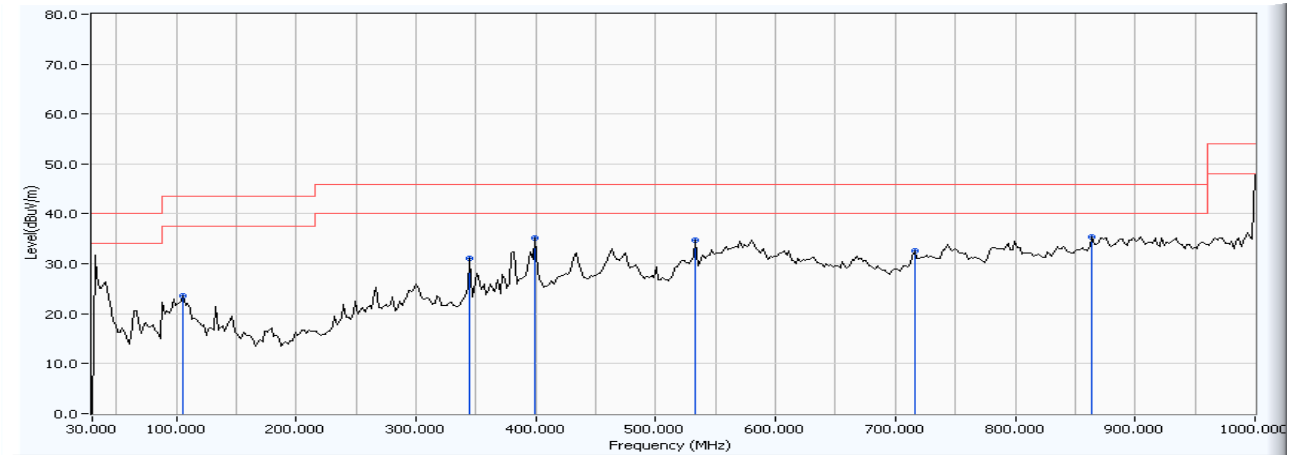

	Frequency (MHz)	Correct Factor (dB)	Reading Level (dBuV)	Measure Level (dBuV/m)	Margin (dB)	Limit (dBuV/m)	Detector Type
1	105.812	1.255	22.400	23.656	-19.844	43.500	QUASI-PEAK
2	344.910	2.789	28.361	31.150	-14.850	46.000	QUASI-PEAK
3	399.339	10.661	24.620	35.281	-10.719	46.000	QUASI-PEAK
4	533.467	9.938	24.779	34.717	-11.283	46.000	QUASI-PEAK
5	716.192	10.819	21.707	32.526	-13.474	46.000	QUASI-PEAK
6	* 863.928	13.096	22.201	35.297	-10.703	46.000	QUASI-PEAK

Note:

1. All Reading Levels are Quasi-Peak value.
2. “ * ”, means this data is the worst emission level.
3. Measurement Level = Reading Level + Correct Factor.

Site : Site 2	Time : 2008/04/01 - 10:08
Limit : FCC_CLASS_B_03M_QP	Margin : 6
EUT : WIRELESS G ADSL2+ MODEM ROUTER	Probe : CB3_FCC_30-1G(2007) - VERTICAL
Power : AC 120V/60Hz	Note : Mode 1: Transmit (AMIGO)-N-40M (AC)

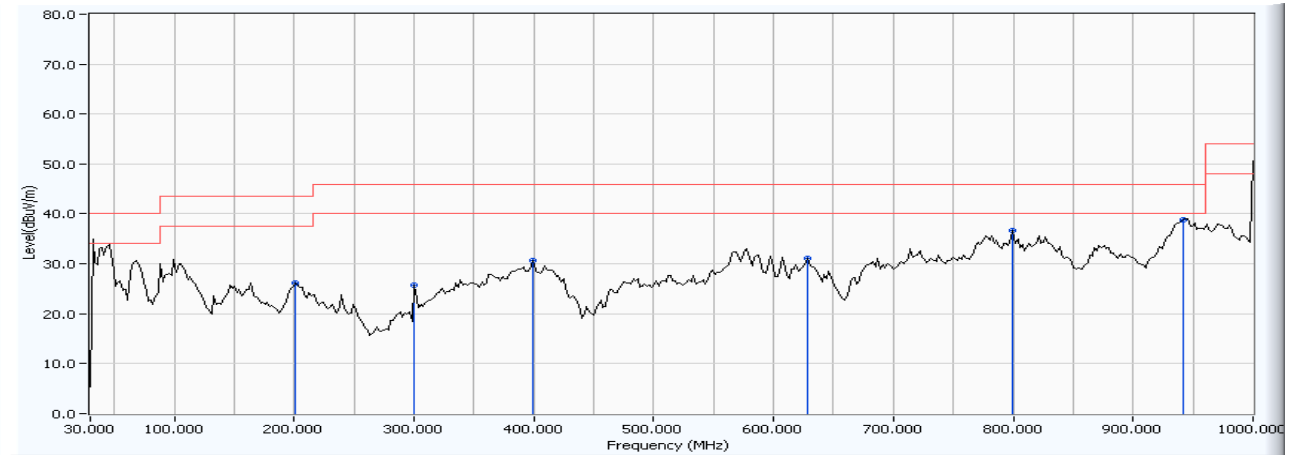

	Frequency (MHz)	Correct Factor (dB)	Reading Level (dBuV)	Measure Level (dBuV/m)	Margin (dB)	Limit (dBuV/m)	Detector Type
1	201.062	6.700	19.427	26.127	-17.373	43.500	QUASI-PEAK
2	300.200	1.034	24.766	25.800	-20.200	46.000	QUASI-PEAK
3	399.339	9.047	21.721	30.769	-15.231	46.000	QUASI-PEAK
4	628.717	10.817	20.374	31.191	-14.809	46.000	QUASI-PEAK
5	799.780	13.596	22.999	36.595	-9.405	46.000	QUASI-PEAK
6	* 941.683	17.406	21.432	38.838	-7.162	46.000	QUASI-PEAK

Note:

1. All Reading Levels are Quasi-Peak value.
2. “ * ”, means this data is the worst emission level.
3. Measurement Level = Reading Level + Correct Factor.

Site : Site 2	Time : 2008/06/18 - 09:55
Limit : FCC_CLASS_B_03M_QP	Margin : 6
Probe : CB3_FCC_30-1G(2007) - HORIZONTAL	Power : AC 120V/60Hz
EUT : WIRELESS G ADSL2+ MODEM ROUTER	Note : Mode 2: Transmit (FAIRWAY)-B (DC)

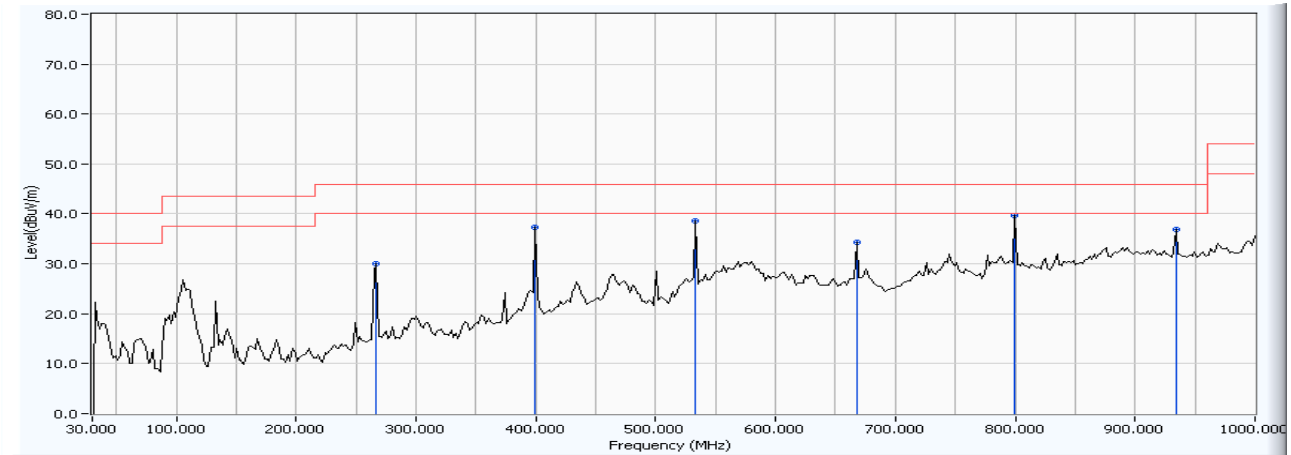

	Frequency (MHz)	Correct Factor (dB)	Reading Level (dBuV)	Measure Level (dBuV/m)	Margin (dB)	Limit (dBuV/m)	Detector Type
1	267.154	-3.955	33.944	29.988	-16.012	46.000	QUASI-PEAK
2	399.339	5.189	32.187	37.376	-8.624	46.000	QUASI-PEAK
3	533.467	5.528	33.128	38.656	-7.344	46.000	QUASI-PEAK
4	667.595	6.963	27.405	34.368	-11.632	46.000	QUASI-PEAK
5	* 799.780	9.412	30.218	39.630	-6.370	46.000	QUASI-PEAK
6	933.908	10.692	26.169	36.860	-9.140	46.000	QUASI-PEAK

Note:

1. All Reading Levels are Quasi-Peak value.
2. “ * ”, means this data is the worst emission level.
3. Measurement Level = Reading Level + Correct Factor.

Site : Site 2	Time : 2008/06/18 - 10:02
Limit : FCC_CLASS_B_03M_QP	Margin : 6
Probe : CB3_FCC_30-1G(2007) - VERTICAL	Power : AC 120V/60Hz
EUT : WIRELESS G ADSL2+ MODEM ROUTER	Note : Mode 2: Transmit (FAIRWAY)-B (DC)

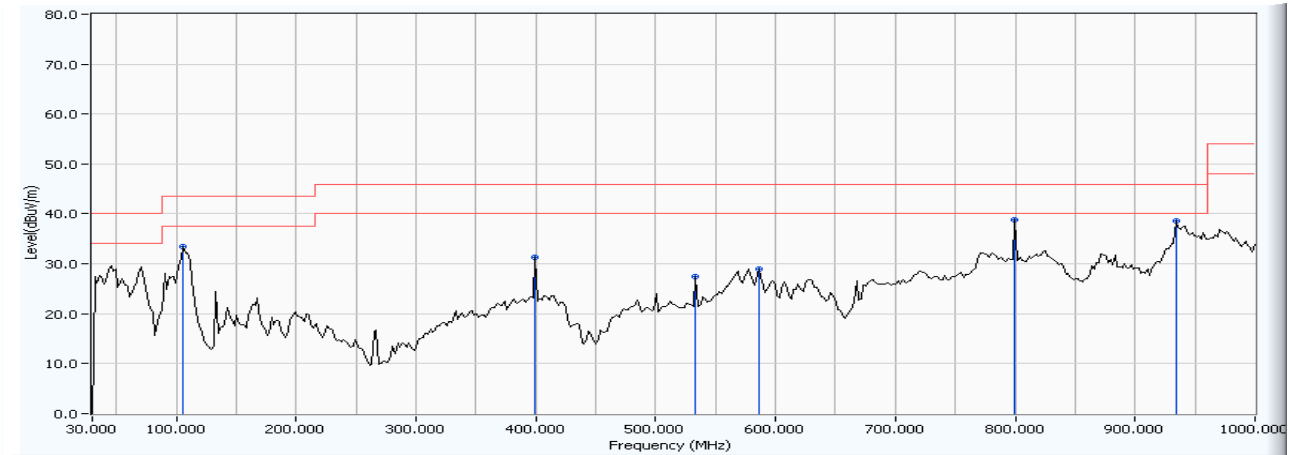

	Frequency (MHz)	Correct Factor (dB)	Reading Level (dBuV)	Measure Level (dBuV/m)	Margin (dB)	Limit (dBuV/m)	Detector Type
1	105.812	1.859	31.690	33.549	-9.951	43.500	QUASI-PEAK
2	399.339	3.575	27.727	31.302	-14.698	46.000	QUASI-PEAK
3	533.467	1.403	26.106	27.510	-18.490	46.000	QUASI-PEAK
4	585.952	7.825	21.119	28.944	-17.056	46.000	QUASI-PEAK
5	* 799.780	10.822	27.985	38.807	-7.193	46.000	QUASI-PEAK
6	933.908	14.040	24.621	38.661	-7.339	46.000	QUASI-PEAK

Note:

1. All Reading Levels are Quasi-Peak value.
2. “ * ”, means this data is the worst emission level.
3. Measurement Level = Reading Level + Correct Factor.

Site : Site 2	Time : 2008/06/18 - 10:10
Limit : FCC_CLASS_B_03M_QP	Margin : 6
Probe : CB3_FCC_30-1G(2007) - HORIZONTAL	Power : AC 120V/60Hz
EUT : WIRELESS G ADSL2+ MODEM ROUTER	Note : Mode 2: Transmit (FAIRWAY)-G (DC)

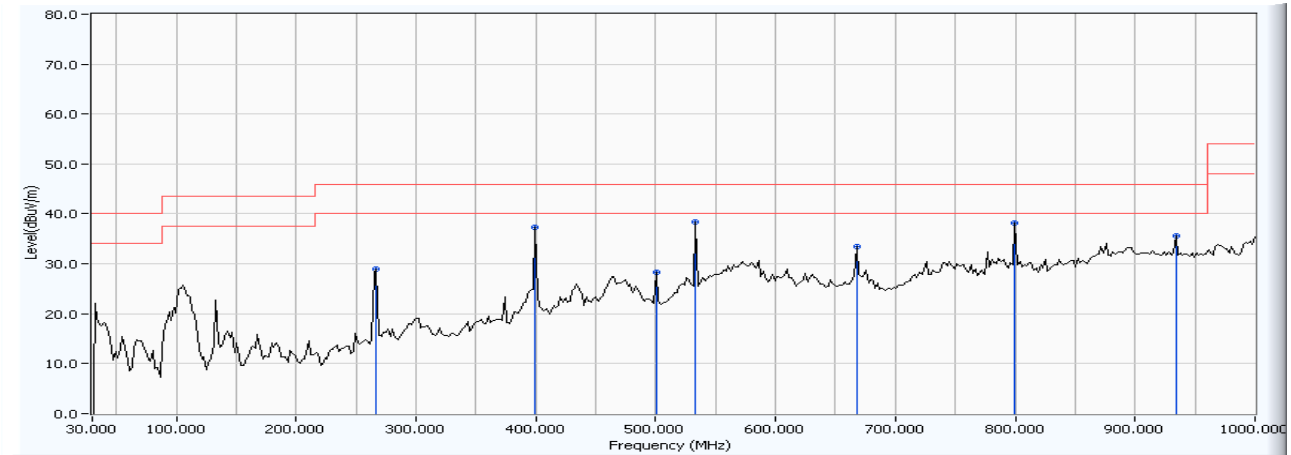

	Frequency (MHz)	Correct Factor (dB)	Reading Level (dBuV)	Measure Level (dBuV/m)	Margin (dB)	Limit (dBuV/m)	Detector Type
1	267.154	-3.955	32.883	28.927	-17.073	46.000	QUASI-PEAK
2	399.339	5.189	32.175	37.364	-8.636	46.000	QUASI-PEAK
3	500.421	2.071	26.303	28.374	-17.626	46.000	QUASI-PEAK
4	* 533.467	5.528	32.862	38.390	-7.610	46.000	QUASI-PEAK
5	667.595	6.963	26.419	33.382	-12.618	46.000	QUASI-PEAK
6	799.780	9.412	28.846	38.258	-7.742	46.000	QUASI-PEAK
7	933.908	10.692	24.823	35.514	-10.486	46.000	QUASI-PEAK

Note:

1. All Reading Levels are Quasi-Peak value.
2. “ * ”, means this data is the worst emission level.
3. Measurement Level = Reading Level + Correct Factor.

Site : Site 2	Time : 2008/06/18 - 10:14
Limit : FCC_CLASS_B_03M_QP	Margin : 6
Probe : CB3_FCC_30-1G(2007) - VERTICAL	Power : AC 120V/60Hz
EUT : WIRELESS G ADSL2+ MODEM ROUTER	Note : Mode 2: Transmit (FAIRWAY)-G (DC)

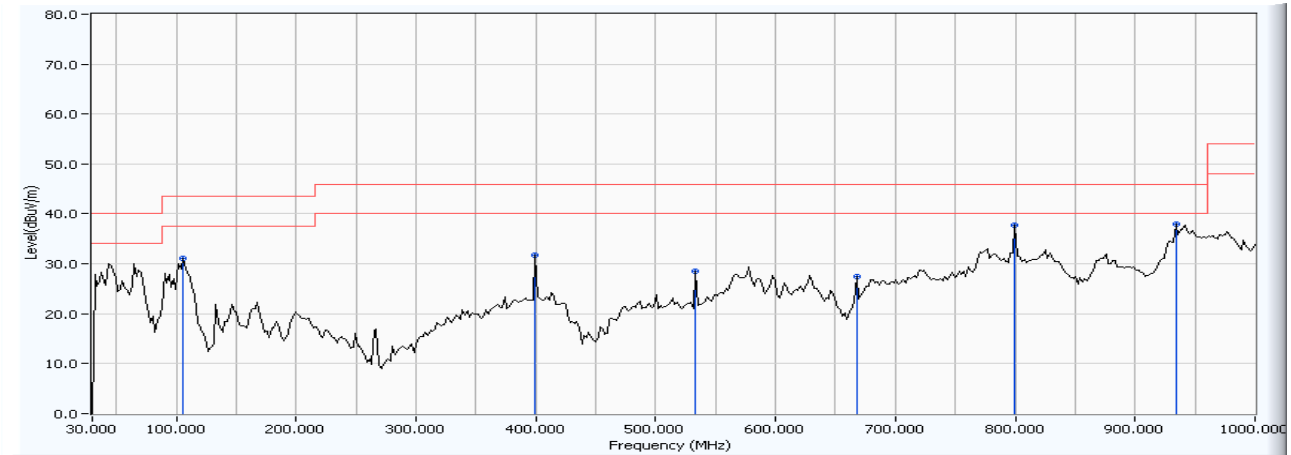

	Frequency (MHz)	Correct Factor (dB)	Reading Level (dBuV)	Measure Level (dBuV/m)	Margin (dB)	Limit (dBuV/m)	Detector Type
1	105.812	1.859	29.207	31.066	-12.434	43.500	QUASI-PEAK
2	399.339	3.575	28.123	31.698	-14.302	46.000	QUASI-PEAK
3	533.467	1.403	27.124	28.528	-17.472	46.000	QUASI-PEAK
4	667.595	2.373	25.154	27.527	-18.473	46.000	QUASI-PEAK
5	799.780	10.822	27.005	37.827	-8.173	46.000	QUASI-PEAK
6	* 933.908	14.040	23.875	37.915	-8.085	46.000	QUASI-PEAK

Note:

1. All Reading Levels are Quasi-Peak value.
2. “ * ”, means this data is the worst emission level.
3. Measurement Level = Reading Level + Correct Factor.

Site : Site 2	Time : 2008/06/18 - 10:21
Limit : FCC_CLASS_B_03M_QP	Margin : 6
Probe : CB3_FCC_30-1G(2007) - HORIZONTAL	Power : AC 120V/60Hz
EUT : WIRELESS G ADSL2+ MODEM ROUTER	Note : Mode 2: Transmit (FAIRWAY)-N-20M(DC)

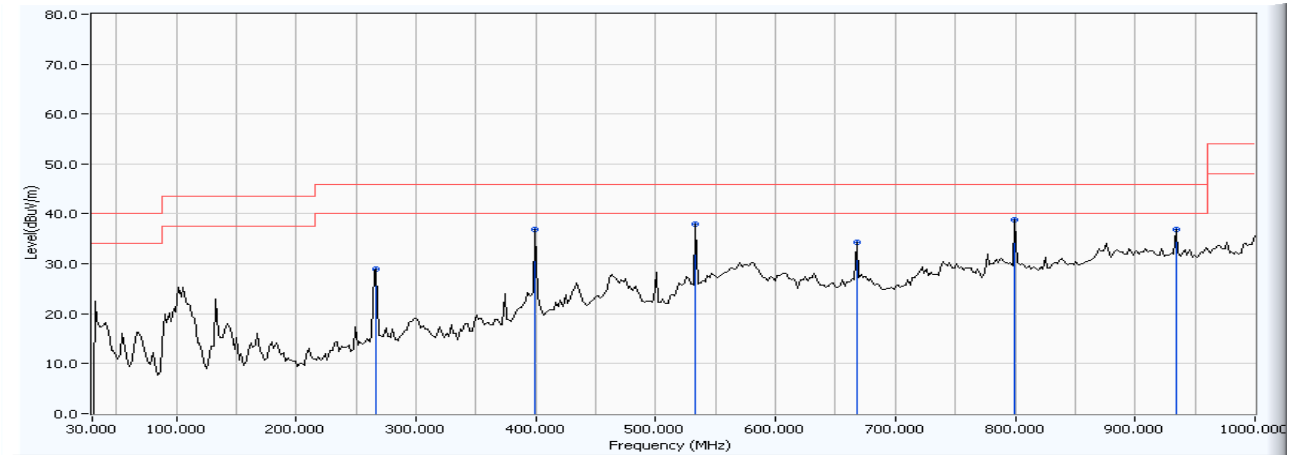

	Frequency (MHz)	Correct Factor (dB)	Reading Level (dBuV)	Measure Level (dBuV/m)	Margin (dB)	Limit (dBuV/m)	Detector Type
1	267.154	-3.955	32.840	28.884	-17.116	46.000	QUASI-PEAK
2	399.339	5.189	31.664	36.853	-9.147	46.000	QUASI-PEAK
3	533.467	5.528	32.455	37.983	-8.017	46.000	QUASI-PEAK
4	667.595	6.963	27.409	34.372	-11.628	46.000	QUASI-PEAK
5	* 799.780	9.412	29.411	38.823	-7.177	46.000	QUASI-PEAK
6	933.908	10.692	26.161	36.852	-9.148	46.000	QUASI-PEAK

Note:

1. All Reading Levels are Quasi-Peak value.
2. “ * ”, means this data is the worst emission level.
3. Measurement Level = Reading Level + Correct Factor.

Site : Site 2	Time : 2008/06/18 - 10:27
Limit : FCC_CLASS_B_03M_QP	Margin : 6
Probe : CB3_FCC_30-1G(2007) - VERTICAL	Power : AC 120V/60Hz
EUT : WIRELESS G ADSL2+ MODEM ROUTER	Note : Mode 2: Transmit (FAIRWAY)-N-20M(DC)

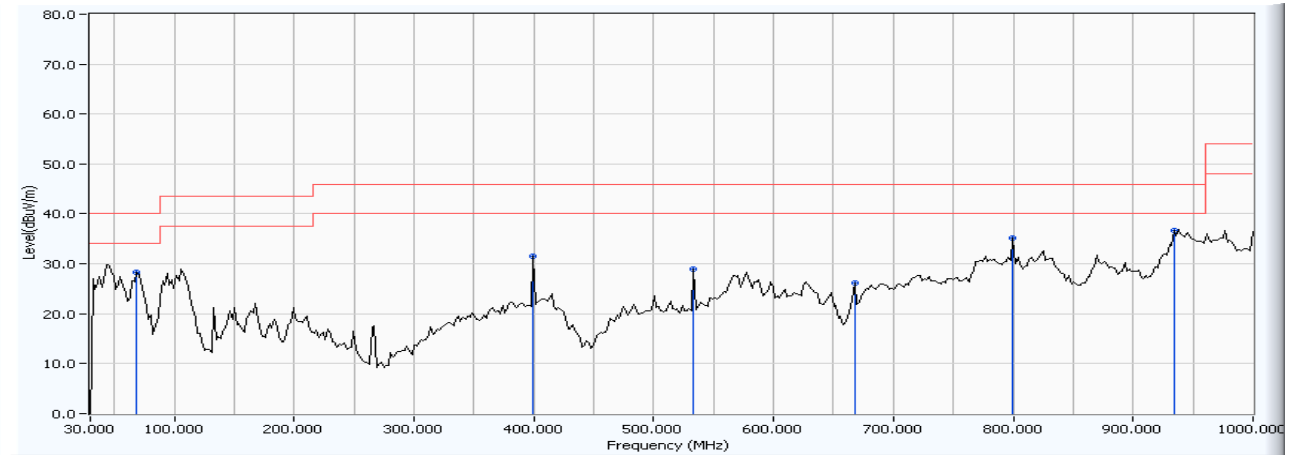

		Frequency (MHz)	Correct Factor (dB)	Reading Level (dBuV)	Measure Level (dBuV/m)	Margin (dB)	Limit (dBuV/m)	Detector Type
1		68.878	-6.279	34.627	28.347	-11.653	40.000	QUASI-PEAK
2		399.339	3.575	27.850	31.425	-14.575	46.000	QUASI-PEAK
3		533.467	1.403	27.500	28.904	-17.096	46.000	QUASI-PEAK
4		667.595	2.373	23.889	26.262	-19.738	46.000	QUASI-PEAK
5		799.780	10.822	24.401	35.223	-10.777	46.000	QUASI-PEAK
6	*	933.908	14.040	22.723	36.763	-9.237	46.000	QUASI-PEAK

Note:

1. All Reading Levels are Quasi-Peak value.
2. “ * ”, means this data is the worst emission level.
3. Measurement Level = Reading Level + Correct Factor.

Site : Site 2	Time : 2008/06/18 - 10:33
Limit : FCC_CLASS_B_03M_QP	Margin : 6
Probe : CB3_FCC_30-1G(2007) - HORIZONTAL	Power : AC 120V/60Hz
EUT : WIRELESS G ADSL2+ MODEM ROUTER	Note : Mode 2: Transmit (FAIRWAY)-N-40M(DC)

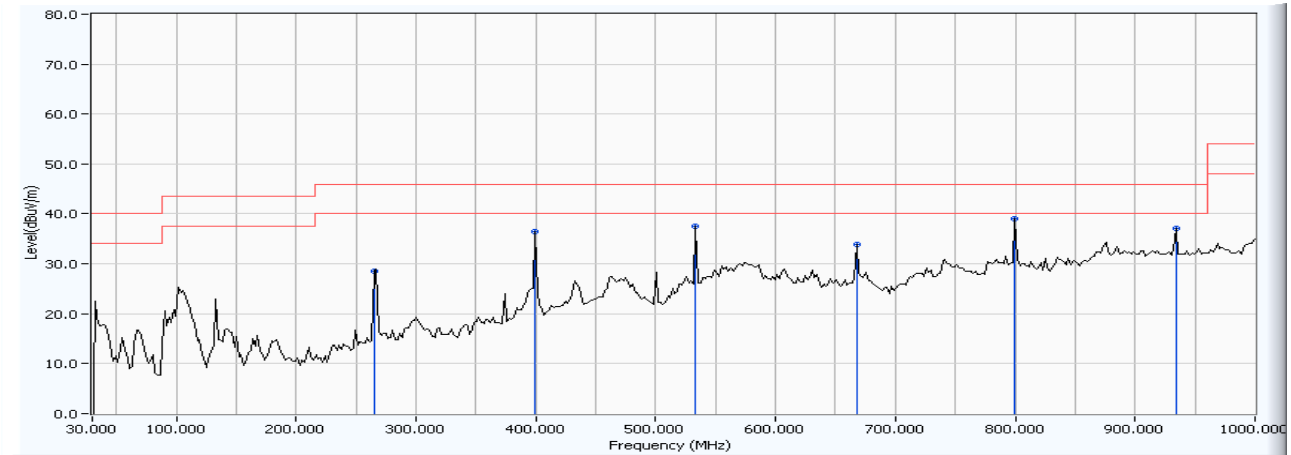

	Frequency (MHz)	Correct Factor (dB)	Reading Level (dBuV)	Measure Level (dBuV/m)	Margin (dB)	Limit (dBuV/m)	Detector Type
1	265.210	-4.086	32.516	28.430	-17.570	46.000	QUASI-PEAK
2	399.339	5.189	31.292	36.481	-9.519	46.000	QUASI-PEAK
3	533.467	5.528	32.105	37.633	-8.367	46.000	QUASI-PEAK
4	667.595	6.963	26.819	33.782	-12.218	46.000	QUASI-PEAK
5	* 799.780	9.412	29.635	39.047	-6.953	46.000	QUASI-PEAK
6	933.908	10.692	26.309	37.000	-9.000	46.000	QUASI-PEAK

Note:

1. All Reading Levels are Quasi-Peak value.
2. “ * ”, means this data is the worst emission level.
3. Measurement Level = Reading Level + Correct Factor.

Site : Site 2	Time : 2008/06/18 - 10:37
Limit : FCC_CLASS_B_03M_QP	Margin : 6
Probe : CB3_FCC_30-1G(2007) - VERTICAL	Power : AC 120V/60Hz
EUT : WIRELESS G ADSL2+ MODEM ROUTER	Note : Mode 2: Transmit (FAIRWAY)-N-40M(DC)

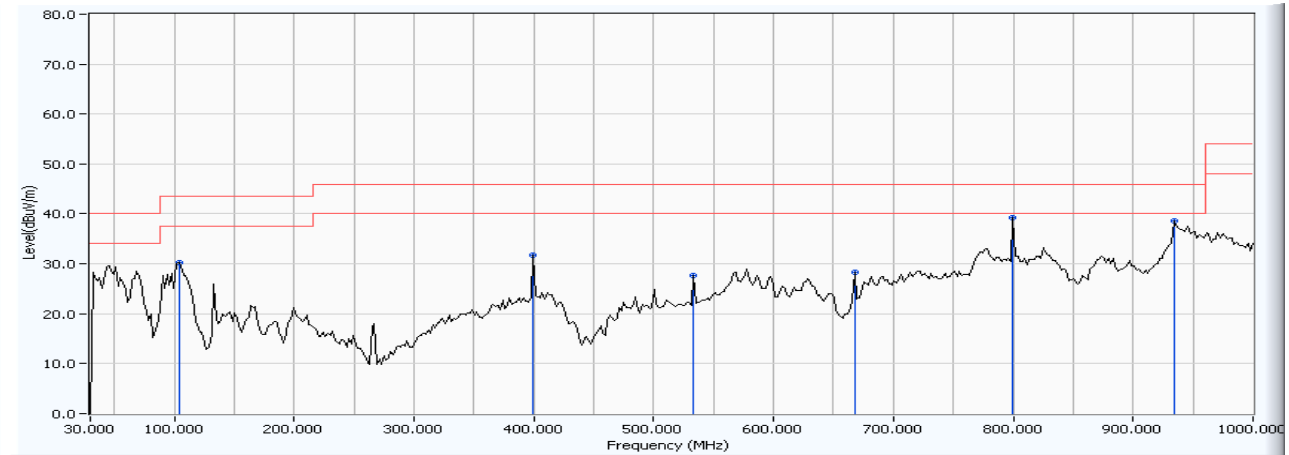

	Frequency (MHz)	Correct Factor (dB)	Reading Level (dBuV)	Measure Level (dBuV/m)	Margin (dB)	Limit (dBuV/m)	Detector Type
1	103.868	1.382	28.804	30.186	-13.314	43.500	QUASI-PEAK
2	399.339	3.575	28.260	31.835	-14.165	46.000	QUASI-PEAK
3	533.467	1.403	26.260	27.664	-18.336	46.000	QUASI-PEAK
4	667.595	2.373	26.008	28.381	-17.619	46.000	QUASI-PEAK
5	* 799.780	10.822	28.437	39.259	-6.741	46.000	QUASI-PEAK
6	933.908	14.040	24.595	38.635	-7.365	46.000	QUASI-PEAK

Note:

1. All Reading Levels are Quasi-Peak value.
2. “ * ”, means this data is the worst emission level.
3. Measurement Level = Reading Level + Correct Factor.

Site : Site 2	Time : 2008/06/19 - 20:45
Limit : FCC_CLASS_B_03M_QP	Margin : 6
Probe : CB3_FCC_30-1G(2007) - HORIZONTAL	Power : AC 120V/60Hz
EUT : WIRELESS G ADSL2+ MODEM ROUTER	Note : Mode 3: Transmit (D-Link)-B (DC)

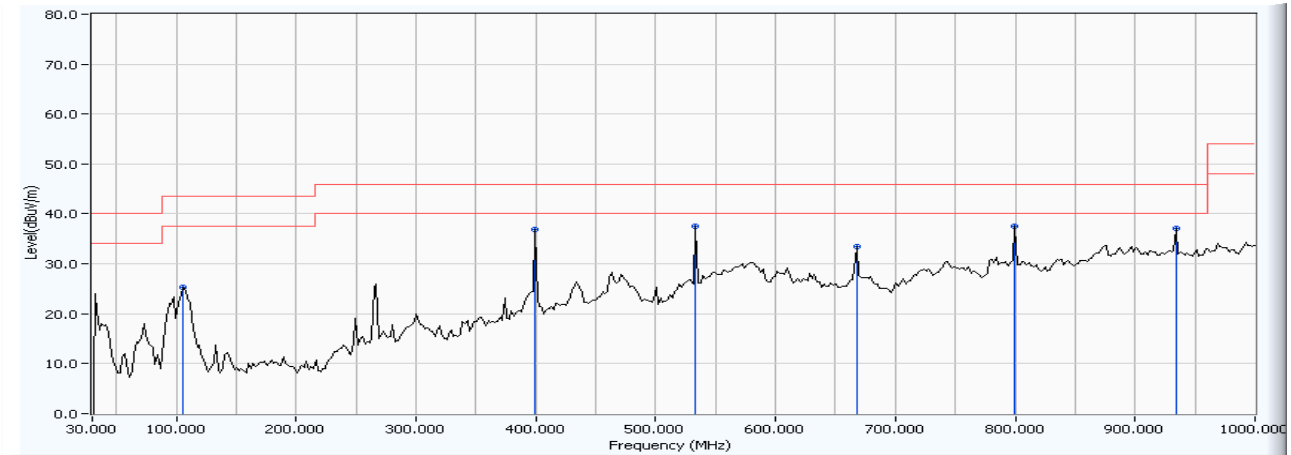

	Frequency (MHz)	Correct Factor (dB)	Reading Level (dBuV)	Measure Level (dBuV/m)	Margin (dB)	Limit (dBuV/m)	Detector Type
1	105.812	-6.398	31.757	25.359	-18.141	43.500	QUASI-PEAK
2	399.339	5.189	31.729	36.918	-9.082	46.000	QUASI-PEAK
3	533.467	5.528	32.010	37.538	-8.462	46.000	QUASI-PEAK
4	667.595	6.963	26.396	33.359	-12.641	46.000	QUASI-PEAK
5	* 799.780	9.412	28.189	37.601	-8.399	46.000	QUASI-PEAK
6	933.908	10.692	26.350	37.041	-8.959	46.000	QUASI-PEAK

Note:

1. All Reading Levels are Quasi-Peak value.
2. “ * ”, means this data is the worst emission level.
3. Measurement Level = Reading Level + Correct Factor.

Site : Site 2	Time : 2008/06/19 - 20:56
Limit : FCC_CLASS_B_03M_QP	Margin : 6
Probe : CB3_FCC_30-1G(2007) - VERTICAL	Power : AC 120V/60Hz
EUT : WIRELESS G ADSL2+ MODEM ROUTER	Note : Mode 3: Transmit (D-Link)-B (DC)

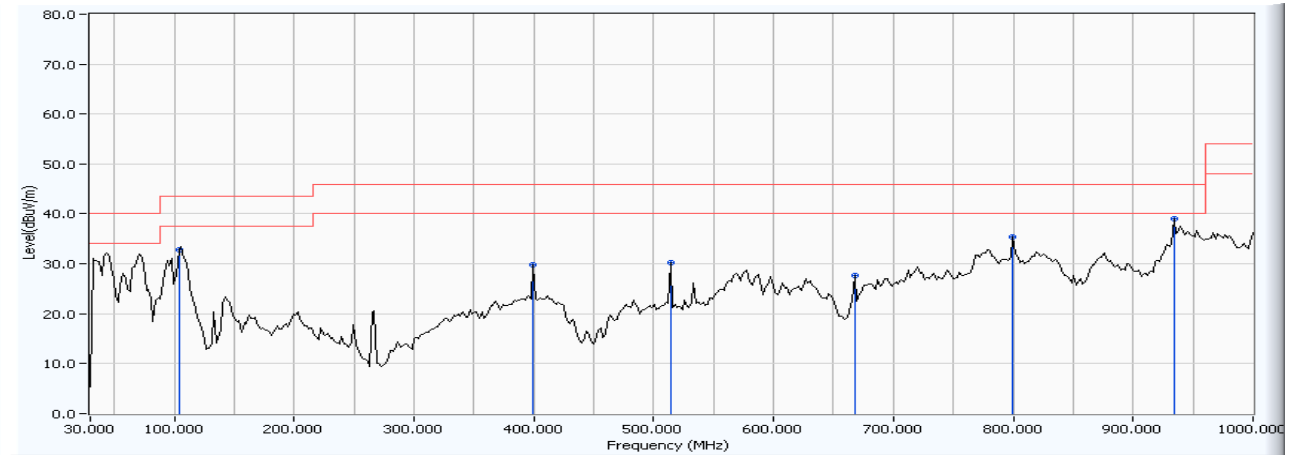

	Frequency (MHz)	Correct Factor (dB)	Reading Level (dBuV)	Measure Level (dBuV/m)	Margin (dB)	Limit (dBuV/m)	Detector Type
1	103.868	1.382	31.326	32.708	-10.792	43.500	QUASI-PEAK
2	399.339	3.575	26.153	29.728	-16.272	46.000	QUASI-PEAK
3	514.028	2.090	28.207	30.297	-15.703	46.000	QUASI-PEAK
4	667.595	2.373	25.286	27.659	-18.341	46.000	QUASI-PEAK
5	799.780	10.822	24.544	35.366	-10.634	46.000	QUASI-PEAK
6	* 933.908	14.040	24.979	39.019	-6.981	46.000	QUASI-PEAK

Note:

1. All Reading Levels are Quasi-Peak value.
2. “ * ”, means this data is the worst emission level.
3. Measurement Level = Reading Level + Correct Factor.

Site : Site 2	Time : 2008/06/19 - 21:03
Limit : FCC_CLASS_B_03M_QP	Margin : 6
Probe : CB3_FCC_30-1G(2007) - HORIZONTAL	Power : AC 120V/60Hz
EUT : WIRELESS G ADSL2+ MODEM ROUTER	Note : Mode 3: Transmit (D-Link)-G (DC)

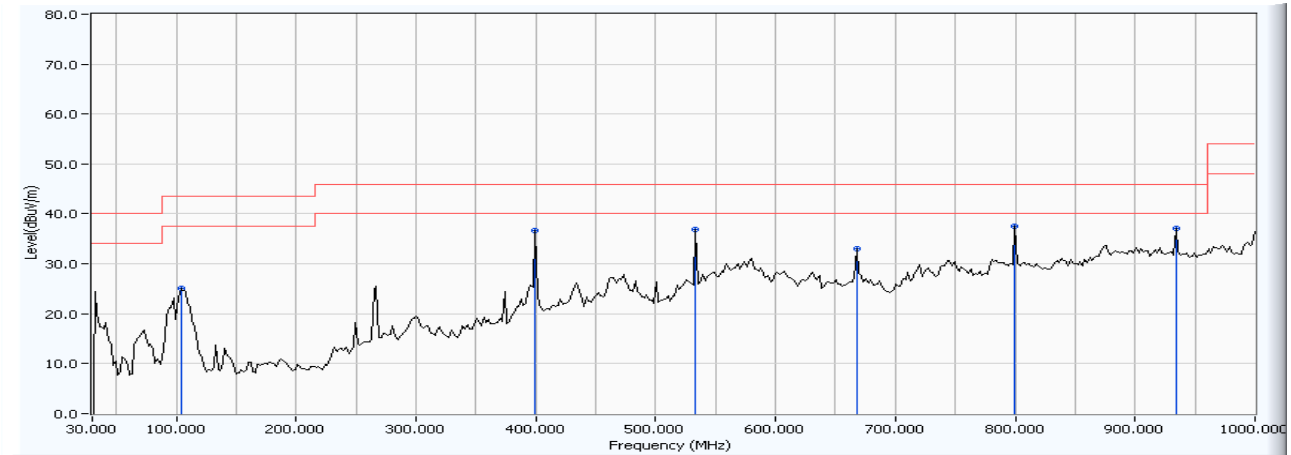

	Frequency (MHz)	Correct Factor (dB)	Reading Level (dBuV)	Measure Level (dBuV/m)	Margin (dB)	Limit (dBuV/m)	Detector Type
1	103.868	-6.175	31.190	25.015	-18.485	43.500	QUASI-PEAK
2	399.339	5.189	31.420	36.609	-9.391	46.000	QUASI-PEAK
3	533.467	5.528	31.422	36.950	-9.050	46.000	QUASI-PEAK
4	667.595	6.963	26.166	33.129	-12.871	46.000	QUASI-PEAK
5	* 799.780	9.412	28.203	37.615	-8.385	46.000	QUASI-PEAK
6	933.908	10.692	26.409	37.100	-8.900	46.000	QUASI-PEAK

Note:

1. All Reading Levels are Quasi-Peak value.
2. “ * ”, means this data is the worst emission level.
3. Measurement Level = Reading Level + Correct Factor.

Site : Site 2	Time : 2008/06/19 - 21:07
Limit : FCC_CLASS_B_03M_QP	Margin : 6
Probe : CB3_FCC_30-1G(2007) - VERTICAL	Power : AC 120V/60Hz
EUT : WIRELESS G ADSL2+ MODEM ROUTER	Note : Mode 3: Transmit (D-Link)-G (DC)

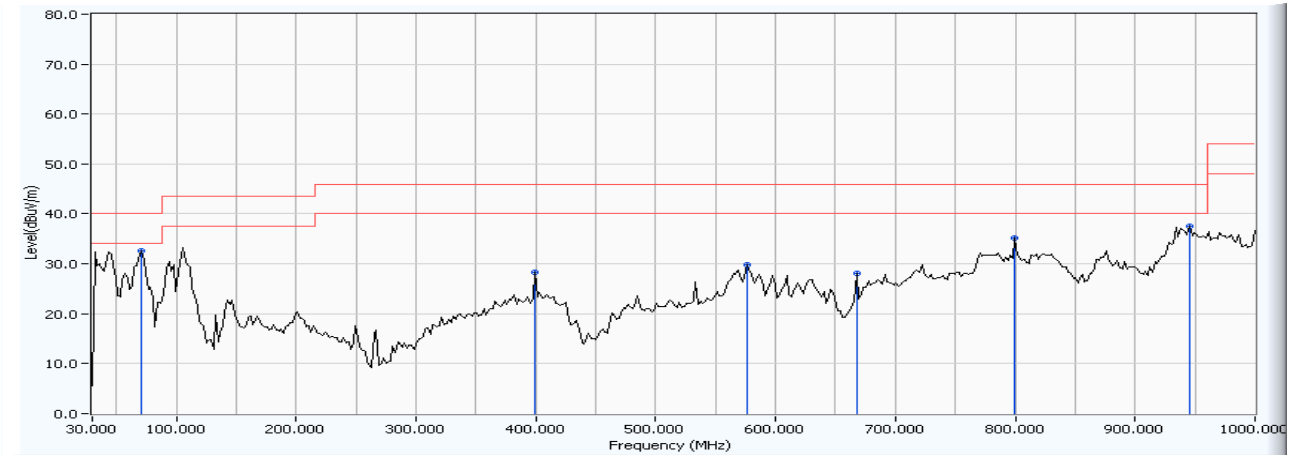

		Frequency (MHz)	Correct Factor (dB)	Reading Level (dBuV)	Measure Level (dBuV/m)	Margin (dB)	Limit (dBuV/m)	Detector Type
1	*	70.822	-6.521	39.085	32.564	-7.436	40.000	QUASI-PEAK
2		399.339	3.575	24.758	28.333	-17.667	46.000	QUASI-PEAK
3		576.232	8.343	21.396	29.739	-16.261	46.000	QUASI-PEAK
4		667.595	2.373	25.738	28.111	-17.889	46.000	QUASI-PEAK
5		799.780	10.822	24.312	35.134	-10.866	46.000	QUASI-PEAK
6		945.571	15.267	22.296	37.563	-8.437	46.000	QUASI-PEAK

Note:

1. All Reading Levels are Quasi-Peak value.
2. “ * ”, means this data is the worst emission level.
3. Measurement Level = Reading Level + Correct Factor.

Site : Site 2	Time : 2008/06/19 - 21:22
Limit : FCC_CLASS_B_03M_QP	Margin : 6
Probe : CB3_FCC_30-1G(2007) - HORIZONTAL	Power : AC 120V/60Hz
EUT : WIRELESS G ADSL2+ MODEM ROUTER	Note : Mode 3: Transmit (D-Link)-N-20M(DC)

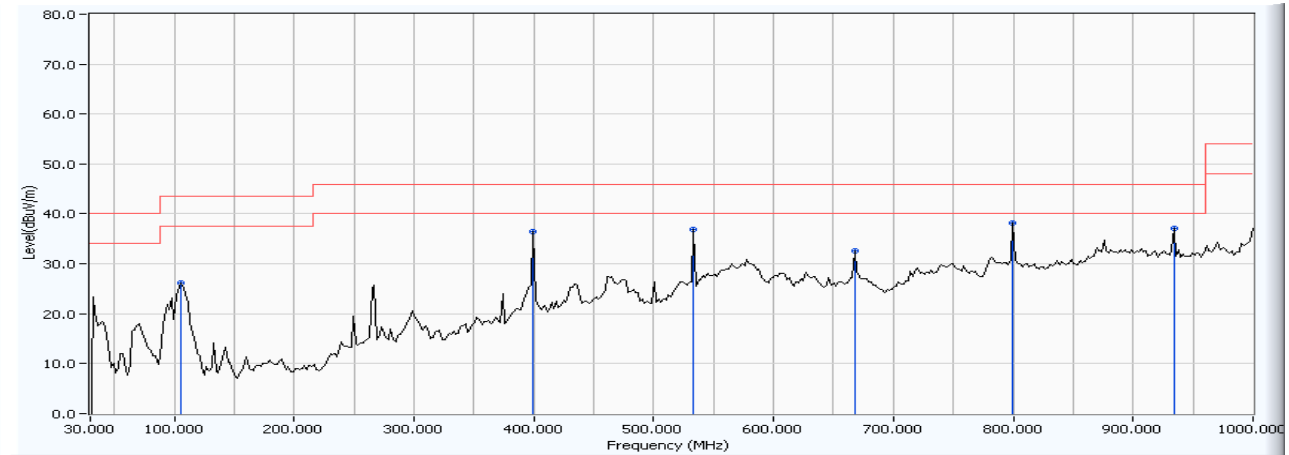

	Frequency (MHz)	Correct Factor (dB)	Reading Level (dBuV)	Measure Level (dBuV/m)	Margin (dB)	Limit (dBuV/m)	Detector Type
1	105.812	-6.398	32.646	26.248	-17.252	43.500	QUASI-PEAK
2	399.339	5.189	31.379	36.568	-9.432	46.000	QUASI-PEAK
3	533.467	5.528	31.296	36.824	-9.176	46.000	QUASI-PEAK
4	667.595	6.963	25.741	32.704	-13.296	46.000	QUASI-PEAK
5	* 799.780	9.412	28.756	38.168	-7.832	46.000	QUASI-PEAK
6	933.908	10.692	26.358	37.049	-8.951	46.000	QUASI-PEAK

Note:

1. All Reading Levels are Quasi-Peak value.
2. “ * ”, means this data is the worst emission level.
3. Measurement Level = Reading Level + Correct Factor.

Site : Site 2	Time : 2008/06/19 - 21:26
Limit : FCC_CLASS_B_03M_QP	Margin : 6
Probe : CB3_FCC_30-1G(2007) - VERTICAL	Power : AC 120V/60Hz
EUT : WIRELESS G ADSL2+ MODEM ROUTER	Note : Mode 3: Transmit (D-Link)-N-20M(DC)

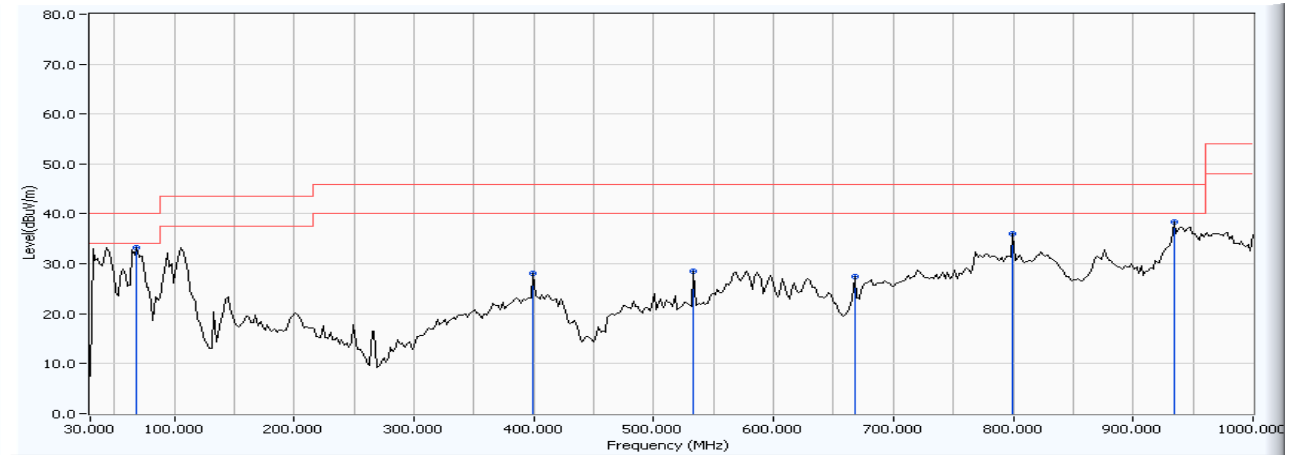

		Frequency (MHz)	Correct Factor (dB)	Reading Level (dBuV)	Measure Level (dBuV/m)	Margin (dB)	Limit (dBuV/m)	Detector Type
1	*	68.878	-6.279	39.466	33.186	-6.814	40.000	QUASI-PEAK
2		399.339	3.575	24.505	28.080	-17.920	46.000	QUASI-PEAK
3		533.467	1.403	27.157	28.561	-17.439	46.000	QUASI-PEAK
4		667.595	2.373	25.168	27.541	-18.459	46.000	QUASI-PEAK
5		799.780	10.822	25.305	36.127	-9.873	46.000	QUASI-PEAK
6		933.908	14.040	24.452	38.492	-7.508	46.000	QUASI-PEAK

Note:

1. All Reading Levels are Quasi-Peak value.
2. “ * ”, means this data is the worst emission level.
3. Measurement Level = Reading Level + Correct Factor.

Site : Site 2	Time : 2008/06/19 - 21:31
Limit : FCC_CLASS_B_03M_QP	Margin : 6
Probe : CB3_FCC_30-1G(2007) - HORIZONTAL	Power : AC 120V/60Hz
EUT : WIRELESS G ADSL2+ MODEM ROUTER	Note : Mode 3: Transmit (D-Link)-N-40M(DC)

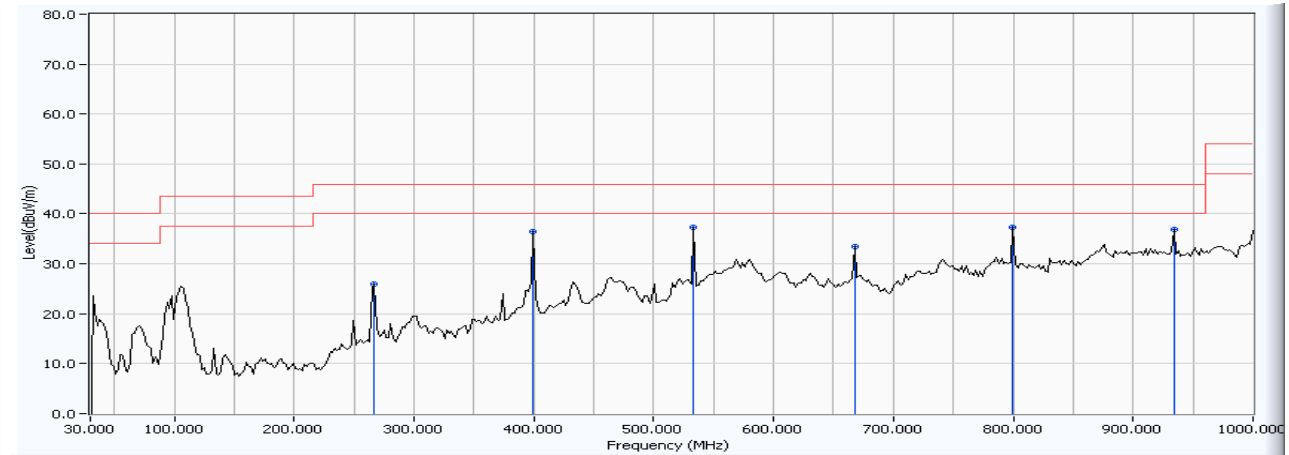

	Frequency (MHz)	Correct Factor (dB)	Reading Level (dBuV)	Measure Level (dBuV/m)	Margin (dB)	Limit (dBuV/m)	Detector Type
1	267.154	-3.955	29.999	26.043	-19.957	46.000	QUASI-PEAK
2	399.339	5.189	31.253	36.442	-9.558	46.000	QUASI-PEAK
3	* 533.467	5.528	31.790	37.318	-8.682	46.000	QUASI-PEAK
4	667.595	6.963	26.541	33.504	-12.496	46.000	QUASI-PEAK
5	799.780	9.412	27.873	37.285	-8.715	46.000	QUASI-PEAK
6	933.908	10.692	26.283	36.974	-9.026	46.000	QUASI-PEAK

Note:

1. All Reading Levels are Quasi-Peak value.
2. “ * ”, means this data is the worst emission level.
3. Measurement Level = Reading Level + Correct Factor.

Site : Site 2	Time : 2008/06/19 - 21:35
Limit : FCC_CLASS_B_03M_QP	Margin : 6
Probe : CB3_FCC_30-1G(2007) - VERTICAL	Power : AC 120V/60Hz
EUT : WIRELESS G ADSL2+ MODEM ROUTER	Note : Mode 3: Transmit (D-Link)-N-40M(DC)

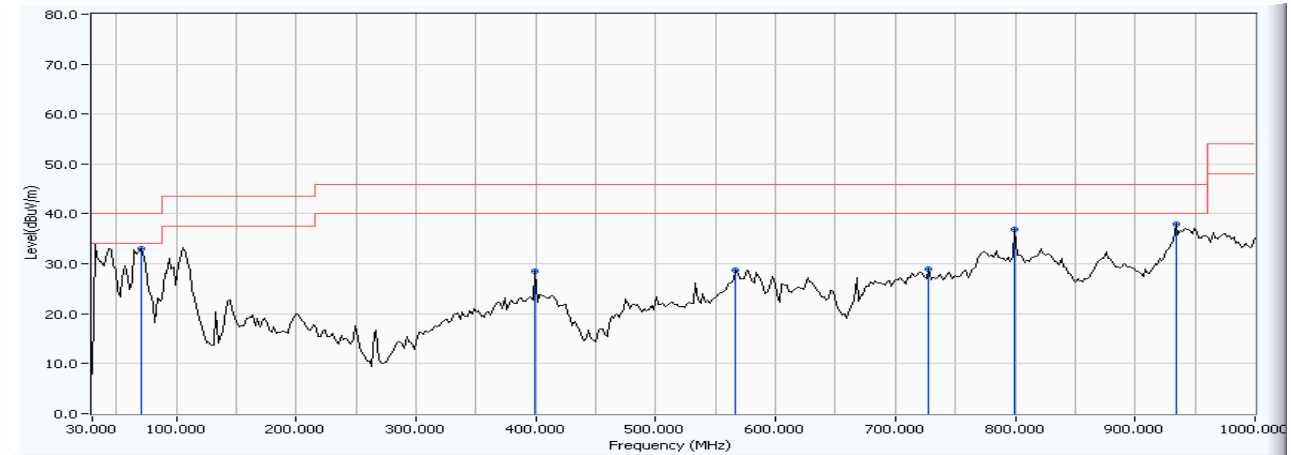

		Frequency (MHz)	Correct Factor (dB)	Reading Level (dBuV)	Measure Level (dBuV/m)	Margin (dB)	Limit (dBuV/m)	Detector Type
1	*	70.822	-6.521	39.529	33.008	-6.992	40.000	QUASI-PEAK
2		399.339	3.575	24.926	28.501	-17.499	46.000	QUASI-PEAK
3		566.513	8.033	20.690	28.723	-17.277	46.000	QUASI-PEAK
4		727.856	7.582	21.465	29.047	-16.953	46.000	QUASI-PEAK
5		799.780	10.822	26.108	36.930	-9.070	46.000	QUASI-PEAK
6		933.908	14.040	23.924	37.964	-8.036	46.000	QUASI-PEAK

Note:

1. All Reading Levels are Quasi-Peak value.
2. “ * ”, means this data is the worst emission level.
3. Measurement Level = Reading Level + Correct Factor.

Harmonic & Spurious:

Site : Site 2	Time : 2008/06/17 - 20:23
Limit : FCC_SpartC_15.247_H_03M_PK	Margin : 6
Probe : CB4_FCC_1-18G(2008-05) - HORIZONTAL	Power : AC 120V/60Hz
EUT : WIRELESS G ADSL2+ MODEM ROUTER	Note : TX-B-CH1

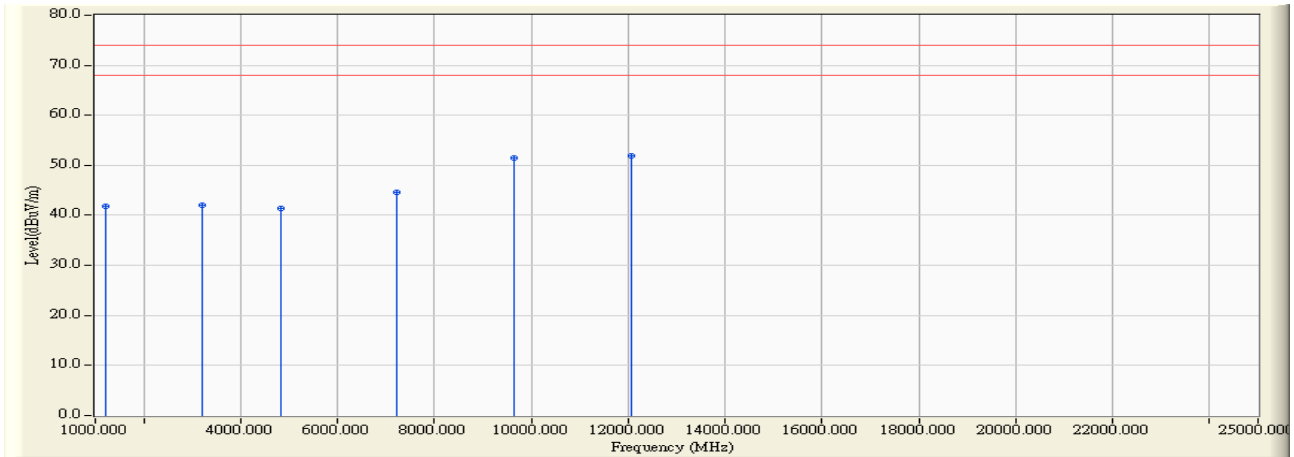

	Frequency (MHz)	Correct Factor (dB)	Reading Level (dBuV)	Measure Level (dBuV/m)	Margin (dB)	Limit (dBuV/m)	Detector Type	Ant Pos (cm)	Table Pos (deg)
1	1199.830	-8.032	49.880	41.848	-32.152	74.000	PEAK	0.000	0.000
2	3215.870	-1.959	44.040	42.081	-31.919	74.000	PEAK	0.000	0.000
3	4824.100	3.126	38.270	41.396	-32.604	74.000	PEAK	0.000	0.000
4	7235.700	6.969	37.670	44.639	-29.361	74.000	PEAK	0.000	0.000
5	9648.300	15.111	36.410	51.521	-22.479	74.000	PEAK	0.000	0.000
6	* 12060.400	16.825	35.180	52.006	-21.994	74.000	PEAK	0.000	0.000

Note:

1. All readings above 1GHz are performed with peak and/or average measurements as necessary.
2. Peak measurements: RBW = 1MHz, VBW = 3 MHz, Sweep: Auto.
3. Average measurements: RBW = 1MHz, VBW = 10 Hz, Sweep: Auto.
4. " * ", means this data is the worst emission level.
5. Measurement Level = Reading Level + Correct Factor.
6. The average measurement was not performed when the peak measured data under the limit of average detection.

Site : Site 2	Time : 2008/06/17 - 20:34
Limit : FCC_SpartC_15.247_H_03M_PK	Margin : 6
Probe : CB4_FCC_1-18G(2008-05) - VERTICAL	Power : AC 120V/60Hz
EUT : WIRELESS G ADSL2+ MODEM ROUTER	Note : TX-B-CH1

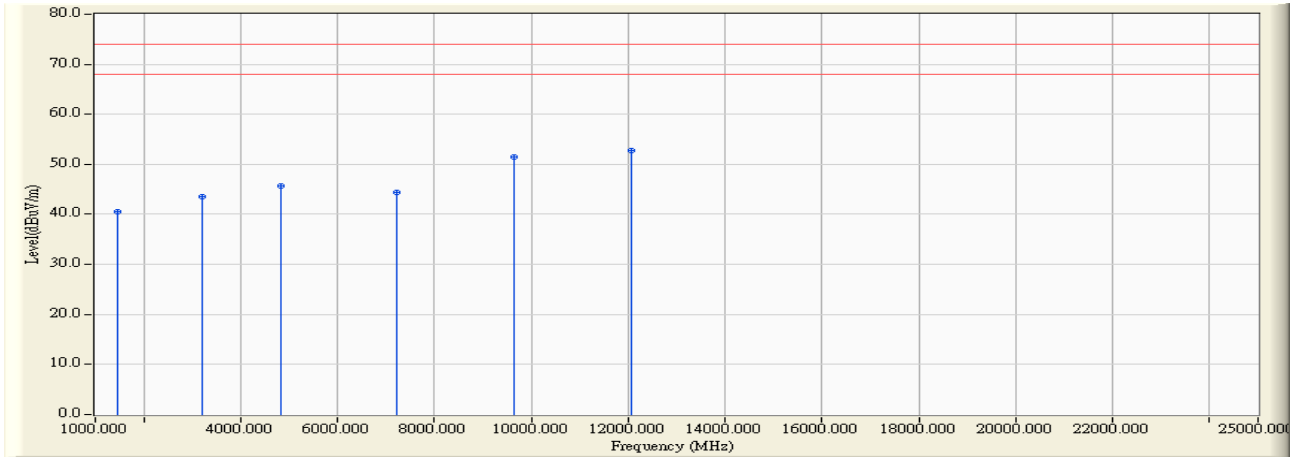

	Frequency (MHz)	Correct Factor (dB)	Reading Level (dBuV)	Measure Level (dBuV/m)	Margin (dB)	Limit (dBuV/m)	Detector Type	Ant Pos (cm)	Table Pos (deg)
1	1466.700	-7.027	47.640	40.613	-33.387	74.000	PEAK	0.000	0.000
2	3215.700	-1.959	45.410	43.451	-30.549	74.000	PEAK	0.000	0.000
3	4824.300	3.128	42.620	45.747	-28.253	74.000	PEAK	0.000	0.000
4	7235.400	7.440	37.000	44.440	-29.560	74.000	PEAK	0.000	0.000
5	9648.100	13.812	37.700	51.512	-22.488	74.000	PEAK	0.000	0.000
6	* 12060.200	16.707	35.990	52.697	-21.303	74.000	PEAK	0.000	0.000

Note:

1. All readings above 1GHz are performed with peak and/or average measurements as necessary.
2. Peak measurements: RBW = 1MHz, VBW = 3 MHz, Sweep: Auto.
3. Average measurements: RBW = 1MHz, VBW = 10 Hz, Sweep: Auto.
4. " * ", means this data is the worst emission level.
5. Measurement Level = Reading Level + Correct Factor.
6. The average measurement was not performed when the peak measured data under the limit of average detection.

Site : Site 2	Time : 2008/06/17 - 20:55
Limit : FCC_SpartC_15.247_H_03M_PK	Margin : 6
Probe : CB4_FCC_1-18G(2008-05) - HORIZONTAL	Power : AC 120V/60Hz
EUT : WIRELESS G ADSL2+ MODEM ROUTER	Note : TX-B-CH6

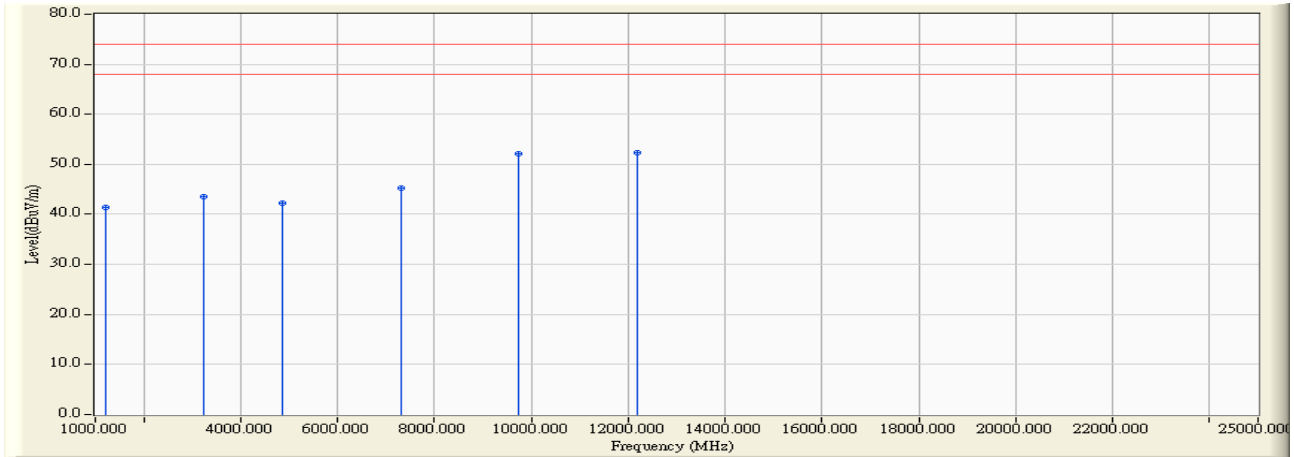

	Frequency (MHz)	Correct Factor (dB)	Reading Level (dBuV)	Measure Level (dBuV/m)	Margin (dB)	Limit (dBuV/m)	Detector Type	Ant Pos (cm)	Table Pos (deg)
1	1200.010	-8.031	49.490	41.459	-32.541	74.000	PEAK	0.000	0.000
2	3249.320	-1.898	45.390	43.493	-30.507	74.000	PEAK	0.000	0.000
3	4874.400	3.283	38.930	42.213	-31.787	74.000	PEAK	0.000	0.000
4	7311.000	7.017	38.240	45.257	-28.743	74.000	PEAK	0.000	0.000
5	9748.200	13.951	38.088	52.039	-21.961	74.000	PEAK	0.000	0.000
6	* 12184.800	16.835	35.508	52.342	-21.658	74.000	PEAK	0.000	0.000

Note:

1. All readings above 1GHz are performed with peak and/or average measurements as necessary.
2. Peak measurements: RBW = 1MHz, VBW = 3 MHz, Sweep: Auto.
3. Average measurements: RBW = 1MHz, VBW = 10 Hz, Sweep: Auto.
4. " * ", means this data is the worst emission level.
5. Measurement Level = Reading Level + Correct Factor.
6. The average measurement was not performed when the peak measured data under the limit of average detection.

Site : Site 2	Time : 2008/06/17 - 21:07
Limit : FCC_SpartC_15.247_H_03M_PK	Margin : 6
Probe : CB4_FCC_1-18G(2008-05) - VERTICAL	Power : AC 120V/60Hz
EUT : WIRELESS G ADSL2+ MODEM ROUTER	Note : TX-B-CH6

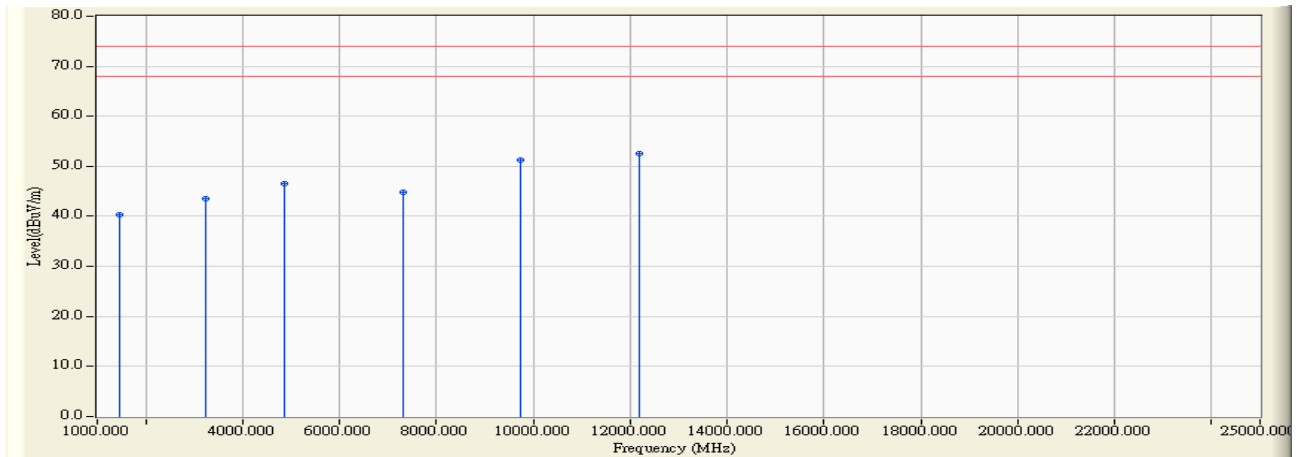

	Frequency (MHz)	Correct Factor (dB)	Reading Level (dBuV)	Measure Level (dBuV/m)	Margin (dB)	Limit (dBuV/m)	Detector Type	Ant Pos (cm)	Table Pos (deg)
1	1466.340	-7.029	47.260	40.231	-33.769	74.000	PEAK	0.000	0.000
2	3249.050	-1.898	45.340	43.442	-30.558	74.000	PEAK	0.000	0.000
3	4874.800	3.285	43.320	46.605	-27.395	74.000	PEAK	0.000	0.000
4	7311.120	7.637	37.150	44.787	-29.213	74.000	PEAK	0.000	0.000
5	9748.000	13.951	37.370	51.321	-22.679	74.000	PEAK	0.000	0.000
6	* 12184.600	16.833	35.780	52.614	-21.386	74.000	PEAK	0.000	0.000

Note:

1. All readings above 1GHz are performed with peak and/or average measurements as necessary.
2. Peak measurements: RBW = 1MHz, VBW = 3 MHz, Sweep: Auto.
3. Average measurements: RBW = 1MHz, VBW = 10 Hz, Sweep: Auto.
4. " * ", means this data is the worst emission level.
5. Measurement Level = Reading Level + Correct Factor.
6. The average measurement was not performed when the peak measured data under the limit of average detection.

Site : Site 2	Time : 2008/06/17 - 21:20
Limit : FCC_SpartC_15.247_H_03M_PK	Margin : 6
Probe : CB4_FCC_1-18G(2008-05) - HORIZONTAL	Power : AC 120V/60Hz
EUT : WIRELESS G ADSL2+ MODEM ROUTER	Note : TX-B-CH11

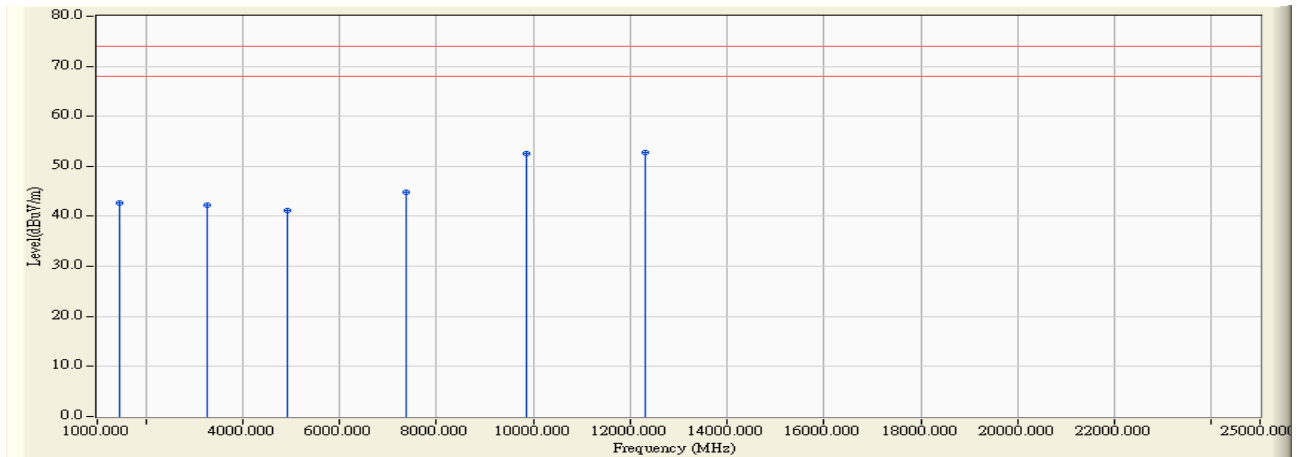

	Frequency (MHz)	Correct Factor (dB)	Reading Level (dBuV)	Measure Level (dBuV/m)	Margin (dB)	Limit (dBuV/m)	Detector Type	Ant Pos (cm)	Table Pos (deg)
1	1466.640	-7.028	49.740	42.712	-31.288	74.000	PEAK	0.000	0.000
2	3282.560	-1.820	44.130	42.311	-31.689	74.000	PEAK	0.000	0.000
3	4924.100	3.438	37.780	41.218	-32.782	74.000	PEAK	0.000	0.000
4	7385.300	7.084	37.680	44.764	-29.236	74.000	PEAK	0.000	0.000
5	9847.500	15.767	36.830	52.597	-21.403	74.000	PEAK	0.000	0.000
6	* 12309.700	17.585	35.190	52.774	-21.226	74.000	PEAK	0.000	0.000

Note:

1. All readings above 1GHz are performed with peak and/or average measurements as necessary.
2. Peak measurements: RBW = 1MHz, VBW = 3 MHz, Sweep: Auto.
3. Average measurements: RBW = 1MHz, VBW = 10 Hz, Sweep: Auto.
4. " * ", means this data is the worst emission level.
5. Measurement Level = Reading Level + Correct Factor.
6. The average measurement was not performed when the peak measured data under the limit of average detection.

Site : Site 2	Time : 2008/06/17 - 21:28
Limit : FCC_SpartC_15.247_H_03M_PK	Margin : 6
Probe : CB4_FCC_1-18G(2008-05) - VERTICAL	Power : AC 120V/60Hz
EUT : WIRELESS G ADSL2+ MODEM ROUTER	Note : TX-B-CH11

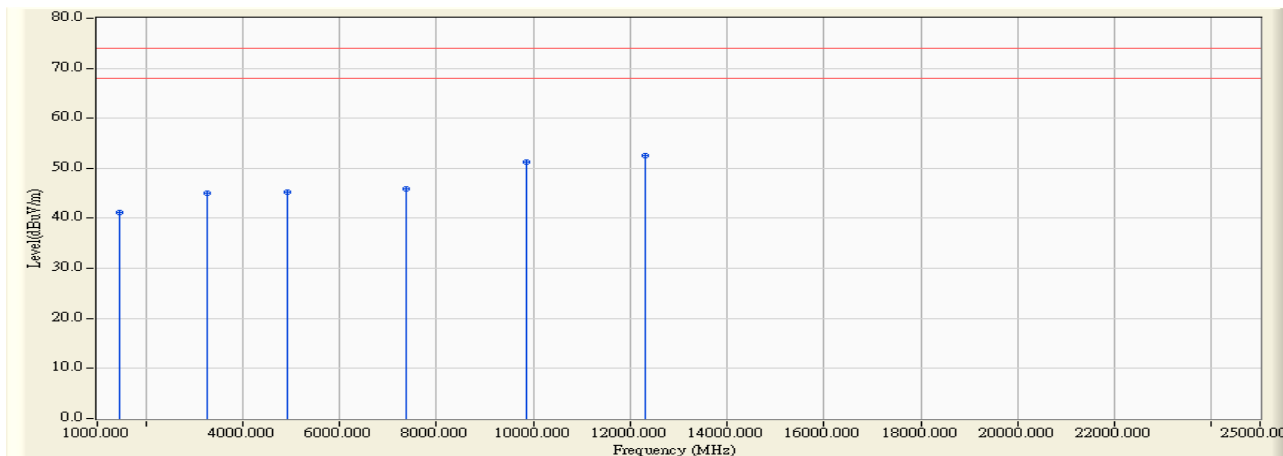

	Frequency (MHz)	Correct Factor (dB)	Reading Level (dBuV)	Measure Level (dBuV/m)	Margin (dB)	Limit (dBuV/m)	Detector Type	Ant Pos (cm)	Table Pos (deg)
1	1466.350	-7.029	48.190	41.161	-32.839	74.000	PEAK	0.000	0.000
2	3282.420	-1.820	46.950	45.131	-28.869	74.000	PEAK	0.000	0.000
3	4924.200	3.438	41.840	45.278	-28.722	74.000	PEAK	0.000	0.000
4	7385.100	7.851	38.060	45.911	-28.089	74.000	PEAK	0.000	0.000
5	9847.400	14.074	37.170	51.244	-22.756	74.000	PEAK	0.000	0.000
6	* 12309.700	16.967	35.550	52.516	-21.484	74.000	PEAK	0.000	0.000

Note:

1. All readings above 1GHz are performed with peak and/or average measurements as necessary.
2. Peak measurements: RBW = 1MHz, VBW = 3 MHz, Sweep: Auto.
3. Average measurements: RBW = 1MHz, VBW = 10 Hz, Sweep: Auto.
4. " * ", means this data is the worst emission level.
5. Measurement Level = Reading Level + Correct Factor.
6. The average measurement was not performed when the peak measured data under the limit of average detection.

Site : Site 2	Time : 2008/06/17 - 21:41
Limit : FCC_SpartC_15.247_H_03M_PK	Margin : 6
Probe : CB4_FCC_1-18G(2008-05) - HORIZONTAL	Power : AC 120V/60Hz
EUT : WIRELESS G ADSL2+ MODEM ROUTER	Note : TX-G-CH1

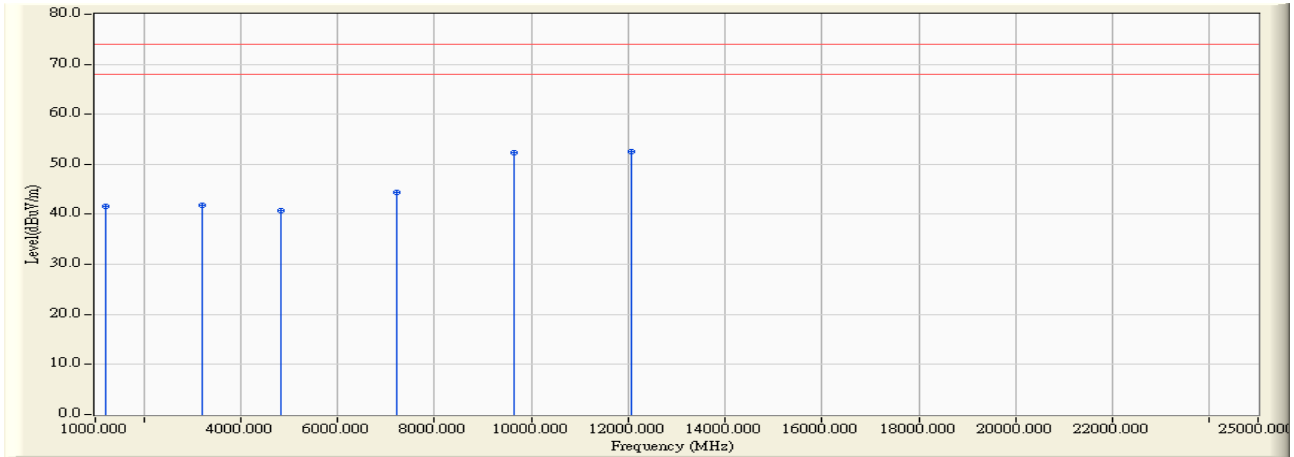

	Frequency (MHz)	Correct Factor (dB)	Reading Level (dBuV)	Measure Level (dBuV/m)	Margin (dB)	Limit (dBuV/m)	Detector Type	Ant Pos (cm)	Table Pos (deg)
1	1200.100	-8.031	49.730	41.699	-32.301	74.000	PEAK	0.000	0.000
2	3215.920	-1.958	43.880	41.922	-32.078	74.000	PEAK	0.000	0.000
3	4822.100	3.119	37.660	40.779	-33.221	74.000	PEAK	0.000	0.000
4	7235.100	6.968	37.500	44.468	-29.532	74.000	PEAK	0.000	0.000
5	9646.800	15.105	37.280	52.385	-21.615	74.000	PEAK	0.000	0.000
6	* 12059.800	16.825	35.700	52.524	-21.476	74.000	PEAK	0.000	0.000

Note:

1. All readings above 1GHz are performed with peak and/or average measurements as necessary.
2. Peak measurements: RBW = 1MHz, VBW = 3 MHz, Sweep: Auto.
3. Average measurements: RBW = 1MHz, VBW = 10 Hz, Sweep: Auto.
4. " * ", means this data is the worst emission level.
5. Measurement Level = Reading Level + Correct Factor.
6. The average measurement was not performed when the peak measured data under the limit of average detection.

Site : Site 2	Time : 2008/06/17 - 21:49
Limit : FCC_SpartC_15.247_H_03M_PK	Margin : 6
Probe : CB4_FCC_1-18G(2008-05) - VERTICAL	Power : AC 120V/60Hz
EUT : WIRELESS G ADSL2+ MODEM ROUTER	Note : TX-G-CH1

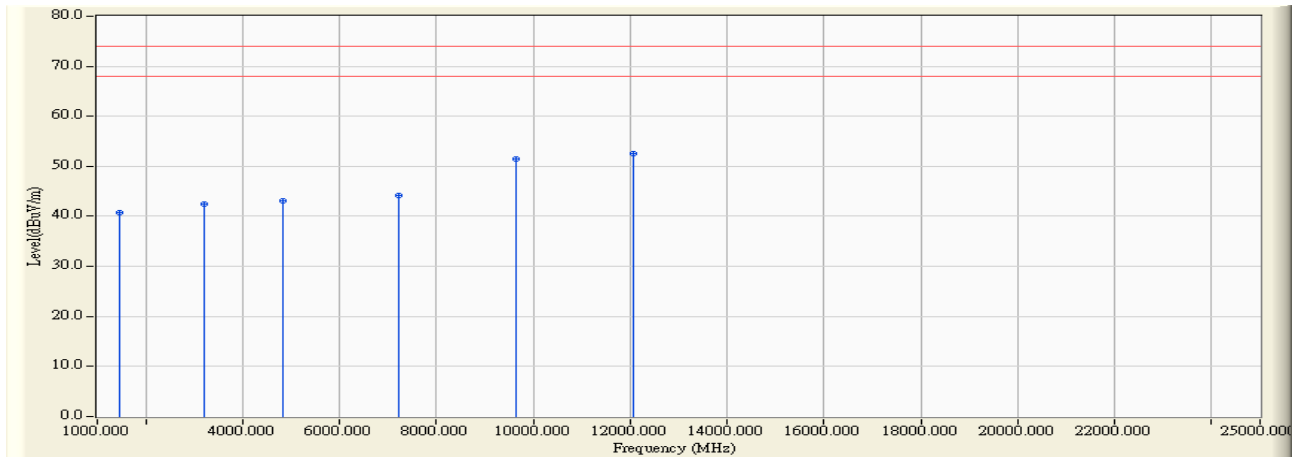

	Frequency (MHz)	Correct Factor (dB)	Reading Level (dBuV)	Measure Level (dBuV/m)	Margin (dB)	Limit (dBuV/m)	Detector Type	Ant Pos (cm)	Table Pos (deg)
1	1466.740	-7.027	47.730	40.703	-33.297	74.000	PEAK	0.000	0.000
2	3215.850	-1.959	44.480	42.521	-31.479	74.000	PEAK	0.000	0.000
3	4822.570	3.121	39.950	43.071	-30.929	74.000	PEAK	0.000	0.000
4	7235.240	7.440	36.710	44.150	-29.850	74.000	PEAK	0.000	0.000
5	9646.500	13.810	37.710	51.520	-22.480	74.000	PEAK	0.000	0.000
6	* 12059.600	16.707	35.890	52.597	-21.403	74.000	PEAK	0.000	0.000

Note:

1. All readings above 1GHz are performed with peak and/or average measurements as necessary.
2. Peak measurements: RBW = 1MHz, VBW = 3 MHz, Sweep: Auto.
3. Average measurements: RBW = 1MHz, VBW = 10 Hz, Sweep: Auto.
4. " * ", means this data is the worst emission level.
5. Measurement Level = Reading Level + Correct Factor.
6. The average measurement was not performed when the peak measured data under the limit of average detection.

Site : Site 2	Time : 2008/06/17 - 22:08
Limit : FCC_SpartC_15.247_H_03M_PK	Margin : 6
Probe : CB4_FCC_1-18G(2008-05) - HORIZONTAL	Power : AC 120V/60Hz
EUT : WIRELESS G ADSL2+ MODEM ROUTER	Note : TX-G-CH6

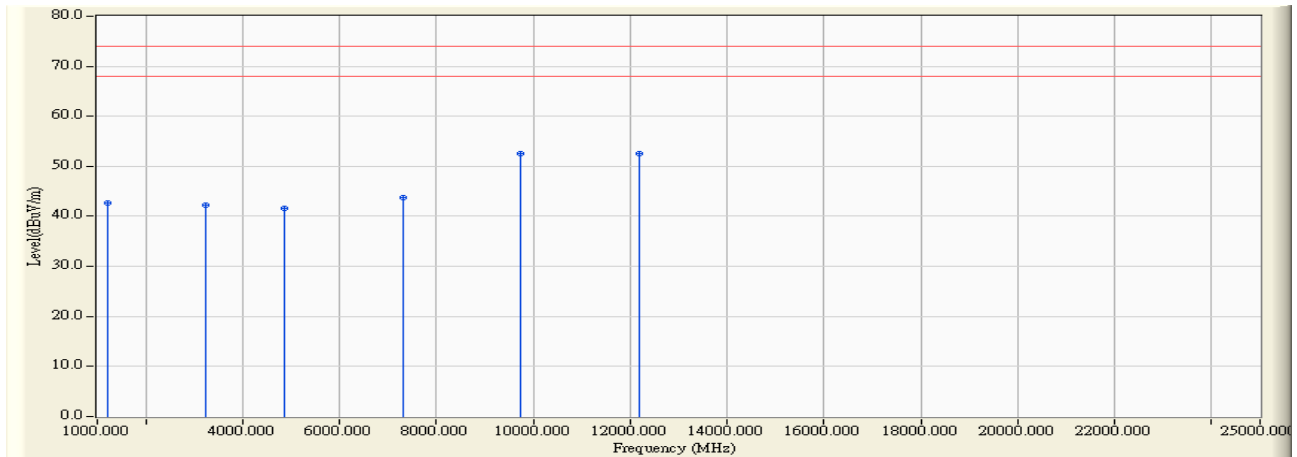

	Frequency (MHz)	Correct Factor (dB)	Reading Level (dBuV)	Measure Level (dBuV/m)	Margin (dB)	Limit (dBuV/m)	Detector Type	Ant Pos (cm)	Table Pos (deg)
1	1199.980	-8.032	50.740	42.709	-31.291	74.000	PEAK	0.000	0.000
2	3249.540	-1.896	44.150	42.253	-31.747	74.000	PEAK	0.000	0.000
3	4873.800	3.281	38.250	41.531	-32.469	74.000	PEAK	0.000	0.000
4	7310.200	7.017	36.720	43.737	-30.263	74.000	PEAK	0.000	0.000
5	* 9749.000	15.452	37.130	52.582	-21.418	74.000	PEAK	0.000	0.000
6	12184.700	17.201	35.290	52.492	-21.508	74.000	PEAK	0.000	0.000

Note:

1. All readings above 1GHz are performed with peak and/or average measurements as necessary.
2. Peak measurements: RBW = 1MHz, VBW = 3 MHz, Sweep: Auto.
3. Average measurements: RBW = 1MHz, VBW = 10 Hz, Sweep: Auto.
4. " * ", means this data is the worst emission level.
5. Measurement Level = Reading Level + Correct Factor.
6. The average measurement was not performed when the peak measured data under the limit of average detection.

Site : Site 2	Time : 2008/06/17 - 22:23
Limit : FCC_SpartC_15.247_H_03M_PK	Margin : 6
Probe : CB4_FCC_1-18G(2008-05) - VERTICAL	Power : AC 120V/60Hz
EUT : WIRELESS G ADSL2+ MODEM ROUTER	Note : TX-G-CH6

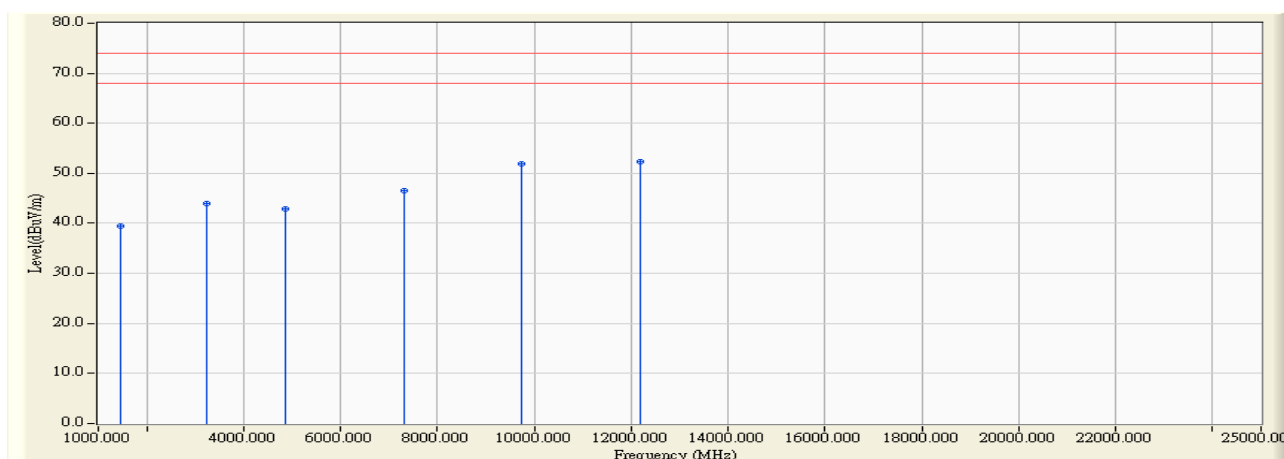

	Frequency (MHz)	Correct Factor (dB)	Reading Level (dBuV)	Measure Level (dBuV/m)	Margin (dB)	Limit (dBuV/m)	Detector Type	Ant Pos (cm)	Table Pos (deg)
1	1466.570	-7.028	46.520	39.492	-34.508	74.000	PEAK	0.000	0.000
2	3249.450	-1.897	45.950	44.053	-29.947	74.000	PEAK	0.000	0.000
3	4873.600	3.281	39.520	42.801	-31.199	74.000	PEAK	0.000	0.000
4	7310.100	7.634	38.830	46.464	-27.536	74.000	PEAK	0.000	0.000
5	9748.860	13.952	37.930	51.882	-22.118	74.000	PEAK	0.000	0.000
6	* 12184.300	16.834	35.600	52.434	-21.566	74.000	PEAK	0.000	0.000

Note:

1. All readings above 1GHz are performed with peak and/or average measurements as necessary.
2. Peak measurements: RBW = 1MHz, VBW = 3 MHz, Sweep: Auto.
3. Average measurements: RBW = 1MHz, VBW = 10 Hz, Sweep: Auto.
4. " * ", means this data is the worst emission level.
5. Measurement Level = Reading Level + Correct Factor.
6. The average measurement was not performed when the peak measured data under the limit of average detection.

Site : Site 2	Time : 2008/06/17 - 23:01
Limit : FCC_SpartC_15.247_H_03M_PK	Margin : 6
Probe : CB4_FCC_1-18G(2008-05) - HORIZONTAL	Power : AC 120V/60Hz
EUT : WIRELESS G ADSL2+ MODEM ROUTER	Note : TX-G-CH11

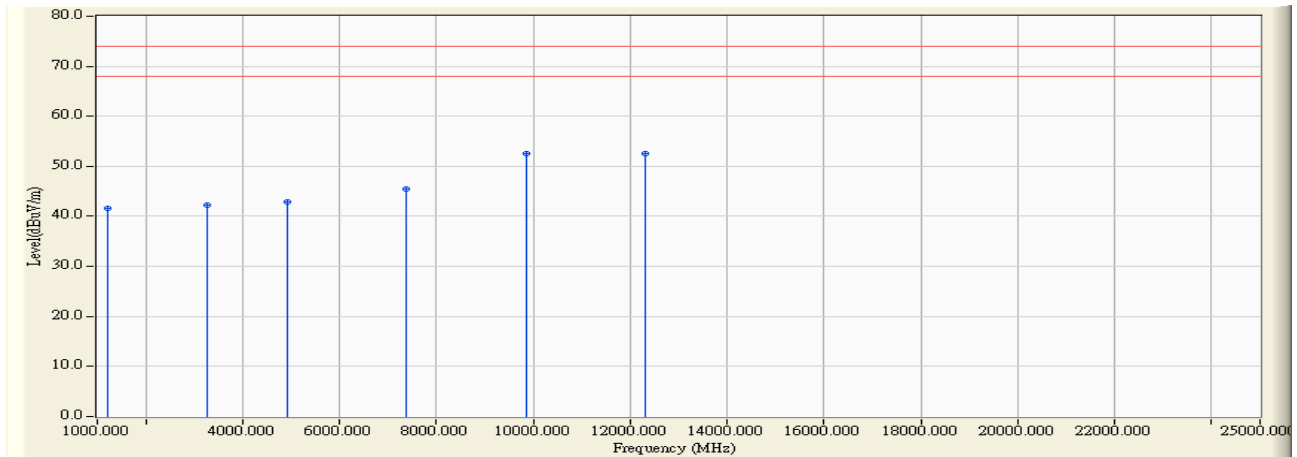

	Frequency (MHz)	Correct Factor (dB)	Reading Level (dBuV)	Measure Level (dBuV/m)	Margin (dB)	Limit (dBuV/m)	Detector Type	Ant Pos (cm)	Table Pos (deg)
1	1200.100	-8.031	49.730	41.699	-32.301	74.000	PEAK	0.000	0.000
2	3282.700	-1.818	44.060	42.241	-31.759	74.000	PEAK	0.000	0.000
3	4924.200	3.438	39.520	42.958	-31.042	74.000	PEAK	0.000	0.000
4	7385.100	7.084	38.290	45.374	-28.626	74.000	PEAK	0.000	0.000
5	9847.800	15.769	36.720	52.488	-21.512	74.000	PEAK	0.000	0.000
6	* 12309.100	17.583	34.920	52.503	-21.497	74.000	PEAK	0.000	0.000

Note:

1. All readings above 1GHz are performed with peak and/or average measurements as necessary.
2. Peak measurements: RBW = 1MHz, VBW = 3 MHz, Sweep: Auto.
3. Average measurements: RBW = 1MHz, VBW = 10 Hz, Sweep: Auto.
4. " * ", means this data is the worst emission level.
5. Measurement Level = Reading Level + Correct Factor.
6. The average measurement was not performed when the peak measured data under the limit of average detection.

Site : Site 2	Time : 2008/06/17 - 23:09
Limit : FCC_SpartC_15.247_H_03M_PK	Margin : 6
Probe : CB4_FCC_1-18G(2008-05) - VERTICAL	Power : AC 120V/60Hz
EUT : WIRELESS G ADSL2+ MODEM ROUTER	Note : TX-G-CH11

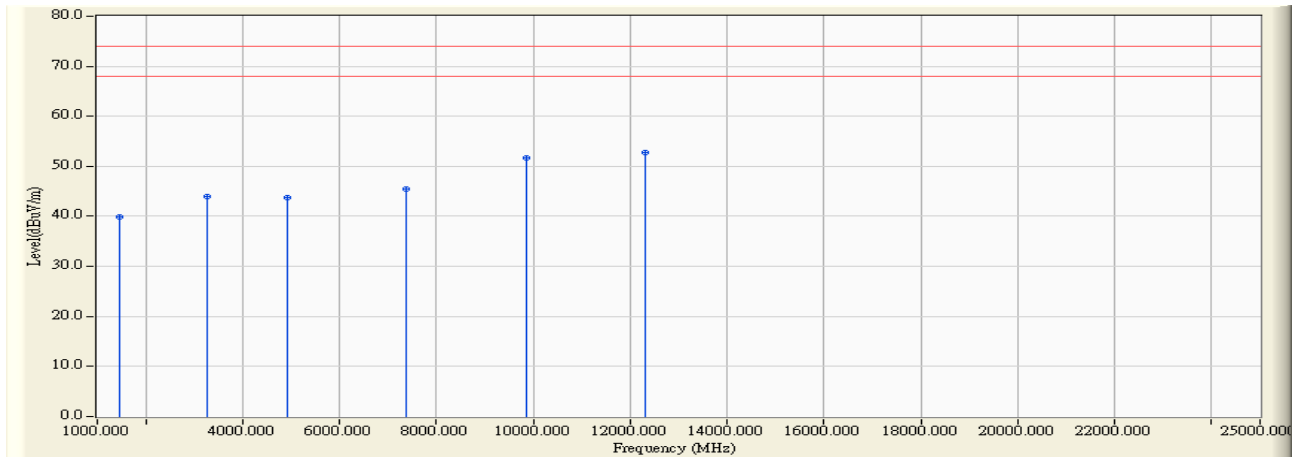

	Frequency (MHz)	Correct Factor (dB)	Reading Level (dBuV)	Measure Level (dBuV/m)	Margin (dB)	Limit (dBuV/m)	Detector Type	Ant Pos (cm)	Table Pos (deg)
1	1466.580	-7.028	46.870	39.842	-34.158	74.000	PEAK	0.000	0.000
2	3282.600	-1.820	45.870	44.051	-29.949	74.000	PEAK	0.000	0.000
3	4924.000	3.437	40.230	43.667	-30.333	74.000	PEAK	0.000	0.000
4	7384.900	7.851	37.650	45.501	-28.499	74.000	PEAK	0.000	0.000
5	9847.600	14.074	37.690	51.764	-22.236	74.000	PEAK	0.000	0.000
6	* 12309.400	16.965	35.700	52.666	-21.334	74.000	PEAK	0.000	0.000

Note:

1. All readings above 1GHz are performed with peak and/or average measurements as necessary.
2. Peak measurements: RBW = 1MHz, VBW = 3 MHz, Sweep: Auto.
3. Average measurements: RBW = 1MHz, VBW = 10 Hz, Sweep: Auto.
4. " * ", means this data is the worst emission level.
5. Measurement Level = Reading Level + Correct Factor.
6. The average measurement was not performed when the peak measured data under the limit of average detection.

Site : Site 2	Time : 2008/06/18 - 14:09
Limit : FCC_SpartC_15.247_H_03M_PK	Margin : 6
Probe : CB4_FCC_1-18G(2008-05) - HORIZONTAL	Power : AC 120V/60Hz
EUT : WIRELESS G ADSL2+ MODEM ROUTER	Note : TX-N(20MHz)-CH1

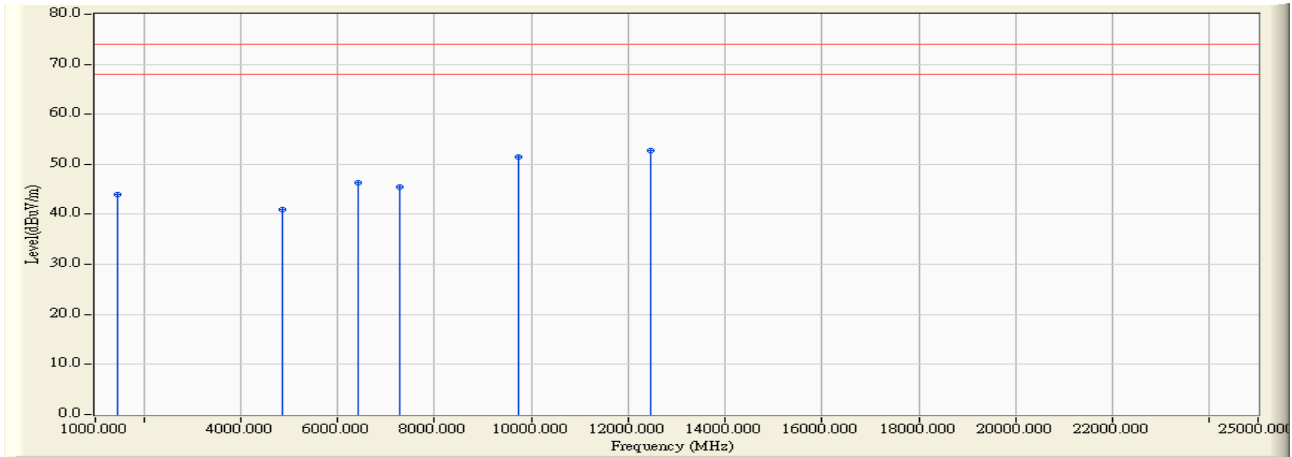

	Frequency (MHz)	Correct Factor (dB)	Reading Level (dBuV)	Measure Level (dBuV/m)	Margin (dB)	Limit (dBuV/m)	Detector Type	Ant Pos (cm)	Table Pos (deg)
1	1466.000	-7.031	50.920	43.889	-30.111	74.000	PEAK	0.000	0.000
2	4849.120	3.199	37.680	40.880	-33.120	74.000	PEAK	0.000	0.000
3	6432.000	5.002	41.340	46.342	-27.658	74.000	PEAK	0.000	0.000
4	7280.100	6.997	38.480	45.477	-28.523	74.000	PEAK	0.000	0.000
5	9723.000	15.354	36.170	51.524	-22.476	74.000	PEAK	0.000	0.000
6	* 12459.900	18.043	34.710	52.754	-21.246	74.000	PEAK	0.000	0.000

Note:

1. All readings above 1GHz are performed with peak and/or average measurements as necessary.
2. Peak measurements: RBW = 1MHz, VBW = 3 MHz, Sweep: Auto.
3. Average measurements: RBW = 1MHz, VBW = 10 Hz, Sweep: Auto.
4. " * ", means this data is the worst emission level.
5. Measurement Level = Reading Level + Correct Factor.
6. The average measurement was not performed when the peak measured data under the limit of average detection.

Site : Site 2	Time : 2008/06/18 - 14:22
Limit : FCC_SpartC_15.247_H_03M_PK	Margin : 6
Probe : CB4_FCC_1-18G(2008-05) - VERTICAL	Power : AC 120V/60Hz
EUT : WIRELESS G ADSL2+ MODEM ROUTER	Note : TX-N(20MHz)-CH1

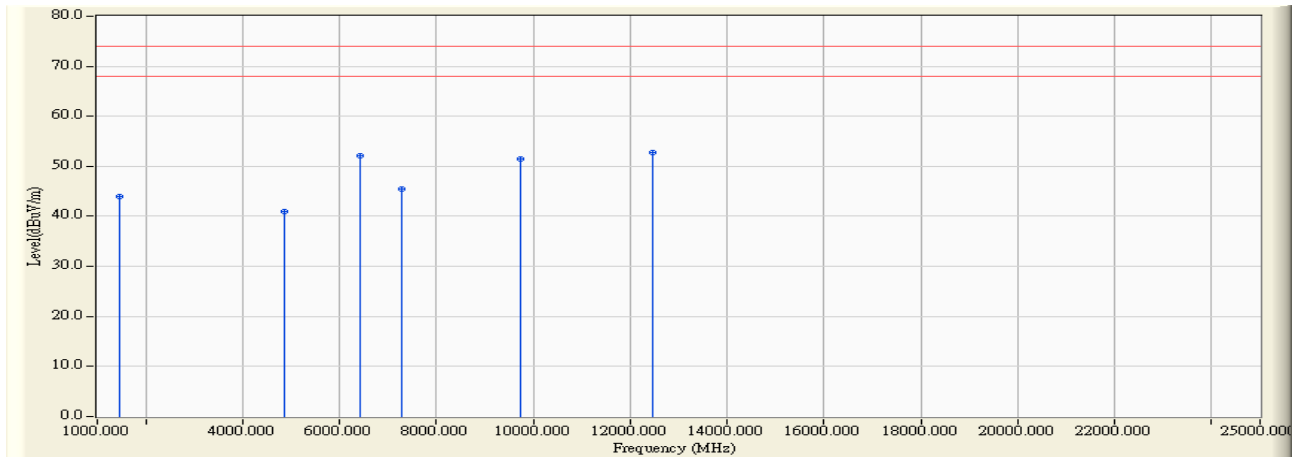

	Frequency (MHz)	Correct Factor (dB)	Reading Level (dBuV)	Measure Level (dBuV/m)	Margin (dB)	Limit (dBuV/m)	Detector Type	Ant Pos (cm)	Table Pos (deg)
1	1466.000	-7.031	50.920	43.889	-30.111	74.000	PEAK	0.000	0.000
2	4849.120	3.199	37.680	40.880	-33.120	74.000	PEAK	0.000	0.000
3	6431.960	5.002	47.030	52.032	-21.968	74.000	PEAK	0.000	0.000
4	7280.100	6.997	38.480	45.477	-28.523	74.000	PEAK	0.000	0.000
5	9723.000	15.354	36.170	51.524	-22.476	74.000	PEAK	0.000	0.000
6	* 12459.900	18.043	34.710	52.754	-21.246	74.000	PEAK	0.000	0.000

Note:

1. All readings above 1GHz are performed with peak and/or average measurements as necessary.
2. Peak measurements: RBW = 1MHz, VBW = 3 MHz, Sweep: Auto.
3. Average measurements: RBW = 1MHz, VBW = 10 Hz, Sweep: Auto.
4. " * ", means this data is the worst emission level.
5. Measurement Level = Reading Level + Correct Factor.
6. The average measurement was not performed when the peak measured data under the limit of average detection.

Site : Site 2	Time : 2008/06/18 - 15:37
Limit : FCC_SpartC_15.247_H_03M_PK	Margin : 6
Probe : CB4_FCC_1-18G(2008-05) - HORIZONTAL	Power : AC 120V/60Hz
EUT : WIRELESS G ADSL2+ MODEM ROUTER	Note : TX-N(20MHz)-CH6

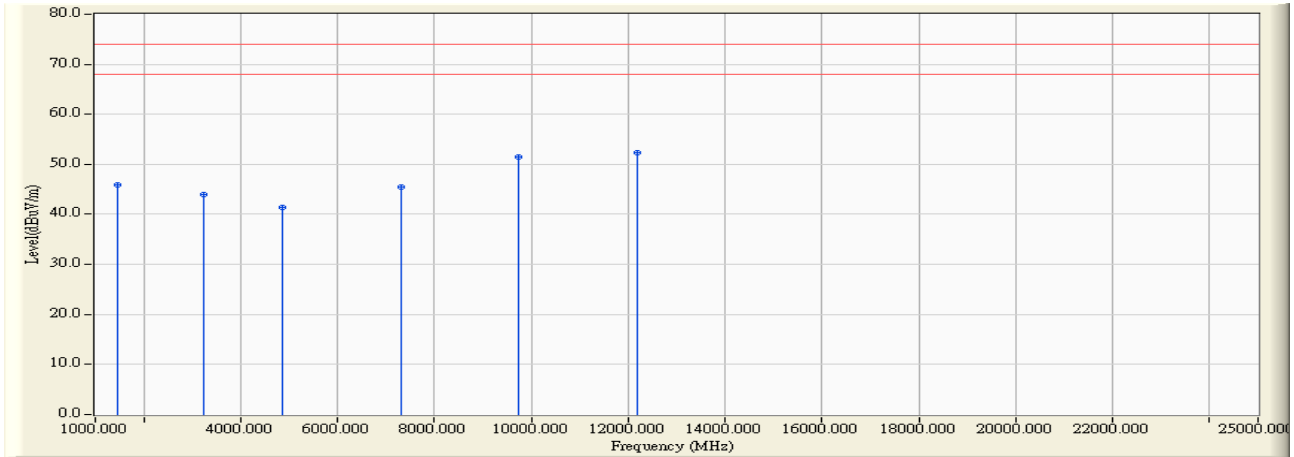

	Frequency (MHz)	Correct Factor (dB)	Reading Level (dBuV)	Measure Level (dBuV/m)	Margin (dB)	Limit (dBuV/m)	Detector Type	Ant Pos (cm)	Table Pos (deg)
1	1466.680	-7.027	53.020	45.992	-28.008	74.000	PEAK	0.000	0.000
2	3249.400	-1.898	45.960	44.063	-29.937	74.000	PEAK	0.000	0.000
3	4874.400	3.283	38.120	41.403	-32.597	74.000	PEAK	0.000	0.000
4	7311.800	7.639	37.890	45.529	-28.471	74.000	PEAK	0.000	0.000
5	9748.000	13.951	37.630	51.581	-22.419	74.000	PEAK	0.000	0.000
6	* 12184.600	16.833	35.520	52.354	-21.646	74.000	PEAK	0.000	0.000

Note:

1. All readings above 1GHz are performed with peak and/or average measurements as necessary.
2. Peak measurements: RBW = 1MHz, VBW = 3 MHz, Sweep: Auto.
3. Average measurements: RBW = 1MHz, VBW = 10 Hz, Sweep: Auto.
4. " * ", means this data is the worst emission level.
5. Measurement Level = Reading Level + Correct Factor.
6. The average measurement was not performed when the peak measured data under the limit of average detection.

Site : Site 2	Time : 2008/06/18 - 16:10
Limit : FCC_SpartC_15.247_H_03M_PK	Margin : 6
Probe : CB4_FCC_1-18G(2008-05) - VERTICAL	Power : AC 120V/60Hz
EUT : WIRELESS G ADSL2+ MODEM ROUTER	Note : TX-N(20MHz)-CH6

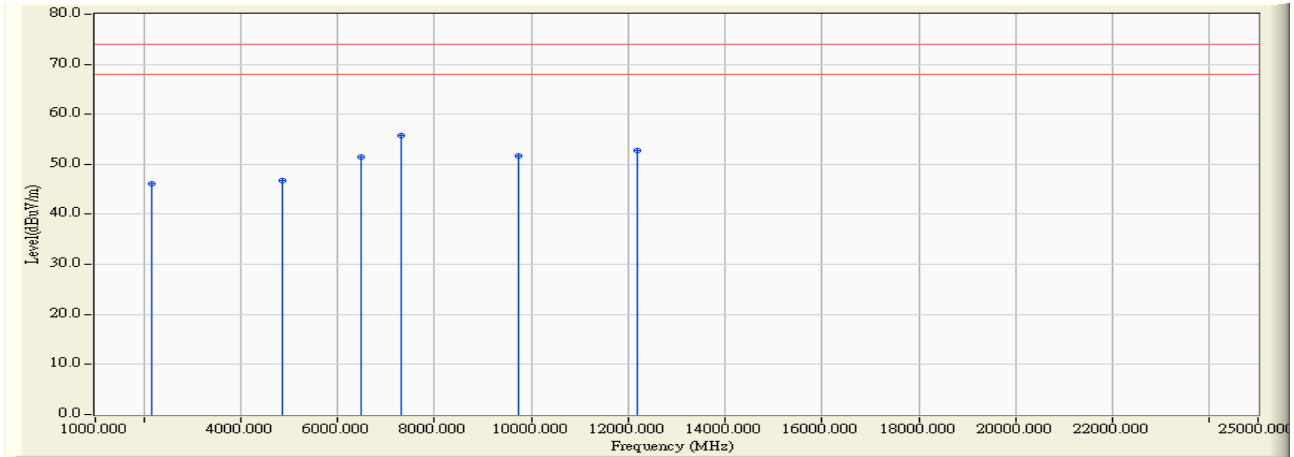

	Frequency (MHz)	Correct Factor (dB)	Reading Level (dBuV)	Measure Level (dBuV/m)	Margin (dB)	Limit (dBuV/m)	Detector Type	Ant Pos (cm)	Table Pos (deg)
1	2152.000	-4.620	50.750	46.130	-27.870	74.000	PEAK	0.000	0.000
2	4874.400	3.283	43.470	46.753	-27.247	74.000	PEAK	0.000	0.000
3	6496.000	5.066	46.440	51.506	-22.494	74.000	PEAK	0.000	0.000
4	* 7311.800	7.639	48.050	55.689	-18.311	74.000	PEAK	0.000	0.000
5	9748.000	13.951	37.800	51.751	-22.249	74.000	PEAK	0.000	0.000
6	12184.600	16.833	35.910	52.744	-21.256	74.000	PEAK	0.000	0.000

Note:

1. All readings above 1GHz are performed with peak and/or average measurements as necessary.
2. Peak measurements: RBW = 1MHz, VBW = 3 MHz, Sweep: Auto.
3. Average measurements: RBW = 1MHz, VBW = 10 Hz, Sweep: Auto.
4. " * ", means this data is the worst emission level.
5. Measurement Level = Reading Level + Correct Factor.
6. The average measurement was not performed when the peak measured data under the limit of average detection.

Site : Site 2	Time : 2008/06/18 - 16:16
Limit : FCC_SpartC_15.247_H_03M_AV	Margin : 6
Probe : CB4_FCC_1-18G(2008-05) - VERTICAL	Power : AC 120V/60Hz
EUT : WIRELESS G ADSL2+ MODEM ROUTER	Note : TX-N(20MHz)-CH6

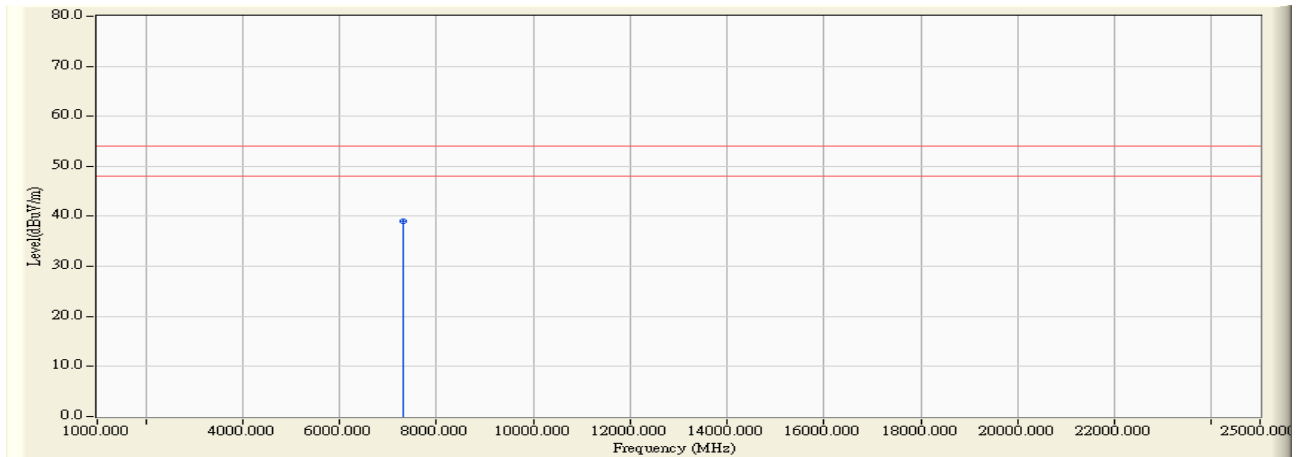

		Frequency (MHz)	Correct Factor (dB)	Reading Level (dBuV)	Measure Level (dBuV/m)	Margin (dB)	Limit (dBuV/m)	Detector Type	Ant Pos (cm)	Table Pos (deg)
1	*	7310.800	7.636	31.450	39.086	-14.914	54.000	AVERAGE	0.000	0.000

Note:

1. All readings above 1GHz are performed with peak and/or average measurements as necessary.
2. Peak measurements: RBW = 1MHz, VBW = 3 MHz, Sweep: Auto.
3. Average measurements: RBW = 1MHz, VBW = 10 Hz, Sweep: Auto.
4. “ * ”, means this data is the worst emission level.
5. Measurement Level = Reading Level + Correct Factor.
6. The average measurement was not performed when the peak measured data under the limit of average detection.

Site : Site 2	Time : 2008/06/18 - 17:29
Limit : FCC_SpartC_15.247_H_03M_PK	Margin : 6
Probe : CB4_FCC_1-18G(2008-05) - HORIZONTAL	Power : AC 120V/60Hz
EUT : WIRELESS G ADSL2+ MODEM ROUTER	Note : TX-N(40MHz)-CH3

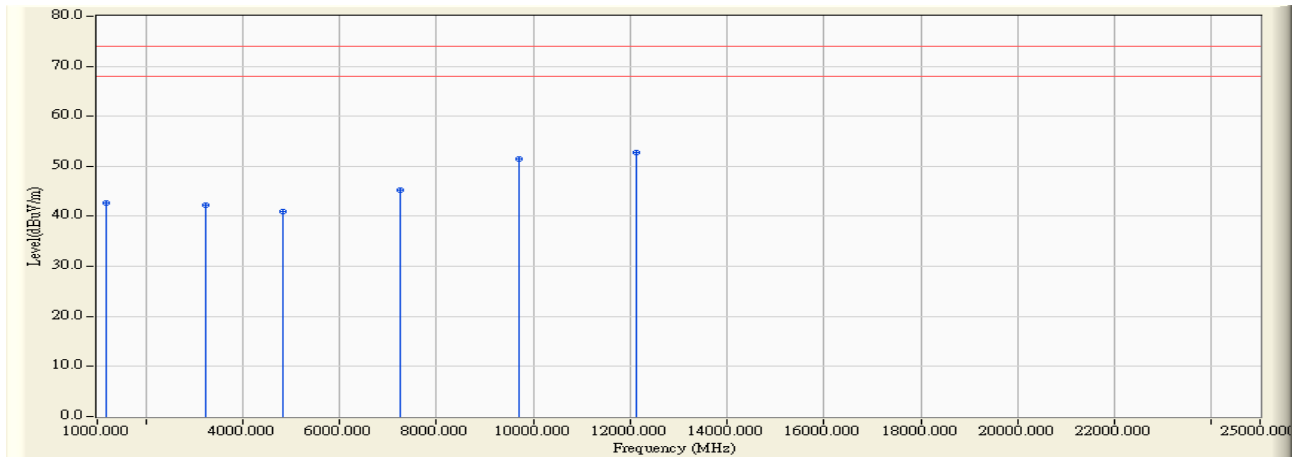

	Frequency (MHz)	Correct Factor (dB)	Reading Level (dBuV)	Measure Level (dBuV/m)	Margin (dB)	Limit (dBuV/m)	Detector Type	Ant Pos (cm)	Table Pos (deg)
1	1192.000	-8.062	50.730	42.668	-31.332	74.000	PEAK	0.000	0.000
2	3229.240	-1.931	44.090	42.159	-31.841	74.000	PEAK	0.000	0.000
3	4844.000	3.182	37.740	40.923	-33.077	74.000	PEAK	0.000	0.000
4	7266.000	7.525	37.750	45.275	-28.725	74.000	PEAK	0.000	0.000
5	9690.000	13.866	37.570	51.436	-22.564	74.000	PEAK	0.000	0.000
6	* 12114.000	16.772	35.990	52.763	-21.237	74.000	PEAK	0.000	0.000

Note:

1. All readings above 1GHz are performed with peak and/or average measurements as necessary.
2. Peak measurements: RBW = 1MHz, VBW = 3 MHz, Sweep: Auto.
3. Average measurements: RBW = 1MHz, VBW = 10 Hz, Sweep: Auto.
4. " * ", means this data is the worst emission level.
5. Measurement Level = Reading Level + Correct Factor.
6. The average measurement was not performed when the peak measured data under the limit of average detection.

Site : Site 2	Time : 2008/06/18 - 16:45
Limit : FCC_SpartC_15.247_H_03M_PK	Margin : 6
Probe : CB4_FCC_1-18G(2008-05) - VERTICAL	Power : AC 120V/60Hz
EUT : WIRELESS G ADSL2+ MODEM ROUTER	Note : TX-N(20MHz)-CH11

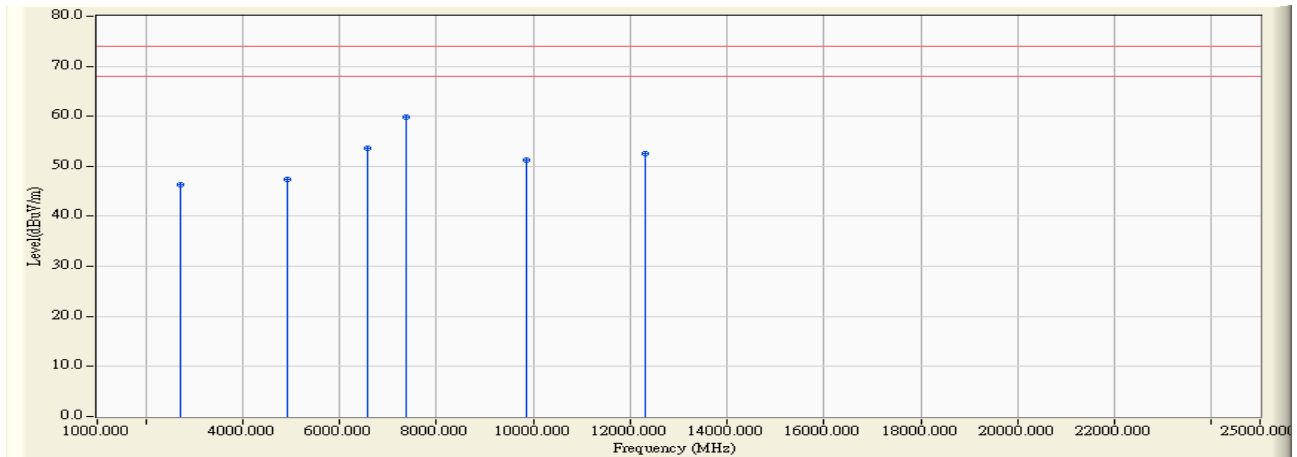

	Frequency (MHz)	Correct Factor (dB)	Reading Level (dBuV)	Measure Level (dBuV/m)	Margin (dB)	Limit (dBuV/m)	Detector Type	Ant Pos (cm)	Table Pos (deg)
1	2728.000	-2.955	49.260	46.305	-27.695	74.000	PEAK	0.000	0.000
2	4924.000	3.437	44.050	47.487	-26.513	74.000	PEAK	0.000	0.000
3	6565.380	5.161	48.560	53.722	-20.278	74.000	PEAK	0.000	0.000
4	* 7384.000	7.849	52.000	59.849	-14.151	74.000	PEAK	0.000	0.000
5	9848.000	14.075	37.150	51.225	-22.775	74.000	PEAK	0.000	0.000
6	12310.000	16.967	35.570	52.536	-21.464	74.000	PEAK	0.000	0.000

Note:

1. All readings above 1GHz are performed with peak and/or average measurements as necessary.
2. Peak measurements: RBW = 1MHz, VBW = 3 MHz, Sweep: Auto.
3. Average measurements: RBW = 1MHz, VBW = 10 Hz, Sweep: Auto.
4. " * ", means this data is the worst emission level.
5. Measurement Level = Reading Level + Correct Factor.
6. The average measurement was not performed when the peak measured data under the limit of average detection.

Site : Site 2	Time : 2008/06/18 - 16:46
Limit : FCC_SpartC_15.247_H_03M_AV	Margin : 6
Probe : CB4_FCC_1-18G(2008-05) - VERTICAL	Power : AC 120V/60Hz
EUT : WIRELESS G ADSL2+ MODEM ROUTER	Note : TX-N(20MHz)-CH11

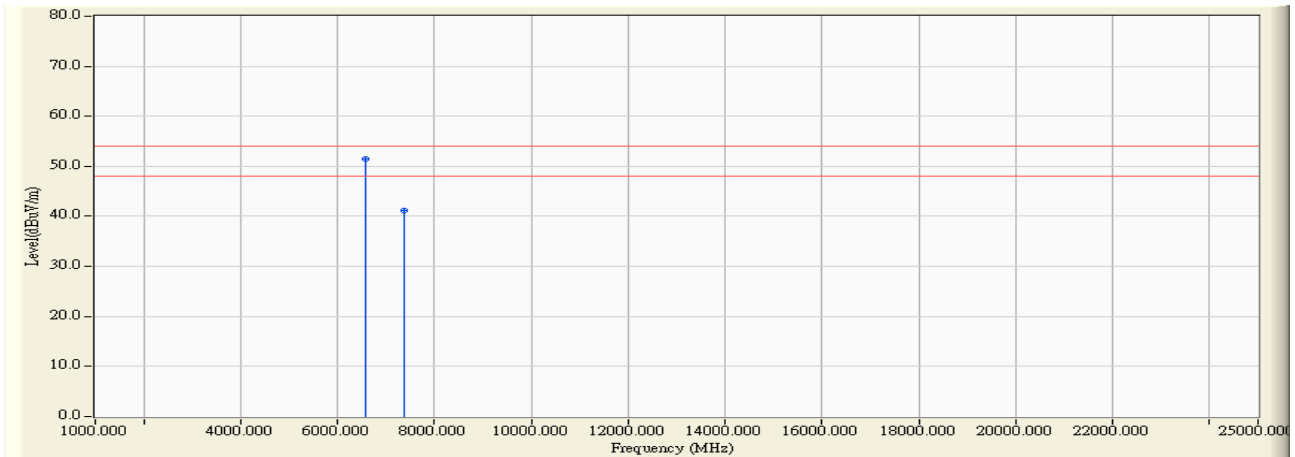

		Frequency (MHz)	Correct Factor (dB)	Reading Level (dBuV)	Measure Level (dBuV/m)	Margin (dB)	Limit (dBuV/m)	Detector Type	Ant Pos (cm)	Table Pos (deg)
1	*	6565.380	5.161	46.340	51.502	-2.498	54.000	AVERAGE	0.000	0.000
2		7386.000	7.853	33.420	41.273	-12.727	54.000	AVERAGE	0.000	0.000

Note:

1. All readings above 1GHz are performed with peak and/or average measurements as necessary.
2. Peak measurements: RBW = 1MHz, VBW = 3 MHz, Sweep: Auto.
3. Average measurements: RBW = 1MHz, VBW = 10 Hz, Sweep: Auto.
4. “ * ”, means this data is the worst emission level.
5. Measurement Level = Reading Level + Correct Factor.
6. The average measurement was not performed when the peak measured data under the limit of average detection.

Site : Site 2	Time : 2008/06/18 - 17:29
Limit : FCC_SpartC_15.247_H_03M_PK	Margin : 6
Probe : CB4_FCC_1-18G(2008-05) - HORIZONTAL	Power : AC 120V/60Hz
EUT : WIRELESS G ADSL2+ MODEM ROUTER	Note : TX-N(40MHz)-CH3

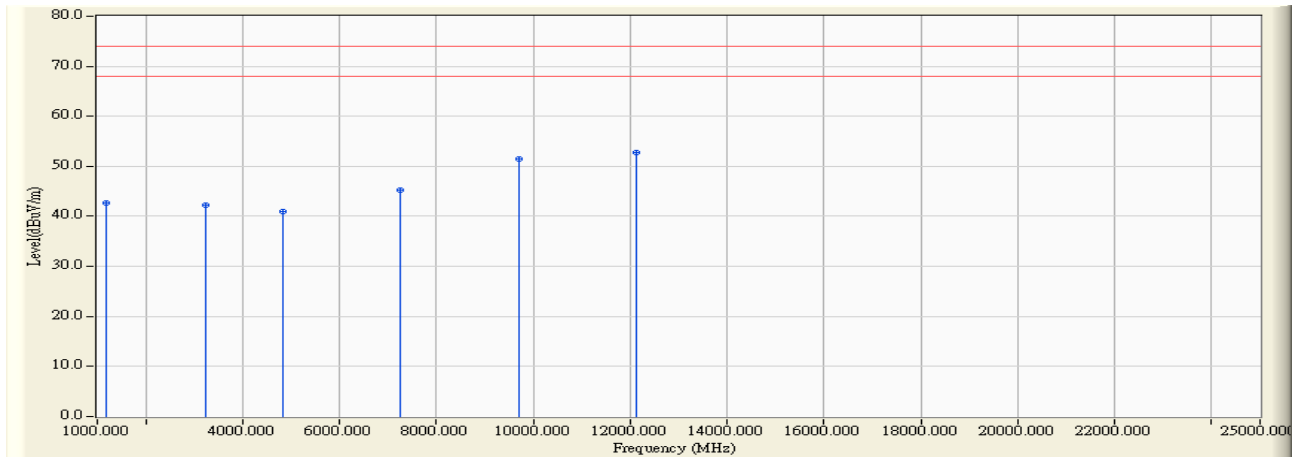

	Frequency (MHz)	Correct Factor (dB)	Reading Level (dBuV)	Measure Level (dBuV/m)	Margin (dB)	Limit (dBuV/m)	Detector Type	Ant Pos (cm)	Table Pos (deg)
1	1192.000	-8.062	50.730	42.668	-31.332	74.000	PEAK	0.000	0.000
2	3229.240	-1.931	44.090	42.159	-31.841	74.000	PEAK	0.000	0.000
3	4844.000	3.182	37.740	40.923	-13.077	54.000	PEAK	0.000	0.000
4	7266.000	7.525	37.750	45.275	-8.725	54.000	PEAK	0.000	0.000
5	9690.000	13.866	37.570	51.436	-2.564	54.000	PEAK	0.000	0.000
6	* 12114.000	16.772	35.990	52.763	-1.237	54.000	PEAK	0.000	0.000

Note:

1. All readings above 1GHz are performed with peak and/or average measurements as necessary.
2. Peak measurements: RBW = 1MHz, VBW = 3 MHz, Sweep: Auto.
3. Average measurements: RBW = 1MHz, VBW = 10 Hz, Sweep: Auto.
4. " * ", means this data is the worst emission level.
5. Measurement Level = Reading Level + Correct Factor.
6. The average measurement was not performed when the peak measured data under the limit of average detection.

Site : Site 2	Time : 2008/06/18 - 17:36
Limit : FCC_SpartC_15.247_H_03M_PK	Margin : 6
Probe : CB4_FCC_1-18G(2008-05) - VERTICAL	Power : AC 120V/60Hz
EUT : WIRELESS G ADSL2+ MODEM ROUTER	Note : TX-N(40MHz)-CH3

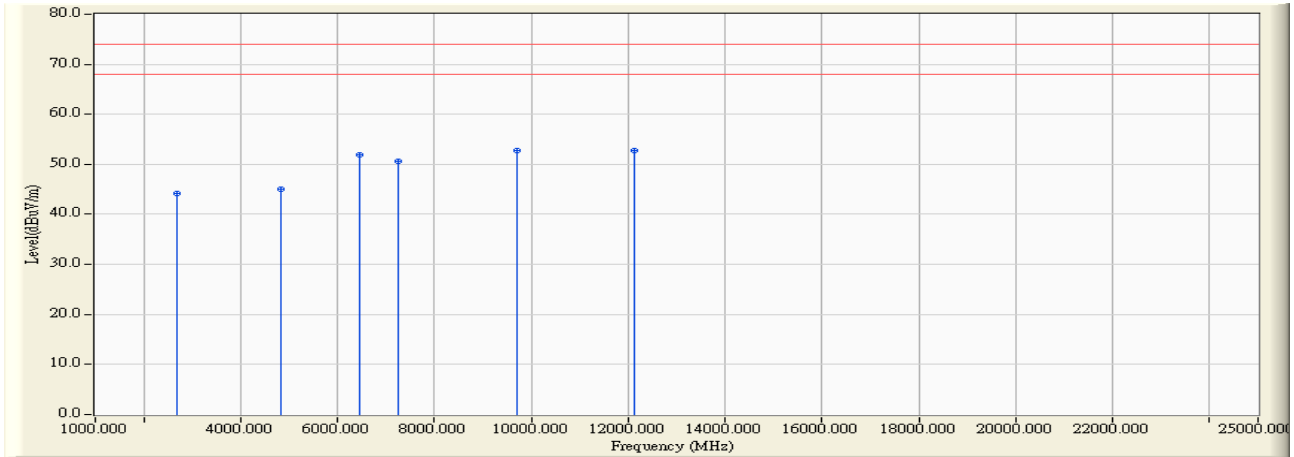

	Frequency (MHz)	Correct Factor (dB)	Reading Level (dBuV)	Measure Level (dBuV/m)	Margin (dB)	Limit (dBuV/m)	Detector Type	Ant Pos (cm)	Table Pos (deg)
1	2680.000	-3.051	47.230	44.180	-29.820	74.000	PEAK	0.000	0.000
2	4844.000	3.182	41.790	44.973	-29.027	74.000	PEAK	0.000	0.000
3	6458.560	5.028	46.830	51.858	-22.142	74.000	PEAK	0.000	0.000
4	7266.000	6.992	43.620	50.612	-23.388	74.000	PEAK	0.000	0.000
5	9690.000	15.243	37.460	52.703	-21.297	74.000	PEAK	0.000	0.000
6	* 12114.000	17.003	35.860	52.863	-21.137	74.000	PEAK	0.000	0.000

Note:

1. All readings above 1GHz are performed with peak and/or average measurements as necessary.
2. Peak measurements: RBW = 1MHz, VBW = 3 MHz, Sweep: Auto.
3. Average measurements: RBW = 1MHz, VBW = 10 Hz, Sweep: Auto.
4. " * ", means this data is the worst emission level.
5. Measurement Level = Reading Level + Correct Factor.
6. The average measurement was not performed when the peak measured data under the limit of average detection.

Site : Site 2	Time : 2008/06/18 - 17:56
Limit : FCC_SpartC_15.247_H_03M_PK	Margin : 6
Probe : CB4_FCC_1-18G(2008-05) - HORIZONTAL	Power : AC 120V/60Hz
EUT : WIRELESS G ADSL2+ MODEM ROUTER	Note : TX-N(40MHz)-CH6

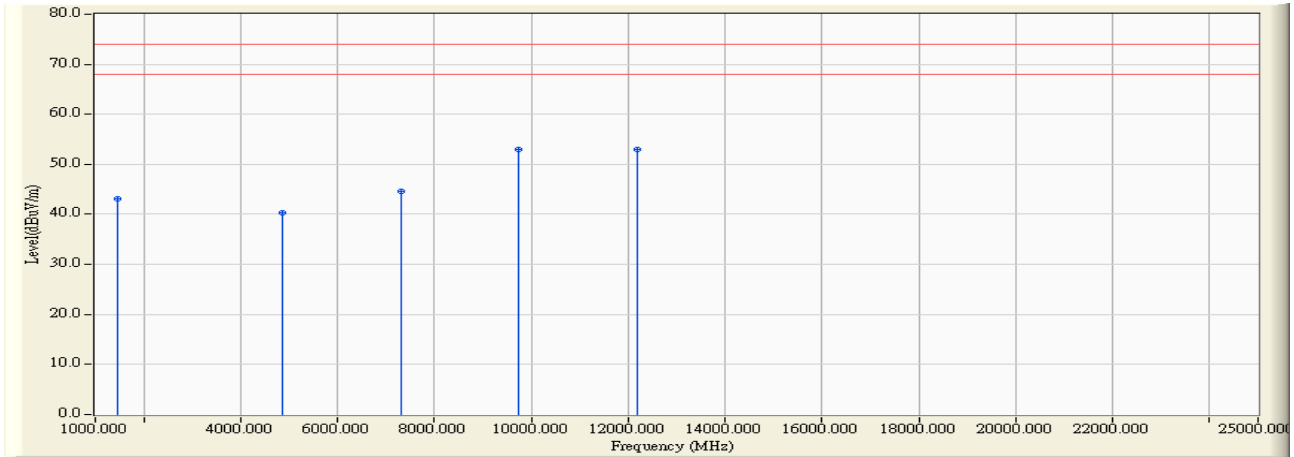

	Frequency (MHz)	Correct Factor (dB)	Reading Level (dBuV)	Measure Level (dBuV/m)	Margin (dB)	Limit (dBuV/m)	Detector Type	Ant Pos (cm)	Table Pos (deg)
1	1466.030	-7.031	50.200	43.170	-30.830	74.000	PEAK	0.000	0.000
2	4876.000	3.289	37.090	40.379	-33.621	74.000	PEAK	0.000	0.000
3	7321.000	7.021	37.660	44.681	-29.319	74.000	PEAK	0.000	0.000
4	* 9750.000	15.455	37.480	52.935	-21.065	74.000	PEAK	0.000	0.000
5	12187.000	17.209	35.660	52.869	-21.131	74.000	PEAK	0.000	0.000

Note:

1. All readings above 1GHz are performed with peak and/or average measurements as necessary.
2. Peak measurements: RBW = 1MHz, VBW = 3 MHz, Sweep: Auto.
3. Average measurements: RBW = 1MHz, VBW = 10 Hz, Sweep: Auto.
4. " * ", means this data is the worst emission level.
5. Measurement Level = Reading Level + Correct Factor.
6. The average measurement was not performed when the peak measured data under the limit of average detection.

Site : Site 2	Time : 2008/06/18 - 18:03
Limit : FCC_SpartC_15.247_H_03M_PK	Margin : 6
Probe : CB4_FCC_1-18G(2008-05) - VERTICAL	Power : AC 120V/60Hz
EUT : WIRELESS G ADSL2+ MODEM ROUTER	Note : TX-N(40MHz)-CH6

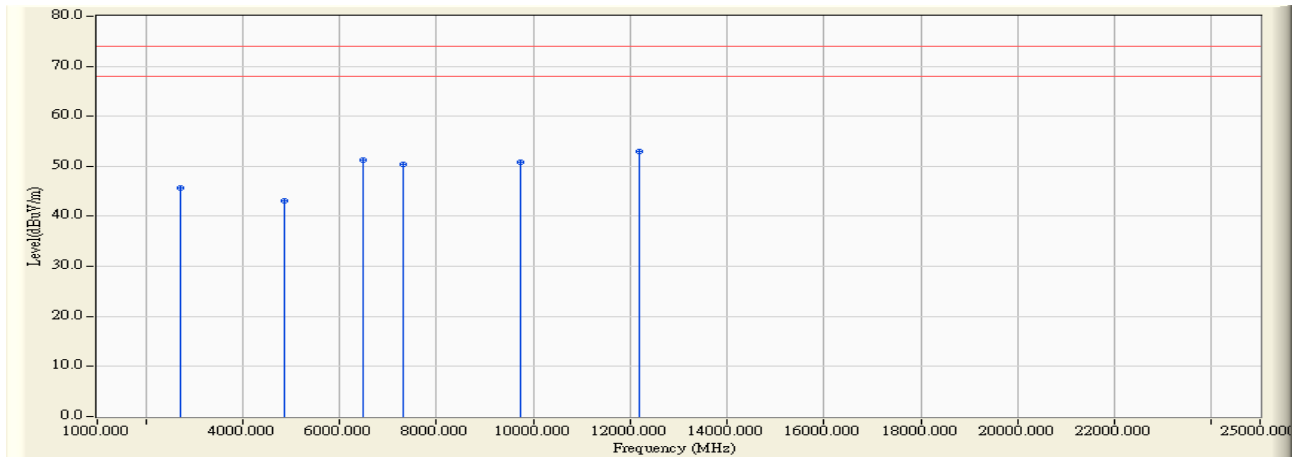

	Frequency (MHz)	Correct Factor (dB)	Reading Level (dBuV)	Measure Level (dBuV/m)	Margin (dB)	Limit (dBuV/m)	Detector Type	Ant Pos (cm)	Table Pos (deg)
1	2704.000	-3.000	48.580	45.581	-28.419	74.000	PEAK	0.000	0.000
2	4876.000	3.289	39.820	43.109	-30.891	74.000	PEAK	0.000	0.000
3	6499.000	5.071	46.220	51.290	-22.710	74.000	PEAK	0.000	0.000
4	7321.000	7.664	42.750	50.414	-23.586	74.000	PEAK	0.000	0.000
5	9750.000	13.954	36.980	50.934	-23.066	74.000	PEAK	0.000	0.000
6	* 12187.000	16.837	36.080	52.917	-21.083	74.000	PEAK	0.000	0.000

Note:

1. All readings above 1GHz are performed with peak and/or average measurements as necessary.
2. Peak measurements: RBW = 1MHz, VBW = 3 MHz, Sweep: Auto.
3. Average measurements: RBW = 1MHz, VBW = 10 Hz, Sweep: Auto.
4. " * ", means this data is the worst emission level.
5. Measurement Level = Reading Level + Correct Factor.
6. The average measurement was not performed when the peak measured data under the limit of average detection.

Site : Site 2	Time : 2008/06/18 - 19:02
Limit : FCC_SpartC_15.247_H_03M_PK	Margin : 6
Probe : CB4_FCC_1-18G(2008-05) - HORIZONTAL	Power : AC 120V/60Hz
EUT : WIRELESS G ADSL2+ MODEM ROUTER	Note : TX-N(40MHz)-CH9

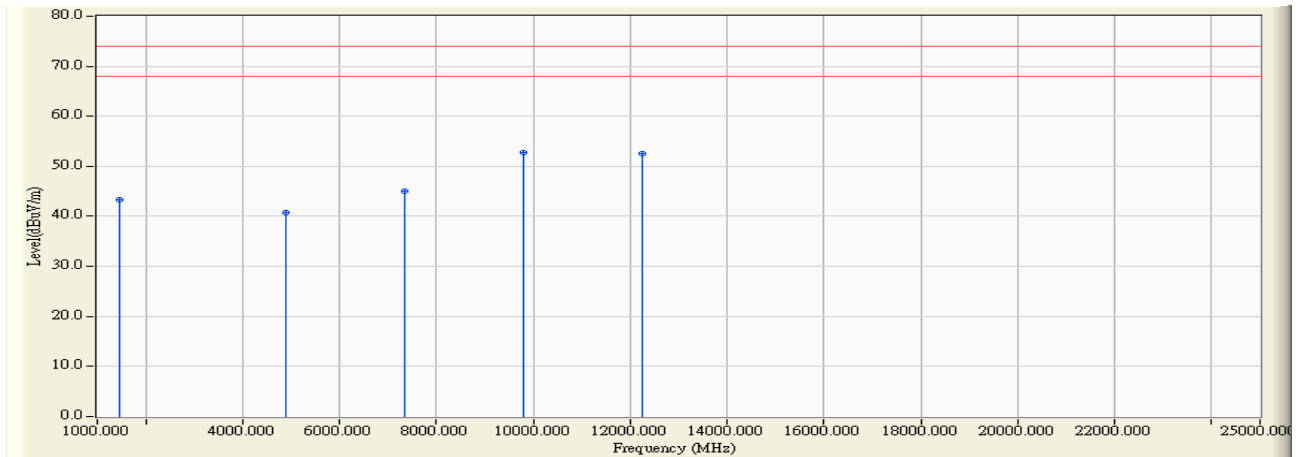

	Frequency (MHz)	Correct Factor (dB)	Reading Level (dBuV)	Measure Level (dBuV/m)	Margin (dB)	Limit (dBuV/m)	Detector Type	Ant Pos (cm)	Table Pos (deg)
1	1466.030	-7.031	50.330	43.300	-30.700	74.000	PEAK	0.000	0.000
2	4904.020	3.371	37.440	40.811	-33.189	74.000	PEAK	0.000	0.000
3	7356.000	7.062	38.020	45.082	-28.918	74.000	PEAK	0.000	0.000
4	* 9808.000	15.643	37.210	52.853	-21.147	74.000	PEAK	0.000	0.000
5	12260.000	17.432	35.210	52.642	-21.358	74.000	PEAK	0.000	0.000

Note:

1. All readings above 1GHz are performed with peak and/or average measurements as necessary.
2. Peak measurements: RBW = 1MHz, VBW = 3 MHz, Sweep: Auto.
3. Average measurements: RBW = 1MHz, VBW = 10 Hz, Sweep: Auto.
4. " * ", means this data is the worst emission level.
5. Measurement Level = Reading Level + Correct Factor.
6. The average measurement was not performed when the peak measured data under the limit of average detection.

Site : Site 2	Time : 2008/06/18 - 19:18
Limit : FCC_SpartC_15.247_H_03M_PK	Margin : 6
Probe : CB4_FCC_1-18G(2008-05) - VERTICAL	Power : AC 120V/60Hz
EUT : WIRELESS G ADSL2+ MODEM ROUTER	Note : TX-N(40MHz)-CH9

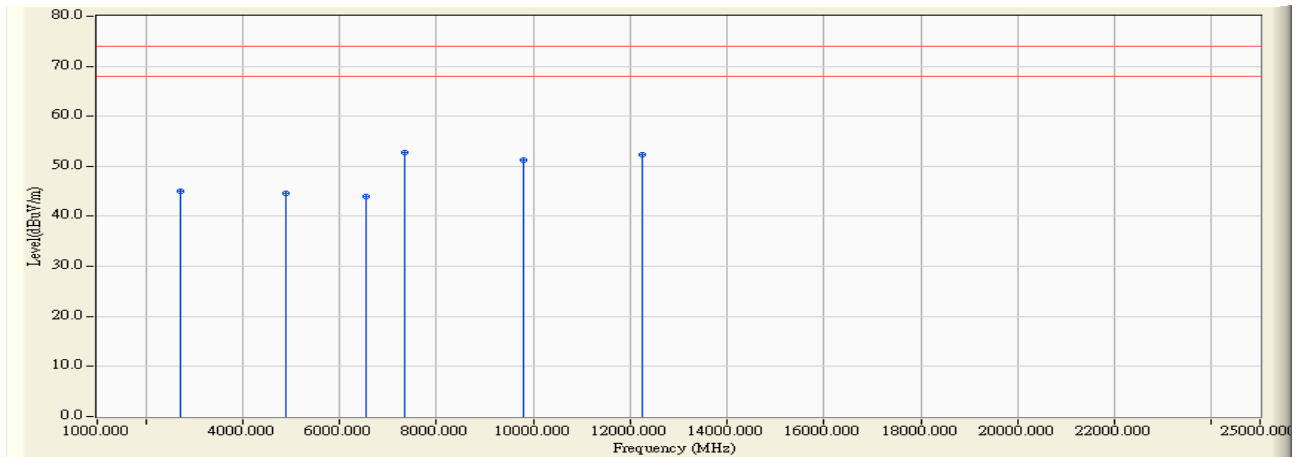

	Frequency (MHz)	Correct Factor (dB)	Reading Level (dBuV)	Measure Level (dBuV/m)	Margin (dB)	Limit (dBuV/m)	Detector Type	Ant Pos (cm)	Table Pos (deg)
1	2728.000	-2.955	48.040	45.085	-28.915	74.000	PEAK	0.000	0.000
2	4904.000	3.371	41.270	44.641	-29.359	74.000	PEAK	0.000	0.000
3	6538.700	5.121	38.780	43.901	-30.099	74.000	PEAK	0.000	0.000
4	* 7356.000	7.778	45.020	52.797	-21.203	74.000	PEAK	0.000	0.000
5	9808.000	14.029	37.330	51.359	-22.641	74.000	PEAK	0.000	0.000
6	12260.000	16.912	35.340	52.252	-21.748	74.000	PEAK	0.000	0.000

Note:

1. All readings above 1GHz are performed with peak and/or average measurements as necessary.
2. Peak measurements: RBW = 1MHz, VBW = 3 MHz, Sweep: Auto.
3. Average measurements: RBW = 1MHz, VBW = 10 Hz, Sweep: Auto.
4. " * ", means this data is the worst emission level.
5. Measurement Level = Reading Level + Correct Factor.
6. The average measurement was not performed when the peak measured data under the limit of average detection.

5. RF Antenna Conducted Test

5.1. Test Equipment

RF Conducted Measurement:				
Item	Equipment	Manufacturer	Model No. / Serial No.	Last Cal.
1	Spectrum Analyzer	R & S	FSP / 100561	Jan., 2008
2	No.1 OATS			Sep., 2007

Note: 1. All equipments are calibrated every one year.
 2. The test instruments Marked "X" are used to measure the final test results.

5.2. Test Setup

RF Antenna Conducted Measurement:

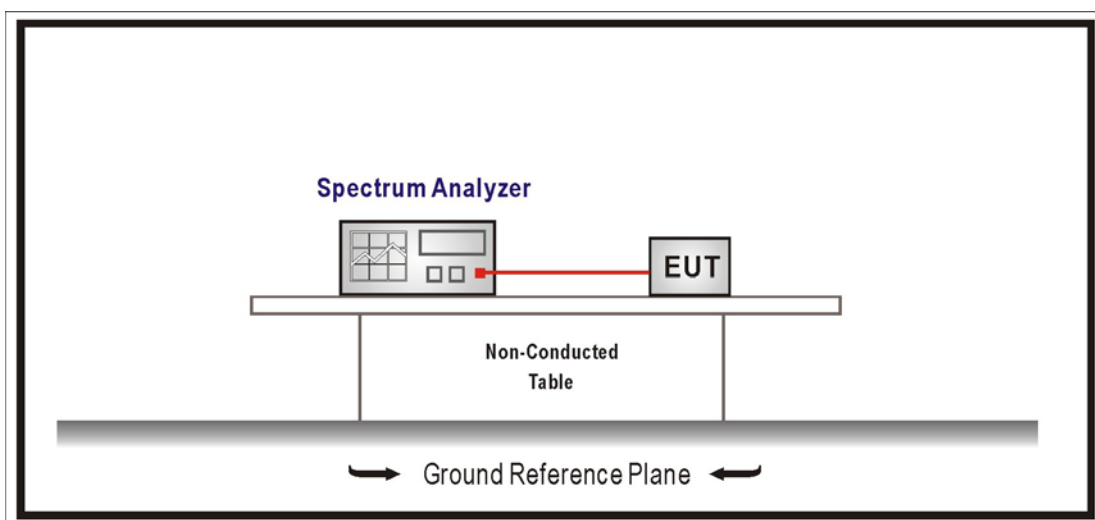

5.3. Limits

According to RSS-210 Issue 7, Annex 8.5 (June. 2007). In any 100 kHz bandwidth outside the frequency band in which the spread spectrum or digitally modulated device is operating, the radio frequency power that is produced shall be at least 20 dB below that in the 100 kHz bandwidth within the band that contains the highest level of the desired power, based on either an RF conducted measurement, provided the transmitter demonstrates compliance with the peak conducted power limits.

5.4. Test Procedure

The EUT was setup to ANSI C63.4, 2003; According to RSS-210 Issue 7, Annex 8,5 (June. 2007)

5.5. Uncertainty

± 150Hz

5.6. Test Result

Product	WIRELESS G ADSL2+ MODEM ROUTER		
Test Item	RF antenna conducted test		
Test Mode	Transmit		
Date of Test	2008/06/30	Test Site	No.1 OATS

IEEE 802.11b, Antenna Gain: 1.8dBi, Duty Cycle: 1				
Channel No.	Frequency (MHz)	Measure Level (dBc)	Limit (dBc)	Result
1	2412	41.37	> 30	Pass
11	2462	46.97	> 30	Pass

Channel 01 (2412MHz)

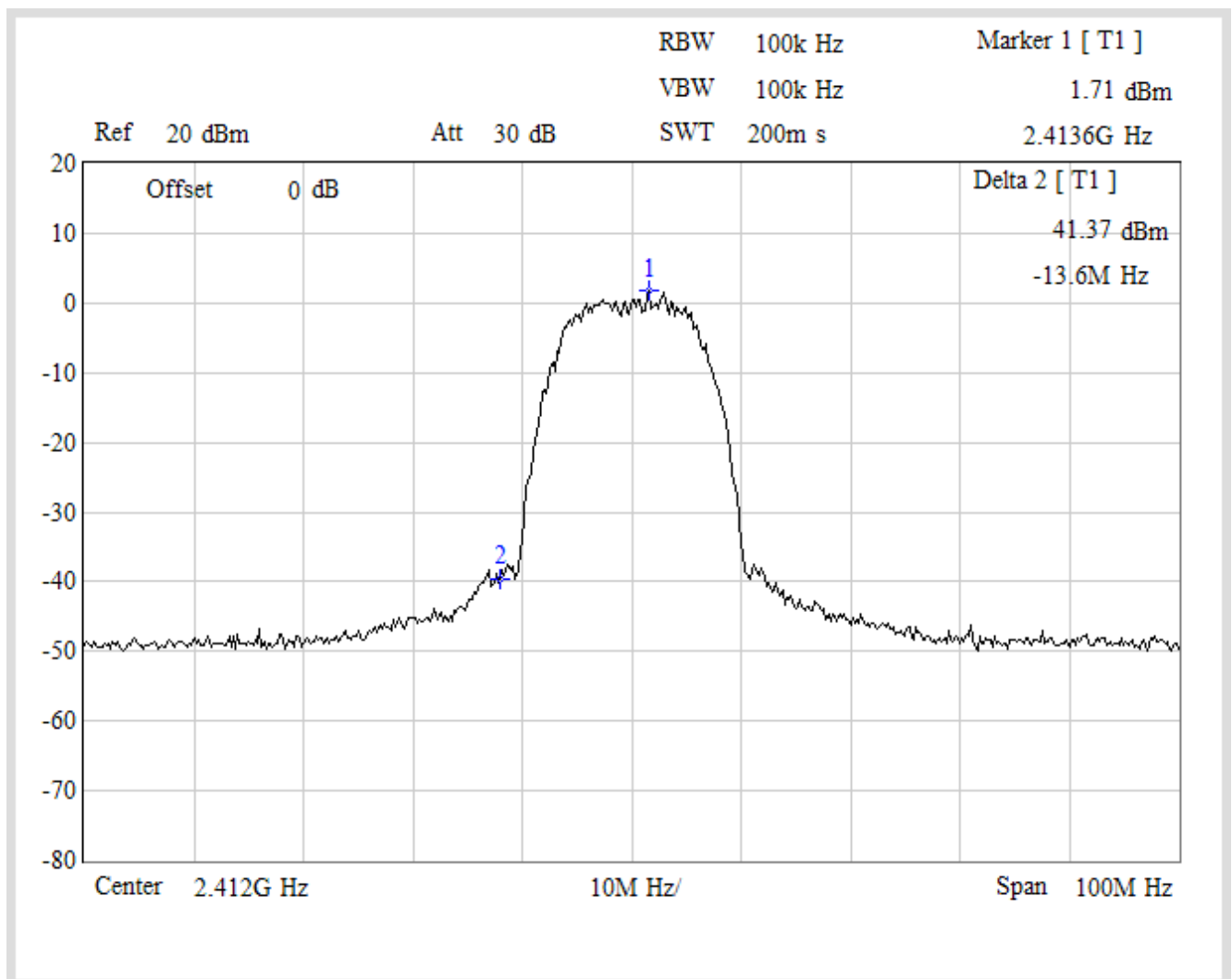

Channel 11 (2462MHz)

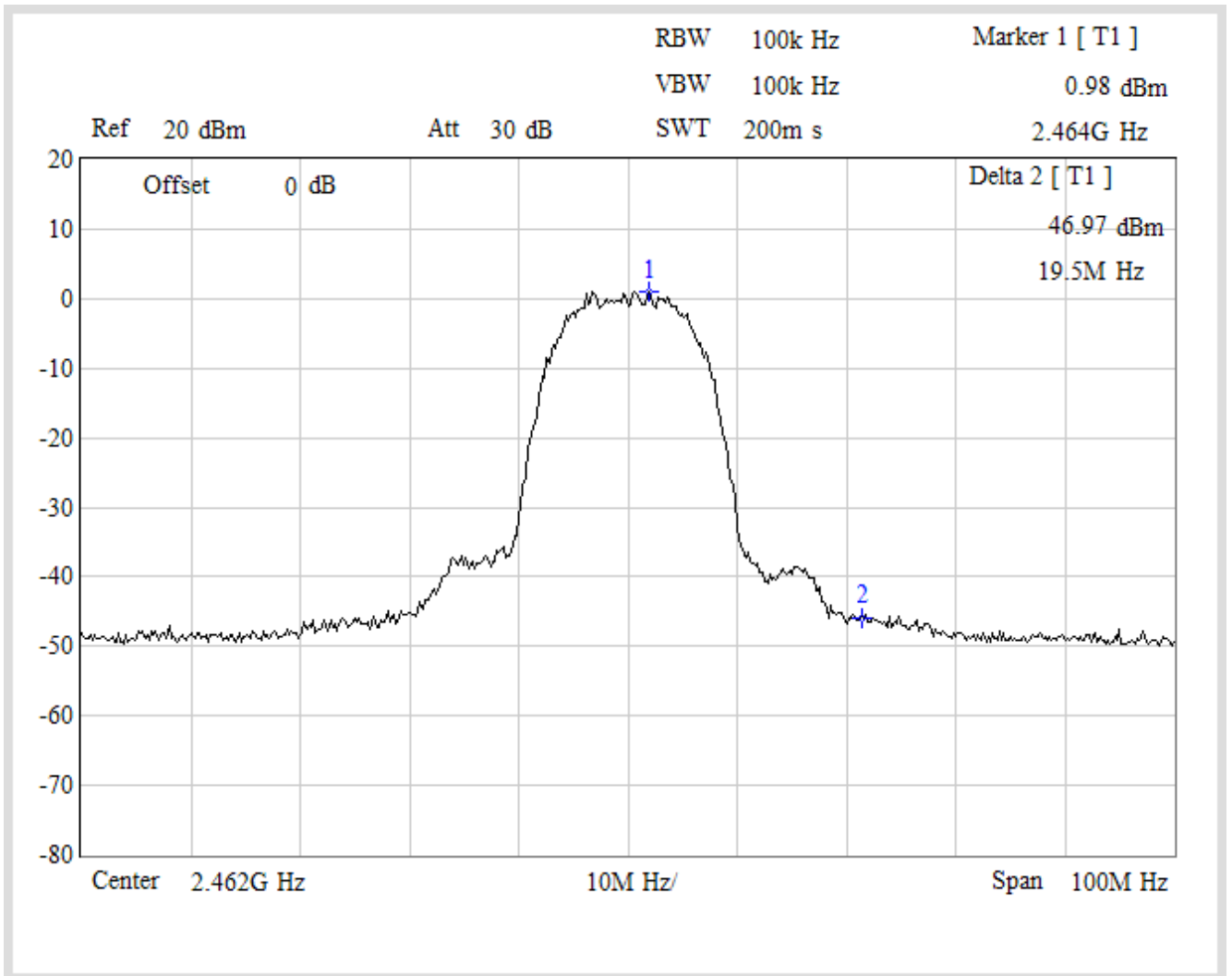

Product	WIRELESS G ADSL2+ MODEM ROUTER		
Test Item	RF antenna conducted test		
Test Mode	Transmit		
Date of Test	2008/06/30	Test Site	No.1 OATS

IEEE 802.11g, Antenna Gain: 1.8dBi, Duty Cycle: 1				
Channel No.	Frequency (MHz)	Measure Level (dBc)	Limit (dBc)	Result
1	2412	32.18	> 30	Pass
11	2462	45.39	> 30	Pass

Channel 01 (2412MHz)

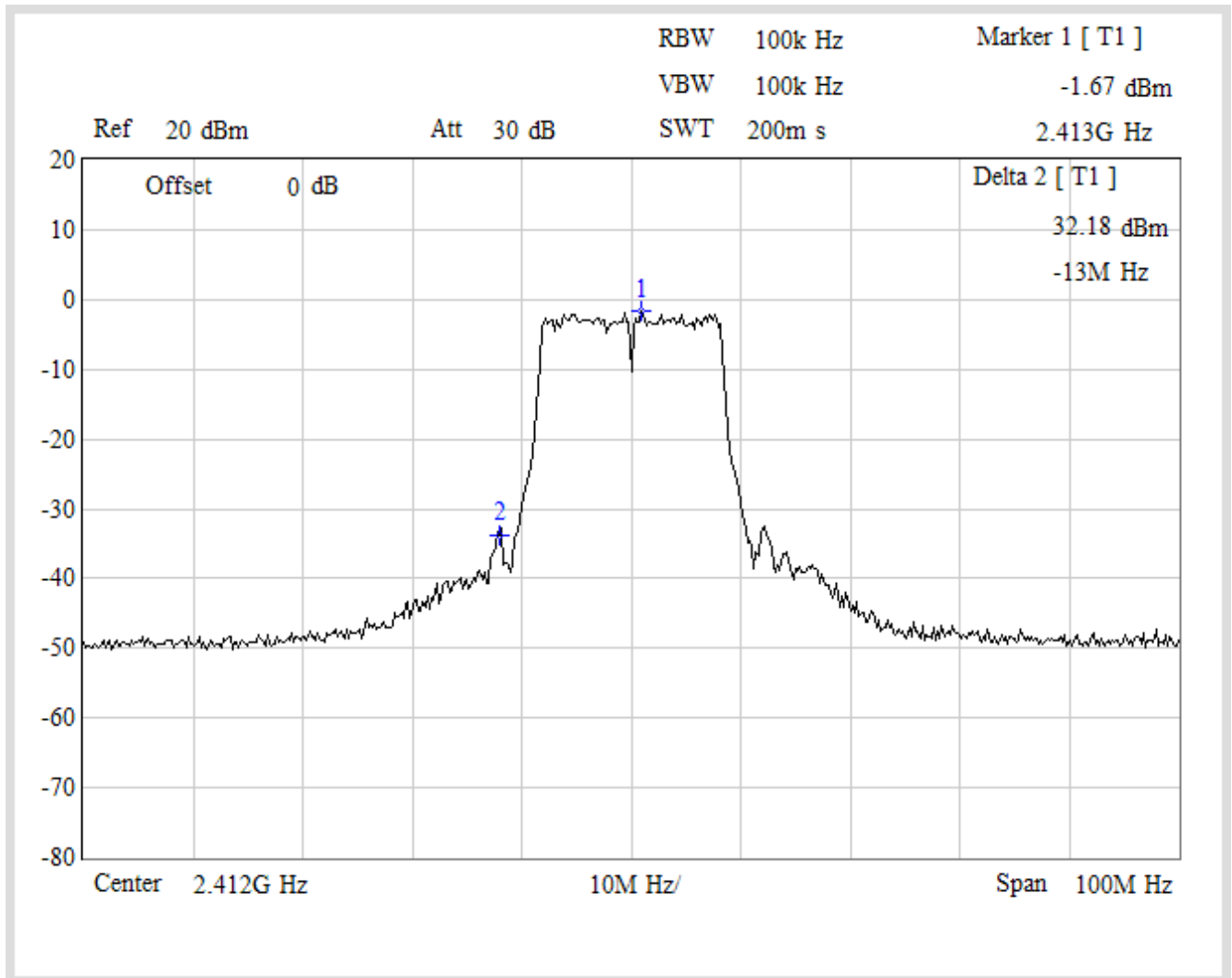

Channel 11 (2462MHz)

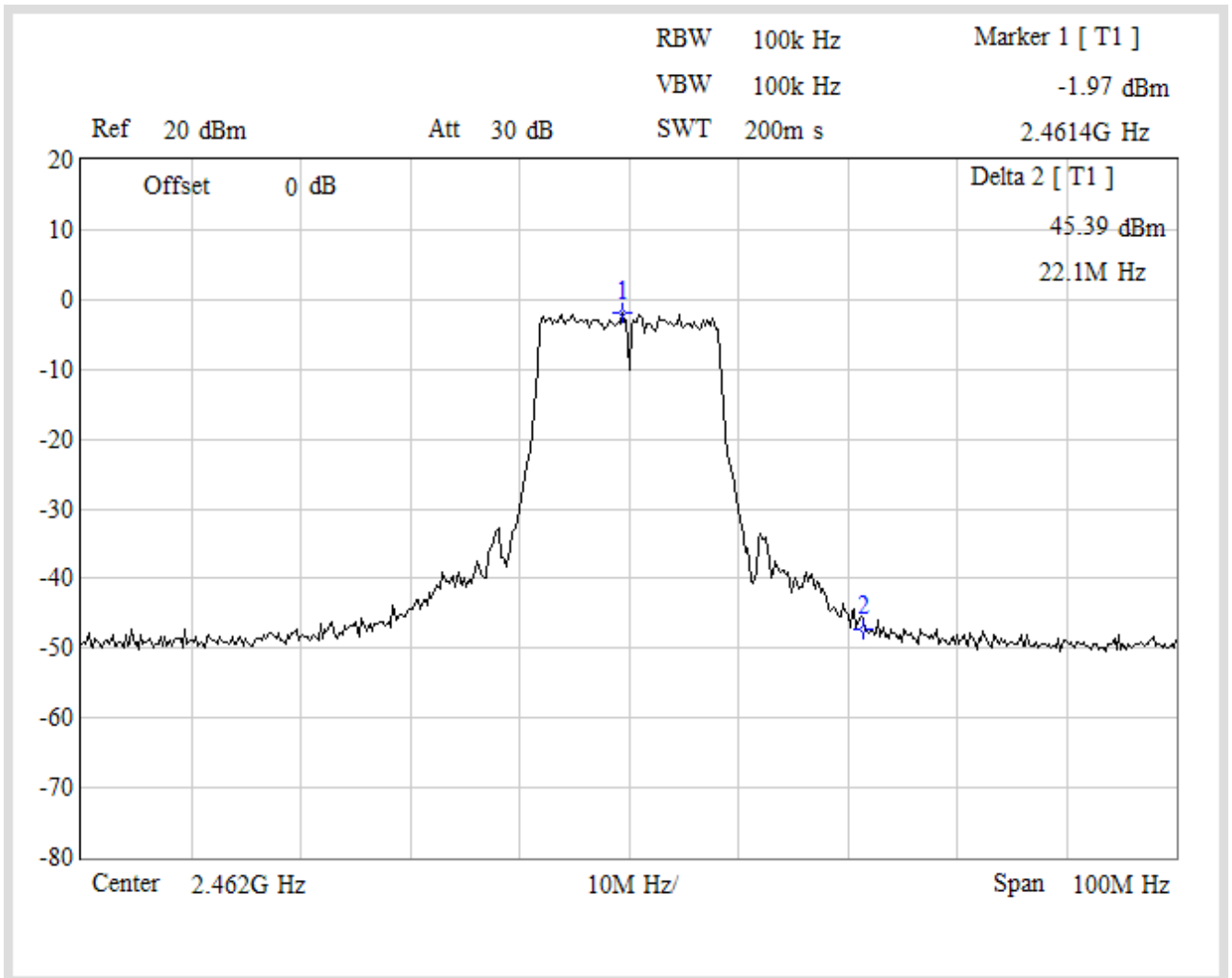

Channel 11 (2462MHz)

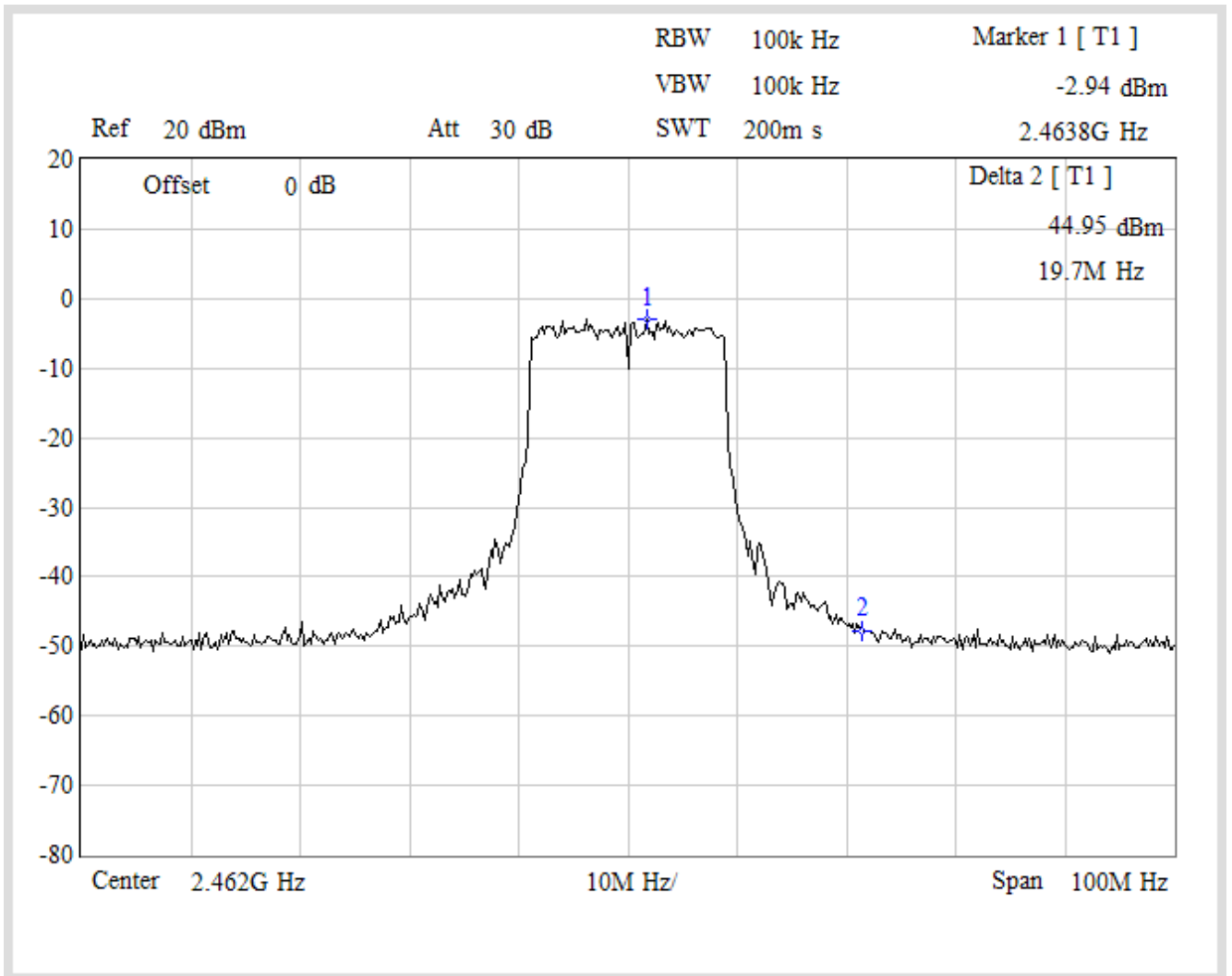

Product	WIRELESS G ADSL2+ MODEM ROUTER		
Test Item	RF antenna conducted test		
Test Mode	Transmit		
Date of Test	2008/06/30	Test Site	No.1 OATS

IEEE 802.11n (ANT A (40MHz)), Antenna Gain: 1.8dBi, Duty Cycle: 1				
Channel No.	Frequency (MHz)	Measure Level (dBm)	Limit (dBm)	Result
3	2422	30.64	> 30	Pass
9	2452	42.00	> 30	Pass

Channel 3 (2422MHz)

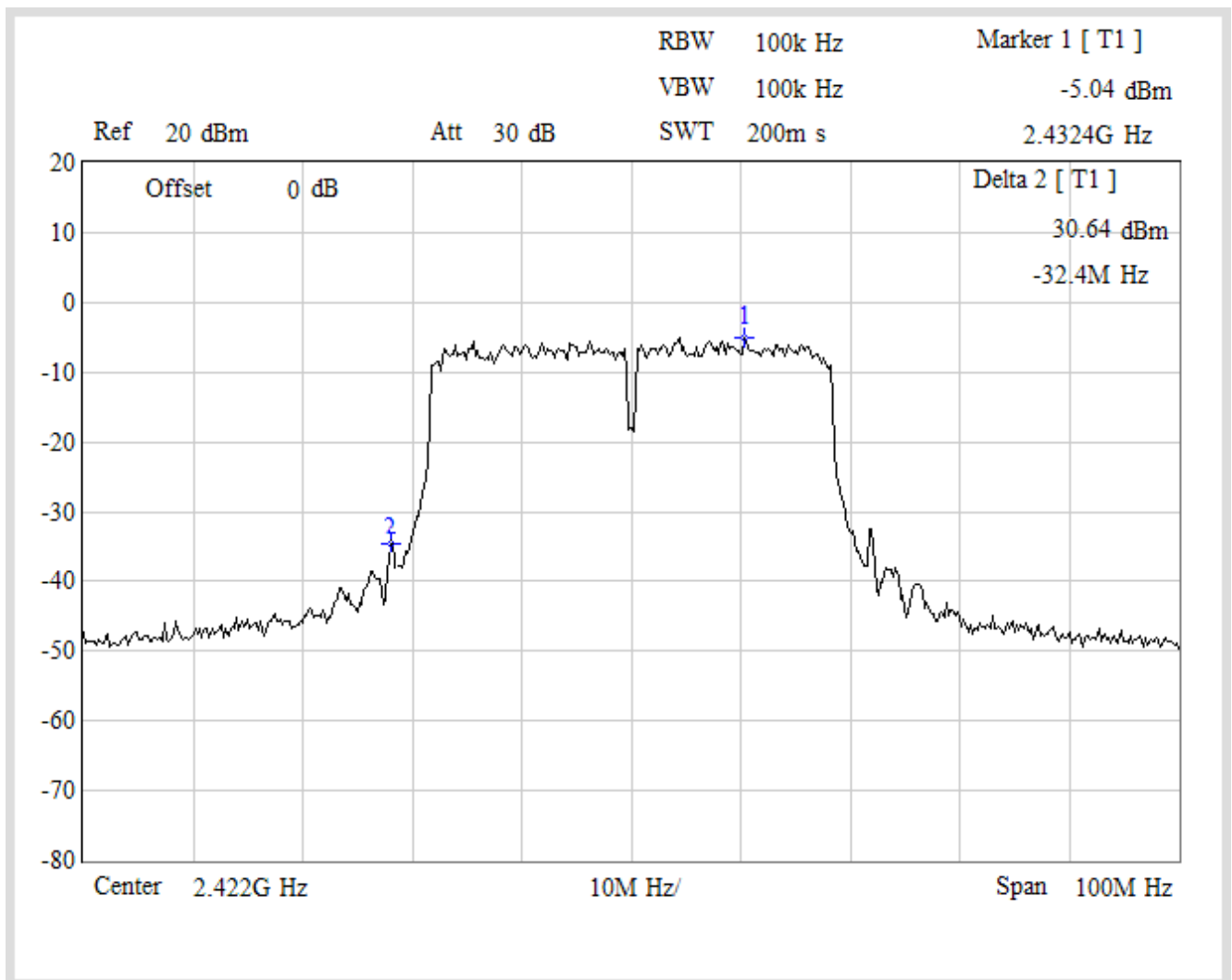

Channel 9 (2452MHz)

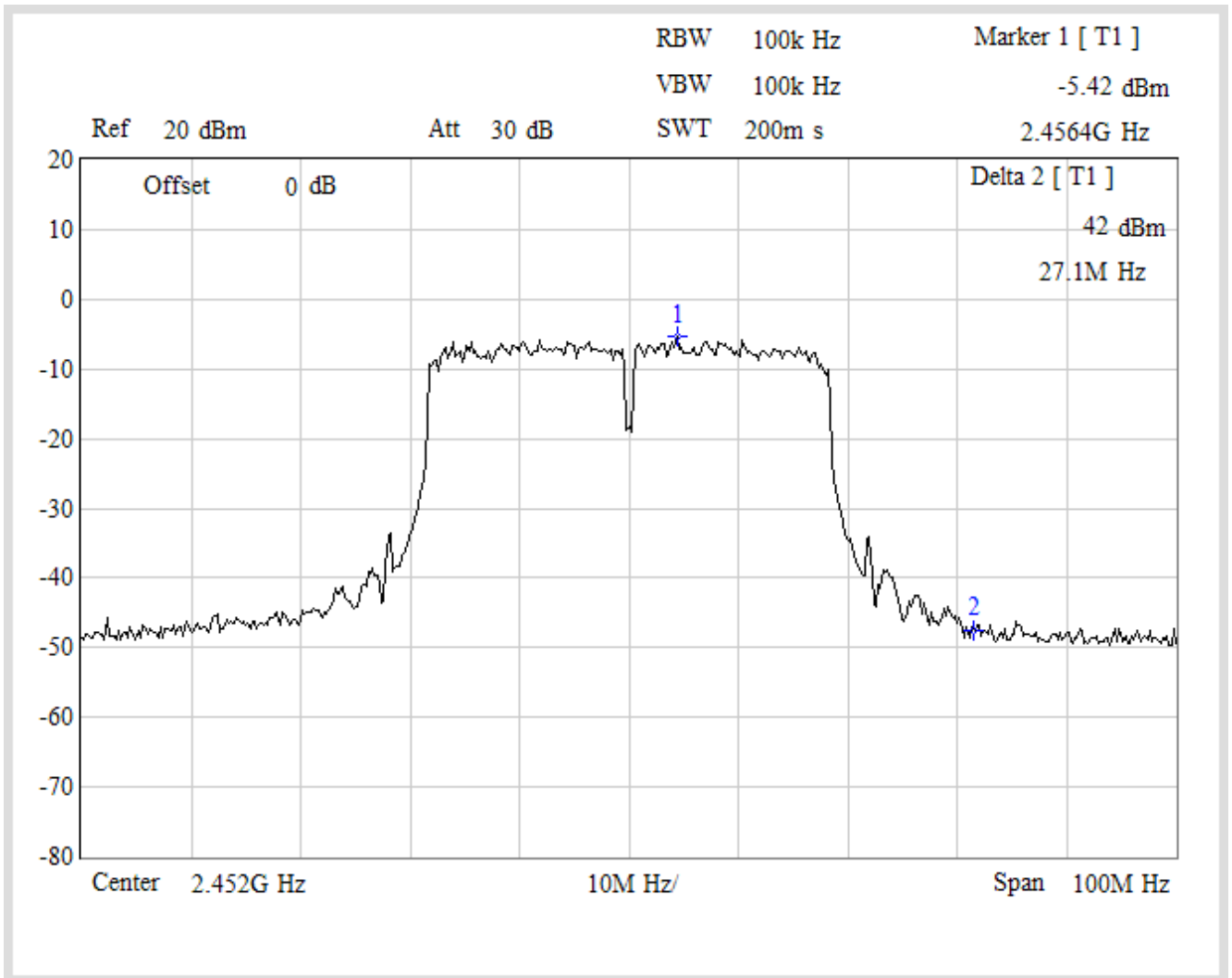

Product	WIRELESS G ADSL2+ MODEM ROUTER		
Test Item	RF antenna conducted test		
Test Mode	Transmit		
Date of Test	2008/06/30	Test Site	No.1 OATS

IEEE 802.11n (ANT B (40MHz)), Antenna Gain: 1.8dBi, Duty Cycle: 1				
Channel No.	Frequency (MHz)	Measure Level (dBm)	Limit (dBm)	Result
3	2422	31.25	> 30	Pass
9	2452	41.52	> 30	Pass

Channel 3 (2422MHz)

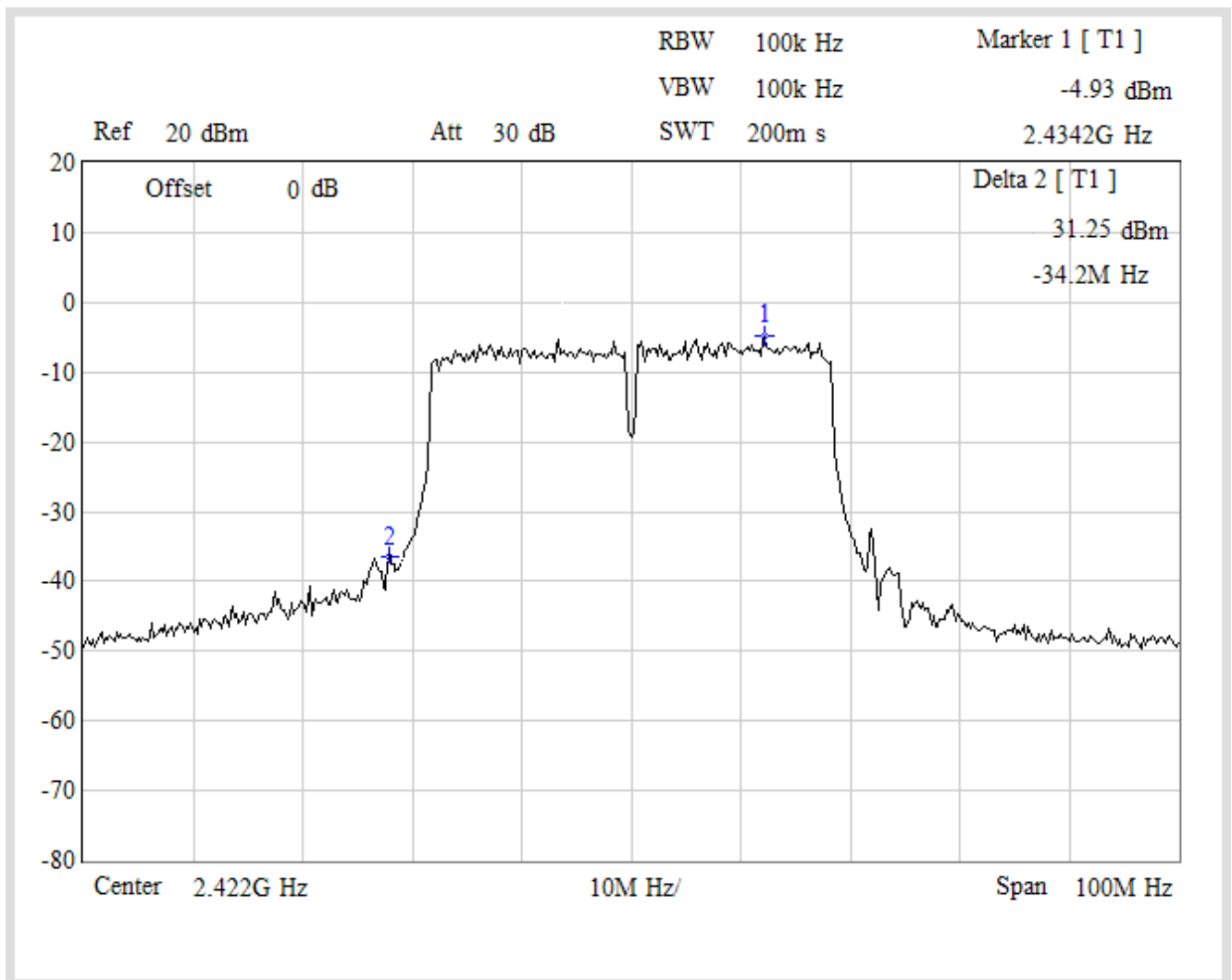

Channel 9 (2452MHz)

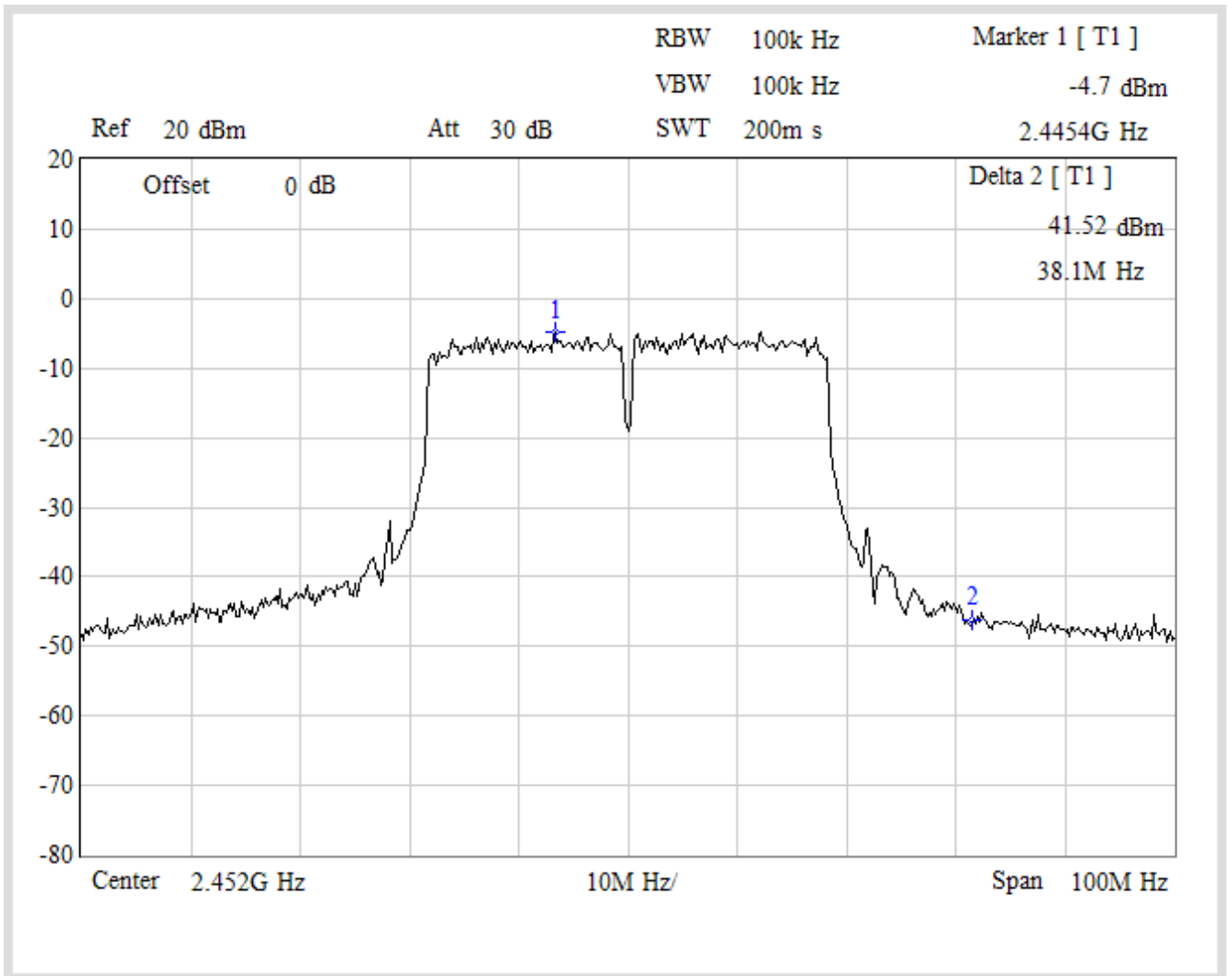

6. Band Edge

6.1. Test Equipment

The following test equipments are used during the band edge tests:

RF Radiated Measurement:					
Item		Equipment	Manufacturer	Model No. / Serial No.	Last Cal.
1	X	Spectrum Analyzer	R & S	FSP40 / 100005	Aug., 2007
2	X	Pre-Amplifier	HP	8449B / 3008A01123	Feb., 2008
3		Loop Antenna	R & S	HFH2-Z2 / 833799/004	Sep., 2007
4		BiconiLog Antenna	Schwarzbeck	VULB 9166 / 1061	Sep., 2007
5		Bilog Antenna	Chase	CBL6112B / 2455	Sep., 2007
6	X	Horn Antenna	Schwarzbeck	BBHA 9120D / BBHA9120D312	Sep., 2007
7		No.1 OATS			Sep., 2007

- Note:
1. All equipments that need to calibrate are with calibration period of 1 year.
 2. Mark "X" test instruments are used to measure the final test results.

6.2. Test Setup

RF Conducted Measurement:

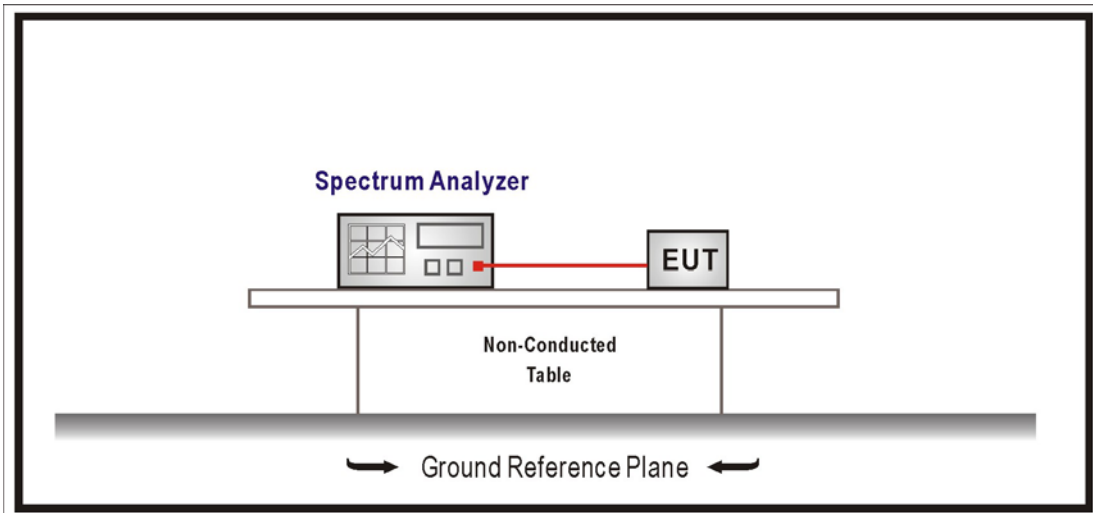

RF Radiated Measurement:

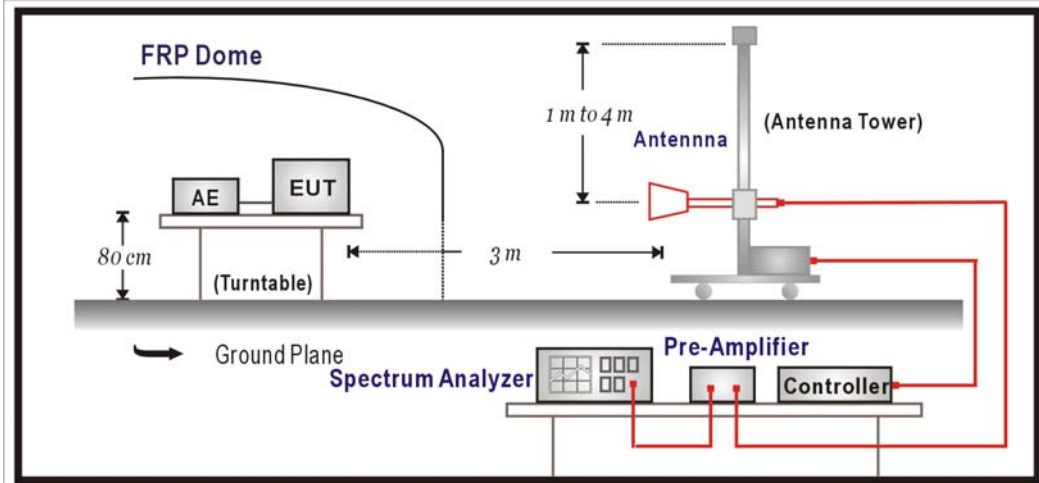

6.3. Limits

According to RSS-210 Issue 7, Annex 8 (June 2007), In any 100 kHz bandwidth outside the operating frequency bands, between 30 MHz and 5 times the carrier frequency, the unwanted emission spectral density shall be either at least 20 dB below the inband spectral density, or shall not exceed the levels specified in RSS-210 Section 6.2.1, whichever is the less stringent.

Note. For frequency hopping systems, the inband density S_i shall be measured with the hopping sequence stopped at lowest channel and highest channel in turn, as with the hopping running normally. The 20 dB shall be with reference to the lowest of the three S_i values.

RSS-210 Section 6.2.1 Limits		
Frequency MHz	uV/m @3m	dBuV/m@3m
30-88	100	40
88-216	150	43.5
216-960	200	46
Above 960	500	54

- Remarks :
1. RF Voltage (dBuV) = 20 log RF Voltage (uV)
 2. In the Above Table, the tighter limit applies at the band edges.
 3. Distance refers to the distance in meters between the measuring instrument antenna and the closed point of any part of the device or system.

6.4. Test Procedure

The EUT and its simulators are placed on a turn table which is 0.8 meter above ground. The turn table can rotate 360 degrees to determine the position of the maximum emission level. The EUT was positioned such that the distance from antenna to the EUT was 3 meters.

The antenna can move up and down between 1 meter and 4 meters to find out the maximum emission level.

Both horizontal and vertical polarization of the antenna are set on measurement. In order to find the maximum emission, all of the interface cables must be manipulated according to

ANSI C63.4: 2003 on radiated measurement.

The bandwidth below 1GHz setting on the field strength meter (R&S Test Receiver ESCS 30)is 120 kHz, above 1GHz are 1 MHz.

6.5. Uncertainty

The measurement uncertainty

Conducted is defined as $\pm 1.27\text{dB}$

Radiated is defined as $\pm 3.9\text{dB}$

6.6. Test Result

Radiated is defined as

Site : Site 1	Time : 2008/06/17 - 21:49
Limit : FCC_15.209(961011)_03M_PK	Margin : 6
Probe : CB3_FCC_1-18G(2007) - HORIZONTAL	Power :
EUT : WIRELESS G ADSL2+ MODEM ROUTER	Note : TX-2412-B

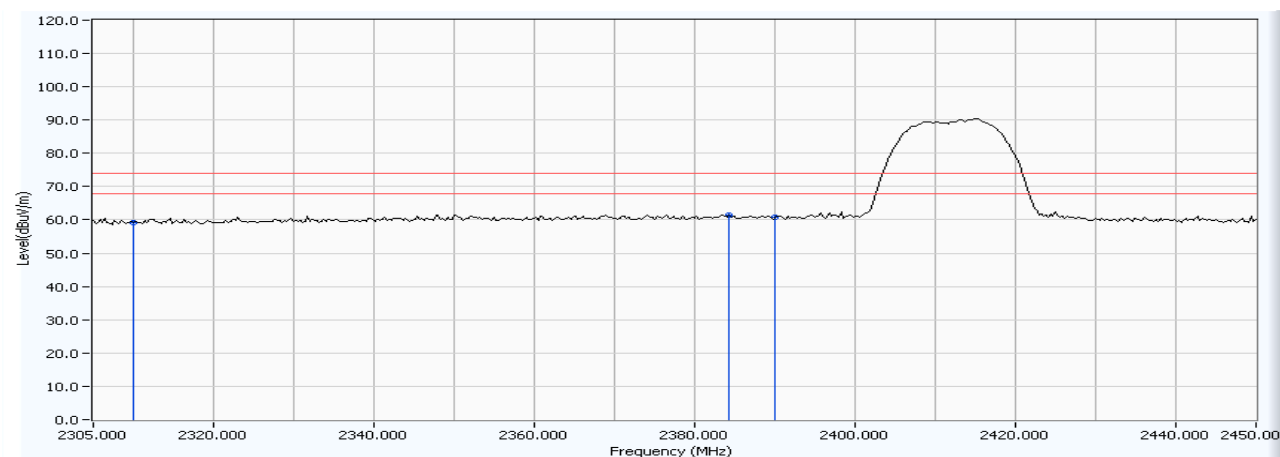

	Frequency (MHz)	Correct Factor (dB)	Reading Level (dBuV)	Measure Level (dBuV/m)	Margin (dB)	Limit (dBuV/m)	Detector Type
1	2310.000	30.412	28.925	59.336	-14.664	74.000	PEAK
2	* 2384.329	30.533	30.962	61.495	-12.505	74.000	PEAK
3	2390.000	30.543	30.127	60.670	-13.330	74.000	PEAK

Note:

1. All readings above 1GHz are performed with peak and/or average measurements as necessary.
2. Peak measurements: RBW = 1MHz, VBW = 3 MHz, Sweep: Auto.
3. Average measurements: RBW = 1MHz, VBW = 10 Hz, Sweep: Auto.
4. “ * ”, means this data is the worst emission level.
5. Measurement Level = Reading Level + Correct Factor.
6. The average measurement was not performed when the peak measured data under the limit of average detection.

Site : Site 1	Time : 2008/06/17 - 21:50
Limit : FCC_15.209(961011)_03M_AV	Margin : 6
Probe : CB3_FCC_1-18G(2007) - HORIZONTAL	Power :
EUT : WIRELESS G ADSL2+ MODEM ROUTER	Note : TX-2412-B

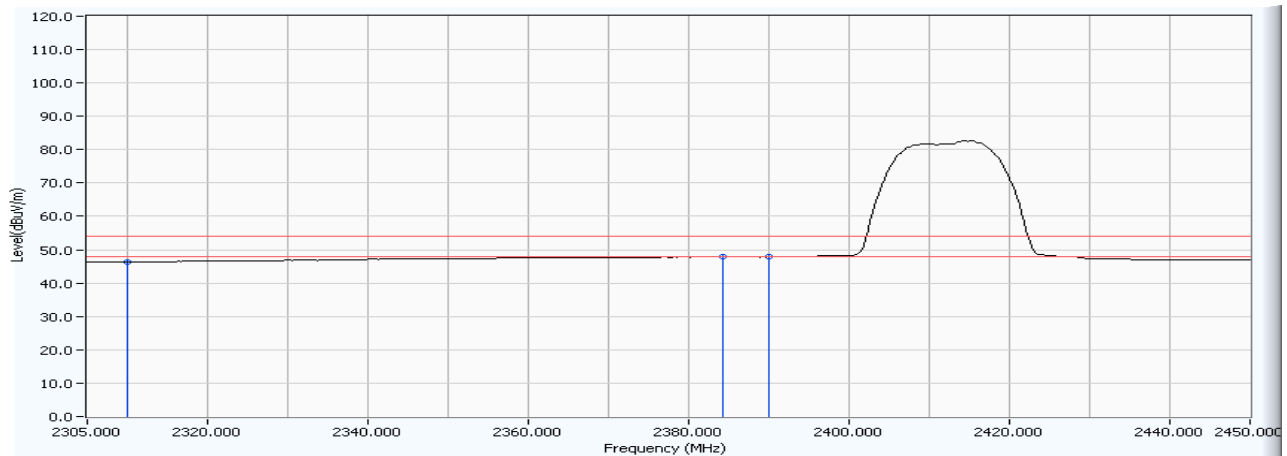

	Frequency (MHz)	Correct Factor (dB)	Reading Level (dBuV)	Measure Level (dBuV/m)	Margin (dB)	Limit (dBuV/m)	Detector Type
1	2310.000	30.412	16.001	46.412	-7.588	54.000	AVERAGE
2	* 2384.329	30.533	17.269	47.802	-6.198	54.000	AVERAGE
3	2390.000	30.543	17.251	47.794	-6.206	54.000	AVERAGE

Note:

1. All readings above 1GHz are performed with peak and/or average measurements as necessary.
2. Peak measurements: RBW = 1MHz, VBW = 3 MHz, Sweep: Auto.
3. Average measurements: RBW = 1MHz, VBW = 10 Hz, Sweep: Auto.
4. “ * ”, means this data is the worst emission level.
5. Measurement Level = Reading Level + Correct Factor.
6. The average measurement was not performed when the peak measured data under the limit of average detection.

Site : Site 1	Time : 2008/06/17 - 21:50
Limit : FCC_15.209(961011)_03M_PK	Margin : 6
Probe : CB3_FCC_1-18G(2007) - VERTICAL	Power :
EUT : WIRELESS G ADSL2+ MODEM ROUTER	Note : TX-2412-B

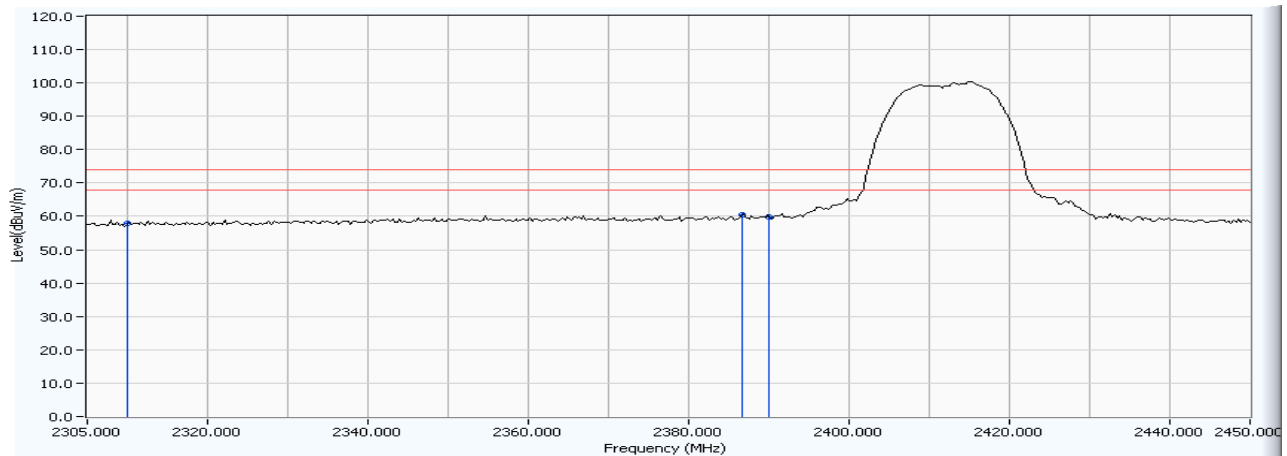

	Frequency (MHz)	Correct Factor (dB)	Reading Level (dBuV)	Measure Level (dBuV/m)	Margin (dB)	Limit (dBuV/m)	Detector Type
1	2310.000	28.433	29.375	57.808	-16.192	74.000	PEAK
2	* 2386.653	28.710	31.700	60.410	-13.590	74.000	PEAK
3	2390.000	28.724	31.257	59.981	-14.019	74.000	PEAK

Note:

1. All readings above 1GHz are performed with peak and/or average measurements as necessary.
2. Peak measurements: RBW = 1MHz, VBW = 3 MHz, Sweep: Auto.
3. Average measurements: RBW = 1MHz, VBW = 10 Hz, Sweep: Auto.
4. “ * ”, means this data is the worst emission level.
5. Measurement Level = Reading Level + Correct Factor.
6. The average measurement was not performed when the peak measured data under the limit of average detection.

Site : Site 1	Time : 2008/06/17 - 21:51
Limit : FCC_15.209(961011)_03M_AV	Margin : 6
Probe : CB3_FCC_1-18G(2007) - VERTICAL	Power :
EUT : WIRELESS G ADSL2+ MODEM ROUTER	Note : TX-2412-B

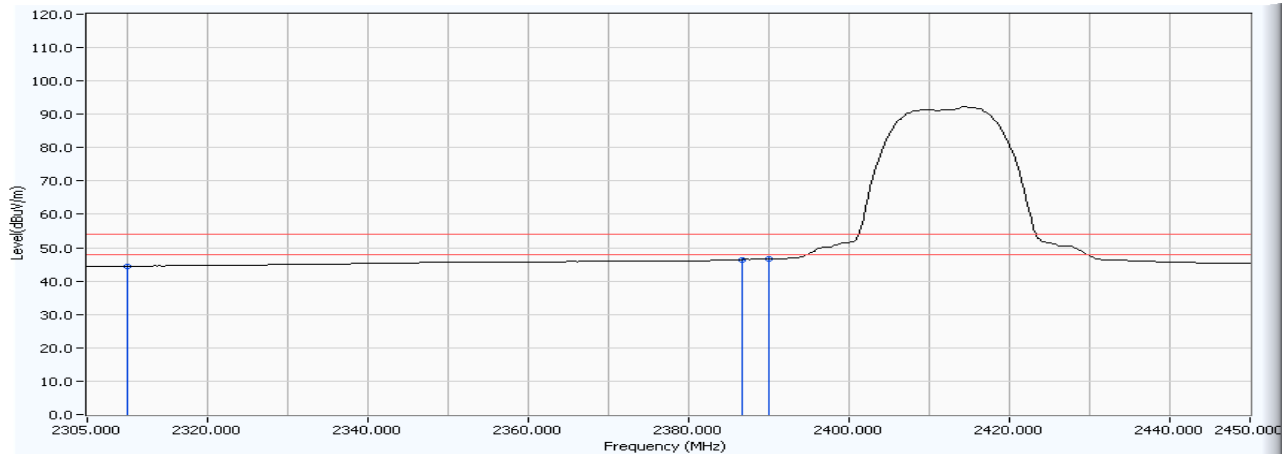

	Frequency (MHz)	Correct Factor (dB)	Reading Level (dBuV)	Measure Level (dBuV/m)	Margin (dB)	Limit (dBuV/m)	Detector Type
1	2310.000	28.433	16.083	44.516	-9.484	54.000	AVERAGE
2	* 2386.653	28.710	17.726	46.436	-7.564	54.000	AVERAGE
3	2390.000	28.724	17.923	46.647	-7.353	54.000	AVERAGE

Note:

1. All readings above 1GHz are performed with peak and/or average measurements as necessary.
2. Peak measurements: RBW = 1MHz, VBW = 3 MHz, Sweep: Auto.
3. Average measurements: RBW = 1MHz, VBW = 10 Hz, Sweep: Auto.
4. “ * ”, means this data is the worst emission level.
5. Measurement Level = Reading Level + Correct Factor.
6. The average measurement was not performed when the peak measured data under the limit of average detection.

Site : Site 1	Time : 2008/06/17 - 21:56
Limit : FCC_15.209(961011)_03M_PK	Margin : 6
Probe : CB3_FCC_1-18G(2007) - HORIZONTAL	Power :
EUT : WIRELESS G ADSL2+ MODEM ROUTER	Note : TX-2462-B

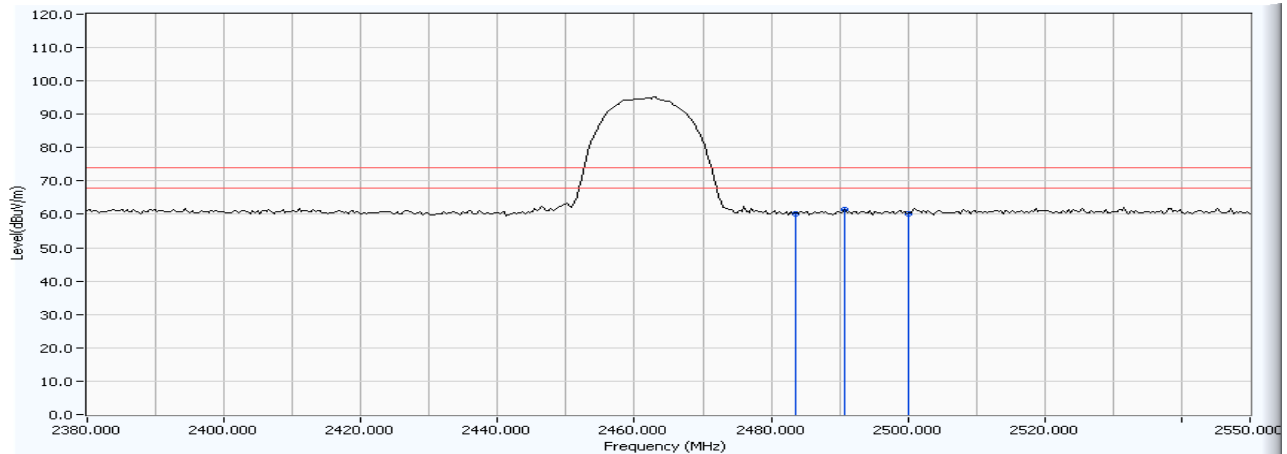

	Frequency (MHz)	Correct Factor (dB)	Reading Level (dBuV)	Measure Level (dBuV/m)	Margin (dB)	Limit (dBuV/m)	Detector Type
1	2483.500	30.696	29.618	60.313	-13.687	74.000	PEAK
2	* 2490.721	30.704	30.586	61.290	-12.710	74.000	PEAK
3	2500.000	30.722	29.587	60.309	-13.691	74.000	PEAK

Note:

1. All readings above 1GHz are performed with peak and/or average measurements as necessary.
2. Peak measurements: RBW = 1MHz, VBW = 3 MHz, Sweep: Auto.
3. Average measurements: RBW = 1MHz, VBW = 10 Hz, Sweep: Auto.
4. “ * ”, means this data is the worst emission level.
5. Measurement Level = Reading Level + Correct Factor.
6. The average measurement was not performed when the peak measured data under the limit of average detection.

Site : Site 1	Time : 2008/06/17 - 21:58
Limit : FCC_15.209(961011)_03M_AV	Margin : 6
Probe : CB3_FCC_1-18G(2007) - HORIZONTAL	Power :
EUT : WIRELESS G ADSL2+ MODEM ROUTER	Note : TX-2462-B

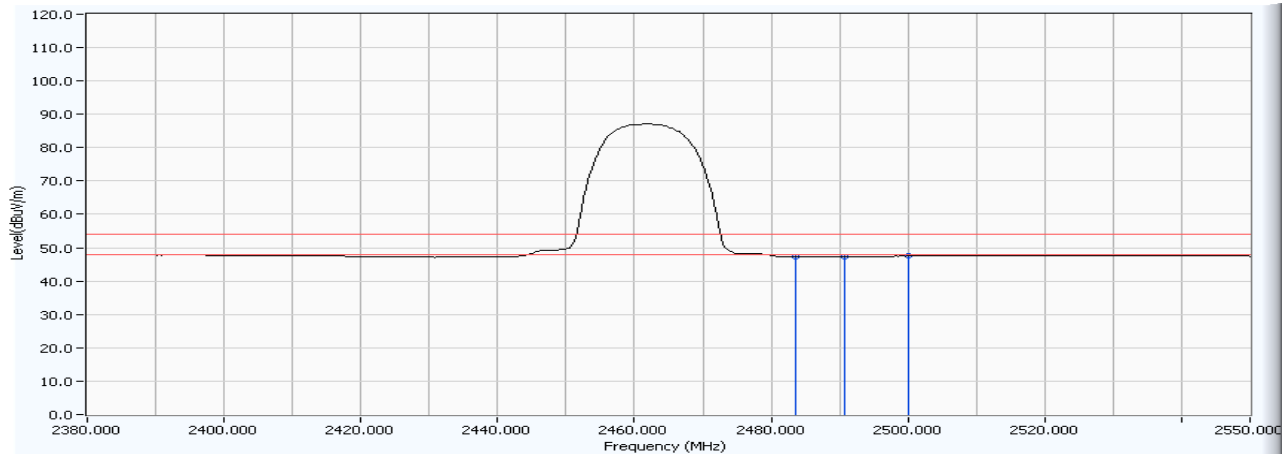

	Frequency (MHz)	Correct Factor (dB)	Reading Level (dBuV)	Measure Level (dBuV/m)	Margin (dB)	Limit (dBuV/m)	Detector Type
1	2483.500	30.696	16.610	47.305	-6.695	54.000	AVERAGE
2	* 2490.721	30.704	16.707	47.411	-6.589	54.000	AVERAGE
3	2500.000	30.722	16.752	47.474	-6.526	54.000	AVERAGE

Note:

1. All readings above 1GHz are performed with peak and/or average measurements as necessary.
2. Peak measurements: RBW = 1MHz, VBW = 3 MHz, Sweep: Auto.
3. Average measurements: RBW = 1MHz, VBW = 10 Hz, Sweep: Auto.
4. “ * ”, means this data is the worst emission level.
5. Measurement Level = Reading Level + Correct Factor.
6. The average measurement was not performed when the peak measured data under the limit of average detection.

Site : Site 1	Time : 2008/06/17 - 21:59
Limit : FCC_15.209(961011)_03M_PK	Margin : 6
Probe : CB3_FCC_1-18G(2007) - VERTICAL	Power :
EUT : WIRELESS G ADSL2+ MODEM ROUTER	Note : TX-2462-B

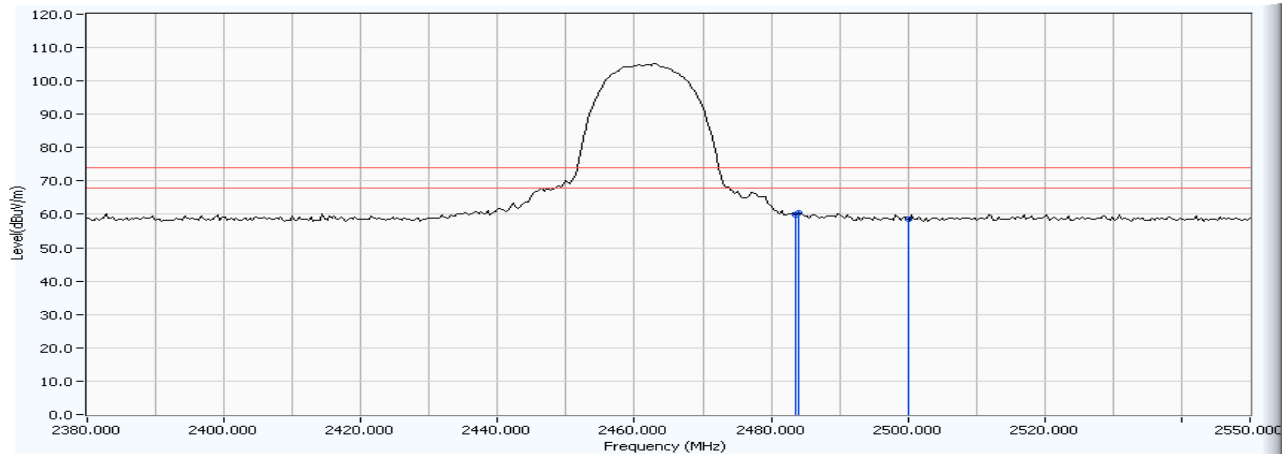

	Frequency (MHz)	Correct Factor (dB)	Reading Level (dBuV)	Measure Level (dBuV/m)	Margin (dB)	Limit (dBuV/m)	Detector Type
1	2483.500	29.064	30.854	59.917	-14.083	74.000	PEAK
2	* 2483.908	29.065	31.310	60.374	-13.626	74.000	PEAK
3	2500.000	29.114	29.293	58.407	-15.593	74.000	PEAK

Note:

1. All readings above 1GHz are performed with peak and/or average measurements as necessary.
2. Peak measurements: RBW = 1MHz, VBW = 3 MHz, Sweep: Auto.
3. Average measurements: RBW = 1MHz, VBW = 10 Hz, Sweep: Auto.
4. “ * ”, means this data is the worst emission level.
5. Measurement Level = Reading Level + Correct Factor.
6. The average measurement was not performed when the peak measured data under the limit of average detection.

Site : Site 1	Time : 2008/06/17 - 21:59
Limit : FCC_15.209(961011)_03M_AV	Margin : 6
Probe : CB3_FCC_1-18G(2007) - VERTICAL	Power :
EUT : WIRELESS G ADSL2+ MODEM ROUTER	Note : TX-2462-B

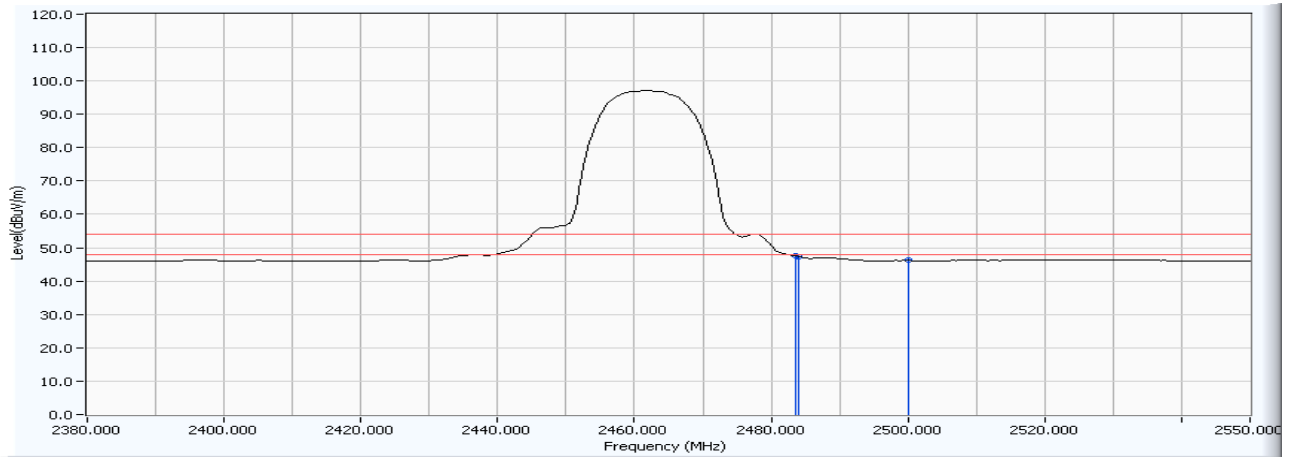

	Frequency (MHz)	Correct Factor (dB)	Reading Level (dBuV)	Measure Level (dBuV/m)	Margin (dB)	Limit (dBuV/m)	Detector Type
1	2483.500	29.064	18.435	47.498	-6.502	54.000	AVERAGE
2	* 2483.903	29.065	18.278	47.342	-6.658	54.000	AVERAGE
3	2500.000	29.114	17.069	46.183	-7.817	54.000	AVERAGE

Note:

1. All readings above 1GHz are performed with peak and/or average measurements as necessary.
2. Peak measurements: RBW = 1MHz, VBW = 3 MHz, Sweep: Auto.
3. Average measurements: RBW = 1MHz, VBW = 10 Hz, Sweep: Auto.
4. “ * ”, means this data is the worst emission level.
5. Measurement Level = Reading Level + Correct Factor.
6. The average measurement was not performed when the peak measured data under the limit of average detection.

Site : Site 1	Time : 2008/06/17 - 22:12
Limit : FCC_15.209(961011)_03M_PK	Margin : 6
Probe : CB3_FCC_1-18G(2007) - HORIZONTAL	Power :
EUT : WIRELESS G ADSL2+ MODEM ROUTER	Note : TX-2412-G

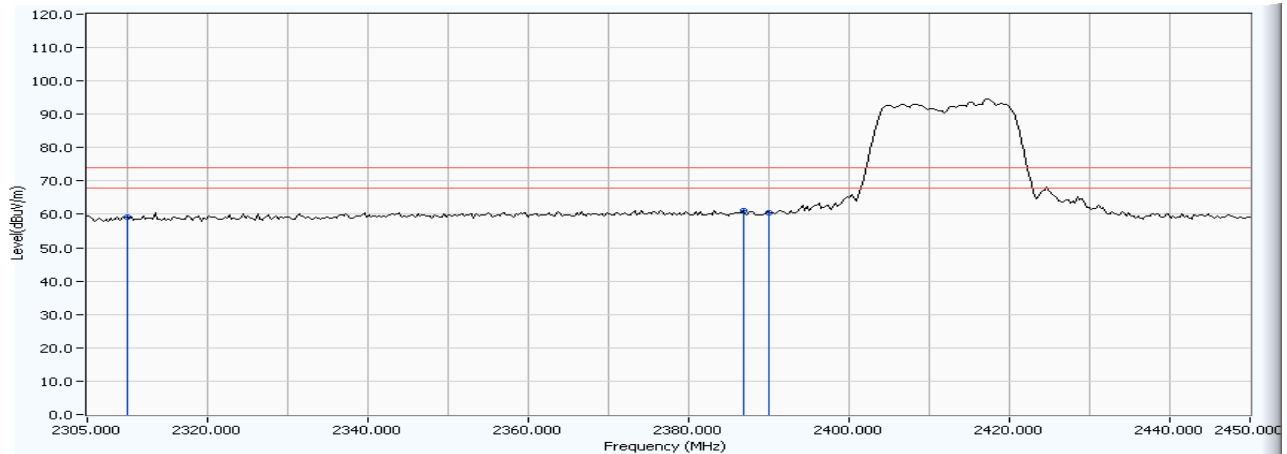

	Frequency (MHz)	Correct Factor (dB)	Reading Level (dBuV)	Measure Level (dBuV/m)	Margin (dB)	Limit (dBuV/m)	Detector Type
1	2310.000	30.412	28.740	59.151	-14.849	74.000	PEAK
2	* 2386.944	30.538	30.716	61.254	-12.746	74.000	PEAK
3	2390.000	30.543	30.066	60.609	-13.391	74.000	PEAK

Note:

1. All readings above 1GHz are performed with peak and/or average measurements as necessary.
2. Peak measurements: RBW = 1MHz, VBW = 3 MHz, Sweep: Auto.
3. Average measurements: RBW = 1MHz, VBW = 10 Hz, Sweep: Auto.
4. “ * ”, means this data is the worst emission level.
5. Measurement Level = Reading Level + Correct Factor.
6. The average measurement was not performed when the peak measured data under the limit of average detection.

Site : Site 1	Time : 2008/06/17 - 22:14
Limit : FCC_15.209(961011)_03M_AV	Margin : 6
Probe : CB3_FCC_1-18G(2007) - HORIZONTAL	Power :
EUT : WIRELESS G ADSL2+ MODEM ROUTER	Note : TX-2412-G

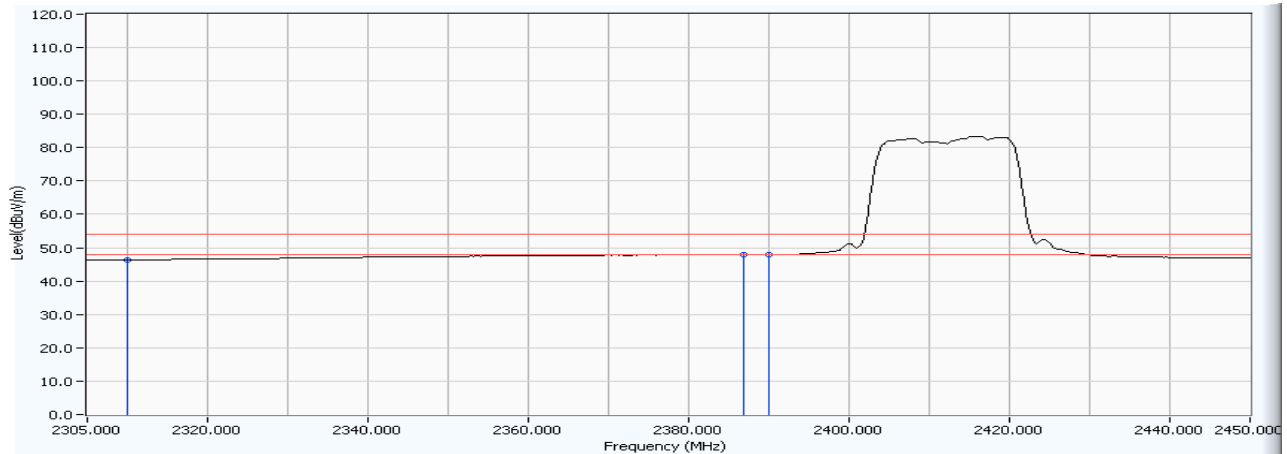

	Frequency (MHz)	Correct Factor (dB)	Reading Level (dBuV)	Measure Level (dBuV/m)	Margin (dB)	Limit (dBuV/m)	Detector Type
1	2310.000	30.412	16.013	46.424	-7.576	54.000	AVERAGE
2	* 2386.944	30.538	17.360	47.898	-6.102	54.000	AVERAGE
3	2390.000	30.543	17.366	47.909	-6.091	54.000	AVERAGE

Note:

1. All readings above 1GHz are performed with peak and/or average measurements as necessary.
2. Peak measurements: RBW = 1MHz, VBW = 3 MHz, Sweep: Auto.
3. Average measurements: RBW = 1MHz, VBW = 10 Hz, Sweep: Auto.
4. “ * ”, means this data is the worst emission level.
5. Measurement Level = Reading Level + Correct Factor.
6. The average measurement was not performed when the peak measured data under the limit of average detection.

Site : Site 1	Time : 2008/06/17 - 22:18
Limit : FCC_15.209(961011)_03M_PK	Margin : 6
Probe : CB3_FCC_1-18G(2007) - VERTICAL	Power :
EUT : WIRELESS G ADSL2+ MODEM ROUTER	Note : TX-2412-G

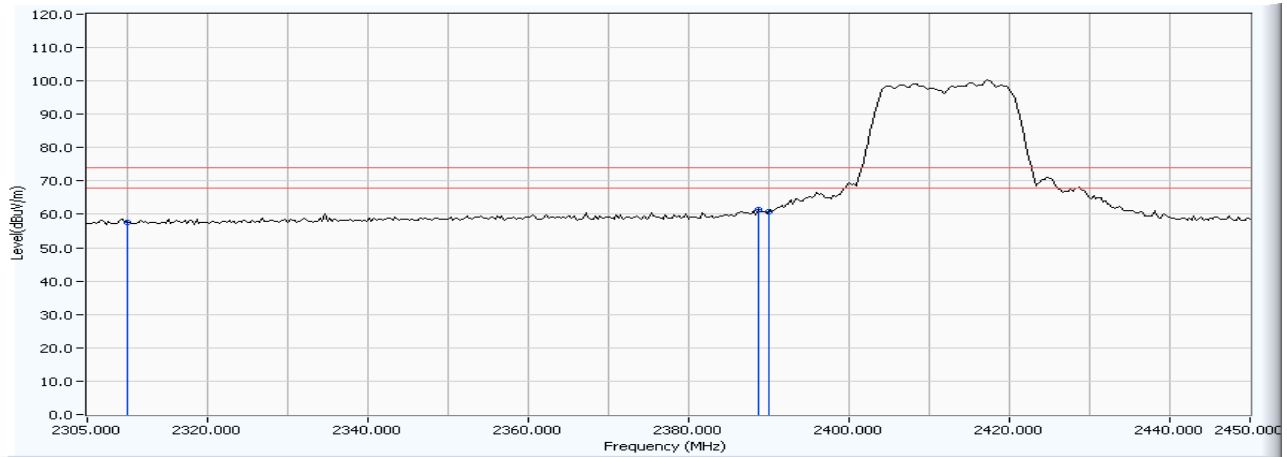

	Frequency (MHz)	Correct Factor (dB)	Reading Level (dBuV)	Measure Level (dBuV/m)	Margin (dB)	Limit (dBuV/m)	Detector Type
1	2310.000	28.433	29.222	57.655	-16.345	74.000	PEAK
2	* 2388.687	28.718	32.699	61.417	-12.583	74.000	PEAK
3	2390.000	28.724	32.157	60.881	-13.119	74.000	PEAK

Note:

1. All readings above 1GHz are performed with peak and/or average measurements as necessary.
2. Peak measurements: RBW = 1MHz, VBW = 3 MHz, Sweep: Auto.
3. Average measurements: RBW = 1MHz, VBW = 10 Hz, Sweep: Auto.
4. “ * ”, means this data is the worst emission level.
5. Measurement Level = Reading Level + Correct Factor.
6. The average measurement was not performed when the peak measured data under the limit of average detection.

Site : Site 1	Time : 2008/06/17 - 22:20
Limit : FCC_15.209(961011)_03M_AV	Margin : 6
Probe : CB3_FCC_1-18G(2007) - VERTICAL	Power :
EUT : WIRELESS G ADSL2+ MODEM ROUTER	Note : TX-2412-G

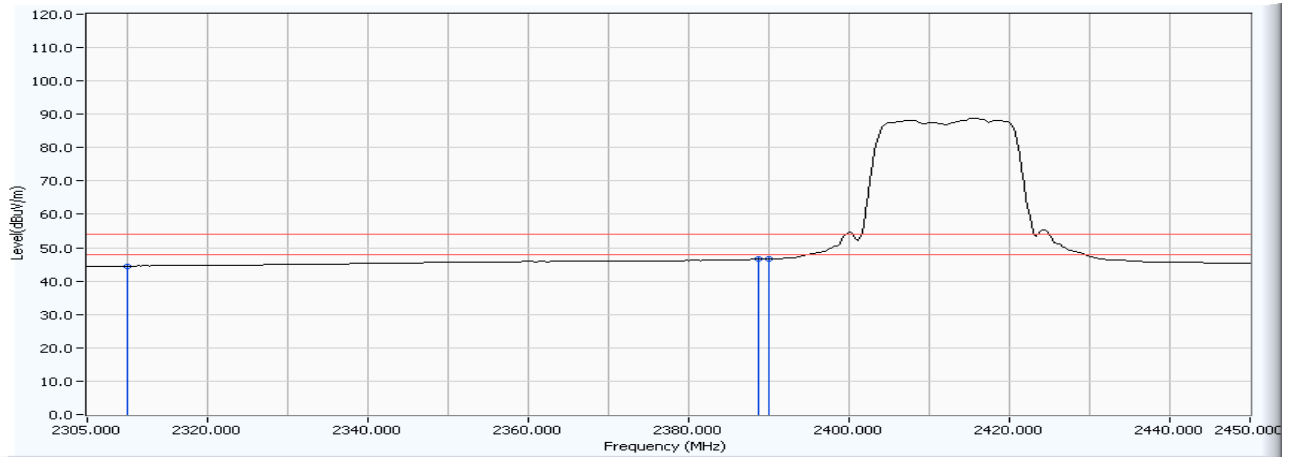

	Frequency (MHz)	Correct Factor (dB)	Reading Level (dBuV)	Measure Level (dBuV/m)	Margin (dB)	Limit (dBuV/m)	Detector Type
1	2310.000	28.433	16.118	44.551	-9.449	54.000	AVERAGE
2	* 2388.687	28.718	17.832	46.550	-7.450	54.000	AVERAGE
3	2390.000	28.724	17.901	46.625	-7.375	54.000	AVERAGE

Note:

1. All readings above 1GHz are performed with peak and/or average measurements as necessary.
2. Peak measurements: RBW = 1MHz, VBW = 3 MHz, Sweep: Auto.
3. Average measurements: RBW = 1MHz, VBW = 10 Hz, Sweep: Auto.
4. “ * ”, means this data is the worst emission level.
5. Measurement Level = Reading Level + Correct Factor.
6. The average measurement was not performed when the peak measured data under the limit of average detection.

Site : Site 1	Time : 2008/06/17 - 22:00
Limit : FCC_15.209(961011)_03M_PK	Margin : 6
Probe : CB3_FCC_1-18G(2007) - HORIZONTAL	Power :
EUT : WIRELESS G ADSL2+ MODEM ROUTER	Note : TX-2462-G

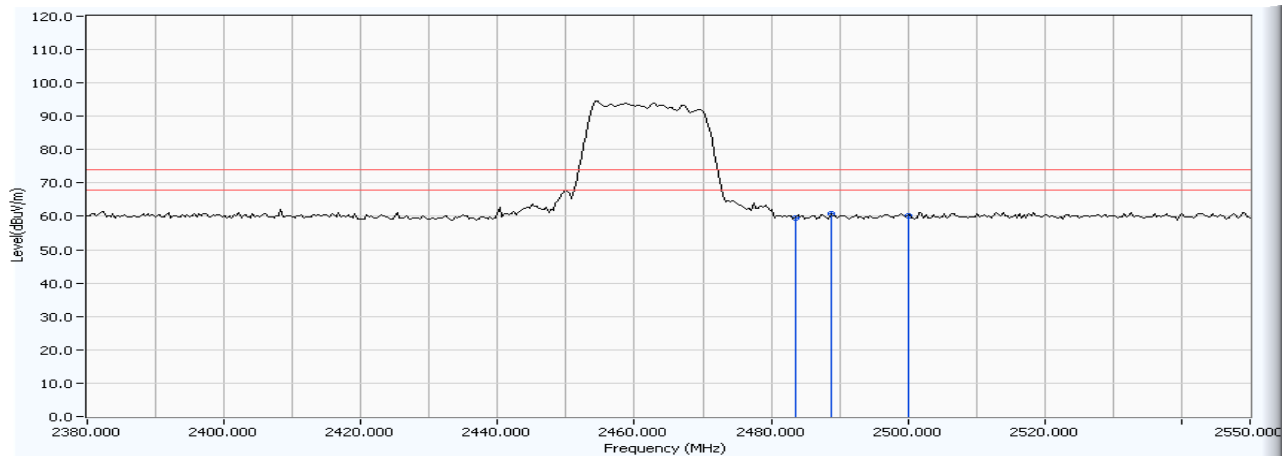

	Frequency (MHz)	Correct Factor (dB)	Reading Level (dBuV)	Measure Level (dBuV/m)	Margin (dB)	Limit (dBuV/m)	Detector Type
1	2483.500	30.696	28.962	59.657	-14.343	74.000	PEAK
2	* 2488.677	30.702	30.208	60.909	-13.091	74.000	PEAK
3	2500.000	30.722	29.521	60.243	-13.757	74.000	PEAK

Note:

1. All readings above 1GHz are performed with peak and/or average measurements as necessary.
2. Peak measurements: RBW = 1MHz, VBW = 3 MHz, Sweep: Auto.
3. Average measurements: RBW = 1MHz, VBW = 10 Hz, Sweep: Auto.
4. “ * ”, means this data is the worst emission level.
5. Measurement Level = Reading Level + Correct Factor.
6. The average measurement was not performed when the peak measured data under the limit of average detection.

Site : Site 1	Time : 2008/06/17 - 22:02
Limit : FCC_15.209(961011)_03M_AV	Margin : 6
Probe : CB3_FCC_1-18G(2007) - HORIZONTAL	Power :
EUT : WIRELESS G ADSL2+ MODEM ROUTER	Note : TX-2462-G

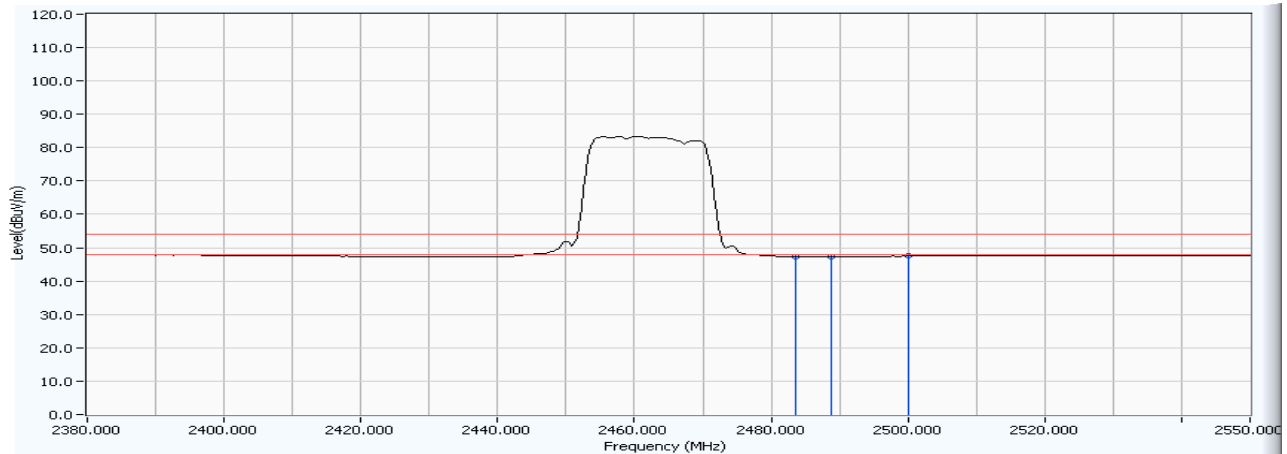

	Frequency (MHz)	Correct Factor (dB)	Reading Level (dBuV)	Measure Level (dBuV/m)	Margin (dB)	Limit (dBuV/m)	Detector Type
1	2483.500	30.696	16.602	47.297	-6.703	54.000	AVERAGE
2	* 2488.677	30.702	16.673	47.374	-6.626	54.000	AVERAGE
3	2500.000	30.722	16.759	47.481	-6.519	54.000	AVERAGE

Note:

1. All readings above 1GHz are performed with peak and/or average measurements as necessary.
2. Peak measurements: RBW = 1MHz, VBW = 3 MHz, Sweep: Auto.
3. Average measurements: RBW = 1MHz, VBW = 10 Hz, Sweep: Auto.
4. “ * ”, means this data is the worst emission level.
5. Measurement Level = Reading Level + Correct Factor.
6. The average measurement was not performed when the peak measured data under the limit of average detection.

Site : Site 1	Time : 2008/06/17 - 22:03
Limit : FCC_15.209(961011)_03M_PK	Margin : 6
Probe : CB3_FCC_1-18G(2007) - VERTICAL	Power :
EUT : WIRELESS G ADSL2+ MODEM ROUTER	Note : TX-2462-G

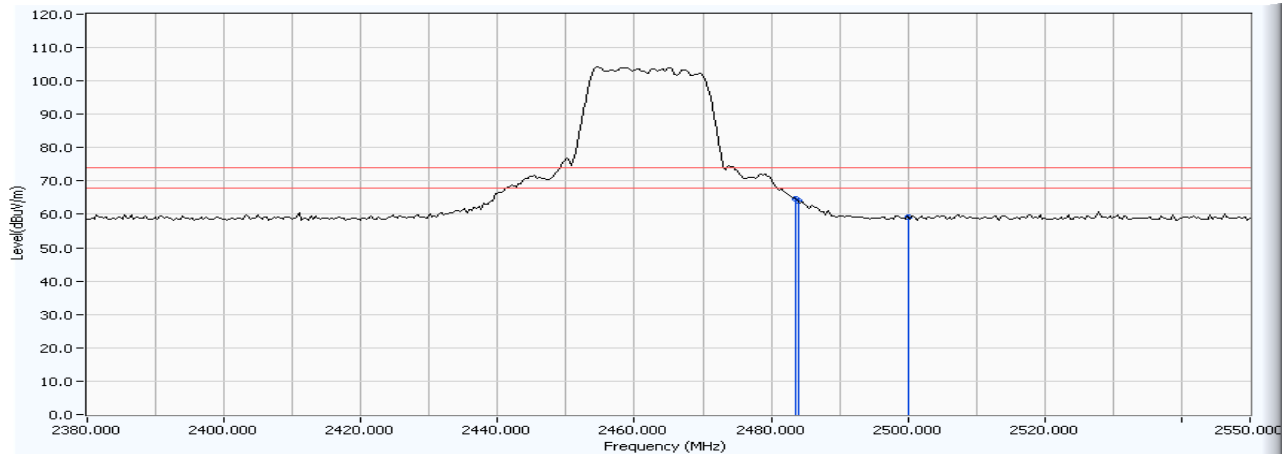

	Frequency (MHz)	Correct Factor (dB)	Reading Level (dBuV)	Measure Level (dBuV/m)	Margin (dB)	Limit (dBuV/m)	Detector Type
1	2483.500	29.064	35.690	64.753	-9.247	74.000	PEAK
2	* 2483.908	29.065	34.849	63.913	-10.087	74.000	PEAK
3	2500.000	29.114	30.099	59.213	-14.787	74.000	PEAK

Note:

1. All readings above 1GHz are performed with peak and/or average measurements as necessary.
2. Peak measurements: RBW = 1MHz, VBW = 3 MHz, Sweep: Auto.
3. Average measurements: RBW = 1MHz, VBW = 10 Hz, Sweep: Auto.
4. “ * ”, means this data is the worst emission level.
5. Measurement Level = Reading Level + Correct Factor.
6. The average measurement was not performed when the peak measured data under the limit of average detection.

Site : Site 1	Time : 2008/06/17 - 22:03
Limit : FCC_15.209(961011)_03M_AV	Margin : 6
Probe : CB3_FCC_1-18G(2007) - VERTICAL	Power :
EUT : WIRELESS G ADSL2+ MODEM ROUTER	Note : TX-2462-G

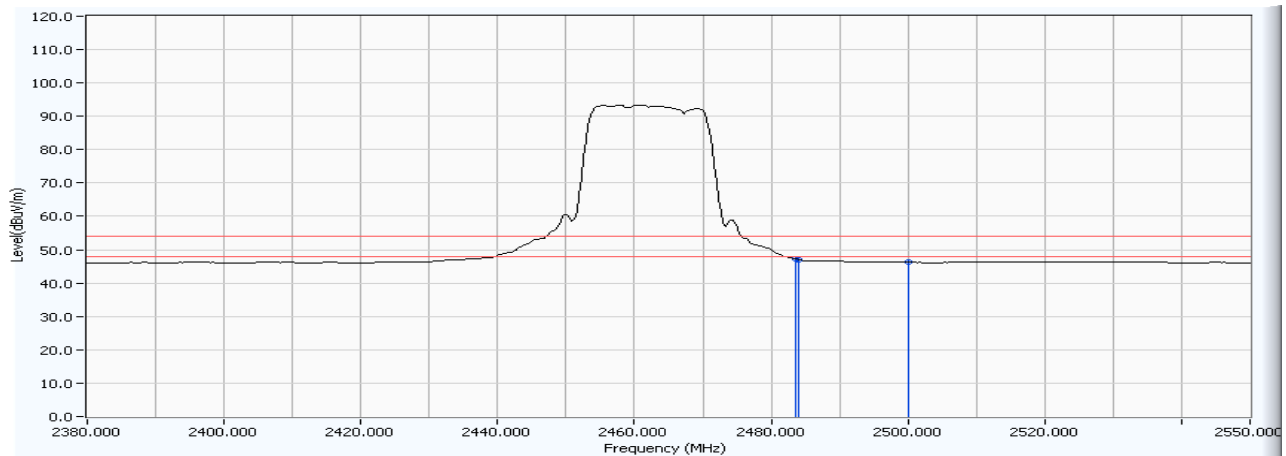

	Frequency (MHz)	Correct Factor (dB)	Reading Level (dBuV)	Measure Level (dBuV/m)	Margin (dB)	Limit (dBuV/m)	Detector Type
1	2483.500	29.064	18.259	47.322	-6.678	54.000	AVERAGE
2	* 2483.908	29.065	17.993	47.057	-6.943	54.000	AVERAGE
3	2500.000	29.114	17.124	46.238	-7.762	54.000	AVERAGE

Note:

1. All readings above 1GHz are performed with peak and/or average measurements as necessary.
2. Peak measurements: RBW = 1MHz, VBW = 3 MHz, Sweep: Auto.
3. Average measurements: RBW = 1MHz, VBW = 10 Hz, Sweep: Auto.
4. “ * ”, means this data is the worst emission level.
5. Measurement Level = Reading Level + Correct Factor.
6. The average measurement was not performed when the peak measured data under the limit of average detection.

Site : Site 1	Time : 2008/06/17 - 22:34
Limit : FCC_15.209(961011)_03M_PK	Margin : 6
Probe : CB3_FCC_1-18G(2007) - HORIZONTAL	Power :
EUT : WIRELESS G ADSL2+ MODEM ROUTER	Note : TX-2412-N(20M)

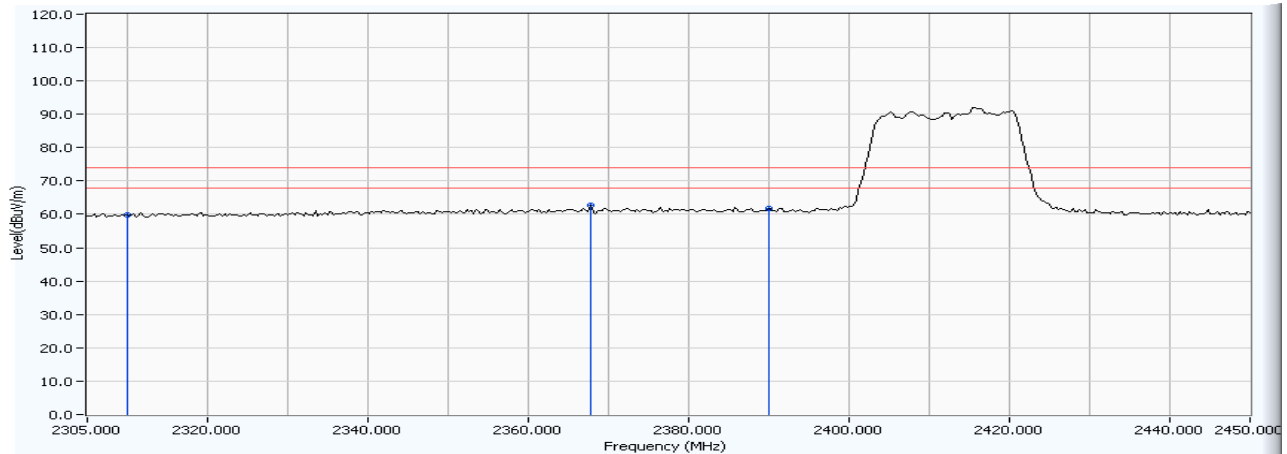

	Frequency (MHz)	Correct Factor (dB)	Reading Level (dBuV)	Measure Level (dBuV/m)	Margin (dB)	Limit (dBuV/m)	Detector Type
1	2310.000	30.412	29.451	59.862	-14.138	74.000	PEAK
2	* 2367.766	30.504	32.386	62.890	-11.110	74.000	PEAK
3	2390.000	30.543	31.120	61.663	-12.337	74.000	PEAK

Note:

1. All readings above 1GHz are performed with peak and/or average measurements as necessary.
2. Peak measurements: RBW = 1MHz, VBW = 3 MHz, Sweep: Auto.
3. Average measurements: RBW = 1MHz, VBW = 10 Hz, Sweep: Auto.
4. “ * ”, means this data is the worst emission level.
5. Measurement Level = Reading Level + Correct Factor.
6. The average measurement was not performed when the peak measured data under the limit of average detection.

Site : Site 1	Time : 2008/06/17 - 22:38
Limit : FCC_15.209(961011)_03M_AV	Margin : 6
Probe : CB3_FCC_1-18G(2007) - HORIZONTAL	Power :
EUT : WIRELESS G ADSL2+ MODEM ROUTER	Note : TX-2412-N(20M)

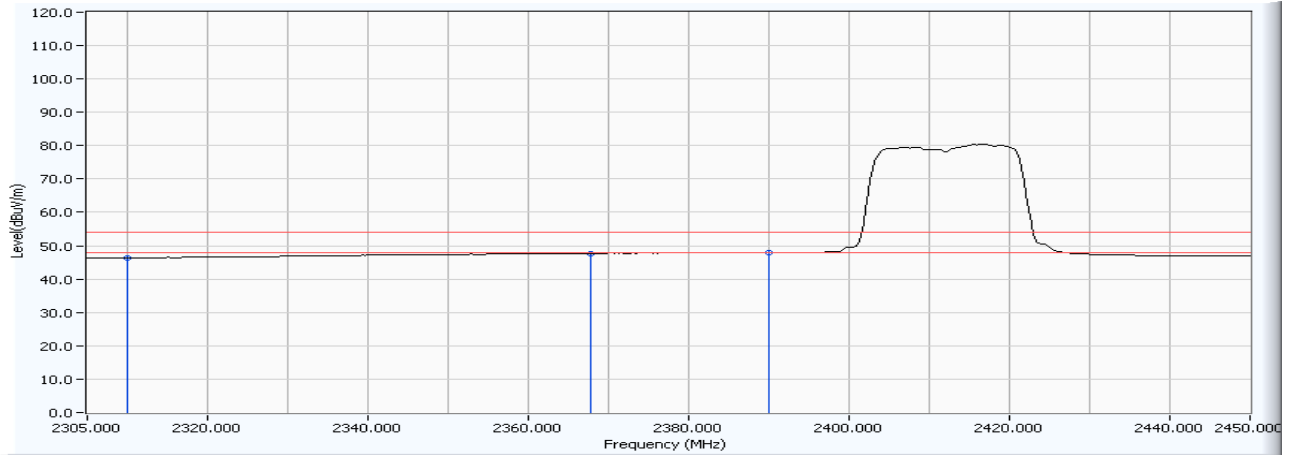

	Frequency (MHz)	Correct Factor (dB)	Reading Level (dBuV)	Measure Level (dBuV/m)	Margin (dB)	Limit (dBuV/m)	Detector Type
1	2310.000	30.412	16.006	46.417	-7.583	54.000	AVERAGE
2	* 2367.766	30.504	17.216	47.720	-6.280	54.000	AVERAGE
3	2390.000	30.543	17.275	47.818	-6.182	54.000	AVERAGE

Note:

1. All readings above 1GHz are performed with peak and/or average measurements as necessary.
2. Peak measurements: RBW = 1MHz, VBW = 3 MHz, Sweep: Auto.
3. Average measurements: RBW = 1MHz, VBW = 10 Hz, Sweep: Auto.
4. “ * ”, means this data is the worst emission level.
5. Measurement Level = Reading Level + Correct Factor.
6. The average measurement was not performed when the peak measured data under the limit of average detection.

Site : Site 1	Time : 2008/06/17 - 22:44
Limit : FCC_15.209(961011)_03M_PK	Margin : 6
Probe : CB3_FCC_1-18G(2007) - VERTICAL	Power :
EUT : WIRELESS G ADSL2+ MODEM ROUTER	Note : TX-2412-N(20M)

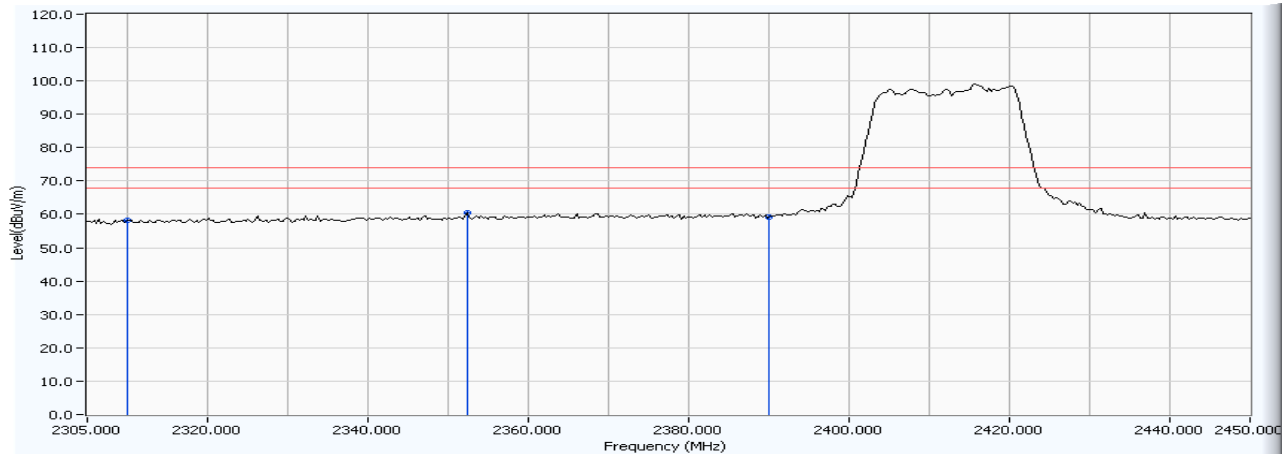

	Frequency (MHz)	Correct Factor (dB)	Reading Level (dBuV)	Measure Level (dBuV/m)	Margin (dB)	Limit (dBuV/m)	Detector Type
1	2310.000	28.433	29.843	58.276	-15.724	74.000	PEAK
2	* 2352.365	28.583	31.959	60.542	-13.458	74.000	PEAK
3	2390.000	28.724	30.588	59.312	-14.688	74.000	PEAK

Note:

1. All readings above 1GHz are performed with peak and/or average measurements as necessary.
2. Peak measurements: RBW = 1MHz, VBW = 3 MHz, Sweep: Auto.
3. Average measurements: RBW = 1MHz, VBW = 10 Hz, Sweep: Auto.
4. “ * ”, means this data is the worst emission level.
5. Measurement Level = Reading Level + Correct Factor.
6. The average measurement was not performed when the peak measured data under the limit of average detection.

Site : Site 1	Time : 2008/06/17 - 22:45
Limit : FCC_15.209(961011)_03M_AV	Margin : 6
Probe : CB3_FCC_1-18G(2007) - VERTICAL	Power :
EUT : WIRELESS G ADSL2+ MODEM ROUTER	Note : TX-2412-N(20M)

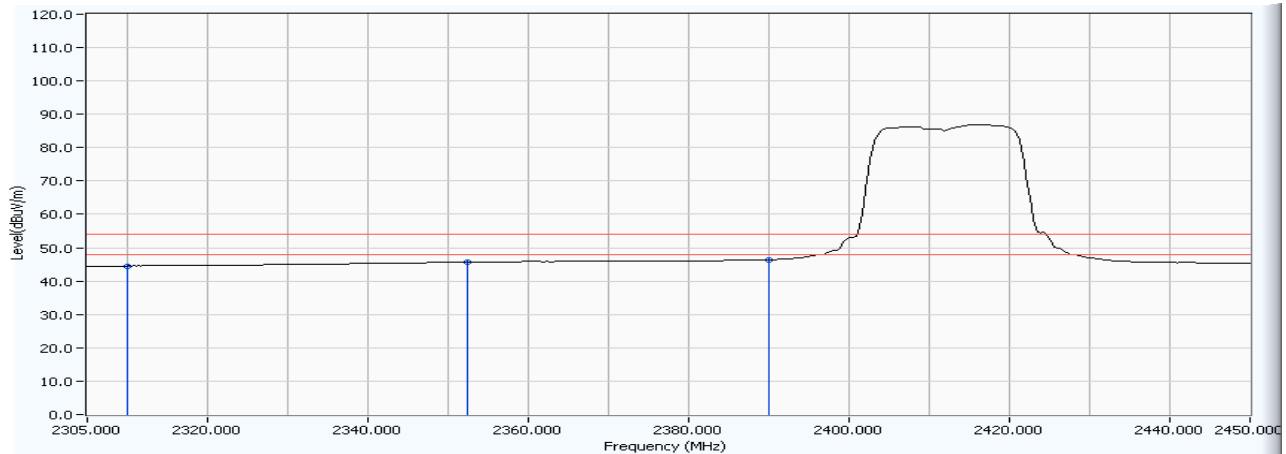

	Frequency (MHz)	Correct Factor (dB)	Reading Level (dBuV)	Measure Level (dBuV/m)	Margin (dB)	Limit (dBuV/m)	Detector Type
1	2310.000	28.433	16.112	44.545	-9.455	54.000	AVERAGE
2	* 2352.356	28.583	17.083	45.666	-8.334	54.000	AVERAGE
3	2390.000	28.724	17.704	46.428	-7.572	54.000	AVERAGE

Note:

1. All readings above 1GHz are performed with peak and/or average measurements as necessary.
2. Peak measurements: RBW = 1MHz, VBW = 3 MHz, Sweep: Auto.
3. Average measurements: RBW = 1MHz, VBW = 10 Hz, Sweep: Auto.
4. “ * ”, means this data is the worst emission level.
5. Measurement Level = Reading Level + Correct Factor.
6. The average measurement was not performed when the peak measured data under the limit of average detection.

Site : Site 1	Time : 2008/06/17 - 22:56
Limit : FCC_15.209(961011)_03M_PK	Margin : 6
Probe : CB3_FCC_1-18G(2007) - HORIZONTAL	Power :
EUT : WIRELESS G ADSL2+ MODEM ROUTER	Note : TX-2462-N(20M)

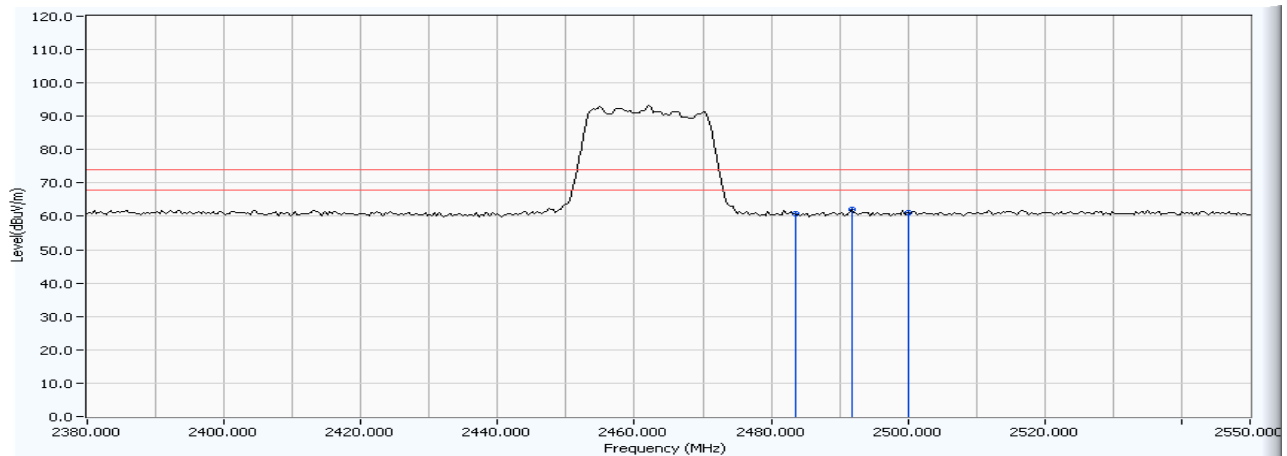

	Frequency (MHz)	Correct Factor (dB)	Reading Level (dBuV)	Measure Level (dBuV/m)	Margin (dB)	Limit (dBuV/m)	Detector Type
1	2483.500	30.696	29.952	60.647	-13.353	74.000	PEAK
2	* 2491.743	30.704	31.475	62.180	-11.820	74.000	PEAK
3	2500.000	30.722	30.435	61.157	-12.843	74.000	PEAK

Note:

1. All readings above 1GHz are performed with peak and/or average measurements as necessary.
2. Peak measurements: RBW = 1MHz, VBW = 3 MHz, Sweep: Auto.
3. Average measurements: RBW = 1MHz, VBW = 10 Hz, Sweep: Auto.
4. “ * ”, means this data is the worst emission level.
5. Measurement Level = Reading Level + Correct Factor.
6. The average measurement was not performed when the peak measured data under the limit of average detection.

Site : Site 1	Time : 2008/06/17 - 22:58
Limit : FCC_15.209(961011)_03M_AV	Margin : 6
Probe : CB3_FCC_1-18G(2007) - HORIZONTAL	Power :
EUT : WIRELESS G ADSL2+ MODEM ROUTER	Note : TX-2462-N(20M)

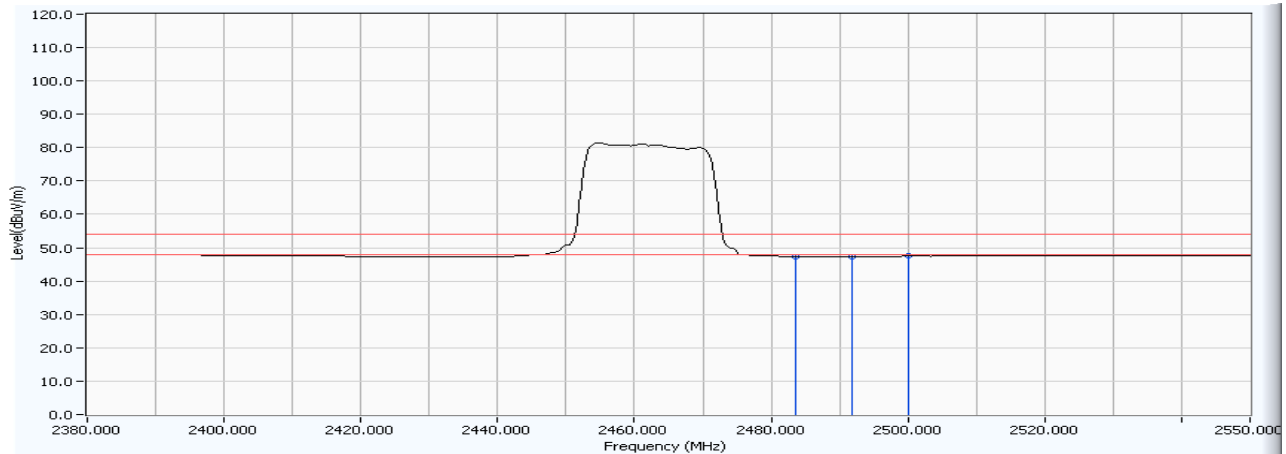

	Frequency (MHz)	Correct Factor (dB)	Reading Level (dBuV)	Measure Level (dBuV/m)	Margin (dB)	Limit (dBuV/m)	Detector Type
1	2483.500	30.696	16.651	47.346	-6.654	54.000	AVERAGE
2	* 2491.743	30.704	16.683	47.388	-6.612	54.000	AVERAGE
3	2500.000	30.722	16.758	47.480	-6.520	54.000	AVERAGE

Note:

1. All readings above 1GHz are performed with peak and/or average measurements as necessary.
2. Peak measurements: RBW = 1MHz, VBW = 3 MHz, Sweep: Auto.
3. Average measurements: RBW = 1MHz, VBW = 10 Hz, Sweep: Auto.
4. “ * ”, means this data is the worst emission level.
5. Measurement Level = Reading Level + Correct Factor.
6. The average measurement was not performed when the peak measured data under the limit of average detection.

Site : Site 1	Time : 2008/06/17 - 23:03
Limit : FCC_15.209(961011)_03M_PK	Margin : 6
Probe : CB3_FCC_1-18G(2007) - VERTICAL	Power :
EUT : WIRELESS G ADSL2+ MODEM ROUTER	Note : TX-2462-N(20M)

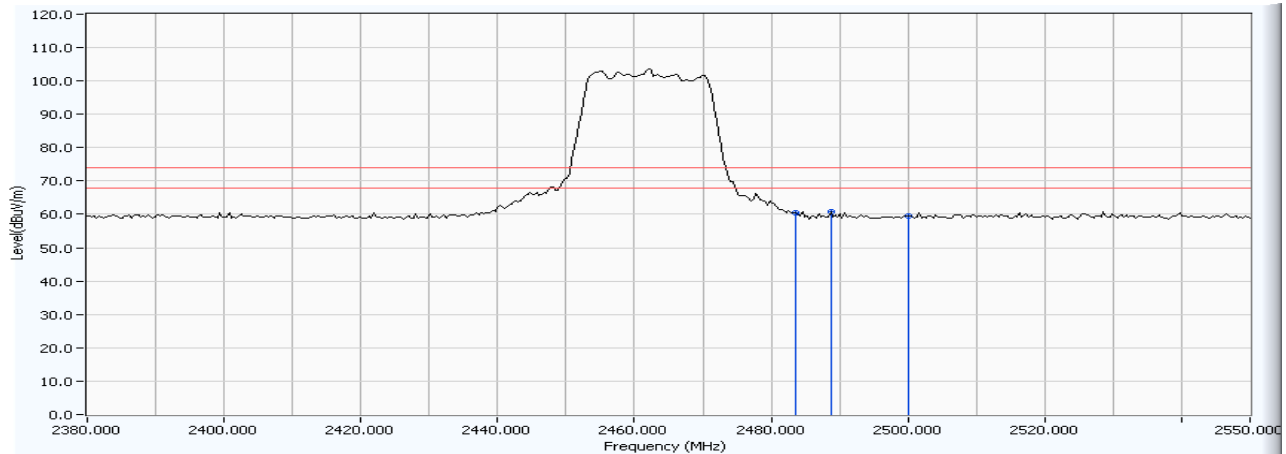

	Frequency (MHz)	Correct Factor (dB)	Reading Level (dBuV)	Measure Level (dBuV/m)	Margin (dB)	Limit (dBuV/m)	Detector Type
1	2483.500	29.064	31.458	60.521	-13.479	74.000	PEAK
2	* 2488.677	29.079	31.672	60.750	-13.250	74.000	PEAK
3	2500.000	29.114	30.306	59.420	-14.580	74.000	PEAK

Note:

1. All readings above 1GHz are performed with peak and/or average measurements as necessary.
2. Peak measurements: RBW = 1MHz, VBW = 3 MHz, Sweep: Auto.
3. Average measurements: RBW = 1MHz, VBW = 10 Hz, Sweep: Auto.
4. “ * ”, means this data is the worst emission level.
5. Measurement Level = Reading Level + Correct Factor.
6. The average measurement was not performed when the peak measured data under the limit of average detection.

Site : Site 1	Time : 2008/06/17 - 23:04
Limit : FCC_15.209(961011)_03M_AV	Margin : 6
Probe : CB3_FCC_1-18G(2007) - VERTICAL	Power :
EUT : WIRELESS G ADSL2+ MODEM ROUTER	Note : TX-2462-N(20M)

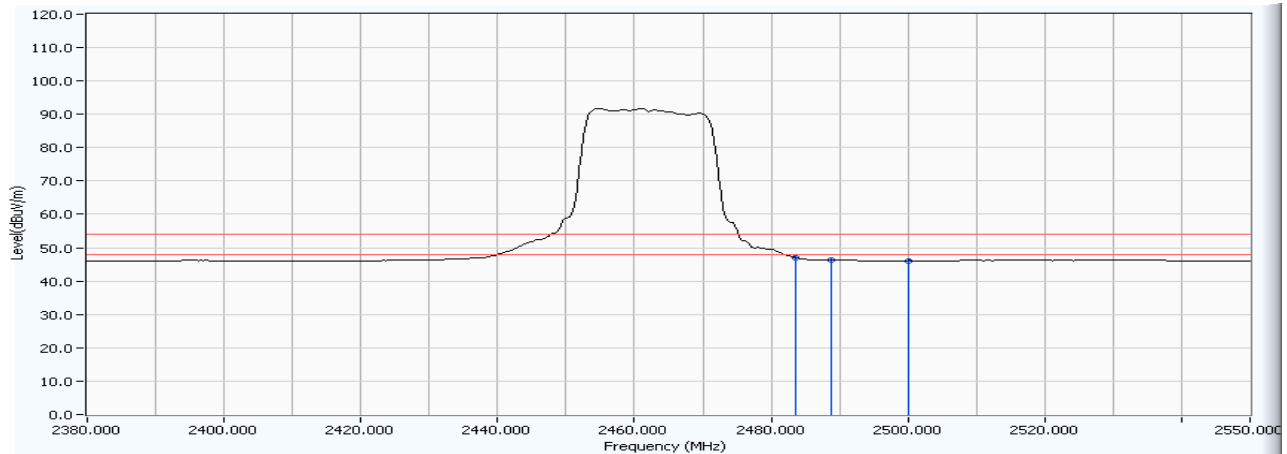

	Frequency (MHz)	Correct Factor (dB)	Reading Level (dBuV)	Measure Level (dBuV/m)	Margin (dB)	Limit (dBuV/m)	Detector Type
1	2483.500	29.064	18.065	47.128	-6.872	54.000	AVERAGE
2	* 2488.677	29.079	17.261	46.339	-7.661	54.000	AVERAGE
3	2500.000	29.114	17.048	46.162	-7.838	54.000	AVERAGE

Note:

1. All readings above 1GHz are performed with peak and/or average measurements as necessary.
2. Peak measurements: RBW = 1MHz, VBW = 3 MHz, Sweep: Auto.
3. Average measurements: RBW = 1MHz, VBW = 10 Hz, Sweep: Auto.
4. “ * ”, means this data is the worst emission level.
5. Measurement Level = Reading Level + Correct Factor.
6. The average measurement was not performed when the peak measured data under the limit of average detection.

Site : Site 1	Time : 2008/06/17 - 23:38
Limit : FCC_15.209(961011)_03M_PK	Margin : 6
Probe : CB3_FCC_1-18G(2007) - HORIZONTAL	Power :
EUT : WIRELESS G ADSL2+ MODEM ROUTER	Note : TX-2422-N(40M)

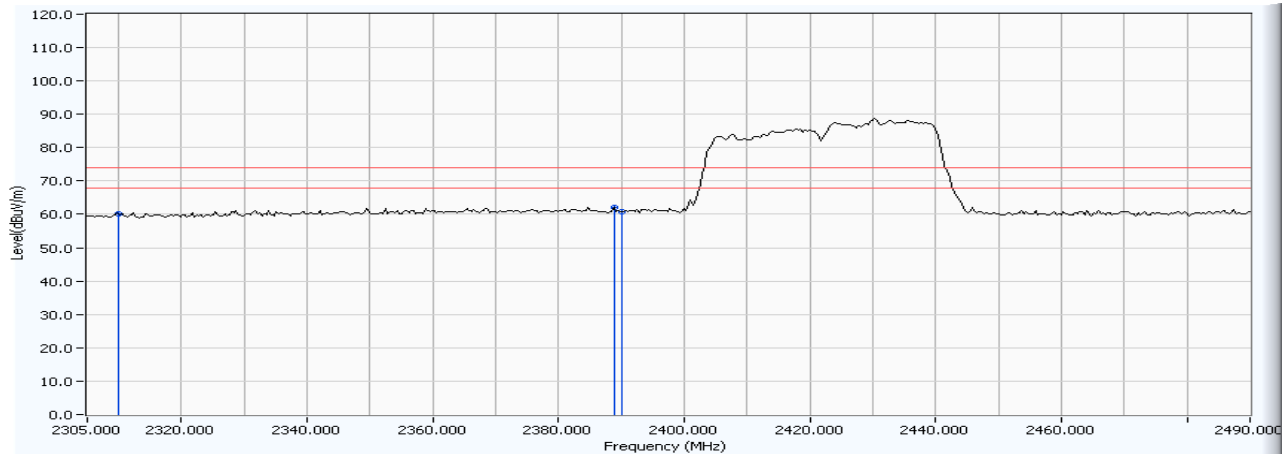

	Frequency (MHz)	Correct Factor (dB)	Reading Level (dBuV)	Measure Level (dBuV/m)	Margin (dB)	Limit (dBuV/m)	Detector Type
1	2310.000	30.412	29.773	60.184	-13.816	74.000	PEAK
2	* 2388.788	30.541	31.609	62.150	-11.850	74.000	PEAK
3	2390.000	30.543	30.282	60.825	-13.175	74.000	PEAK

Note:

1. All readings above 1GHz are performed with peak and/or average measurements as necessary.
2. Peak measurements: RBW = 1MHz, VBW = 3 MHz, Sweep: Auto.
3. Average measurements: RBW = 1MHz, VBW = 10 Hz, Sweep: Auto.
4. “ * ”, means this data is the worst emission level.
5. Measurement Level = Reading Level + Correct Factor.
6. The average measurement was not performed when the peak measured data under the limit of average detection.

Site : Site 1	Time : 2008/06/17 - 23:40
Limit : FCC_15.209(961011)_03M_AV	Margin : 6
Probe : CB3_FCC_1-18G(2007) - HORIZONTAL	Power :
EUT : WIRELESS G ADSL2+ MODEM ROUTER	Note : TX-2422-N(40M)

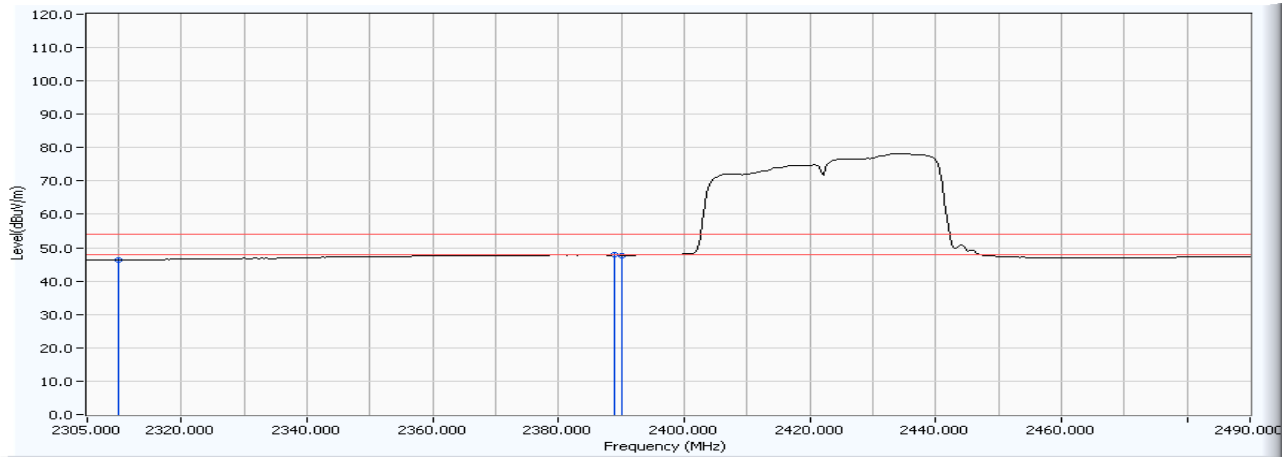

	Frequency (MHz)	Correct Factor (dB)	Reading Level (dBuV)	Measure Level (dBuV/m)	Margin (dB)	Limit (dBuV/m)	Detector Type
1	2310.000	30.412	15.966	46.377	-7.623	54.000	AVERAGE
2	* 2388.788	30.541	17.251	47.792	-6.208	54.000	AVERAGE
3	2390.000	30.543	17.223	47.766	-6.234	54.000	AVERAGE

Note:

1. All readings above 1GHz are performed with peak and/or average measurements as necessary.
2. Peak measurements: RBW = 1MHz, VBW = 3 MHz, Sweep: Auto.
3. Average measurements: RBW = 1MHz, VBW = 10 Hz, Sweep: Auto.
4. “ * ”, means this data is the worst emission level.
5. Measurement Level = Reading Level + Correct Factor.
6. The average measurement was not performed when the peak measured data under the limit of average detection.

Site : Site 1	Time : 2008/06/17 - 23:46
Limit : FCC_15.209(961011)_03M_PK	Margin : 6
Probe : CB3_FCC_1-18G(2007) - VERTICAL	Power :
EUT : WIRELESS G ADSL2+ MODEM ROUTER	Note : TX-2422-N(40M)

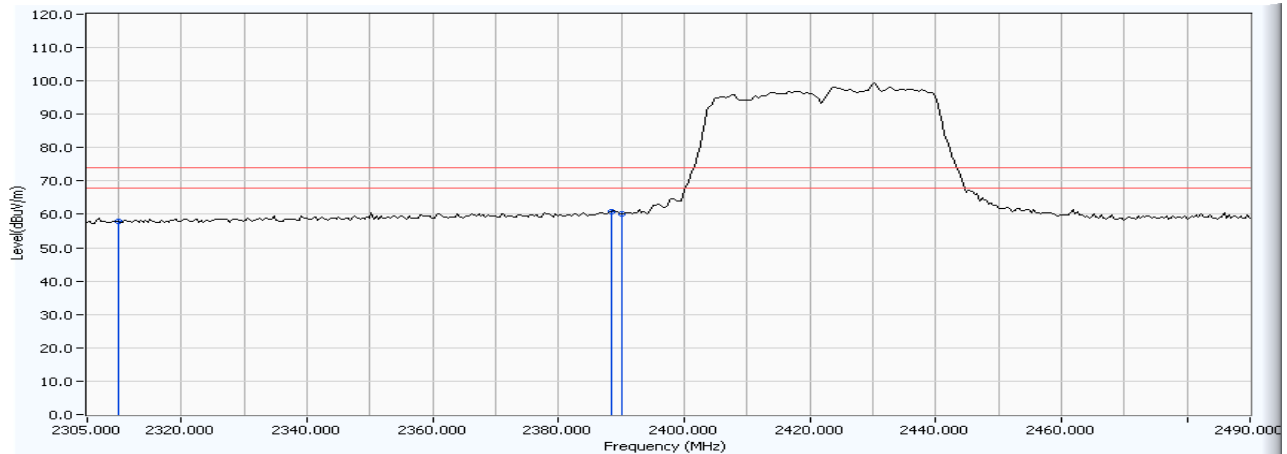

	Frequency (MHz)	Correct Factor (dB)	Reading Level (dBuV)	Measure Level (dBuV/m)	Margin (dB)	Limit (dBuV/m)	Detector Type
1	2310.000	28.433	29.405	57.838	-16.162	74.000	PEAK
2	* 2388.417	28.717	32.105	60.822	-13.178	74.000	PEAK
3	2390.000	28.724	31.580	60.304	-13.696	74.000	PEAK

Note:

1. All readings above 1GHz are performed with peak and/or average measurements as necessary.
2. Peak measurements: RBW = 1MHz, VBW = 3 MHz, Sweep: Auto.
3. Average measurements: RBW = 1MHz, VBW = 10 Hz, Sweep: Auto.
4. “ * ”, means this data is the worst emission level.
5. Measurement Level = Reading Level + Correct Factor.
6. The average measurement was not performed when the peak measured data under the limit of average detection.

Site : Site 1	Time : 2008/06/17 - 23:47
Limit : FCC_15.209(961011)_03M_AV	Margin : 6
Probe : CB3_FCC_1-18G(2007) - VERTICAL	Power :
EUT : WIRELESS G ADSL2+ MODEM ROUTER	Note : TX-2422-N(40M)

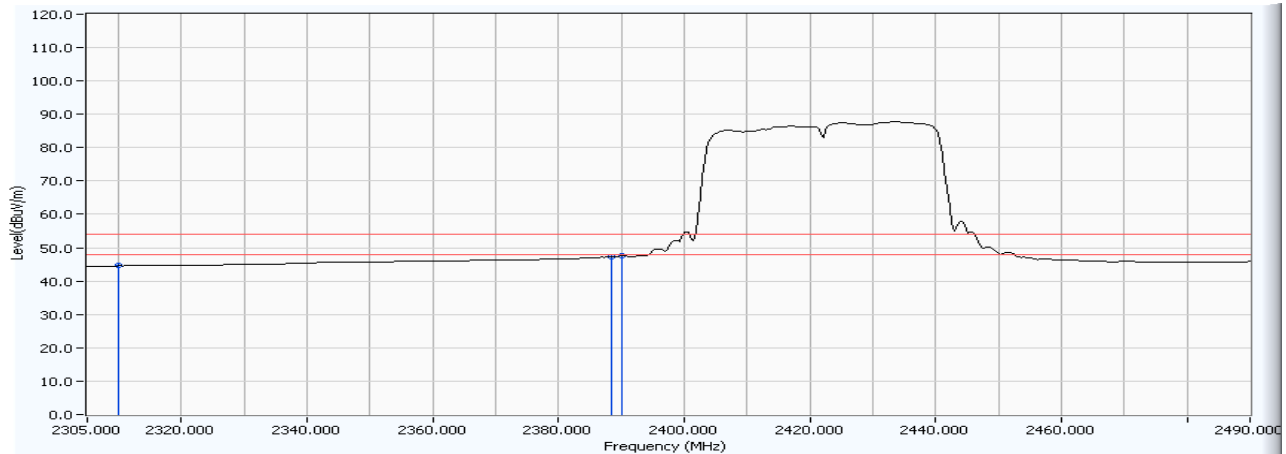

	Frequency (MHz)	Correct Factor (dB)	Reading Level (dBuV)	Measure Level (dBuV/m)	Margin (dB)	Limit (dBuV/m)	Detector Type
1	2310.000	28.433	16.134	44.567	-9.433	54.000	AVERAGE
2	* 2388.417	28.717	18.469	47.186	-6.814	54.000	AVERAGE
3	2390.000	28.724	18.750	47.474	-6.526	54.000	AVERAGE

Note:

1. All readings above 1GHz are performed with peak and/or average measurements as necessary.
2. Peak measurements: RBW = 1MHz, VBW = 3 MHz, Sweep: Auto.
3. Average measurements: RBW = 1MHz, VBW = 10 Hz, Sweep: Auto.
4. “ * ”, means this data is the worst emission level.
5. Measurement Level = Reading Level + Correct Factor.
6. The average measurement was not performed when the peak measured data under the limit of average detection.

Site : Site 1	Time : 2008/06/17 - 23:55
Limit : FCC_15.209(961011)_03M_PK	Margin : 6
Probe : CB3_FCC_1-18G(2007) - HORIZONTAL	Power :
EUT : WIRELESS G ADSL2+ MODEM ROUTER	Note : TX-2452-N(40M)

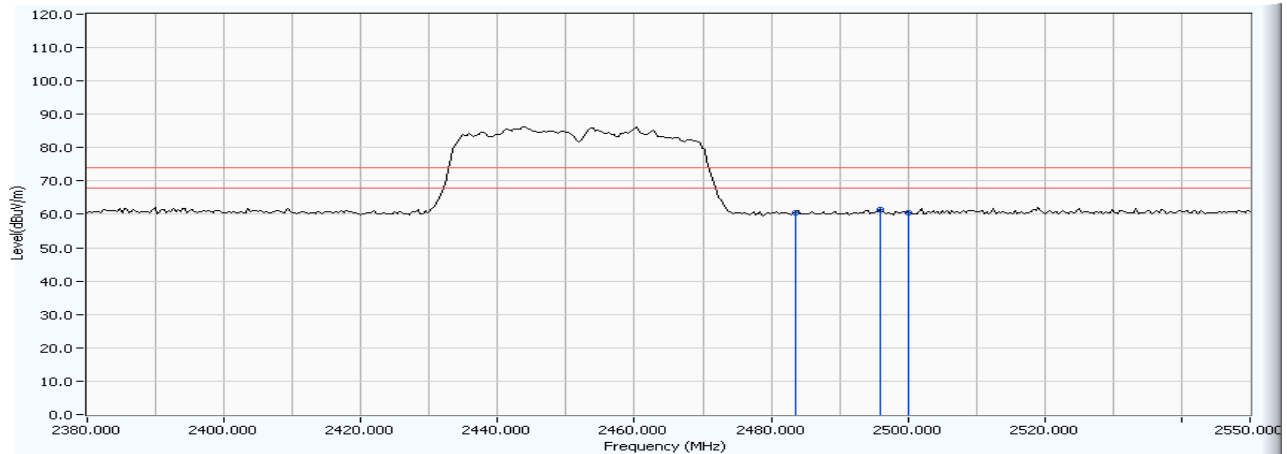

	Frequency (MHz)	Correct Factor (dB)	Reading Level (dBuV)	Measure Level (dBuV/m)	Margin (dB)	Limit (dBuV/m)	Detector Type
1	2483.500	30.696	29.926	60.621	-13.379	74.000	PEAK
2	* 2495.832	30.710	30.791	61.501	-12.499	74.000	PEAK
3	2500.000	30.722	29.906	60.628	-13.372	74.000	PEAK

Note:

1. All readings above 1GHz are performed with peak and/or average measurements as necessary.
2. Peak measurements: RBW = 1MHz, VBW = 3 MHz, Sweep: Auto.
3. Average measurements: RBW = 1MHz, VBW = 10 Hz, Sweep: Auto.
4. “ * ”, means this data is the worst emission level.
5. Measurement Level = Reading Level + Correct Factor.
6. The average measurement was not performed when the peak measured data under the limit of average detection.

Site : Site 1	Time : 2008/06/17 - 23:56
Limit : FCC_15.209(961011)_03M_AV	Margin : 6
Probe : CB3_FCC_1-18G(2007) - HORIZONTAL	Power :
EUT : WIRELESS G ADSL2+ MODEM ROUTER	Note : TX-2452-N(40M)

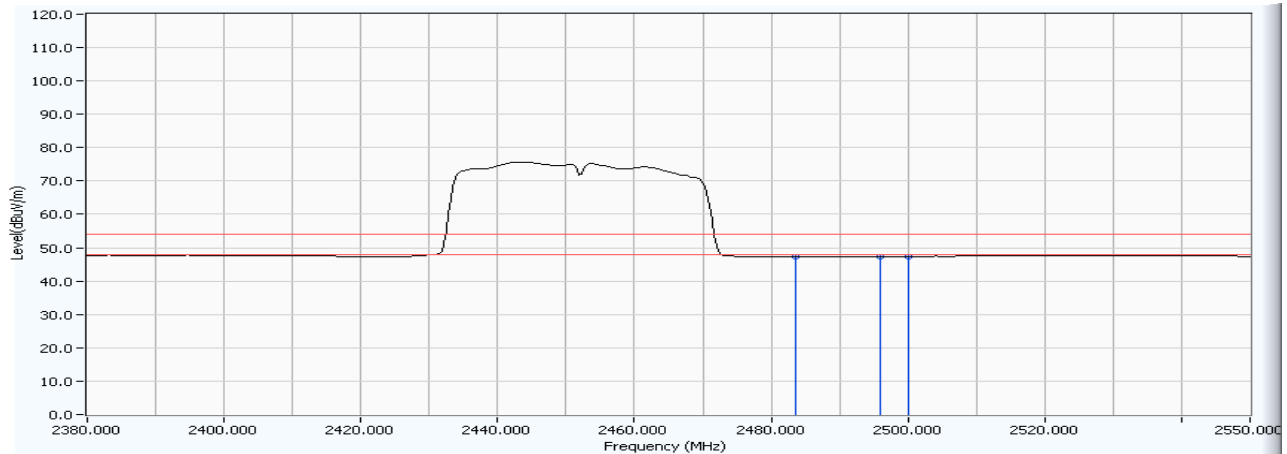

	Frequency (MHz)	Correct Factor (dB)	Reading Level (dBuV)	Measure Level (dBuV/m)	Margin (dB)	Limit (dBuV/m)	Detector Type
1	2483.500	30.696	16.498	47.193	-6.807	54.000	AVERAGE
2	* 2495.832	30.710	16.620	47.330	-6.670	54.000	AVERAGE
3	2500.000	30.722	16.679	47.401	-6.599	54.000	AVERAGE

Note:

1. All readings above 1GHz are performed with peak and/or average measurements as necessary.
2. Peak measurements: RBW = 1MHz, VBW = 3 MHz, Sweep: Auto.
3. Average measurements: RBW = 1MHz, VBW = 10 Hz, Sweep: Auto.
4. “ * ”, means this data is the worst emission level.
5. Measurement Level = Reading Level + Correct Factor.
6. The average measurement was not performed when the peak measured data under the limit of average detection.

Site : Site 1	Time : 2008/06/18 - 00:01
Limit : FCC_15.209(961011)_03M_PK	Margin : 6
Probe : CB3_FCC_1-18G(2007) - VERTICAL	Power :
EUT : WIRELESS G ADSL2+ MODEM ROUTER	Note : TX-2452-N(40M)

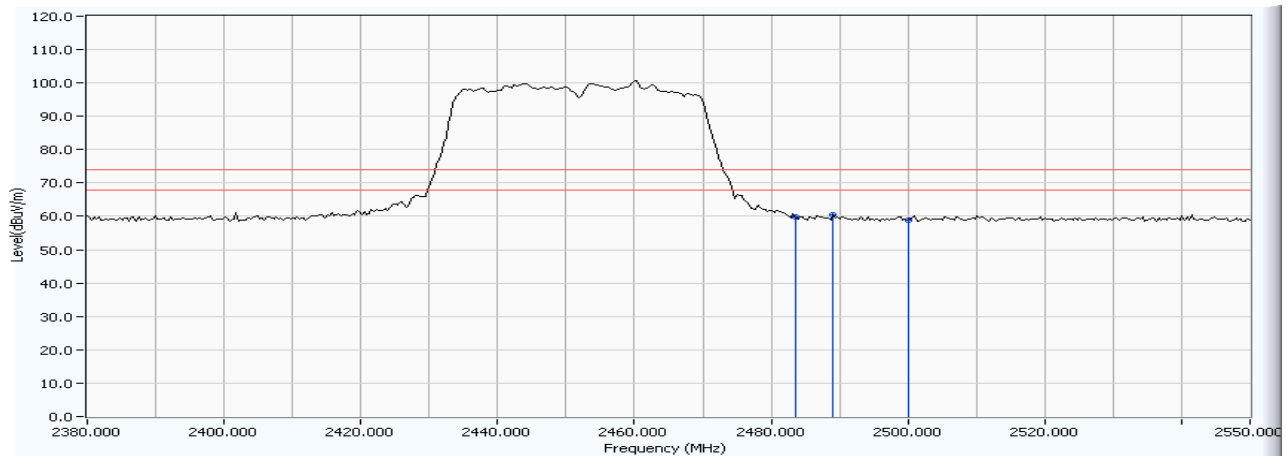

	Frequency (MHz)	Correct Factor (dB)	Reading Level (dBuV)	Measure Level (dBuV/m)	Margin (dB)	Limit (dBuV/m)	Detector Type
1	2483.500	29.064	30.701	59.764	-14.236	74.000	PEAK
2	* 2489.018	29.080	31.315	60.394	-13.606	74.000	PEAK
3	2500.000	29.114	29.859	58.973	-15.027	74.000	PEAK

Note:

1. All readings above 1GHz are performed with peak and/or average measurements as necessary.
2. Peak measurements: RBW = 1MHz, VBW = 3 MHz, Sweep: Auto.
3. Average measurements: RBW = 1MHz, VBW = 10 Hz, Sweep: Auto.
4. “ * ”, means this data is the worst emission level.
5. Measurement Level = Reading Level + Correct Factor.
6. The average measurement was not performed when the peak measured data under the limit of average detection.

Site : Site 1	Time : 2008/06/18 - 00:03
Limit : FCC_15.209(961011)_03M_AV	Margin : 6
Probe : CB3_FCC_1-18G(2007) - VERTICAL	Power :
EUT : WIRELESS G ADSL2+ MODEM ROUTER	Note : TX-2452-N(40M)

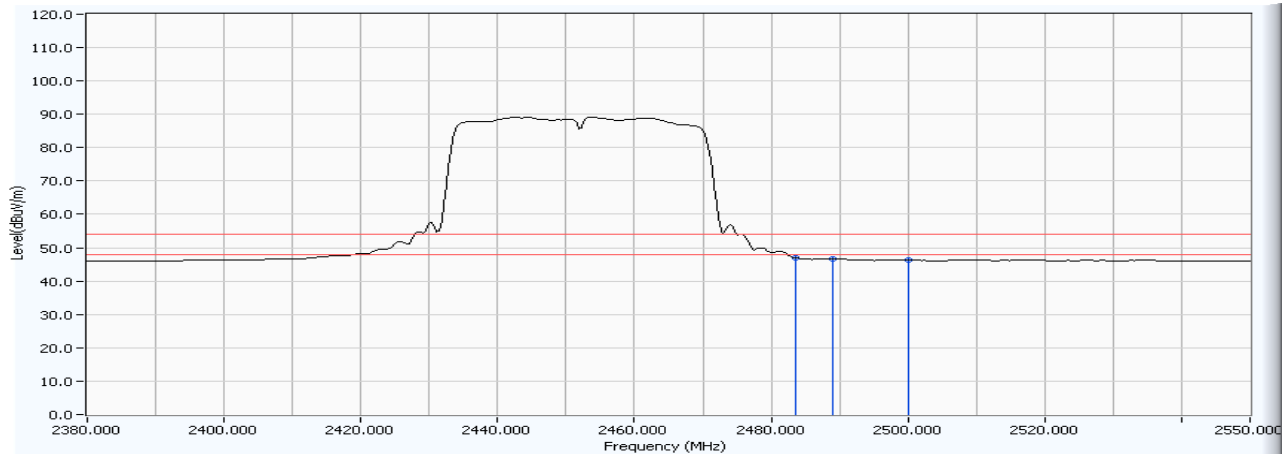

	Frequency (MHz)	Correct Factor (dB)	Reading Level (dBuV)	Measure Level (dBuV/m)	Margin (dB)	Limit (dBuV/m)	Detector Type
1	2483.500	29.064	17.836	46.899	-7.101	54.000	AVERAGE
2	* 2489.018	29.080	17.467	46.546	-7.454	54.000	AVERAGE
3	2500.000	29.114	17.153	46.267	-7.733	54.000	AVERAGE

Note:

1. All readings above 1GHz are performed with peak and/or average measurements as necessary.
2. Peak measurements: RBW = 1MHz, VBW = 3 MHz, Sweep: Auto.
3. Average measurements: RBW = 1MHz, VBW = 10 Hz, Sweep: Auto.
4. “ * ”, means this data is the worst emission level.
5. Measurement Level = Reading Level + Correct Factor.
6. The average measurement was not performed when the peak measured data under the limit of average detection.

7. Occupied Bandwidth

7.1. Test Equipment

The following test equipments are used during the radiated emission tests:

Item	Equipment	Manufacturer	Model No. / Serial No.	Last Cal.
1	Spectrum Analyzer	R & S	FSP / 100561	Mar., 2008
2	No.1 OATS			Sep., 2007

Note: 1. All equipments that need to calibrate are with calibration period of 1 year.

7.2. Test Setup

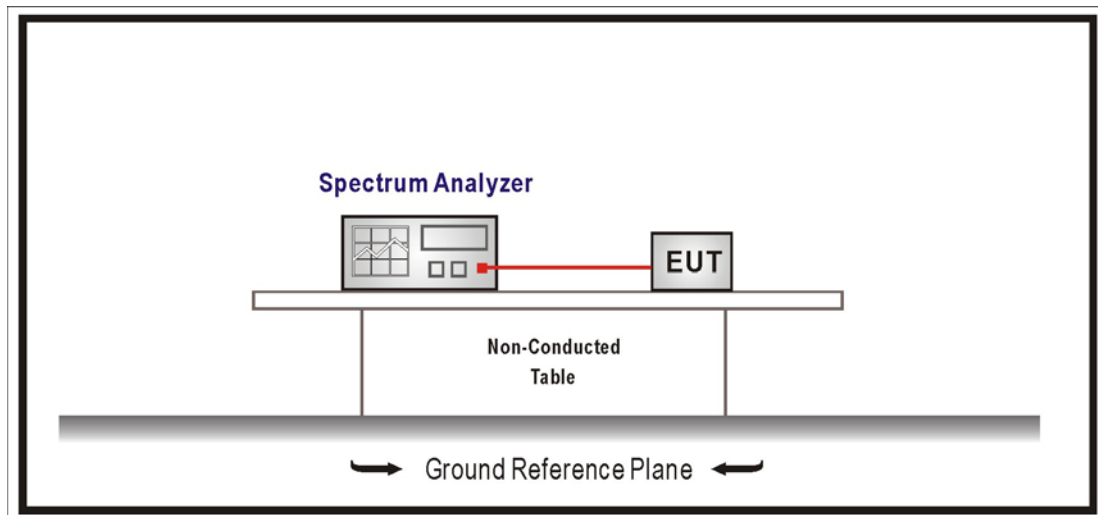

7.3. Limits

Systems using digital modulation techniques may operate in the 902–928 MHz, 2400–2483.5 MHz, and 5725–5850MHz bands.

When an occupied bandwidth value is not specified in the applicable RSS, the transmitted signal bandwidth to be reported is to be its 99% emission bandwidth, as calculated or measured.

7.4. Uncertainty

The measurement uncertainty is defined as $\pm 50\text{kHz}$

7.5. Test Result

Product	WIRELESS G ADSL2+ MODEM ROUTER		
Test Item	Occupied Bandwidth		
Test Mode	Transmit		
Date of Test	2008/07/01	Test Site	No.1 OATS

802.11 b				
Channel No.	Frequency (MHz)	Measurement Level (kHz)	Required Limit (kHz)	Result
1	2412.00	12278.5	≥ 500	Pass
6	2437.00	12310.2	≥ 500	Pass
11	2462.00	12244.1	≥ 500	Pass

Channel 1

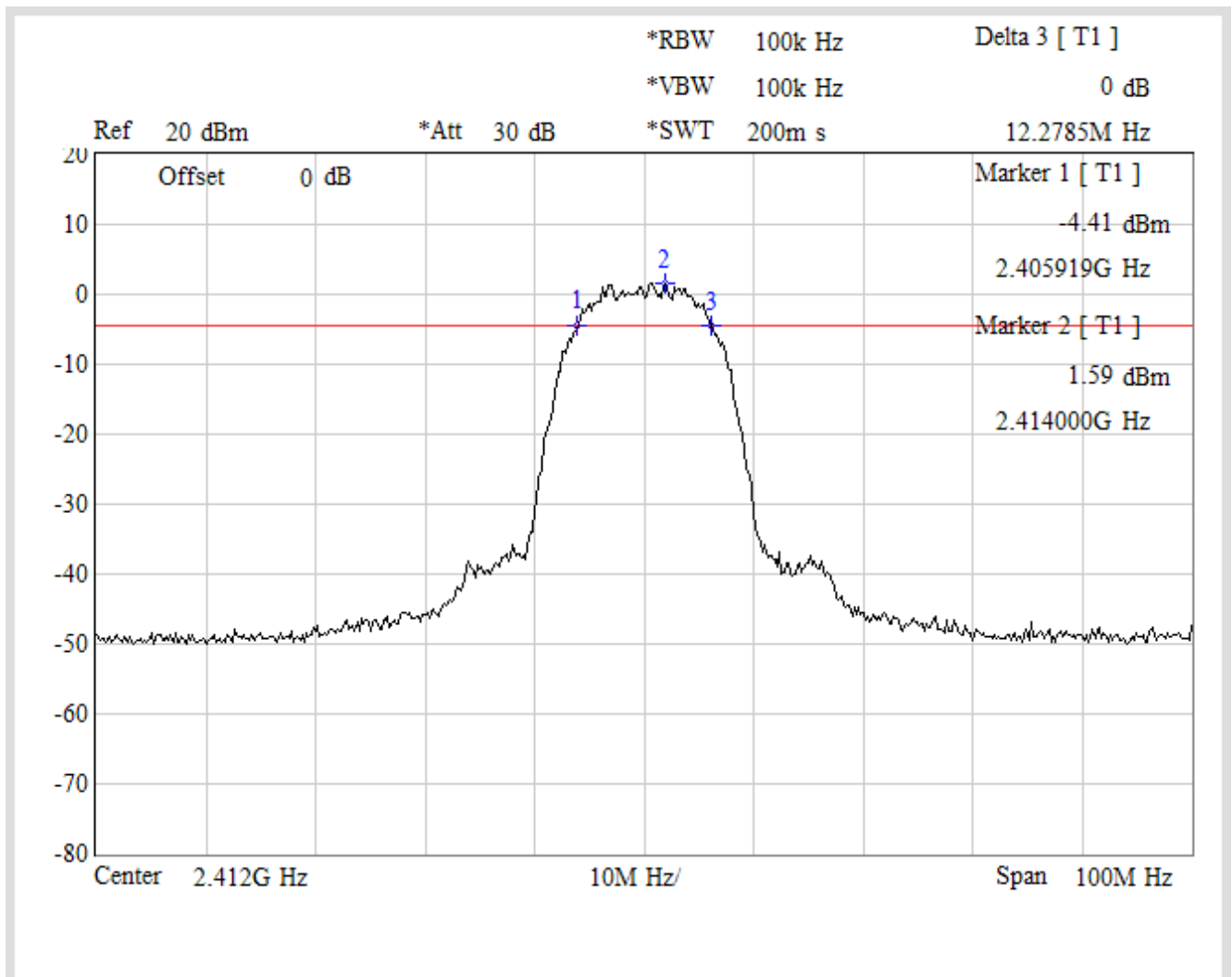

Channel 6

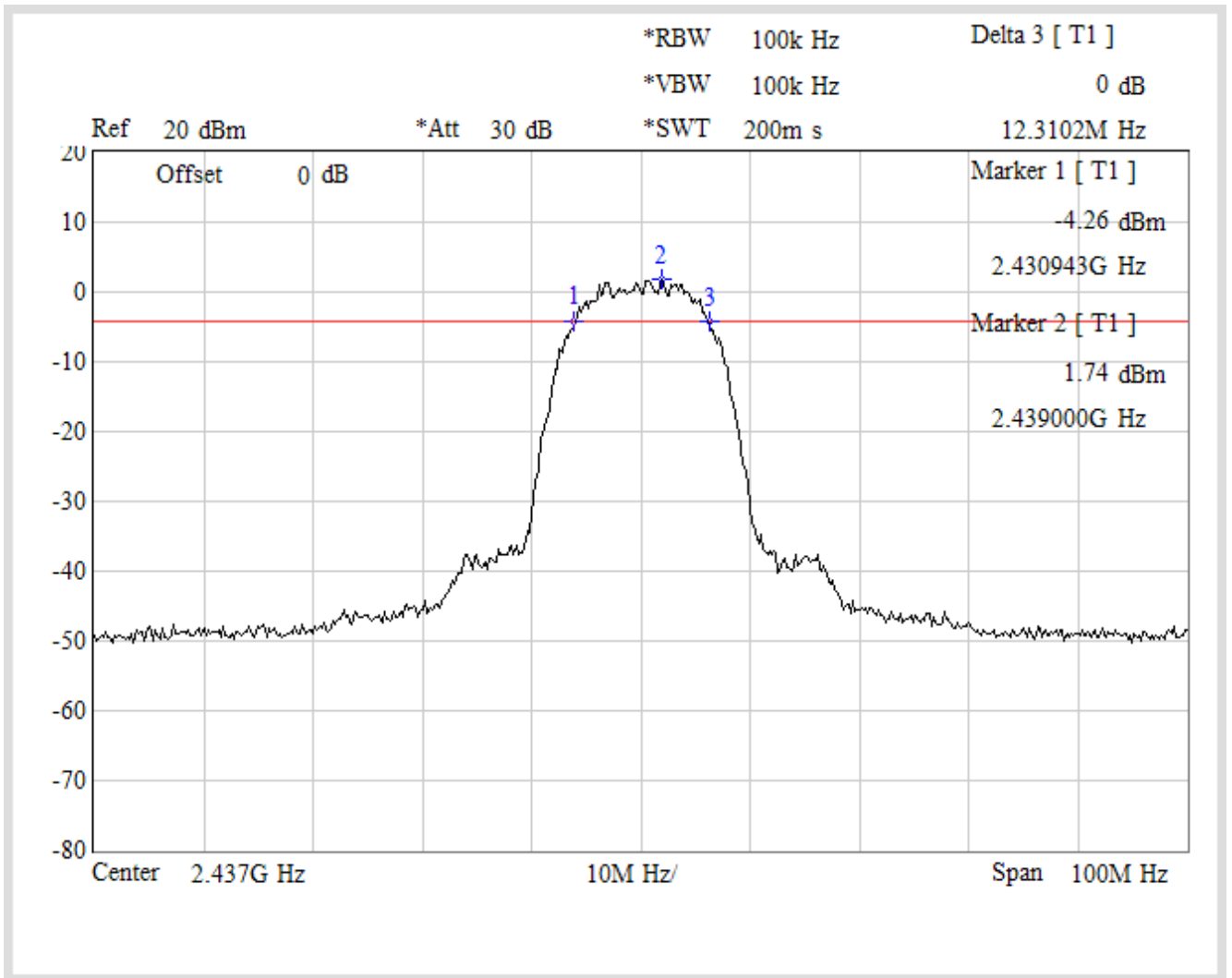

Channel 11

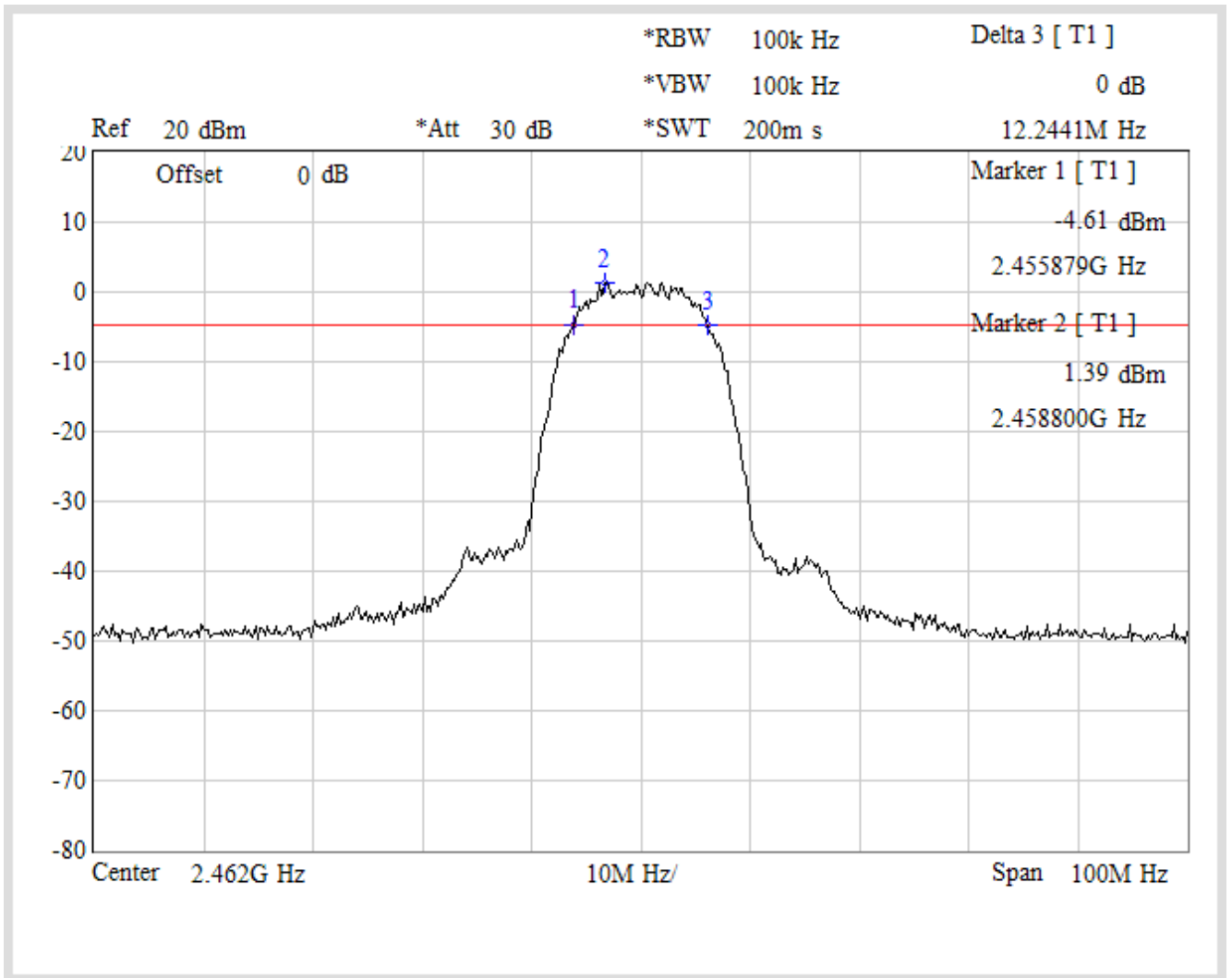

Product	WIRELESS G ADSL2+ MODEM ROUTER		
Test Item	Occupied Bandwidth		
Test Mode	Transmit		
Date of Test	2008/07/01	Test Site	No.1 OATS

IEEE 802.11g				
Channel No.	Frequency (MHz)	Measurement Level (kHz)	Required Limit (kHz)	Result
1	2412.00	16733.0	≥ 500	Pass
6	2437.00	16734.8	≥ 500	Pass
11	2462.00	16717.1	≥ 500	Pass

Channel 1

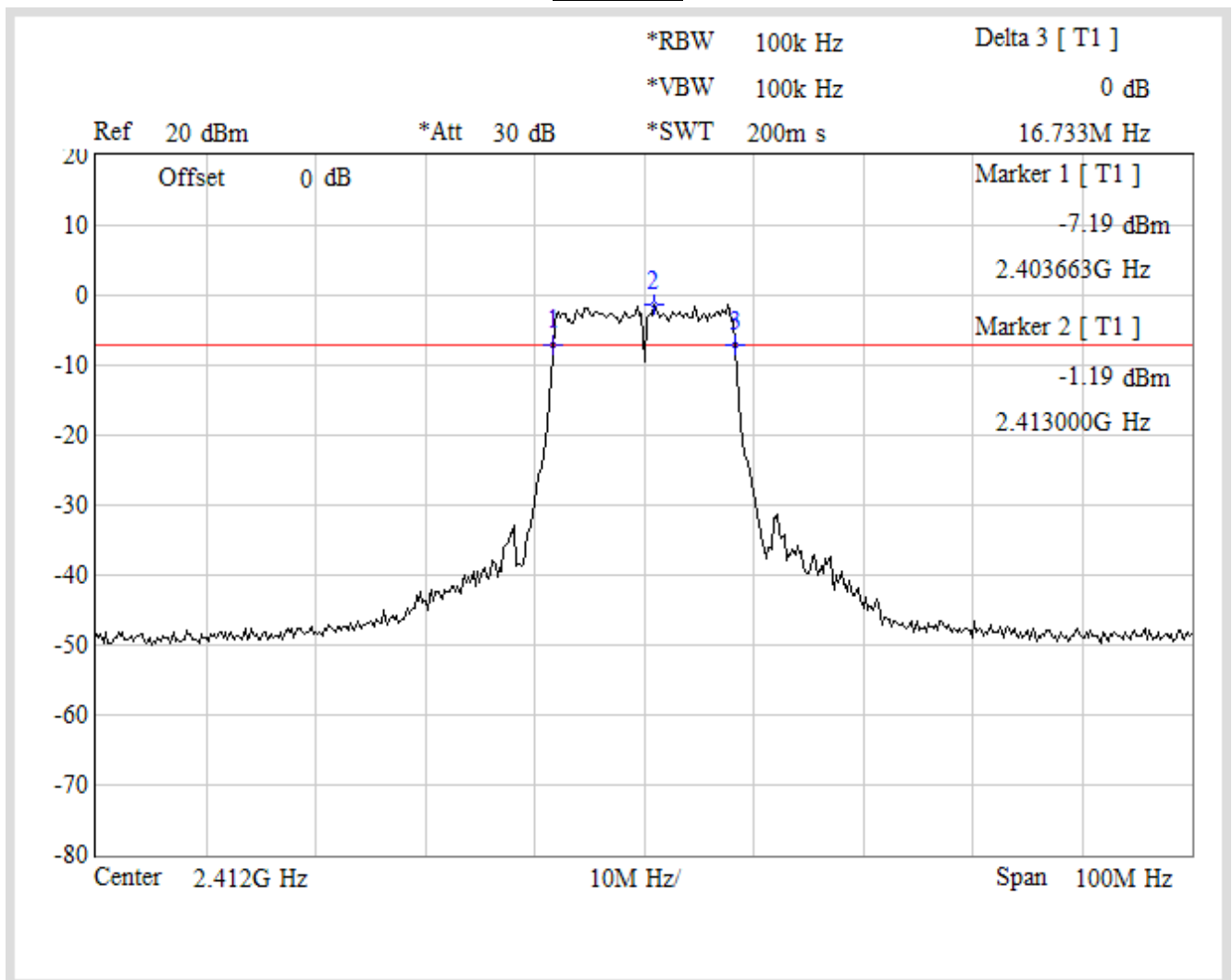

Channel 6

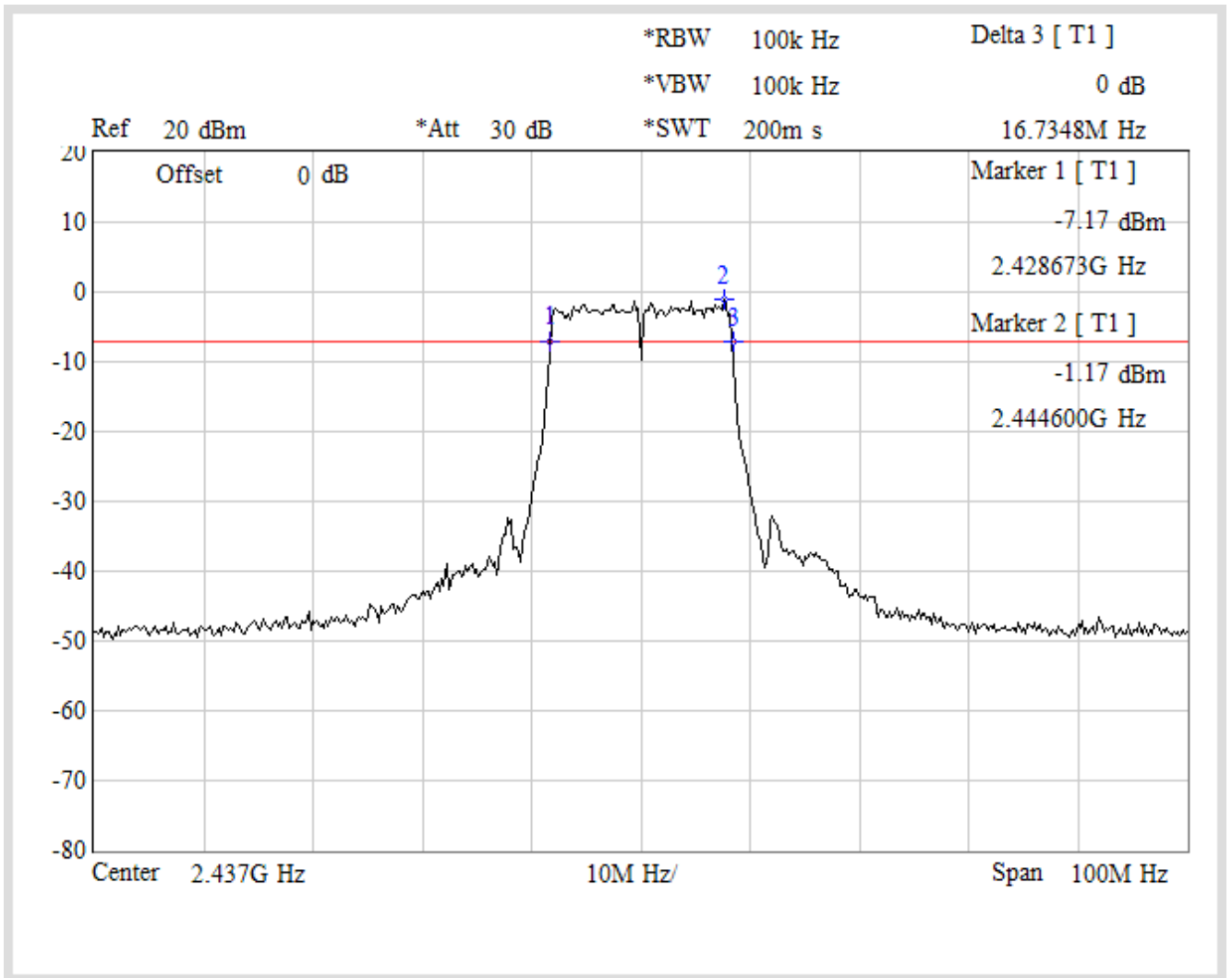

Channel 11

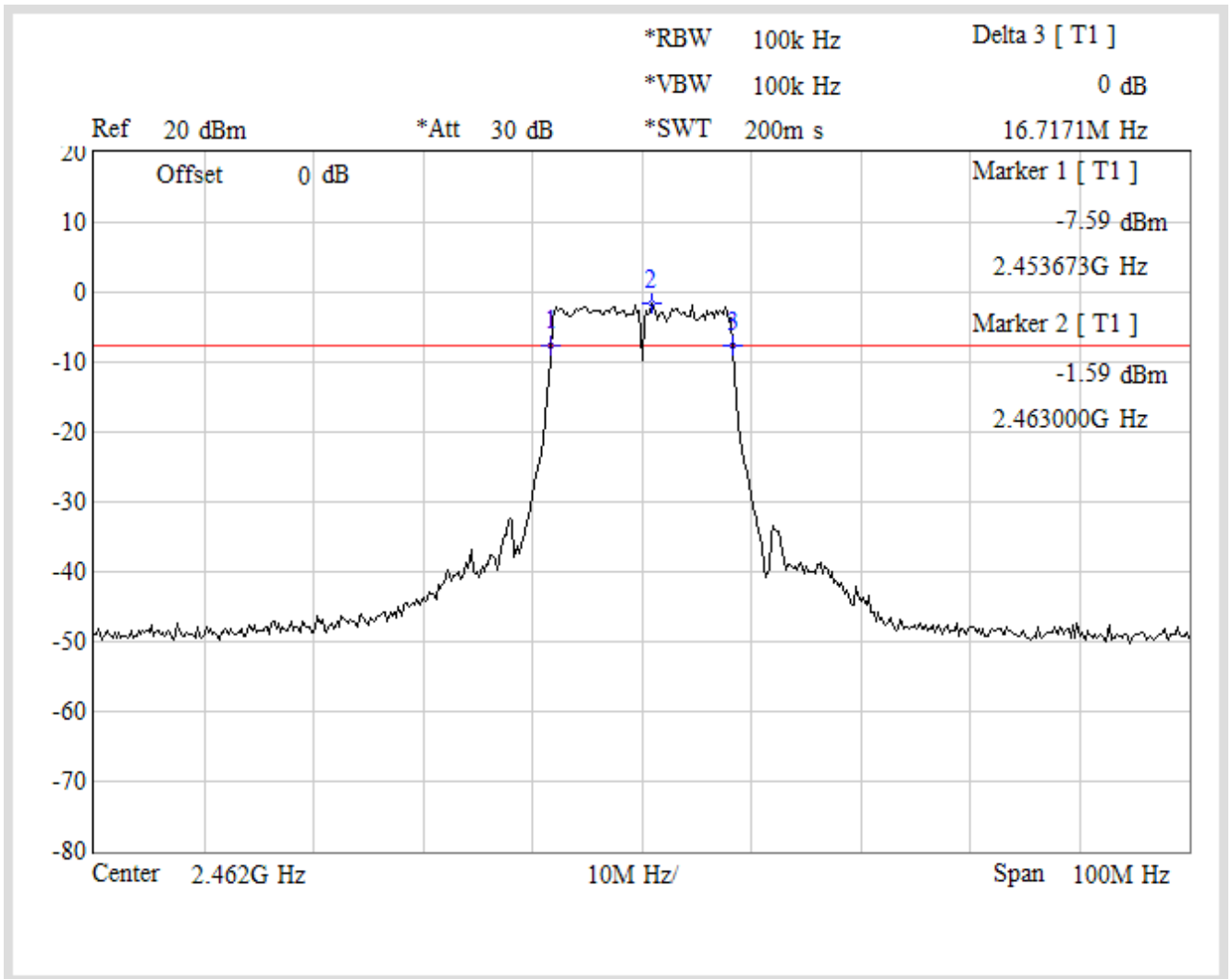

Product	WIRELESS G ADSL2+ MODEM ROUTER		
Test Item	Occupied Bandwidth		
Test Mode	Transmit		
Date of Test	2008/07/01	Test Site	No.1 OATS

IEEE 802.11n (ANT A (20MHz))				
Channel No.	Frequency (MHz)	Measurement Level (kHz)	Required Limit (kHz)	Result
1	2412.00	17837.5	≥ 500	Pass
6	2437.00	17874.1	≥ 500	Pass
11	2462.00	17795.1	≥ 500	Pass

Channel 1

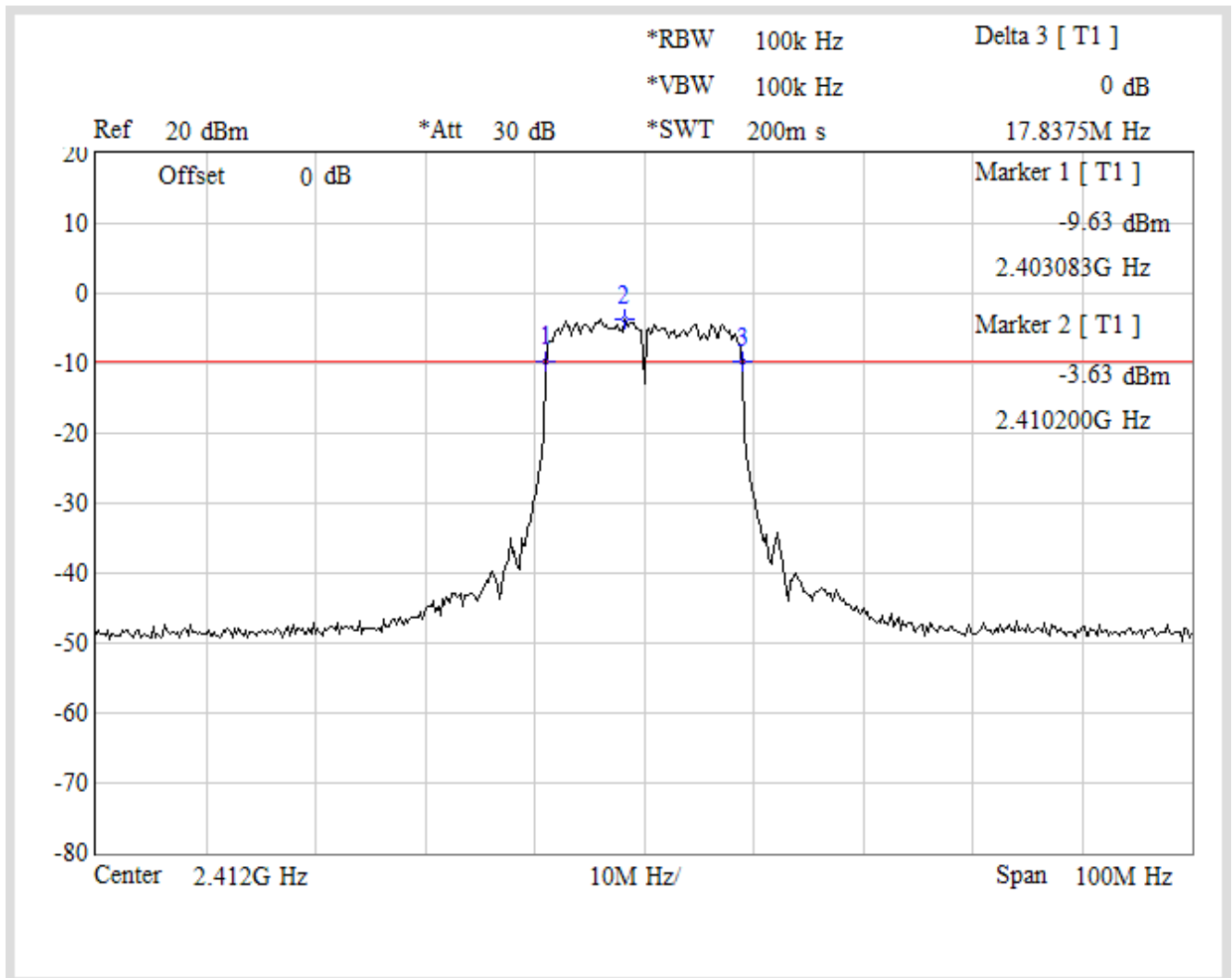

Channel 6

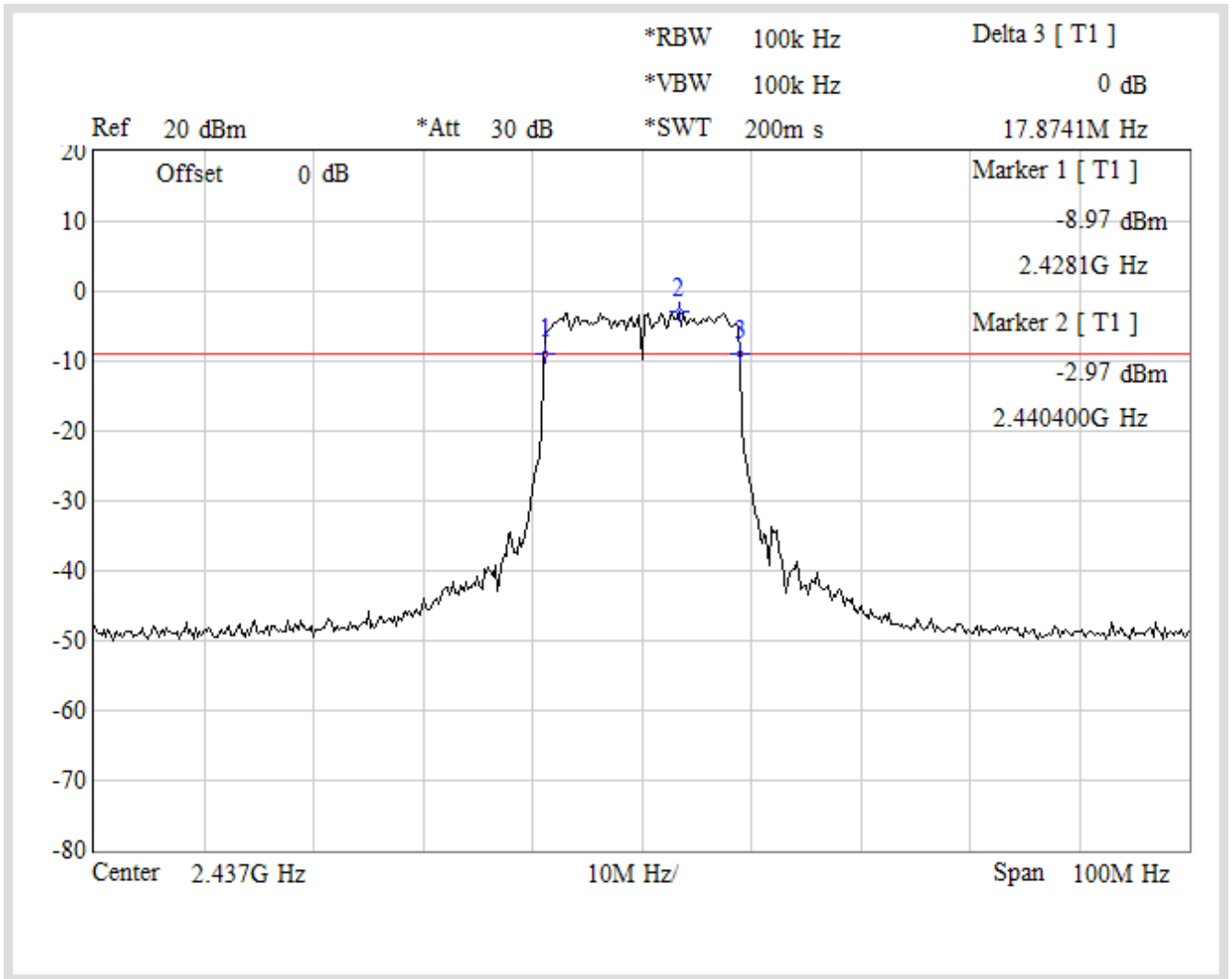

Channel 11

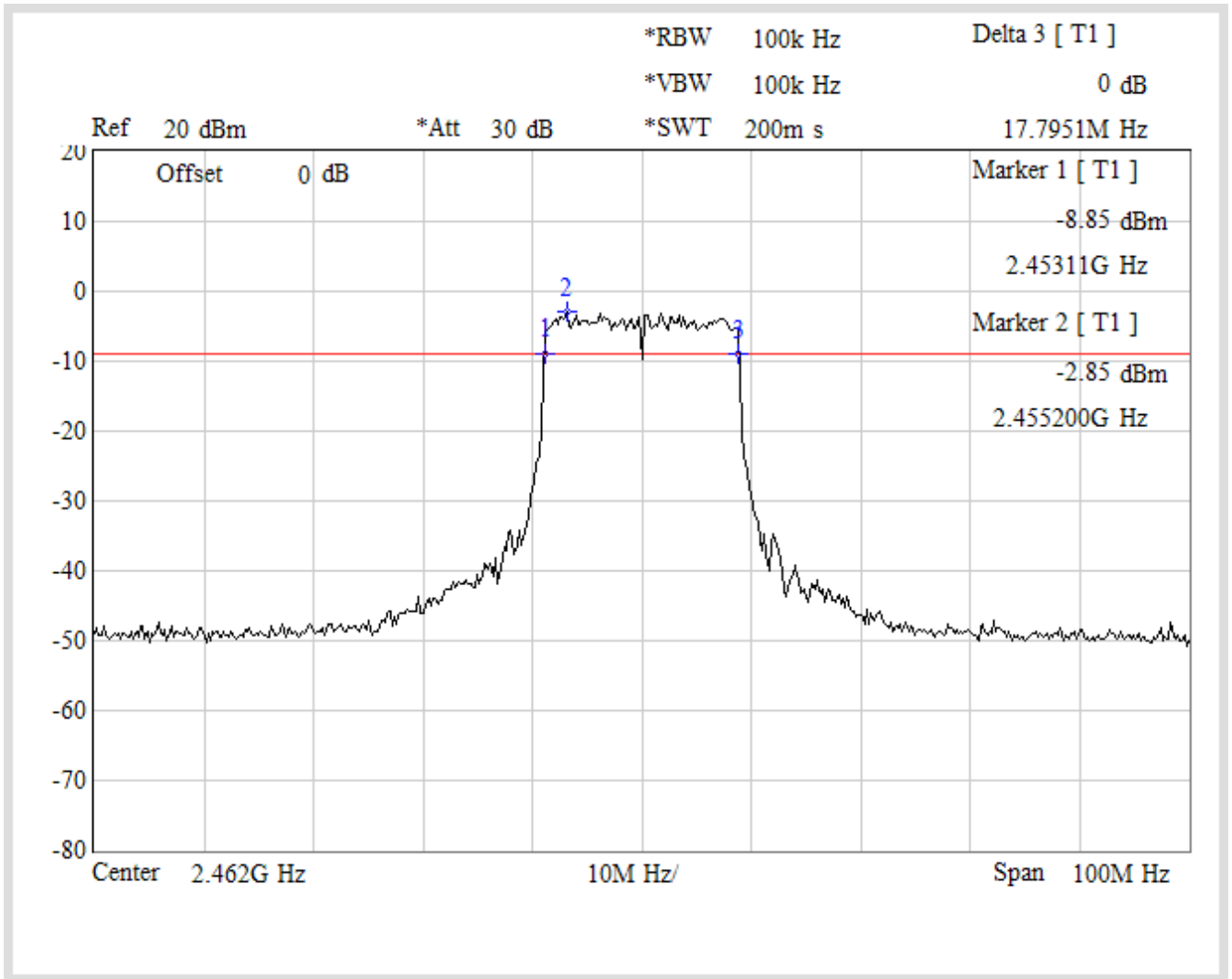

Product	WIRELESS G ADSL2+ MODEM ROUTER		
Test Item	Occupied Bandwidth		
Test Mode	Transmit		
Date of Test	2008/07/01	Test Site	No.1 OATS

IEEE 802.11n (ANT B (20MHz))				
Channel No.	Frequency (MHz)	Measurement Level (kHz)	Required Limit (kHz)	Result
1	2412.00	17894.2	≥ 500	Pass
6	2437.00	17893.4	≥ 500	Pass
11	2462.00	17835.1	≥ 500	Pass

Channel 1

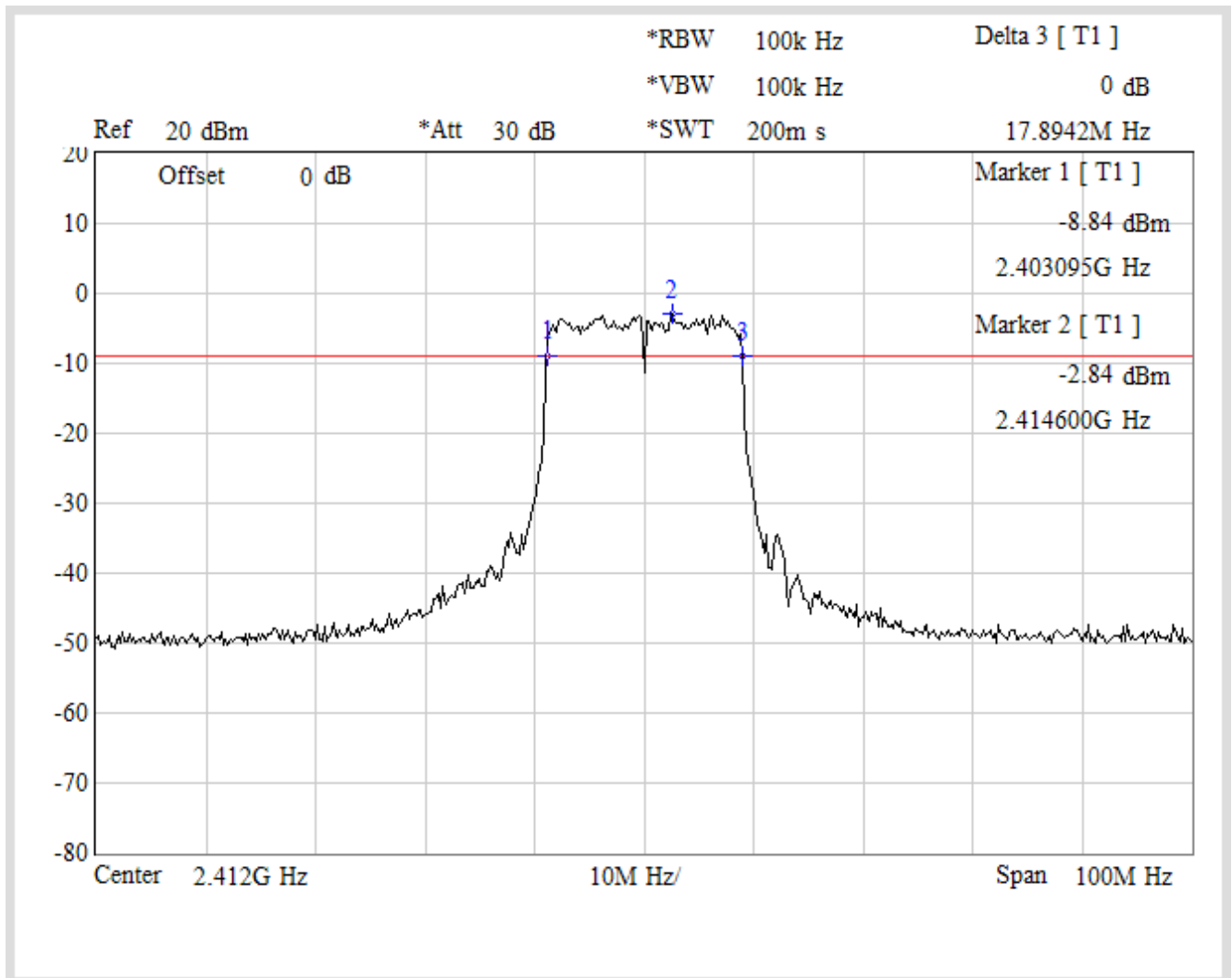

Channel 6

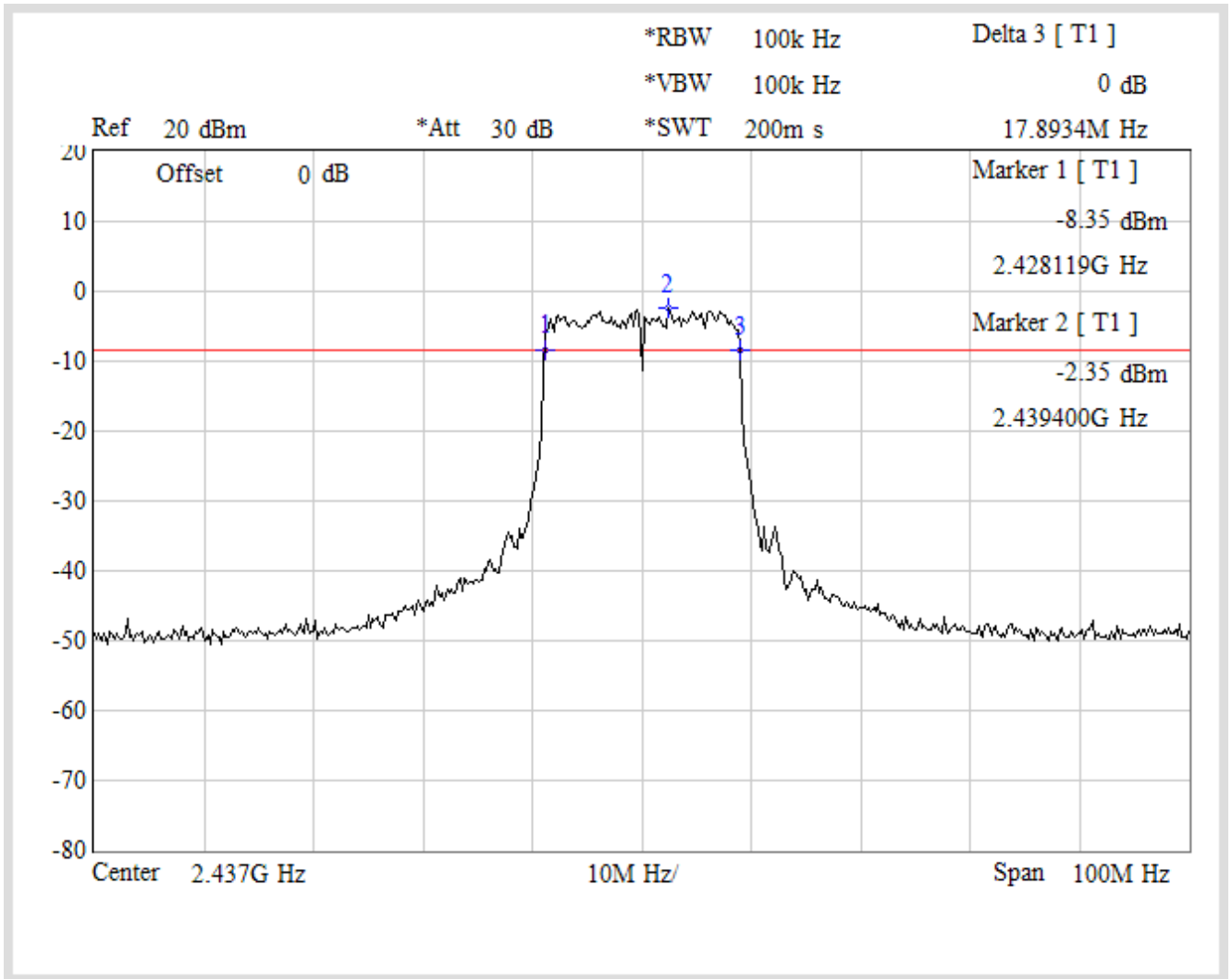

Channel 11

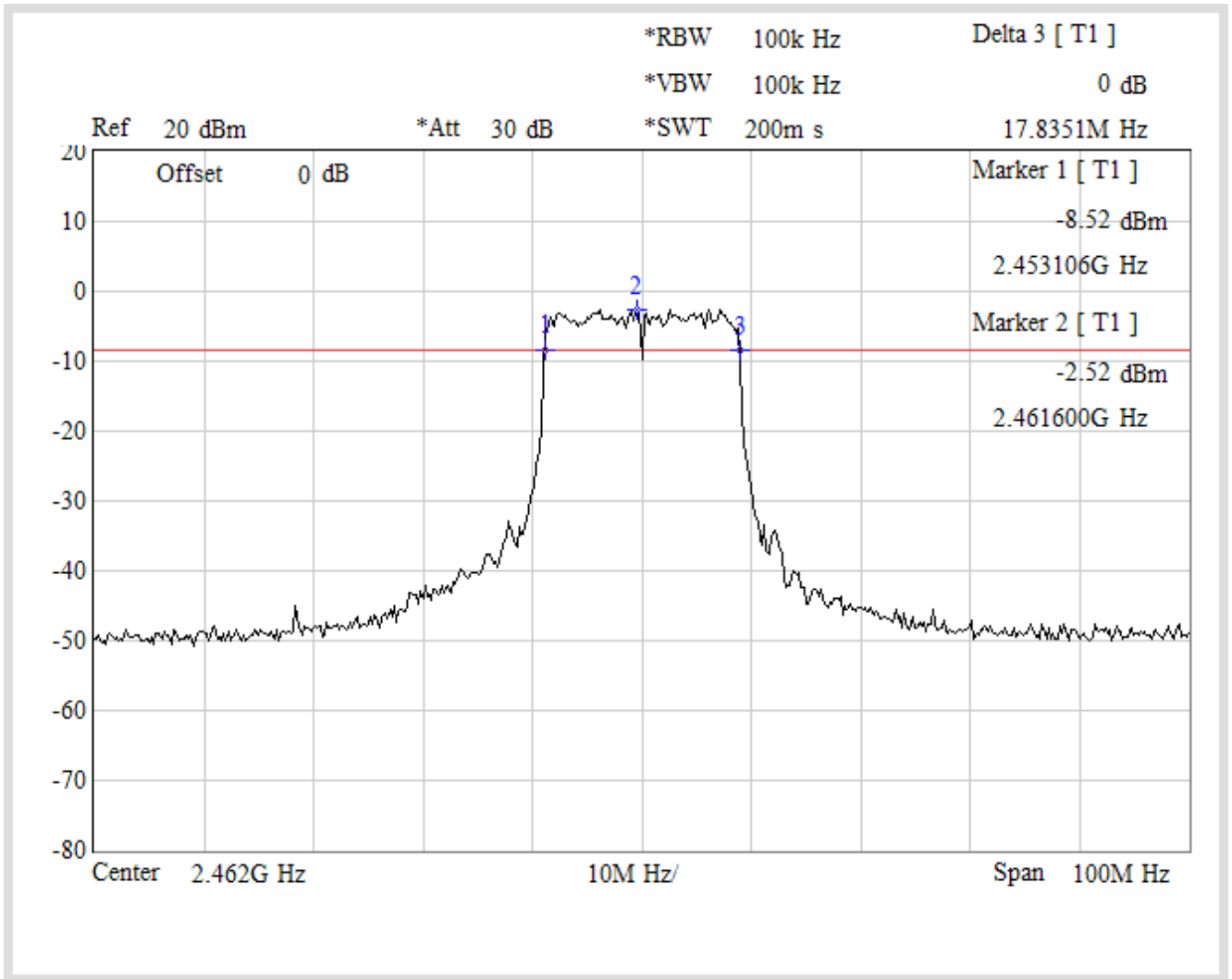

Product	WIRELESS G ADSL2+ MODEM ROUTER		
Test Item	Occupied Bandwidth		
Test Mode	Transmit		
Date of Test	2008/07/01	Test Site	No.1 OATS

IEEE 802.11n (ANT A (40MHz))				
Channel No.	Frequency (MHz)	Measurement Level (kHz)	Required Limit (kHz)	Result
3	2422	36569.9	≥ 500	Pass
6	2437	36534.2	≥ 500	Pass
9	2452	36527.1	≥ 500	Pass

Channel 3

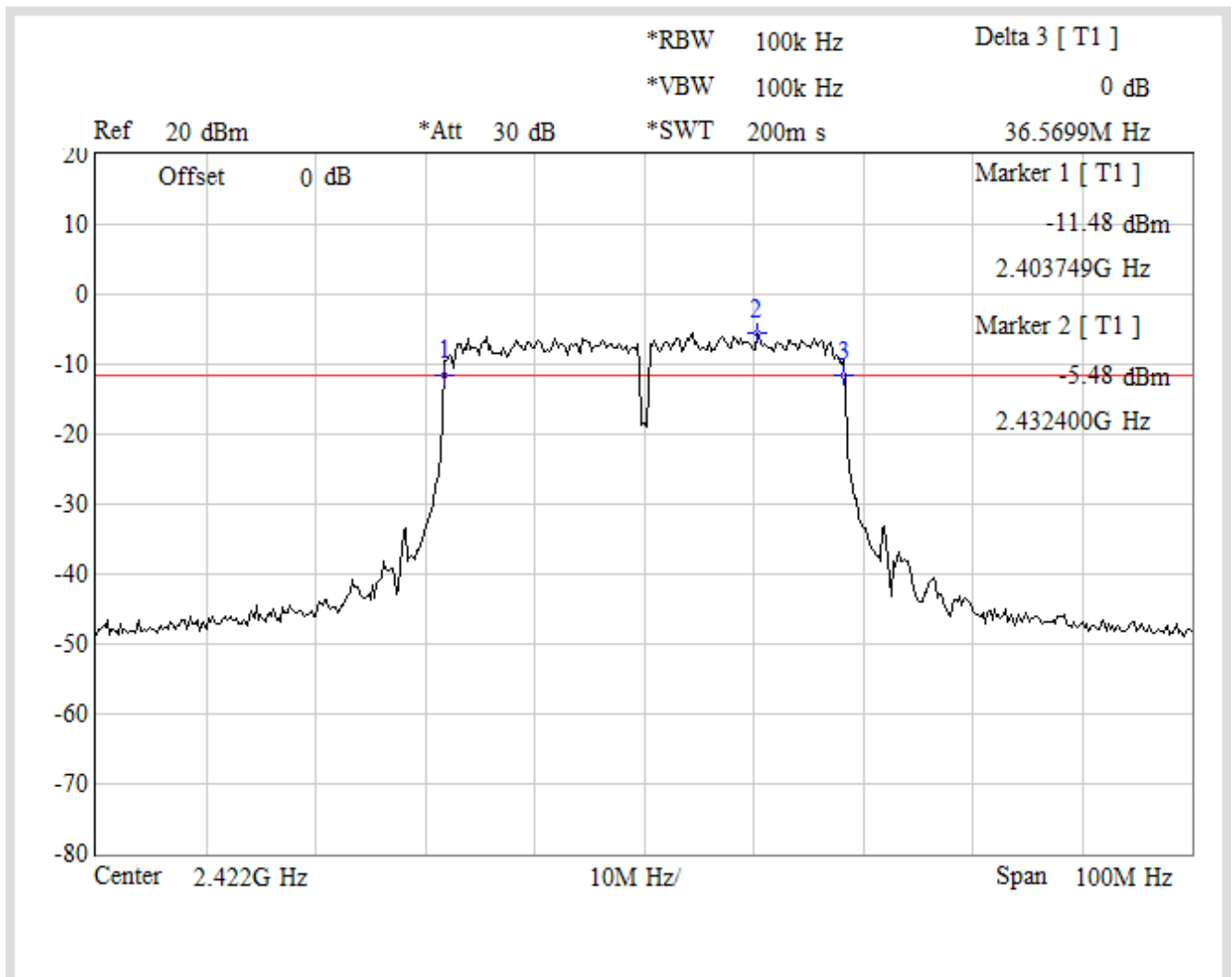

Channel 6

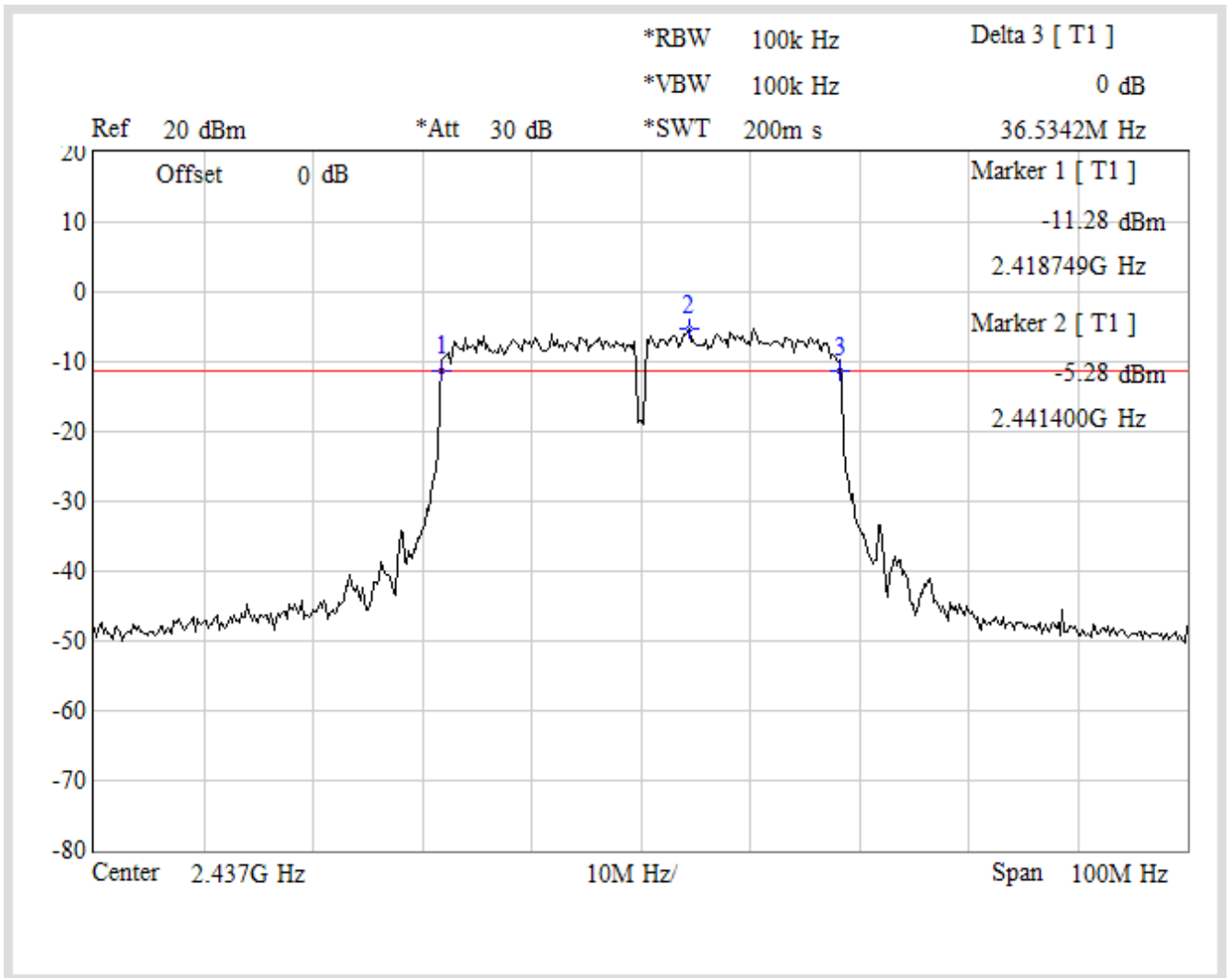

Channel 9

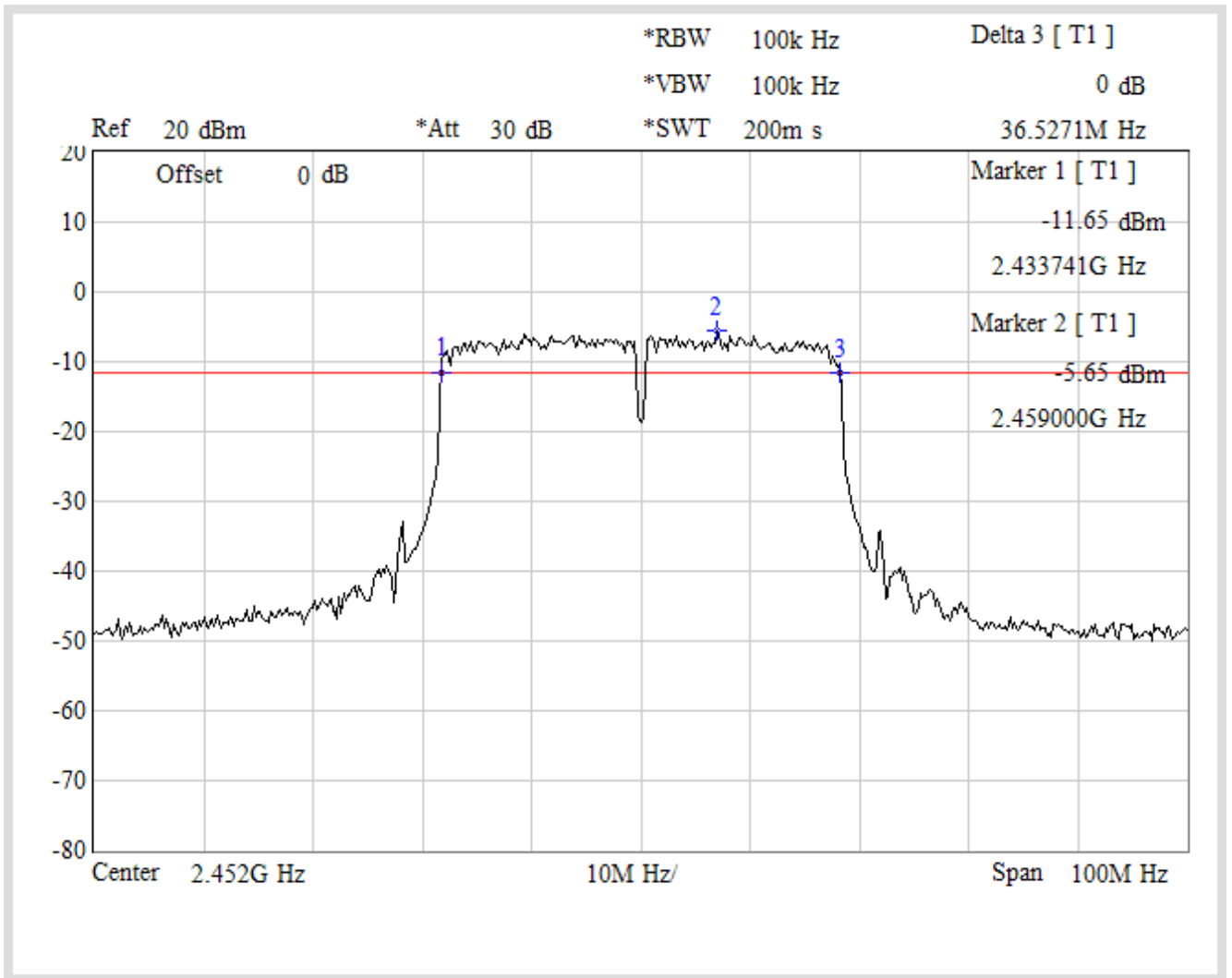

Product	WIRELESS G ADSL2+ MODEM ROUTER		
Test Item	Occupied Bandwidth		
Test Mode	Transmit		
Date of Test	2008/07/01	Test Site	No.1 OATS

IEEE 802.11n (ANT B (40MHz))				
Channel No.	Frequency (MHz)	Measurement Level (kHz)	Required Limit (kHz)	Result
3	2422	36534.8	≥ 500	Pass
6	2437	36503.8	≥ 500	Pass
9	2452	36516.8	≥ 500	Pass

Channel 3

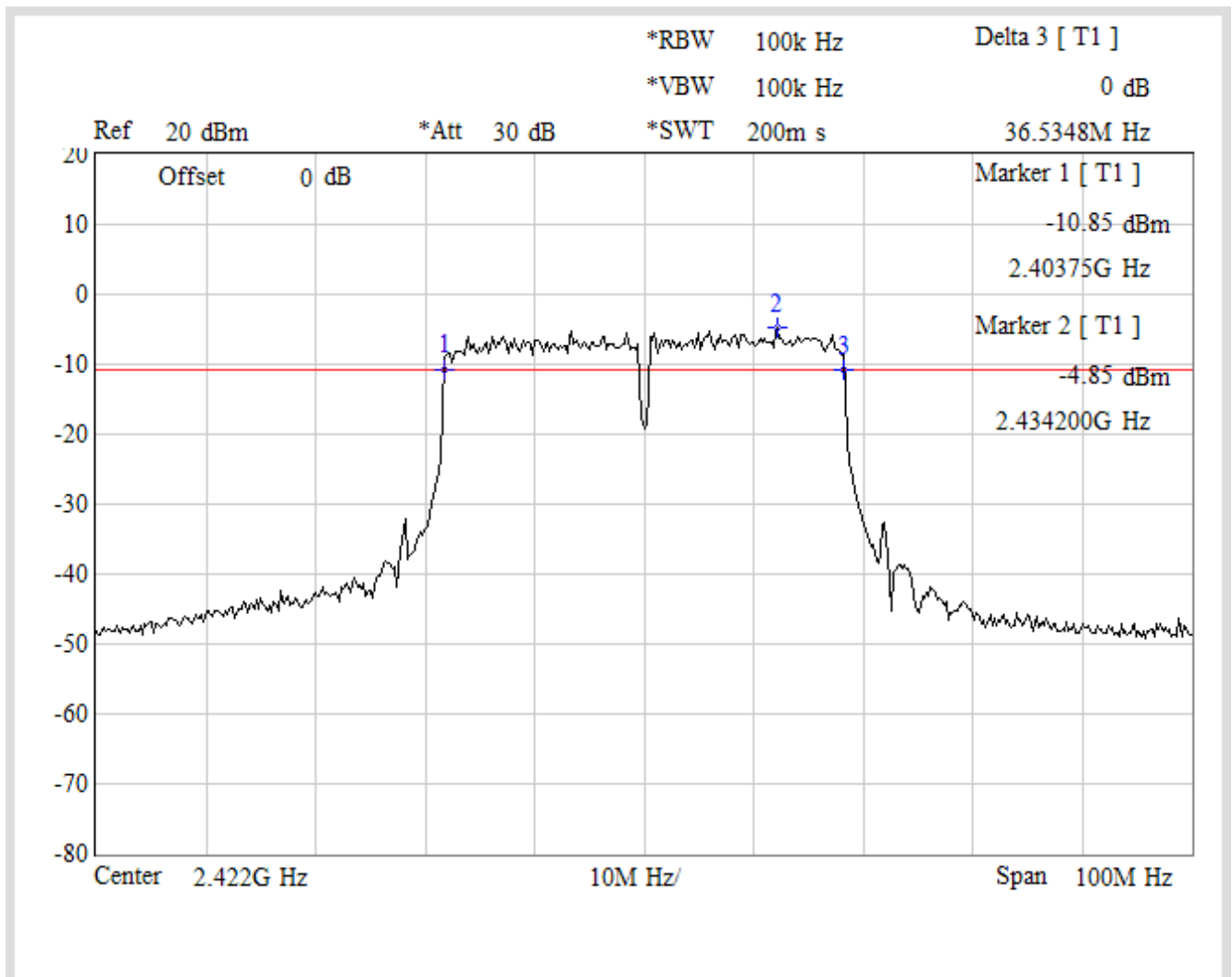

Channel 6

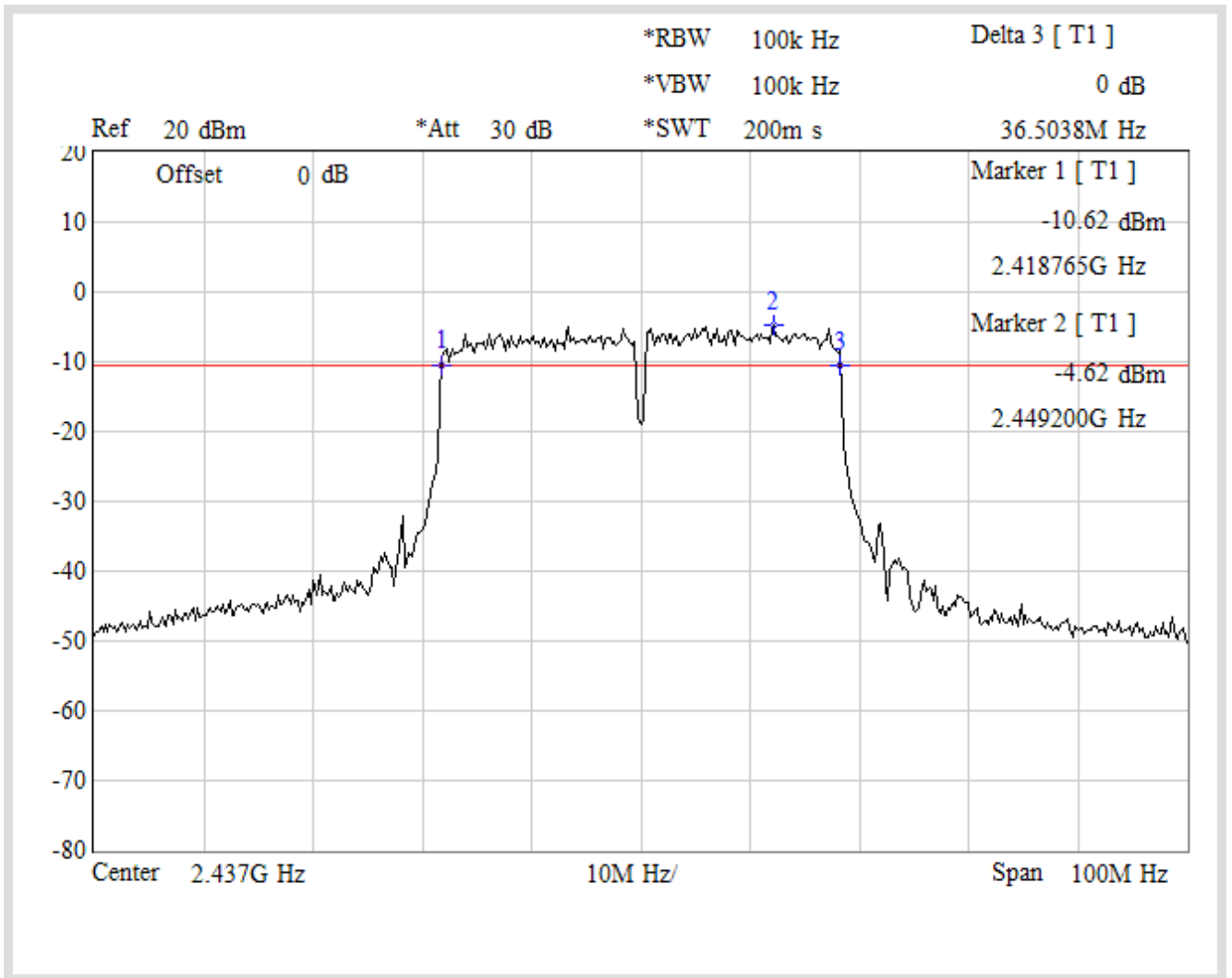

Channel 9

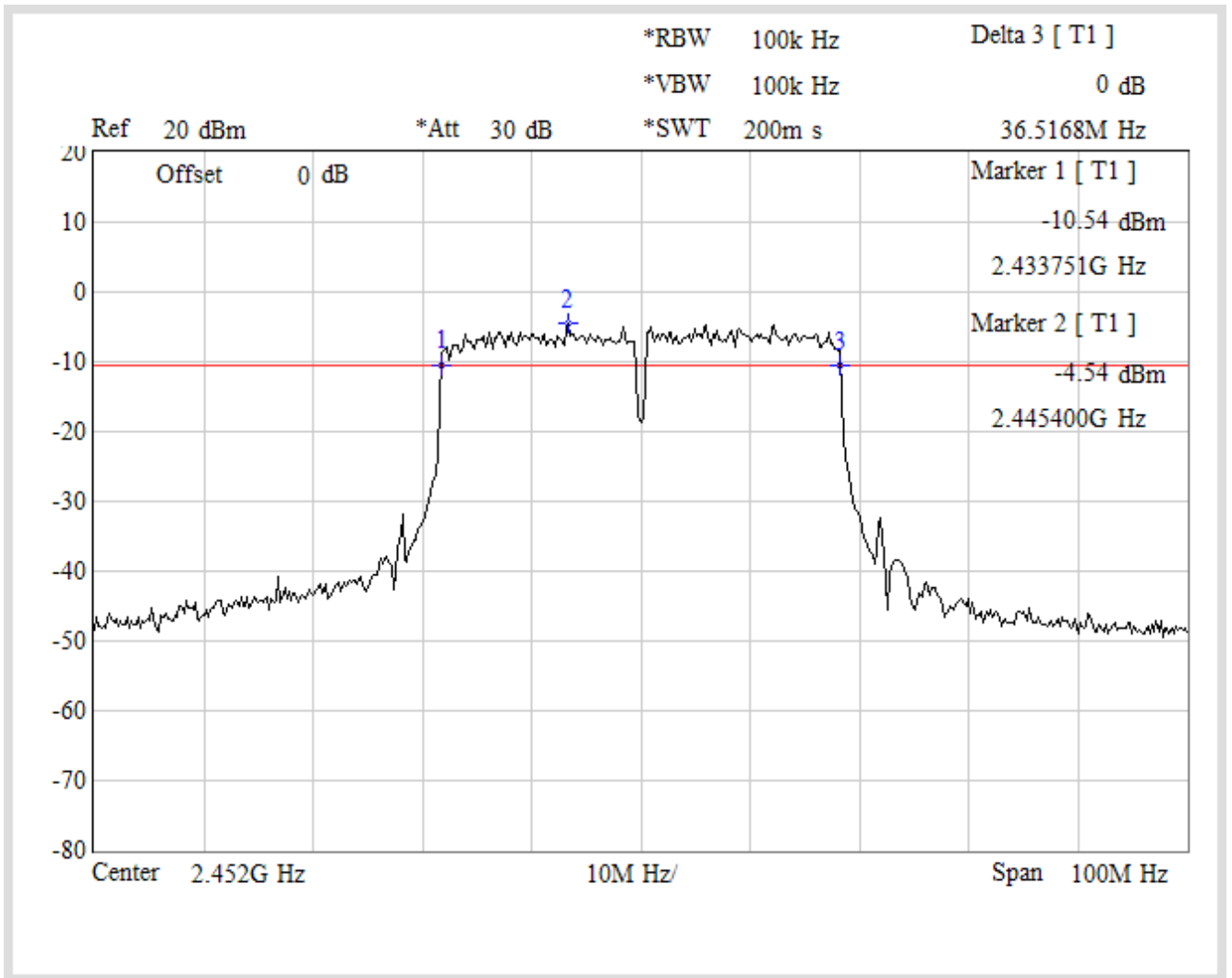

8. 99% Occupied Bandwidth

8.1. Test Equipment

The following test equipments are used during the radiated emission tests:

Item	Equipment	Manufacturer	Model No. / Serial No.	Last Cal.
1	Spectrum Analyzer	R & S	FSP / 100561	Mar., 2008
2	No.1 OATS			Sep., 2007

Note: 1. All equipments that need to calibrate are with calibration period of 1 year.

8.2. Test Setup

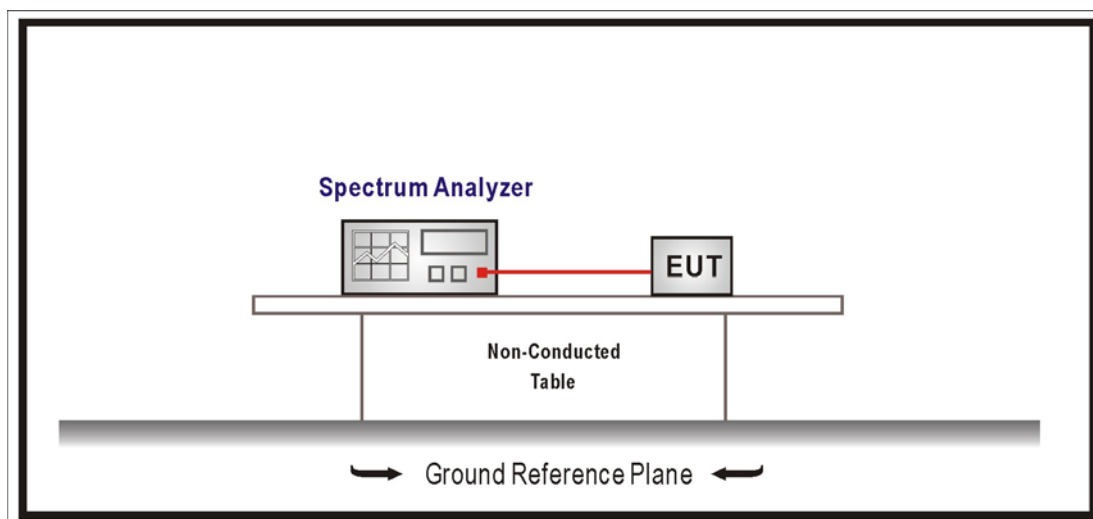

8.3. Limits

No Required

8.4. Uncertainty

± 150Hz

8.5. Test Result

Product	WIRELESS G ADSL2+ MODEM ROUTER		
Test Item	Occupied Bandwidth		
Test Mode	Transmit		
Date of Test	2008/06/30	Test Site	No.1 OATS

Channel No.	Frequency (MHz)	Measurement Level (kHz)	Required Limit (kHz)	Result
1	2412.00	15000	>=500	Pass
6	2437.00	15200	>=500	Pass
11	2462.00	15000	>=500	Pass

Channel 1

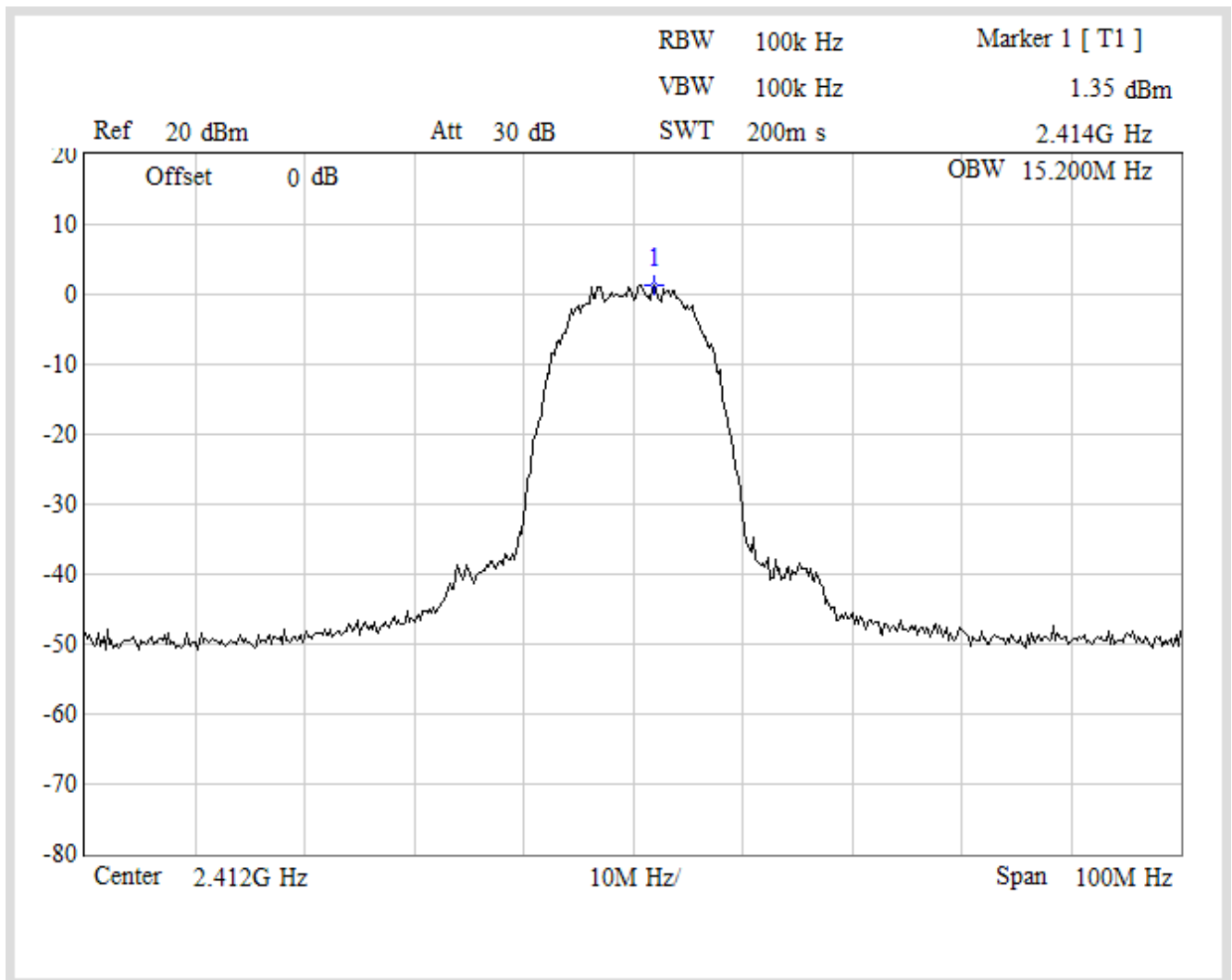

Channel 6

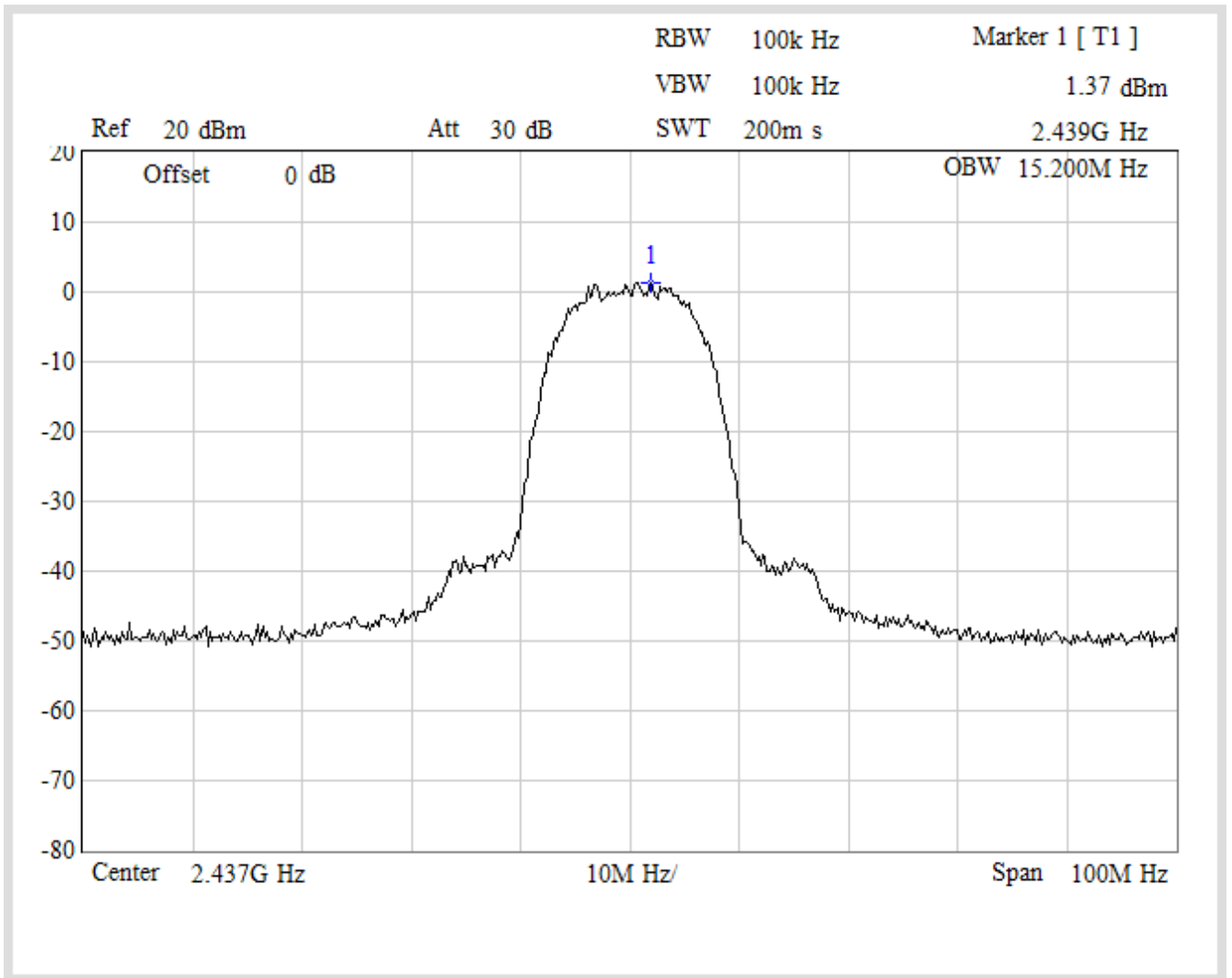

Channel 11

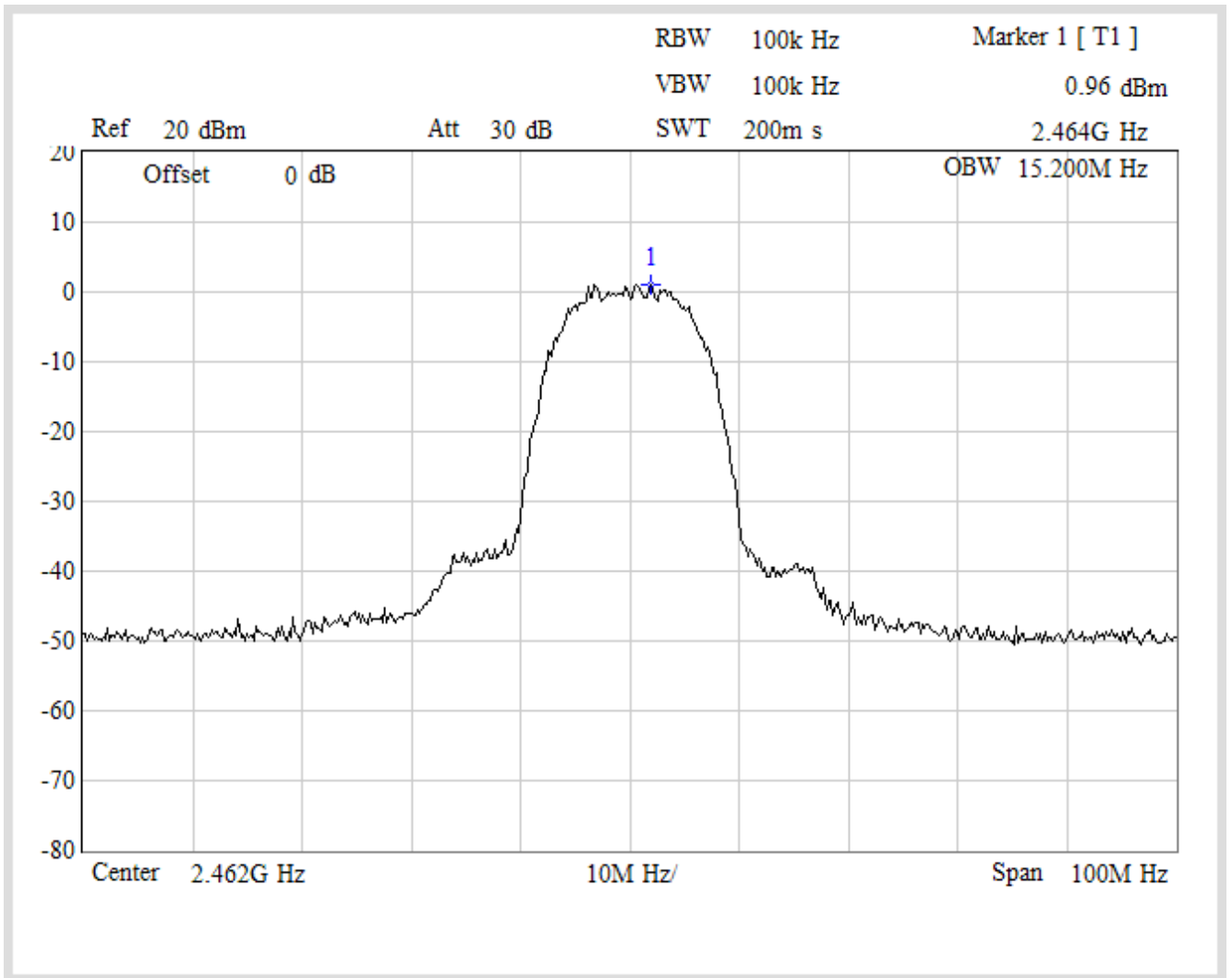

Product	WIRELESS G ADSL2+ MODEM ROUTER		
Test Item	Occupied Bandwidth		
Test Mode	Transmit		
Date of Test	2008/06/30	Test Site	No.1 OATS

IEEE 802.11g				
Channel No.	Frequency (MHz)	Measurement Level (kHz)	Required Limit (kHz)	Result
1	2412.00	16600	>=500	Pass
6	2437.00	16600	>=500	Pass
11	2462.00	16600	>=500	Pass

Channel 1

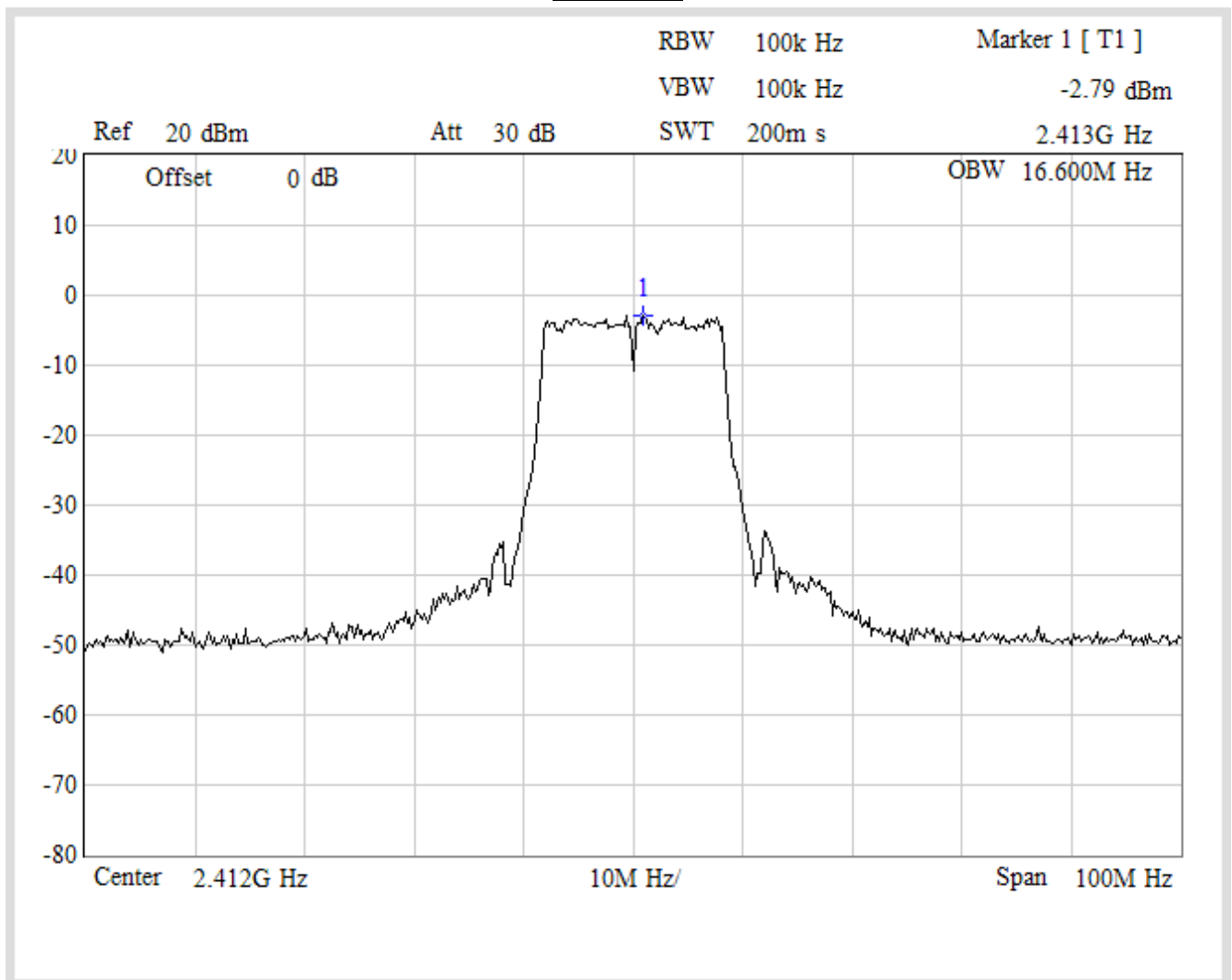

Channel 6

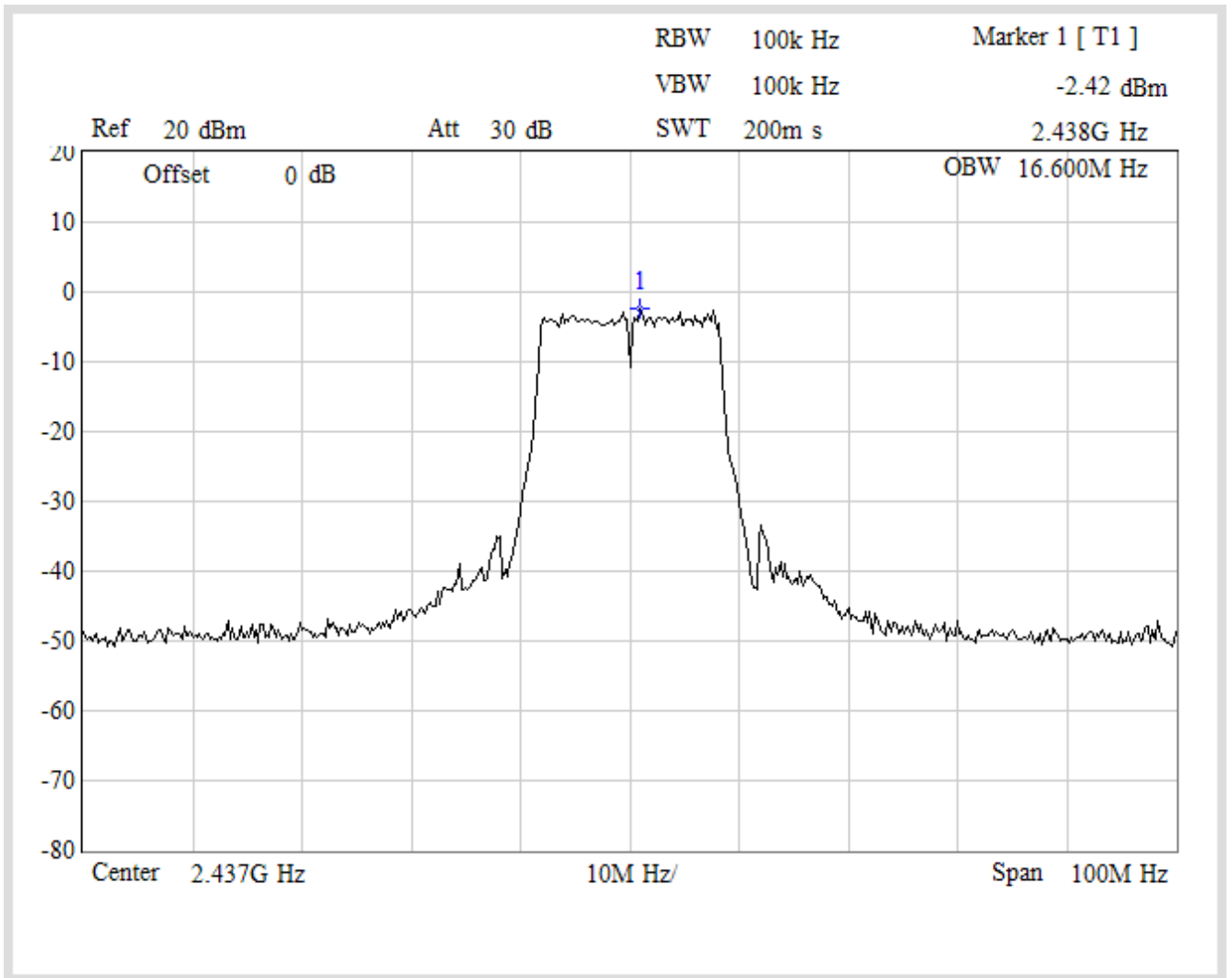

Channel 11

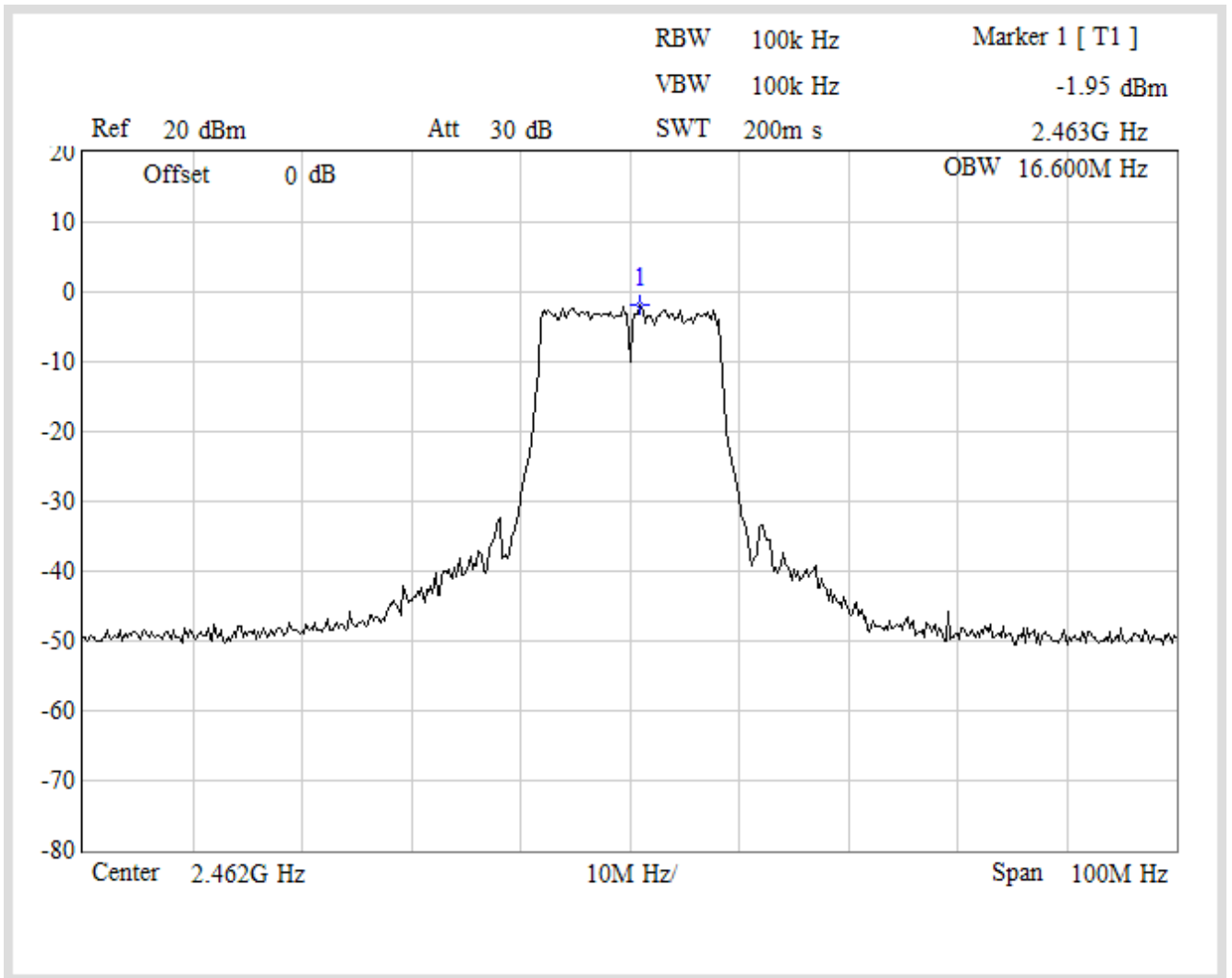

Product	WIRELESS G ADSL2+ MODEM ROUTER		
Test Item	Occupied Bandwidth		
Test Mode	Transmit		
Date of Test	2008/06/30	Test Site	No.1 OATS

IEEE 802.11n (ANT A (20MHz))				
Channel No.	Frequency (MHz)	Measurement Level (kHz)	Required Limit (kHz)	Result
1	2412	17600	>=500	Pass
6	2437	17600	>=500	Pass
11	2462	17600	>=500	Pass

Channel 1

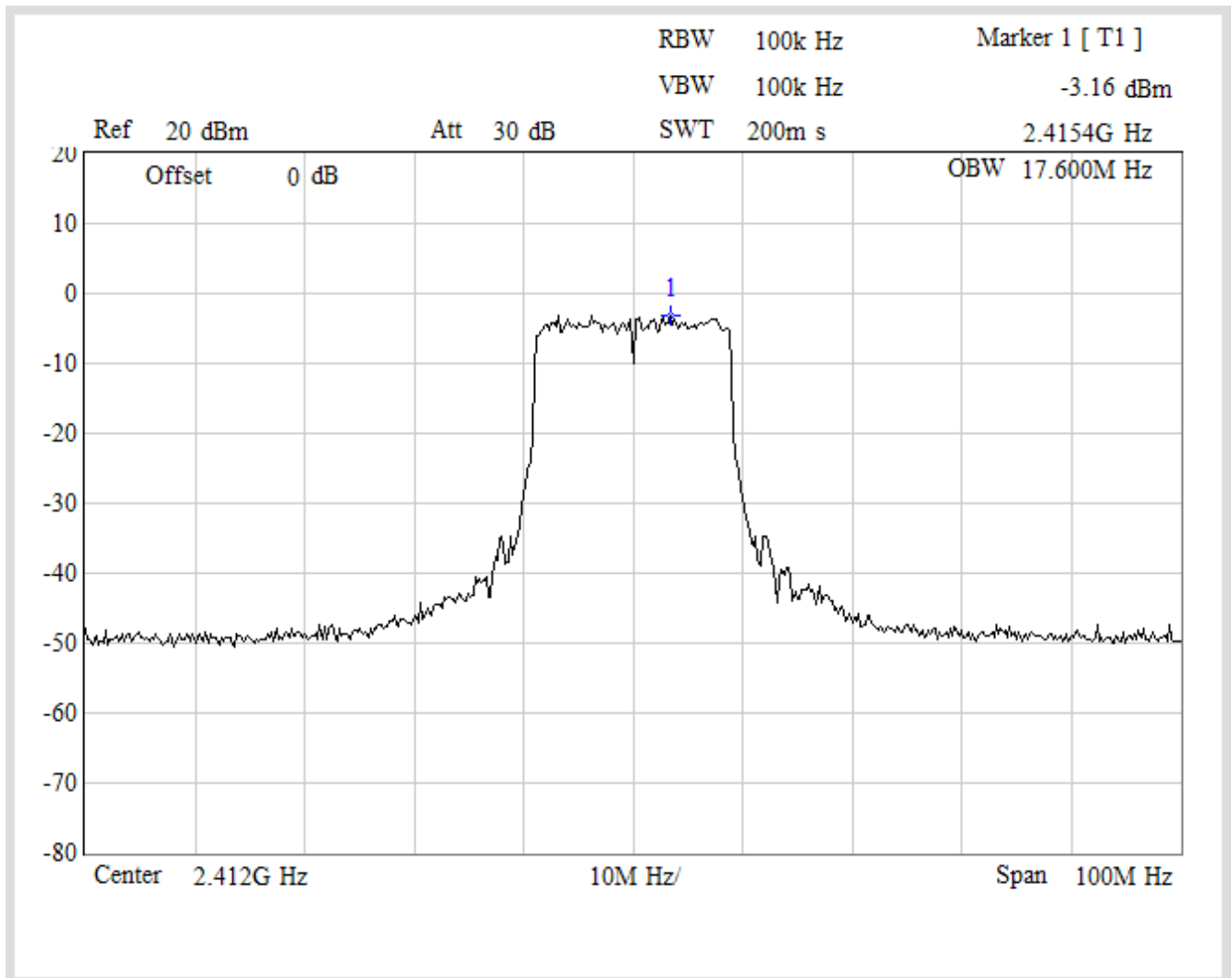

Channel 6

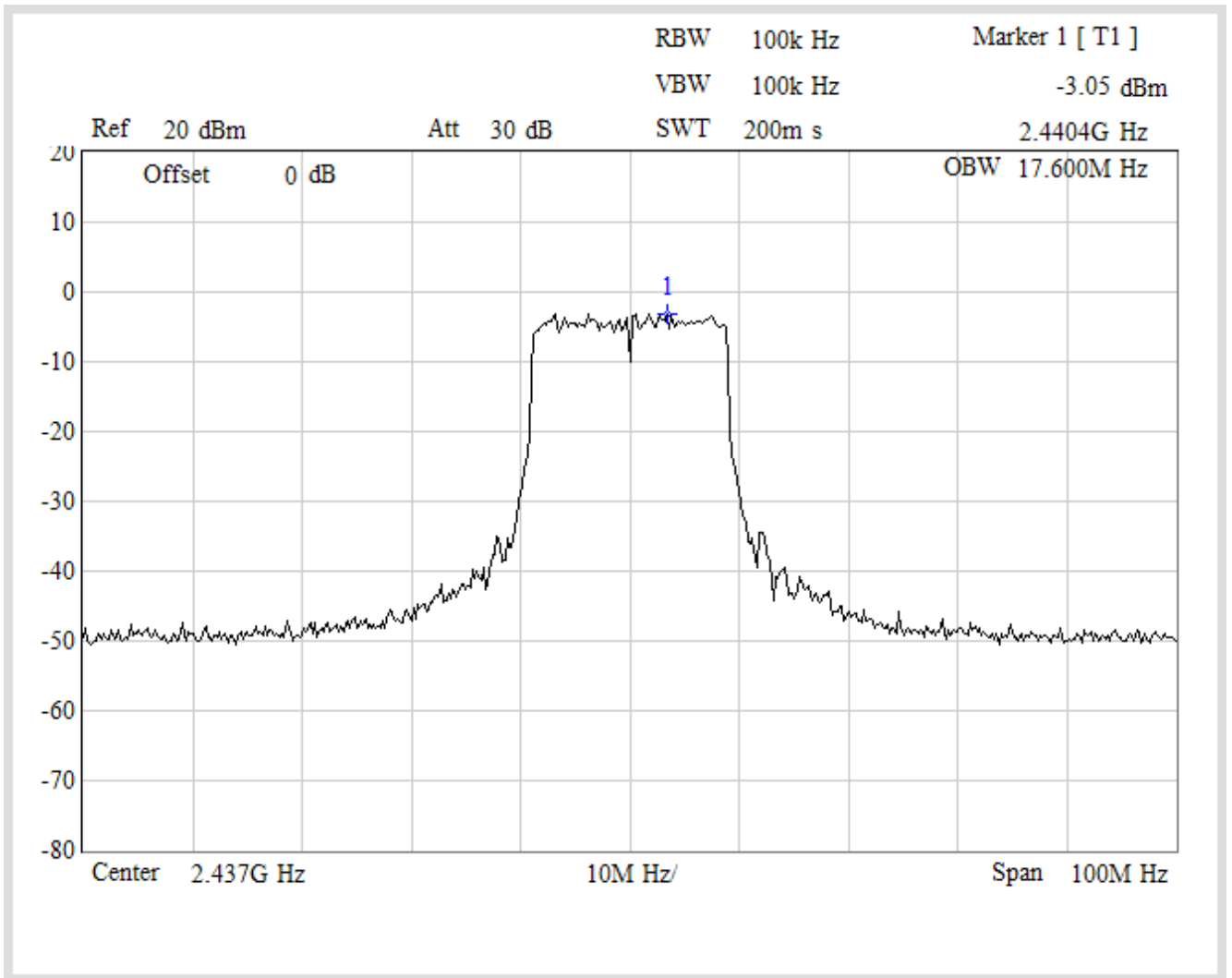

Channel 11

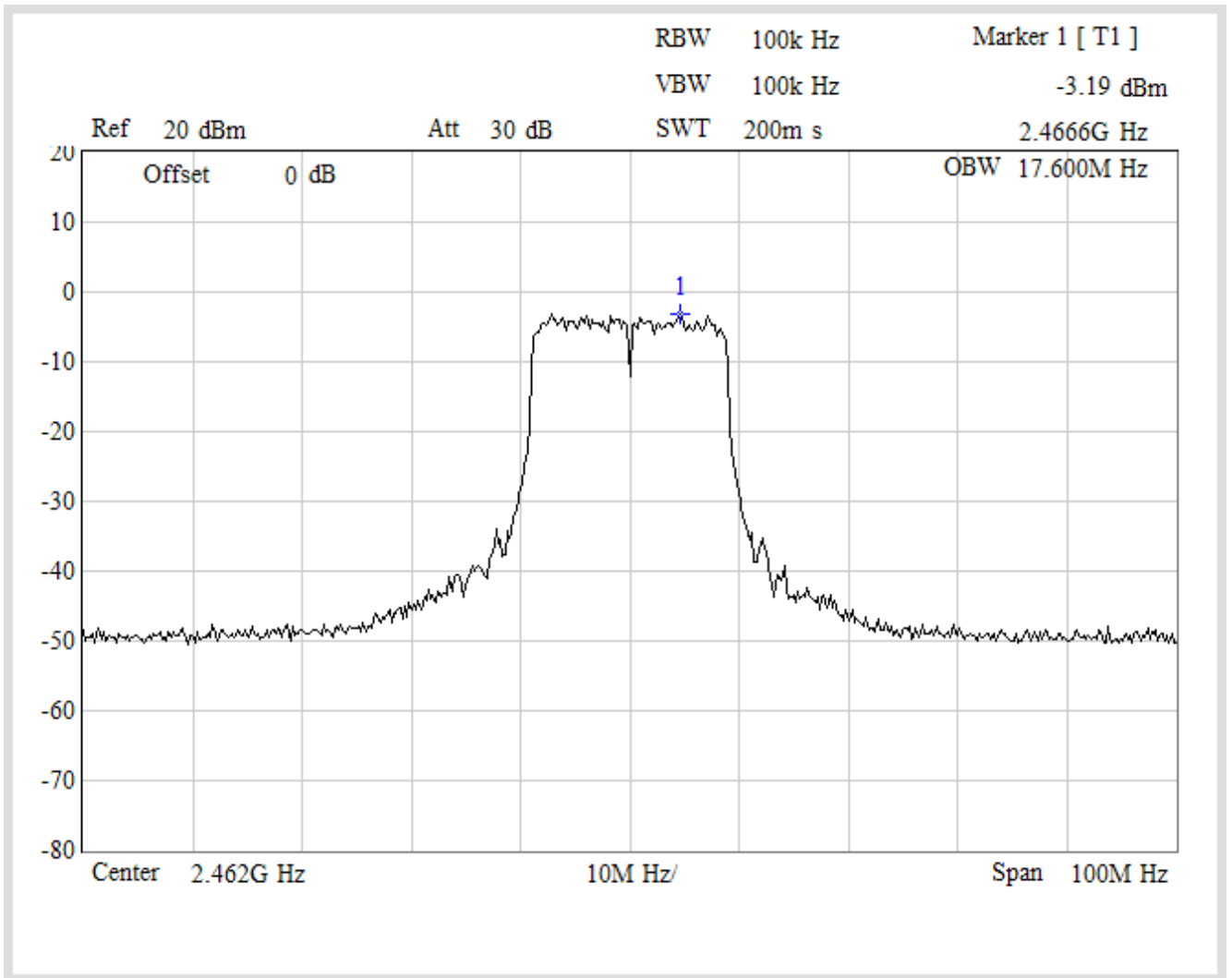

Product	WIRELESS G ADSL2+ MODEM ROUTER		
Test Item	Occupied Bandwidth		
Test Mode	Transmit		
Date of Test	2008/06/30	Test Site	No.1 OATS

IEEE 802.11n (ANT B (20MHz))				
Channel No.	Frequency (MHz)	Measurement Level (kHz)	Required Limit (kHz)	Result
1	2412	17800	>=500	Pass
6	2437	17800	>=500	Pass
11	2462	17600	>=500	Pass

Channel 1

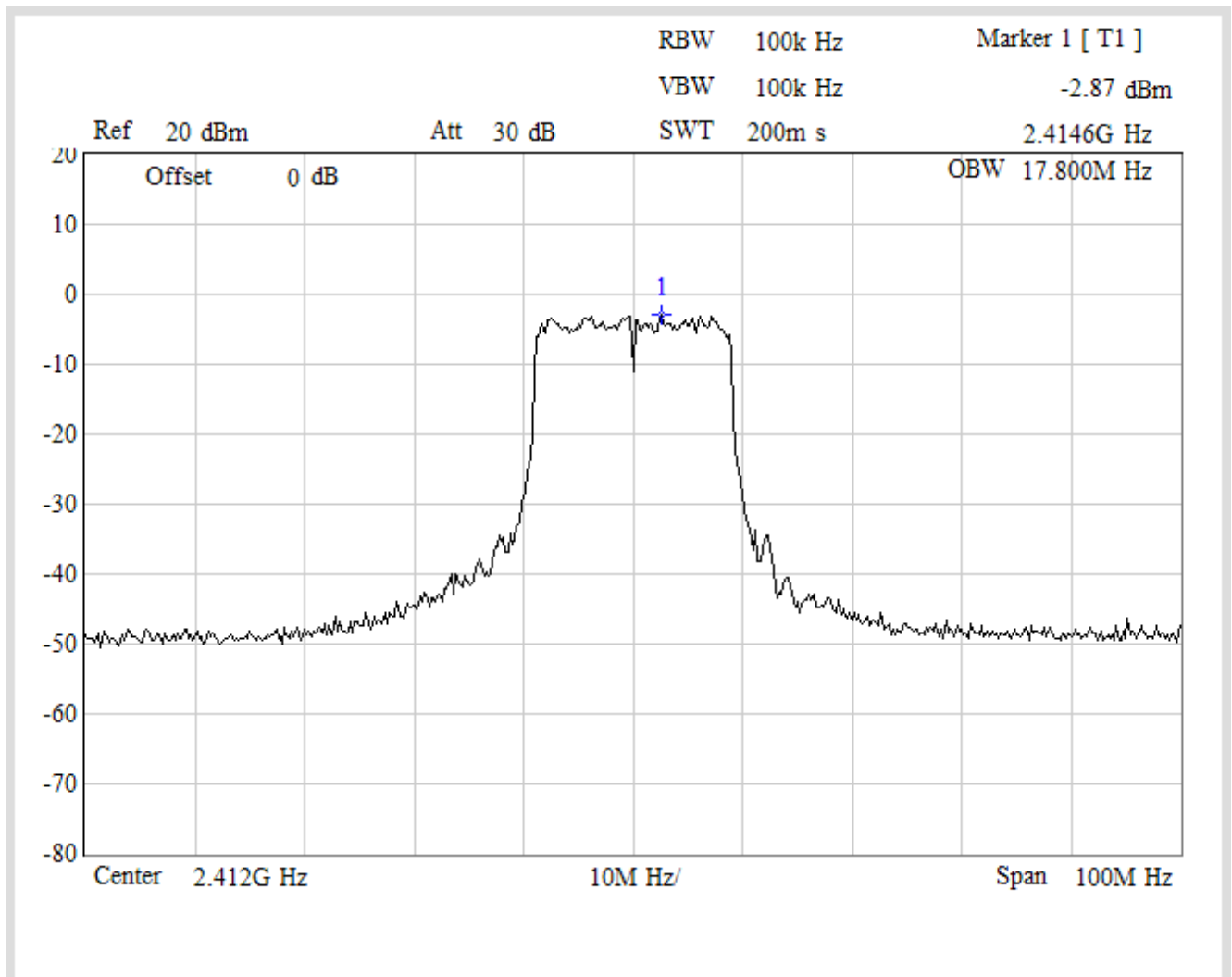

Channel 6

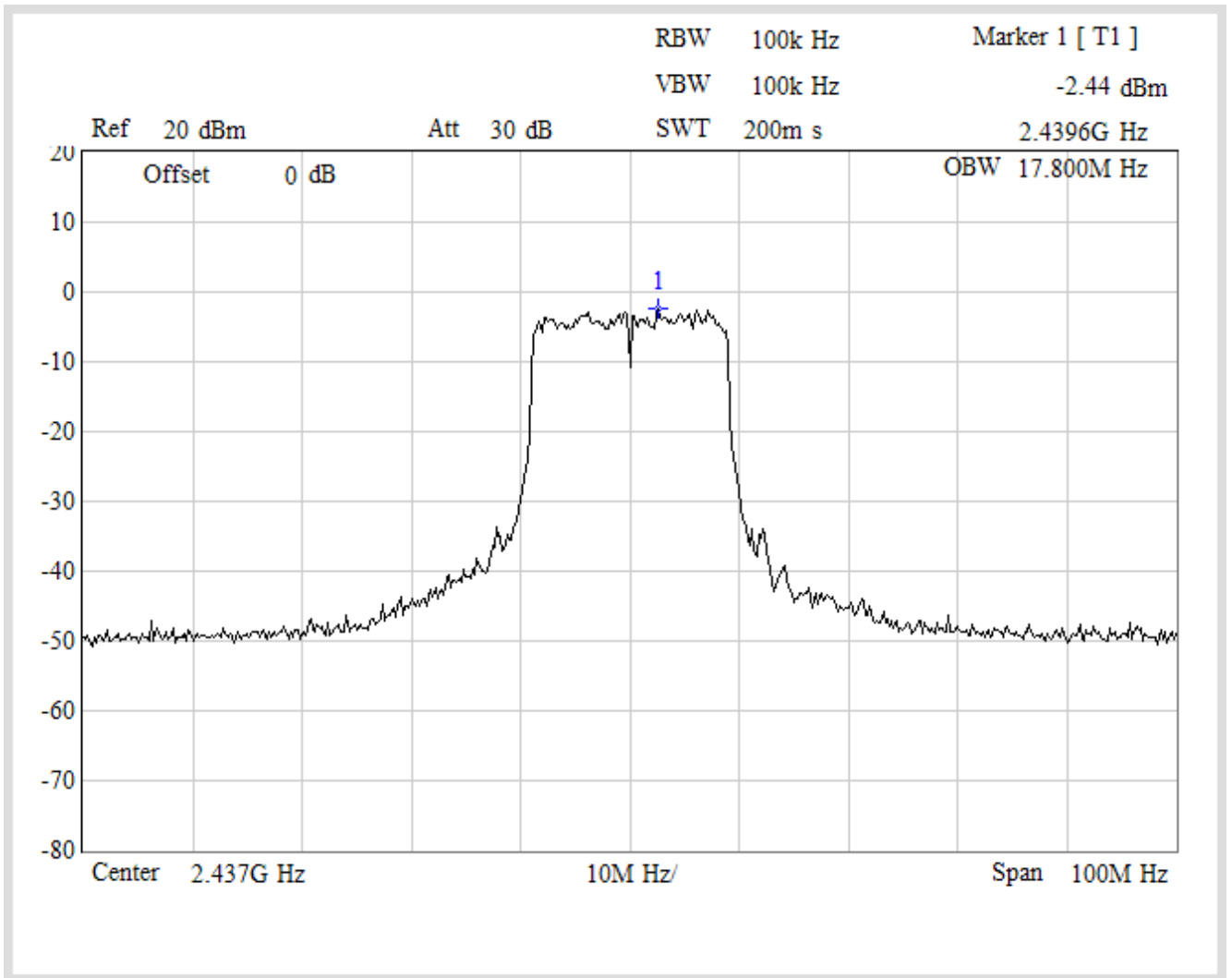

Channel 11

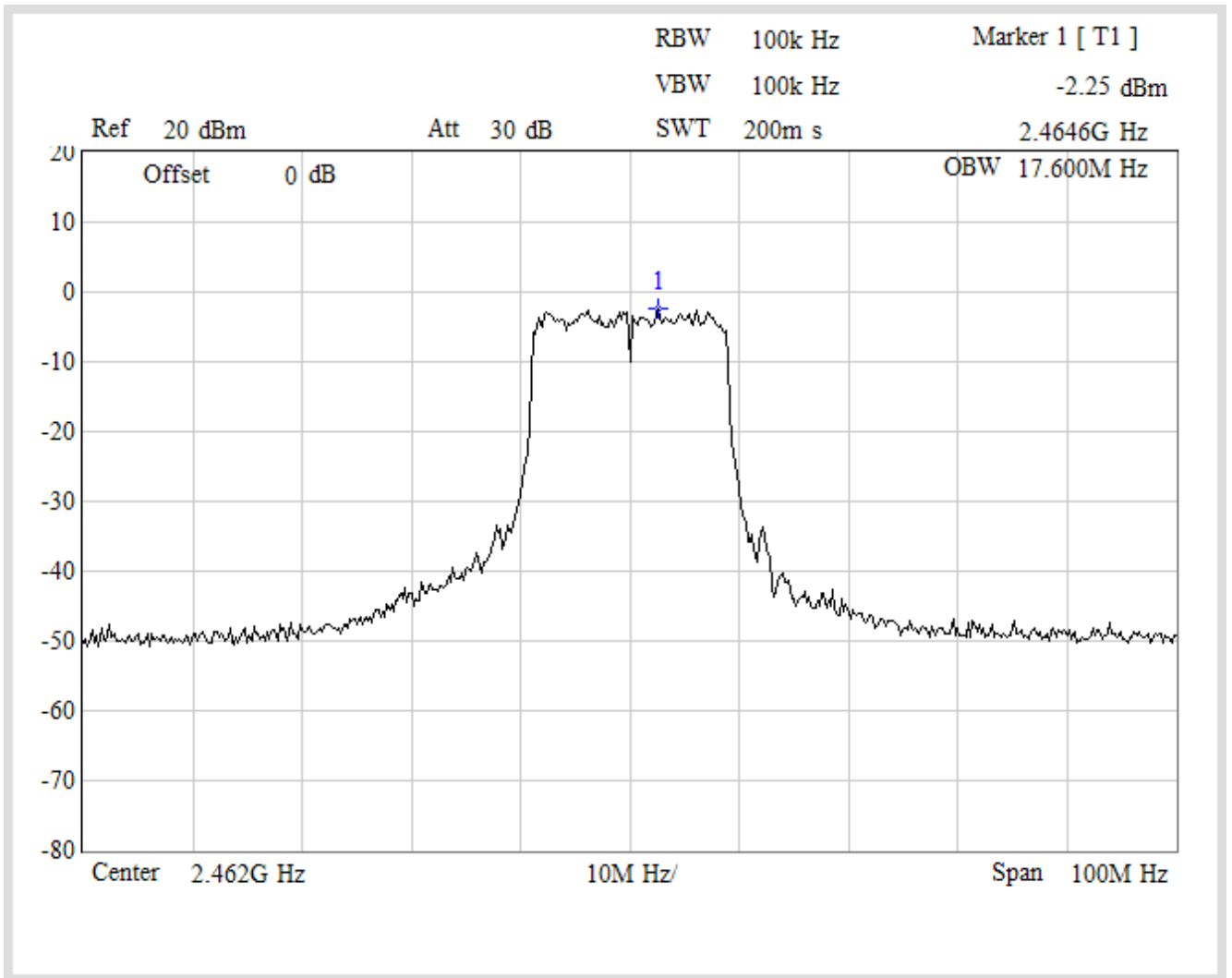

Product	WIRELESS G ADSL2+ MODEM ROUTER		
Test Item	Occupied Bandwidth		
Test Mode	Transmit		
Date of Test	2008/06/30	Test Site	No.1 OATS

IEEE 802.11n (ANT A (40MHz))				
Channel No.	Frequency (MHz)	Measurement Level (kHz)	Required Limit (kHz)	Result
3	2422	36200	>=500	Pass
6	2437	36200	>=500	Pass
9	2452	36000	>=500	Pass

Channel 3

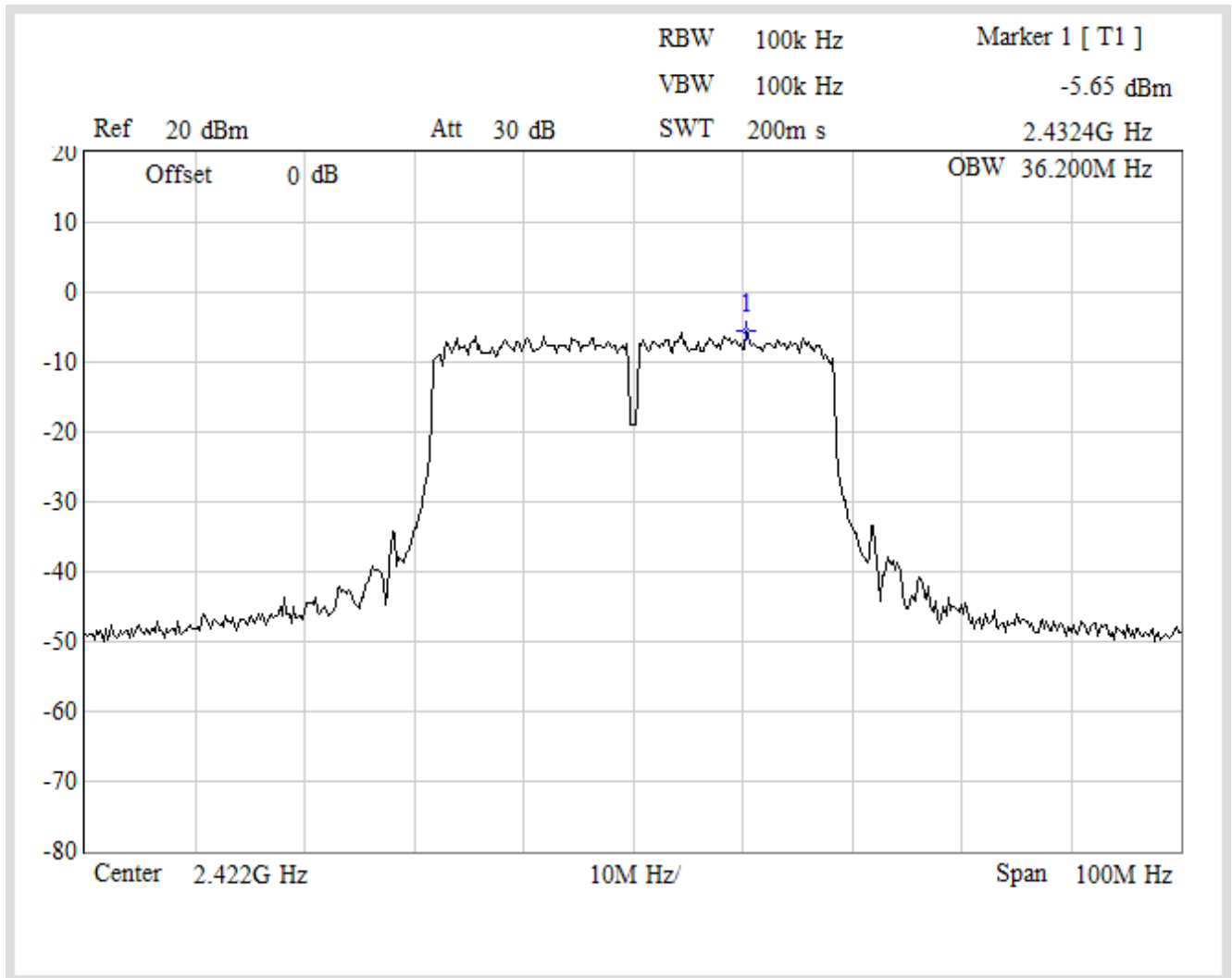

Channel 6

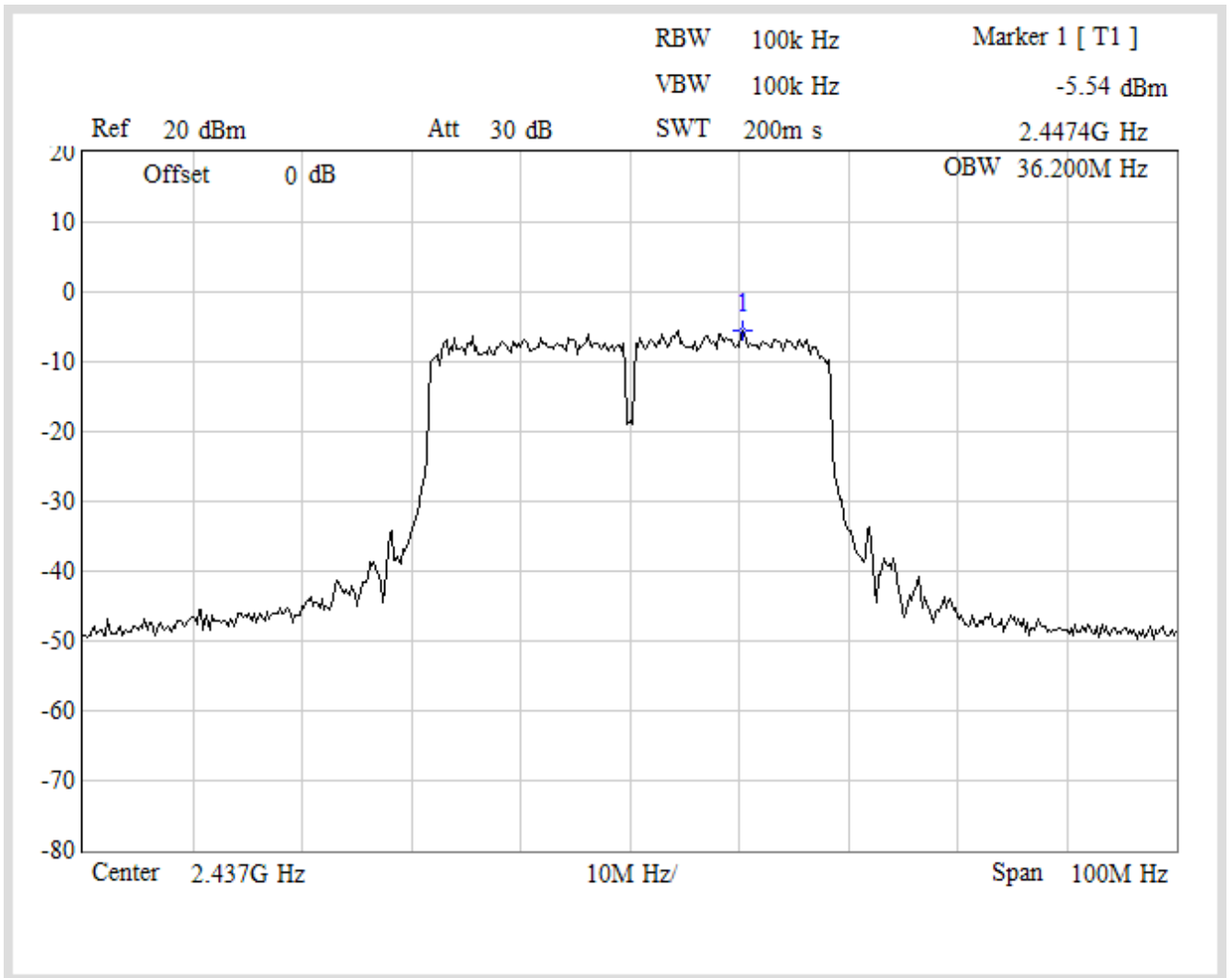

Channel 9

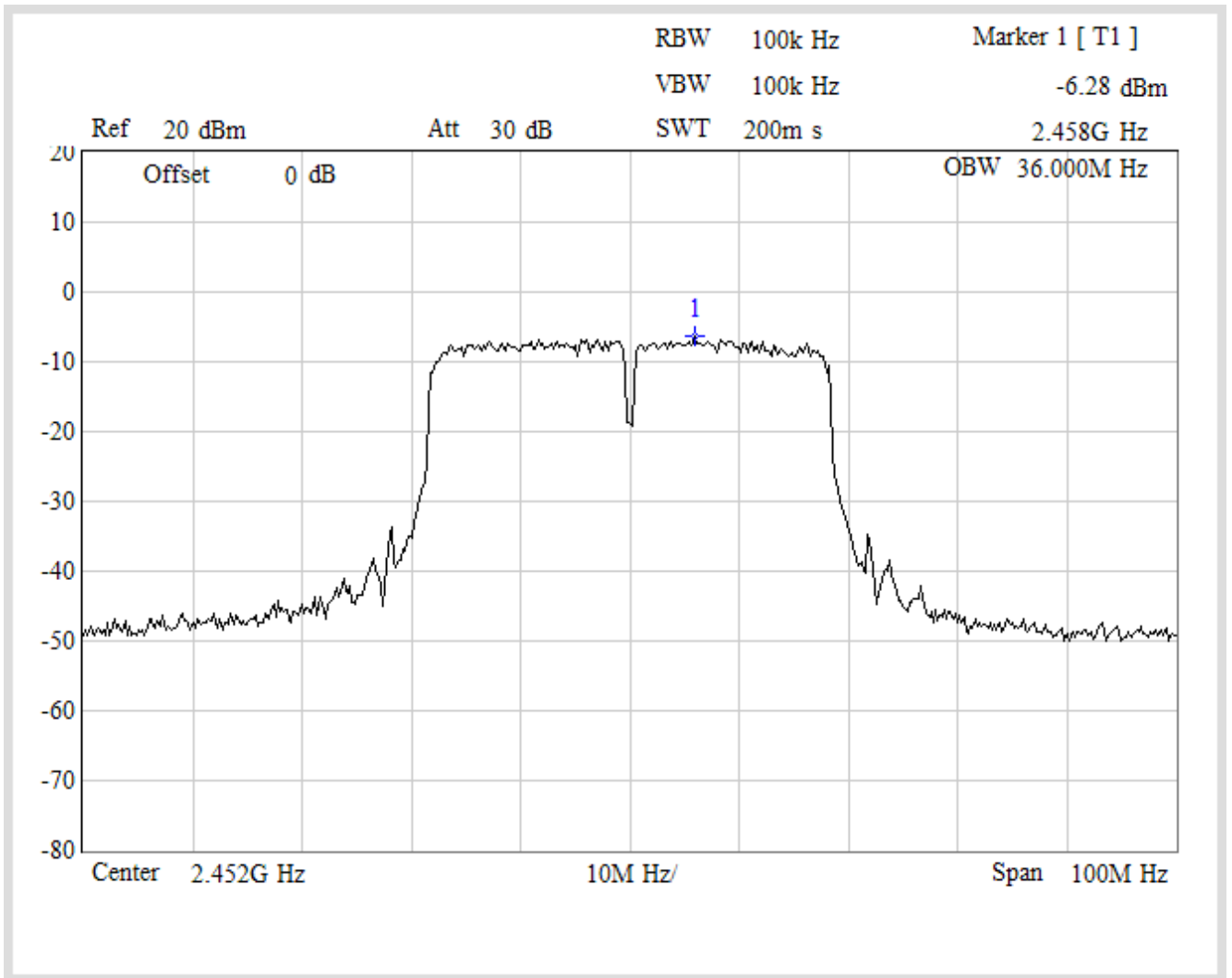

Product	WIRELESS G ADSL2+ MODEM ROUTER		
Test Item	Occupied Bandwidth		
Test Mode	Transmit		
Date of Test	2008/06/30	Test Site	No.1 OATS

IEEE 802.11n (ANT B (40MHz))				
Channel No.	Frequency (MHz)	Measurement Level (kHz)	Required Limit (kHz)	Result
3	2422	36400	>=500	Pass
6	2437	36200	>=500	Pass
9	2452	36200	>=500	Pass

Channel 3

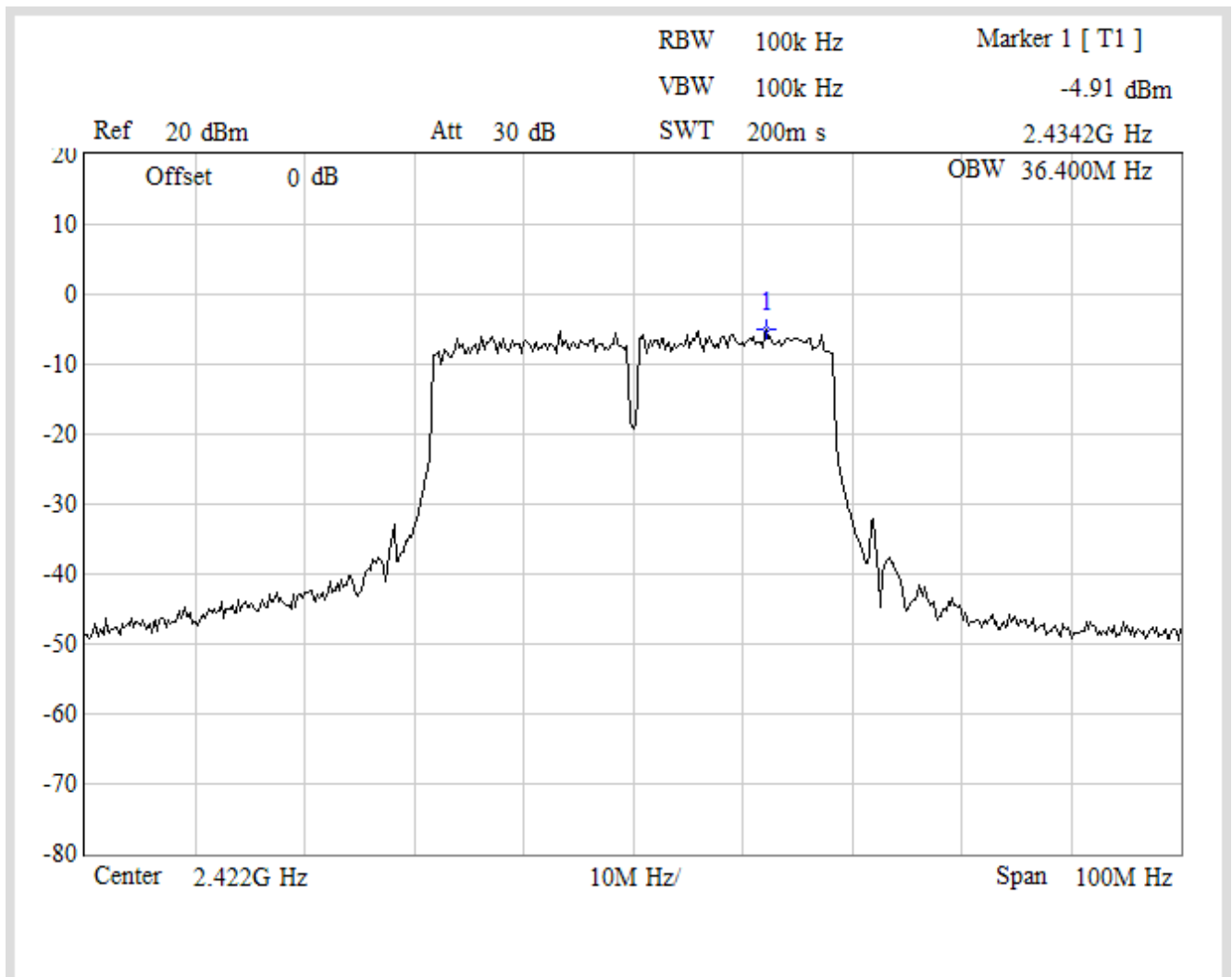

Channel 6

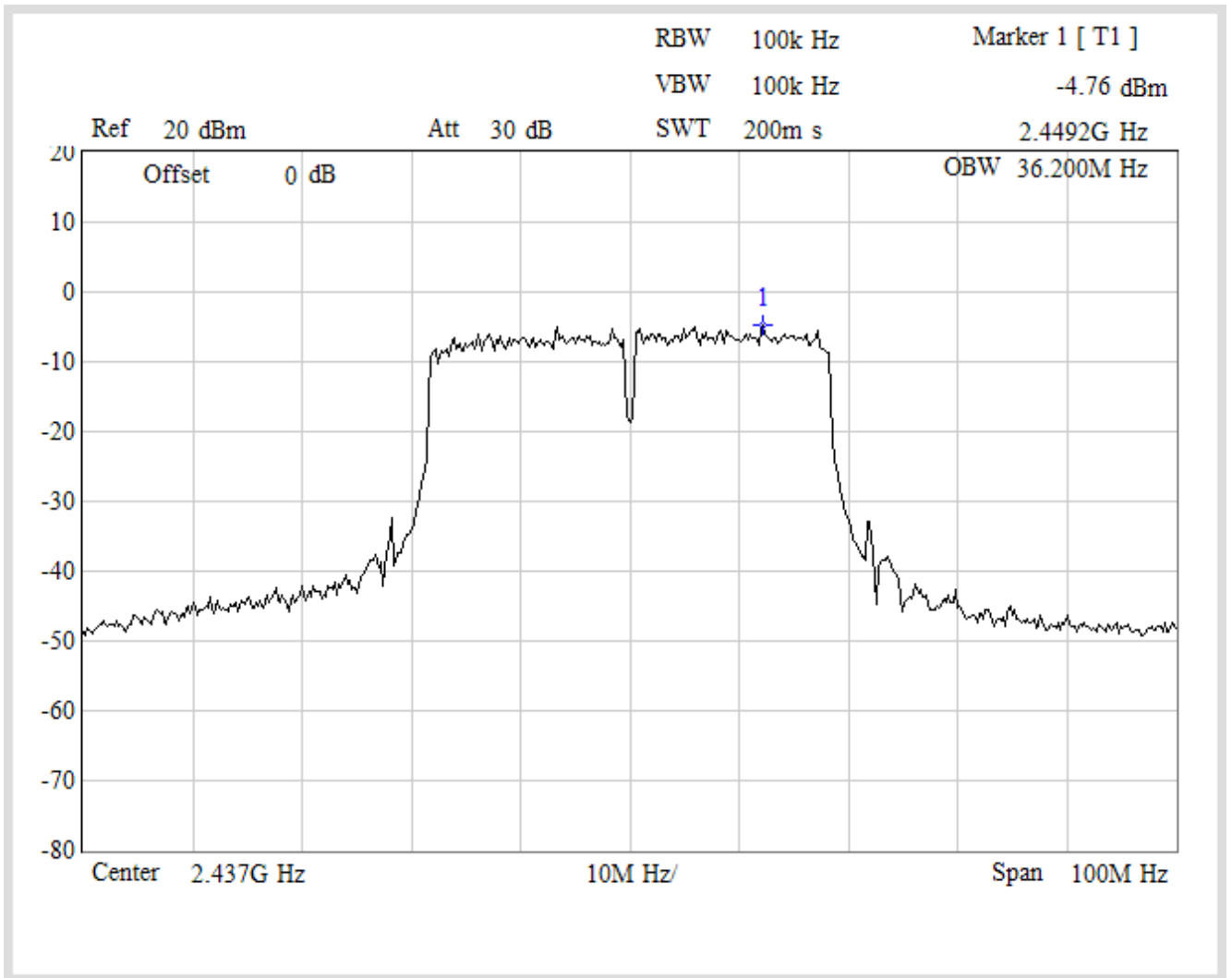

Channel 9

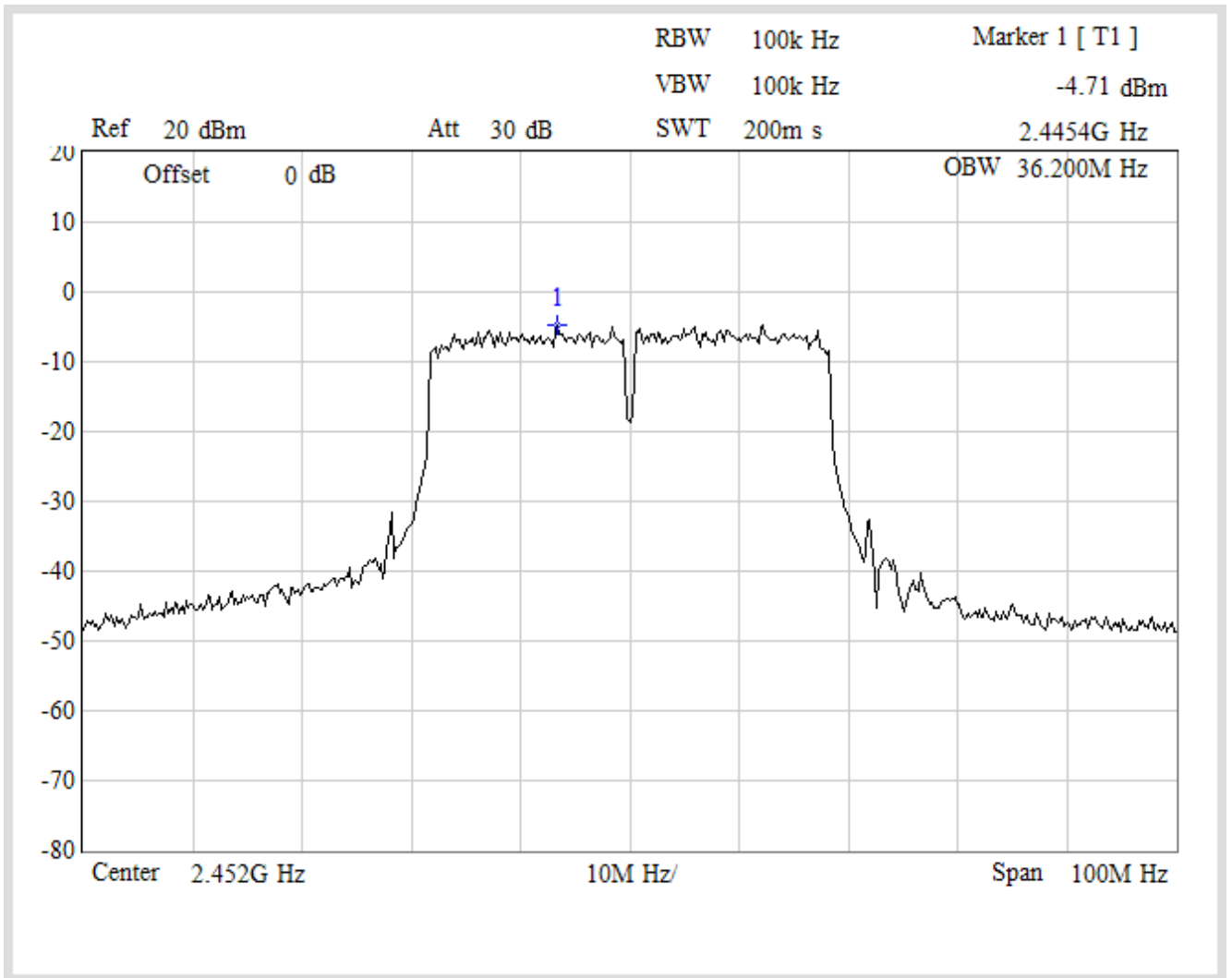

9. Power Density

9.1. Test Equipment

The following test equipment are used during the test:

Item	Equipment	Manufacturer	Model No. / Serial No.	Last Cal.
1	Spectrum Analyzer	R & S	FSP / 100561	Mar., 2008
2	No.1 OATS			Sep., 2007

Note: 1. All equipments that need to calibrate are with calibration period of 1 year.

9.2. Test Setup

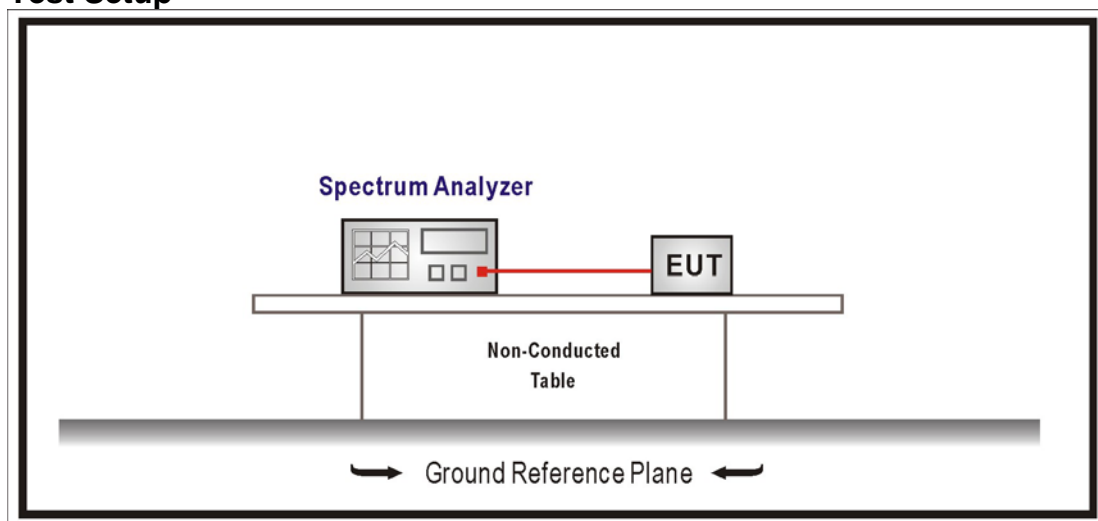

9.3. Limits

According to RSS-210 Issue 7, Annex 8 (June 2007), The transmitted power density averaged over any 1 second interval shall not be greater +8dBm in any 3kHz bandwidth.

9.4. Uncertainty

The measurement uncertainty is defined as $\pm 1.27\text{dB}$.

9.5. Test Result

Product	WIRELESS G ADSL2+ MODEM ROUTER		
Test Item	Power Density		
Test Mode	Transmit		
Date of Test	2008/06/30	Test Site	No.1 OATS

IEEE 802.11b				
Channel No.	Frequency (MHz)	Measure Level (dBm)	Limit (dBm)	Result
1	2412	-10.43	<8	Pass
6	2437	-11.16	<8	Pass
11	2462	-11.15	<8	Pass

Channel 1

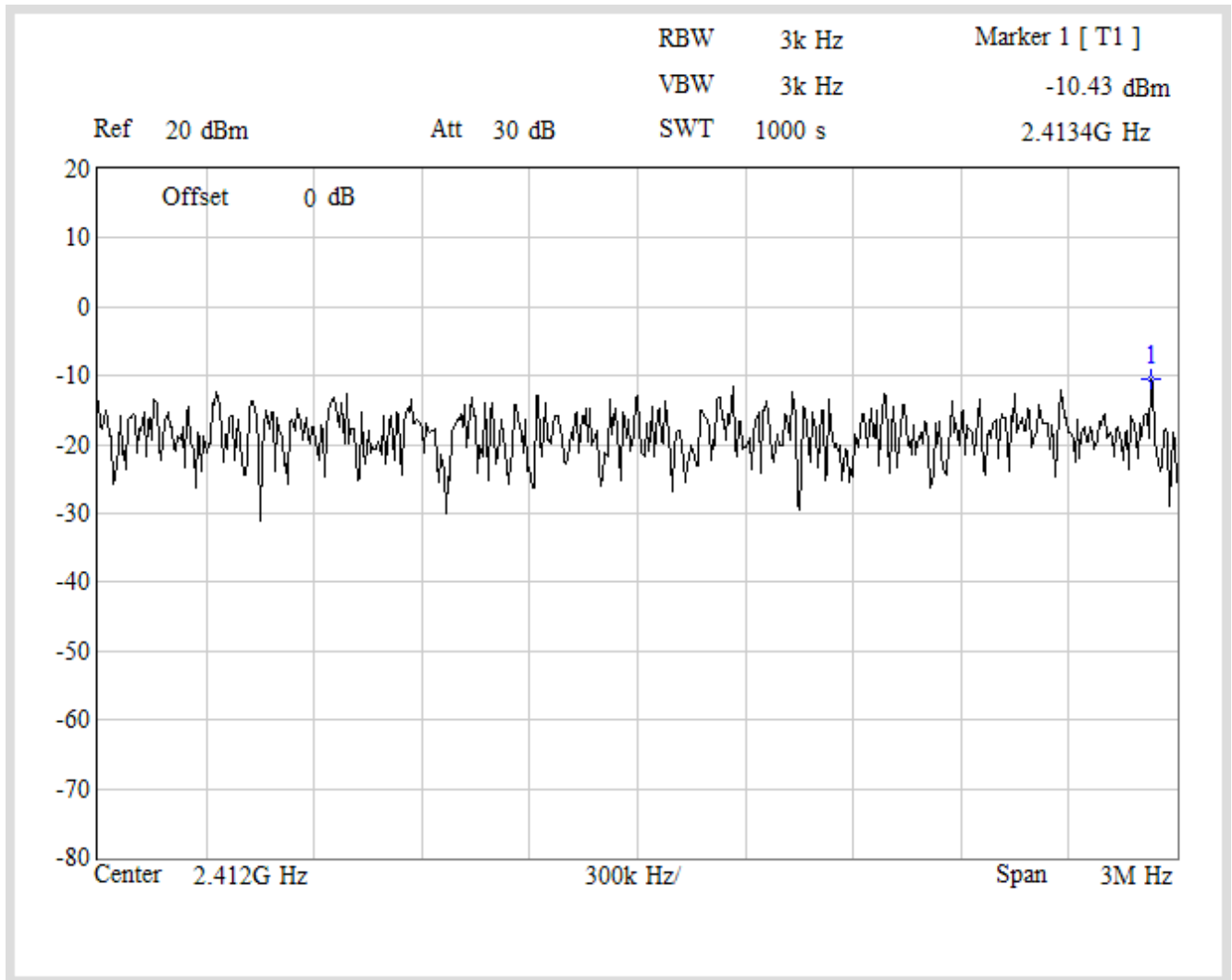

Channel 6

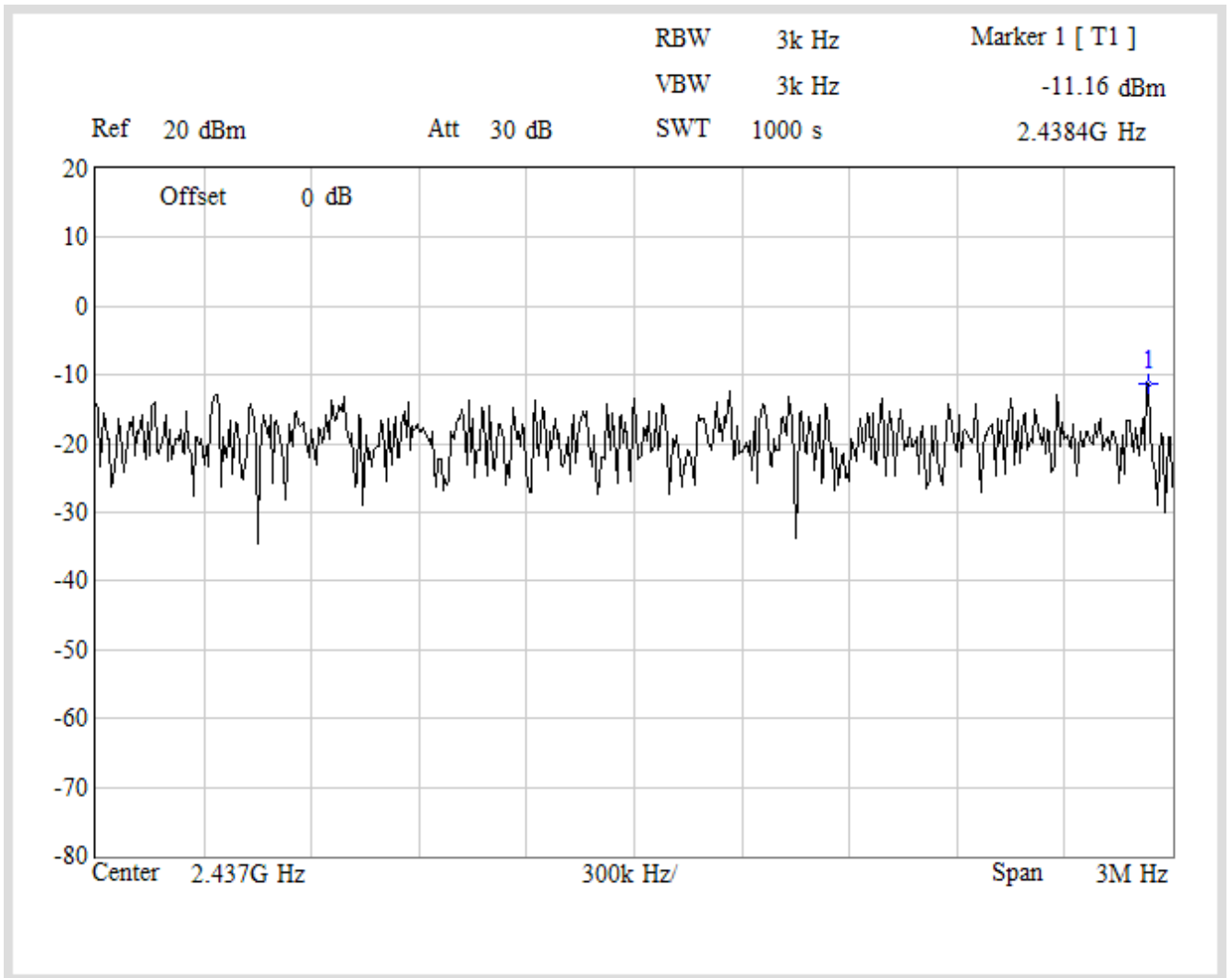

Channel 11

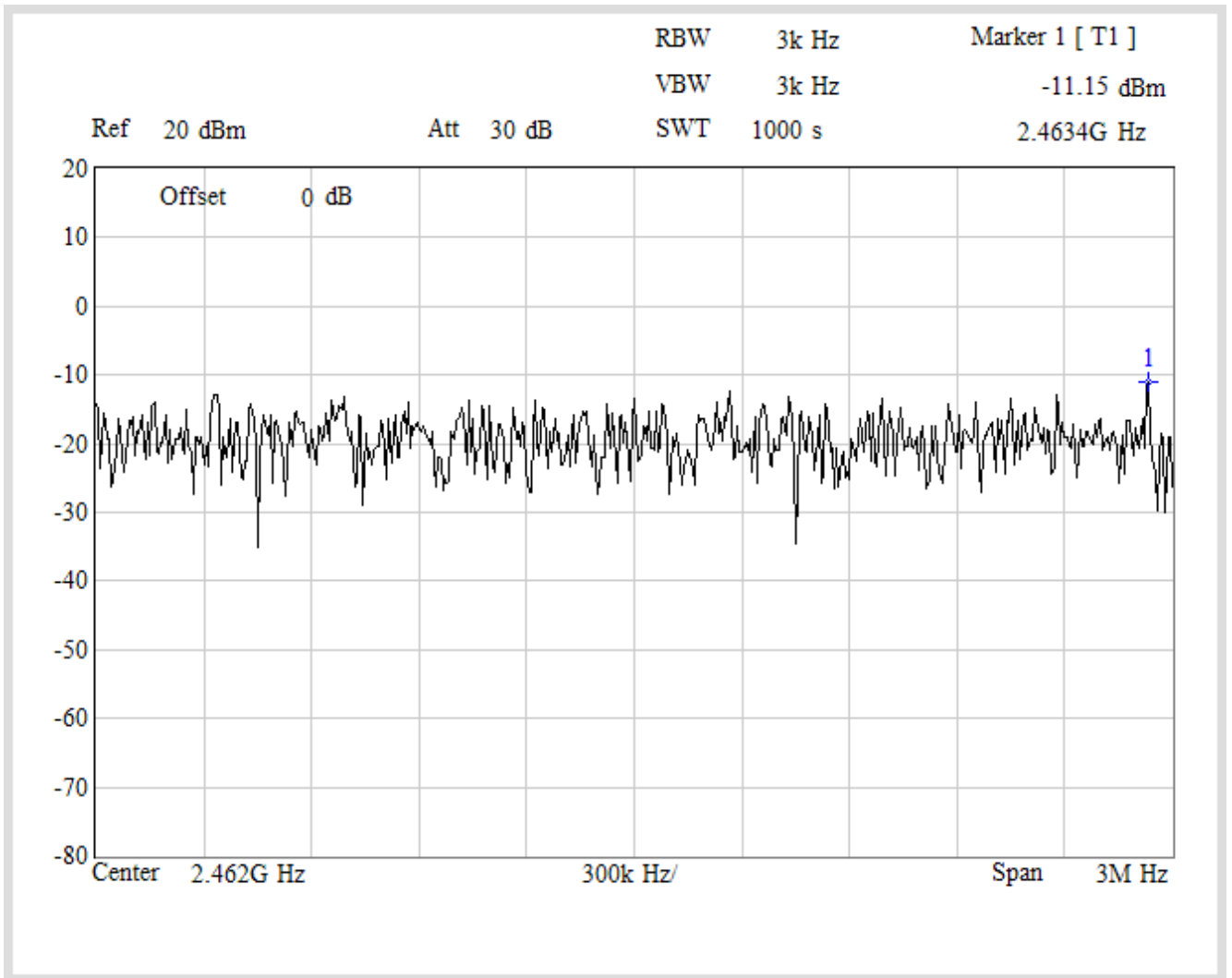

Product	WIRELESS G ADSL2+ MODEM ROUTER		
Test Item	Power Density		
Test Mode	Transmit		
Date of Test	2008/06/30	Test Site	No.1 OATS

IEEE 802.11g				
Channel No.	Frequency (MHz)	Measure Level (dBm)	Limit (dBm)	Result
1	2412	-15.56	<8	Pass
6	2437	-15.87	<8	Pass
11	2462	-15.46	<8	Pass

Channel 1

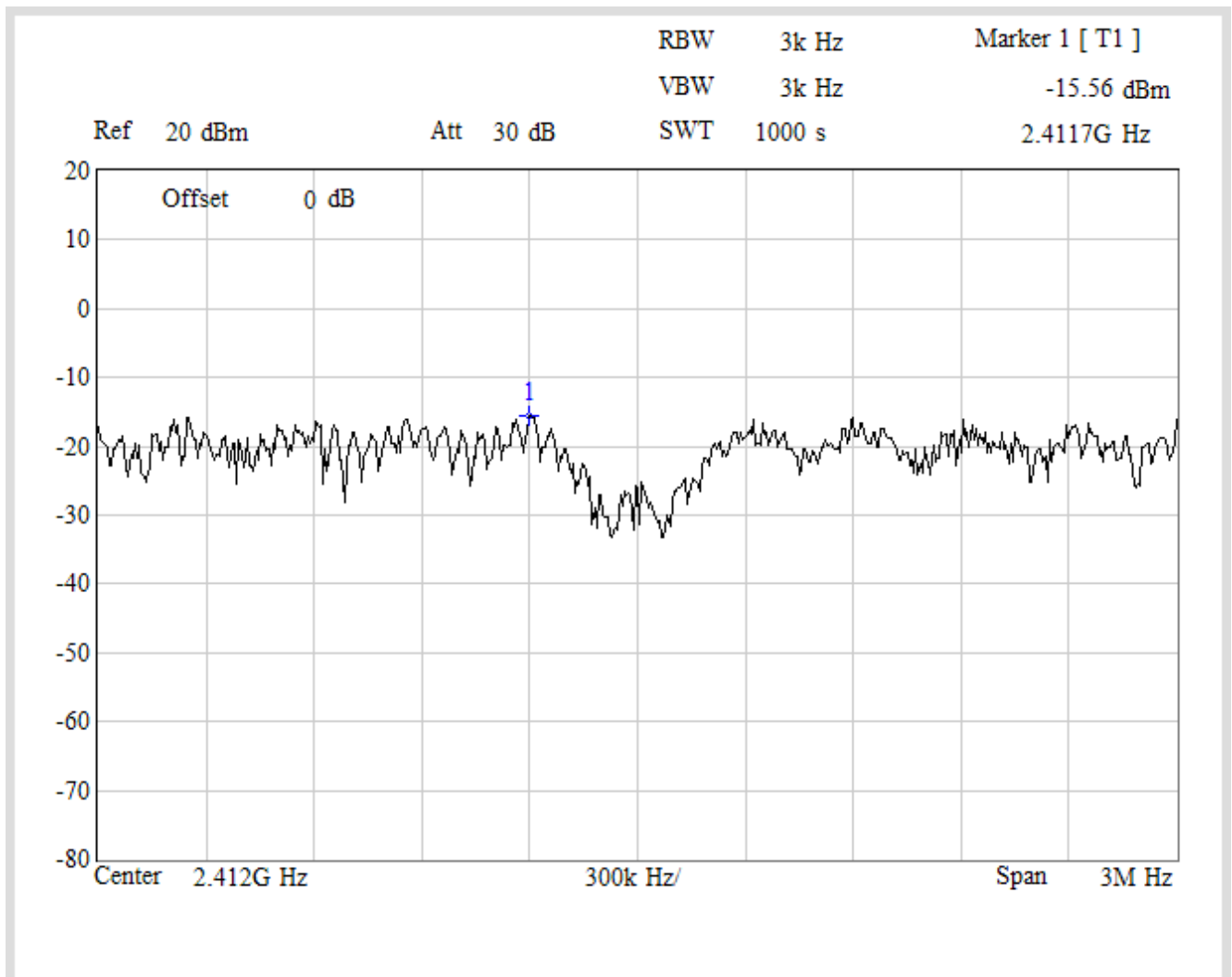

Channel 6

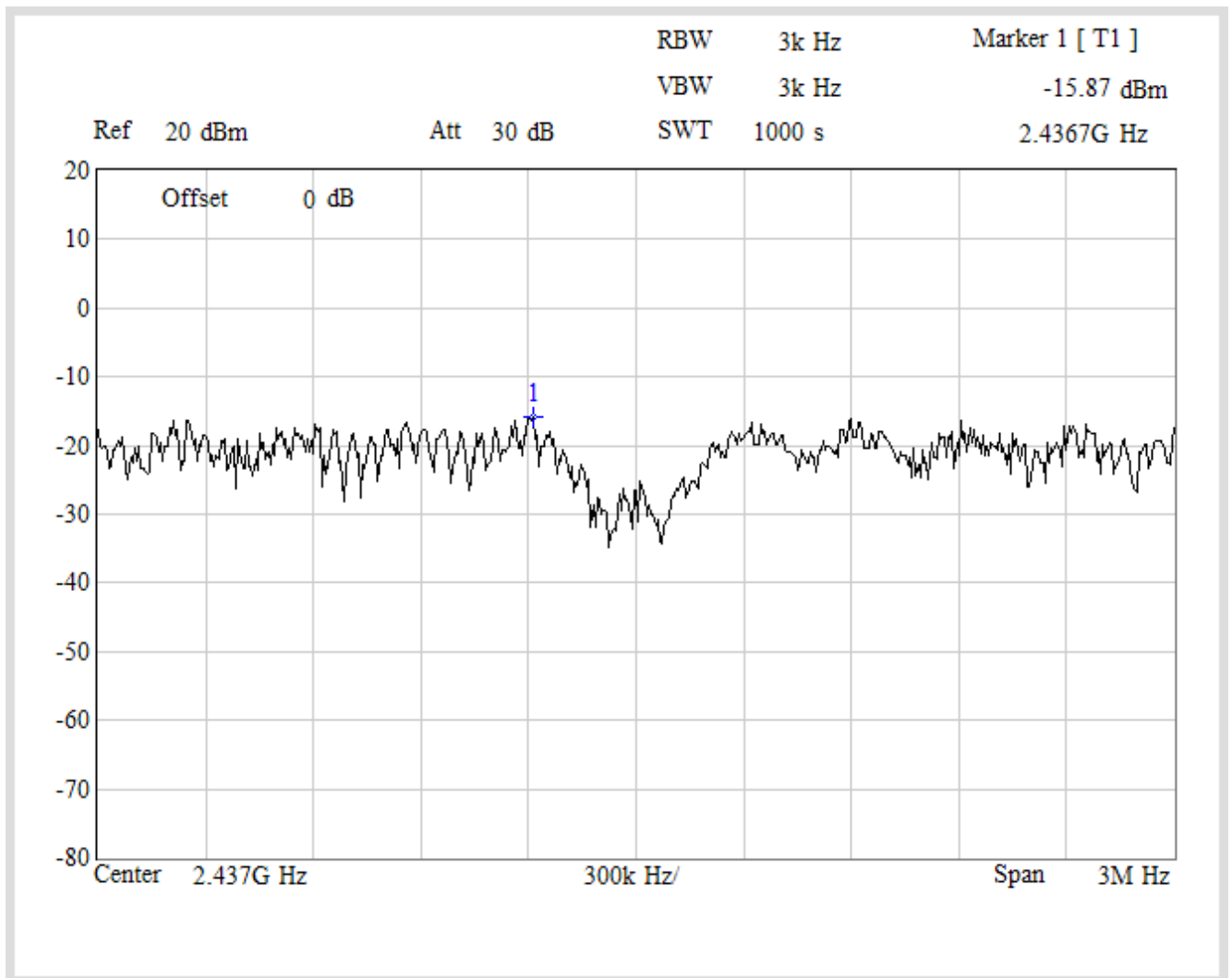

Channel 11

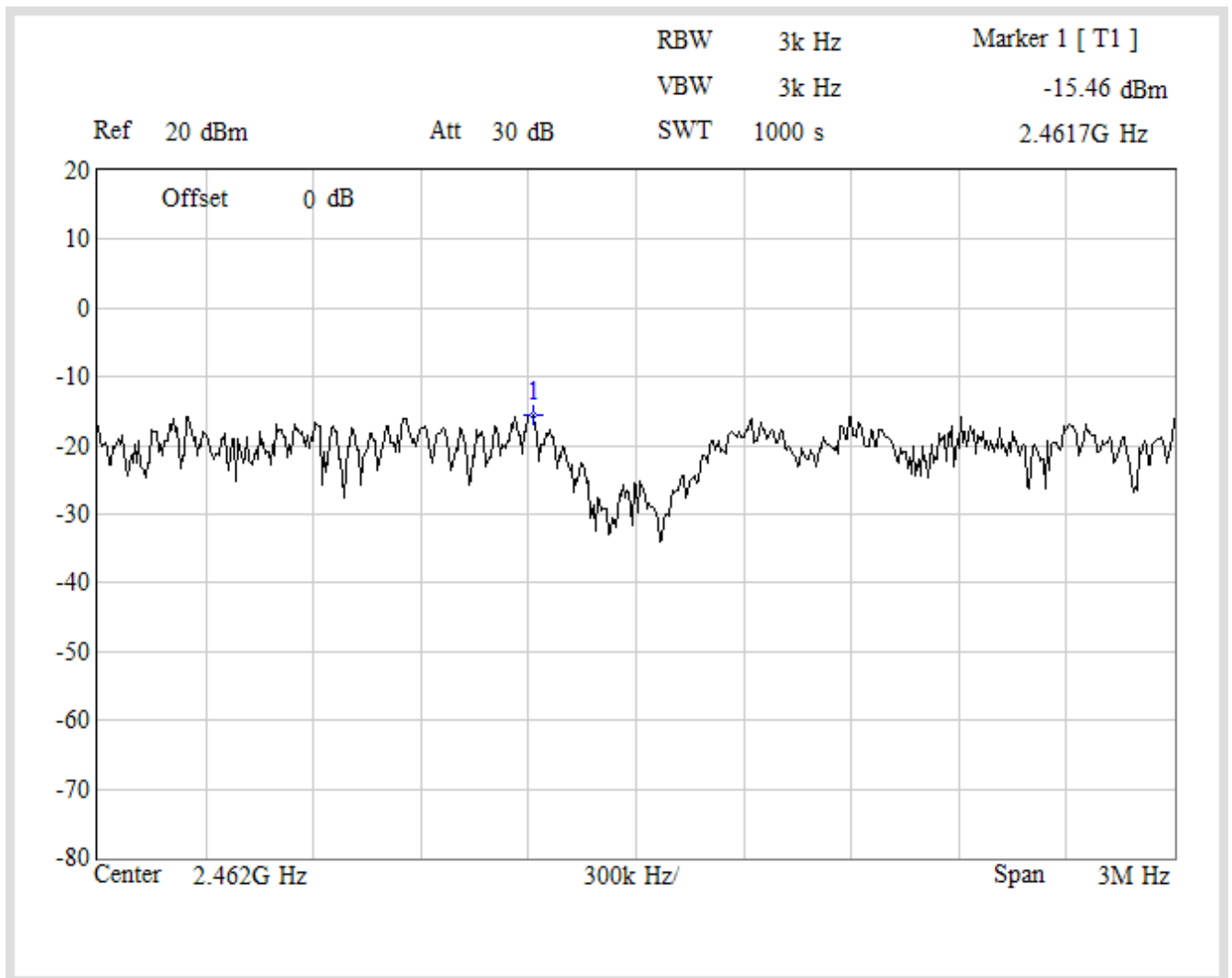

Product	WIRELESS G ADSL2+ MODEM ROUTER		
Test Item	Power Density		
Test Mode	Transmit		
Date of Test	2008/06/30	Test Site	No.1 OATS

IEEE 802.11n (ANT A (20MHz))

Channel No.	Frequency (MHz)	Measure Level (dBm)	Limit (dBm)	Result
1	2412.00	-17.00	<8	Pass
6	2437.00	-17.39	<8	Pass
11	2462.00	-17.19	<8	Pass

Channel 1

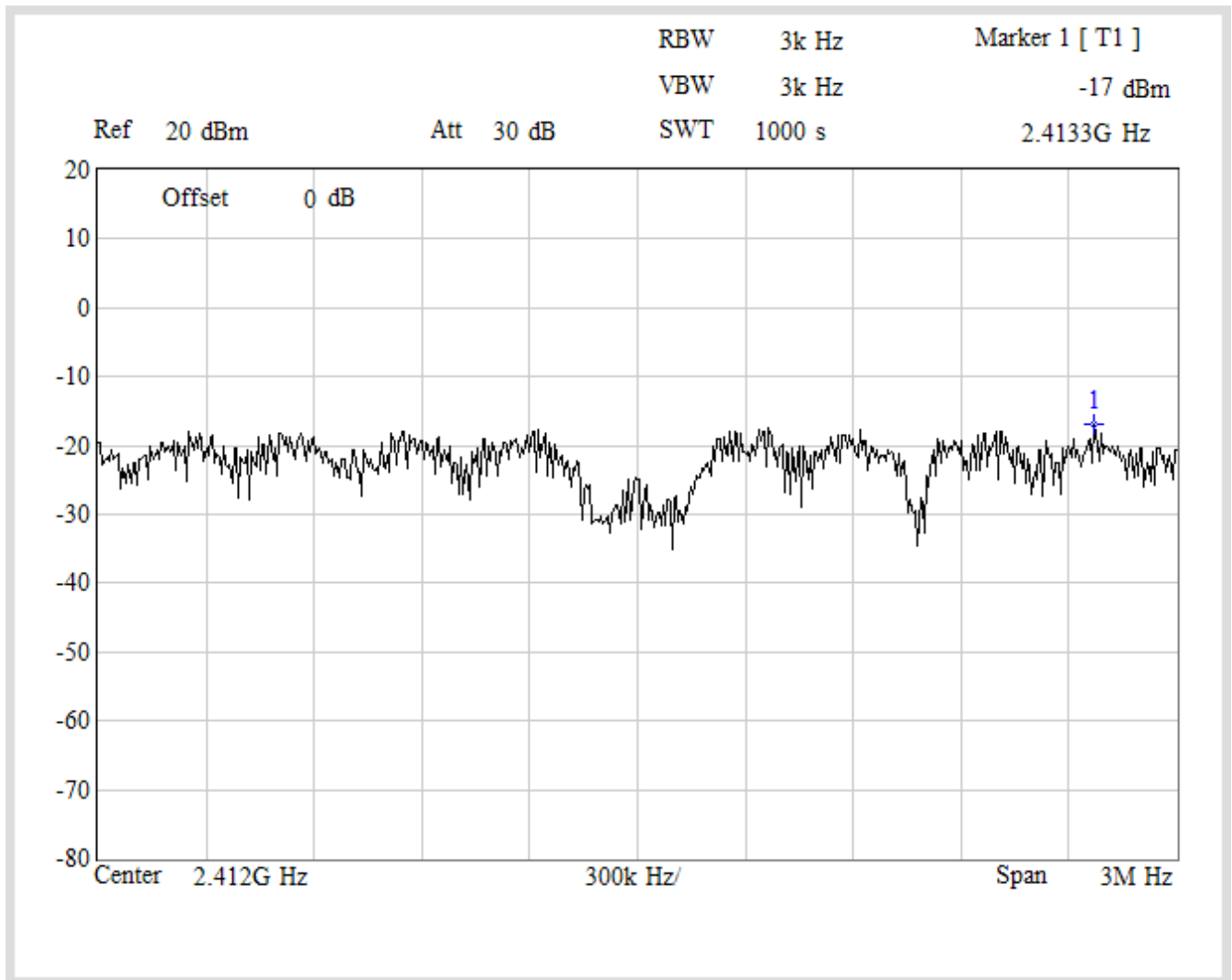

Channel 6

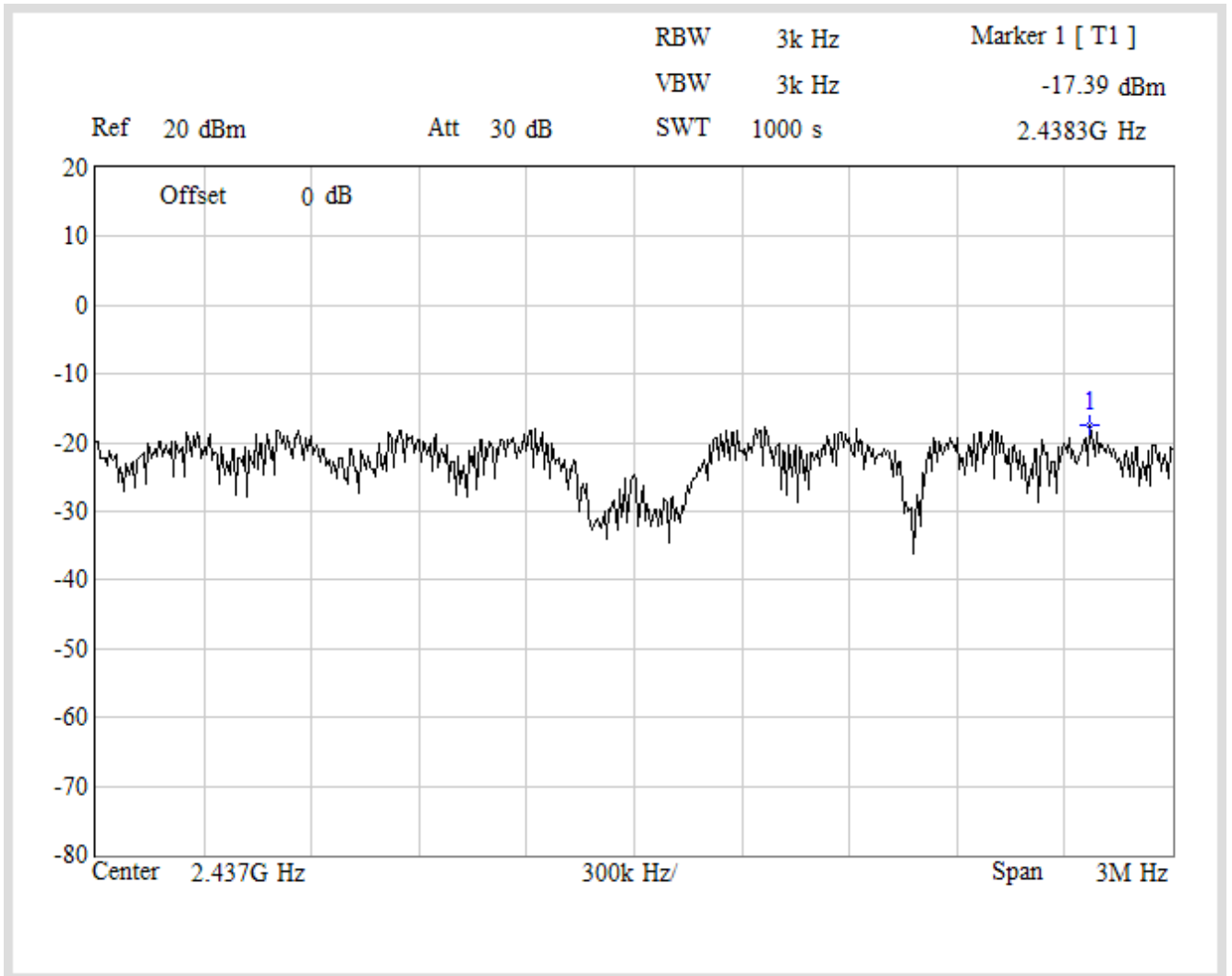

Channel 11

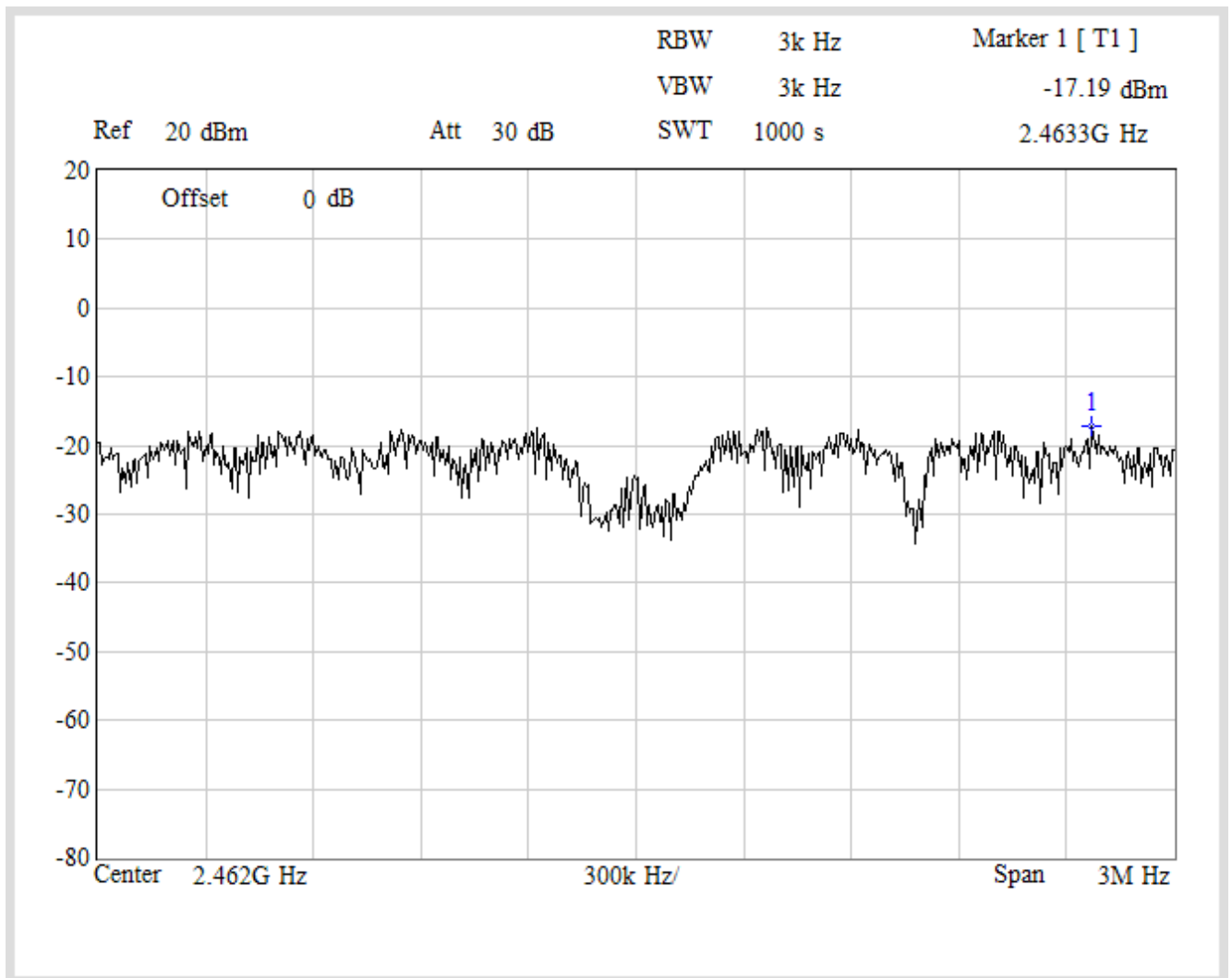

Product	WIRELESS G ADSL2+ MODEM ROUTER		
Test Item	Power Density		
Test Mode	Transmit		
Date of Test	2008/06/30	Test Site	No.1 OATS

IEEE 802.11n (ANT B (20MHz))				
Channel No.	Frequency (MHz)	Measure Level (dBm)	Limit (dBm)	Result
1	2412.00	-16.78	<8	Pass
6	2437.00	-16.73	<8	Pass
11	2462.00	-16.16	<8	Pass

Channel 1

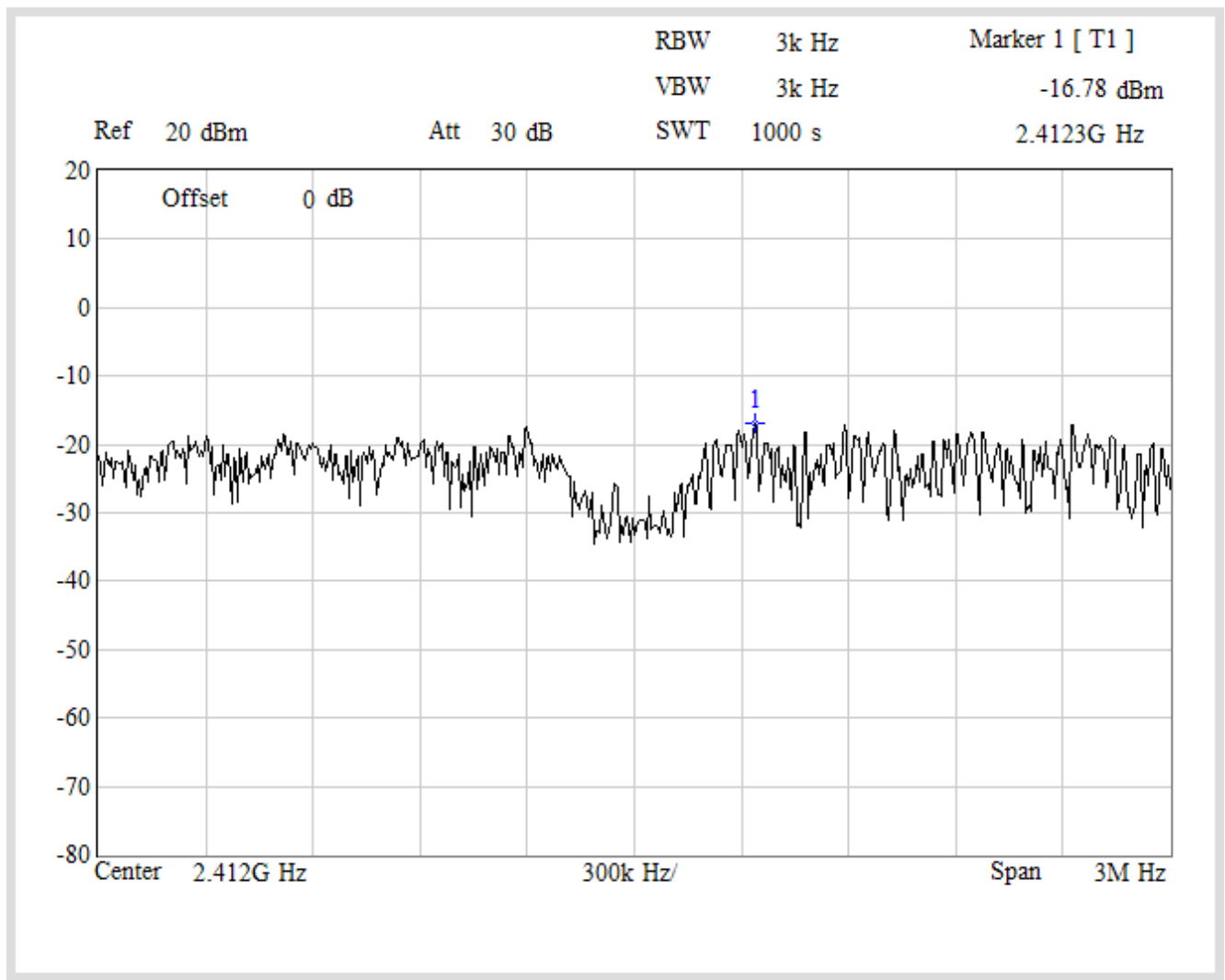

Channel 6

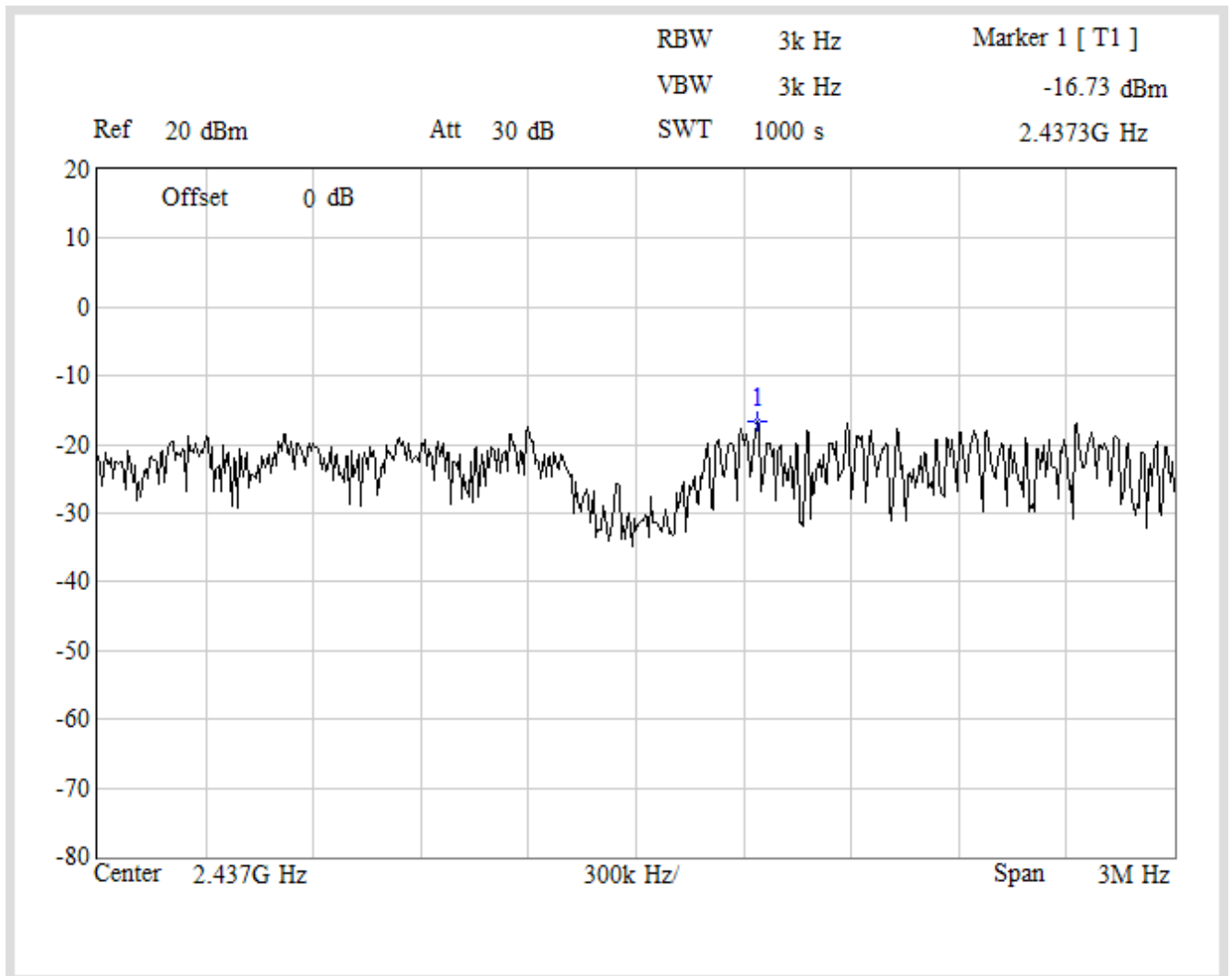

Channel 11

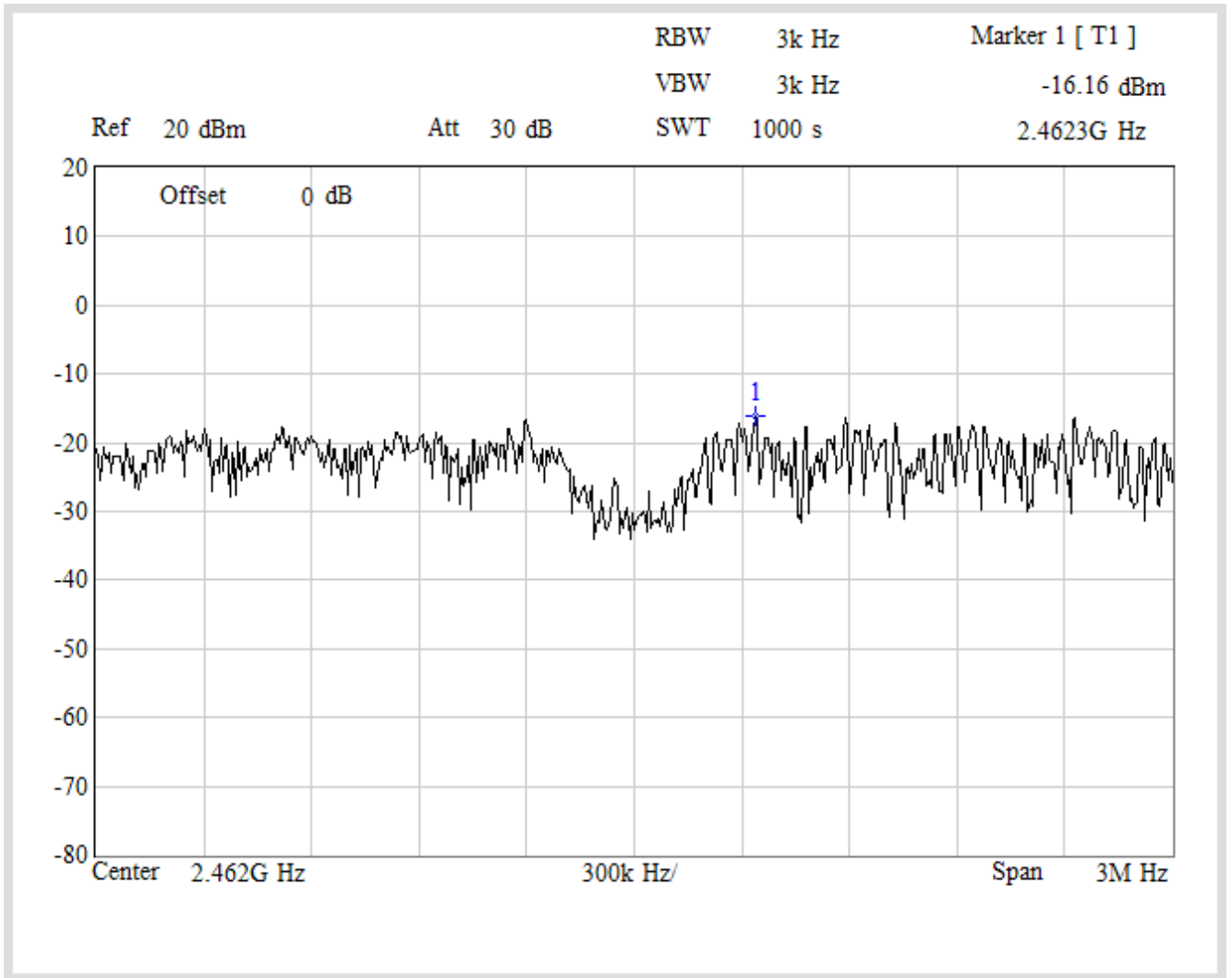

Product	WIRELESS G ADSL2+ MODEM ROUTER		
Test Item	Power Density		
Test Mode	Transmit		
Date of Test	2008/06/30	Test Site	No.1 OATS

IEEE802.11n MCS15 20MHz; ANT: ANT A + ANT B				
Channel No.	Frequency (MHz)	Measure Level(dBm)	Limit(dBm)	Result
1	2412	-13.88	8	Pass
6	2437	-14.04	8	Pass
11	2462	-13.63	8	Pass

Product	WIRELESS G ADSL2+ MODEM ROUTER		
Test Item	Power Density		
Test Mode	Transmit		
Date of Test	2008/06/30	Test Site	No.1 OATS

IEEE 802.11n (ANT A (40MHz))				
Channel No.	Frequency (MHz)	Measure Level (dBm)	Limit (dBm)	Result
3	2422	-18.95	<8	Pass
6	2437	-19.15	<8	Pass
9	2452	-18.81	<8	Pass

Channel 3

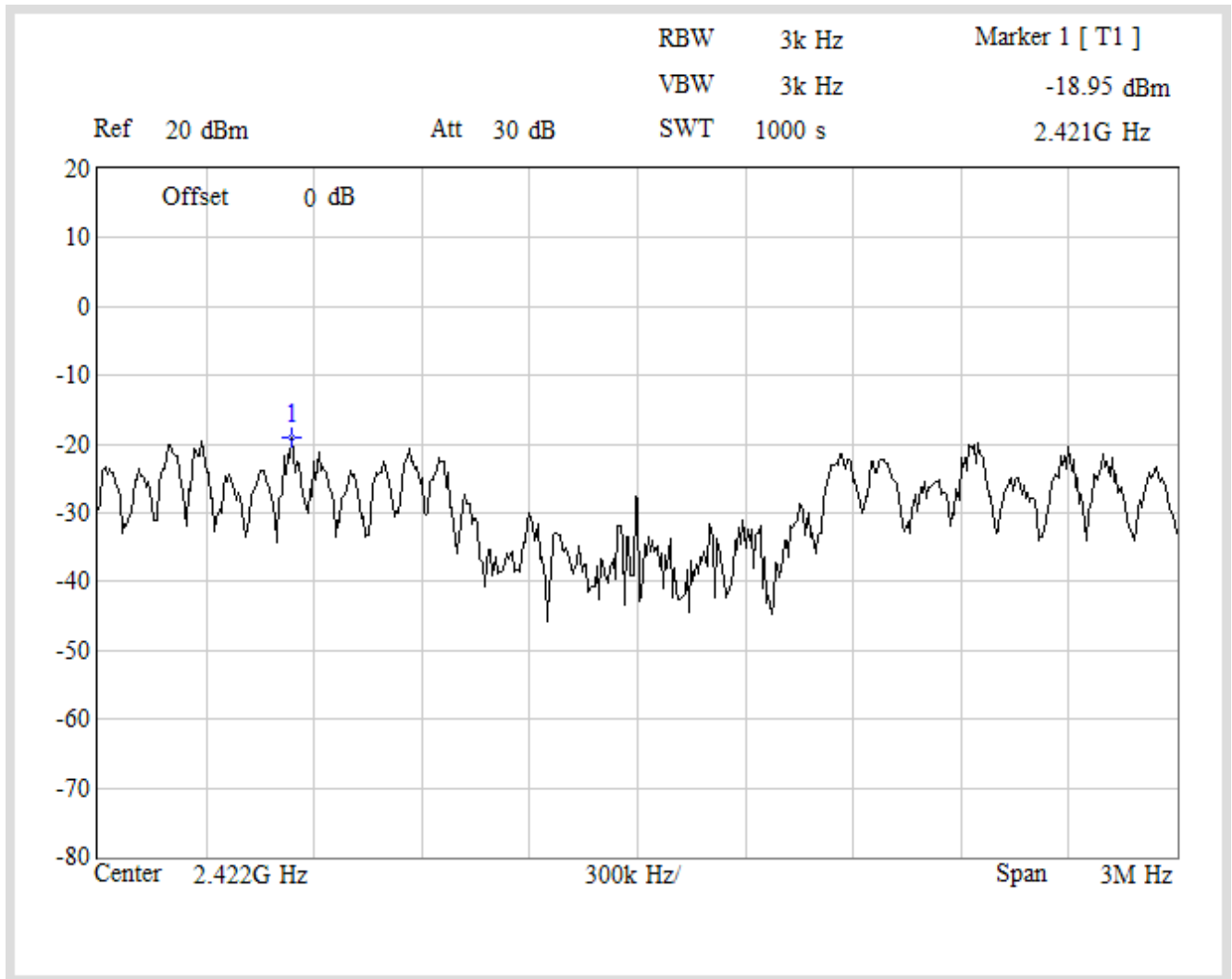

Channel 6

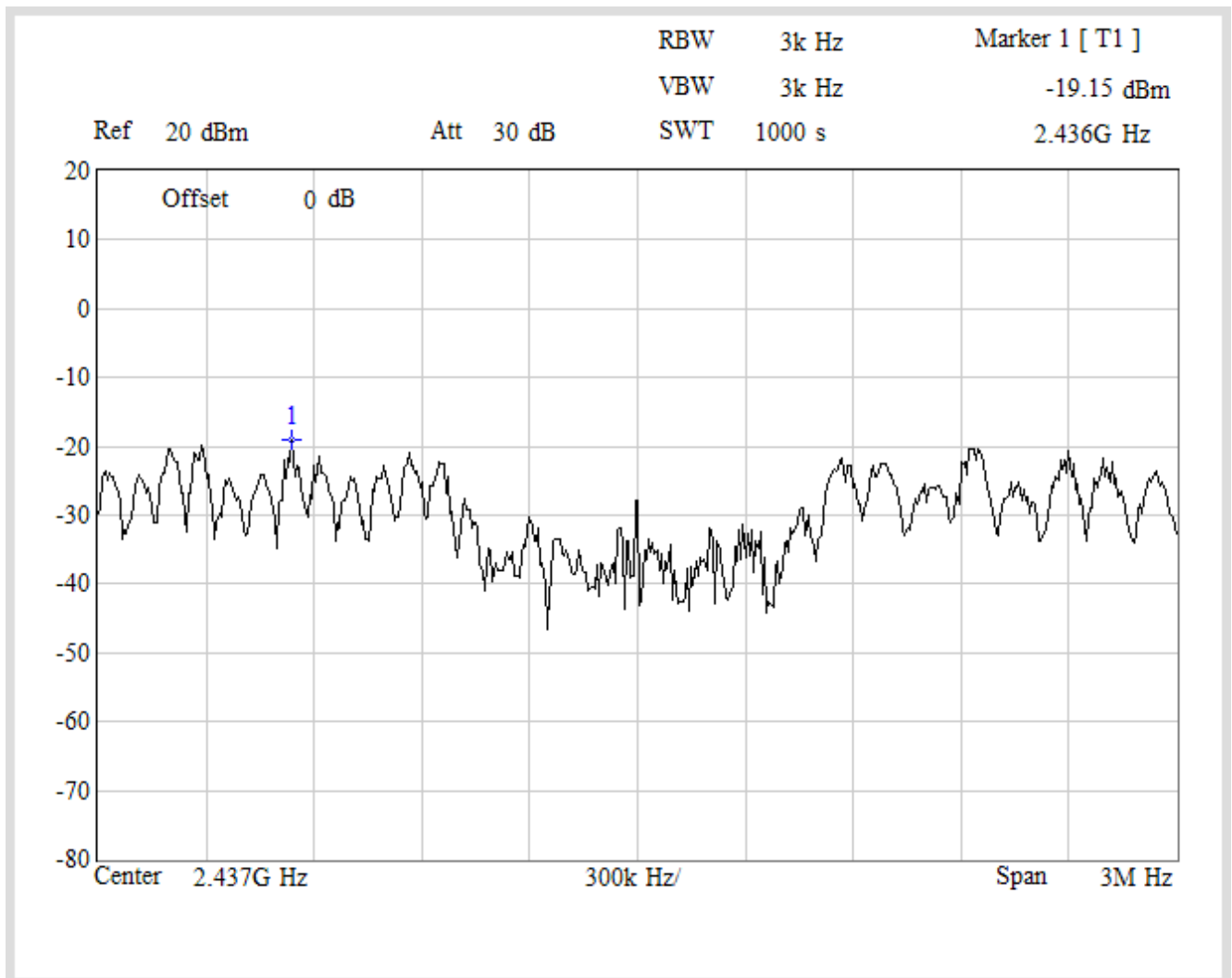

Channel 9

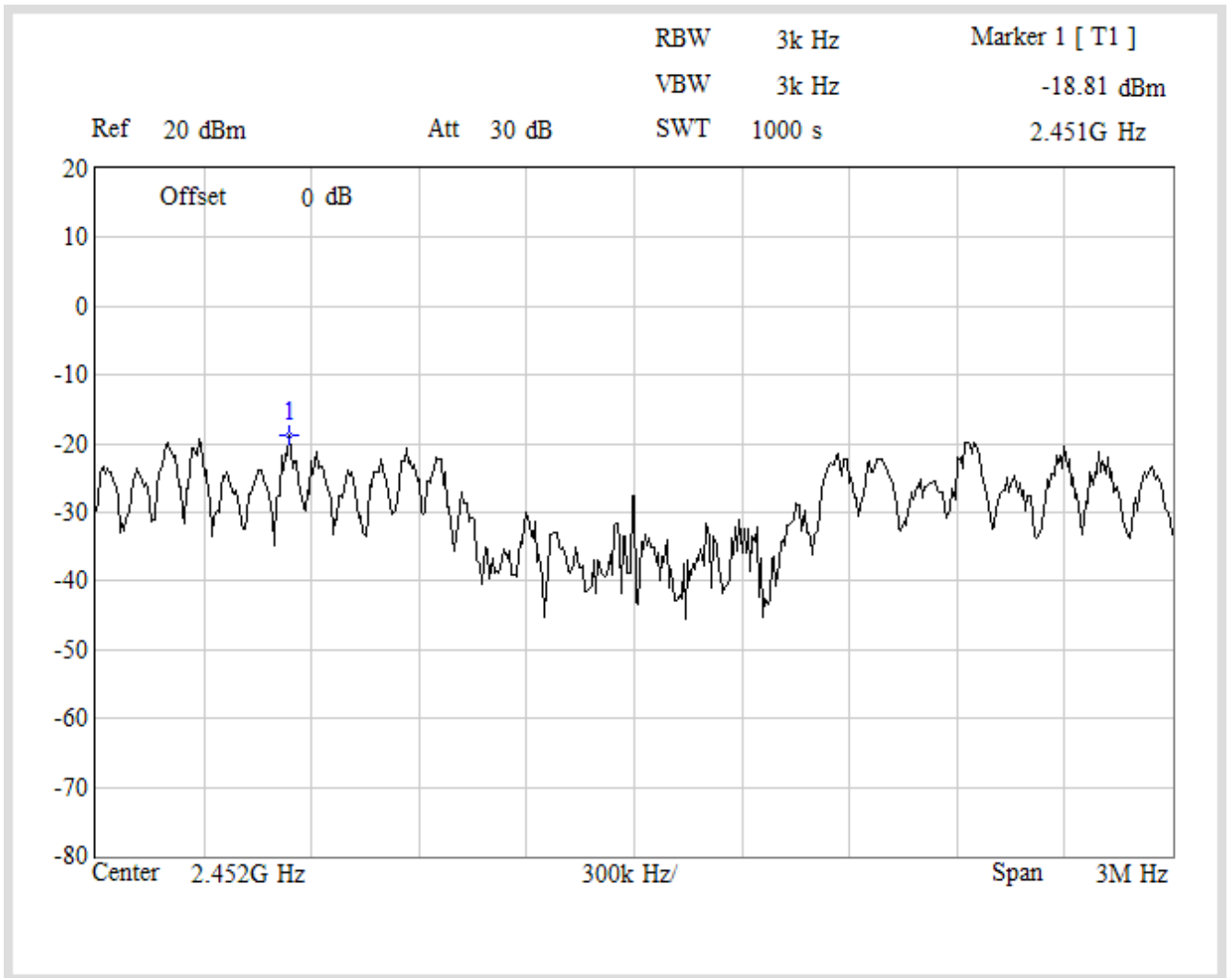

Product	WIRELESS G ADSL2+ MODEM ROUTER		
Test Item	Power Density		
Test Mode	Transmit		
Date of Test	2008/06/30	Test Site	No.1 OATS

IEEE 802.11n (ANT B (40MHz))				
Channel No.	Frequency (MHz)	Measure Level (dBm)	Limit (dBm)	Result
3	2422	-20.36	<8	Pass
6	2437	-20.18	<8	Pass
9	2452	-19.79	<8	Pass

Channel 3

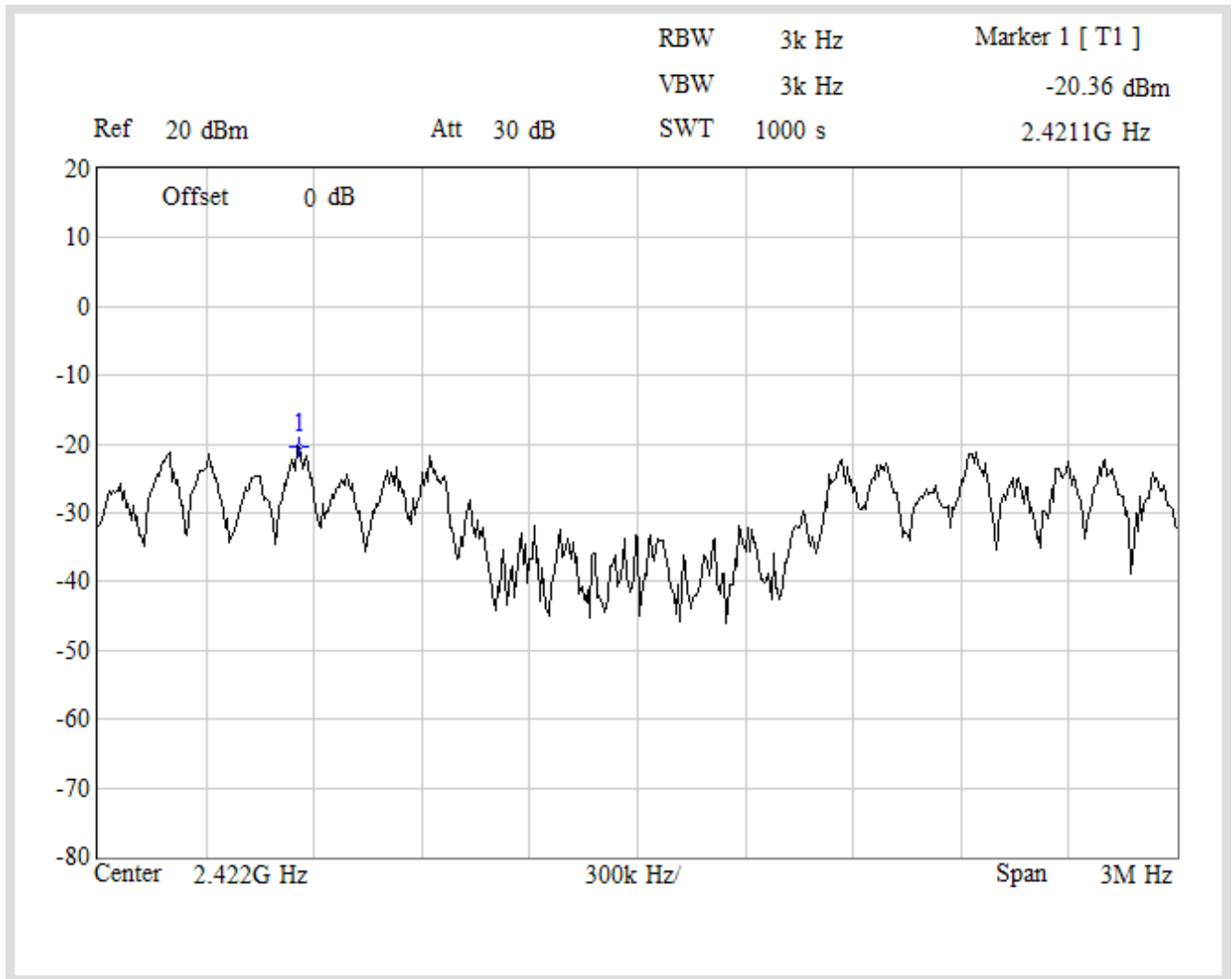

Channel 6

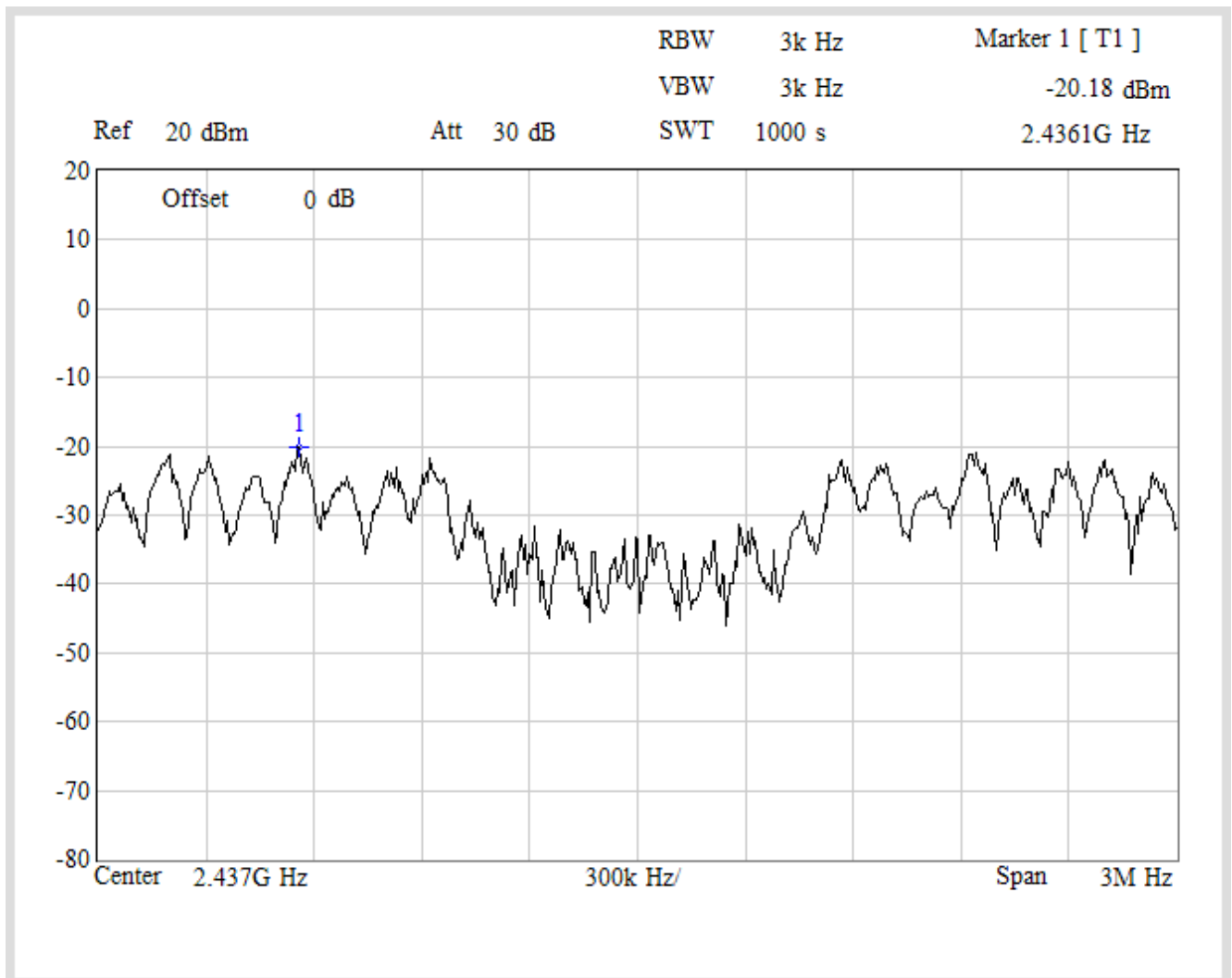

Channel 9

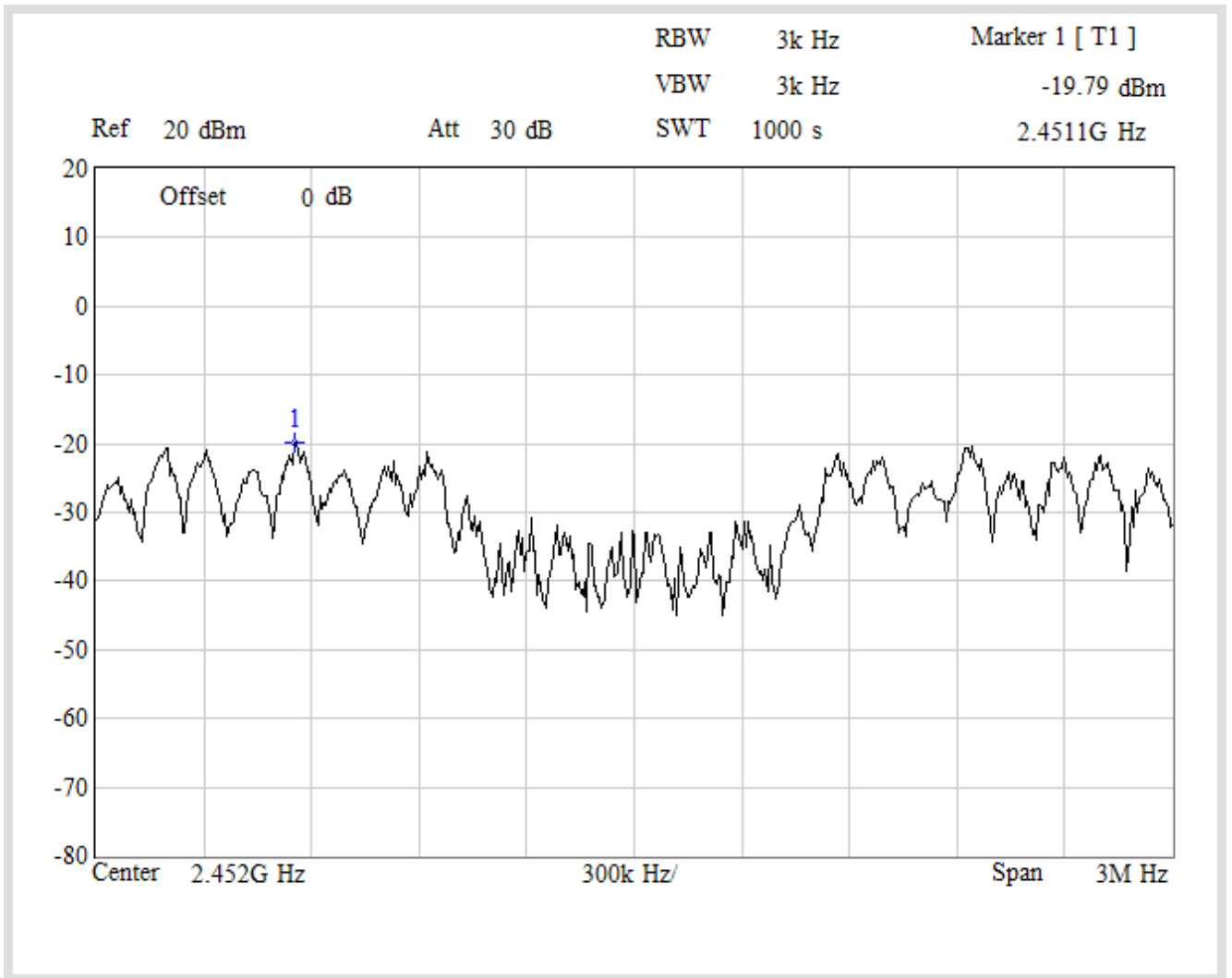

Product	WIRELESS G ADSL2+ MODEM ROUTER		
Test Item	Power Density		
Test Mode	Transmit		
Date of Test	2008/06/30	Test Site	No.1 OATS

IEEE802.11n ;MCS15 40MHz ; ANT: ANT A + ANT B				
Channel No.	Frequency (MHz)	Measure Level(dBm)	Limit(dBm)	Result
3	2422	-16.59	8	Pass
6	2437	-16.62	8	Pass
9	2452	-16.26	8	Pass

10. EMI Reduction Method During Compliance Testing

No modification was made during testing.