

FCC Test Report

Report No.: RFDLK-WTW-P20080511

FCC ID: KA2IS2650APA1

Test Model: DIS-2650AP

Received Date: Aug. 26, 2020

Test Date: Sep. 28, 2020 ~ Sep. 30, 2020

Issued Date: Oct. 30, 2020

Applicant: D-Link Corporation

Address: No. 289, Sinhu 3rd Rd., Neihu District, Taipei City, 114, Taiwan

Issued By: Bureau Veritas Consumer Products Services (H.K.) Ltd., Taoyuan Branch
Lin Kou Laboratories

Lab Address: No. 47-2, 14th Ling, Chia Pau Vil., Lin Kou Dist., New Taipei City, Taiwan

Test Location: No.19, Hwa Ya 2nd Rd., Wen Hwa Vil., Kwei Shan Dist., Taoyuan City
33383, Taiwan

**FCC Registration /
Designation Number:** 788550 / TW0003



This report is for your exclusive use. Any copying or replication of this report to or for any other person or entity, or use of our name or trademark, is permitted only with our prior written permission. This report sets forth our findings solely with respect to the test samples identified herein. The results set forth in this report are not indicative or representative of the quality or characteristics of the lot from which a test sample was taken or any similar or identical product unless specifically and expressly noted. Our report includes all of the tests requested by you and the results thereof based upon the information that you provided to us. You have 60 days from date of issuance of this report to notify us of any material error or omission caused by our negligence, provided, however, that such notice shall be in writing and shall specifically address the issue you wish to raise. A failure to raise such issue within the prescribed time shall constitute your unqualified acceptance of the completeness of this report, the tests conducted and the correctness of the report contents. Unless specific mention, the uncertainty of measurement has been explicitly taken into account to declare the compliance or non-compliance to the specification.

Table of Contents

Release Control Record	4
1 Certificate of Conformity	5
2 Summary of Test Results.....	6
2.1 Measurement Uncertainty.....	6
2.2 Modification Record	6
3 General Information	7
3.1 General Description of EUT	7
3.2 Description of Test Modes.....	8
3.2.1 Test Mode Applicability and Tested Channel Detail.....	9
3.3 Duty Cycle of Test Signal	11
3.4 Description of Support Units	12
3.4.1 Configuration of System under Test	12
3.5 General Description of Applied Standards and References	13
4 Test Types and Results	14
4.1 Radiated Emission and Bandedge Measurement	14
4.1.1 Limits of Radiated Emission and Bandedge Measurement	14
4.1.2 Test Instruments	15
4.1.3 Test Procedures.....	16
4.1.4 Deviation from Test Standard	17
4.1.5 Test Set Up	17
4.1.6 EUT Operating Conditions.....	18
4.1.7 Test Results	19
4.2 Conducted Emission Measurement.....	35
4.2.1 Limits of Conducted Emission Measurement	35
4.2.2 Test Instruments	35
4.2.3 Test Procedures.....	36
4.2.4 Deviation from Test Standard	36
4.2.5 Test Setup.....	36
4.2.6 EUT Operating Conditions.....	36
4.2.7 Test Results	37
4.3 6 dB Bandwidth Measurement.....	41
4.3.1 Limits of 6 dB Bandwidth Measurement.....	41
4.3.2 Test Setup.....	41
4.3.3 Test Instruments	41
4.3.4 Test Procedure	41
4.3.5 Deviation from Test Standard	41
4.3.6 EUT Operating Conditions.....	41
4.3.7 Test Results	42
4.4 Occupied Bandwidth Measurement.....	44
4.4.1 Test Setup.....	44
4.4.2 Test Instruments	44
4.4.3 Test Procedure	44
4.4.4 Deviation from Test Standard	44
4.4.5 EUT Operating Conditions.....	44
4.4.6 Test Results	45
4.5 Conducted Output Power Measurement	47
4.5.1 Limits of Conducted Output Power Measurement.....	47
4.5.2 Test Setup.....	47
4.5.3 Test Instruments	47
4.5.4 Test Procedures.....	47
4.5.5 Deviation from Test Standard	47
4.5.6 EUT Operating Conditions.....	47
4.5.7 Test Results	48

4.6	Power Spectral Density Measurement	50
4.6.1	Limits of Power Spectral Density Measurement.....	50
4.6.2	Test Setup.....	50
4.6.3	Test Instruments	50
4.6.4	Test Procedure	51
4.6.5	Deviation from Test Standard	51
4.6.6	EUT Operating Condition	51
4.6.7	Test Results	52
4.7	Conducted Out of Band Emission Measurement	55
4.7.1	Limits of Conducted Out of Band Emission Measurement.....	55
4.7.2	Test Setup.....	55
4.7.3	Test Instruments	55
4.7.4	Test Procedure	55
4.7.5	Deviation from Test Standard	55
4.7.6	EUT Operating Condition	55
4.7.7	Test Results	56
5	Pictures of Test Arrangements.....	65
	Annex A- Band-edge measurement	66
	Appendix – Information of the Testing Laboratories	74



Release Control Record

Issue No.	Description	Date Issued
RFDLK-WTW-P20080511	Original Release	Oct. 30, 2020

1 Certificate of Conformity

Product: Wireless AC1200 Wave 2 Industrial indoor access point

Brand: D-Link

Test Model: DIS-2650AP

Sample Status: Engineering Sample

Applicant: D-Link Corporation

Test Date: Sep. 28, 2020 ~ Sep. 30, 2020

Standards: 47 CFR FCC Part 15, Subpart C (Section 15.247)
ANSI C63.10:2013

The above equipment has been tested by **Bureau Veritas Consumer Products Services (H.K.) Ltd., Taoyuan Branch**, and found compliance with the requirement of the above standards. The test record, data evaluation & Equipment Under Test (EUT) configurations represented herein are true and accurate accounts of the measurements of the sample's RF characteristics under the conditions specified in this report.

Prepared by : Shelly Hsueh, **Date:** Oct. 30, 2020
Shelly Hsueh / Specialist

Approved by : Dylan Chiou, **Date:** Oct. 30, 2020
Dylan Chiou / Senior Project Engineer

2 Summary of Test Results

47 CFR FCC Part 15, Subpart C (Section 15.247)			
FCC Clause	Test Item	Result	Remarks
15.207	AC Power Conducted Emission	Pass	Meet the requirement of limit. Minimum passing margin is -2.18 dB at 0.394 MHz.
15.205 / 15.209 / 15.247(d)	Radiated Emissions and Band Edge Measurement	Pass	Meet the requirement of limit. Minimum passing margin is -0.32 dB at 2484.23 MHz.
15.247(d)	Antenna Port Emission	Pass	Meet the requirement of limit.
15.247(a)(2)	6 dB Bandwidth	Pass	Meet the requirement of limit.
---	Occupied Bandwidth Measurement	Pass	Reference only
15.247(b)	Conducted power	Pass	Meet the requirement of limit.
15.247(e)	Power Spectral Density	Pass	Meet the requirement of limit.
15.203	Antenna Requirement	Pass	Antenna connector is SMA Male Reverse connector not a standard connector.

Note

- For 2.4G band compliance with rule 15.247(d) of the band-edge items, the test plots were recorded in Annex A. Test Procedures refer to report 4.1.3.
- Determining compliance based on the results of the compliance measurement, not taking into account measurement instrumentation uncertainty.

2.1 Measurement Uncertainty

Where relevant, the following measurement uncertainty levels have been estimated for tests performed on the EUT as specified in CISPR 16-4-2:

Measurement	Frequency	Expanded Uncertainty (k=2) (±)
Conducted Emissions at mains ports	150 kHz ~ 30 MHz	2.79 dB
Radiated Emissions up to 1 GHz	9 kHz ~ 30 MHz	3.04 dB
	30 MHz ~ 200 MHz	2.93 dB
	200 MHz ~ 1000 MHz	2.95 dB
Radiated Emissions above 1 GHz	1 GHz ~ 18 GHz	2.26 dB
	18 GHz ~ 40 GHz	1.94 dB

2.2 Modification Record

There were no modifications required for compliance.

3 General Information

3.1 General Description of EUT

Product	Wireless AC1200 Wave 2 Industrial indoor access point
Brand	D-Link
Test Model	DIS-2650AP
Status of EUT	Engineering Sample
Power Supply Rating	48 Vdc (from POE) 12 Vdc (from DC power source)
Modulation Type	CCK, DQPSK, DBPSK for DSSS 256QAM, 64QAM, 16QAM, QPSK, BPSK for OFDM
Modulation Technology	DSSS, OFDM
Transfer Rate	802.11b: 11.0 / 5.5 / 2.0 / 1.0 Mbps 802.11g: 54.0 / 48.0 / 36.0 / 24.0 / 18.0 / 12.0 / 9.0 / 6.0 Mbps 802.11n: up to 300Mbps
Operating Frequency	2412 ~ 2462 MHz
Number of Channel	11 for 802.11b, 802.11g, 802.11n (HT20) 7 for 802.11n (HT40)
Output Power	CDD Mode: 93.898 mW Beamforming Mode: 93.688 mW
Antenna Type	Dipole antenna with 4.11 dBi gain
Antenna Connector	SMA Male Reverse
Accessory Device	N/A
Data Cable Supplied	N/A

Note:

1. The EUT incorporates a MIMO function. Physically, the EUT provides 2 completed transmitters and 2 receivers.

Modulation Mode	CDD Mode	Beamforming Mode
802.11b	Support	Not Support
802.11g	Support	Not Support
802.11n (HT20)	Support	Support
802.11n (HT40)	Support	Support

* The bandwidth and modulation are similar for HT20/HT40 on 802.11n mode and VHT20/VHT40 on 802.11n mode. Therefore the investigated worst case is the representative mode in test report. (Final test mode refer section 3.2.1)

2. The above Antenna information is declared by manufacturer and for more detailed features description, please refer to the manufacturer's specifications, the laboratory shall not be held responsible.
3. The above EUT information is declared by manufacturer and for more detailed features description, please refers to the manufacturer's specifications or user's manual.

3.2 Description of Test Modes

11 channels are provided for 802.11b, 802.11g and 802.11n (HT20):

Channel	Frequency (MHz)	Channel	Frequency (MHz)
1	2412	7	2442
2	2417	8	2447
3	2422	9	2452
4	2427	10	2457
5	2432	11	2462
6	2437		

7 channels are provided for 802.11n (HT40):

Channel	Frequency (MHz)	Channel	Frequency (MHz)
3	2422	7	2442
4	2427	8	2447
5	2432	9	2452
6	2437		

3.2.1 Test Mode Applicability and Tested Channel Detail

EUT Configure Mode	Applicable To				Description
	RE≥1G	RE<1G	PLC	APCM	
A	√	√	√	√	Power from POE
B	-	√	√	-	Power from DC Source

Where **RE≥1G**: Radiated Emission above 1 GHz **RE<1G**: Radiated Emission below 1 GHz
PLC: Power Line Conducted Emission **APCM**: Antenna Port Conducted Measurement

NOTE: The EUT had been pre-tested on the positioned of each 3 axis. The worst case was found when positioned on **Z-plane**
NOTE: For radiated emission (below 1GHz) and power line conducted emission test items, the worst maximum power was selected..
NOTE: "-" means no effect.

Radiated Emission Test (Above 1 GHz):

- Pre-Scan has been conducted to determine the worst-case mode from all possible combinations between available modulations, data rates and antenna ports (if EUT with antenna diversity architecture).
- Following channel(s) was (were) selected for the final test as listed below.

EUT Configure Mode	Mode	Available Channel	Tested Channel	Modulation Technology	Modulation Type	Data Rate (Mbps)
A	802.11b	1 to 11	1, 6, 11	DSSS	DBPSK	1.0
A	802.11g	1 to 11	1, 6, 11	OFDM	BPSK	6.0
A	802.11n (HT20)	1 to 11	1, 6, 11	OFDM	BPSK	6.5
A	802.11n (HT40)	3 to 9	3, 6, 9	OFDM	BPSK	13.5

Radiated Emission Test (Below 1 GHz):

- Pre-Scan has been conducted to determine the worst-case mode from all possible combinations between available modulations, data rates and antenna ports (if EUT with antenna diversity architecture).
- Following channel(s) was (were) selected for the final test as listed below.

EUT Configure Mode	Mode	Available Channel	Tested Channel	Modulation Technology	Modulation Type	Data Rate (Mbps)
A,B	802.11b	1 to 11	6	OFDM	BPSK	1.0

Power Line Conducted Emission Test:

- Pre-Scan has been conducted to determine the worst-case mode from all possible combinations between available modulations, data rates and antenna ports (if EUT with antenna diversity architecture).
- Following channel(s) was (were) selected for the final test as listed below.

EUT Configure Mode	Mode	Available Channel	Tested Channel	Modulation Technology	Modulation Type	Data Rate (Mbps)
A,B	802.11b	1 to 11	6	OFDM	BPSK	1.0

Bandedge Measurement:

- Pre-Scan has been conducted to determine the worst-case mode from all possible combinations between available modulations, data rates and antenna ports (if EUT with antenna diversity architecture).
- Following channel(s) was (were) selected for the final test as listed below.

EUT Configure Mode	Mode	Available Channel	Tested Channel	Modulation Technology	Modulation Type	Data Rate (Mbps)
A	802.11b	1 to 11	1, 11	DSSS	DBPSK	1.0
A	802.11g	1 to 11	1, 11	OFDM	BPSK	6.0
A	802.11n (HT20)	1 to 11	1, 11	OFDM	BPSK	6.5
A	802.11n (HT40)	3 to 9	3, 9	OFDM	BPSK	13.5

Antenna Port Conducted Measurement:

- This item includes all test value of each mode, but only includes spectrum plot of worst value of each mode.
- Pre-Scan has been conducted to determine the worst-case mode from all possible combinations between available modulations, data rates and antenna ports (if EUT with antenna diversity architecture).
- Following channel(s) was (were) selected for the final test as listed below.

EUT Configure Mode	Mode	Available Channel	Tested Channel	Modulation Technology	Modulation Type	Data Rate (Mbps)
A	802.11b	1 to 11	1, 6, 11	DSSS	DBPSK	1.0
A	802.11g	1 to 11	1, 6, 11	OFDM	BPSK	6.0
A	802.11n (HT20)	1 to 11	1, 6, 11	OFDM	BPSK	6.5
A	802.11n (HT40)	3 to 9	3, 6, 9	OFDM	BPSK	13.5

Test Condition:

Applicable To	Environmental Conditions	Input Power	Tested by
RE \geq 1G	25 deg. C, 65 % RH	120 Vac, 60 Hz	Cyril Chen
RE<1G	25 deg. C, 65 % RH	120 Vac, 60 Hz	Tim Chen
PLC	25 deg. C, 65 % RH	120 Vac, 60 Hz	Cyril Chen
APCM	25 deg. C, 65 % RH	48 Vdc	Ivan Tseng

3.3 Duty Cycle of Test Signal

Duty cycle of test signal is $\geq 98\%$, duty factor is not required.

Duty cycle of test signal is $< 98\%$, duty factor shall be considered.

802.11b: Duty cycle = $12.162/12.25 = 0.993$

802.11g: Duty cycle = $2.017/2.082 = 0.969$, Duty factor = $10 * \log(1/0.969) = 0.14$

802.11n (HT20): Duty cycle = $1.885/1.945 = 0.969$, Duty factor = $10 * \log(1/0.969) = 0.14$

802.11n (HT40): Duty cycle = $0.925/0.965 = 0.959$, Duty factor = $10 * \log(1/0.959) = 0.18$

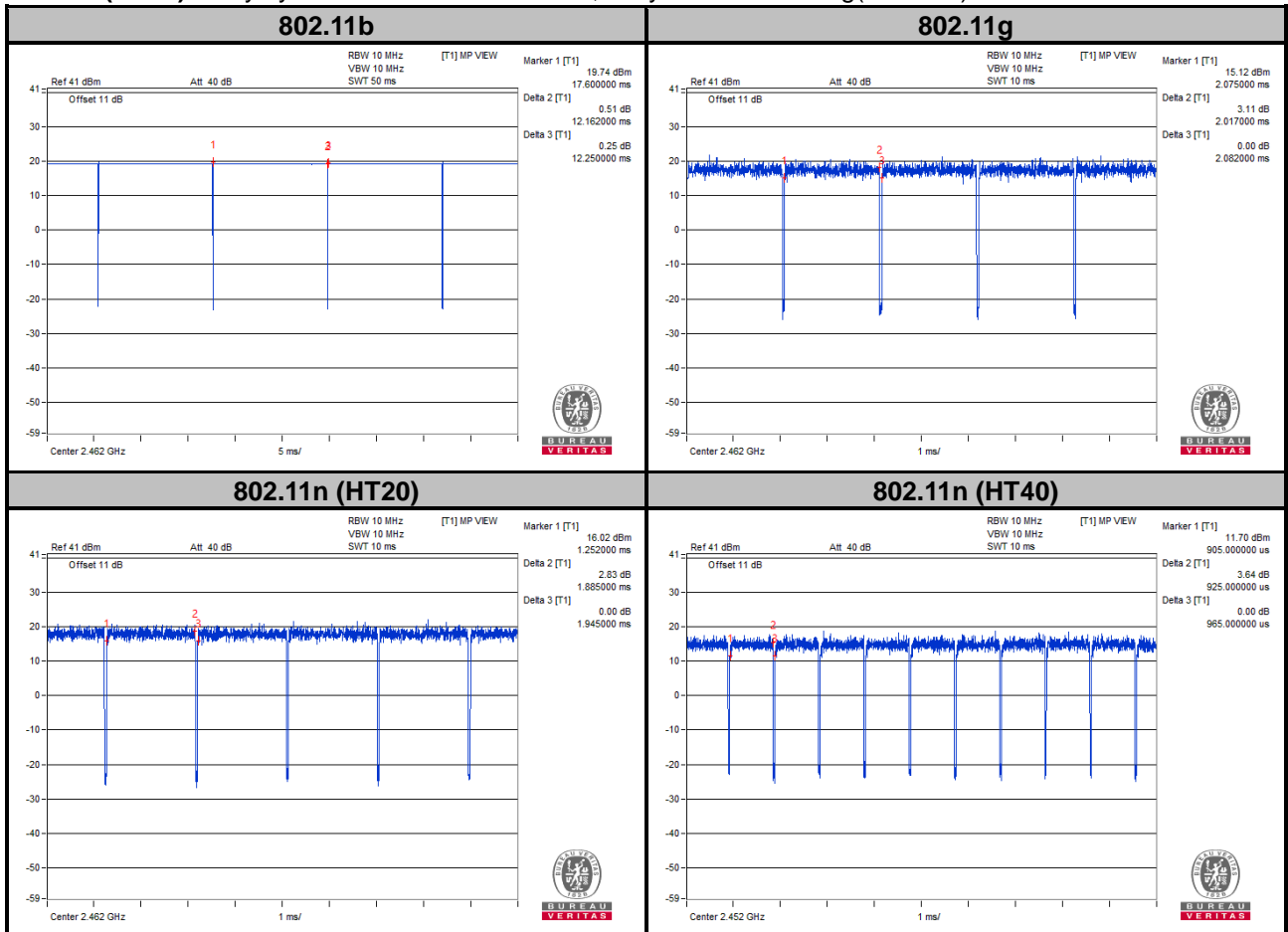

3.4 Description of Support Units

The EUT has been tested as an independent unit together with other necessary accessories or support units. The following support units or accessories were used to form a representative test configuration during the tests.

No.	Product	Brand	Model No.	Serial No.	FCC ID
1.	POE	PLANET	POE-171A-95	N/A	N/A
2.	DC Power Supply	GAIRAUGUS	33010D	807748	N/A

Note:

1. All power cords of the above support units are non-shielded (1.8m).

3.4.1 Configuration of System under Test

Mode A

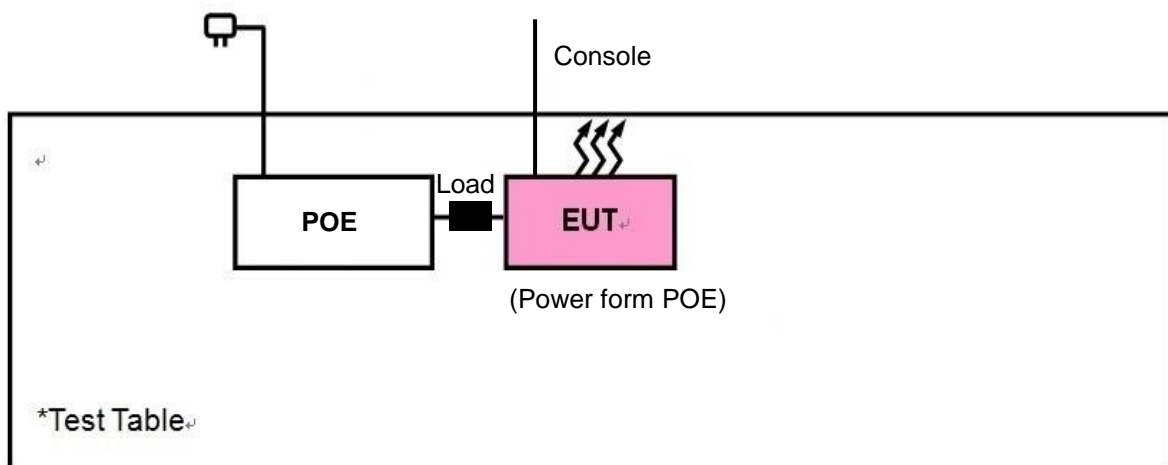

Mode B

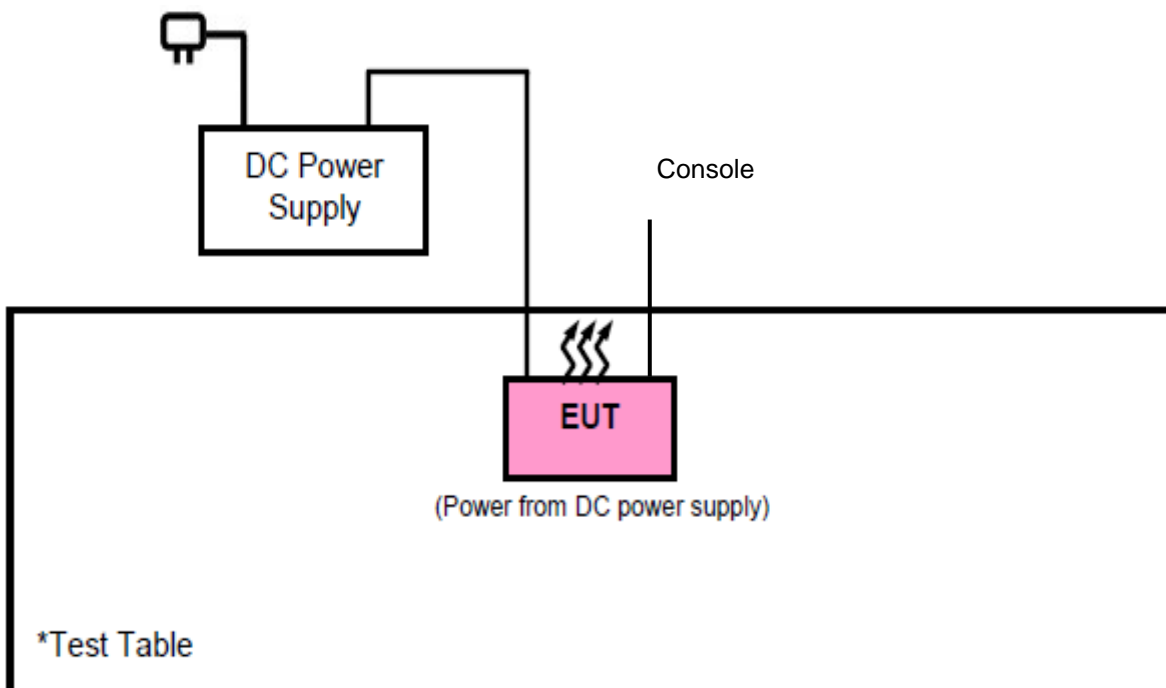

3.5 General Description of Applied Standards and References

The EUT is a RF Product. According to the specifications of the manufacturer, it must comply with the requirements of the following standards and references:

Test Standard:

FCC Part 15, Subpart C (15.247)

ANSI C63.10-2013

All test items have been performed and recorded as per the above standards.

References Test Guidance:

KDB 558074 D01 Meas Guidance v05r02

KDB 662911 D01 Multiple Transmitter Output v02r01

All test items have been performed as a reference to the above KDB test guidance.

4 Test Types and Results

4.1 Radiated Emission and Bandedge Measurement

4.1.1 Limits of Radiated Emission and Bandedge Measurement

Radiated emissions which fall in the restricted bands must comply with the radiated emission limits specified as below table. Other emissions shall be at least 30 dB below the highest level of the desired power:

Frequencies (MHz)	Field Strength (microvolts/meter)	Measurement Distance (meters)
0.009 ~ 0.490	2400/F (kHz)	300
0.490 ~ 1.705	24000/F (kHz)	30
1.705 ~ 30.0	30	30
30 ~ 88	100	3
88 ~ 216	150	3
216 ~ 960	200	3
Above 960	500	3

NOTE:

1. The lower limit shall apply at the transition frequencies.
2. Emission level (dBuV/m) = 20 log Emission level (uV/m).
3. For frequencies above 1000 MHz, the field strength limits are based on average detector, however, the peak field strength of any emission shall not exceed the maximum permitted average limits, specified above by more than 20 dB under any condition of modulation.

4.1.2 Test Instruments

Description & Manufacturer	Model No.	Serial No.	Date of Calibration	Due Date of Calibration
Test Receiver Agilent	N9038A	MY51210203	Mar. 18, 2020	Mar. 17, 2021
Spectrum Analyzer Agilent	N9010A	MY52220314	Dec. 12, 2019	Dec. 11, 2020
Spectrum Analyzer ROHDE & SCHWARZ	FSU43	101261	Apr. 16, 2020	Apr. 15, 2021
HORN Antenna SCHWARZBECK	BBHA 9120D	9120D-969	Nov. 24, 2019	Nov. 23, 2020
BILOG Antenna SCHWARZBECK	VULB 9168	9168-472	Nov. 08, 2019	Nov. 07, 2020
Fixed Attenuator WORKEN	MDCS18N-10	MDCS18N-10-01	Apr. 14, 2020	Apr. 13, 2021
Loop Antenna	EM-6879	269	Sep. 17, 2020	Sep. 16, 2021
Preamplifier EMCI	EMC001340	980201	Oct. 21, 2019	Oct. 20, 2020
Preamplifier EMCI	EMC 330H	980112	Oct. 07, 2019	Oct. 06, 2020
Power Meter Anritsu	ML2495A	1012010	Sep. 01, 2020	Aug. 31, 2021
Power Sensor Anritsu	MA2411B	1315050	Sep. 01, 2020	Aug. 31, 2021
RF Coaxial Cable EMCI	EMC104-SM-SM-8000	171005	Oct. 07, 2019	Oct. 06, 2020
RF Coaxial Cable HUBER+SUHNNER	SUCOFLEX 104	EMC104-SM-SM-1000(140807)	Oct. 07, 2019	Oct. 06, 2020
RF Coaxial Cable Worken	8D-FB	Cable-Ch10-01	Oct. 07, 2019	Oct. 06, 2020
Boresight Antenna Fixture	FBA-01	FBA-SIP01	NA	NA
Software BV ADT	E3 6.120103	NA	NA	NA
Antenna Tower MF	MFA-440H	NA	NA	NA
Turn Table MF	MFT-201SS	NA	NA	NA
Antenna Tower & Turn Table Controller MF	MF-7802	NA	NA	NA

- NOTE:** 1. The calibration interval of the above test instruments is 12 months and the calibrations are traceable to NML/ROC and NIST/USA.
2. The test was performed in HwaYa Chamber 10.

4.1.3 Test Procedures

For Radiated Emission below 30 MHz

- a. The EUT was placed on the top of a rotating table 0.8 meters above the ground at a 3 meter chamber room. The table was rotated 360 degrees to determine the position of the highest radiation.
- b. The EUT was set 3 meters away from the interference-receiving antenna, which was mounted on the top of a variable-height antenna tower.
- c. Parallel, perpendicular, and ground-parallel orientations of the antenna are set to make the measurement.
- d. For each suspected emission, the EUT was arranged to its worst case and the rotatable table was turned from 0 degrees to 360 degrees to find the maximum reading.
- e. The test-receiver system was set to Quasi-Peak Detect Function and Specified Bandwidth with Maximum Hold Mode.

Note:

1. The resolution bandwidth and video bandwidth of test receiver/spectrum analyzer is 9 kHz at frequency below 30 MHz.

For Radiated Emission above 30 MHz

- a. The EUT was placed on the top of a rotating table 0.8 meters (for 30 MHz ~ 1 GHz) / 1.5 meters (for above 1 GHz) above the ground at 3 meter chamber room for test. The table was rotated 360 degrees to determine the position of the highest radiation.
- b. The EUT was set 3 meters away from the interference-receiving antenna, which was mounted on the top of a variable-height antenna tower.
- c. The height of antenna is varied from one meter to four meters above the ground to determine the maximum value of the field strength. Both horizontal and vertical polarizations of the antenna are set to make the measurement.
- d. For each suspected emission, the EUT was arranged to its worst case and then the antenna was tuned to heights from 1 meter to 4 meters and the rotatable table was turned from 0 degrees to 360 degrees to find the maximum reading.
- e. The test-receiver system was set to quasi-peak detect function and specified bandwidth with maximum hold mode when the test frequency is below 1 GHz.
- f. The test-receiver system was set to peak and average detected function and specified bandwidth with maximum hold mode when the test frequency is above 1 GHz. If the peak reading value also meets average limit, measurement with the average detector is unnecessary.

Note:

1. The resolution bandwidth and video bandwidth of test receiver/spectrum analyzer is 120 kHz for Quasi-peak detection (QP) or Peak detection (PK) at frequency below 1 GHz.
2. The resolution bandwidth of test receiver/spectrum analyzer is 1 MHz and the video bandwidth is 3 MHz for Peak detection (PK) at frequency above 1 GHz.
3. The resolution bandwidth of test receiver/spectrum analyzer is 1 MHz and the video bandwidth is $\geq 1/T$ (Duty cycle < 98 %) or 10 Hz (Duty cycle ≥ 98 %) for Average detection (AV) at frequency above 1 GHz.
(11b: RBW = 1 MHz, VBW = 10 Hz ; 11g: RBW = 1 MHz, VBW = 1 kHz ;
11n (HT20): RBW = 1 MHz, VBW = 1 kHz ; 11n (HT40): RBW = 1 MHz, VBW = 2 kHz)
4. All modes of operation were investigated and the worst-case emissions are reported.

4.1.4 Deviation from Test Standard

No deviation.

4.1.5 Test Set Up

<Radiated Emission below 30 MHz>

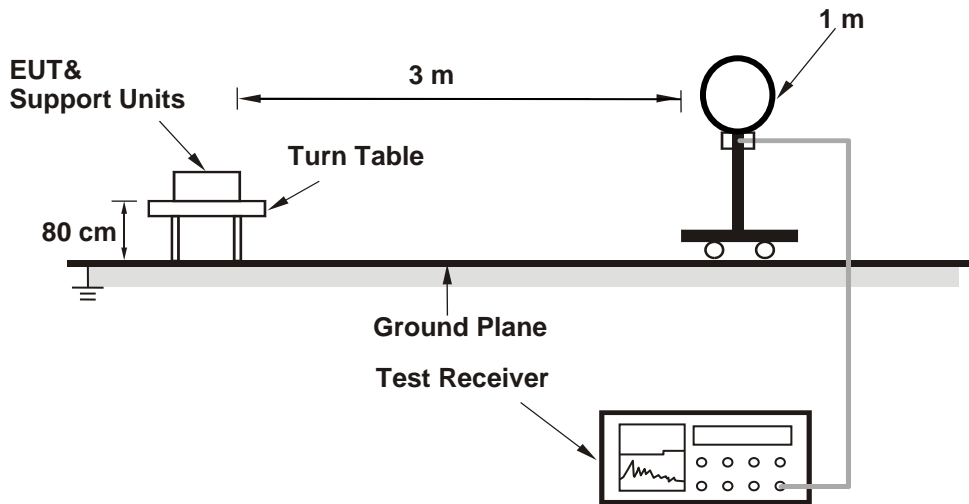

<Radiated Emission 30 MHz to 1 GHz>

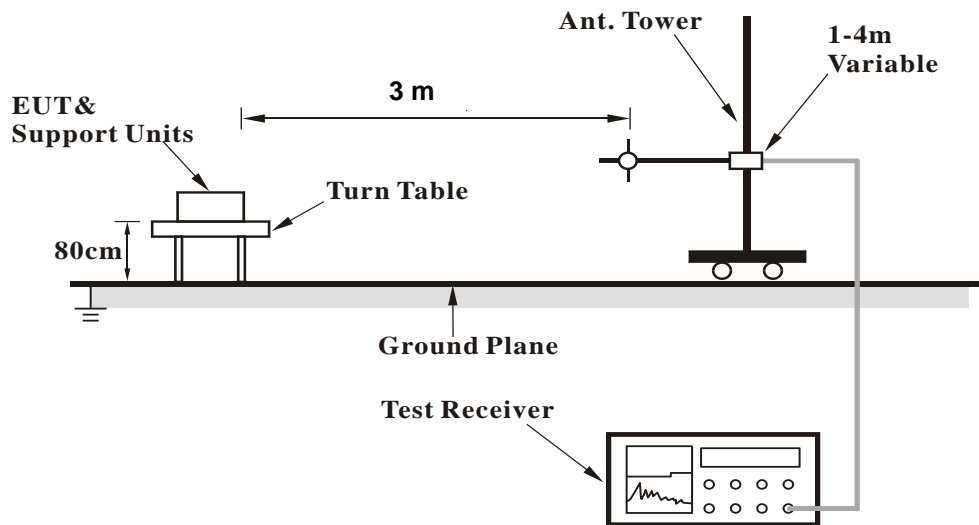

<Radiated Emission above 1 GHz>

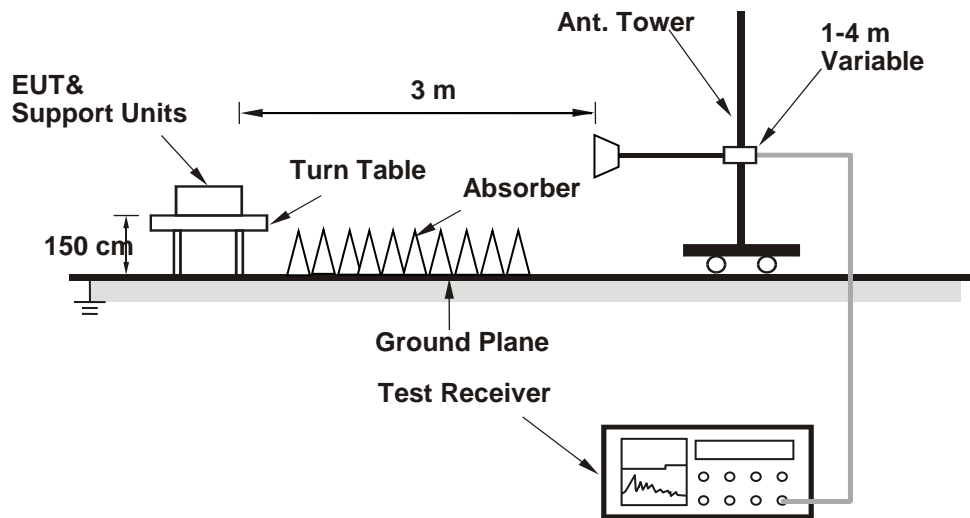

For the actual test configuration, please refer to the attached file (Test Setup Photo).

4.1.6 EUT Operating Conditions

- a. Placed the EUT on a testing table.
- b. Use the software to control the EUT under transmission condition continuously at specific channel frequency.

4.1.7 Test Results

Above 1 GHz Data :
802.11b

EUT Test Condition		Measurement Detail	
Channel	Channel 1	Frequency Range	1 GHz ~ 25 GHz
Input Power	120 Vac, 60 Hz	Detector Function	Peak (PK) Average (AV)
Environmental Conditions	25 deg. C, 65 % RH	Tested By	Cyril Chen

Antenna Polarity & Test Distance: Horizontal at 3 m								
Frequency (MHz)	Emission Level (dBuV/m)	Read Level (dBuV)	Factor (dB/m)	Limit (dBuV/m)	Margin (dB)	Antenna Height (cm)	Table Angle (Degree)	Remark
2373.036	41.75	47.62	-5.87	54	-12.25	163	133	Average
2373.036	51.68	57.55	-5.87	74	-22.32	163	133	Peak
2388.336	39.73	45.63	-5.9	54	-14.27	163	133	Average
2388.336	48.84	54.74	-5.9	74	-25.16	163	133	Peak
2412	97.66	103.61	-5.95	-----	-----	163	133	Average
2412	100.11	106.06	-5.95	-----	-----	163	133	Peak
4824	38.54	54.16	-15.62	54	-15.46	154	185	Average
4824	47.53	63.15	-15.62	74	-26.47	154	185	Peak
Antenna Polarity & Test Distance: Vertical at 3 m								
Frequency (MHz)	Emission Level (dBuV/m)	Read Level (dBuV)	Factor (dB/m)	Limit (dBuV/m)	Margin (dB)	Antenna Height (cm)	Table Angle (Degree)	Remark
2370.486	53.25	59.11	-5.86	54	-0.75	162	0	Average
2370.486	64.33	70.19	-5.86	74	-9.67	162	0	Peak
2388.744	49.91	55.81	-5.9	54	-4.09	162	0	Average
2388.744	58.45	64.35	-5.9	74	-15.55	162	0	Peak
2412	109.43	115.38	-5.95	-----	-----	162	0	Average
2412	111.94	117.89	-5.95	-----	-----	162	0	Peak
4824	37.44	53.06	-15.62	54	-16.56	163	148	Average
4824	47.33	62.95	-15.62	74	-26.67	163	148	Peak

Remarks:

- Emission Level = Read Level + Factor
Margin value = Emission level – Limit value
- 2412 MHz: Fundamental frequency.
- The emission levels of other frequencies were very low against the limit.

EUT Test Condition		Measurement Detail	
Channel	Channel 6	Frequency Range	1 GHz ~ 25 GHz
Input Power	120 Vac, 60 Hz	Detector Function	Peak (PK) Average (AV)
Environmental Conditions	25 deg. C, 65 % RH	Tested By	Cyril Chen

Antenna Polarity & Test Distance: Horizontal at 3 m								
Frequency (MHz)	Emission Level (dBuV/m)	Read Level (dBuV)	Factor (dB/m)	Limit (dBuV/m)	Margin (dB)	Antenna Height (cm)	Table Angle (Degree)	Remark
2389.61	42.25	48.15	-5.9	54	-11.75	159	132	Average
2389.61	51.73	57.63	-5.9	74	-22.27	159	132	Peak
2437	100.81	106.7	-5.89	-----	-----	159	132	Average
2437	103.45	109.34	-5.89	-----	-----	159	132	Peak
2484.61	39.2	44.9	-5.7	54	-14.8	159	132	Average
2484.61	48.52	54.22	-5.7	74	-25.48	159	132	Peak
4874	35.59	51.15	-15.56	54	-18.41	173	156	Average
4874	45.36	60.92	-15.56	74	-28.64	173	156	Peak
Antenna Polarity & Test Distance: Vertical at 3 m								
Frequency (MHz)	Emission Level (dBuV/m)	Read Level (dBuV)	Factor (dB/m)	Limit (dBuV/m)	Margin (dB)	Antenna Height (cm)	Table Angle (Degree)	Remark
2389.61	53.5	59.4	-5.9	54	-0.5	170	0	Average
2389.61	62.82	68.72	-5.9	74	-11.18	170	0	Peak
2437	114.19	120.08	-5.89	-----	-----	170	0	Average
2437	116.7	122.59	-5.89	-----	-----	170	0	Peak
2484.23	53.12	58.82	-5.7	54	-0.88	170	0	Average
2484.23	59.71	65.41	-5.7	74	-14.29	170	0	Peak
4874	36.59	52.15	-15.56	54	-17.41	188	222	Average
4874	45.66	61.22	-15.56	74	-28.34	188	222	Peak

Remarks:

- Emission Level = Read Level + Factor
Margin value = Emission level – Limit value
- 2437 MHz: Fundamental frequency.
- The emission levels of other frequencies were very low against the limit.

EUT Test Condition		Measurement Detail	
Channel	Channel 11	Frequency Range	1 GHz ~ 25 GHz
Input Power	120 Vac, 60 Hz	Detector Function	Peak (PK) Average (AV)
Environmental Conditions	25 deg. C, 65 % RH	Tested By	Cyril Chen

Antenna Polarity & Test Distance: Horizontal at 3 m								
Frequency (MHz)	Emission Level (dBuV/m)	Read Level (dBuV)	Factor (dB/m)	Limit (dBuV/m)	Margin (dB)	Antenna Height (cm)	Table Angle (Degree)	Remark
2462	100.25	106.06	-5.81	-----	-----	180	133	Average
2462	103.01	108.82	-5.81	-----	-----	180	133	Peak
2488.182	40.64	46.32	-5.68	54	-13.36	180	133	Average
2488.182	49.89	55.57	-5.68	74	-24.11	180	133	Peak
2497.644	44.95	50.55	-5.6	54	-9.05	180	133	Average
2497.644	51.17	56.77	-5.6	74	-22.83	180	133	Peak
4924	35.72	51.23	-15.51	54	-18.28	163	214	Average
4924	45.22	60.73	-15.51	74	-28.78	163	214	Peak
Antenna Polarity & Test Distance: Vertical at 3 m								
Frequency (MHz)	Emission Level (dBuV/m)	Read Level (dBuV)	Factor (dB/m)	Limit (dBuV/m)	Margin (dB)	Antenna Height (cm)	Table Angle (Degree)	Remark
2462	112.87	118.68	-5.81	-----	-----	151	0	Average
2462	115.44	121.25	-5.81	-----	-----	151	0	Peak
2485.142	51.16	56.86	-5.7	54	-2.84	151	0	Average
2485.142	60.62	66.32	-5.7	74	-13.38	151	0	Peak
2498.746	53.06	58.66	-5.6	54	-0.94	151	0	Average
2498.746	61.03	66.63	-5.6	74	-12.97	151	0	Peak
4924	39.99	55.5	-15.51	54	-14.01	185	166	Average
4924	49.02	64.53	-15.51	74	-24.98	185	166	Peak

Remarks:

- Emission Level = Read Level + Factor
Margin value = Emission level – Limit value
- 2462 MHz: Fundamental frequency.
- The emission levels of other frequencies were very low against the limit.

802.11g

EUT Test Condition		Measurement Detail	
Channel	Channel 1	Frequency Range	1 GHz ~ 25 GHz
Input Power	120 Vac, 60 Hz	Detector Function	Peak (PK) Average (AV)
Environmental Conditions	25 deg. C, 65 % RH	Tested By	Cyril Chen

Antenna Polarity & Test Distance: Horizontal at 3 m								
Frequency (MHz)	Emission Level (dBuV/m)	Read Level (dBuV)	Factor (dB/m)	Limit (dBuV/m)	Margin (dB)	Antenna Height (cm)	Table Angle (Degree)	Remark
2387.622	43.42	49.31	-5.89	54	-10.58	180	149	Average
2387.622	62.55	68.44	-5.89	74	-11.45	180	149	Peak
2412	96.54	102.49	-5.95	-----	-----	180	149	Average
2412	102.86	108.81	-5.95	-----	-----	180	149	Peak
4824	34.51	50.13	-15.62	54	-19.49	144	168	Average
4824	43.84	59.46	-15.62	74	-30.16	144	168	Peak
Antenna Polarity & Test Distance: Vertical at 3 m								
Frequency (MHz)	Emission Level (dBuV/m)	Read Level (dBuV)	Factor (dB/m)	Limit (dBuV/m)	Margin (dB)	Antenna Height (cm)	Table Angle (Degree)	Remark
2365.896	53.36	59.22	-5.86	54	-0.64	173	0	Average
2365.896	62.45	68.31	-5.86	74	-11.55	173	0	Peak
2412	106.44	112.39	-5.95	-----	-----	173	0	Average
2412	113.29	119.24	-5.95	-----	-----	173	0	Peak
4824	34.55	50.17	-15.62	54	-19.45	177	169	Average
4824	44.2	59.82	-15.62	74	-29.8	177	169	Peak

Remarks:

- Emission Level = Read Level + Factor
Margin value = Emission level – Limit value
- 2412 MHz: Fundamental frequency.
- The emission levels of other frequencies were very low against the limit.

EUT Test Condition		Measurement Detail	
Channel	Channel 6	Frequency Range	1 GHz ~ 25 GHz
Input Power	120 Vac, 60 Hz	Detector Function	Peak (PK) Average (AV)
Environmental Conditions	25 deg. C, 65 % RH	Tested By	Cyril Chen

Antenna Polarity & Test Distance: Horizontal at 3 m								
Frequency (MHz)	Emission Level (dBuV/m)	Read Level (dBuV)	Factor (dB/m)	Limit (dBuV/m)	Margin (dB)	Antenna Height (cm)	Table Angle (Degree)	Remark
2324.82	43.32	49.01	-5.69	54	-10.68	127	282	Average
2324.82	49.09	54.78	-5.69	74	-24.91	127	282	Peak
2388.85	42.37	48.27	-5.9	54	-11.63	127	282	Average
2388.85	52.03	57.93	-5.9	74	-21.97	127	282	Peak
2437	95.27	101.16	-5.89	-----	-----	127	282	Average
2437	101.86	107.75	-5.89	-----	-----	127	282	Peak
2486.13	38.46	44.16	-5.7	54	-15.54	127	282	Average
2486.13	47.33	53.03	-5.7	74	-26.67	127	282	Peak
Antenna Polarity & Test Distance: Vertical at 3 m								
Frequency (MHz)	Emission Level (dBuV/m)	Read Level (dBuV)	Factor (dB/m)	Limit (dBuV/m)	Margin (dB)	Antenna Height (cm)	Table Angle (Degree)	Remark
2390	52.74	58.66	-5.92	54	-1.26	178	356	Average
2390	60.47	66.39	-5.92	74	-13.53	178	356	Peak
2437	105.12	111.01	-5.89	-----	-----	178	356	Average
2437	111.62	117.51	-5.89	-----	-----	178	356	Peak
2483.5	49.48	55.18	-5.7	54	-4.52	178	356	Average
2483.5	57.89	63.59	-5.7	74	-16.11	178	356	Peak
4874	34.79	50.35	-15.56	54	-19.21	106	188	Average
4874	43.83	59.39	-15.56	74	-30.17	106	188	Peak

Remarks:

- Emission Level = Read Level + Factor
Margin value = Emission level – Limit value
- 2437 MHz: Fundamental frequency.
- The emission levels of other frequencies were very low against the limit.

EUT Test Condition		Measurement Detail	
Channel	Channel 11	Frequency Range	1 GHz ~ 25 GHz
Input Power	120 Vac, 60 Hz	Detector Function	Peak (PK) Average (AV)
Environmental Conditions	25 deg. C, 65 % RH	Tested By	Cyril Chen

Antenna Polarity & Test Distance: Horizontal at 3 m								
Frequency (MHz)	Emission Level (dBuV/m)	Read Level (dBuV)	Factor (dB/m)	Limit (dBuV/m)	Margin (dB)	Antenna Height (cm)	Table Angle (Degree)	Remark
2462	93.24	99.05	-5.81	-----	-----	128	239	Average
2462	100.48	106.29	-5.81	-----	-----	128	239	Peak
2483.66	41.82	47.52	-5.7	54	-12.18	128	239	Average
2483.66	60.89	66.59	-5.7	74	-13.11	128	239	Peak
4924	34.96	50.47	-15.51	54	-19.04	136	267	Average
4924	44.45	59.96	-15.51	74	-29.55	136	267	Peak
Antenna Polarity & Test Distance: Vertical at 3 m								
Frequency (MHz)	Emission Level (dBuV/m)	Read Level (dBuV)	Factor (dB/m)	Limit (dBuV/m)	Margin (dB)	Antenna Height (cm)	Table Angle (Degree)	Remark
2462	105.97	111.78	-5.81	-----	-----	170	0	Average
2462	112.48	118.29	-5.81	-----	-----	170	0	Peak
2483.5	52.68	58.38	-5.7	54	-1.32	170	0	Average
2483.5	71.96	77.66	-5.7	74	-2.04	170	0	Peak
4924	33.85	49.36	-15.51	54	-20.15	102	163	Average
4924	43.19	58.7	-15.51	74	-30.81	102	163	Peak

Remarks:

- Emission Level = Read Level + Factor
Margin value = Emission level – Limit value
- 2462 MHz: Fundamental frequency.
- The emission levels of other frequencies were very low against the limit.

802.11n (HT20)

EUT Test Condition		Measurement Detail	
Channel	Channel 1	Frequency Range	1 GHz ~ 25 GHz
Input Power	120 Vac, 60 Hz	Detector Function	Peak (PK) Average (AV)
Environmental Conditions	25 deg. C, 65 % RH	Tested By	Cyril Chen

Antenna Polarity & Test Distance: Horizontal at 3 m								
Frequency (MHz)	Emission Level (dBuV/m)	Read Level (dBuV)	Factor (dB/m)	Limit (dBuV/m)	Margin (dB)	Antenna Height (cm)	Table Angle (Degree)	Remark
2366.712	41.54	47.4	-5.86	54	-12.46	132	226	Average
2366.712	52.51	58.37	-5.86	74	-21.49	132	226	Peak
2390	39.95	45.87	-5.92	54	-14.05	132	226	Average
2390	49.9	55.82	-5.92	74	-24.1	132	226	Peak
2412	94.1	100.05	-5.95	-----	-----	132	226	Average
2412	100.66	106.61	-5.95	-----	-----	132	226	Peak
4824	34.42	50.04	-15.62	54	-19.58	148	139	Average
4824	43.29	58.91	-15.62	74	-30.71	148	139	Peak
Antenna Polarity & Test Distance: Vertical at 3 m								
Frequency (MHz)	Emission Level (dBuV/m)	Read Level (dBuV)	Factor (dB/m)	Limit (dBuV/m)	Margin (dB)	Antenna Height (cm)	Table Angle (Degree)	Remark
2367.324	53.23	59.09	-5.86	54	-0.77	183	360	Average
2367.324	62.5	68.36	-5.86	74	-11.5	183	360	Peak
2390	49.26	55.18	-5.92	54	-4.74	183	360	Average
2390	60.53	66.45	-5.92	74	-13.47	183	360	Peak
2412	105.34	111.29	-5.95	-----	-----	183	360	Average
2412	112.66	118.61	-5.95	-----	-----	183	360	Peak
4824	34.06	49.68	-15.62	54	-19.94	203	2	Average
4824	42.71	58.33	-15.62	74	-31.29	203	2	Peak

Remarks:

- Emission Level = Read Level + Factor
Margin value = Emission level – Limit value
- 2412 MHz: Fundamental frequency.
- The emission levels of other frequencies were very low against the limit.

EUT Test Condition		Measurement Detail	
Channel	Channel 6	Frequency Range	1 GHz ~ 25 GHz
Input Power	120 Vac, 60 Hz	Detector Function	Peak (PK) Average (AV)
Environmental Conditions	25 deg. C, 65 % RH	Tested By	Cyril Chen

Antenna Polarity & Test Distance: Horizontal at 3 m								
Frequency (MHz)	Emission Level (dBuV/m)	Read Level (dBuV)	Factor (dB/m)	Limit (dBuV/m)	Margin (dB)	Antenna Height (cm)	Table Angle (Degree)	Remark
2390	42.15	48.07	-5.92	54	-11.85	140	227	Average
2390	51.5	57.42	-5.92	74	-22.5	140	227	Peak
2437	97.33	103.22	-5.89	-----	-----	140	227	Average
2437	104.29	110.18	-5.89	-----	-----	140	227	Peak
2483.5	39.26	44.96	-5.7	54	-14.74	140	227	Average
2483.5	48.4	54.1	-5.7	74	-25.6	140	227	Peak
4874	34.76	50.32	-15.56	54	-19.24	167	241	Average
4874	42.95	58.51	-15.56	74	-31.05	167	241	Peak
Antenna Polarity & Test Distance: Vertical at 3 m								
Frequency (MHz)	Emission Level (dBuV/m)	Read Level (dBuV)	Factor (dB/m)	Limit (dBuV/m)	Margin (dB)	Antenna Height (cm)	Table Angle (Degree)	Remark
2390	52.6	58.52	-5.92	54	-1.4	151	0	Average
2390	62.46	68.38	-5.92	74	-11.54	151	0	Peak
2437	107.96	113.85	-5.89	-----	-----	151	0	Average
2437	114.75	120.64	-5.89	-----	-----	151	0	Peak
2483.5	51.47	57.17	-5.7	54	-2.53	151	0	Average
2483.5	61.42	67.12	-5.7	74	-12.58	151	0	Peak
4874	35.57	51.13	-15.56	54	-18.43	158	22	Average
4874	43.57	59.13	-15.56	74	-30.43	158	22	Peak

Remarks:

- Emission Level = Read Level + Factor
Margin value = Emission level – Limit value
- 2437 MHz: Fundamental frequency.
- The emission levels of other frequencies were very low against the limit.

EUT Test Condition		Measurement Detail	
Channel	Channel 11	Frequency Range	1 GHz ~ 25 GHz
Input Power	120 Vac, 60 Hz	Detector Function	Peak (PK) Average (AV)
Environmental Conditions	25 deg. C, 65 % RH	Tested By	Cyril Chen

Antenna Polarity & Test Distance: Horizontal at 3 m								
Frequency (MHz)	Emission Level (dBuV/m)	Read Level (dBuV)	Factor (dB/m)	Limit (dBuV/m)	Margin (dB)	Antenna Height (cm)	Table Angle (Degree)	Remark
2462	94.25	100.06	-5.81	-----	-----	196	198	Average
2462	100.9	106.71	-5.81	-----	-----	196	198	Peak
2483.66	40.84	46.54	-5.7	54	-13.16	196	198	Average
2483.66	59.71	65.41	-5.7	74	-14.29	196	198	Peak
4924	34.97	50.48	-15.51	54	-19.03	153	165	Average
4924	43.57	59.08	-15.51	74	-30.43	153	165	Peak
Antenna Polarity & Test Distance: Vertical at 3 m								
Frequency (MHz)	Emission Level (dBuV/m)	Read Level (dBuV)	Factor (dB/m)	Limit (dBuV/m)	Margin (dB)	Antenna Height (cm)	Table Angle (Degree)	Remark
2462	107.24	113.05	-5.81	-----	-----	163	40	Average
2462	114.06	119.87	-5.81	-----	-----	163	40	Peak
2484.23	53.15	58.85	-5.7	54	-0.85	163	40	Average
2484.23	73.68	79.38	-5.7	74	-0.32	163	40	Peak
4924	33.64	49.15	-15.51	54	-20.36	146	255	Average
4924	42.4	57.91	-15.51	74	-31.6	146	255	Peak

Remarks:

- Emission Level = Read Level + Factor
Margin value = Emission level – Limit value
- 2462 MHz: Fundamental frequency.
- The emission levels of other frequencies were very low against the limit.

802.11n (HT40)

EUT Test Condition		Measurement Detail	
Channel	Channel 3	Frequency Range	1 GHz ~ 25 GHz
Input Power	120 Vac, 60 Hz	Detector Function	Peak (PK) Average (AV)
Environmental Conditions	25 deg. C, 65 % RH	Tested By	Cyril Chen

Antenna Polarity & Test Distance: Horizontal at 3 m								
Frequency (MHz)	Emission Level (dBuV/m)	Read Level (dBuV)	Factor (dB/m)	Limit (dBuV/m)	Margin (dB)	Antenna Height (cm)	Table Angle (Degree)	Remark
2388.09	42.98	48.87	-5.89	54	-11.02	126	200	Average
2388.09	63.85	69.74	-5.89	74	-10.15	126	200	Peak
2422	91.88	97.76	-5.88	-----	-----	126	200	Average
2422	98.75	104.63	-5.88	-----	-----	126	200	Peak
2483.5	37.01	42.71	-5.7	54	-16.99	126	200	Average
2483.5	50.91	56.61	-5.7	74	-23.09	126	200	Peak
4844	33.51	49.1	-15.59	54	-20.49	144	193	Average
4844	42.25	57.84	-15.59	74	-31.75	144	193	Peak
Antenna Polarity & Test Distance: Vertical at 3 m								
Frequency (MHz)	Emission Level (dBuV/m)	Read Level (dBuV)	Factor (dB/m)	Limit (dBuV/m)	Margin (dB)	Antenna Height (cm)	Table Angle (Degree)	Remark
2388.66	53.6	59.5	-5.9	54	-0.4	159	36	Average
2388.66	73.51	79.41	-5.9	74	-0.49	159	36	Peak
2422	103.55	109.43	-5.88	-----	-----	159	36	Average
2422	110.09	115.97	-5.88	-----	-----	159	36	Peak
2486.89	45.47	51.17	-5.7	54	-8.53	159	36	Average
2486.89	65.63	71.33	-5.7	74	-8.37	159	36	Peak
4844	33.9	49.49	-15.59	54	-20.1	190	224	Average
4844	42.91	58.5	-15.59	74	-31.09	190	224	Peak

Remarks:

- Emission Level = Read Level + Factor
Margin value = Emission level – Limit value
- 2422 MHz: Fundamental frequency.
- The emission levels of other frequencies were very low against the limit.

EUT Test Condition		Measurement Detail	
Channel	Channel 6	Frequency Range	1 GHz ~ 25 GHz
Input Power	120 Vac, 60 Hz	Detector Function	Peak (PK) Average (AV)
Environmental Conditions	25 deg. C, 65 % RH	Tested By	Cyril Chen

Antenna Polarity & Test Distance: Horizontal at 3 m								
Frequency (MHz)	Emission Level (dBuV/m)	Read Level (dBuV)	Factor (dB/m)	Limit (dBuV/m)	Margin (dB)	Antenna Height (cm)	Table Angle (Degree)	Remark
2390	40.82	46.74	-5.92	54	-13.18	130	182	Average
2390	58.39	64.31	-5.92	74	-15.61	130	182	Peak
2437	92.58	98.47	-5.89	-----	-----	130	182	Average
2437	99.26	105.15	-5.89	-----	-----	130	182	Peak
2483.5	38.54	44.24	-5.7	54	-15.46	130	182	Average
2483.5	53.64	59.34	-5.7	74	-20.36	130	182	Peak
4874	34.28	49.84	-15.56	54	-19.72	166	192	Average
4874	42.66	58.22	-15.56	74	-31.34	166	192	Peak
Antenna Polarity & Test Distance: Vertical at 3 m								
Frequency (MHz)	Emission Level (dBuV/m)	Read Level (dBuV)	Factor (dB/m)	Limit (dBuV/m)	Margin (dB)	Antenna Height (cm)	Table Angle (Degree)	Remark
2389.8	53.28	59.2	-5.92	54	-0.72	178	324	Average
2389.8	71.4	77.32	-5.92	74	-2.6	178	324	Peak
2437	105.35	111.24	-5.89	-----	-----	178	324	Average
2437	112.26	118.15	-5.89	-----	-----	178	324	Peak
2483.5	51.21	56.91	-5.7	54	-2.79	178	324	Average
2483.5	68.71	74.41	-5.7	74	-5.29	178	324	Peak
4874	33.39	48.95	-15.56	54	-20.61	169	139	Average
4874	42.02	57.58	-15.56	74	-31.98	169	139	Peak

Remarks:

- Emission Level = Read Level + Factor
Margin value = Emission level – Limit value
- 2437 MHz: Fundamental frequency.
- The emission levels of other frequencies were very low against the limit.

EUT Test Condition		Measurement Detail	
Channel	Channel 9	Frequency Range	1 GHz ~ 25 GHz
Input Power	120 Vac, 60 Hz	Detector Function	Peak (PK) Average (AV)
Environmental Conditions	25 deg. C, 65 % RH	Tested By	Cyril Chen

Antenna Polarity & Test Distance: Horizontal at 3 m								
Frequency (MHz)	Emission Level (dBuV/m)	Read Level (dBuV)	Factor (dB/m)	Limit (dBuV/m)	Margin (dB)	Antenna Height (cm)	Table Angle (Degree)	Remark
2325.2	42.17	47.87	-5.7	54	-11.83	165	125	Average
2325.2	49.14	54.84	-5.7	74	-24.86	165	125	Peak
2452	89.27	95.09	-5.82	-----	-----	165	125	Average
2452	97.35	103.17	-5.82	-----	-----	165	125	Peak
2483.5	41.71	47.41	-5.7	54	-12.29	165	125	Average
2483.5	59.01	64.71	-5.7	74	-14.99	165	125	Peak
4904	33.98	49.53	-15.55	54	-20.02	187	148	Average
4904	42.66	58.21	-15.55	74	-31.34	187	148	Peak
Antenna Polarity & Test Distance: Vertical at 3 m								
Frequency (MHz)	Emission Level (dBuV/m)	Read Level (dBuV)	Factor (dB/m)	Limit (dBuV/m)	Margin (dB)	Antenna Height (cm)	Table Angle (Degree)	Remark
2325.01	47.44	53.14	-5.7	54	-6.56	135	0	Average
2325.01	56.12	61.82	-5.7	74	-17.88	135	0	Peak
2452	102.77	108.59	-5.82	-----	-----	135	0	Average
2452	109.39	115.21	-5.82	-----	-----	135	0	Peak
2483.85	53.23	58.93	-5.7	54	-0.77	135	0	Average
2483.85	73.03	78.73	-5.7	74	-0.97	135	0	Peak
4904	33.94	49.49	-15.55	54	-20.06	163	254	Average
4904	42.97	58.52	-15.55	74	-31.03	163	254	Peak

Remarks:

- Emission Level = Read Level + Factor
Margin value = Emission level – Limit value
- 2452 MHz: Fundamental frequency.
- The emission levels of other frequencies were very low against the limit.

9 kHz ~ 30 MHz Data:

The amplitude of spurious emissions attenuated more than 20 dB below the permissible value is not required to be report.

30 MHz ~ 1 GHz Worst-Case Data:

Mode A

802.11b

EUT Test Condition		Measurement Detail	
Channel	Channel 6	Frequency Range	30 MHz ~ 1 GHz
Input Power	120 Vac, 60 Hz	Detector Function	Peak (PK) Quasi-peak (QP)
Environmental Conditions	25 deg. C, 65 % RH	Tested By	Tim Chen

Horizontal

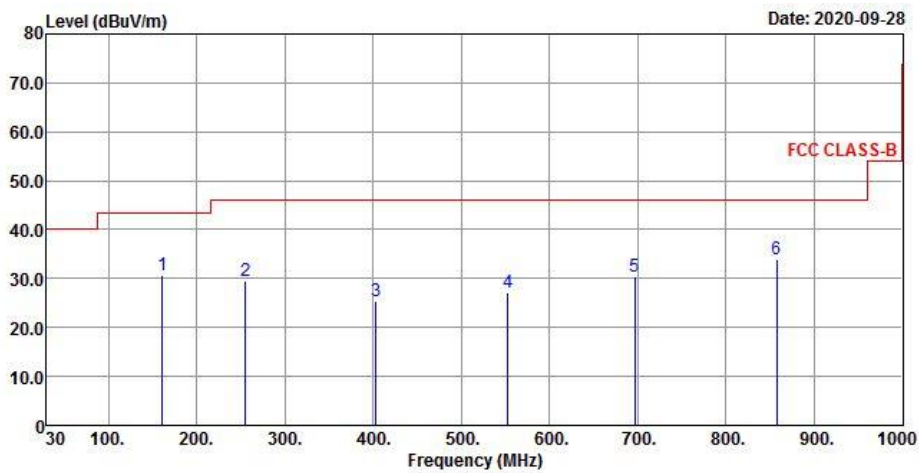

Vertical

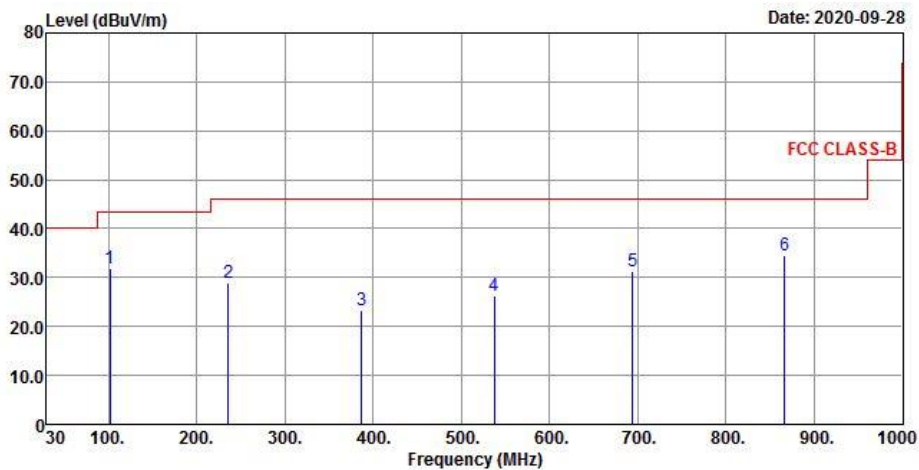

Antenna Polarity & Test Distance: Horizontal at 3 m								
Frequency (MHz)	Emission Level (dBuV/m)	Read Level (dBuV)	Factor (dB/m)	Limit (dBuV/m)	Margin (dB)	Antenna Height (cm)	Table Angle (Degree)	Remark
160.95	30.63	42.49	-11.86	43.5	-12.87	279	312	QP
255.04	29.46	42.35	-12.89	46	-16.54	166	27	QP
403.45	25.33	33.6	-8.27	46	-20.67	195	36	QP
552.83	27.11	31.49	-4.38	46	-18.89	147	168	QP
696.39	30.39	31.1	-0.71	46	-15.61	184	210	QP
857.41	33.9	31.35	2.55	46	-12.1	266	132	QP
Antenna Polarity & Test Distance: Vertical at 3 m								
Frequency (MHz)	Emission Level (dBuV/m)	Read Level (dBuV)	Factor (dB/m)	Limit (dBuV/m)	Margin (dB)	Antenna Height (cm)	Table Angle (Degree)	Remark
101.78	31.87	47.63	-15.76	43.5	-11.63	236	74	QP
235.64	28.9	42.59	-13.69	46	-17.1	306	81	QP
386.96	23.29	31.9	-8.61	46	-22.71	196	160	QP
537.31	26.33	31.15	-4.82	46	-19.67	233	188	QP
694.45	31.22	31.96	-0.74	46	-14.78	169	46	QP
866.14	34.45	31.83	2.62	46	-11.55	256	79	QP

Remarks:

- Emission Level = Read Level + Factor
Margin value = Emission level – Limit value.
- The emission levels of other frequencies were very low against the limit.

Mode B
802.11b

EUT Test Condition		Measurement Detail	
Channel	Channel 6	Frequency Range	30 MHz ~ 1 GHz
Input Power	120 Vac, 60 Hz	Detector Function	Peak (PK) Quasi-peak (QP)
Environmental Conditions	25 deg. C, 65 % RH	Tested By	Tim Chen

Horizontal

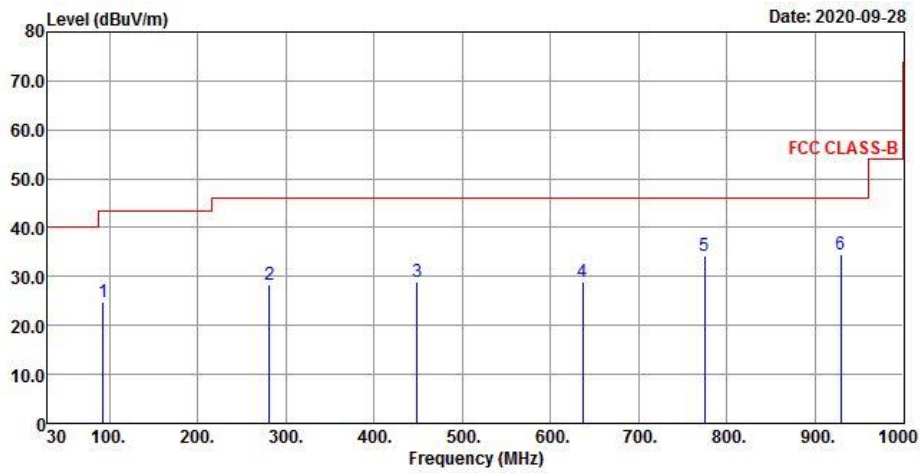

Vertical

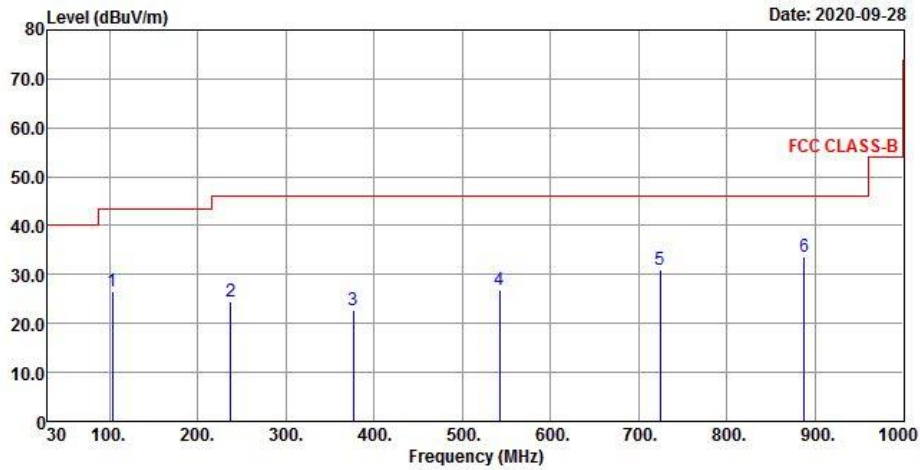

Antenna Polarity & Test Distance: Horizontal at 3 m								
Frequency (MHz)	Emission Level (dBuV/m)	Read Level (dBuV)	Factor (dB/m)	Limit (dBuV/m)	Margin (dB)	Antenna Height (cm)	Table Angle (Degree)	Remark
93.05	24.81	41.99	-17.18	43.5	-18.69	224	76	QP
281.23	28.31	40	-11.69	46	-17.69	182	64	QP
449.04	29.07	35.54	-6.47	46	-16.93	238	175	QP
636.25	28.97	30.7	-1.73	46	-17.03	146	59	QP
774.96	34.32	32.88	1.44	46	-11.68	177	95	QP
929.19	34.44	31.02	3.42	46	-11.56	322	179	QP
Antenna Polarity & Test Distance: Vertical at 3 m								
Frequency (MHz)	Emission Level (dBuV/m)	Read Level (dBuV)	Factor (dB/m)	Limit (dBuV/m)	Margin (dB)	Antenna Height (cm)	Table Angle (Degree)	Remark
103.72	26.45	41.87	-15.42	43.5	-17.05	283	136	QP
237.58	24.36	37.9	-13.54	46	-21.64	165	69	QP
376.29	22.61	31.43	-8.82	46	-23.39	152	98	QP
542.16	26.99	31.67	-4.68	46	-19.01	133	156	QP
724.52	30.9	30.9	0	46	-15.1	350	45	QP
887.48	33.77	31.01	2.76	46	-12.23	317	155	QP

Remarks:

- Emission Level = Read Level + Factor
Margin value = Emission level – Limit value.
- The emission levels of other frequencies were very low against the limit.

4.2 Conducted Emission Measurement

4.2.1 Limits of Conducted Emission Measurement

Frequency (MHz)	Conducted Limit (dBuV)	
	Quasi-Peak	Average
0.15 - 0.5	66 - 56	56 - 46
0.50 - 5.0	56	46
5.0 - 30.0	60	50

- Note: 1. The lower limit shall apply at the transition frequencies.
 2. The limit decreases in line with the logarithm of the frequency in the range of 0.15 to 0.50 MHz.

4.2.2 Test Instruments

Description & Manufacturer	Model No.	Serial No.	Date of Calibration	Due Date of Calibration
Test Receiver ROHDE & SCHWARZ	ESCI	100613	Dec. 11, 2019	Dec. 10, 2020
RF signal cable Woken	5D-FB	Cable-cond1-01	Sep. 04, 2020	Sep. 03, 2021
LISN/AMN ROHDE & SCHWARZ (EUT)	ENV216	101826	Feb. 20, 2020	Feb. 19, 2021
LISN/AMN ROHDE & SCHWARZ (Peripheral)	ESH3-Z5	100311	Aug. 28, 2020	Aug. 27, 2021
V-LISN/AMN SCHWARZBECK (Peripheral)	NNBL 8226-2	8226-142	Jul. 31, 2020	Jul. 30, 2021
Software ADT	BV ADT_Cond_ V7.3.7.4	NA	NA	NA

- Note: 1. The calibration interval of the above test instruments is 12 months and the calibrations are traceable to NML/ROC and NIST/USA.
 2. The test was performed in HwaYa Shielded Room 1.
 3. The VCCI Site Registration No. is C-12040.

4.2.3 Test Procedures

- a. The EUT was placed 0.4 meters from the conducting wall of the shielded room with EUT being connected to the power mains through a line impedance stabilization network (LISN). Other support units were connected to the power mains through another LISN. The two LISNs provide 50 ohm/50 uH of coupling impedance for the measuring instrument.
- b. Both lines of the power mains connected to the EUT were checked for maximum conducted interference.
- c. The frequency range from 150 kHz to 30 MHz was searched. Emission levels under (Limit – 20 dB) was not recorded.

Note: The resolution bandwidth and video bandwidth of test receiver is 9 kHz for quasi-peak detection (QP) and average detection (AV) at frequency 0.15 MHz – 30 MHz.

4.2.4 Deviation from Test Standard

No deviation.

4.2.5 Test Setup

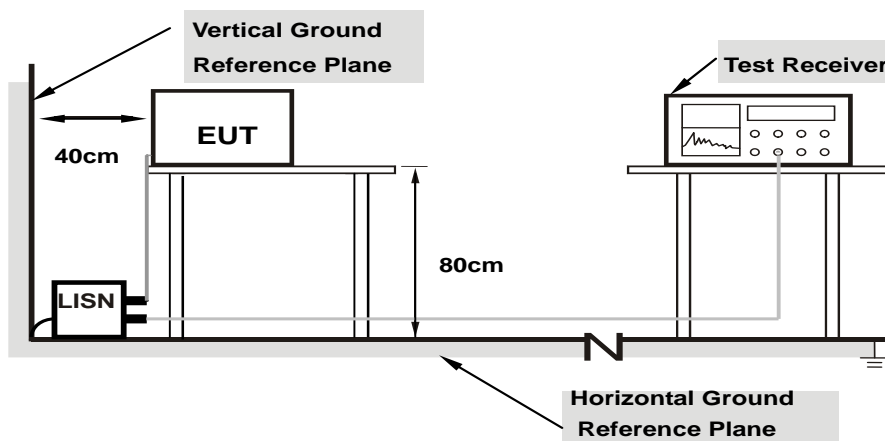

Note: 1.Support units were connected to second LISN.

For the actual test configuration, please refer to the attached file (Test Setup Photo).

4.2.6 EUT Operating Conditions

- a. Placed the EUT on a testing table.
- b. Use the software to control the EUT under transmission condition continuously at specific channel frequency.

4.2.7 Test Results

Mode A

Frequency Range	150kHz ~ 30MHz	Detector Function & Bandwidth	Quasi-Peak (QP) / Average (AV), 9kHz
Input Power	120Vac, 60Hz	Environmental Conditions	25°C, 65%RH

Phase Of Power : Line (L)										
No	Frequency (MHz)	Correction Factor (dB)	Reading Value (dBuV)		Emission Level (dBuV)		Limit (dBuV)		Margin (dB)	
			Q.P.	AV.	Q.P.	AV.	Q.P.	AV.	Q.P.	AV.
1	0.19316	9.66	36.47	25.89	46.13	35.55	63.90	53.90	-17.77	-18.35
2	0.31949	9.66	34.46	25.47	44.12	35.13	59.72	49.72	-15.60	-14.59
3	0.39000	9.66	39.03	32.84	48.69	42.50	58.06	48.06	-9.37	-5.56
4	2.14600	9.70	26.38	17.38	36.08	27.08	56.00	46.00	-19.92	-18.92
5	14.09400	9.84	19.38	11.51	29.22	21.35	60.00	50.00	-30.78	-28.65
6	21.68200	9.85	23.29	19.19	33.14	29.04	60.00	50.00	-26.86	-20.96

Remarks:

1. Q.P. and AV. are abbreviations of quasi-peak and average individually.
2. The emission levels of other frequencies were very low against the limit.
3. Margin value = Emission level – Limit value
4. Correction factor = Insertion loss + Cable loss
5. Emission Level = Correction Factor + Reading Value

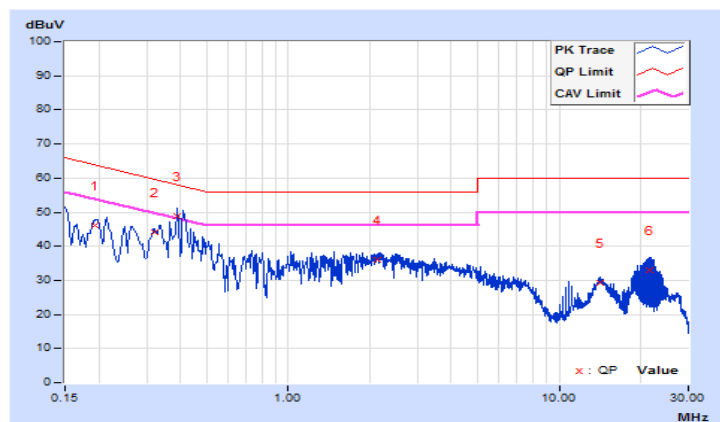

Frequency Range	150kHz ~ 30MHz	Detector Function & Bandwidth	Quasi-Peak (QP) / Average (AV), 9kHz
Input Power	120Vac, 60Hz	Environmental Conditions	25°C, 65%RH

Phase Of Power : Neutral (N)										
No	Frequency (MHz)	Correction Factor (dB)	Reading Value (dBuV)		Emission Level (dBuV)		Limit (dBuV)		Margin (dB)	
			Q.P.	AV.	Q.P.	AV.	Q.P.	AV.	Q.P.	AV.
1	0.15000	9.68	40.61	30.12	50.29	39.80	66.00	56.00	-15.71	-16.20
2	0.26200	9.68	34.58	26.16	44.26	35.84	61.37	51.37	-17.11	-15.53
3	0.39400	9.68	40.16	36.12	49.84	45.80	57.98	47.98	-8.14	-2.18
4	0.80976	9.69	26.69	21.30	36.38	30.99	56.00	46.00	-19.62	-15.01
5	14.48200	9.92	19.19	11.78	29.11	21.70	60.00	50.00	-30.89	-28.30
6	22.21800	9.98	27.26	27.12	37.24	37.10	60.00	50.00	-22.76	-12.90

Remarks:

1. Q.P. and AV. are abbreviations of quasi-peak and average individually.
2. The emission levels of other frequencies were very low against the limit.
3. Margin value = Emission level – Limit value
4. Correction factor = Insertion loss + Cable loss
5. Emission Level = Correction Factor + Reading Value

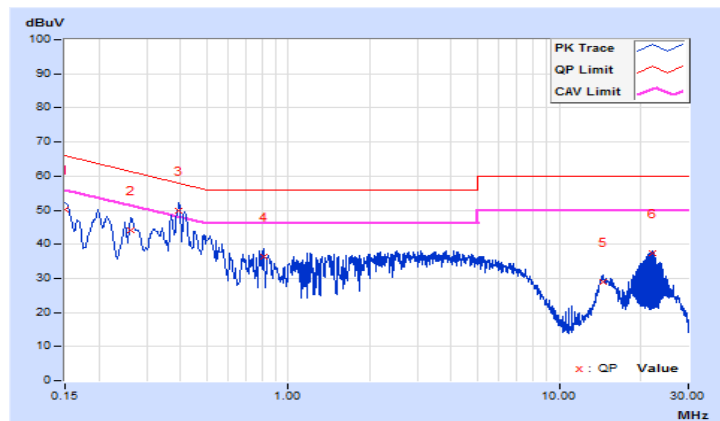

Mode B

Frequency Range	150kHz ~ 30MHz	Detector Function & Bandwidth	Quasi-Peak (QP) / Average (AV), 9kHz
Input Power	120Vac, 60Hz	Environmental Conditions	25°C, 65%RH

Phase Of Power : Line (L)										
No	Frequency (MHz)	Correction Factor (dB)	Reading Value (dBuV)		Emission Level (dBuV)		Limit (dBuV)		Margin (dB)	
			Q.P.	AV.	Q.P.	AV.	Q.P.	AV.	Q.P.	AV.
1	0.17400	9.65	24.17	1.31	33.82	10.96	64.77	54.77	-30.95	-43.81
2	0.19800	9.66	18.64	1.95	28.30	11.61	63.69	53.69	-35.39	-42.08
3	0.22200	9.66	11.49	0.52	21.15	10.18	62.74	52.74	-41.59	-42.56
4	0.59400	9.66	7.16	1.74	16.82	11.40	56.00	46.00	-39.18	-34.60
5	2.73800	9.71	8.39	1.03	18.10	10.74	56.00	46.00	-37.90	-35.26
6	16.83800	9.85	7.10	3.71	16.95	13.56	60.00	50.00	-43.05	-36.44

Remarks:

1. Q.P. and AV. are abbreviations of quasi-peak and average individually.
2. The emission levels of other frequencies were very low against the limit.
3. Margin value = Emission level – Limit value
4. Correction factor = Insertion loss + Cable loss
5. Emission Level = Correction Factor + Reading Value

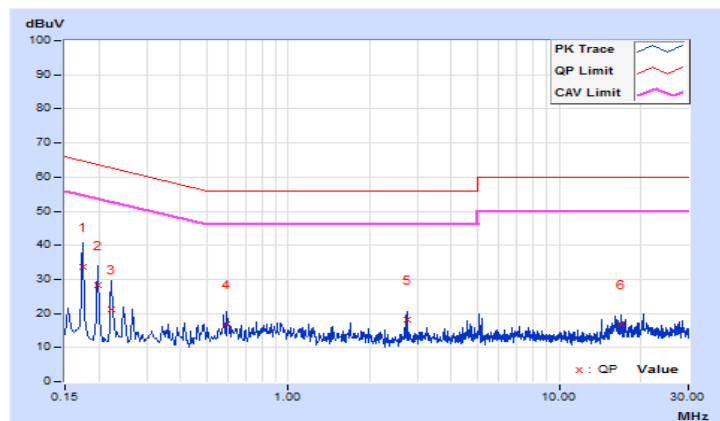

Frequency Range	150kHz ~ 30MHz	Detector Function & Bandwidth	Quasi-Peak (QP) / Average (AV), 9kHz
Input Power	120Vac, 60Hz	Environmental Conditions	25°C, 65%RH

Phase Of Power : Neutral (N)										
No	Frequency (MHz)	Correction Factor (dB)	Reading Value (dBuV)		Emission Level (dBuV)		Limit (dBuV)		Margin (dB)	
			Q.P.	AV.	Q.P.	AV.	Q.P.	AV.	Q.P.	AV.
1	0.15800	9.68	26.21	2.00	35.89	11.68	65.57	55.57	-29.68	-43.89
2	0.17400	9.68	24.20	1.32	33.88	11.00	64.77	54.77	-30.89	-43.77
3	0.19800	9.68	18.62	1.82	28.30	11.50	63.69	53.69	-35.39	-42.19
4	0.59400	9.68	7.72	2.20	17.40	11.88	56.00	46.00	-38.60	-34.12
5	1.38200	9.71	10.30	0.45	20.01	10.16	56.00	46.00	-35.99	-35.84
6	16.22600	9.94	10.70	6.51	20.64	16.45	60.00	50.00	-39.36	-33.55

Remarks:

1. Q.P. and AV. are abbreviations of quasi-peak and average individually.
2. The emission levels of other frequencies were very low against the limit.
3. Margin value = Emission level – Limit value
4. Correction factor = Insertion loss + Cable loss
5. Emission Level = Correction Factor + Reading Value

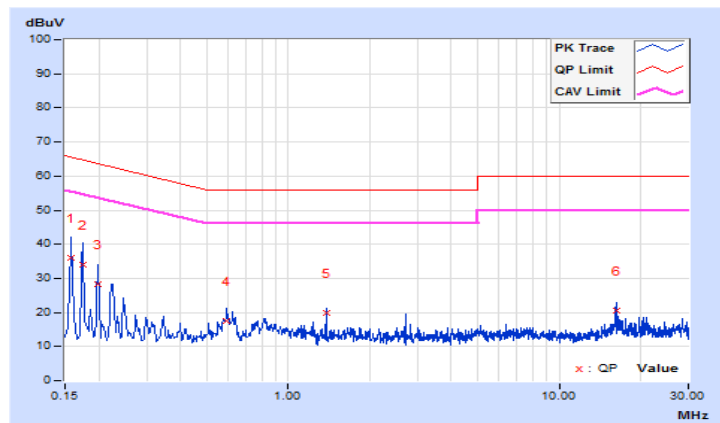

4.3 6 dB Bandwidth Measurement

4.3.1 Limits of 6 dB Bandwidth Measurement

The minimum of 6 dB Bandwidth Measurement is 0.5 MHz.

4.3.2 Test Setup

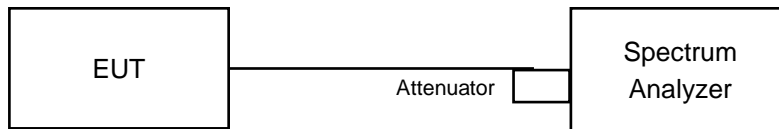

4.3.3 Test Instruments

Refer to section 4.1.2 to get information of above instrument.

4.3.4 Test Procedure

- Set resolution bandwidth (RBW) = 100 kHz
- Set the video bandwidth (VBW) $\geq 3 \times$ RBW, Detector = Peak.
- Trace mode = max hold.
- Sweep = auto couple.
- Measure the maximum width of the emission that is constrained by the frequencies associated with the two amplitude points (upper and lower) that are attenuated by 6 dB relative to the maximum level measured in the fundamental emission

4.3.5 Deviation from Test Standard

No deviation.

4.3.6 EUT Operating Conditions

The software provided by client to enable the EUT under transmission condition continuously at lowest, middle and highest channel frequencies individually.

4.3.7 Test Results

802.11b

Channel	Frequency (MHz)	6 dB Bandwidth (MHz)		Minimum Limit (MHz)	Pass / Fail
		Chain 0	Chain 1		
1	2412	7.08	7.09	0.5	Pass
6	2437	7.09	7.11	0.5	Pass
11	2462	7.06	7.09	0.5	Pass

802.11g

Channel	Frequency (MHz)	6 dB Bandwidth (MHz)		Minimum Limit (MHz)	Pass / Fail
		Chain 0	Chain 1		
1	2412	15.15	15.16	0.5	Pass
6	2437	15.14	15.17	0.5	Pass
11	2462	15.12	15.16	0.5	Pass

802.11n (HT20)

Channel	Frequency (MHz)	6 dB Bandwidth (MHz)		Minimum Limit (MHz)	Pass / Fail
		Chain 0	Chain 1		
1	2412	15.16	15.16	0.5	Pass
6	2437	15.14	15.14	0.5	Pass
11	2462	15.14	15.14	0.5	Pass

802.11n (HT40)

Channel	Frequency (MHz)	6 dB Bandwidth (MHz)		Minimum Limit (MHz)	Pass / Fail
		Chain 0	Chain 1		
3	2422	30.23	31.38	0.5	Pass
6	2437	32.62	35.13	0.5	Pass
9	2452	32.58	31.32	0.5	Pass

Spectrum Plot of Worst Value

802.11b

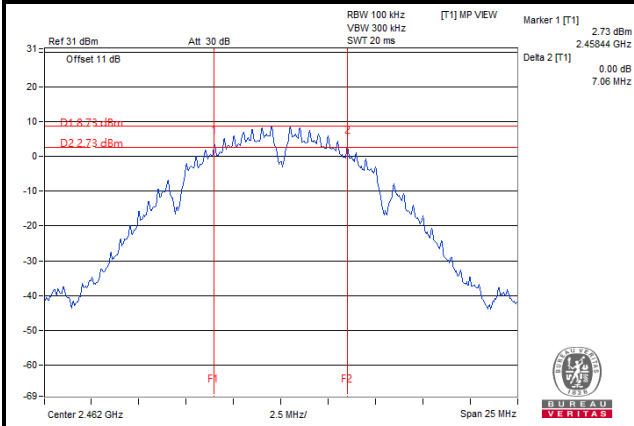

802.11g

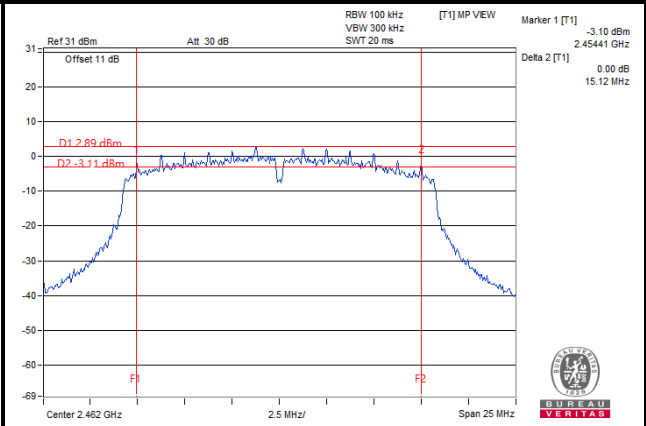

802.11n (HT20)

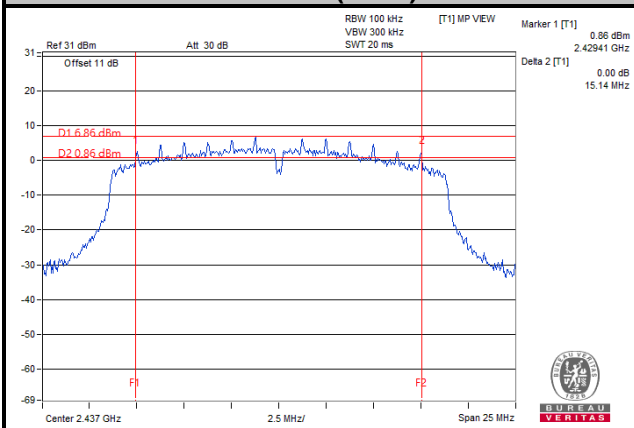

802.11n (HT40)

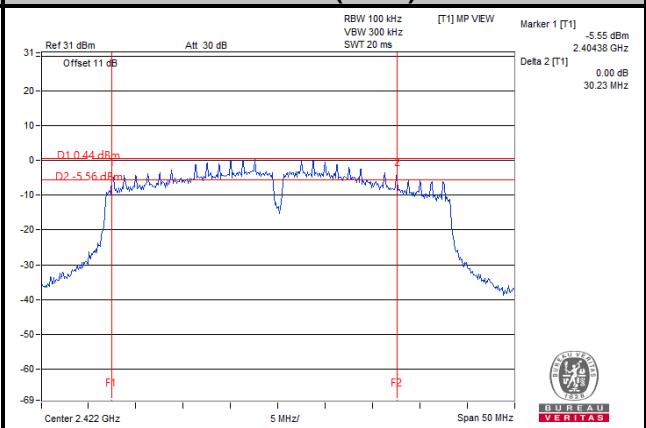

4.4 Occupied Bandwidth Measurement

4.4.1 Test Setup

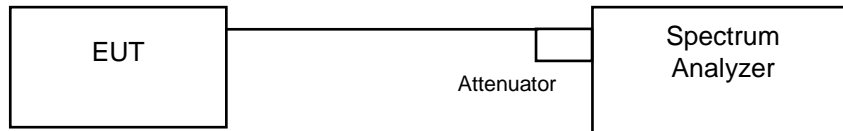

4.4.2 Test Instruments

Refer to section 4.1.2 to get information of above instrument.

4.4.3 Test Procedure

The transmitter output was connected to the spectrum analyzer through an attenuator. The bandwidth of the fundamental frequency was measured by spectrum analyzer with resolution bandwidth in the range of 1 % to 5 % of the anticipated emission bandwidth, and a video bandwidth at least 3x the resolution bandwidth and set the detector to sampling. The width of a frequency band such that, below the lower and above the upper frequency limits, the mean powers emitted are each equal to a specified percentage 0.5 % of the total mean power of a given emission.

4.4.4 Deviation from Test Standard

No deviation.

4.4.5 EUT Operating Conditions

The software provided by client to enable the EUT under transmission condition continuously at lowest, middle and highest channel frequencies individually.

4.4.6 Test Results

802.11b

Channel	Frequency (MHz)	Occupied Bandwidth (MHz)		Pass / Fail
		Chain 0	Chain 1	
1	2412	11.39	12.00	Pass
6	2437	11.40	11.88	Pass
11	2462	11.52	11.76	Pass

802.11g

Channel	Frequency (MHz)	Occupied Bandwidth (MHz)		Pass / Fail
		Chain 0	Chain 1	
1	2412	16.20	16.20	Pass
6	2437	16.20	16.26	Pass
11	2462	16.20	16.20	Pass

802.11n (HT20)

Channel	Frequency (MHz)	Occupied Bandwidth (MHz)		Pass / Fail
		Chain 0	Chain 1	
1	2412	17.40	17.40	Pass
6	2437	17.40	17.40	Pass
11	2462	17.31	17.40	Pass

802.11n (HT40)

Channel	Frequency (MHz)	Occupied Bandwidth (MHz)		Pass / Fail
		Chain 0	Chain 1	
3	2422	36.26	36.24	Pass
6	2437	36.12	36.00	Pass
9	2452	36.24	36.00	Pass

Spectrum Plot of Worst Value

802.11b

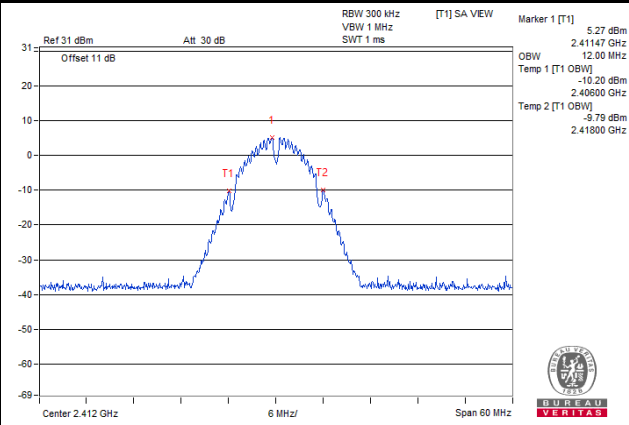

802.11g

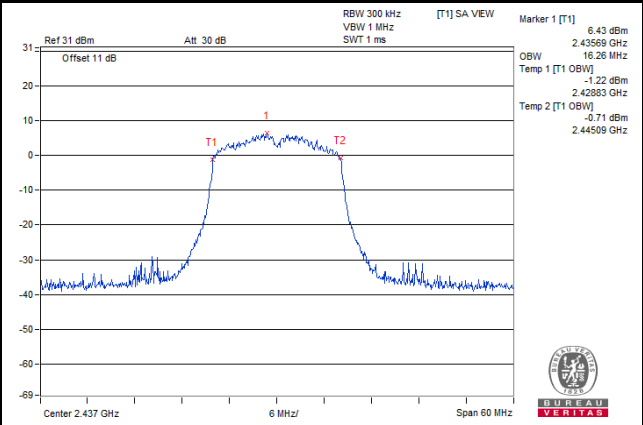

802.11n (HT20)

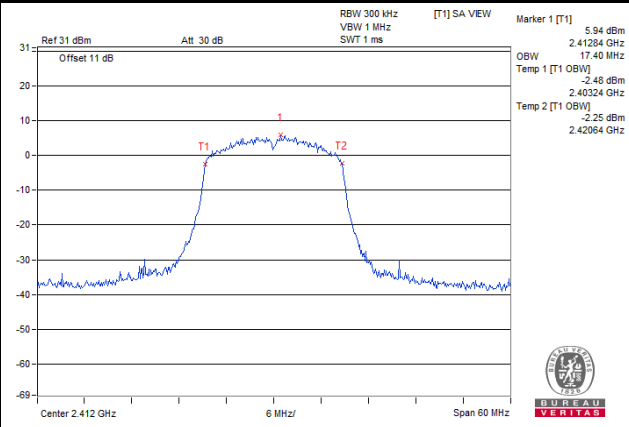

802.11n (HT40)

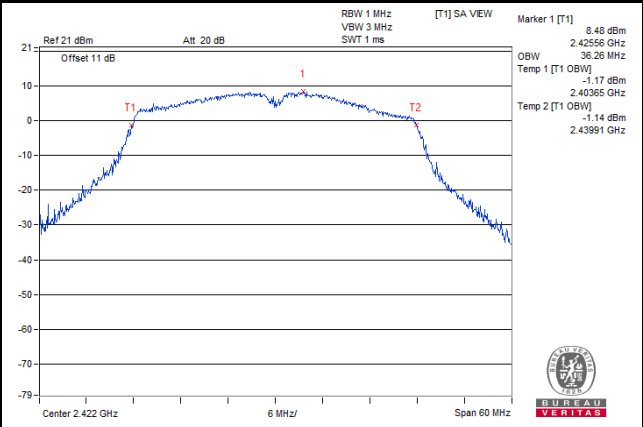

4.5 Conducted Output Power Measurement

4.5.1 Limits of Conducted Output Power Measurement

For systems using digital modulation in the 2400–2483.5 MHz bands: 1 Watt (30 dBm)

Per KDB 662911 D01 Multiple Transmitter Output Method of conducted output power measurement on IEEE 802.11 devices,

Array Gain = 0 dB (i.e., no array gain) for NANT \leq 4;

Array Gain = 0 dB (i.e., no array gain) for channel widths \geq 40 MHz for any NANT;

Array Gain = 5 log(NANT/NSS) dB or 3 dB, whichever is less for 20 MHz channel widths with NANT \geq 5.

For power measurements on all other devices: Array Gain = 10 log(NANT/NSS) dB.

4.5.2 Test Setup

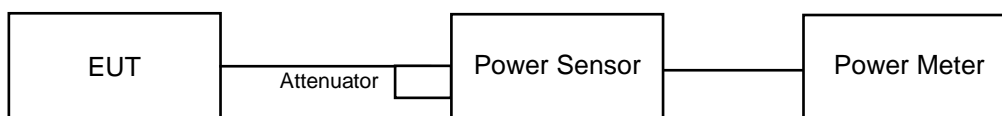

4.5.3 Test Instruments

Refer to section 4.1.2 to get information of above instrument.

4.5.4 Test Procedures

Average power sensor was used to perform output power measurement, trigger and gating function of wide band power meter is enabled to measure max output power of TX on burst. Duty factor is not added to measured value.

4.5.5 Deviation from Test Standard

No deviation.

4.5.6 EUT Operating Conditions

The software provided by client to enable the EUT under transmission condition continuously at lowest, middle and highest channel frequencies individually.

4.5.7 Test Results

CDD Mode
802.11b

Channel	Frequency (MHz)	Average Power (dBm)		Total Power (mW)	Total Power (dBm)	Limit (dBm)	Pass / Fail
		Chain 0	Chain 1				
1	2412	12.98	12.84	39.092	15.92	30	Pass
6	2437	14.65	14.59	57.948	17.63	30	Pass
11	2462	16.82	16.61	93.898	19.73	30	Pass

802.11g

Channel	Frequency (MHz)	Average Power (dBm)		Total Power (mW)	Total Power (dBm)	Limit (dBm)	Pass / Fail
		Chain 0	Chain 1				
1	2412	13.66	13.42	45.206	16.55	30	Pass
6	2437	14.18	13.99	51.243	17.10	30	Pass
11	2462	13.52	13.45	44.621	16.50	30	Pass

802.11n (HT20)

Channel	Frequency (MHz)	Average Power (dBm)		Total Power (mW)	Total Power (dBm)	Limit (dBm)	Pass / Fail
		Chain 0	Chain 1				
1	2412	13.81	13.73	47.648	16.78	30	Pass
6	2437	16.82	16.59	93.688	19.72	30	Pass
11	2462	13.93	13.36	46.394	16.66	30	Pass

802.11n (HT40)

Channel	Frequency (MHz)	Average Power (dBm)		Total Power (mW)	Total Power (dBm)	Limit (dBm)	Pass / Fail
		Chain 0	Chain 1				
3	2422	13.06	12.89	39.684	15.99	30	Pass
6	2437	15.53	15.10	68.087	18.33	30	Pass
9	2452	13.12	12.93	40.145	16.04	30	Pass

Beamforming Mode

802.11n (HT20)

Channel	Frequency (MHz)	Average Power (dBm)		Total Power (mW)	Total Power (dBm)	Limit (dBm)	Pass / Fail
		Chain 0	Chain 1				
1	2412	13.81	13.73	47.648	16.78	28.88	Pass
6	2437	16.82	16.59	93.688	19.72	28.88	Pass
11	2462	13.93	13.36	46.394	16.66	28.88	Pass

NOTE: Directional gain = 7.12 dBi > 6dBi, so the output power limit shall be reduced to $30 - (7.12 - 6) = 28.88$ dBm.

802.11n (HT40)

Channel	Frequency (MHz)	Average Power (dBm)		Total Power (mW)	Total Power (dBm)	Limit (dBm)	Pass / Fail
		Chain 0	Chain 1				
3	2422	13.06	12.89	39.684	15.99	28.88	Pass
6	2437	15.53	15.10	68.087	18.33	28.88	Pass
9	2452	13.12	12.93	40.145	16.04	28.88	Pass

NOTE: Directional gain = 7.12 dBi > 6dBi, so the output power limit shall be reduced to $30 - (7.12 - 6) = 28.88$ dBm.

4.6 Power Spectral Density Measurement

4.6.1 Limits of Power Spectral Density Measurement

The Maximum of Power Spectral Density Measurement is 8 dBm in any 3 kHz band during any time interval of continuous transmission.

4.6.2 Test Setup

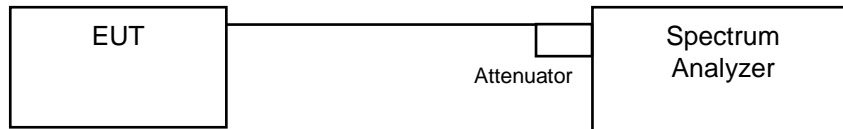

4.6.3 Test Instruments

Refer to section 4.1.2 to get information of above instrument.

4.6.4 Test Procedure

For Average Power (Duty cycle $\geq 98\%$)

- a. Set instrument center frequency to DTS channel center frequency.
- b. Set span to at least 1.5 times the OBW.
- c. Set RBW to: $3 \text{ kHz} \leq \text{RBW} \leq 100 \text{ kHz}$.
- d. Set VBW $\geq 3 \times \text{RBW}$.
- e. Detector = power averaging (RMS) or sample detector (when RMS not available).
- f. Ensure that the number of measurement points in the sweep $\geq 2 \times \text{span}/\text{RBW}$.
- g. Sweep time = auto couple.
- h. Employ trace averaging (RMS) mode over a minimum of 100 traces.
- i. Use the peak marker function to determine the maximum amplitude level.

For Average Power (Duty cycle $< 98\%$)

- a. Measure the duty cycle (x).
- b. Set instrument center frequency to DTS channel center frequency.
- c. Set span to at least 1.5 times the OBW.
- d. Set RBW to: $3 \text{ kHz} \leq \text{RBW} \leq 100 \text{ kHz}$.
- e. Set VBW $\geq 3 \times \text{RBW}$.
- f. Detector = power averaging (RMS) or sample detector (when RMS not available).
- g. Ensure that the number of measurement points in the sweep $\geq 2 \times \text{span}/\text{RBW}$.
- h. Sweep time = auto couple.
- i. Do not use sweep triggering. Allow sweep to "free run".
- j. Employ trace averaging (RMS) mode over a minimum of 100 traces.
- k. Use the peak marker function to determine the maximum amplitude level.
- l. Add $10 \log (1/x)$, where x is the duty cycle measured in step (a), to the measured PSD to compute the average PSD during the actual transmission time.

4.6.5 Deviation from Test Standard

No deviation.

4.6.6 EUT Operating Condition

The software provided by client to enable the EUT under transmission condition continuously at lowest, middle and highest channel frequencies individually.

4.6.7 Test Results

802.11b

TX Chain	Channel	Freq. (MHz)	PSD (dBm/3 kHz)	10 log (N=2) dB	Total PSD (dBm/3 kHz)	Limit (dBm/3 kHz)	Pass / Fail
0	1	2412	-19.83	3.01	-16.82	6.88	Pass
	6	2437	-18.48	3.01	-15.47	6.88	Pass
	11	2462	-16.1	3.01	-13.09	6.88	Pass
1	1	2412	-20.02	3.01	-17.01	6.88	Pass
	6	2437	-18.28	3.01	-15.27	6.88	Pass
	11	2462	-16.18	3.01	-13.17	6.88	Pass

NOTE:

- Method E) 2) c) of power density measurement of KDB 662911 is using for calculating total power density. Measure and add $10 \log (N_{ANT})$ dB.
- Directional gain = 7.12 dBi > 6dBi, so the power density limit shall be reduced to $8-(7.12-6) = 6.88\text{dBm}/3\text{kHz}$.

802.11g

TX Chain	Channel	Freq. (MHz)	PSD (dBm/3 kHz)	10 log (N=2) dB	Duty Factor (dB)	Total PSD (dBm/3 kHz)	Limit (dBm/3 kHz)	Pass / Fail
0	1	2412	-21.94	3.01	0.14	-18.79	6.88	Pass
	6	2437	-21.19	3.01	0.14	-18.04	6.88	Pass
	11	2462	-22.42	3.01	0.14	-19.27	6.88	Pass
1	1	2412	-21.48	3.01	0.14	-18.33	6.88	Pass
	6	2437	-21.33	3.01	0.14	-18.18	6.88	Pass
	11	2462	-21.45	3.01	0.14	-18.3	6.88	Pass

NOTE:

- Method E) 2) c) of power density measurement of KDB 662911 is using for calculating total power density. Measure and add $10 \log (N_{ANT})$ dB.
- Directional gain = 7.12 dBi > 6dBi, so the power density limit shall be reduced to $8-(7.12-6) = 6.88\text{dBm}/3\text{kHz}$.
- Refer to section 3.3 for duty cycle spectrum plot.

802.11n (HT20)

TX Chain	Channel	Freq. (MHz)	PSD (dBm/3 kHz)	10 log (N=2) dB	Duty Factor (dB)	Total PSD (dBm/3 kHz)	Limit (dBm/3 kHz)	Pass / Fail
0	1	2412	-22.18	3.01	0.14	-19.03	6.88	Pass
	6	2437	-18.49	3.01	0.14	-15.34	6.88	Pass
	11	2462	-21.84	3.01	0.14	-18.69	6.88	Pass
1	1	2412	-21.71	3.01	0.14	-18.56	6.88	Pass
	6	2437	-18.78	3.01	0.14	-15.63	6.88	Pass
	11	2462	-22.05	3.01	0.14	-18.9	6.88	Pass

NOTE:

- Method E) 2) c) of power density measurement of KDB 662911 is using for calculating total power density. Measure and add $10 \log (N_{ANT})$ dB.
- Directional gain = 7.12 dBi > 6dBi, so the power density limit shall be reduced to $8-(7.12-6) = 6.88\text{dBm}/3\text{kHz}$.
- Refer to section 3.3 for duty cycle spectrum plot.

802.11n (HT40)

TX Chain	Channel	Freq. (MHz)	PSD (dBm/3 kHz)	10 log (N=2) dB	Duty Factor (dB)	Total PSD (dBm/3 kHz)	Limit (dBm/3 kHz)	Pass / Fail
0	3	2422	-25.52	3.01	0.18	-22.33	6.88	Pass
	6	2437	-22.24	3.01	0.18	-19.05	6.88	Pass
	9	2452	-25.12	3.01	0.18	-21.93	6.88	Pass
1	3	2422	-25.11	3.01	0.18	-21.92	6.88	Pass
	6	2437	-23.53	3.01	0.18	-20.34	6.88	Pass
	9	2452	-25.56	3.01	0.18	-22.37	6.88	Pass

NOTE:

- Method E) 2) c) of power density measurement of KDB 662911 is using for calculating total power density. Measure and add $10 \log (N_{ANT})$ dB.
- Directional gain = 7.12 dBi > 6dBi, so the power density limit shall be reduced to $8-(7.12-6) = 6.88\text{dBm}/3\text{kHz}$.
- Refer to section 3.3 for duty cycle spectrum plot.

Spectrum Plot of Worst Value

802.11b

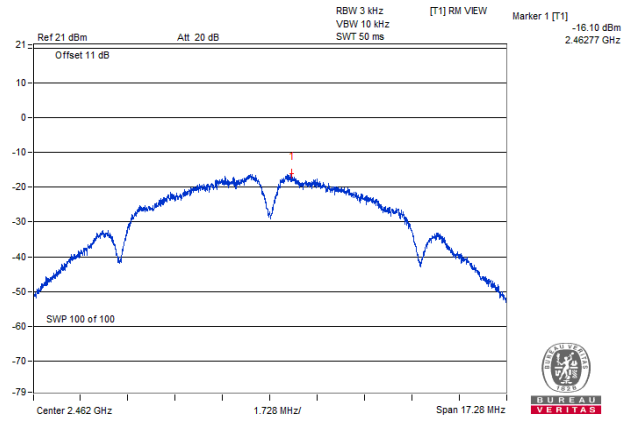

802.11g

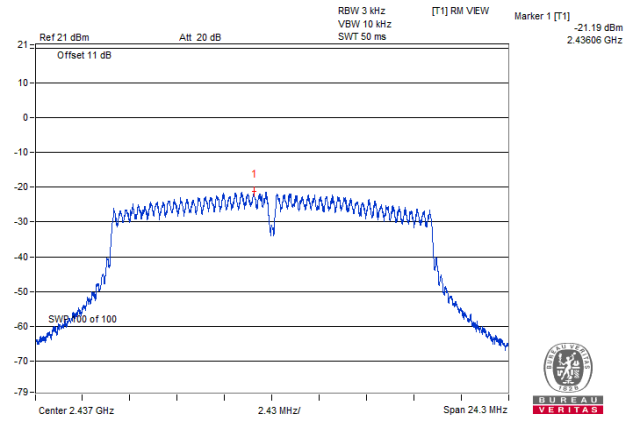

802.11n (HT20)

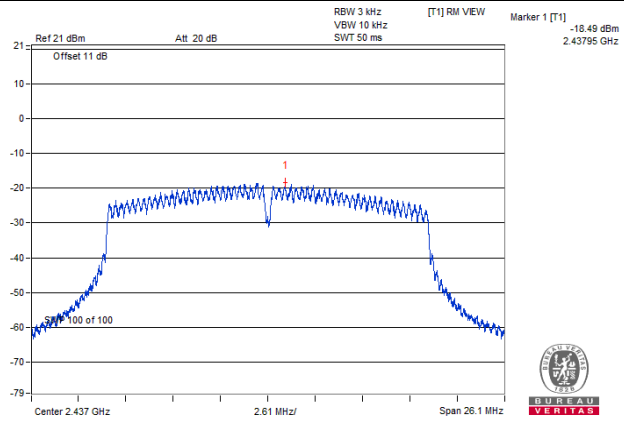

802.11n (HT40)

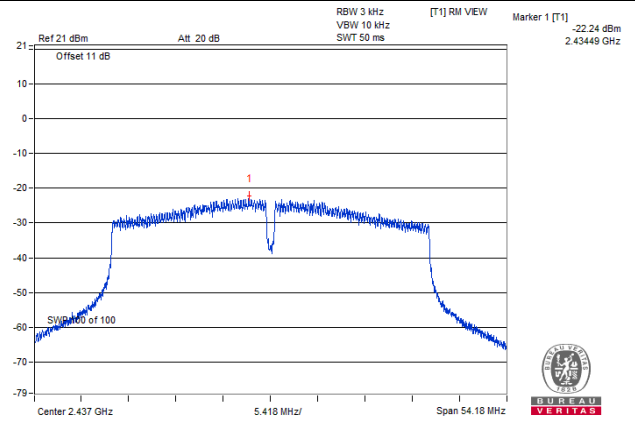

4.7 Conducted Out of Band Emission Measurement

4.7.1 Limits of Conducted Out of Band Emission Measurement

Below -30 dB of the highest emission level of operating band (in 100 kHz Resolution Bandwidth).

4.7.2 Test Setup

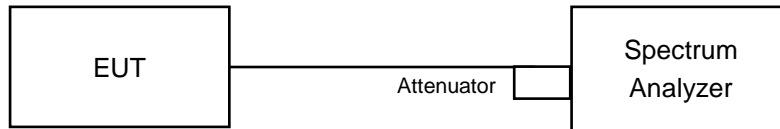

4.7.3 Test Instruments

Refer to section 4.1.2 to get information of above instrument.

4.7.4 Test Procedure

MEASUREMENT PROCEDURE REF

1. Set the RBW = 100 kHz.
2. Set the VBW \geq 300 kHz.
3. Detector = peak.
4. Sweep time = auto couple.
5. Trace mode = max hold.
6. Allow trace to fully stabilize.
7. Use the peak marker function to determine the maximum power level in any 100 kHz band segment within the fundamental EBW.

MEASUREMENT PROCEDURE OOB

1. Set RBW = 100 kHz.
2. Set VBW \geq 300 kHz.
3. Detector = peak.
4. Sweep = auto couple.
5. Trace Mode = max hold.
6. Allow trace to fully stabilize.
7. Use the peak marker function to determine the maximum amplitude level.

4.7.5 Deviation from Test Standard

No deviation.

4.7.6 EUT Operating Condition

The software provided by client to enable the EUT under transmission condition continuously at lowest, middle and highest channel frequencies individually.

4.7.7 Test Results

The conducted emission test is performed on each TX port of operating mode without summing or adding $10\log(N)$ since the limit is relative emission limit.

The spectrum plots are attached on the following images. D1 line indicates the highest level, and D2 line indicates the 30 dB offset below D1. It shows compliance with the requirement.

802.11b
CHAIN 0

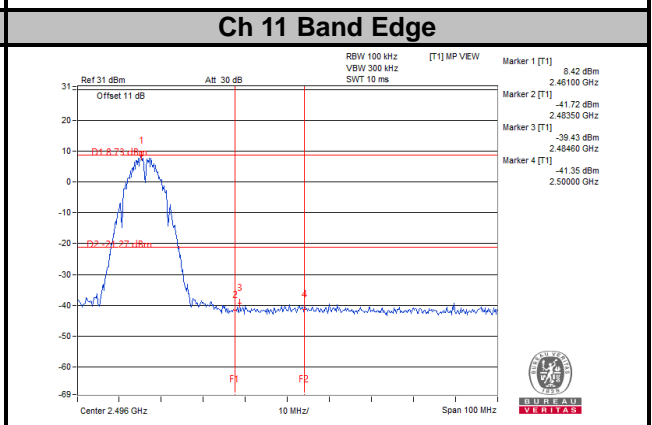
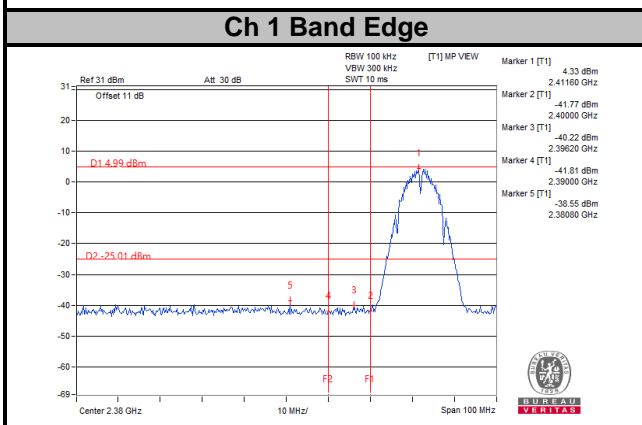
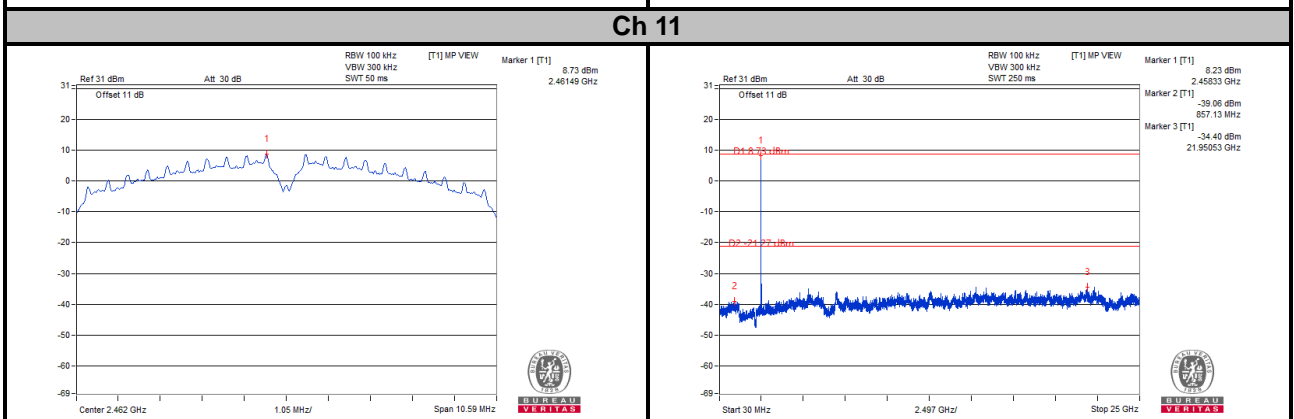
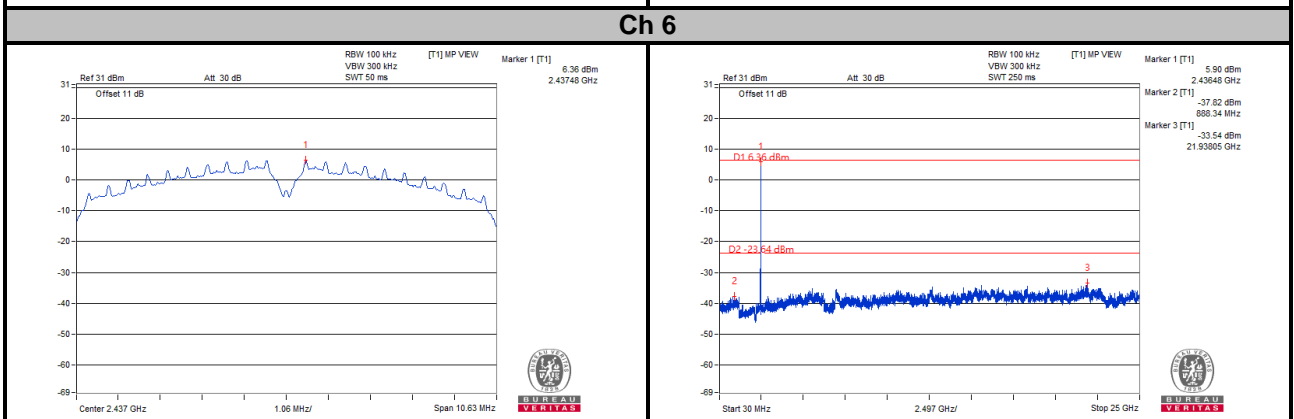
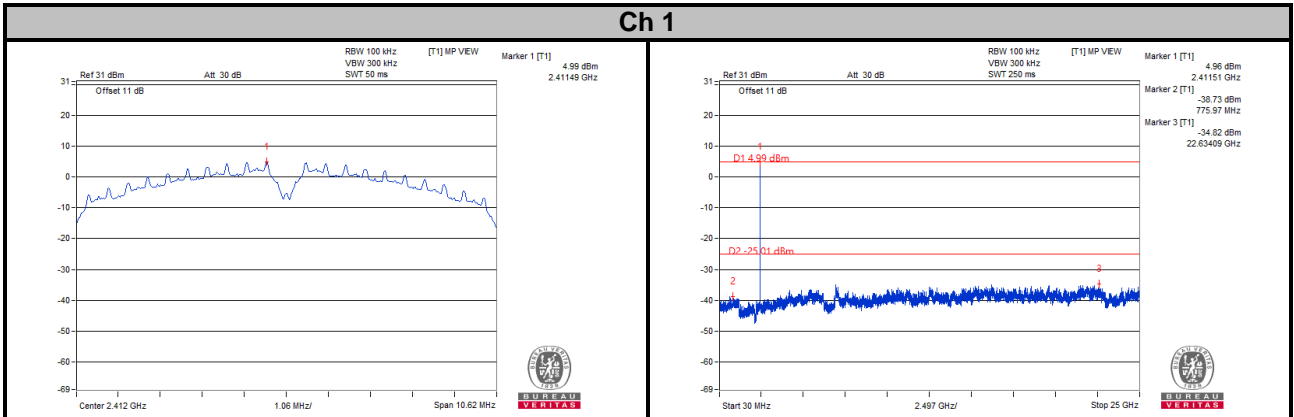

CHAIN 1

Ch 1

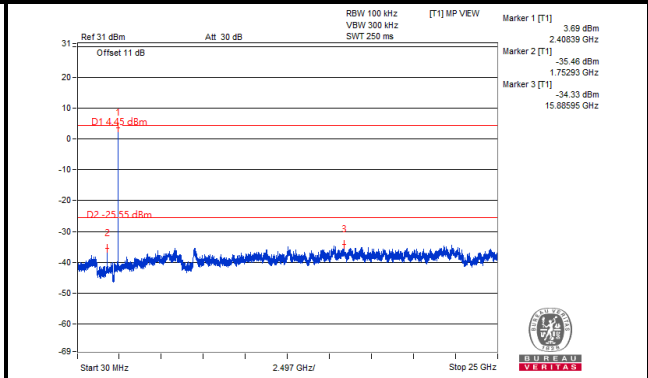
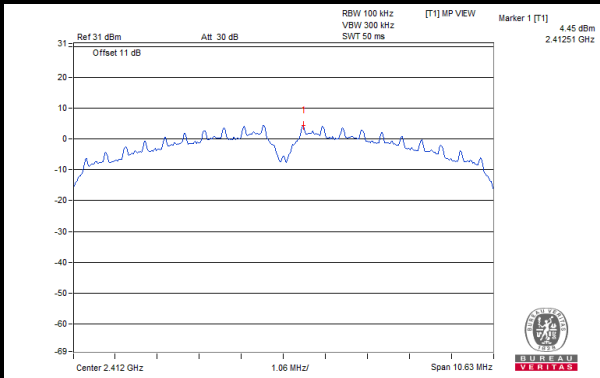

Ch 6

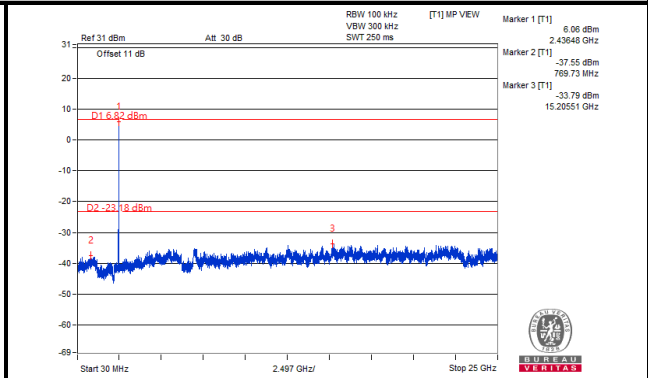
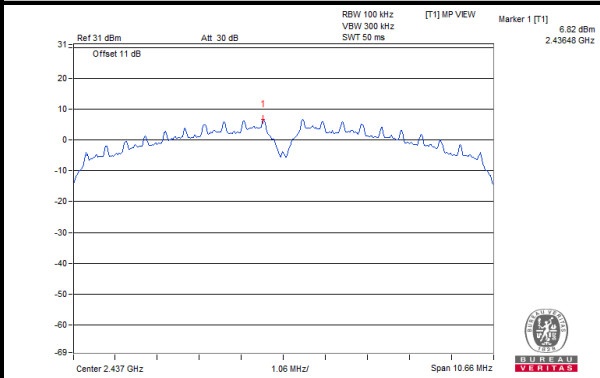

Ch 11

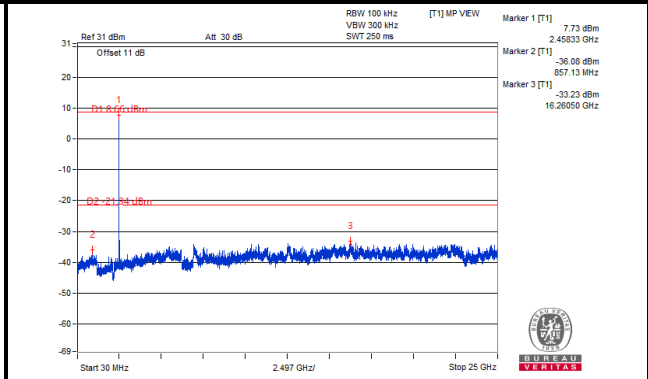
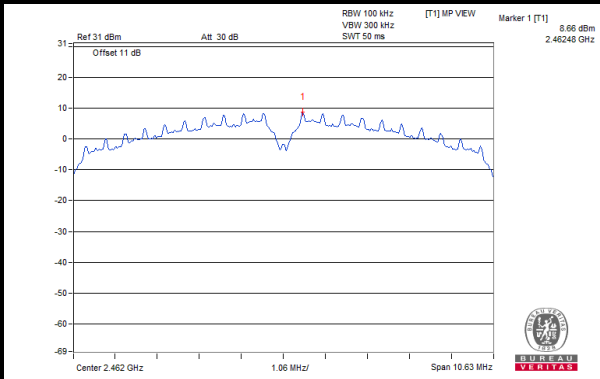

Ch 1 Band Edge

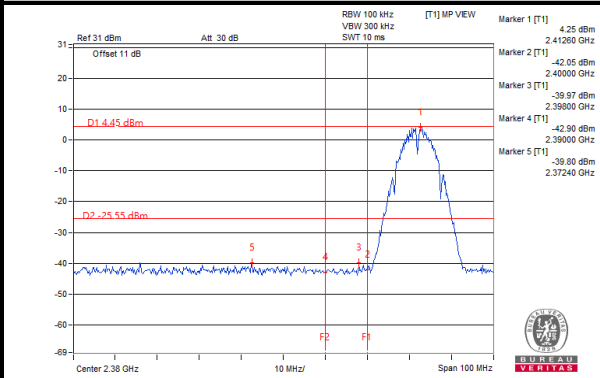

Ch 11 Band Edge

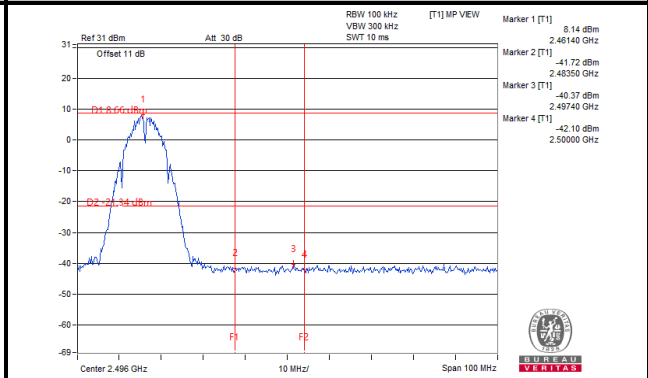

802.11g
CHAIN 0

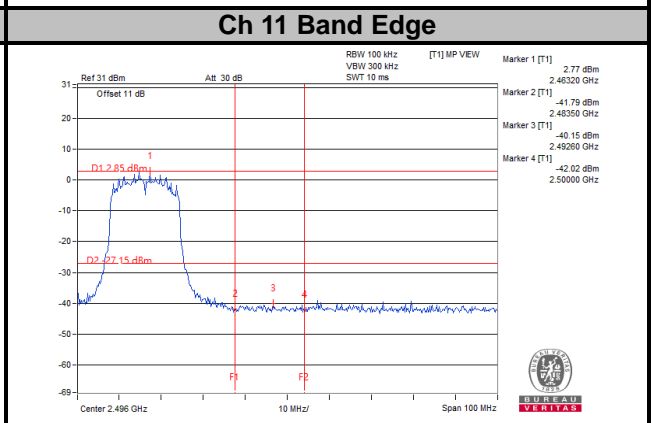
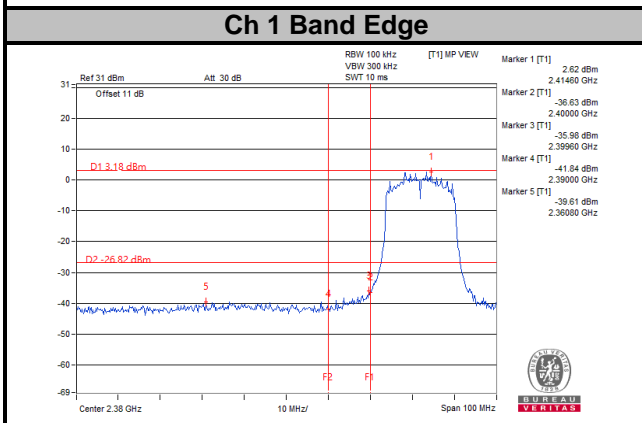
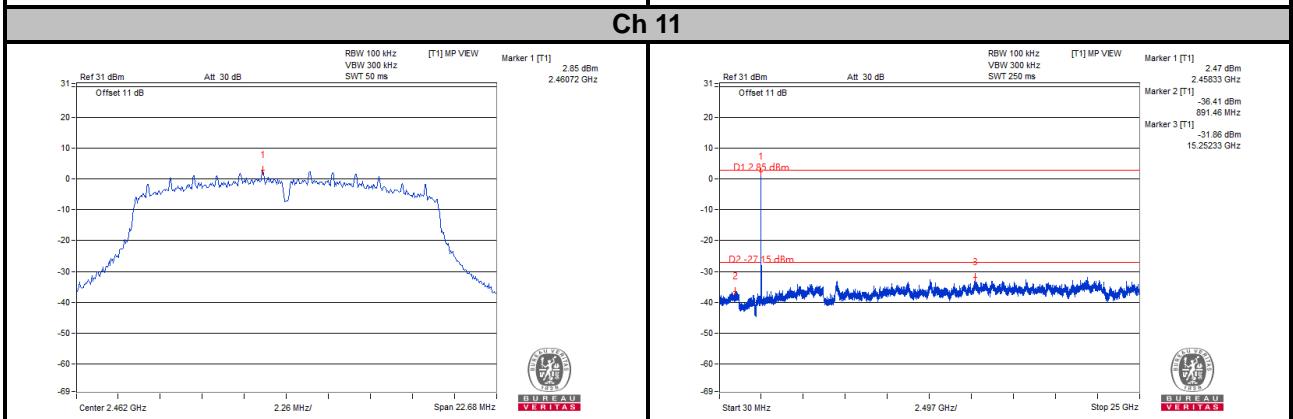
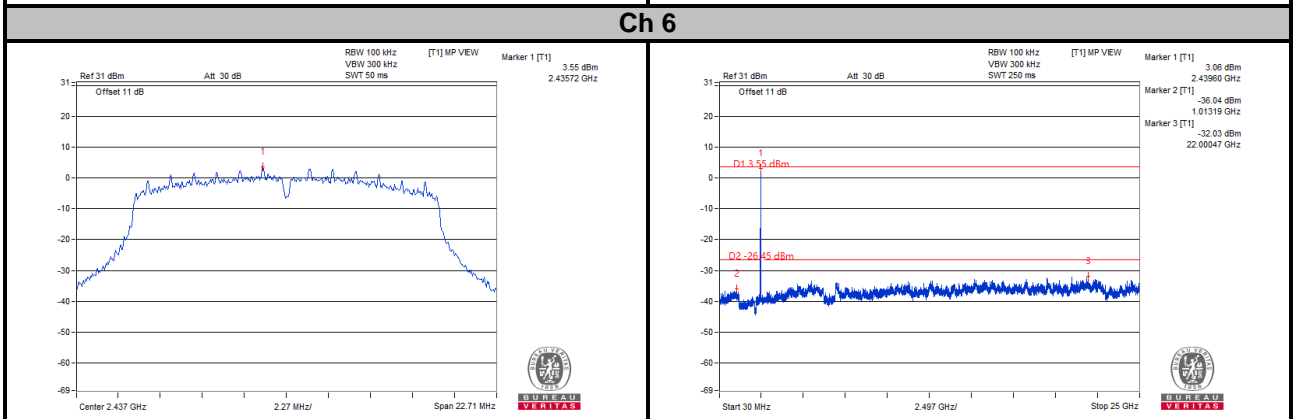
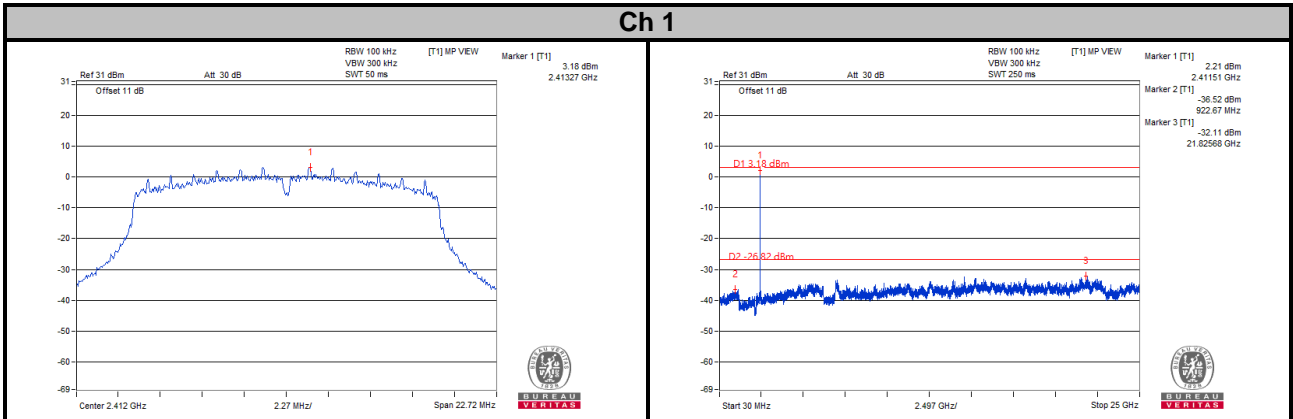

CHAIN 1

Ch 1

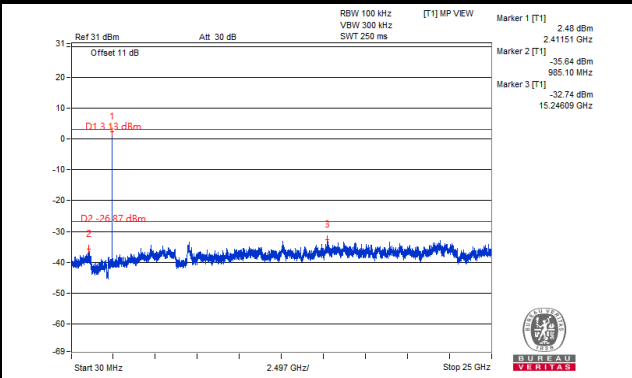
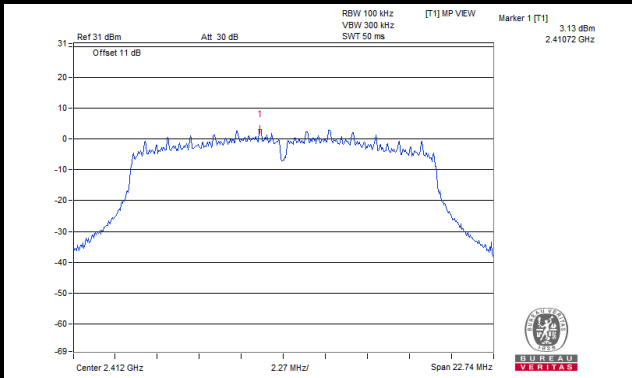

Ch 6

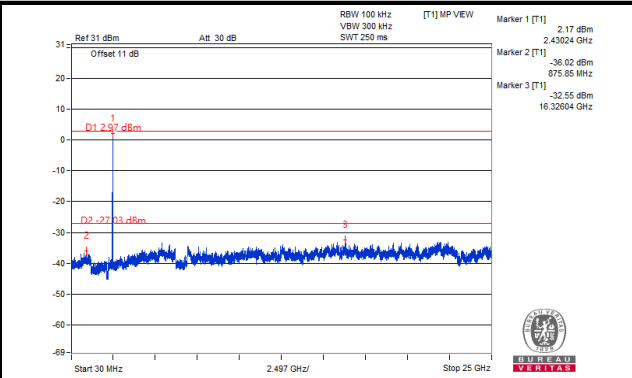
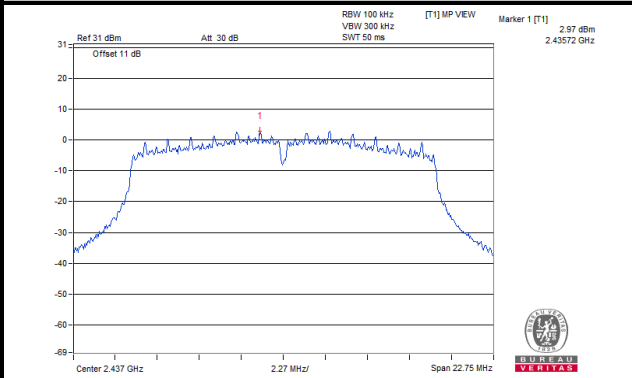

Ch 11

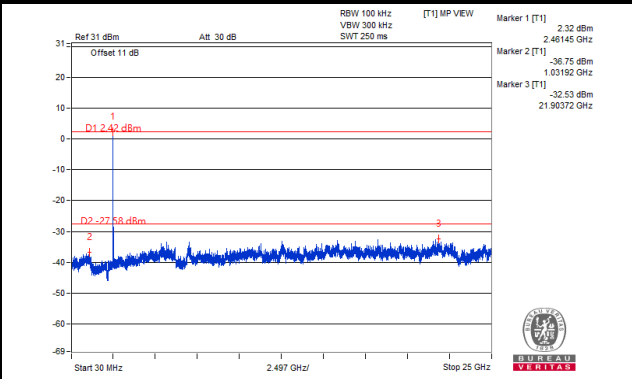
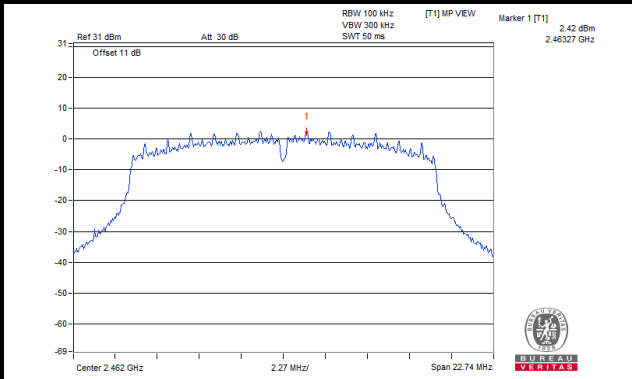

Ch 1 Band Edge

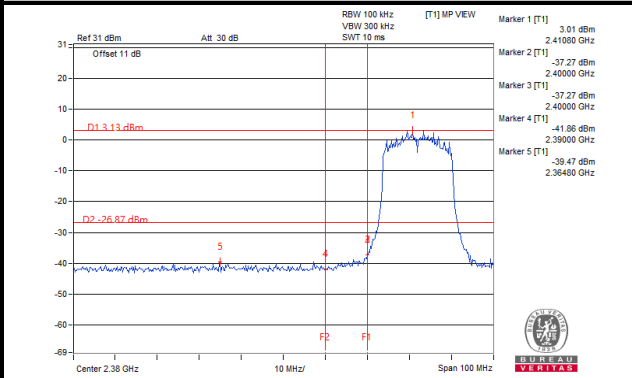

Ch 11 Band Edge

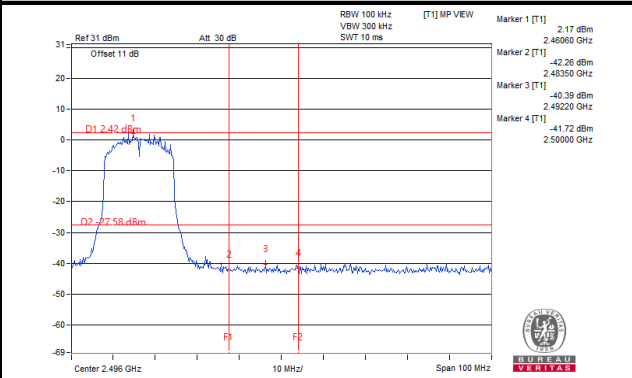

802.11n (HT20)
CHAIN 0

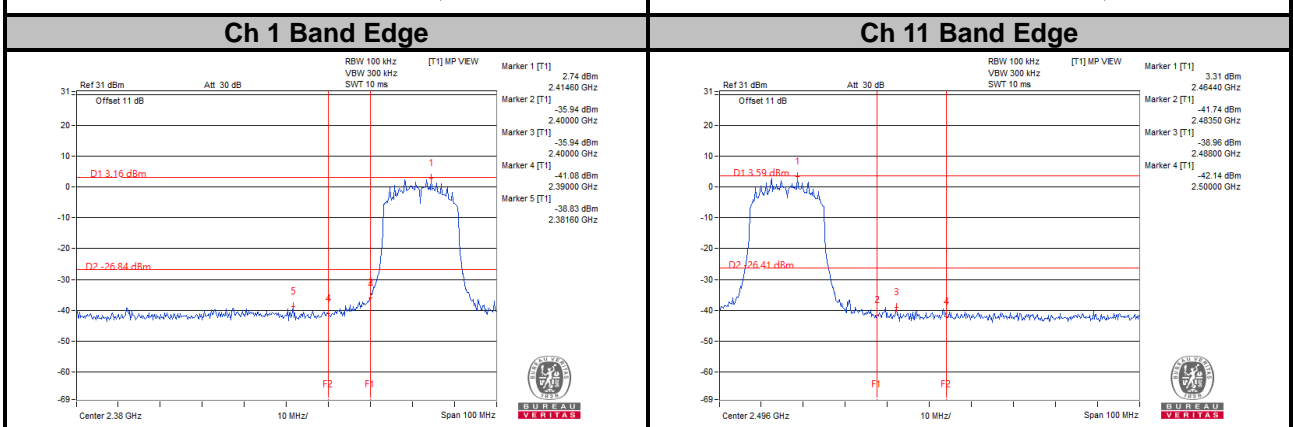
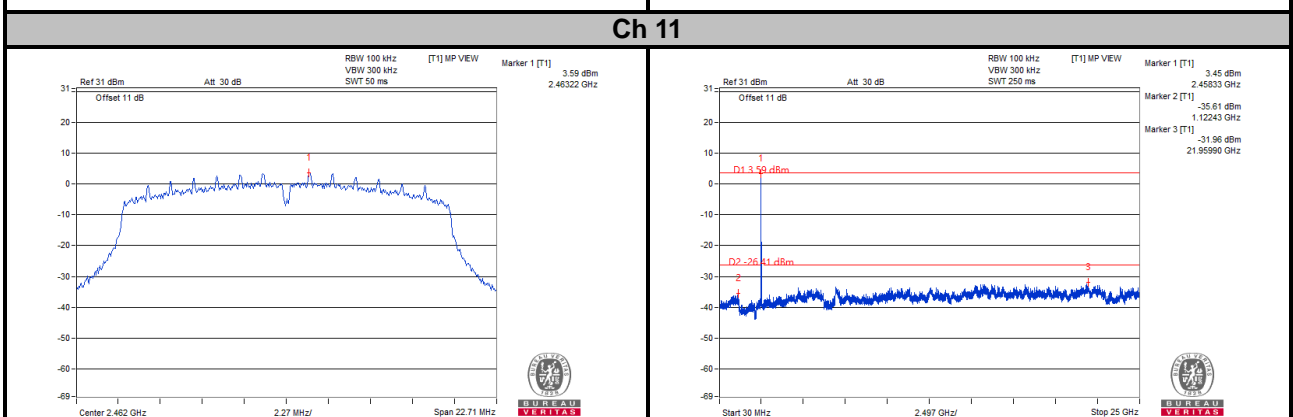
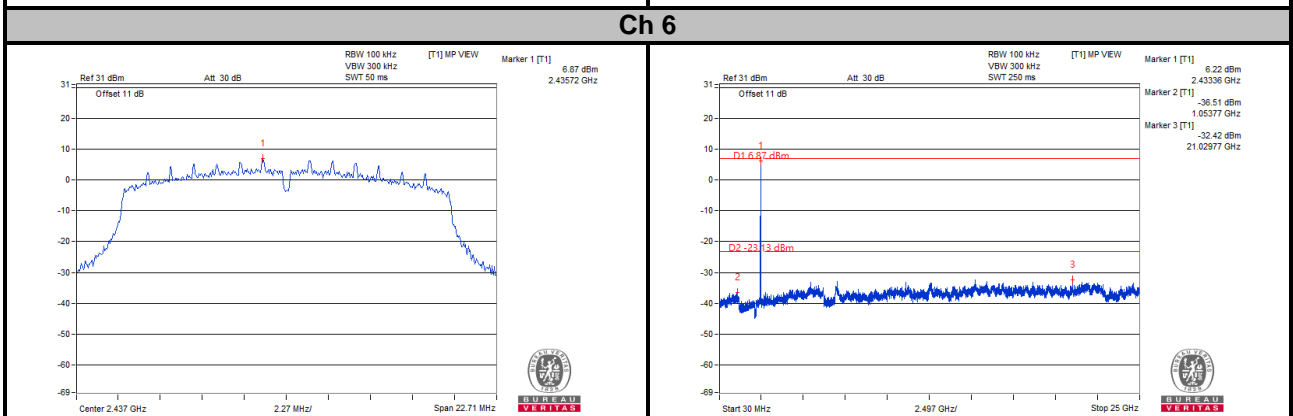
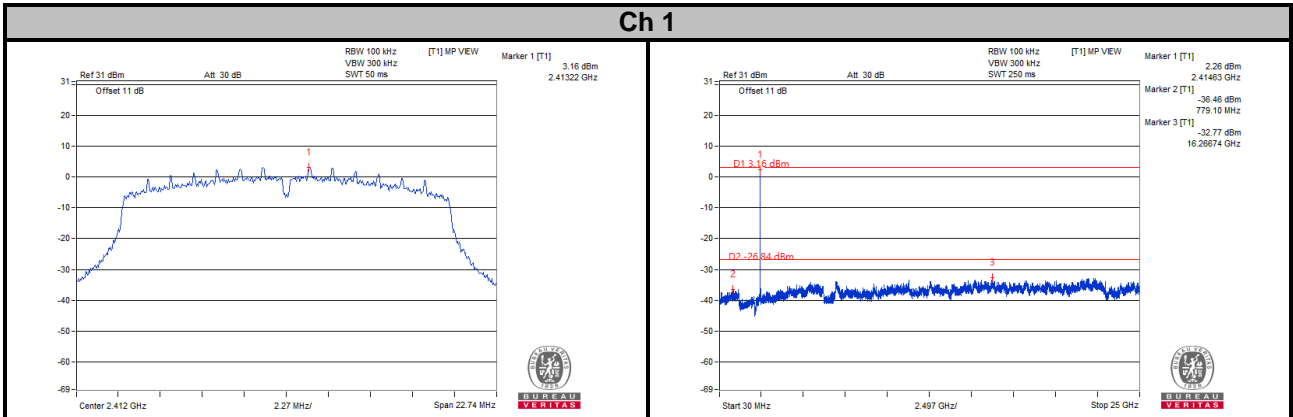

CHAIN 1

Ch 1

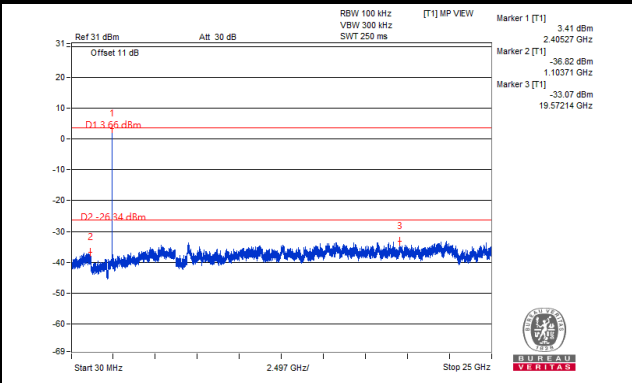
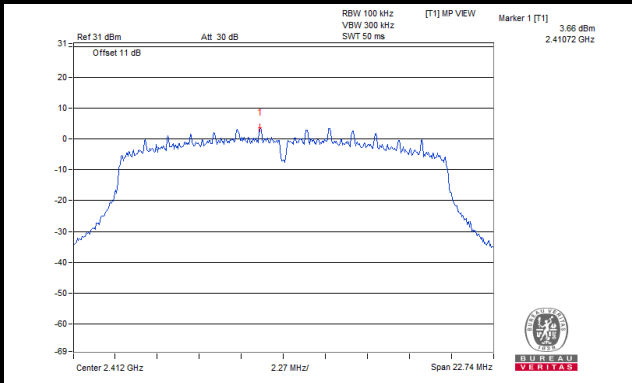

Ch 6

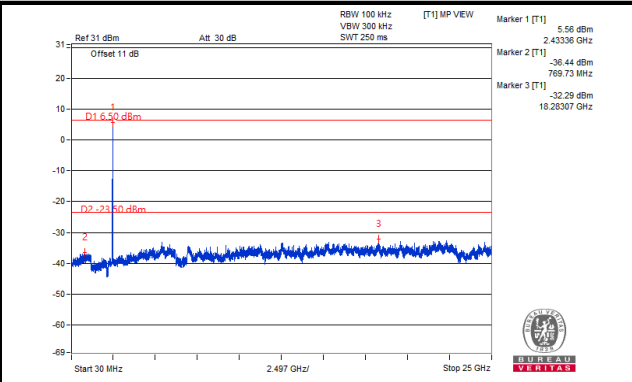
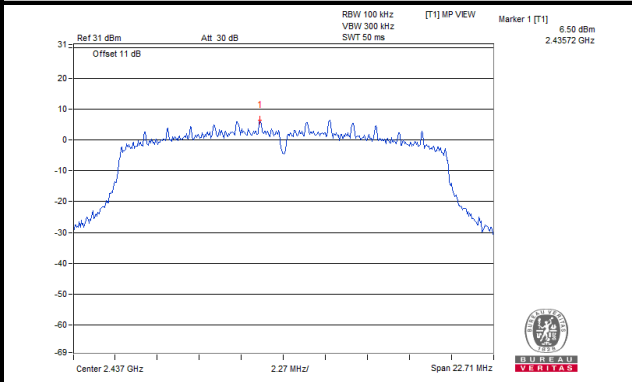

Ch 11

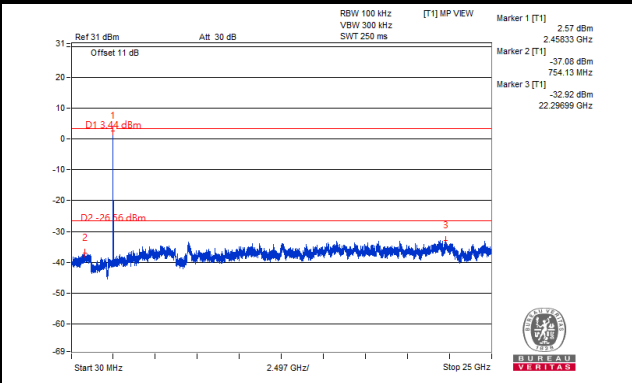
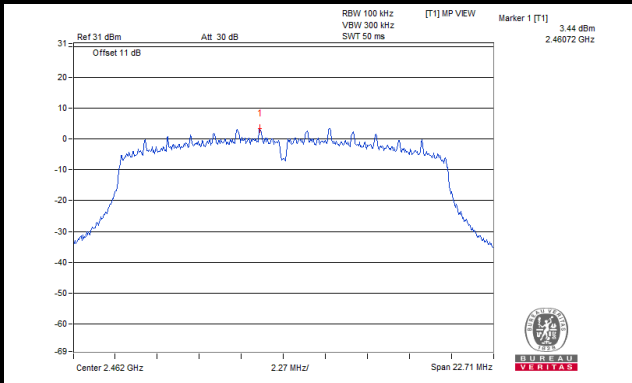

Ch 1 Band Edge

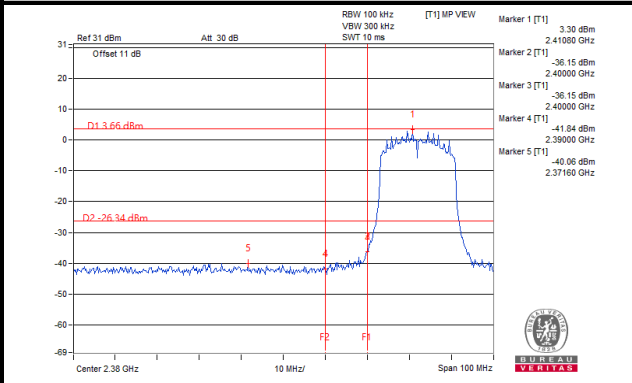

Ch 11 Band Edge

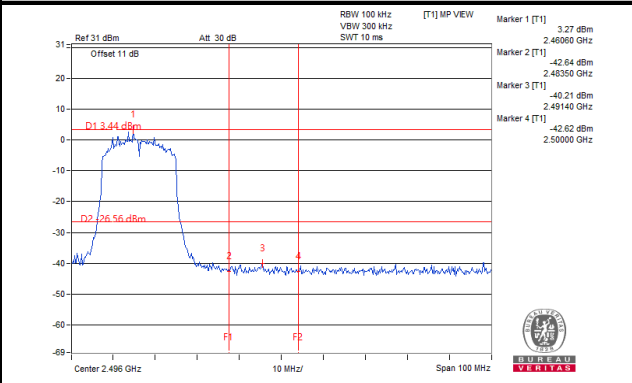

802.11n (HT40)
CHAIN 0

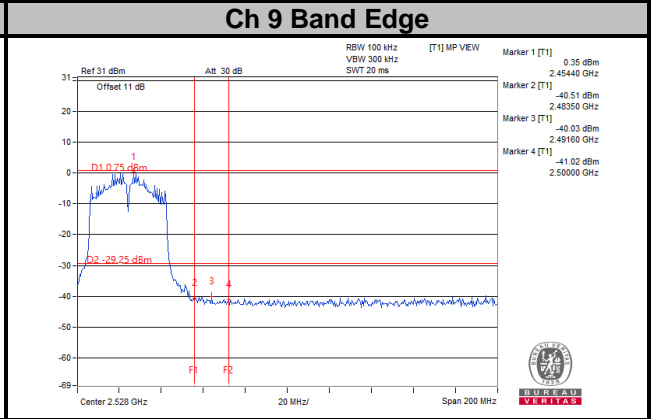
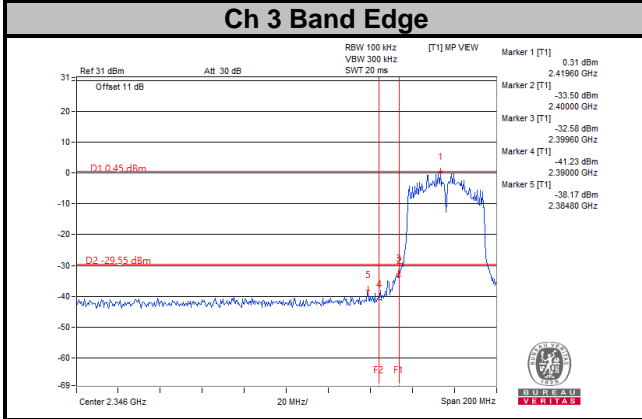
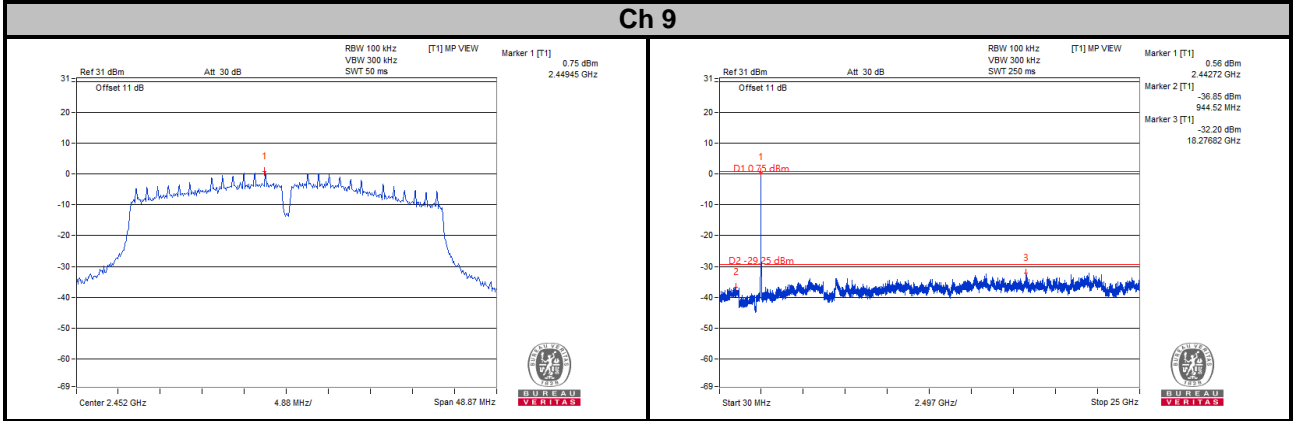
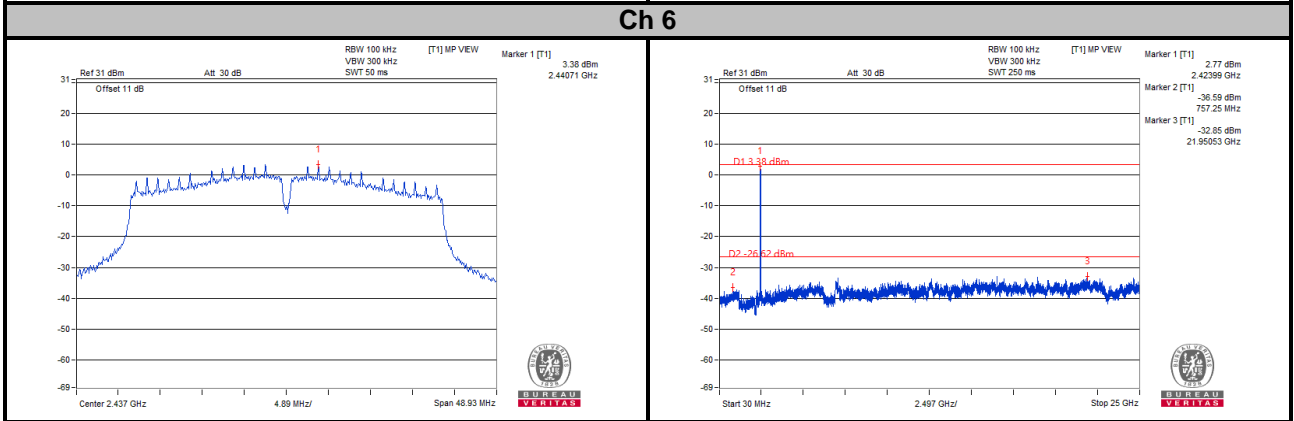
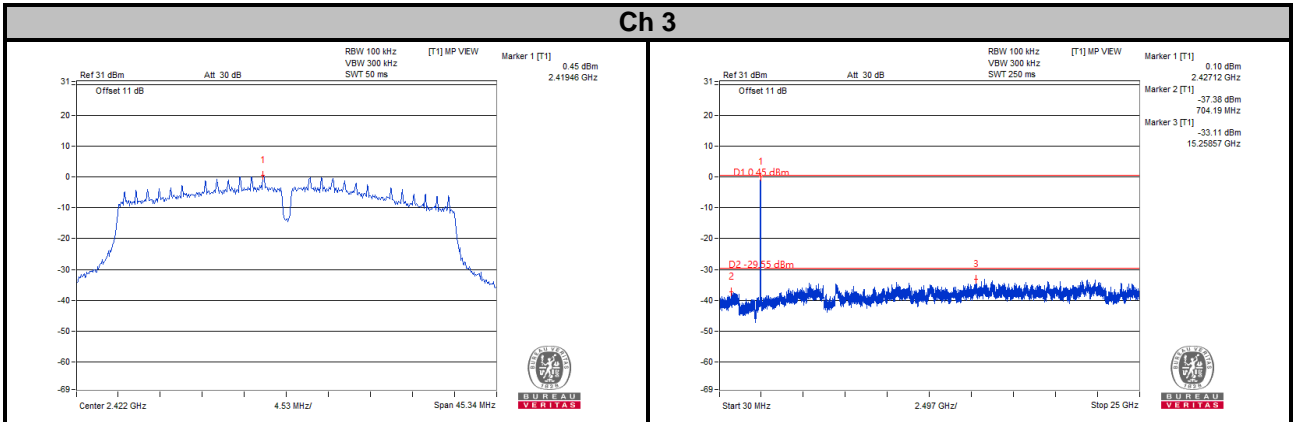

CHAIN 1

Ch 3

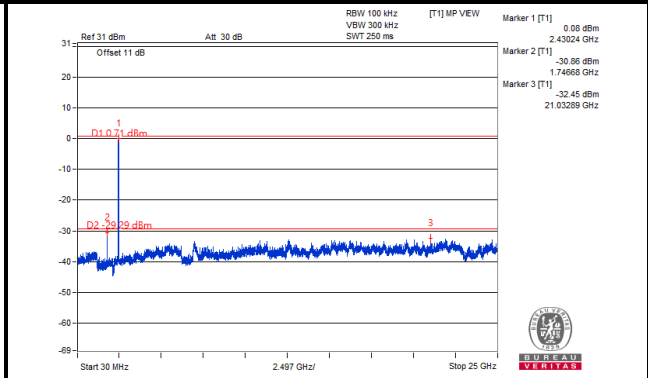
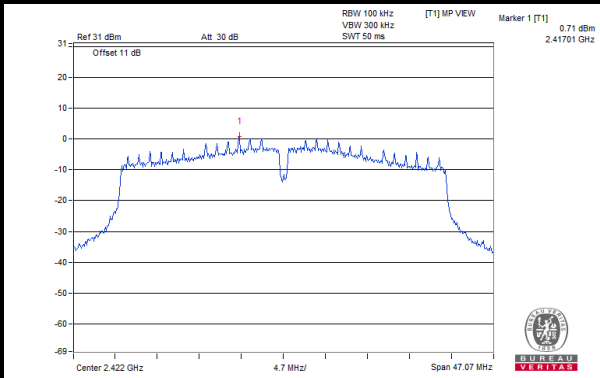

Ch 6

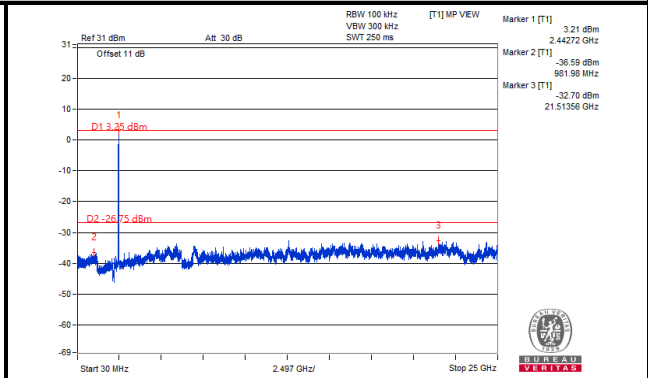
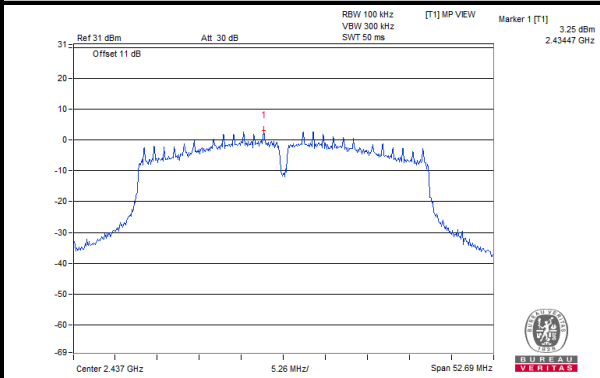

Ch 9

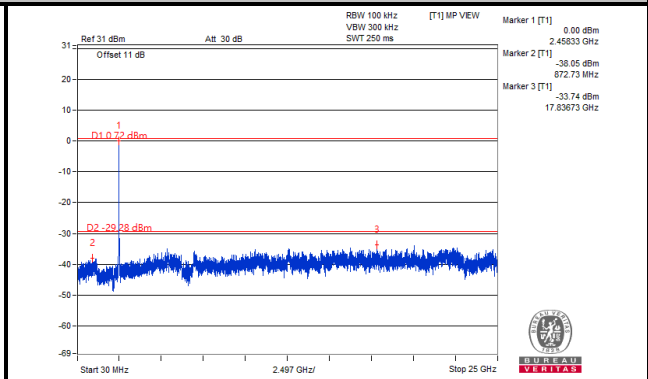
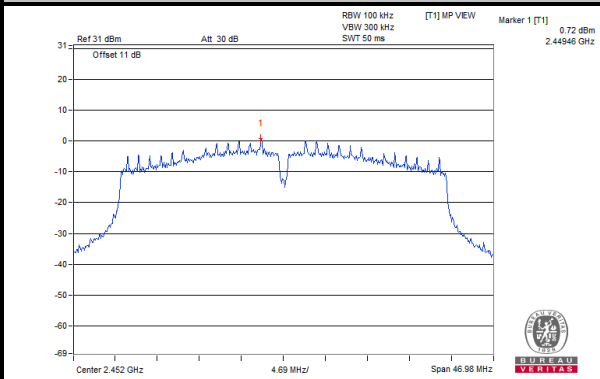

Ch 3 Band Edge

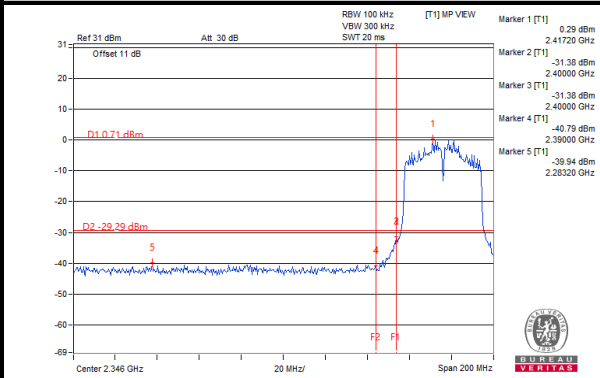

Ch 9 Band Edge

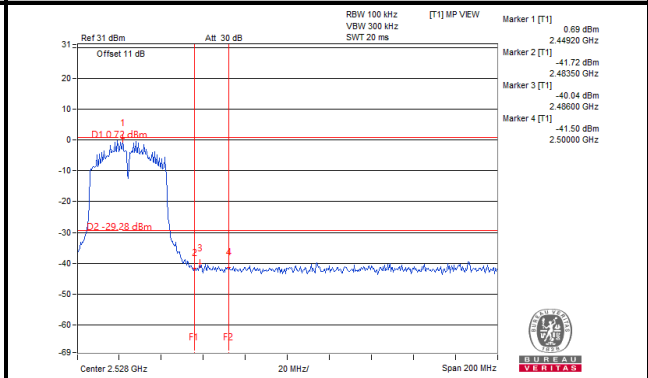

5 Pictures of Test Arrangements

Please refer to the attached file (Test Setup Photo).

Annex A- Band-edge measurement

802.11b

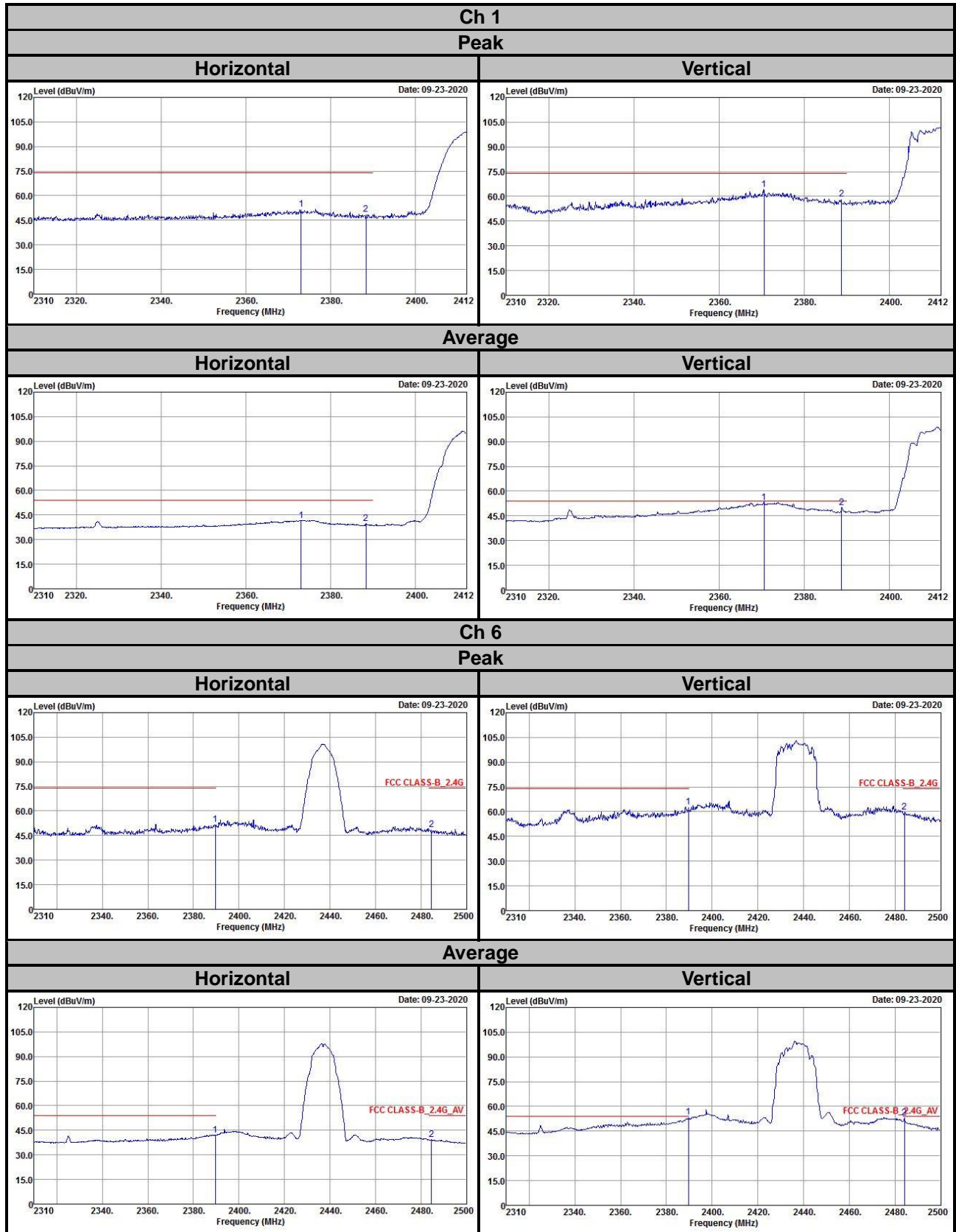

Ch 11

Peak

Horizontal

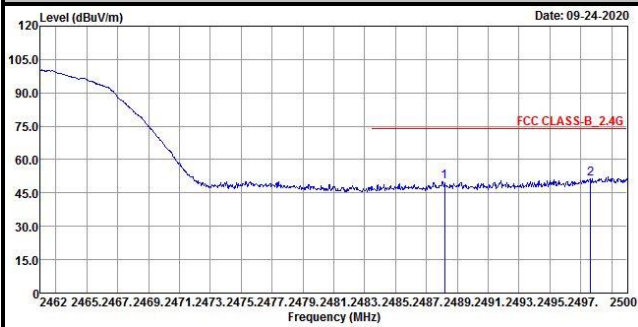

Vertical

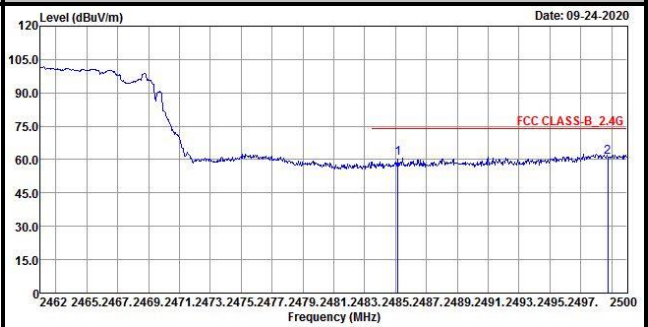

Average

Horizontal

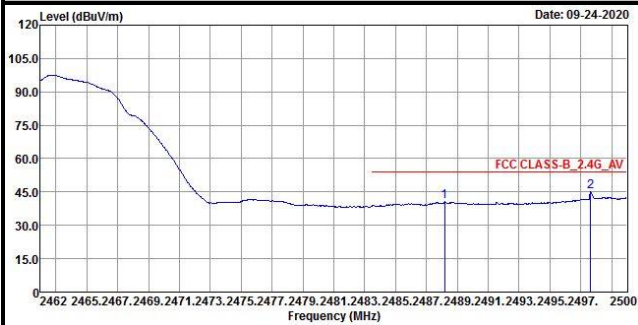

Vertical

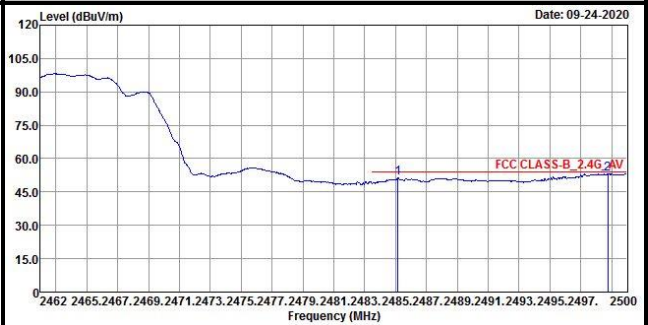

802.11g

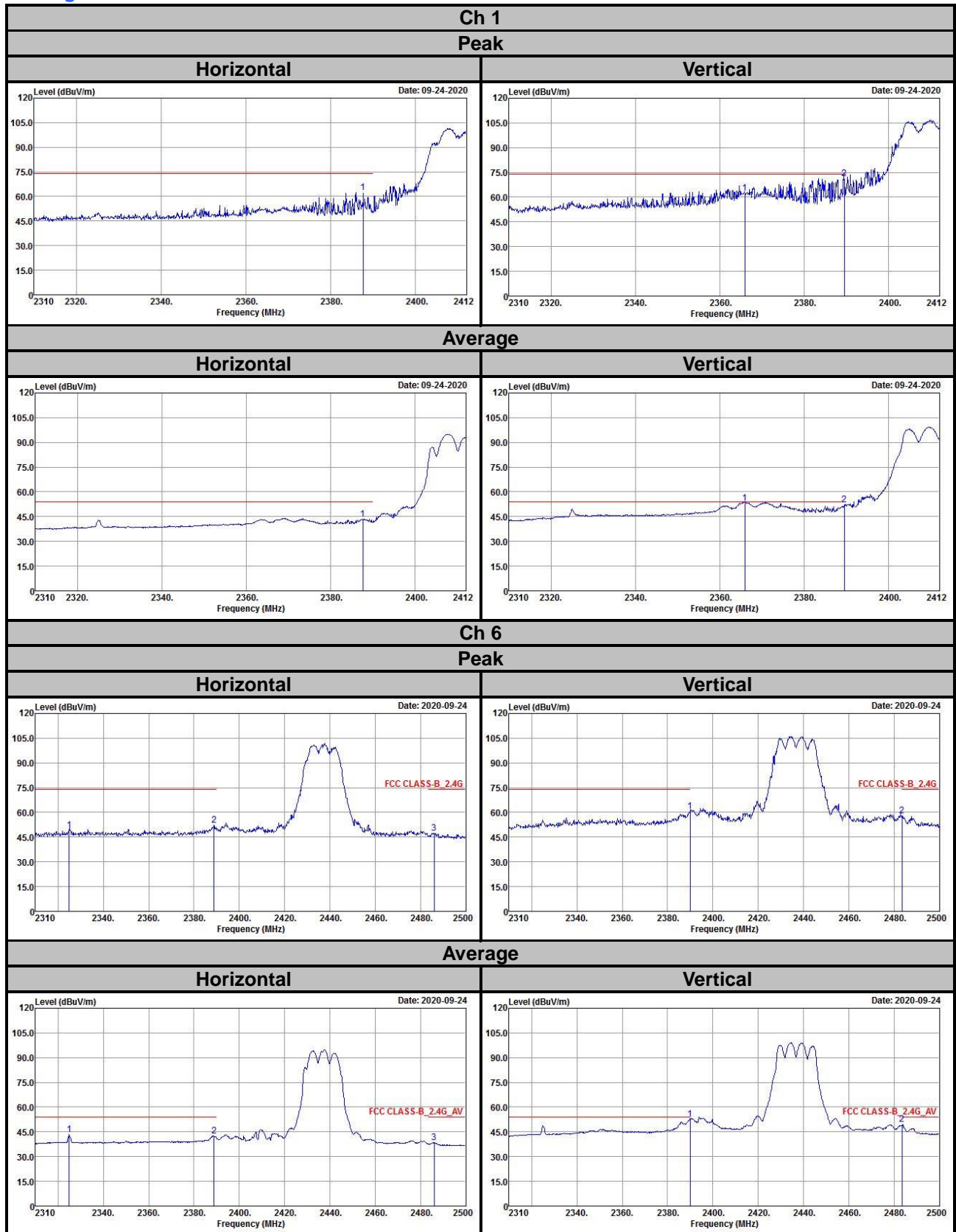

Ch 11

Peak

Horizontal

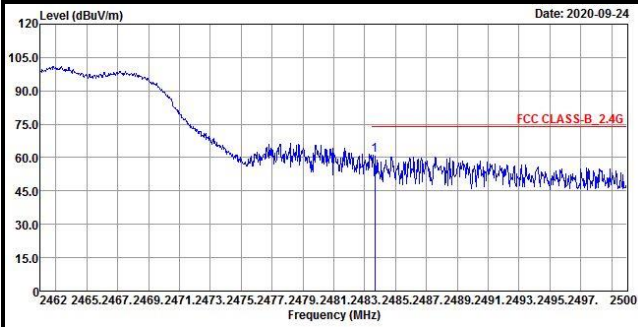

Vertical

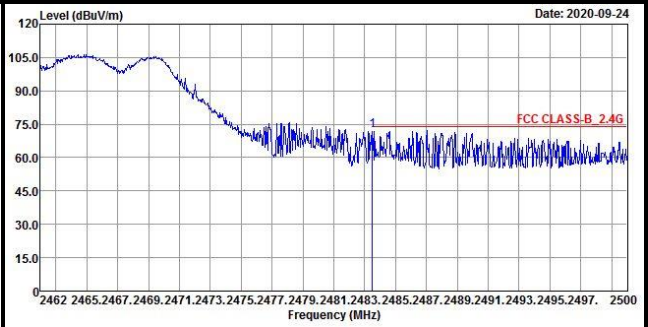

Average

Horizontal

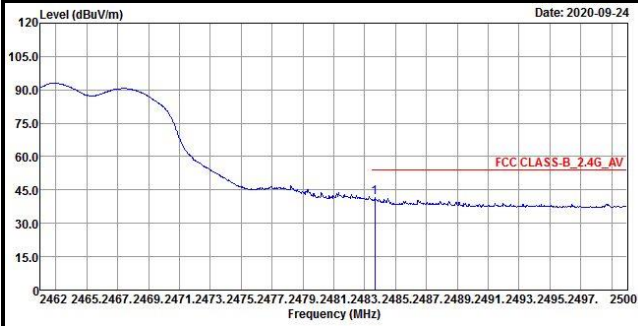

Vertical

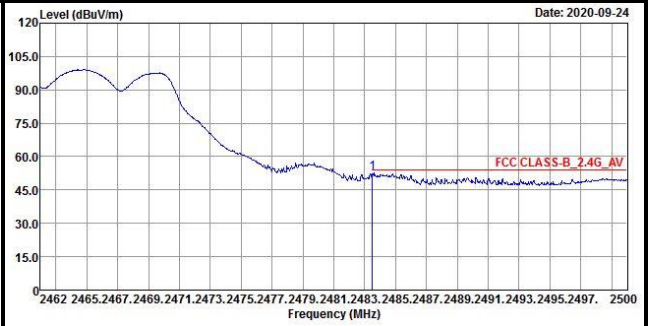

802.11n (HT20)

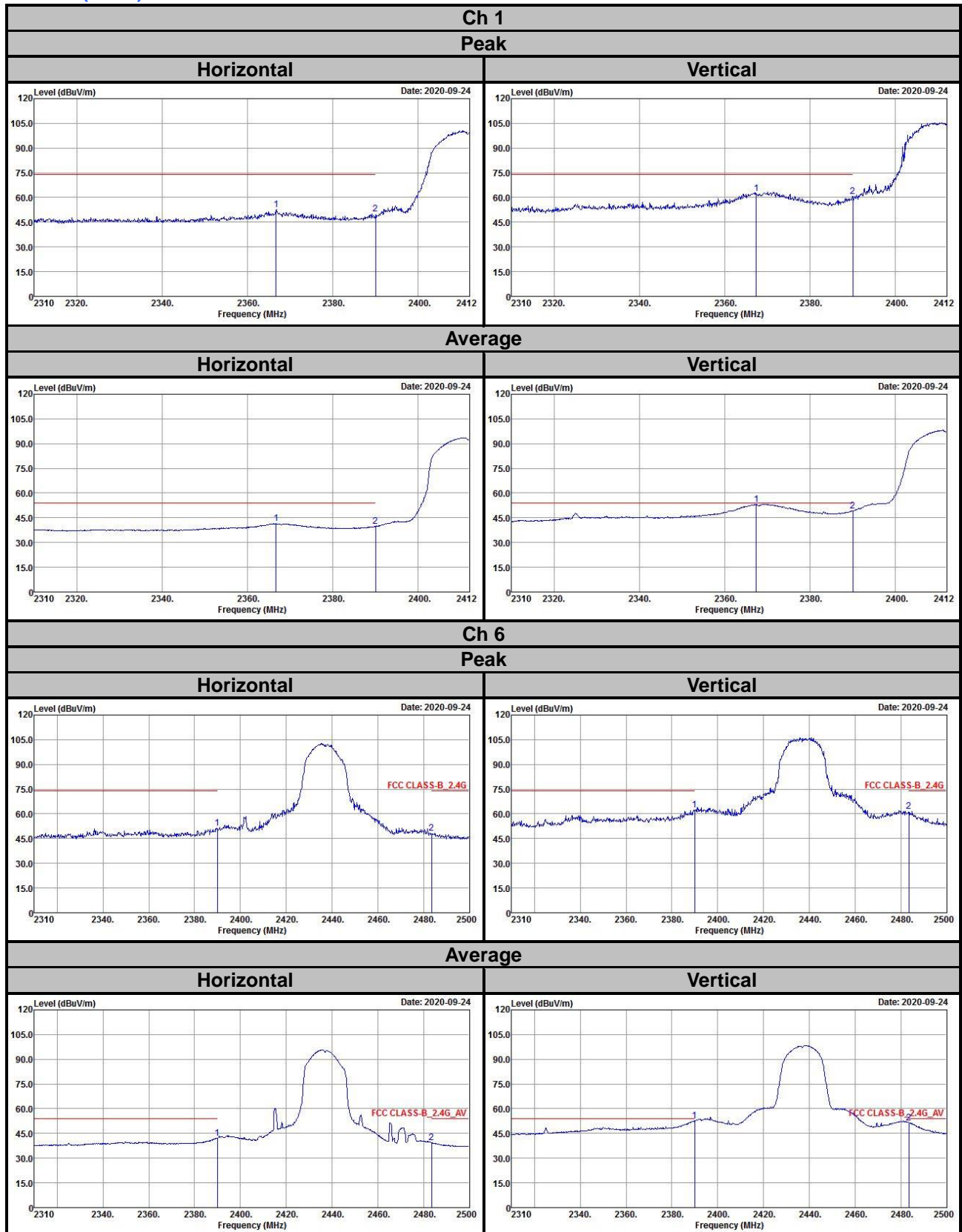

Ch 11

Peak

Horizontal

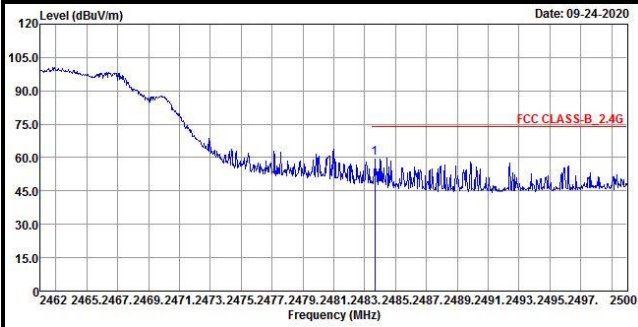

Vertical

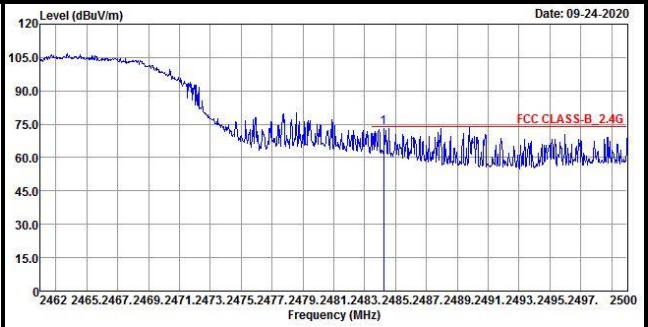

Average

Horizontal

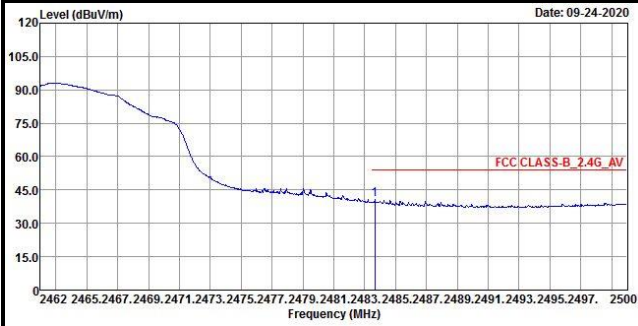

Vertical

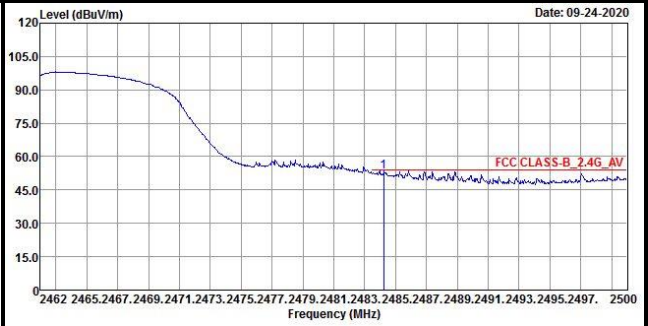

802.11n (HT40)

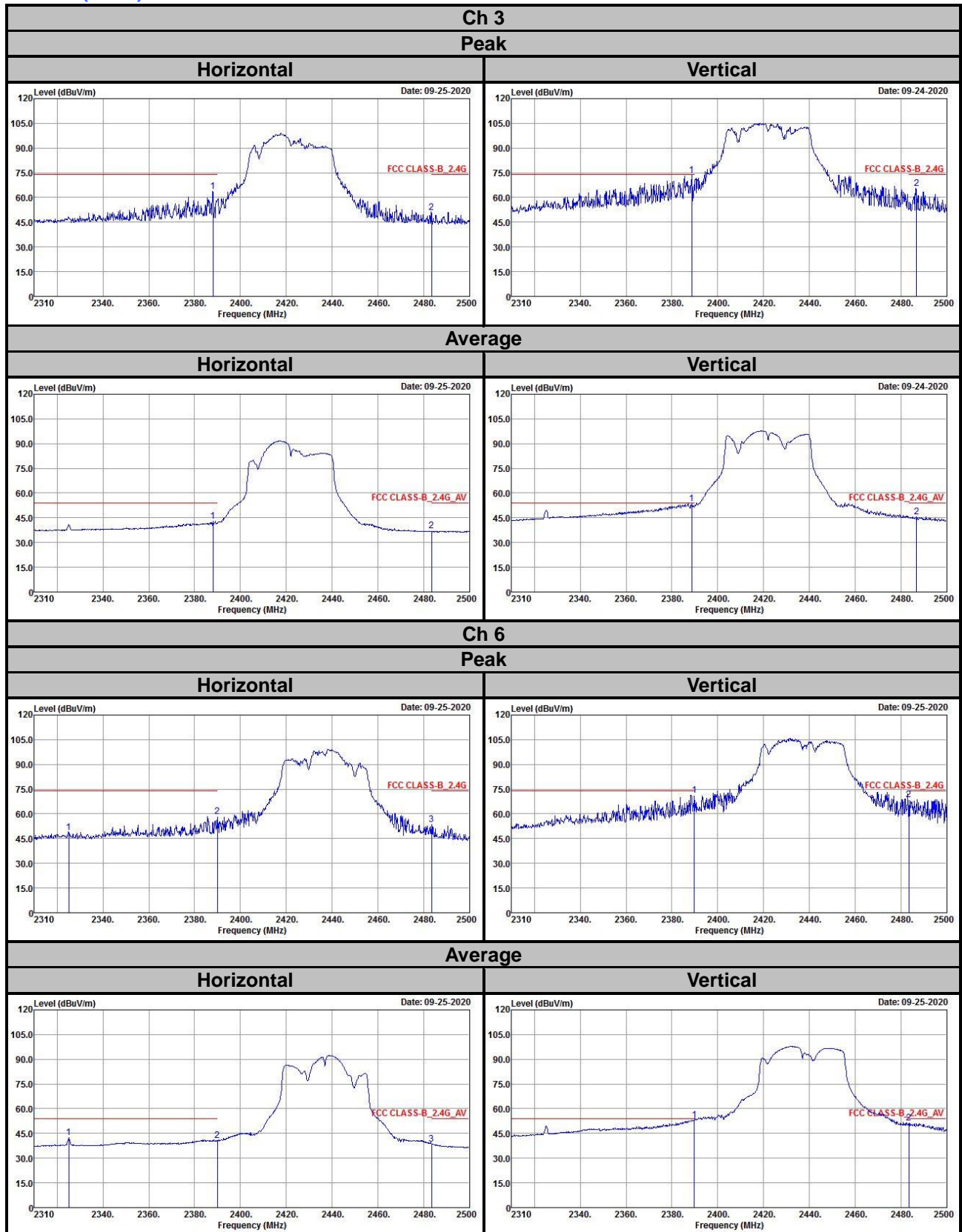

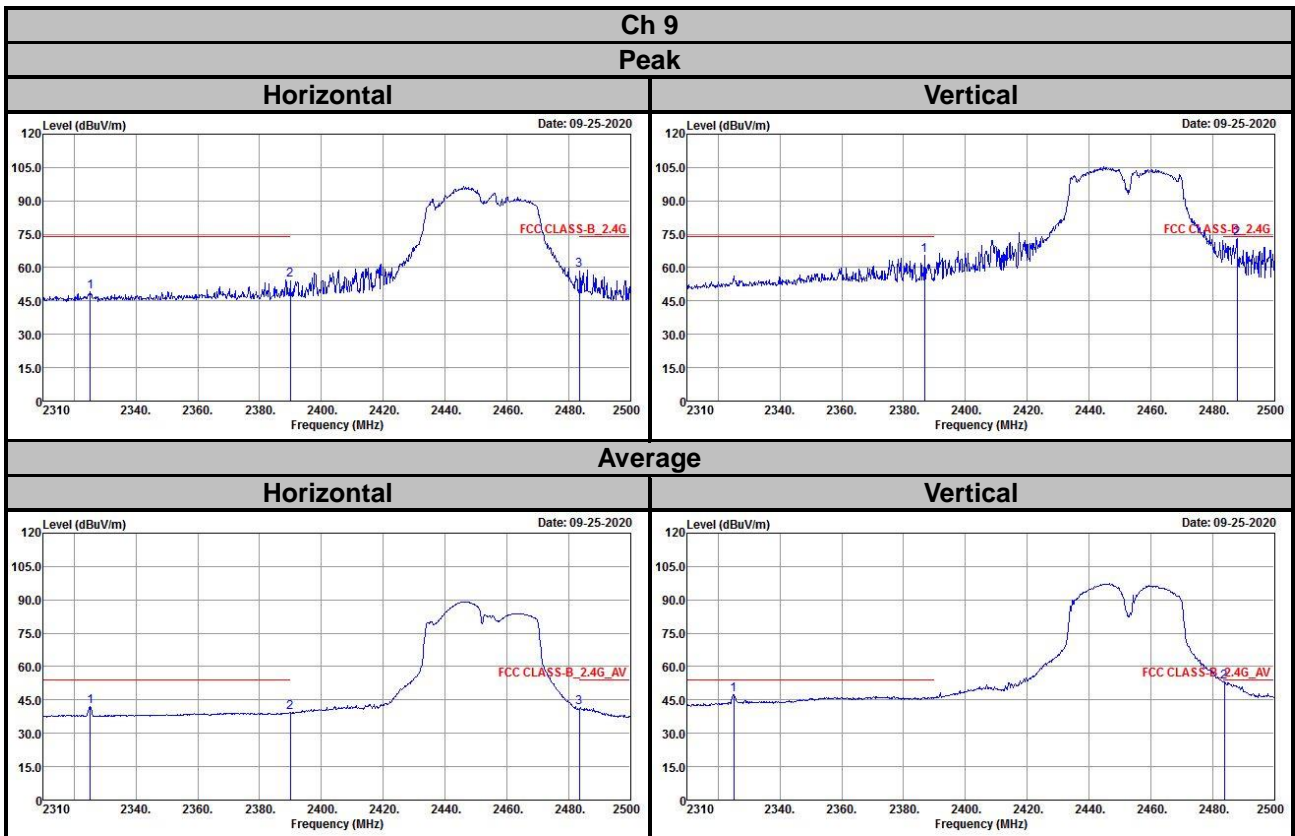

Appendix – Information of the Testing Laboratories

We, Bureau Veritas Consumer Products Services (H.K.) Ltd., Taoyuan Branch, were founded in 1988 to provide our best service in EMC, Radio, Telecom and Safety consultation. Our laboratories are FCC recognized accredited test firms and accredited according to ISO/IEC 17025.

If you have any comments, please feel free to contact us at the following:

Lin Kou EMC/RF Lab

Tel: 886-2-26052180

Fax: 886-2-26051924

Hsin Chu EMC/RF/Telecom Lab

Tel: 886-3-6668565

Fax: 886-3-6668323

Hwa Ya EMC/RF/Safety Lab

Tel: 886-3-3183232

Fax: 886-3-3270892

Email: service.adt@tw.bureauveritas.com

Web Site: www.bureauveritas-adt.com

The address and road map of all our labs can be found in our web site also.

--- END ---