



FCC TEST REPORT (15.407)

REPORT NO.: RF130207E02-1

MODEL NO.: DIR-850L

RF ID: KA2IR850LA1

RECEIVED: Feb. 07, 2013

TESTED: Feb. 08 to 19, 2013

ISSUED: Feb. 22, 2013

APPLICANT: D-Link Corporation

ADDRESS: No.289, Sinhu 3rd Rd., Neihu District, Taipei
City 114, Taiwan, R.O.C.

ISSUED BY: Bureau Veritas Consumer Products Services
(H.K.) Ltd., Taoyuan Branch Hsin Chu Laboratory

LAB ADDRESS : No. 81-1, Lu Liao Keng, 9th Ling, Wu Lung Tsuen,
Chiung Lin Hsiang, Hsin Chu Hsien 307, Taiwan,
R.O.C.

TEST LOCATION (1): No. 81-1, Lu Liao Keng, 9th Ling, Wu Lung Tsuen,
Chiung Lin Hsiang, Hsin Chu Hsien 307, Taiwan,
R.O.C.

TEST LOCATION (2): No. 49, Ln. 206, Wende Rd., Shangshan Tsuen,
Chiung Lin Hsiang, Hsin Chu Hsien 307, Taiwan,
R.O.C.

This report should not be used by the client to claim product certification, approval, or endorsement by TAF or any government agencies.



This report is for your exclusive use. Any copying or replication of this report to or for any other person or entity, or use of our name or trademark, is permitted only with our prior written permission. This report sets forth our findings solely with respect to the test samples identified herein. The results set forth in this report are not indicative or representative of the quality or characteristics of the lot from which a test sample was taken or any similar or identical product unless specifically and expressly noted. Our report includes all of the tests requested by you and the results thereof based upon the information that you provided to us. You have 60 days from date of issuance of this report to notify us of any material error or omission caused by our negligence, provided, however, that such notice shall be in writing and shall specifically address the issue you wish to raise. A failure to raise such issue within the prescribed time shall constitute your unqualified acceptance of the completeness of this report, the tests conducted and the correctness of the report contents. Unless specific mention, the uncertainty of measurement has been explicitly taken into account to declare the compliance or non-compliance to the specification



A D T

Table of Contents

| | |
|--|----|
| RELEASE CONTROL RECORD | 4 |
| 1. CERTIFICATION | 5 |
| 2. SUMMARY OF TEST RESULTS | 6 |
| 2.1 MEASUREMENT UNCERTAINTY | 7 |
| 3. GENERAL INFORMATION | 8 |
| 3.1 GENERAL DESCRIPTION OF EUT | 8 |
| 3.2 DESCRIPTION OF TEST MODES | 12 |
| 3.2.1 TEST MODE APPLICABILITY AND TESTED CHANNEL DETAIL | 13 |
| 3.3 GENERAL DESCRIPTION OF APPLIED STANDARDS | 15 |
| 3.4 DUTY CYCLE OF TEST SIGNAL | 16 |
| 3.5 DESCRIPTION OF SUPPORT UNITS..... | 17 |
| 3.6 CONFIGURATION OF SYSTEM UNDER TEST | 18 |
| 4. TEST TYPES AND RESULTS | 19 |
| 4.1 CONDUCTED EMISSION MEASUREMENT | 19 |
| 4.1.1 LIMITS OF CONDUCTED EMISSION MEASUREMENT | 19 |
| 4.1.2 TEST INSTRUMENTS..... | 19 |
| 4.1.3 TEST PROCEDURES | 20 |
| 4.1.4 DEVIATION FROM TEST STANDARD | 20 |
| 4.1.5 TEST SETUP | 20 |
| 4.1.6 EUT OPERATING CONDITIONS | 21 |
| 4.1.7 TEST RESULTS (MODE 1) | 22 |
| 4.1.8 TEST RESULTS (MODE 2) | 24 |
| 4.2 RADIATED EMISSION AND BANDEDGE MEASUREMENT | 26 |
| 4.2.1 LIMITS OF RADIATED EMISSION AND BANDEDGE MEASUREMENT..... | 26 |
| 4.2.2 LIMITS OF UNWANTED EMISSION OUT OF THE RESTRICTED BANDS..... | 26 |
| 4.2.3 TEST INSTRUMENTS..... | 27 |
| 4.2.4 TEST PROCEDURES | 28 |
| 4.2.5 DEVIATION FROM TEST STANDARD | 28 |
| 4.2.6 TEST SETUP | 29 |
| 4.2.7 EUT OPERATING CONDITION..... | 29 |
| 4.2.8 TEST RESULTS | 30 |
| 4.3 TRANSMIT POWER MEASUREMENT | 40 |
| 4.3.1 LIMITS OF TRANSMIT POWER MEASUREMENT | 40 |
| 4.3.2 TEST INSTRUMENTS..... | 40 |
| 4.3.3 TEST PROCEDURE..... | 41 |
| 4.3.4 DEVIATION FROM TEST STANDARD | 42 |
| 4.3.5 TEST SETUP | 42 |
| 4.3.6 EUT OPERATING CONDITIONS | 42 |



A D T

| | | |
|-------|---|----|
| 4.3.7 | TEST RESULTS | 43 |
| 4.4 | PEAK POWER SPECTRAL DENSITY MEASUREMENT | 45 |
| 4.4.1 | LIMITS OF PEAK POWER SPECTRAL DENSITY MEASUREMENT | 45 |
| 4.4.2 | TEST INSTRUMENTS..... | 45 |
| 4.4.3 | TEST PROCEDURES | 45 |
| 4.4.4 | DEVIATION FROM TEST STANDARD | 45 |
| 4.4.5 | TEST SETUP | 46 |
| 4.4.6 | EUT OPERATING CONDITIONS | 46 |
| 4.4.7 | TEST RESULTS | 47 |
| 4.5 | PEAK POWER EXCURSION MEASUREMENT | 49 |
| 4.5.1 | LIMITS OF PEAK POWER EXCURSION MEASUREMENT | 49 |
| 4.5.2 | TEST INSTRUMENTS..... | 49 |
| 4.5.3 | TEST PROCEDURE..... | 49 |
| 4.5.4 | DEVIATION FROM TEST STANDARD | 49 |
| 4.5.5 | TEST SETUP | 49 |
| 4.5.6 | EUT OPERATING CONDITIONS | 49 |
| 4.5.7 | TEST RESULTS | 50 |
| 4.6 | FREQUENCY STABILITY..... | 51 |
| 4.6.1 | LIMITS OF FREQUENCY STABILITY MEASUREMENT | 51 |
| 4.6.2 | TEST INSTRUMENTS..... | 51 |
| 4.6.3 | TEST PROCEDURE..... | 51 |
| 4.6.4 | DEVIATION FROM TEST STANDARD | 52 |
| 4.6.5 | TEST SETUP | 52 |
| 4.6.6 | EUT OPERATING CONDITION..... | 52 |
| 4.6.7 | TEST RESULTS | 53 |
| 5. | PHOTOGRAPHS OF THE TEST CONFIGURATION..... | 54 |
| 6. | INFORMATION ON THE TESTING LABORATORIES | 55 |
| 7. | APPENDIX A - MODIFICATIONS RECORDERS FOR ENGINEERING CHANGES TO THE EUT BY THE LAB..... | 56 |



A D T

RELEASE CONTROL RECORD

| ISSUE NO. | REASON FOR CHANGE | DATE ISSUED |
|---------------|-------------------|---------------|
| RF130207E02-1 | Original release | Feb. 22, 2013 |



A D T

1. CERTIFICATION

PRODUCT: Wireless AC1200 Dual Band Gigabit Cloud Router
BRAND NAME: D-Link
MODEL NO.: DIR-850L
TEST SAMPLE: R&D SAMPLE
APPLICANT: D-Link Corporation
TESTED: Feb. 08 to 19, 2013
STANDARDS: FCC Part 15, Subpart E (Section 15.407)
ANSI C63.10-2009

The above equipment (Model: DIR-850L) has been tested by **Bureau Veritas Consumer Products Services (H.K.) Ltd., Taoyuan Branch**, and found compliance with the requirement of the above standards. The test record, data evaluation & Equipment Under Test (EUT) configurations represented herein are true and accurate accounts of the measurements of the sample's EMC characteristics under the conditions specified in this report.

PREPARED BY : Phoenix Huang , **DATE:** Feb. 22, 2013
(Phoenix Huang, Specialist)

APPROVED BY : May Chen , **DATE:** Feb. 22, 2013
(May Chen, Deputy Manager)



A D T

2. SUMMARY OF TEST RESULTS

The EUT has been tested according to the following specifications:

For 5GHz, 5150~5250MHz

| APPLIED STANDARD: FCC PART 15, SUBPART E (SECTION 15.407) | | | |
|---|-----------------------------|--------|---|
| STANDARD SECTION | TEST TYPE | RESULT | REMARK |
| 15.407(b)(6) | AC Power Conducted Emission | PASS | Meet the requirement of limit. Minimum passing margin is -13.97dB at 0.16172MHz |
| 15.407(b/1/2/3) (b)(5) | Spurious Emissions | PASS | Meet the requirement of limit. Minimum passing margin is -0.5dB at 5150.00MHz |
| 15.407(a/1/2/3) | Transmit Power | PASS | Meet the requirement of limit. |
| 15.407(a)(6) | Peak Power Excursion | PASS | Meet the requirement of limit. |
| 15.407(a/1/2/3) | Peak Power Spectral Density | PASS | Meet the requirement of limit. |
| 15.407(g) | Frequency Stability | PASS | Meet the requirement of limit. |
| 15.203 | Antenna Requirement | PASS | Antenna connector is IPEX not a standard connector. |

NOTE: The EUT was operating in 2.400 ~ 2.4835GHz, 5.15~5.25GHz and 5.725~5.850GHz frequencies band. This report was recorded the RF parameters including 5.15~5.25GHz. For the 2.400 ~ 2.4835GHz and 5.725~5.850GHz RF parameters was recorded in another test report.



A D T

2.1 MEASUREMENT UNCERTAINTY

Where relevant, the following measurement uncertainty levels have been estimated for tests performed on the EUT as specified in CISPR 16-4-2:

This uncertainty represents an expanded uncertainty expressed at approximately the 95% confidence level using a coverage factor of $k=2$.

| Measurement | Value |
|-----------------------------------|---------|
| Conducted emissions | 2.98 dB |
| Radiated emissions (30MHz-1GHz) | 5.63 dB |
| Radiated emissions (1GHz -6GHz) | 3.73 dB |
| Radiated emissions (6GHz -18GHz) | 3.90 dB |
| Radiated emissions (18GHz -40GHz) | 4.11 dB |



A D T

3. GENERAL INFORMATION

3.1 GENERAL DESCRIPTION OF EUT

| | |
|------------------------------|--|
| PRODUCT | Wireless AC1200 Dual Band Gigabit Cloud Router |
| MODEL NO. | DIR-850L |
| POWER SUPPLY | DC 12V from power adapter |
| MODULATION TYPE | CCK, DQPSK, DBPSK for DSSS 64QAM, 16QAM, QPSK, BPSK for OFDM 256QAM for OFDM in 11ac mode only. |
| MODULATION TECHNOLOGY | DSSS,OFDM |
| TRANSFER RATE | 802.11b: up to 11Mbps 802.11a / g: up to 54Mbps 802.11n: up to 450Mbps 802.11ac: up to 866.7Mbps |
| OPERATING FREQUENCY | For 15.407 802.11a/n/ac: 5.18 ~ 5.24GHz |
| | For 15.247 802.11b/g/n: 2.412 ~ 2.462GHz 802.11a/n/ac: 5.745 ~ 5.825GHz |
| NUMBER OF CHANNEL | For 15.407 4 for 802.11a, 802.11n (HT20), 802.11ac (VHT20) 2 for 802.11n (HT40), 802.11ac (VHT40) 1 for 802.11ac (VHT80) |
| | For 15.247 (2.4GHz) 11 for 802.11b, 802.11g, 802.11n (HT20) 7 for 802.11n (HT40) For 15.247 (5GHz) 5 for 802.11a, 802.11n (HT20), 802.11ac (VHT20) 2 for 802.11n (HT40), 802.11ac (VHT40) 1 for 802.11ac (VHT80) |

| | |
|-----------------------------|--|
| MAXIMUM OUTPUT POWER | For 15.407 802.11a: 46.351mW 802.11n (HT20): 45.296mW 802.11n (HT40): 43.767mW 802.11ac (VHT80): 28.749mW For 15.247 (2.4GHz) 802.11b: 372.812mW 802.11g: 178.250mW 802.11n (HT20): 174.239mW 802.11n (HT40): 70.155mW For 15.247 (5GHz) 802.11a: 146.575mW 802.11n (HT20): 144.926mW 802.11n (HT40): 113.778mW 802.11ac (VHT80): 193.951mW |
| ANTENNA TYPE | Please see NOTE |
| DATA CABLE | NA |
| I/O PORTS | Refer to user's manual |
| ASSOCIATED DEVICES | Adapter x1 |

NOTE:

1. The EUT is a 2.4GHz & 5GHz WLAN device.
2. The EUT must be supplied with a power adapter and following two different models could be chosen as following table:

| No | Brand | Model No. | Spec. | Plug |
|----|--------|----------------|---|------|
| 1 | D-Link | SAG024F 4 US | Input: 100-240V, 0.8A, 47-63Hz Output: 12V, 2A DC output cable (Unshielded, 1.5m) | US |
| 2 | D-Link | AMS4-1202000FU | Input: 100-240V, 0.8A, 50-60Hz Output: 12V, 2A DC output cable (Unshielded, 1.5m) | US |

Note: 1. For radiated emissions test, the EUT was pre-tested with above adapters 1 & 2, the worst case was found in adapter 1. Therefore only the test data of the adapter 1 was recorded in this report.

3. The antenna provided to the EUT, please refer to the following table:

| For 2.4GHz | | | | | | | | |
|---------------------|------------|-------------------|--------------|--------------------------------------|------------------------------|----------------|-----------------|-------------------|
| Transmitter Circuit | Brand | Model | Antenna Type | Peak Gain (dBi) (Include cable loss) | Frequency range (MHz to MHz) | Connector Type | Cable Loss (dB) | Cable Length (cm) |
| Chain (1) | MAG.LAYERS | PCA-5010-2G4C1-A1 | PCB Dipole | 2.67 | 2400~2500 | NA | NA | 6.5 |
| Chain (0) | Alpha | NA | Printed | 2.94 | 2400~2500 | NA | NA | 5 |
| For 5GHz | | | | | | | | |
| Transmitter Circuit | Brand | Model | Antenna Type | Peak Gain (dBi) (Include cable loss) | Frequency range (MHz to MHz) | Connector Type | Cable Loss (dB) | Cable Length (cm) |
| Chain (1) | MAG.LAYERS | PCA-2010-5G0C1-A4 | PCB Dipole | 2.25 | 4900~5825 | IPEX | NA | 11 |
| Chain (0) | MAG.LAYERS | PCA-2010-5G0C1-A4 | PCB Dipole | 2.25 | 4900~5825 | IPEX | NA | 11 |

4. The EUT incorporates a MIMO function without beam forming.

| MODULATION MODE | TX/RX FUNCTION |
|--------------------------------------|-----------------------|
| 802.11b | 2Tx/2Rx |
| 802.11g | 2Tx/2Rx |
| 802.11n (HT20) <2.4GHz> | 2Tx/2Rx |
| 802.11n (HT40) <2.4GHz> | 2Tx/2Rx |
| 802.11a | 2Tx/2Rx |
| 802.11n (HT20) <5GHz> | 2Tx/2Rx |
| 802.11n (HT40) <5GHz> | 2Tx/2Rx |
| 802.11ac (VHT20) | 2Tx/2Rx |
| 802.11ac (VHT40) | 2Tx/2Rx |
| 802.11ac (VHT80) | 2Tx/2Rx |

Note: The modulation and bandwidth are similar for 802.11n mode for 20MHz (40MHz) and 802.11ac mode for 20MHz (40MHz), therefore investigated worst case to representative mode in test report. (Final test mode refer section 3.2.1)

5. Conducted emission and radiated emission of the simultaneous operation (2.4GHz & 5GHz) has been evaluated and no non-compliance was found.

6. When the EUT operating in 802.11n, the software operation, which is defined by manufacturer, MCS (Modulation and Coding Schemes) from 0 to 15.



A D T

7. When the EUT operating in 802.11ac, the software operation, which is defined by manufacturer, MCS (Modulation and Coding Schemes) from 0 to 9.
8. The above EUT information was declared by the manufacturer and for more detailed features description, please refer to the manufacturer's specifications or User's Manual.



A D T

3.2 DESCRIPTION OF TEST MODES

Operated in 5150 ~ 5250MHz band:

4 channels are provided for 802.11a, 802.11n (HT20), 802.11ac (VHT20):

| CHANNEL | FREQUENCY |
|---------|-----------|
| 36 | 5180 MHz |
| 40 | 5200 MHz |
| 44 | 5220 MHz |
| 48 | 5240 MHz |

2 channels are provided for 802.11n (HT40), 802.11ac (VHT40):

| CHANNEL | FREQUENCY |
|---------|-----------|
| 38 | 5190 MHz |
| 46 | 5230 MHz |

1 channels are provided for 802.11ac (VHT80):

| CHANNEL | FREQUENCY |
|---------|-----------|
| 42 | 5210 MHz |



A D T

3.2.1 TEST MODE APPLICABILITY AND TESTED CHANNEL DETAIL

| EUT CONFIGURE MODE | APPLICABLE TO | | | | DESCRIPTION |
|--------------------|---------------|---------|---------|------|-------------|
| | PLC | RE < 1G | RE ≥ 1G | APCM | |
| 1 | √ | √ | √ | √ | Adapter 1 |
| 2 | √ | - | - | - | Adapter 2 |

Where **PLC**: Power Line Conducted Emission **RE < 1G**: Radiated Emission below 1GHz
RE ≥ 1G: Radiated Emission above 1GHz **APCM**: Antenna Port Conducted Measurement

POWER LINE CONDUCTED EMISSION TEST:

- Pre-Scan has been conducted to determine the worst-case mode from all possible combinations between available modulations, data rates and antenna ports (if EUT with antenna diversity architecture).
- Following channel(s) was (were) selected for the final test as listed below.

| MODE | AVAILABLE CHANNEL | TESTED CHANNEL | MODULATION TECHNOLOGY | MODULATION TYPE | DATA RATE (MBPS) |
|---------|-------------------|----------------|-----------------------|-----------------|------------------|
| 802.11a | 36 to 48 | 36 | OFDM | BPSK | 6 |

RADIATED EMISSION TEST (BELOW 1 GHz):

- Pre-Scan has been conducted to determine the worst-case mode from all possible combinations between available modulations, data rates and antenna ports (if EUT with antenna diversity architecture).
- Following channel(s) was (were) selected for the final test as listed below.

| MODE | AVAILABLE CHANNEL | TESTED CHANNEL | MODULATION TECHNOLOGY | MODULATION TYPE | DATA RATE (Mbps) |
|---------|-------------------|----------------|-----------------------|-----------------|------------------|
| 802.11a | 36 to 48 | 36 | OFDM | BPSK | 6 |



A D T

RADIATED EMISSION TEST (ABOVE 1 GHz):

- Pre-Scan has been conducted to determine the worst-case mode from all possible combinations between available modulations, data rates and antenna ports (if EUT with antenna diversity architecture).
- Following channel(s) was (were) selected for the final test as listed below.

| MODE | AVAILABLE CHANNEL | TESTED CHANNEL | MODULATION TECHNOLOGY | MODULATION TYPE | DATA RATE (Mbps) |
|------------------|-------------------|----------------|-----------------------|-----------------|------------------|
| 802.11a | 36 to 48 | 36, 40, 48 | OFDM | BPSK | 6 |
| 802.11n (HT20) | 36 to 48 | 36, 40, 48 | OFDM | BPSK | 6.5 |
| 802.11n (HT40) | 38 to 46 | 38, 46 | OFDM | BPSK | 13.5 |
| 802.11ac (VHT80) | 42 | 42 | OFDM | BPSK | 58.5 |

ANTENNA PORT CONDUCTED MEASUREMENT:

- Pre-Scan has been conducted to determine the worst-case mode from all possible combinations between available modulations, data rates and antenna ports (if EUT with antenna diversity architecture).
- Following channel(s) was (were) selected for the final test as listed below.

| MODE | AVAILABLE CHANNEL | TESTED CHANNEL | MODULATION TECHNOLOGY | MODULATION TYPE | DATA RATE (Mbps) |
|------------------|-------------------|----------------|-----------------------|-----------------|------------------|
| 802.11a | 36 to 48 | 36, 40, 48 | OFDM | BPSK | 6 |
| 802.11n (HT20) | 36 to 48 | 36, 40, 48 | OFDM | BPSK | 6.5 |
| 802.11n (HT40) | 38 to 46 | 38, 46 | OFDM | BPSK | 13.5 |
| 802.11ac (VHT80) | 42 | 42 | OFDM | BPSK | 58.5 |

TEST CONDITION:

| APPLICABLE TO | ENVIRONMENTAL CONDITIONS | INPUT POWER | TESTED BY |
|--------------------|--------------------------|--------------|--------------|
| PLC | 21deg. C, 60%RH | 120Vac, 60Hz | Scott Chen |
| RE<1G | 23deg. C, 66%RH | 120Vac, 60Hz | Robert Cheng |
| RE ³ 1G | 23deg. C, 69%RH | 120Vac, 60Hz | Amos Chuang |
| APCM | 25deg. C, 60%RH | 120Vac, 60Hz | Amos Chuang |

3.3 GENERAL DESCRIPTION OF APPLIED STANDARDS

The EUT is a RF product. According to the specifications of the manufacturer, it must comply with the requirements of the following standards:

FCC Part 15, Subpart E (15.407)

789033 D01 General UNII Test Procedures v01 r02

662911 D01 Multiple Transmitter Output v01 r02

ANSI C63.10-2009

All test items have been performed and recorded as per the above standards.

Note: The EUT has been verified to comply with the requirements of FCC Part 15, Subpart B, Class B (DoC). The test report has been issued separately.



A D T

3.4 DUTY CYCLE OF TEST SIGNAL

Duty cycle of test signal is 100 %, duty factor is not required.

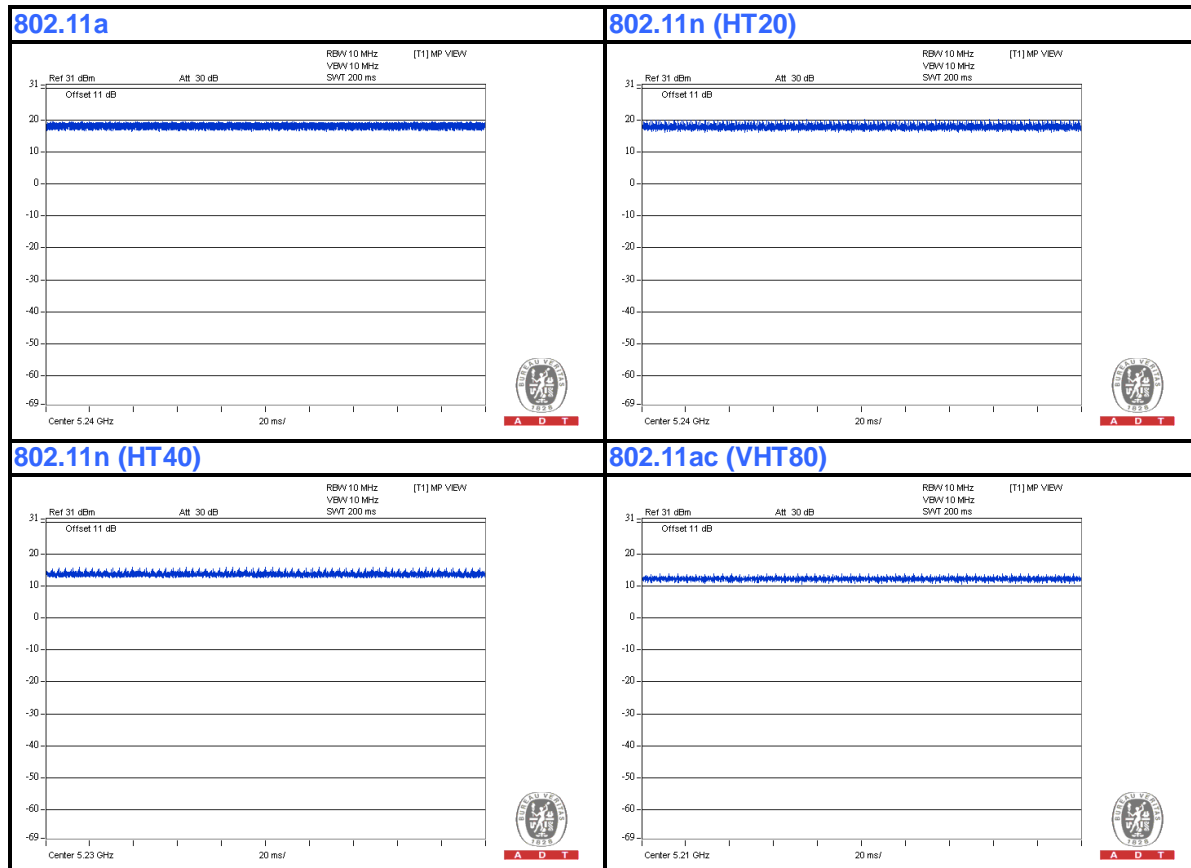



A D T

3.5 DESCRIPTION OF SUPPORT UNITS

The EUT has been tested as an independent unit together with other necessary accessories or support units. The following support units or accessories were used to form a representative test configuration during the tests.

| NO. | PRODUCT | BRAND | MODEL NO. | SERIAL NO. | FCC ID |
|-----|-------------------|-------|-----------|-------------------|---------|
| 1 | NOTEBOOK COMPUTER | DELL | PP32LA | FSLB32S | FCC DoC |
| 2 | NOTEBOOK COMPUTER | DELL | PP32LA | GSLB32S | FCC DoC |
| 3 | HUB | ZyXEL | ES-116P | S060H0200021 5 | FCC DoC |
| 4 | iPod shuffle | Apple | MC749TA/A | CC4DMFJUDFD M | NA |

| NO. | SIGNAL CABLE DESCRIPTION OF THE ABOVE SUPPORT UNITS |
|-----|---|
| 1 | UTP cable, 10m |
| 2 | UTP cable, 10m |
| 3 | UTP cable, 10m |
| 4 | USB cable, 0.1m |

NOTE: All power cords of the above support units are non shielded (1.8m).

3.6 CONFIGURATION OF SYSTEM UNDER TEST

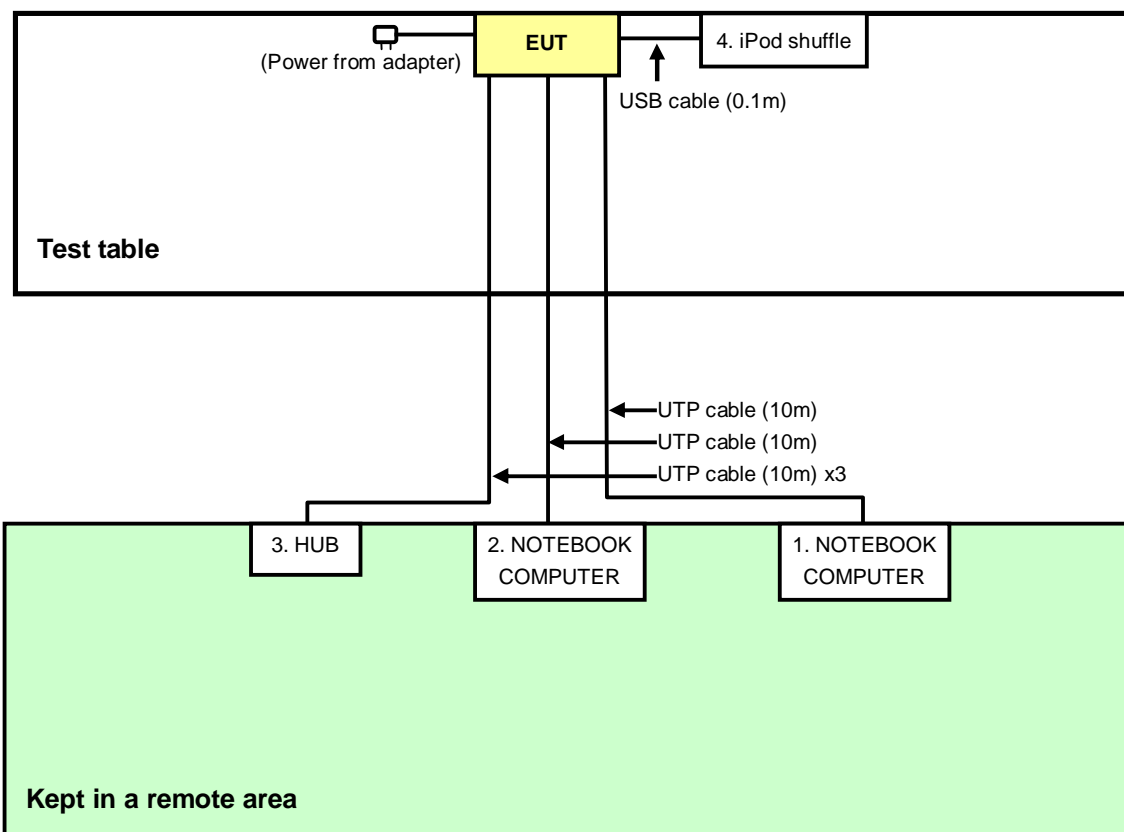

4. TEST TYPES AND RESULTS

4.1 CONDUCTED EMISSION MEASUREMENT

4.1.1 LIMITS OF CONDUCTED EMISSION MEASUREMENT

| FREQUENCY OF EMISSION (MHz) | CONDUCTED LIMIT (dB μ V) | |
|-----------------------------|------------------------------|----------|
| | Quasi-peak | Average |
| 0.15-0.5 | 66 to 56 | 56 to 46 |
| 0.5-5 | 56 | 46 |
| 5-30 | 60 | 50 |

- NOTE:**
1. The lower limit shall apply at the transition frequencies.
 2. The limit decreases in line with the logarithm of the frequency in the range of 0.15 to 0.50 MHz.

4.1.2 TEST INSTRUMENTS

| DESCRIPTION & MANUFACTURER | MODEL NO. | SERIAL NO. | CALIBRATED DATE | CALIBRATED UNTIL |
|---|-------------------------|------------|-----------------|------------------|
| Test Receiver | ESCS 30 | 100375 | Mar. 12, 2012 | Mar.11, 2013 |
| Line-Impedance Stabilization Network (for EUT) SCHWARZBECK | NSLK8127 | 8127-522 | Sep. 06, 2012 | Sep. 05, 2013 |
| Line-Impedance Stabilization Network (for Peripheral) | ENV216 | 100072 | June 08,2012 | June 07,2013 |
| RF Cable (JYEBAO) | 5DFB | COCCAB-001 | Aug. 28, 2012 | Aug. 27, 2013 |
| 50 ohms Terminator | 50 | EMC-3 | Sep. 25, 2012 | Sep. 24, 2013 |
| Software ADT | BV ADT_Cond_V7.3.7.3 | NA | NA | NA |

Note:

1. The calibration interval of the above test instruments is 12 months and the calibrations are traceable to NML/ROC and NIST/USA.
2. The test was performed in Shielded Room No. C.
- 3 The VCCI Con C Registration No. is C-3611.
- 4 Tested Date: Feb. 08, 2013

4.1.3 TEST PROCEDURES

- a. The EUT was placed 0.4 meters from the conducting wall of the shielded room with EUT being connected to the power mains through a line impedance stabilization network (LISN). Other support units were connected to the power mains through another LISN.
- b. The two LISNs provide 50 ohm/ 50uH of coupling impedance for the measuring instrument.
- c. Both lines of the power mains connected to the EUT were checked for maximum conducted interference.
- d. The frequency range from 150kHz to 30MHz was searched. Emission level under (Limit – 20dB) was not recorded.

NOTE:

1. The resolution bandwidth of test receiver is 9kHz for Quasi-peak detection (QP) & Average detection (AV).

4.1.4 DEVIATION FROM TEST STANDARD

No deviation

4.1.5 TEST SETUP

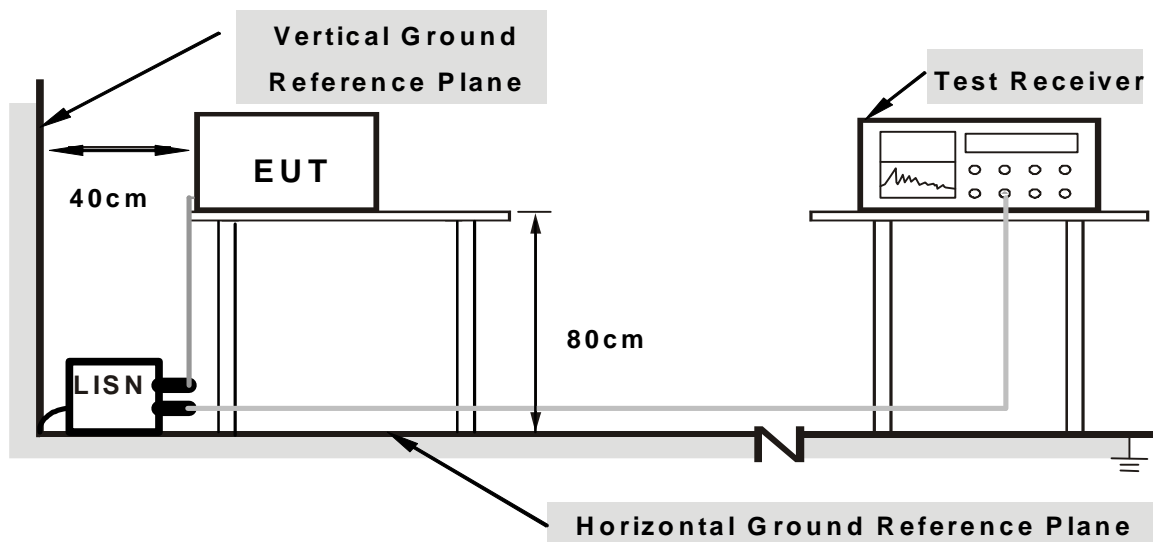

Note: 1.Support units were connected to second LISN.

For the actual test configuration, please refer to the related item – Photographs of the Test Configuration.

4.1.6 EUT OPERATING CONDITIONS

1. Connect the EUT with the support unit 1 (Notebook Computer) which is placed on a table in control room.
2. The communication partner run test program “MP TEST.exe (RTL819x 2.2.5)” to enable EUT under transmission/receiving condition continuously at specific channel frequency.

4.1.7 TEST RESULTS (MODE 1)

| | | | |
|-------|----------|-------------------|--------------------------------|
| PHASE | Line (L) | DETECTOR FUNCTION | Quasi-Peak (QP) / Average (AV) |
|-------|----------|-------------------|--------------------------------|

| No | Freq. [MHz] | Corr. Factor [dB] | Reading Value [dB (uV)] | | Emission Level [dB (uV)] | | Limit [dB (uV)] | | Margin (dB) | |
|----|-------------|-------------------|-------------------------|-------|--------------------------|-------|-----------------|-------|-------------|--------|
| | | | Q.P. | AV. | Q.P. | AV. | Q.P. | AV. | Q.P. | AV. |
| | 1 | 0.15781 | 0.11 | 51.32 | 39.72 | 51.43 | 39.83 | 65.58 | 55.58 | -14.15 |
| 2 | 0.24375 | 0.13 | 39.02 | 30.22 | 39.15 | 30.35 | 61.97 | 51.97 | -22.82 | -21.62 |
| 3 | 0.40391 | 0.16 | 34.97 | 31.28 | 35.13 | 31.44 | 57.77 | 47.77 | -22.64 | -16.33 |
| 4 | 0.61875 | 0.17 | 26.71 | 15.03 | 26.88 | 15.20 | 56.00 | 46.00 | -29.12 | -30.80 |
| 5 | 1.08984 | 0.19 | 23.08 | 17.63 | 23.27 | 17.82 | 56.00 | 46.00 | -32.73 | -28.18 |
| 6 | 10.56641 | 0.58 | 25.53 | 20.71 | 26.11 | 21.29 | 60.00 | 50.00 | -33.89 | -28.71 |

REMARKS:

1. Q.P. and AV. are abbreviations of quasi-peak and average individually.
2. The emission levels of other frequencies were very low against the limit.
3. Margin value = Emission level - Limit value
4. Correction factor = Insertion loss + Cable loss
5. Emission Level = Correction Factor + Reading Value.

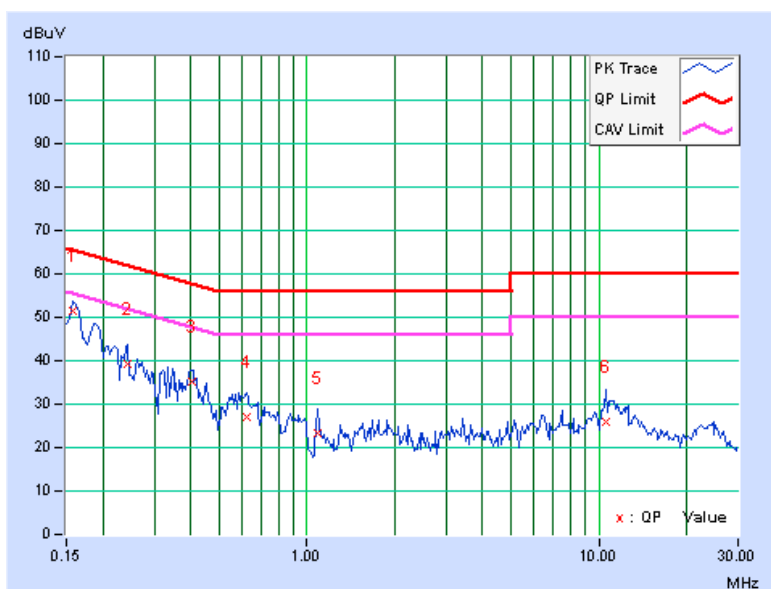



A D T

| | | | |
|--------------|-------------|--------------------------|--------------------------------|
| PHASE | Neutral (N) | DETECTOR FUNCTION | Quasi-Peak (QP) / Average (AV) |
|--------------|-------------|--------------------------|--------------------------------|

| No | Freq. [MHz] | Corr. Factor (dB) | Reading Value [dB (uV)] | | Emission Level [dB (uV)] | | Limit [dB (uV)] | | Margin (dB) | |
|----|----------------|-------------------------|----------------------------|-------|-----------------------------|-------|--------------------|-------|----------------|--------|
| | | | Q.P. | AV. | Q.P. | AV. | Q.P. | AV. | Q.P. | AV. |
| | 1 | 0.16172 | 0.09 | 51.32 | 41.23 | 51.41 | 41.32 | 65.38 | 55.38 | -13.97 |
| 2 | 0.24375 | 0.11 | 39.76 | 31.58 | 39.87 | 31.69 | 61.97 | 51.97 | -22.10 | -20.28 |
| 3 | 0.39219 | 0.15 | 33.17 | 27.10 | 33.32 | 27.25 | 58.02 | 48.02 | -24.70 | -20.77 |
| 4 | 0.65391 | 0.16 | 26.43 | 20.99 | 26.59 | 21.15 | 56.00 | 46.00 | -29.41 | -24.85 |
| 5 | 2.85156 | 0.22 | 23.00 | 18.37 | 23.22 | 18.59 | 56.00 | 46.00 | -32.78 | -27.41 |
| 6 | 10.75391 | 0.44 | 23.89 | 19.12 | 24.33 | 19.56 | 60.00 | 50.00 | -35.67 | -30.44 |

REMARKS:

1. Q.P. and AV. are abbreviations of quasi-peak and average individually.
2. The emission levels of other frequencies were very low against the limit.
3. Margin value = Emission level - Limit value
4. Correction factor = Insertion loss + Cable loss
5. Emission Level = Correction Factor + Reading Value.

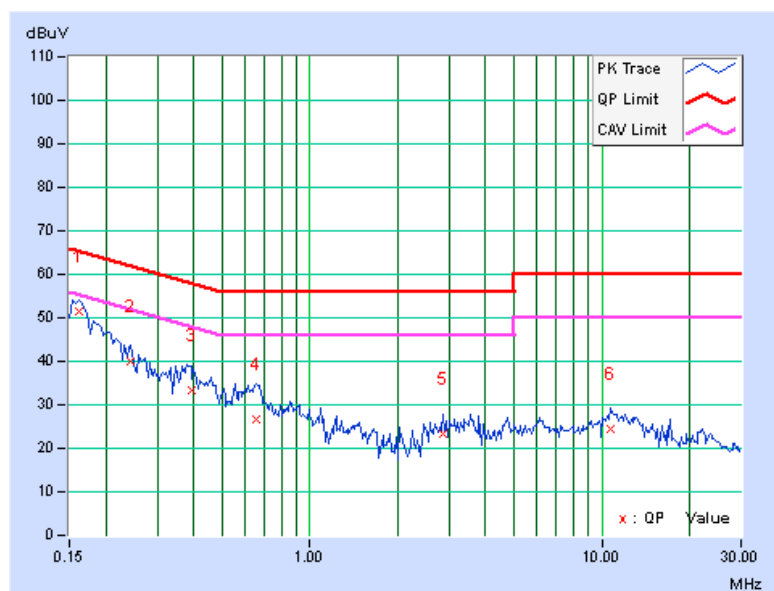

4.1.8 TEST RESULTS (MODE 2)

| | | | |
|--------------|----------|--------------------------|--------------------------------|
| PHASE | Line (L) | DETECTOR FUNCTION | Quasi-Peak (QP) / Average (AV) |
|--------------|----------|--------------------------|--------------------------------|

| No | Freq. [MHz] | Corr. Factor (dB) | Reading Value [dB (uV)] | | Emission Level [dB (uV)] | | Limit [dB (uV)] | | Margin (dB) | |
|----|----------------|-------------------------|----------------------------|-------|-----------------------------|-------|--------------------|-------|----------------|--------|
| | | | Q.P. | AV. | Q.P. | AV. | Q.P. | AV. | Q.P. | AV. |
| | 1 | 0.15000 | 0.11 | 45.62 | 23.39 | 45.73 | 23.50 | 66.00 | 56.00 | -20.27 |
| 2 | 0.16562 | 0.11 | 44.31 | 32.56 | 44.42 | 32.67 | 65.18 | 55.18 | -20.76 | -22.51 |
| 3 | 0.19687 | 0.12 | 44.73 | 24.75 | 44.85 | 24.87 | 63.74 | 53.74 | -18.89 | -28.87 |
| 4 | 0.34141 | 0.15 | 39.61 | 28.08 | 39.76 | 28.23 | 59.17 | 49.17 | -19.41 | -20.94 |
| 5 | 1.08984 | 0.19 | 29.00 | 22.58 | 29.19 | 22.77 | 56.00 | 46.00 | -26.81 | -23.23 |
| 6 | 8.80469 | 0.50 | 32.33 | 26.80 | 32.83 | 27.30 | 60.00 | 50.00 | -27.17 | -22.70 |

REMARKS:

1. Q.P. and AV. are abbreviations of quasi-peak and average individually.
2. The emission levels of other frequencies were very low against the limit.
3. Margin value = Emission level - Limit value
4. Correction factor = Insertion loss + Cable loss
5. Emission Level = Correction Factor + Reading Value.

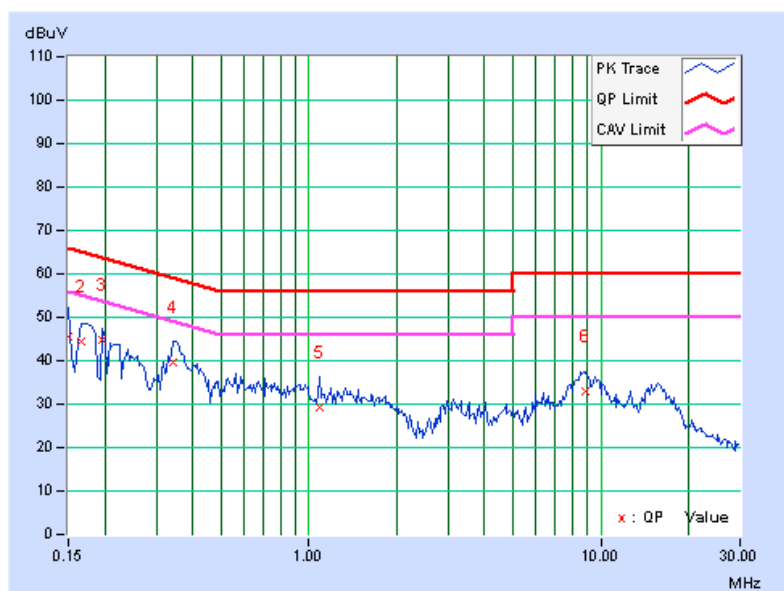

| | | | |
|--------------|-------------|--------------------------|--------------------------------|
| PHASE | Neutral (N) | DETECTOR FUNCTION | Quasi-Peak (QP) / Average (AV) |
|--------------|-------------|--------------------------|--------------------------------|

| No | Freq. [MHz] | Corr. Factor (dB) | Reading Value [dB (uV)] | | Emission Level [dB (uV)] | | Limit [dB (uV)] | | Margin (dB) | |
|----|----------------|-------------------------|----------------------------|-------|-----------------------------|-------|--------------------|-------|----------------|--------|
| | | | Q.P. | AV. | Q.P. | AV. | Q.P. | AV. | Q.P. | AV. |
| | 1 | 0.16953 | 0.09 | 45.08 | 34.44 | 45.17 | 34.53 | 64.98 | 54.98 | -19.81 |
| 2 | 0.20078 | 0.10 | 42.62 | 25.45 | 42.72 | 25.55 | 63.58 | 53.58 | -20.86 | -28.03 |
| 3 | 0.34531 | 0.14 | 37.07 | 25.82 | 37.21 | 25.96 | 59.07 | 49.07 | -21.87 | -23.12 |
| 4 | 0.65000 | 0.16 | 28.05 | 18.54 | 28.21 | 18.70 | 56.00 | 46.00 | -27.79 | -27.30 |
| 5 | 1.42578 | 0.19 | 29.56 | 23.43 | 29.75 | 23.62 | 56.00 | 46.00 | -26.25 | -22.38 |
| 6 | 9.46484 | 0.40 | 34.93 | 30.15 | 35.33 | 30.55 | 60.00 | 50.00 | -24.67 | -19.45 |

REMARKS:

1. Q.P. and AV. are abbreviations of quasi-peak and average individually.
2. The emission levels of other frequencies were very low against the limit.
3. Margin value = Emission level - Limit value
4. Correction factor = Insertion loss + Cable loss
5. Emission Level = Correction Factor + Reading Value.

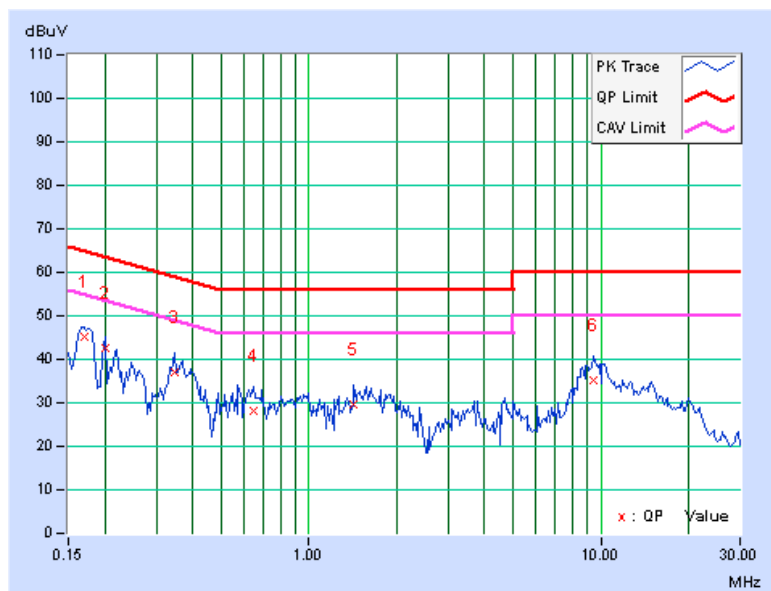



4.2 RADIATED EMISSION AND BANDEGE MEASUREMENT

4.2.1 LIMITS OF RADIATED EMISSION AND BANDEGE MEASUREMENT

Radiated emissions which fall in the restricted bands must comply with the radiated emission limits specified as below table:

| Frequencies (MHz) | Field strength (microvolts/meter) | Measurement distance (meters) |
|-------------------|-----------------------------------|-------------------------------|
| 0.009-0.490 | 2400/F(kHz) | 300 |
| 0.490-1.705 | 24000/F(kHz) | 30 |
| 1.705-30.0 | 30 | 30 |
| 30-88 | 100 | 3 |
| 88-216 | 150 | 3 |
| 216-960 | 200 | 3 |
| Above 960 | 500 | 3 |

NOTE:

1. The lower limit shall apply at the transition frequencies.
2. Emission level (dBuV/m) = 20 log Emission level (uV/m).
3. For frequencies above 1000MHz, the field strength limits are based on average detector, however, the peak field strength of any emission shall not exceed the maximum permitted average limits, specified above by more than 20dB under any condition of modulation.

4.2.2 LIMITS OF UNWANTED EMISSION OUT OF THE RESTRICTED BANDS

| APPLICABLE TO | LIMIT | |
|---------------|-------------------------------|--|
| - | FIELD STRENGTH AT 3m (dBµV/m) | |
| | PK | AV |
| | 74 | 54 |
| √ | EIRP LIMIT (dBm) | EQUIVALENT FIELD STRENGTH AT 3m (dBµV/m) |
| | PK | PK |
| | -27 | 68.3 |

NOTE:

1. The following formula is used to convert the equipment isotropic radiated power (eirp) to field strength:

$$E = \frac{1000000\sqrt{30P}}{3} \mu\text{V/m, where P is the eirp (Watts).$$



A D T

4.2.3 TEST INSTRUMENTS

| DESCRIPTION & MANUFACTURER | MODEL NO. | SERIAL NO. | CALIBRATED DATE | CALIBRATED UNTIL |
|---|--------------------------|-------------------------------------|-----------------|------------------|
| Spectrum Analyzer Agilent | E4446A | MY48250254 | July 09, 2012 | July 08, 2013 |
| Pre-Selector Agilent | N9039A | MY46520311 | July 09, 2012 | July 08, 2013 |
| Signal Generator Agilent | N5181A | MY49060517 | July 09, 2012 | July 08, 2013 |
| Pre-Amplifier Mini-Circuits | ZFL-1000VH2 B | AMP-ZFL-03 | Nov. 14, 2012 | Nov. 13, 2013 |
| Pre-Amplifier Agilent | 8449B | 3008A02578 | June 26, 2012 | June 25, 2013 |
| Pre-Amplifier SPACEK LABS | SLKKa-48-6 | 9K16 | Nov. 14, 2012 | Nov. 13, 2013 |
| Trilog Broadband Antenna SCHWARZBECK | VULB 9168 | 9168-360 | Apr. 09, 2012 | Apr. 08, 2013 |
| Horn_Antenna AISI | AIH.8018 | 0000320091110 | Nov. 19, 2012 | Nov. 18, 2013 |
| Horn_Antenna SCHWARZBECK | BBHA 9170 | 9170-424 | Oct. 12, 2012 | Oct. 11, 2013 |
| RF Cable | NA | RF104-201 RF104-203 RF104-204 | Dec. 25, 2012 | Dec. 24, 2013 |
| RF Cable | NA | CHGCAB_001 | Oct. 06, 2012 | Oct. 05, 2013 |
| Software | ADT_Radiated _V8.7.05 | NA | NA | NA |
| Antenna Tower & Turn Table CT | NA | NA | NA | NA |

Note:

1. The calibration interval of the above test instruments is 12 months and the calibrations are traceable to NML/ROC and NIST/USA.
2. The horn antenna, preamplifier (model: 8449B) are used only for the measurement of emission frequency above 1GHz if tested.
- 3 The test was performed in 966 Chamber No. G.
4. The FCC Site Registration No. is 966073.
- 5 The VCCI Site Registration No. is G-137.
- 6 The CANADA Site Registration No. is IC 7450H-2.
- 7 Tested Date: Feb. 19, 2013

4.2.4 TEST PROCEDURES

- a. The EUT was placed on the top of a rotating table 0.8 meters above the ground at 3 meter chamber room for test. The table was rotated 360 degrees to determine the position of the highest radiation.
- b. The EUT was set 3 meters away from the interference-receiving antenna, which was mounted on the top of a variable-height antenna tower.
- c. The height of antenna is varied from one meter to four meters above the ground to determine the maximum value of the field strength. Both horizontal and vertical polarizations of the antenna are set to make the measurement.
- d. For each suspected emission, the EUT was arranged to its worst case and then the antenna was tuned to heights from 1 meter to 4 meters and the rotatable table was turned from 0 degrees to 360 degrees to find the maximum reading.
- e. The test-receiver system was set to quasi-peak detect function and specified bandwidth with maximum hold mode when the test frequency is below 1 GHz.
- f. The test-receiver system was set to peak and average detect function and specified bandwidth with maximum hold mode when the test frequency is above 1 GHz. If the peak reading value also meets average limit, measurement with the average detector is unnecessary.

NOTE:

1. The resolution bandwidth and video bandwidth of test receiver/spectrum analyzer is 120kHz for Quasi-peak detection (QP) at frequency below 1GHz.
2. The resolution bandwidth of test receiver/spectrum analyzer is 1 MHz and the video bandwidth is 3 MHz for Peak detection (PK) at frequency above 1GHz.
3. The resolution bandwidth of test receiver/spectrum analyzer is 1 MHz and the video bandwidth is 10 Hz for Average detection (AV) at frequency above 1GHz.
4. All modes of operation were investigated and the worst-case emissions are reported.

4.2.5 DEVIATION FROM TEST STANDARD

No deviation

4.2.6 TEST SETUP

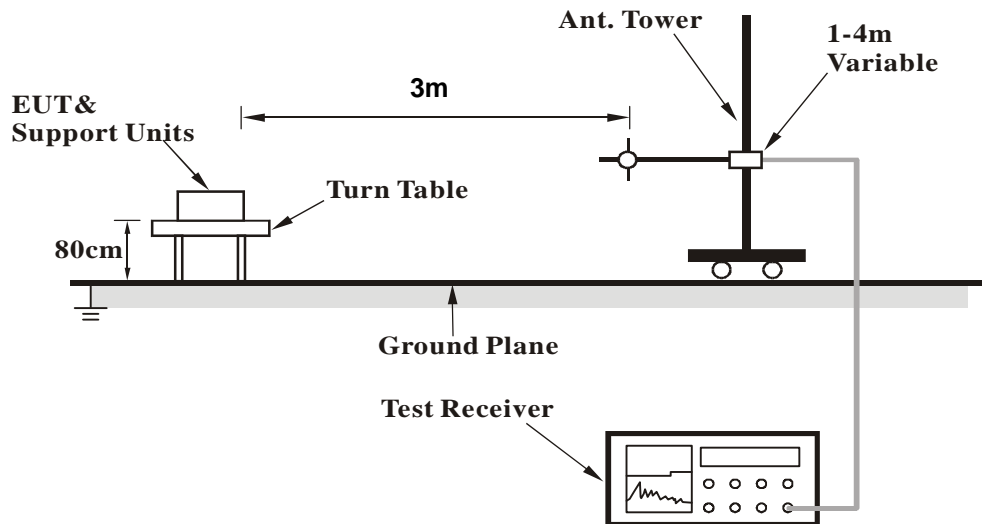

For the actual test configuration, please refer to the related item – Photographs of the Test Configuration.

4.2.7 EUT OPERATING CONDITION

Same as 4.1.6



4.2.8 TEST RESULTS

BELOW 1GHz WORST-CASE DATA

802.11a

| | | | |
|------------------------|---------------|--------------------------|-----------------|
| CHANNEL | TX Channel 36 | DETECTOR FUNCTION | Quasi-Peak (QP) |
| FREQUENCY RANGE | Below 1GHz | | |

ANTENNA POLARITY & TEST DISTANCE: HORIZONTAL AT 3 M

| NO. | FREQ. (MHz) | EMISSION LEVEL (dBuV/m) | LIMIT (dBuV/m) | MARGIN (dB) | ANTENNA HEIGHT (m) | TABLE ANGLE (Degree) | RAW VALUE (dBuV) | CORRECTION FACTOR (dB/m) |
|-----|-------------|-------------------------|----------------|-------------|--------------------|----------------------|------------------|--------------------------|
| 1 | 55.75 | 28.8 QP | 40.0 | -11.2 | 1.10 H | 65 | 14.94 | 13.84 |
| 2 | 160.00 | 32.4 QP | 43.5 | -11.1 | 1.54 H | 124 | 18.08 | 14.33 |
| 3 | 187.02 | 35.4 QP | 43.5 | -8.1 | 1.78 H | 301 | 23.08 | 12.33 |
| 4 | 214.71 | 32.7 QP | 43.5 | -10.8 | 1.35 H | 124 | 20.86 | 11.80 |
| 5 | 291.30 | 32.3 QP | 46.0 | -13.7 | 1.45 H | 98 | 17.32 | 14.95 |
| 6 | 500.01 | 32.0 QP | 46.0 | -14.0 | 1.35 H | 301 | 11.63 | 20.39 |

ANTENNA POLARITY & TEST DISTANCE: VERTICAL AT 3 M

| NO. | FREQ. (MHz) | EMISSION LEVEL (dBuV/m) | LIMIT (dBuV/m) | MARGIN (dB) | ANTENNA HEIGHT (m) | TABLE ANGLE (Degree) | RAW VALUE (dBuV) | CORRECTION FACTOR (dB/m) |
|-----|-------------|-------------------------|----------------|-------------|--------------------|----------------------|------------------|--------------------------|
| 1 | 37.25 | 31.8 QP | 40.0 | -8.2 | 1.10 V | 301 | 18.37 | 13.41 |
| 2 | 96.00 | 31.1 QP | 43.5 | -12.4 | 1.47 V | 210 | 21.73 | 9.37 |
| 3 | 187.41 | 31.5 QP | 43.5 | -12.0 | 1.07 V | 42 | 19.25 | 12.29 |
| 4 | 217.00 | 32.2 QP | 46.0 | -13.8 | 1.42 V | 35 | 20.31 | 11.90 |
| 5 | 624.45 | 28.2 QP | 46.0 | -17.8 | 1.41 V | 300 | 5.24 | 22.97 |
| 6 | 750.00 | 29.3 QP | 46.0 | -16.7 | 1.34 V | 215 | 4.40 | 24.91 |

REMARKS:

1. Emission level (dBuV/m) = Raw Value (dBuV) + Correction Factor (dB/m).
2. Correction Factor (dB/m) = Antenna Factor (dB/m) + Cable Factor (dB).
3. The other emission levels were very low against the limit.
4. Margin value = Emission level – Limit value.



A D T

ABOVE 1GHz DATA

802.11a

| | | | |
|------------------------|---------------|--------------------------|--------------|
| CHANNEL | TX Channel 36 | DETECTOR FUNCTION | Peak (PK) |
| FREQUENCY RANGE | 1GHz ~ 40GHz | | Average (AV) |

ANTENNA POLARITY & TEST DISTANCE: HORIZONTAL AT 3 M

| NO. | FREQ. (MHz) | EMISSION LEVEL (dBuV/m) | LIMIT (dBuV/m) | MARGIN (dB) | ANTENNA HEIGHT (m) | TABLE ANGLE (Degree) | RAW VALUE (dBuV) | CORRECTION FACTOR (dB/m) |
|-----|-------------|-------------------------|----------------|-------------|--------------------|----------------------|------------------|--------------------------|
| 1 | 5150.00 | 58.5 PK | 74.0 | -15.5 | 1.24 H | 177 | 15.93 | 42.57 |
| 2 | 5150.00 | 47.1 AV | 54.0 | -6.9 | 1.24 H | 177 | 4.53 | 42.57 |
| 3 | *5180.00 | 103.1 PK | | | 1.24 H | 177 | 60.43 | 42.67 |
| 4 | *5180.00 | 94.7 AV | | | 1.24 H | 177 | 52.03 | 42.67 |
| 5 | #10360.00 | 56.4 PK | 68.3 | -11.9 | 1.00 H | 155 | 6.99 | 49.41 |
| 6 | 15540.00 | 61.8 PK | 74.0 | -12.2 | 1.00 H | 312 | 6.35 | 55.45 |
| 7 | 15540.00 | 50.5 AV | 54.0 | -3.5 | 1.00 H | 312 | -4.95 | 55.45 |

ANTENNA POLARITY & TEST DISTANCE: VERTICAL AT 3 M

| NO. | FREQ. (MHz) | EMISSION LEVEL (dBuV/m) | LIMIT (dBuV/m) | MARGIN (dB) | ANTENNA HEIGHT (m) | TABLE ANGLE (Degree) | RAW VALUE (dBuV) | CORRECTION FACTOR (dB/m) |
|-----|-------------|-------------------------|----------------|-------------|--------------------|----------------------|------------------|--------------------------|
| 1 | 5150.00 | 70.4 PK | 74.0 | -3.6 | 1.38 V | 101 | 27.83 | 42.57 |
| 2 | 5150.00 | 53.5 AV | 54.0 | -0.5 | 1.38 V | 101 | 10.93 | 42.57 |
| 3 | *5180.00 | 108.3 PK | | | 1.38 V | 101 | 65.63 | 42.67 |
| 4 | *5180.00 | 99.6 AV | | | 1.38 V | 101 | 56.93 | 42.67 |
| 5 | #10360.00 | 56.6 PK | 68.3 | -11.7 | 1.00 V | 18 | 7.19 | 49.41 |
| 6 | 15540.00 | 61.3 PK | 74.0 | -12.7 | 1.00 V | 251 | 5.85 | 55.45 |
| 7 | 15540.00 | 50.4 AV | 54.0 | -3.6 | 1.00 V | 251 | -5.05 | 55.45 |

REMARKS:

1. Emission level (dBuV/m) = Raw Value (dBuV) + Correction Factor (dB/m).
2. Correction Factor (dB/m) = Antenna Factor (dB/m) + Cable Factor (dB).
3. The other emission levels were very low against the limit.
4. Margin value = Emission level – Limit value.
5. " * ": Fundamental frequency.
6. " # ": The radiated frequency is out of the restricted band.



A D T

| | | | |
|------------------------|---------------|--------------------------|--------------|
| CHANNEL | TX Channel 40 | DETECTOR FUNCTION | Peak (PK) |
| FREQUENCY RANGE | 1GHz ~ 40GHz | | Average (AV) |

ANTENNA POLARITY & TEST DISTANCE: HORIZONTAL AT 3 M

| NO. | FREQ. (MHz) | EMISSION LEVEL (dBuV/m) | LIMIT (dBuV/m) | MARGIN (dB) | ANTENNA HEIGHT (m) | TABLE ANGLE (Degree) | RAW VALUE (dBuV) | CORRECTION FACTOR (dB/m) |
|-----|-------------|-------------------------|----------------|-------------|--------------------|----------------------|------------------|--------------------------|
| 1 | 5119.00 | 58.0 PK | 74.0 | -16.0 | 1.28 H | 166 | 15.53 | 42.47 |
| 2 | 5119.00 | 46.7 AV | 54.0 | -7.3 | 1.28 H | 166 | 4.23 | 42.47 |
| 3 | *5200.00 | 104.2 PK | | | 1.24 H | 179 | 61.47 | 42.73 |
| 4 | *5200.00 | 94.9 AV | | | 1.24 H | 179 | 52.17 | 42.73 |
| 5 | #10400.00 | 56.3 PK | 68.3 | -12.0 | 1.00 H | 153 | 7.27 | 49.03 |
| 6 | 15600.00 | 62.0 PK | 74.0 | -12.0 | 1.00 H | 312 | 6.75 | 55.25 |
| 7 | 15600.00 | 50.6 AV | 54.0 | -3.4 | 1.00 H | 312 | -4.65 | 55.25 |

ANTENNA POLARITY & TEST DISTANCE: VERTICAL AT 3 M

| NO. | FREQ. (MHz) | EMISSION LEVEL (dBuV/m) | LIMIT (dBuV/m) | MARGIN (dB) | ANTENNA HEIGHT (m) | TABLE ANGLE (Degree) | RAW VALUE (dBuV) | CORRECTION FACTOR (dB/m) |
|-----|-------------|-------------------------|----------------|-------------|--------------------|----------------------|------------------|--------------------------|
| 1 | 5119.00 | 58.2 PK | 74.0 | -15.8 | 1.00 V | 166 | 15.73 | 42.47 |
| 2 | 5119.00 | 48.3 AV | 54.0 | -5.7 | 1.00 V | 166 | 5.83 | 42.47 |
| 3 | *5200.00 | 106.3 PK | | | 1.43 V | 92 | 63.57 | 42.73 |
| 4 | *5200.00 | 98.3 AV | | | 1.43 V | 92 | 55.57 | 42.73 |
| 5 | #10400.00 | 56.8 PK | 68.3 | -11.5 | 1.00 V | 21 | 7.77 | 49.03 |
| 6 | 15600.00 | 61.0 PK | 74.0 | -13.0 | 1.00 V | 253 | 5.75 | 55.25 |
| 7 | 15600.00 | 50.5 AV | 54.0 | -3.5 | 1.00 V | 253 | -4.75 | 55.25 |

REMARKS:

1. Emission level (dBuV/m) = Raw Value (dBuV) + Correction Factor (dB/m).
2. Correction Factor (dB/m) = Antenna Factor (dB/m) + Cable Factor (dB).
3. The other emission levels were very low against the limit.
4. Margin value = Emission level – Limit value.
5. " * ": Fundamental frequency.
6. " # ": The radiated frequency is out of the restricted band.



| | | | |
|------------------------|---------------|--------------------------|--------------|
| CHANNEL | TX Channel 48 | DETECTOR FUNCTION | Peak (PK) |
| FREQUENCY RANGE | 1GHz ~ 40GHz | | Average (AV) |

| ANTENNA POLARITY & TEST DISTANCE: HORIZONTAL AT 3 M | | | | | | | | |
|---|-------------|-------------------------|----------------|-------------|--------------------|----------------------|------------------|--------------------------|
| NO. | FREQ. (MHz) | EMISSION LEVEL (dBuV/m) | LIMIT (dBuV/m) | MARGIN (dB) | ANTENNA HEIGHT (m) | TABLE ANGLE (Degree) | RAW VALUE (dBuV) | CORRECTION FACTOR (dB/m) |
| 1 | *5240.00 | 103.4 PK | | | 1.21 H | 164 | 60.63 | 42.77 |
| 2 | *5240.00 | 95.1 AV | | | 1.21 H | 164 | 52.33 | 42.77 |
| 3 | 5350.00 | 57.2 PK | 74.0 | -16.8 | 1.21 H | 164 | 14.37 | 42.83 |
| 4 | 5350.00 | 45.1 AV | 54.0 | -8.9 | 1.21 H | 164 | 2.27 | 42.83 |
| 5 | #10480.00 | 56.1 PK | 68.3 | -12.2 | 1.03 H | 152 | 6.51 | 49.59 |
| 6 | 15720.00 | 61.9 PK | 74.0 | -12.1 | 1.06 H | 311 | 7.06 | 54.84 |
| 7 | 15720.00 | 50.7 AV | 54.0 | -3.3 | 1.06 H | 311 | -4.14 | 54.84 |

| ANTENNA POLARITY & TEST DISTANCE: VERTICAL AT 3 M | | | | | | | | |
|---|-------------|-------------------------|----------------|-------------|--------------------|----------------------|------------------|--------------------------|
| NO. | FREQ. (MHz) | EMISSION LEVEL (dBuV/m) | LIMIT (dBuV/m) | MARGIN (dB) | ANTENNA HEIGHT (m) | TABLE ANGLE (Degree) | RAW VALUE (dBuV) | CORRECTION FACTOR (dB/m) |
| 1 | *5240.00 | 108.2 PK | | | 1.30 V | 90 | 65.43 | 42.77 |
| 2 | *5240.00 | 99.9 AV | | | 1.30 V | 90 | 57.13 | 42.77 |
| 3 | 5350.00 | 57.9 PK | 74.0 | -16.1 | 1.30 V | 90 | 15.07 | 42.83 |
| 4 | 5350.00 | 45.9 AV | 54.0 | -8.1 | 1.30 V | 90 | 3.07 | 42.83 |
| 5 | #10480.00 | 56.1 PK | 68.3 | -12.2 | 1.00 V | 25 | 6.51 | 49.59 |
| 6 | 15720.00 | 61.8 PK | 74.0 | -12.2 | 1.00 V | 249 | 6.96 | 54.84 |
| 7 | 15720.00 | 50.8 AV | 54.0 | -3.2 | 1.00 V | 249 | -4.04 | 54.84 |

REMARKS:

1. Emission level (dBuV/m) = Raw Value (dBuV) + Correction Factor (dB/m).
2. Correction Factor (dB/m) = Antenna Factor (dB/m) + Cable Factor (dB).
3. The other emission levels were very low against the limit.
4. Margin value = Emission level – Limit value.
5. " * ": Fundamental frequency.
6. " # ": The radiated frequency is out of the restricted band.

802.11n (HT20)

| | | | |
|------------------------|---------------|--------------------------|--------------|
| CHANNEL | TX Channel 36 | DETECTOR FUNCTION | Peak (PK) |
| FREQUENCY RANGE | 1GHz ~ 40GHz | | Average (AV) |

| ANTENNA POLARITY & TEST DISTANCE: HORIZONTAL AT 3 M | | | | | | | | |
|---|-------------|-------------------------|----------------|-------------|--------------------|----------------------|------------------|--------------------------|
| NO. | FREQ. (MHz) | EMISSION LEVEL (dBuV/m) | LIMIT (dBuV/m) | MARGIN (dB) | ANTENNA HEIGHT (m) | TABLE ANGLE (Degree) | RAW VALUE (dBuV) | CORRECTION FACTOR (dB/m) |
| 1 | 5150.00 | 59.0 PK | 74.0 | -15.0 | 1.29 H | 179 | 16.43 | 42.57 |
| 2 | 5150.00 | 47.4 AV | 54.0 | -6.6 | 1.29 H | 179 | 4.83 | 42.57 |
| 3 | *5180.00 | 102.2 PK | | | 1.29 H | 179 | 59.53 | 42.67 |
| 4 | *5180.00 | 93.1 AV | | | 1.29 H | 179 | 50.43 | 42.67 |
| 5 | #10360.00 | 56.5 PK | 68.3 | -11.8 | 1.00 H | 160 | 7.09 | 49.41 |
| 6 | 15540.00 | 61.6 PK | 74.0 | -12.4 | 1.05 H | 312 | 6.15 | 55.45 |
| 7 | 15540.00 | 50.5 AV | 54.0 | -3.5 | 1.05 H | 312 | -4.95 | 55.45 |

| ANTENNA POLARITY & TEST DISTANCE: VERTICAL AT 3 M | | | | | | | | |
|---|-------------|-------------------------|----------------|-------------|--------------------|----------------------|------------------|--------------------------|
| NO. | FREQ. (MHz) | EMISSION LEVEL (dBuV/m) | LIMIT (dBuV/m) | MARGIN (dB) | ANTENNA HEIGHT (m) | TABLE ANGLE (Degree) | RAW VALUE (dBuV) | CORRECTION FACTOR (dB/m) |
| 1 | 5150.00 | 71.1 PK | 74.0 | -2.9 | 1.37 V | 101 | 28.53 | 42.57 |
| 2 | 5150.00 | 53.0 AV | 54.0 | -1.0 | 1.37 V | 101 | 10.43 | 42.57 |
| 3 | *5180.00 | 106.8 PK | | | 1.30 V | 78 | 64.13 | 42.67 |
| 4 | *5180.00 | 97.1 AV | | | 1.30 V | 78 | 54.43 | 42.67 |
| 5 | #10360.00 | 56.4 PK | 68.3 | -11.9 | 1.00 V | 22 | 6.99 | 49.41 |
| 6 | 15540.00 | 61.0 PK | 74.0 | -13.0 | 1.01 V | 251 | 5.55 | 55.45 |
| 7 | 15540.00 | 50.3 AV | 54.0 | -3.7 | 1.01 V | 251 | -5.15 | 55.45 |

REMARKS:

1. Emission level (dBuV/m) = Raw Value (dBuV) + Correction Factor (dB/m).
2. Correction Factor (dB/m) = Antenna Factor (dB/m) + Cable Factor (dB).
3. The other emission levels were very low against the limit.
4. Margin value = Emission level – Limit value.
5. " * ": Fundamental frequency.
6. " # ": The radiated frequency is out of the restricted band.



A D T

| | | | |
|------------------------|---------------|--------------------------|--------------|
| CHANNEL | TX Channel 40 | DETECTOR FUNCTION | Peak (PK) |
| FREQUENCY RANGE | 1GHz ~ 40GHz | | Average (AV) |

ANTENNA POLARITY & TEST DISTANCE: HORIZONTAL AT 3 M

| NO. | FREQ. (MHz) | EMISSION LEVEL (dBuV/m) | LIMIT (dBuV/m) | MARGIN (dB) | ANTENNA HEIGHT (m) | TABLE ANGLE (Degree) | RAW VALUE (dBuV) | CORRECTION FACTOR (dB/m) |
|-----|-------------|-------------------------|----------------|-------------|--------------------|----------------------|------------------|--------------------------|
| 1 | 5119.00 | 56.2 PK | 74.0 | -17.8 | 1.24 H | 165 | 13.73 | 42.47 |
| 2 | 5119.00 | 45.4 AV | 54.0 | -8.6 | 1.24 H | 165 | 2.93 | 42.47 |
| 3 | *5200.00 | 102.5 PK | | | 1.24 H | 165 | 59.77 | 42.73 |
| 4 | *5200.00 | 93.4 AV | | | 1.24 H | 165 | 50.67 | 42.73 |
| 5 | #10400.00 | 55.9 PK | 68.3 | -12.4 | 1.00 H | 161 | 6.87 | 49.03 |
| 6 | 15600.00 | 61.6 PK | 74.0 | -12.4 | 1.10 H | 300 | 6.35 | 55.25 |
| 7 | 15600.00 | 50.3 AV | 54.0 | -3.7 | 1.10 H | 300 | -4.95 | 55.25 |

ANTENNA POLARITY & TEST DISTANCE: VERTICAL AT 3 M

| NO. | FREQ. (MHz) | EMISSION LEVEL (dBuV/m) | LIMIT (dBuV/m) | MARGIN (dB) | ANTENNA HEIGHT (m) | TABLE ANGLE (Degree) | RAW VALUE (dBuV) | CORRECTION FACTOR (dB/m) |
|-----|-------------|-------------------------|----------------|-------------|--------------------|----------------------|------------------|--------------------------|
| 1 | 5119.00 | 57.9 PK | 74.0 | -16.1 | 1.00 V | 166 | 15.43 | 42.47 |
| 2 | 5119.00 | 48.6 AV | 54.0 | -5.4 | 1.00 V | 166 | 6.13 | 42.47 |
| 3 | *5200.00 | 106.3 PK | | | 1.31 V | 98 | 63.57 | 42.73 |
| 4 | *5200.00 | 97.6 AV | | | 1.31 V | 98 | 54.87 | 42.73 |
| 5 | #10400.00 | 56.2 PK | 68.3 | -12.1 | 1.00 V | 23 | 7.17 | 49.03 |
| 6 | 15600.00 | 61.3 PK | 74.0 | -12.7 | 1.00 V | 255 | 6.05 | 55.25 |
| 7 | 15600.00 | 50.3 AV | 54.0 | -3.7 | 1.00 V | 255 | -4.95 | 55.25 |

REMARKS:

1. Emission level (dBuV/m) = Raw Value (dBuV) + Correction Factor (dB/m).
2. Correction Factor (dB/m) = Antenna Factor (dB/m) + Cable Factor (dB).
3. The other emission levels were very low against the limit.
4. Margin value = Emission level – Limit value.
5. " * ": Fundamental frequency.
6. " # ": The radiated frequency is out of the restricted band.



A D T

| | | | |
|------------------------|---------------|--------------------------|--------------|
| CHANNEL | TX Channel 48 | DETECTOR FUNCTION | Peak (PK) |
| FREQUENCY RANGE | 1GHz ~ 40GHz | | Average (AV) |

ANTENNA POLARITY & TEST DISTANCE: HORIZONTAL AT 3 M

| NO. | FREQ. (MHz) | EMISSION LEVEL (dBuV/m) | LIMIT (dBuV/m) | MARGIN (dB) | ANTENNA HEIGHT (m) | TABLE ANGLE (Degree) | RAW VALUE (dBuV) | CORRECTION FACTOR (dB/m) |
|-----|-------------|-------------------------|----------------|-------------|--------------------|----------------------|------------------|--------------------------|
| 1 | *5240.00 | 103.2 PK | | | 1.24 H | 169 | 60.43 | 42.77 |
| 2 | *5240.00 | 94.1 AV | | | 1.24 H | 169 | 51.33 | 42.77 |
| 3 | 5350.00 | 56.6 PK | 74.0 | -17.4 | 1.29 H | 167 | 13.77 | 42.83 |
| 4 | 5350.00 | 45.6 AV | 54.0 | -8.4 | 1.29 H | 167 | 2.77 | 42.83 |
| 5 | #10480.00 | 56.2 PK | 68.3 | -12.1 | 1.00 H | 149 | 6.61 | 49.59 |
| 6 | 15720.00 | 61.9 PK | 74.0 | -12.1 | 1.10 H | 291 | 7.06 | 54.84 |
| 7 | 15720.00 | 50.5 AV | 54.0 | -3.5 | 1.10 H | 291 | -4.34 | 54.84 |

ANTENNA POLARITY & TEST DISTANCE: VERTICAL AT 3 M

| NO. | FREQ. (MHz) | EMISSION LEVEL (dBuV/m) | LIMIT (dBuV/m) | MARGIN (dB) | ANTENNA HEIGHT (m) | TABLE ANGLE (Degree) | RAW VALUE (dBuV) | CORRECTION FACTOR (dB/m) |
|-----|-------------|-------------------------|----------------|-------------|--------------------|----------------------|------------------|--------------------------|
| 1 | *5240.00 | 107.8 PK | | | 1.30 V | 90 | 65.03 | 42.77 |
| 2 | *5240.00 | 98.9 AV | | | 1.30 V | 90 | 56.13 | 42.77 |
| 3 | 5350.00 | 58.5 PK | 74.0 | -15.5 | 1.30 V | 90 | 15.67 | 42.83 |
| 4 | 5350.00 | 46.2 AV | 54.0 | -7.8 | 1.30 V | 90 | 3.37 | 42.83 |
| 5 | #10480.00 | 56.8 PK | 68.3 | -11.5 | 1.00 V | 22 | 7.21 | 49.59 |
| 6 | 15720.00 | 61.5 PK | 74.0 | -12.5 | 1.00 V | 253 | 6.66 | 54.84 |
| 7 | 15720.00 | 50.6 AV | 54.0 | -3.4 | 1.00 V | 253 | -4.24 | 54.84 |

REMARKS:

1. Emission level (dBuV/m) = Raw Value (dBuV) + Correction Factor (dB/m).
2. Correction Factor (dB/m) = Antenna Factor (dB/m) + Cable Factor (dB).
3. The other emission levels were very low against the limit.
4. Margin value = Emission level – Limit value.
5. " * ": Fundamental frequency.
6. " # ": The radiated frequency is out of the restricted band.



A D T

802.11n (HT40)

| | | | |
|------------------------|---------------|--------------------------|--------------|
| CHANNEL | TX Channel 38 | DETECTOR FUNCTION | Peak (PK) |
| FREQUENCY RANGE | 1GHz ~ 40GHz | | Average (AV) |

ANTENNA POLARITY & TEST DISTANCE: HORIZONTAL AT 3 M

| NO. | FREQ. (MHz) | EMISSION LEVEL (dBuV/m) | LIMIT (dBuV/m) | MARGIN (dB) | ANTENNA HEIGHT (m) | TABLE ANGLE (Degree) | RAW VALUE (dBuV) | CORRECTION FACTOR (dB/m) |
|-----|-------------|-------------------------|----------------|-------------|--------------------|----------------------|------------------|--------------------------|
| 1 | 5150.00 | 57.8 PK | 74.0 | -16.2 | 1.32 H | 162 | 15.23 | 42.57 |
| 2 | 5150.00 | 47.2 AV | 54.0 | -6.8 | 1.32 H | 162 | 4.63 | 42.57 |
| 3 | *5190.00 | 97.9 PK | | | 1.23 H | 162 | 55.20 | 42.70 |
| 4 | *5190.00 | 88.1 AV | | | 1.23 H | 162 | 45.40 | 42.70 |
| 5 | #10380.00 | 56.6 PK | 68.3 | -11.7 | 1.00 H | 151 | 7.38 | 49.22 |
| 6 | 15570.00 | 61.9 PK | 74.0 | -12.1 | 1.15 H | 301 | 6.55 | 55.35 |
| 7 | 15570.00 | 50.5 AV | 54.0 | -3.5 | 1.15 H | 301 | -4.85 | 55.35 |

ANTENNA POLARITY & TEST DISTANCE: VERTICAL AT 3 M

| NO. | FREQ. (MHz) | EMISSION LEVEL (dBuV/m) | LIMIT (dBuV/m) | MARGIN (dB) | ANTENNA HEIGHT (m) | TABLE ANGLE (Degree) | RAW VALUE (dBuV) | CORRECTION FACTOR (dB/m) |
|-----|-------------|-------------------------|----------------|-------------|--------------------|----------------------|------------------|--------------------------|
| 1 | 5150.00 | 66.2 PK | 74.0 | -7.8 | 1.39 V | 93 | 23.63 | 42.57 |
| 2 | 5150.00 | 52.8 AV | 54.0 | -1.2 | 1.39 V | 93 | 10.23 | 42.57 |
| 3 | *5190.00 | 102.2 PK | | | 1.39 V | 93 | 59.50 | 42.70 |
| 4 | *5190.00 | 92.1 AV | | | 1.39 V | 93 | 49.40 | 42.70 |
| 5 | #10380.00 | 57.0 PK | 68.3 | -11.3 | 1.03 V | 34 | 7.78 | 49.22 |
| 6 | 15570.00 | 61.5 PK | 74.0 | -12.5 | 1.00 V | 246 | 6.15 | 55.35 |
| 7 | 15570.00 | 50.8 AV | 54.0 | -3.2 | 1.00 V | 246 | -4.55 | 55.35 |

REMARKS:

1. Emission level (dBuV/m) = Raw Value (dBuV) + Correction Factor (dB/m).
2. Correction Factor (dB/m) = Antenna Factor (dB/m) + Cable Factor (dB).
3. The other emission levels were very low against the limit.
4. Margin value = Emission level – Limit value.
5. " * ": Fundamental frequency.
6. " # ": The radiated frequency is out of the restricted band.



A D T

| | | | |
|------------------------|---------------|--------------------------|--------------|
| CHANNEL | TX Channel 46 | DETECTOR FUNCTION | Peak (PK) |
| FREQUENCY RANGE | 1GHz ~ 40GHz | | Average (AV) |

| ANTENNA POLARITY & TEST DISTANCE: HORIZONTAL AT 3 M | | | | | | | | |
|---|-------------|-------------------------|----------------|-------------|--------------------|----------------------|------------------|--------------------------|
| NO. | FREQ. (MHz) | EMISSION LEVEL (dBuV/m) | LIMIT (dBuV/m) | MARGIN (dB) | ANTENNA HEIGHT (m) | TABLE ANGLE (Degree) | RAW VALUE (dBuV) | CORRECTION FACTOR (dB/m) |
| 1 | 5119.00 | 56.9 PK | 74.0 | -17.1 | 1.35 H | 177 | 14.43 | 42.47 |
| 2 | 5119.00 | 44.8 AV | 54.0 | -9.2 | 1.35 H | 177 | 2.33 | 42.47 |
| 3 | *5230.00 | 101.6 PK | | | 1.23 H | 178 | 58.84 | 42.76 |
| 4 | *5230.00 | 91.9 AV | | | 1.23 H | 178 | 49.14 | 42.76 |
| 5 | 5350.00 | 57.2 PK | 74.0 | -16.8 | 1.38 H | 177 | 14.37 | 42.83 |
| 6 | 5350.00 | 45.1 AV | 54.0 | -8.9 | 1.38 H | 177 | 2.27 | 42.83 |
| 7 | #10460.00 | 56.9 PK | 68.3 | -11.4 | 1.00 H | 160 | 7.45 | 49.45 |
| 8 | 15690.00 | 62.2 PK | 74.0 | -11.8 | 1.17 H | 300 | 7.36 | 54.84 |
| 9 | 15690.00 | 50.8 AV | 54.0 | -3.2 | 1.17 H | 300 | -4.04 | 54.84 |

| ANTENNA POLARITY & TEST DISTANCE: VERTICAL AT 3 M | | | | | | | | |
|---|-------------|-------------------------|----------------|-------------|--------------------|----------------------|------------------|--------------------------|
| NO. | FREQ. (MHz) | EMISSION LEVEL (dBuV/m) | LIMIT (dBuV/m) | MARGIN (dB) | ANTENNA HEIGHT (m) | TABLE ANGLE (Degree) | RAW VALUE (dBuV) | CORRECTION FACTOR (dB/m) |
| 1 | 5119.00 | 56.8 PK | 74.0 | -17.2 | 1.00 V | 161 | 14.33 | 42.47 |
| 2 | 5119.00 | 47.3 AV | 54.0 | -6.7 | 1.00 V | 161 | 4.83 | 42.47 |
| 3 | *5230.00 | 105.6 PK | | | 1.36 V | 99 | 62.84 | 42.76 |
| 4 | *5230.00 | 96.5 AV | | | 1.36 V | 99 | 53.74 | 42.76 |
| 5 | 5350.00 | 58.7 PK | 74.0 | -15.3 | 1.39 V | 93 | 15.87 | 42.83 |
| 6 | 5350.00 | 46.6 AV | 54.0 | -7.4 | 1.39 V | 93 | 3.77 | 42.83 |
| 7 | #10460.00 | 57.3 PK | 68.3 | -11.0 | 1.08 V | 36 | 7.85 | 49.45 |
| 8 | 15690.00 | 61.4 PK | 74.0 | -12.6 | 1.04 V | 237 | 6.56 | 54.84 |
| 9 | 15690.00 | 50.9 AV | 54.0 | -3.1 | 1.04 V | 237 | -3.94 | 54.84 |

REMARKS:

1. Emission level (dBuV/m) = Raw Value (dBuV) + Correction Factor (dB/m).
2. Correction Factor (dB/m) = Antenna Factor (dB/m) + Cable Factor (dB).
3. The other emission levels were very low against the limit.
4. Margin value = Emission level – Limit value.
5. " * ": Fundamental frequency.
6. " # ": The radiated frequency is out of the restricted band.



A D T

802.11ac (VHT80)

| | | | |
|------------------------|---------------|--------------------------|--------------|
| CHANNEL | TX Channel 42 | DETECTOR FUNCTION | Peak (PK) |
| FREQUENCY RANGE | 1GHz ~ 40GHz | | Average (AV) |

ANTENNA POLARITY & TEST DISTANCE: HORIZONTAL AT 3 M

| NO. | FREQ. (MHz) | EMISSION LEVEL (dBuV/m) | LIMIT (dBuV/m) | MARGIN (dB) | ANTENNA HEIGHT (m) | TABLE ANGLE (Degree) | RAW VALUE (dBuV) | CORRECTION FACTOR (dB/m) |
|-----|-------------|-------------------------|----------------|-------------|--------------------|----------------------|------------------|--------------------------|
| 1 | 5150.00 | 56.8 PK | 74.0 | -17.2 | 1.32 H | 180 | 14.23 | 42.57 |
| 2 | 5150.00 | 44.9 AV | 54.0 | -9.1 | 1.32 H | 180 | 2.33 | 42.57 |
| 3 | *5210.00 | 92.1 PK | | | 1.19 H | 187 | 49.36 | 42.74 |
| 4 | *5210.00 | 82.7 AV | | | 1.19 H | 187 | 39.96 | 42.74 |
| 5 | 5350.00 | 57.3 PK | 74.0 | -16.7 | 1.42 H | 183 | 14.47 | 42.83 |
| 6 | 5350.00 | 45.3 AV | 54.0 | -8.7 | 1.42 H | 183 | 2.47 | 42.83 |
| 7 | #10420.00 | 57.0 PK | 68.3 | -11.3 | 1.00 H | 167 | 7.83 | 49.17 |
| 8 | 15630.00 | 62.4 PK | 74.0 | -11.6 | 1.14 H | 288 | 7.29 | 55.11 |
| 9 | 15630.00 | 50.7 AV | 54.0 | -3.3 | 1.14 H | 288 | -4.41 | 55.11 |

ANTENNA POLARITY & TEST DISTANCE: VERTICAL AT 3 M

| NO. | FREQ. (MHz) | EMISSION LEVEL (dBuV/m) | LIMIT (dBuV/m) | MARGIN (dB) | ANTENNA HEIGHT (m) | TABLE ANGLE (Degree) | RAW VALUE (dBuV) | CORRECTION FACTOR (dB/m) |
|-----|----------------|-------------------------|----------------|-------------|--------------------|----------------------|------------------|--------------------------|
| 1 | 5150.00 | 66.5 PK | 74.0 | -7.5 | 1.39 V | 94 | 23.93 | 42.57 |
| 2 | 5150.00 | 53.5 AV | 54.0 | -0.5 | 1.39 V | 94 | 10.93 | 42.57 |
| 3 | *5210.00 | 96.6 PK | | | 1.39 V | 94 | 53.86 | 42.74 |
| 4 | *5210.00 | 87.8 AV | | | 1.39 V | 94 | 45.06 | 42.74 |
| 5 | 5350.00 | 58.9 PK | 74.0 | -15.1 | 1.39 V | 94 | 16.07 | 42.83 |
| 6 | 5350.00 | 46.4 AV | 54.0 | -7.6 | 1.39 V | 94 | 3.57 | 42.83 |
| 7 | #10420.00 | 57.2 PK | 68.3 | -11.1 | 1.09 V | 51 | 8.03 | 49.17 |
| 8 | 15630.00 | 61.0 PK | 74.0 | -13.0 | 1.01 V | 248 | 5.89 | 55.11 |
| 9 | 15630.00 | 50.7 AV | 54.0 | -3.3 | 1.01 V | 248 | -4.41 | 55.11 |

REMARKS:

1. Emission level (dBuV/m) = Raw Value (dBuV) + Correction Factor (dB/m).
2. Correction Factor (dB/m) = Antenna Factor (dB/m) + Cable Factor (dB).
3. The other emission levels were very low against the limit.
4. Margin value = Emission level – Limit value.
5. " * ": Fundamental frequency.
6. " # ": The radiated frequency is out of the restricted band.



A D T

4.3 TRANSMIT POWER MEASUREMENT

4.3.1 LIMITS OF TRANSMIT POWER MEASUREMENT

| Frequency Band | Limit |
|------------------|---|
| 5.15 – 5.25GHz | The lesser of 50mW (17dBm) or 4dBm + 10logB |
| 5.25 – 5.35GHz | The lesser of 250mW (24dBm) or 11dBm + 10logB |
| 5.47 – 5.725GHz | The lesser of 250mW (24dBm) or 11dBm + 10logB |
| 5.725 – 5.825GHz | The lesser of 1W (30dBm) or 17dBm + 10logB |

NOTE: Where B is the 26dB emission bandwidth in MHz.

Per KDB 662911 D01 Multiple Transmitter Output v01r02 Method of conducted output power measurement on IEEE 802.11 devices,

Array Gain = 0 dB (i.e., no array gain) for NANT ≤ 4;

Array Gain = 0 dB (i.e., no array gain) for channel widths ≥ 40 MHz for any NANT;

Array Gain = 5 log(NANT/NSS) dB or 3 dB, whichever is less for 20-MHz channel widths with NANT ≥ 5.

For power measurements on all other devices: Array Gain = 10 log(NANT/NSS) dB.

4.3.2 TEST INSTRUMENTS

FOR POWER OUTPUT MEASUREMENT (802.11a, 802.11n (HT20), 802.11n (HT40))

| DESCRIPTION & MANUFACTURER | MODEL NO. | SERIAL NO. | CALIBRATED DATE | CALIBRATED UNTIL |
|----------------------------|-----------|------------|-----------------|------------------|
| Power Meter | ML2495A | 0824006 | May 10, 2012 | May 09, 2013 |
| Power Sensor | MA2411B | 0738172 | May 10, 2012 | May 09, 2013 |

Note:

1. The calibration interval of the above test instruments is 12 months and the calibrations are traceable to NML/ROC and NIST/USA.
2. Tested date : Feb. 18, 2013



A D T

FOR POWER OUTPUT MEASUREMENT (802.11ac (VHT80))

| DESCRIPTION & MANUFACTURER | MODEL NO. | SERIAL NO. | CALIBRATED DATE | CALIBRATED UNTIL |
|----------------------------|-----------|------------|-----------------|------------------|
| R&S Spectrum Analyzer | FSP40 | 100037 | Nov. 01, 2012 | Oct. 31, 2013 |

Note:

1. The calibration interval of the above test instruments is 12 months and the calibrations are traceable to NML/ROC and NIST/USA.
2. Tested date : Feb. 18, 2013

FOR 99% OCCUPIED BANDWIDTH

| DESCRIPTION & MANUFACTURER | MODEL NO. | SERIAL NO. | CALIBRATED DATE | CALIBRATED UNTIL |
|----------------------------|-----------|------------|-----------------|------------------|
| R&S Spectrum Analyzer | FSP40 | 100037 | Nov. 01, 2012 | Oct. 31, 2013 |

Note:

1. The calibration interval of the above test instruments is 12 months and the calibrations are traceable to NML/ROC and NIST/USA.
2. Tested date : Feb. 18, 2013

4.3.3 TEST PROCEDURE

FOR POWER OUTPUT MEASUREMENT (802.11a, 802.11n (HT20), 802.11n (HT40))

Method PM is used to perform output power measurement, trigger and gating function of wide band power meter is enabled to measure max output power of TX on burst. Duty factor is not added to measured value.

FOR POWER OUTPUT MEASUREMENT (802.11ac (VHT80))

1. Set span to encompass the entire emission bandwidth (EBW) of the signal.
2. Set RBW = 1MHz.
3. Set the VBW $\geq 3 \times$ RBW.
4. Number of points in sweep ≥ 2 Span / RBW.
5. Sweep time = auto.
6. Set trigger to free run (duty cycle ≥ 98 percent) ; Set video trigger (duty cycle < 98 percent)
7. Detector = RMS.
8. Trace average at least 100 traces in power averaging mode
9. Compute power by integrating the spectrum across the 26 dB EBW of the signal.

FOR 99% OCCUPIED BANDWIDTH

1. Set RBW \geq 1% of the emission bandwidth.
2. Set the VBW \geq 3 \times RBW.
3. Detector = Peak.
4. Trace mode = max hold.
5. Record the 99% emission bandwidth.

4.3.4 DEVIATION FROM TEST STANDARD

No deviation

4.3.5 TEST SETUP

FOR POWER OUTPUT MEASUREMENT (802.11a, 802.11n (HT20), 802.11n (HT40))

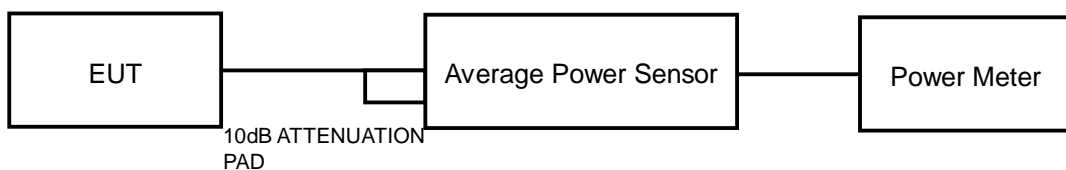

FOR POWER OUTPUT MEASUREMENT (802.11ac (VHT80))

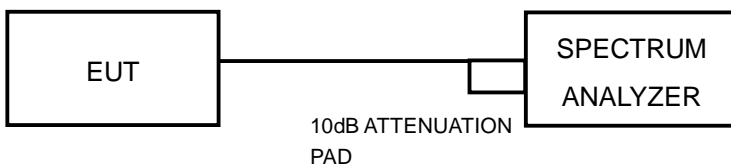

FOR 99% OCCUPIED BANDWIDTH

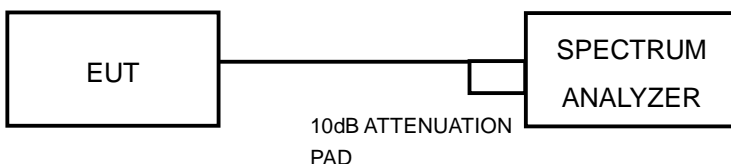

4.3.6 EUT OPERATING CONDITIONS

The software provided by client to enable the EUT under transmission condition continuously at specific channel frequencies individually.



A D T

4.3.7 TEST RESULTS

POWER OUTPUT:

802.11a

| CHAN. | CHAN. FREQ. (MHz) | AVERAGE POWER (dBm) | | TOTAL POWER (mW) | TOTAL POWER (dBm) | POWER LIMIT (dBm) | PASS / FAIL |
|-------|-------------------|---------------------|---------|------------------|-------------------|-------------------|-------------|
| | | CHAIN 0 | CHAIN 1 | | | | |
| 36 | 5180 | 13.60 | 13.70 | 46.351 | 16.66 | 17 | PASS |
| 40 | 5200 | 13.40 | 13.50 | 44.265 | 16.46 | 17 | PASS |
| 48 | 5240 | 13.60 | 13.50 | 45.296 | 16.56 | 17 | PASS |

802.11n (HT20)

| CHAN. | CHAN. FREQ. (MHz) | AVERAGE POWER (dBm) | | TOTAL POWER (mW) | TOTAL POWER (dBm) | POWER LIMIT (dBm) | PASS / FAIL |
|-------|-------------------|---------------------|---------|------------------|-------------------|-------------------|-------------|
| | | CHAIN 0 | CHAIN 1 | | | | |
| 36 | 5180 | 13.60 | 13.50 | 45.296 | 16.56 | 17 | PASS |
| 40 | 5200 | 13.30 | 13.50 | 43.767 | 16.41 | 17 | PASS |
| 48 | 5240 | 13.40 | 13.40 | 43.756 | 16.41 | 17 | PASS |

802.11n (HT40)

| CHAN. | CHAN. FREQ. (MHz) | AVERAGE POWER (dBm) | | TOTAL POWER (mW) | TOTAL POWER (dBm) | POWER LIMIT (dBm) | PASS / FAIL |
|-------|-------------------|---------------------|---------|------------------|-------------------|-------------------|-------------|
| | | CHAIN 0 | CHAIN 1 | | | | |
| 38 | 5190 | 13.50 | 13.30 | 43.767 | 16.41 | 17 | PASS |
| 46 | 5230 | 13.30 | 13.50 | 43.767 | 16.41 | 17 | PASS |

802.11ac (VHT80)

| CHAN. | CHAN. FREQ. (MHz) | AVERAGE POWER (dBm) | | TOTAL POWER (mW) | TOTAL POWER (dBm) | POWER LIMIT (dBm) | PASS / FAIL |
|-------|-------------------|---------------------|---------|------------------|-------------------|-------------------|-------------|
| | | CHAIN 0 | CHAIN 1 | | | | |
| 42 | 5210 | 11.48 | 11.67 | 28.749 | 14.59 | 17 | PASS |



A D T

26dB OCCUPIED BANDWIDTH:

802.11a

| CHANNEL | CHANNEL FREQUENCY (MHz) | 26dBc BANDWIDTH (MHz) | |
|---------|-------------------------|-----------------------|---------|
| | | CHAIN 0 | CHAIN 1 |
| 36 | 5180 | 19.53 | 19.55 |
| 40 | 5200 | 19.40 | 19.53 |
| 48 | 5240 | 19.37 | 19.29 |

802.11n (HT20)

| CHANNEL | CHANNEL FREQUENCY (MHz) | 26dBc BANDWIDTH (MHz) | |
|---------|-------------------------|-----------------------|---------|
| | | CHAIN 0 | CHAIN 1 |
| 36 | 5180 | 19.97 | 19.95 |
| 40 | 5200 | 20.01 | 20.01 |
| 48 | 5240 | 20.01 | 19.95 |

802.11n (HT40)

| CHANNEL | CHANNEL FREQUENCY (MHz) | 26dBc BANDWIDTH (MHz) | |
|---------|-------------------------|-----------------------|---------|
| | | CHAIN 0 | CHAIN 1 |
| 38 | 5190 | 43.19 | 43.33 |
| 46 | 5230 | 43.24 | 43.33 |

802.11ac (VHT80)

| CHANNEL | CHANNEL FREQUENCY (MHz) | 26dBc BANDWIDTH (MHz) | |
|---------|-------------------------|-----------------------|---------|
| | | CHAIN 0 | CHAIN 1 |
| 42 | 5210 | 83.89 | 83.97 |



A D T

4.4 PEAK POWER SPECTRAL DENSITY MEASUREMENT

4.4.1 LIMITS OF PEAK POWER SPECTRAL DENSITY MEASUREMENT

| Frequency Band | Limit |
|------------------|-------|
| 5.15 ~ 5.25GHz | 4dBm |
| 5.25 ~ 5.35GHz | 11dBm |
| 5.47 ~ 5.725GHz | 11dBm |
| 5.725 ~ 5.825GHz | 17dBm |

4.4.2 TEST INSTRUMENTS

| DESCRIPTION & MANUFACTURER | MODEL NO. | SERIAL NO. | CALIBRATED DATE | CALIBRATED UNTIL |
|----------------------------|-----------|------------|-----------------|------------------|
| R&S Spectrum Analyzer | FSP40 | 100037 | Nov. 01, 2012 | Oct. 31, 2013 |

Note:

1. The calibration interval of the above test instruments is 12 months and the calibrations are traceable to NML/ROC and NIST/USA.
2. Tested date : Feb. 18, 2013

4.4.3 TEST PROCEDURES

Using method SA-1

1. Set span to encompass the entire emission bandwidth (EBW) of the signal.
2. Set RBW = 1 MHz, Set VBW \geq 3 MHz, Detector = RMS
3. Sweep time = auto, trigger set to "free run".
4. Trace average at least 100 traces in power averaging mode.
5. Record the max value

4.4.4 DEVIATION FROM TEST STANDARD

No deviation

4.4.5 TEST SETUP

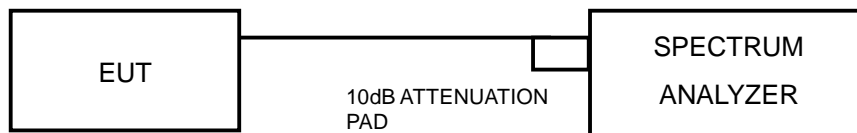

4.4.6 EUT OPERATING CONDITIONS

Same as 4.3.6



4.4.7 TEST RESULTS

802.11a

| CHAN. | CHAN. FREQ. (MHz) | PSD (dBm) | | TOTAL POWER DENSITY (dBm) | MAX. LIMIT (dBm) | PASS / FAIL |
|-------|-------------------|-----------|---------|---------------------------|------------------|-------------|
| | | CHAIN 0 | CHAIN 1 | | | |
| 36 | 5180 | 1.12 | 0.27 | 3.73 | 4 | PASS |
| 40 | 5200 | 0.83 | 0.18 | 3.53 | 4 | PASS |
| 48 | 5240 | 0.70 | 0.12 | 3.43 | 4 | PASS |

- NOTE:**
1. Method 1 of power density measurement of KDB 662911 is using for calculating total power density. Total power density is summing entire spectra across corresponding frequency bins on the various outputs by computer.
 2. Directional gain = $2\text{dBi} + 10\log(2) = 5.26\text{dBi} < 6\text{dBi}$, so the power density limit shall not be reduced.

802.11n (HT20)

| CHAN. | CHAN. FREQ. (MHz) | PSD (dBm) | | TOTAL POWER DENSITY (dBm) | MAX. LIMIT (dBm) | PASS / FAIL |
|-------|-------------------|-----------|---------|---------------------------|------------------|-------------|
| | | CHAIN 0 | CHAIN 1 | | | |
| 36 | 5180 | 0.14 | 0.58 | 3.38 | 4 | PASS |
| 40 | 5200 | -0.16 | 0.24 | 3.05 | 4 | PASS |
| 48 | 5240 | 0.06 | -0.57 | 2.77 | 4 | PASS |

- NOTE:**
1. Method 1 of power density measurement of KDB 662911 is using for calculating total power density. Total power density is summing entire spectra across corresponding frequency bins on the various outputs by computer.
 2. Directional gain = $2\text{dBi} + 10\log(2) = 5.26\text{dBi} < 6\text{dBi}$, so the power density limit shall not be reduced.



A D T

802.11n (HT40)

| CHAN. | CHAN. FREQ. (MHz) | PSD (dBm) | | TOTAL POWER DENSITY (dBm) | MAX. LIMIT (dBm) | PASS / FAIL |
|-------|-------------------|-----------|---------|---------------------------|------------------|-------------|
| | | CHAIN 0 | CHAIN 1 | | | |
| 38 | 5190 | -4.74 | -3.75 | -1.21 | 4 | PASS |
| 46 | 5230 | -3.87 | -3.82 | -0.83 | 4 | PASS |

- NOTE:**
1. Method 1 of power density measurement of KDB 662911 is using for calculating total power density. Total power density is summing entire spectra across corresponding frequency bins on the various outputs by computer.
 2. Directional gain = $2\text{dBi} + 10\log(2) = 5.26\text{dBi} < 6\text{dBi}$, so the power density limit shall not be reduced.

802.11ac (VHT80)

| CHAN. | CHAN. FREQ. (MHz) | PSD (dBm) | | TOTAL POWER DENSITY (dBm) | MAX. LIMIT (dBm) | PASS / FAIL |
|-------|-------------------|-----------|---------|---------------------------|------------------|-------------|
| | | CHAIN 0 | CHAIN 1 | | | |
| 42 | 5210 | -4.99 | -4.72 | -1.84 | 4 | PASS |

- NOTE:**
1. Method 1 of power density measurement of KDB 662911 is using for calculating total power density. Total power density is summing entire spectra across corresponding frequency bins on the various outputs by computer.
 2. Directional gain = $2\text{dBi} + 10\log(2) = 5.26\text{dBi} < 6\text{dBi}$, so the power density limit shall not be reduced.

4.5 PEAK POWER EXCURSION MEASUREMENT

4.5.1 LIMITS OF PEAK POWER EXCURSION MEASUREMENT

Shall not exceed 13 dB

4.5.2 TEST INSTRUMENTS

| DESCRIPTION & MANUFACTURER | MODEL NO. | SERIAL NO. | CALIBRATED DATE | CALIBRATED UNTIL |
|----------------------------|-----------|------------|-----------------|------------------|
| R&S Spectrum Analyzer | FSP40 | 100037 | Nov. 01, 2012 | Oct. 31, 2013 |

Note:

1. The calibration interval of the above test instruments is 12 months and the calibrations are traceable to NML/ROC and NIST/USA.
2. Tested date : Feb. 18, 2013

4.5.3 TEST PROCEDURE

1. Set RBW = 1 MHz, VBW \geq 3 MHz, Detector = peak.
2. Trace mode = max-hold. Allow the sweeps to continue until the trace stabilizes.
3. Use the peak search function to find the peak of the spectrum.
4. Measure the PPSD.
5. Compute the ratio of the maximum of the peak-max-hold spectrum to the PPSD.

4.5.4 DEVIATION FROM TEST STANDARD

No deviation

4.5.5 TEST SETUP

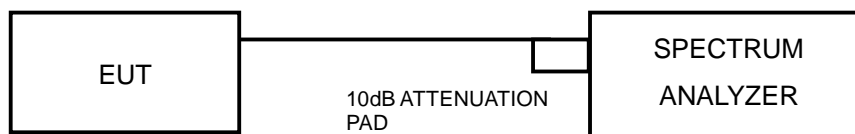

4.5.6 EUT OPERATING CONDITIONS

The software provided by client to enable the EUT under transmission condition continuously at specific channel frequencies individually.



4.5.7 TEST RESULTS

802.11a

| CHAN. | CHAN. FREQ. (MHz) | PEAK VALUE (dBm) | | PPSD (dBm) | | PEAK EXCURSION (dB) | | LIMIT (dB) | PASS/F AIL |
|-------|-------------------|------------------|---------|------------|---------|---------------------|---------|------------|------------|
| | | CHAIN 0 | CHAIN 1 | CHAIN 0 | CHAIN 1 | CHAIN 0 | CHAIN 1 | | |
| 36 | 5180 | 8.76 | 8.02 | 1.12 | 0.27 | 7.64 | 7.75 | 13 | PASS |
| 40 | 5200 | 8.51 | 8.12 | 0.83 | 0.18 | 7.68 | 7.94 | 13 | PASS |
| 48 | 5240 | 8.36 | 7.90 | 0.70 | 0.12 | 7.66 | 7.78 | 13 | PASS |

802.11n (HT20)

| CHAN. | CHAN. FREQ. (MHz) | PEAK VALUE (dBm) | | PPSD (dBm) | | PEAK EXCURSION (dB) | | LIMIT (dB) | PASS/F AIL |
|-------|-------------------|------------------|---------|------------|---------|---------------------|---------|------------|------------|
| | | CHAIN 0 | CHAIN 1 | CHAIN 0 | CHAIN 1 | CHAIN 0 | CHAIN 1 | | |
| 36 | 5180 | 7.89 | 8.30 | 0.14 | 0.58 | 7.75 | 7.72 | 13 | PASS |
| 40 | 5200 | 7.59 | 7.94 | -0.16 | 0.24 | 7.75 | 7.70 | 13 | PASS |
| 48 | 5240 | 7.92 | 7.34 | 0.06 | -0.57 | 7.86 | 7.91 | 13 | PASS |

802.11n (HT40)

| CHAN. | CHAN. FREQ. (MHz) | PEAK VALUE (dBm) | | PPSD (dBm) | | PEAK EXCURSION (dB) | | LIMIT (dB) | PASS/F AIL |
|-------|-------------------|------------------|---------|------------|---------|---------------------|---------|------------|------------|
| | | CHAIN 0 | CHAIN 1 | CHAIN 0 | CHAIN 1 | CHAIN 0 | CHAIN 1 | | |
| 38 | 5190 | 3.27 | 4.20 | -4.74 | -3.75 | 8.01 | 7.95 | 13 | PASS |
| 46 | 5230 | 4.20 | 4.26 | -3.87 | -3.82 | 8.07 | 8.08 | 13 | PASS |

802.11ac (VHT80)

| CHAN. | CHAN. FREQ. (MHz) | PEAK VALUE (dBm) | | PPSD (dBm) | | PEAK EXCURSION (dB) | | LIMIT (dB) | PASS/F AIL |
|-------|-------------------|------------------|---------|------------|---------|---------------------|---------|------------|------------|
| | | CHAIN 0 | CHAIN 1 | CHAIN 0 | CHAIN 1 | CHAIN 0 | CHAIN 1 | | |
| 42 | 5210 | 3.32 | 3.48 | -4.99 | -4.72 | 8.31 | 8.20 | 13 | PASS |

4.6 FREQUENCY STABILITY

4.6.1 LIMITS OF FREQUENCY STABILITY MEASUREMENT

The frequency of the carrier signal shall be maintained within band of operation

4.6.2 TEST INSTRUMENTS

| DESCRIPTION & MANUFACTURER | MODEL NO. | SERIAL NO. | CALIBRATED DATE | CALIBRATED UNTIL |
|----------------------------|-----------|------------|-----------------|------------------|
| R&S Spectrum Analyzer | FSP40 | 100037 | Nov. 01, 2012 | Oct. 31, 2013 |

Note:

1. The calibration interval of the above test instruments is 12 months and the calibrations are traceable to NML/ROC and NIST/USA.
2. Tested date : Feb. 18, 2013

4.6.3 TEST PROCEDURE

1. The EUT was placed inside the environmental test chamber and powered by nominal AC voltage.
2. Turn the EUT on and couple its output to a spectrum analyzer.
3. Turn the EUT off and set the chamber to the highest temperature specified.
4. Allow sufficient time (approximately 30 min) for the temperature of the chamber to stabilize, turn the EUT on and measure the operating frequency after 2, 5, and 10 minutes.
5. Repeat step 2 and 3 with the temperature chamber set to the lowest temperature.
6. The test chamber was allowed to stabilize at +20 degree C for a minimum of 30 minutes. The supply voltage was then adjusted on the EUT from 85% to 115% and the frequency record.

4.6.4 DEVIATION FROM TEST STANDARD

No deviation

4.6.5 TEST SETUP

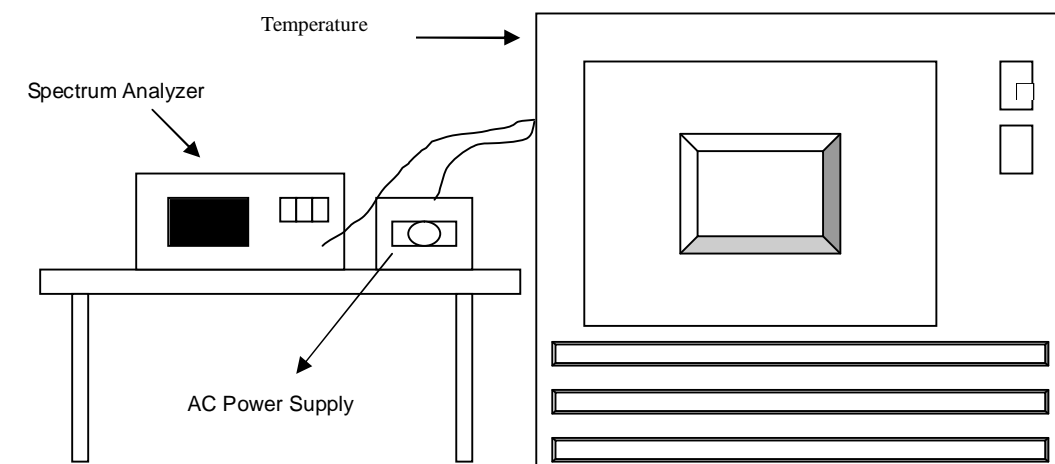

4.6.6 EUT OPERATING CONDITION

Set the EUT transmit at un-modulation mode to test frequency stability.



A D T

4.6.7 TEST RESULTS

| FREQUENCY STABILITY VERSUS TEMP. | | | | | | | | | |
|----------------------------------|--------------------------|-----------------------|--------------------|-----------------------|--------------------|-----------------------|--------------------|-----------------------|--------------------|
| OPERATING FREQUENCY: 5200MHz | | | | | | | | | |
| TEMP. (°C) | POWER SUPPLY (Vac) | 0 MINUTE | | 2 MINUTE | | 5 MINUTE | | 10 MINUTE | |
| | | Measured Frequency | Frequency Drift | Measured Frequency | Frequency Drift | Measured Frequency | Frequency Drift | Measured Frequency | Frequency Drift |
| | | (MHz) | ppm | (MHz) | ppm | (MHz) | ppm | (MHz) | ppm |
| 50 | 120 | 5200.007 | 1.3462 | 5200.0096 | 1.8462 | 5200.0029 | 0.5577 | 5200.009 | 1.7308 |
| 40 | 120 | 5199.9938 | -1.1923 | 5199.9964 | -0.6923 | 5199.9979 | -0.4038 | 5199.9899 | -1.9423 |
| 30 | 120 | 5200.0086 | 1.6538 | 5200.01 | 1.9231 | 5200.0079 | 1.5192 | 5200.0077 | 1.4808 |
| 20 | 120 | 5200.022 | 4.2308 | 5200.0227 | 4.3654 | 5200.0249 | 4.7885 | 5200.0246 | 4.7308 |
| 10 | 120 | 5200.015 | 2.8846 | 5200.0112 | 2.1538 | 5200.0105 | 2.0192 | 5200.0135 | 2.5962 |
| 0 | 120 | 5200.0202 | 3.8846 | 5200.0204 | 3.9231 | 5200.0205 | 3.9423 | 5200.0167 | 3.2115 |
| -10 | 120 | 5199.9927 | -1.4038 | 5199.9958 | -0.8077 | 5199.9927 | -1.4038 | 5199.9965 | -0.6731 |
| -20 | 120 | 5200.0035 | 0.6731 | 5200.0053 | 1.0192 | 5200.004 | 0.7692 | 5200.004 | 0.7692 |
| -30 | 120 | 5199.985 | -2.8846 | 5199.9839 | -3.0962 | 5199.9938 | -1.1923 | 5199.9912 | -1.6923 |

| FREQUENCY STABILITY VERSUS VOLTAGE | | | | | | | | | |
|------------------------------------|--------------------------|-----------------------|--------------------|-----------------------|--------------------|-----------------------|--------------------|-----------------------|--------------------|
| OPERATING FREQUENCY: 5200MHz | | | | | | | | | |
| TEMP. (°C) | POWER SUPPLY (Vac) | 0 MINUTE | | 2 MINUTE | | 5 MINUTE | | 10 MINUTE | |
| | | Measured Frequency | Frequency Drift | Measured Frequency | Frequency Drift | Measured Frequency | Frequency Drift | Measured Frequency | Frequency Drift |
| | | (MHz) | ppm | (MHz) | ppm | (MHz) | ppm | (MHz) | ppm |
| 20 | 138 | 5200.0225 | 4.3269 | 5200.0229 | 4.4038 | 5200.0238 | 4.5769 | 5200.0238 | 4.5769 |
| | 120 | 5200.022 | 4.2308 | 5200.0227 | 4.3654 | 5200.0249 | 4.7885 | 5200.0246 | 4.7308 |
| | 102 | 5200.0227 | 4.3654 | 5200.0239 | 4.5962 | 5200.0239 | 4.5962 | 5200.0247 | 4.7500 |



A D T

5. PHOTOGRAPHS OF THE TEST CONFIGURATION

Please refer to the attached file (Test Setup Photo).

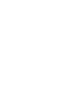



6. INFORMATION ON THE TESTING LABORATORIES

We, Bureau Veritas Consumer Products Services (H.K.) Ltd., Taoyuan Branch, were founded in 1988 to provide our best service in EMC, Radio, Telecom and Safety consultation. Our laboratories are accredited and approved according to ISO/IEC 17025.

If you have any comments, please feel free to contact us at the following:

Linko EMC/RF Lab:

Tel: 886-2-26052180

Fax: 886-2-26052943

Hsin Chu EMC/RF Lab:

Tel: 886-3-5935343

Fax: 886-3-5935342

Hwa Ya EMC/RF/Safety/Telecom Lab:

Tel: 886-3-3183232

Fax: 886-3-3270892

Email: service.adt@tw.bureauveritas.com

Web Site: www.bureauveritas-adt.com

The address and road map of all our labs can be found in our web site also.



A D T

7.APPENDIX A - MODIFICATIONS RECORDERS FOR ENGINEERING CHANGES TO THE EUT BY THE LAB

No modifications were made to the EUT by the lab during the test.

--- END ---