



FCC TEST REPORT (15.407)

REPORT NO.: RF130820E03-1

MODEL NO.: DIR-803

FCC ID: KA2IR803A1

RECEIVED: Aug. 22, 2013

TESTED: Aug. 22 to 23, 2013

ISSUED: Sep. 10, 2013

APPLICANT: D-Link Corporation

ADDRESS: 131 Theory Drive, Irvine, California, 92617
United States

ISSUED BY: Bureau Veritas Consumer Products Services
(H.K.) Ltd., Taoyuan Branch Hsin Chu Laboratory

LAB ADDRESS : No. 81-1, Lu Liao Keng, 9th Ling, Wu Lung Tsuen,
Chiung Lin Hsiang, Hsin Chu Hsien 307, Taiwan,
R.O.C.

TEST LOCATION (1): No. 81-1, Lu Liao Keng, 9th Ling, Wu Lung Tsuen,
Chiung Lin Hsiang, Hsin Chu Hsien 307, Taiwan,
R.O.C.

TEST LOCATION (2): No. 49, Ln. 206, Wende Rd., Shangshan Tsuen,
Chiung Lin Hsiang, Hsin Chu Hsien 307, Taiwan,
R.O.C.

This report should not be used by the client to claim product certification, approval, or endorsement by TAF or any government agencies.



This report is for your exclusive use. Any copying or replication of this report to or for any other person or entity, or use of our name or trademark, is permitted only with our prior written permission. This report sets forth our findings solely with respect to the test samples identified herein. The results set forth in this report are not indicative or representative of the quality or characteristics of the lot from which a test sample was taken or any similar or identical product unless specifically and expressly noted. Our report includes all of the tests requested by you and the results thereof based upon the information that you provided to us. You have 60 days from date of issuance of this report to notify us of any material error or omission caused by our negligence, provided, however, that such notice shall be in writing and shall specifically address the issue you wish to raise. A failure to raise such issue within the prescribed time shall constitute your unqualified acceptance of the completeness of this report, the tests conducted and the correctness of the report contents. Unless specific mention, the uncertainty of measurement has been explicitly taken into account to declare the compliance or non-compliance to the specification



A D T

Table of Contents

RELEASE CONTROL RECORD	4
1. CERTIFICATION.....	5
2. SUMMARY OF TEST RESULTS	6
2.1 MEASUREMENT UNCERTAINTY.....	7
3. GENERAL INFORMATION	8
3.1 GENERAL DESCRIPTION OF EUT	8
3.2 DESCRIPTION OF TEST MODES	11
3.2.1 TEST MODE APPLICABILITY AND TESTED CHANNEL DETAIL.....	12
3.3 GENERAL DESCRIPTION OF APPLIED STANDARDS	14
3.4 DUTY CYCLE OF TEST SIGNAL	15
3.5 DESCRIPTION OF SUPPORT UNITS	16
3.6 CONFIGURATION OF SYSTEM UNDER TEST.....	17
4. TEST TYPES AND RESULTS	18
4.1 CONDUCTED EMISSION MEASUREMENT.....	18
4.1.1 LIMITS OF CONDUCTED EMISSION MEASUREMENT	18
4.1.2 TEST INSTRUMENTS.....	18
4.1.3 TEST PROCEDURES	19
4.1.4 DEVIATION FROM TEST STANDARD.....	19
4.1.5 TEST SETUP.....	19
4.1.6 EUT OPERATING CONDITIONS	20
4.1.7 TEST RESULTS (MODE 1)	21
4.1.8 TEST RESULTS (MODE 2)	23
4.2 RADIATED EMISSION AND BANDEDGE MEASUREMENT	25
4.2.1 LIMITS OF RADIATED EMISSION AND BANDEDGE MEASUREMENT	25
4.2.2 LIMITS OF UNWANTED EMISSION OUT OF THE RESTRICTED BANDS.....	25
4.2.3 TEST INSTRUMENTS.....	26
4.2.4 TEST PROCEDURES	28
4.2.5 DEVIATION FROM TEST STANDARD.....	28
4.2.6 TEST SETUP.....	29
4.2.7 EUT OPERATING CONDITION.....	29
4.2.8 TEST RESULTS	30
4.3 TRANSMIT POWER MEASUREMENT	40
4.3.1 LIMITS OF TRANSMIT POWER MEASUREMENT	40
4.3.2 TEST INSTRUMENTS.....	40
4.3.3 TEST PROCEDURE.....	41
4.3.4 DEVIATION FROM TEST STANDARD.....	41
4.3.5 TEST SETUP.....	42
4.3.6 EUT OPERATING CONDITIONS	42
4.3.7 TEST RESULTS	43
4.4 PEAK POWER SPECTRAL DENSITY MEASUREMENT.....	47
4.4.1 LIMITS OF PEAK POWER SPECTRAL DENSITY MEASUREMENT	47
4.4.2 TEST INSTRUMENTS.....	47
4.4.3 TEST PROCEDURES	47



A D T

4.4.4	DEVIATION FROM TEST STANDARD	47
4.4.5	TEST SETUP	48
4.4.6	EUT OPERATING CONDITIONS	48
4.4.7	TEST RESULTS	49
4.5	PEAK POWER EXCURSION MEASUREMENT	50
4.5.1	LIMITS OF PEAK POWER EXCURSION MEASUREMENT	50
4.5.2	TEST INSTRUMENTS	50
4.5.3	TEST PROCEDURE	50
4.5.4	DEVIATION FROM TEST STANDARD	50
4.5.5	TEST SETUP	50
4.5.6	EUT OPERATING CONDITIONS	50
4.5.7	TEST RESULTS	51
4.6	FREQUENCY STABILITY	52
4.6.1	LIMITS OF FREQUENCY STABILITY MEASUREMENT	52
4.6.2	TEST INSTRUMENTS	52
4.6.3	TEST PROCEDURE	52
4.6.4	DEVIATION FROM TEST STANDARD	53
4.6.5	TEST SETUP	53
4.6.6	EUT OPERATING CONDITION	53
4.6.7	TEST RESULTS	54
5.	PHOTOGRAPHS OF THE TEST CONFIGURATION	55
6.	INFORMATION ON THE TESTING LABORATORIES	56
7.	APPENDIX A - MODIFICATIONS RECORDERS FOR ENGINEERING CHANGES TO THE EUT BY THE LAB.....	57



A D T

RELEASE CONTROL RECORD

ISSUE NO.	REASON FOR CHANGE	DATE ISSUED
RF130820E03-1	Original release	Sep. 10, 2013

2. SUMMARY OF TEST RESULTS

The EUT has been tested according to the following specifications:

For 5GHz, 5150~5250MHz

APPLIED STANDARD: FCC PART 15, SUBPART E (SECTION 15.407)			
STANDARD SECTION	TEST TYPE	RESULT	REMARK
15.407(b)(6)	AC Power Conducted Emission	PASS	Meet the requirement of limit. Minimum passing margin is -10.71dB at 8.45313MHz
15.407(b/1/2/3) (b)(6)	Spurious Emissions	PASS	Meet the requirement of limit. Minimum passing margin is -0.5dB at 5150.00MHz
15.407(a/1/2)	Transmit Power	PASS	Meet the requirement of limit.
15.407(a)(6)	Peak Power Excursion	PASS	Meet the requirement of limit.
15.407(a/1/2)	Peak Power Spectral Density	PASS	Meet the requirement of limit.
15.407(g)	Frequency Stability	PASS	Meet the requirement of limit.
15.203	Antenna Requirement	PASS	Antenna connector is I-pex not a standard connector.

NOTE: The EUT was operating in 2.400 ~ 2.4835GHz, 5.15~5.25GHz and 5.725~5.850GHz frequencies band. This report was recorded the RF parameters including 5.15~5.25GHz. For the 2.400 ~ 2.4835GHz and 5.725~5.850GHz RF parameters was recorded in another test report.

2.1 MEASUREMENT UNCERTAINTY

Where relevant, the following measurement uncertainty levels have been estimated for tests performed on the EUT as specified in CISPR 16-4-2:

This uncertainty represents an expanded uncertainty expressed at approximately the 95% confidence level using a coverage factor of $k=2$.

Measurement	Value
Conducted emissions	2.98 dB
Radiated emissions (30MHz-1GHz)	5.46 dB
Radiated emissions (1GHz -6GHz)	3.73 dB
Radiated emissions (6GHz -18GHz)	3.90 dB
Radiated emissions (18GHz -40GHz)	4.11 dB



A D T

3. GENERAL INFORMATION

3.1 GENERAL DESCRIPTION OF EUT

PRODUCT	Wireless AC750 Dual Band Router
MODEL NO.	DIR-803
POWER SUPPLY	DC 5V from power adapter
MODULATION TYPE	CCK, DQPSK, DBPSK for DSSS 64QAM, 16QAM, QPSK, BPSK for OFDM 256QAM for OFDM in 11ac mode only
MODULATION TECHNOLOGY	DSSS,OFDM
TRANSFER RATE	802.11b: up to 11Mbps 802.11a / g: up to 54Mbps 802.11n: up to 150Mbps 802.11ac: up to 433.3Mbps
OPERATING FREQUENCY	For 15.407 5GHz: 5.18 ~ 5.24GHz For 15.247 2.4GHz: 2.412 ~ 2.462GHz 5GHz: 5.745 ~ 5.825GHz
NUMBER OF CHANNEL	For 15.407 4 for 802.11a, 802.11n (HT20), 802.11ac (VHT20) 2 for 802.11n (HT40), 802.11ac (VHT40) 1 for 802.11ac (VHT80) For 15.247 (2.4GHz) 11 for 802.11b, 802.11g, 802.11n (HT20) 7 for 802.11n (HT40) For 15.407 (5GHz) 5 for 802.11a, 802.11n (HT20), 802.11ac (VHT20) 2 for 802.11n (HT40), 802.11ac (VHT40) 1 for 802.11ac (VHT80)

MAXIMUM OUTPUT POWER	For 15.407 802.11a: 41.400mW 802.11n (HT20): 41.591mW 802.11n (HT40): 48.753mW 802.11ac (VHT80): 25.704mW
	For 15.247 (2.4GHz) 802.11b: 159.485mW 802.11g: 967.785mW 802.11n (HT20): 892.387mW 802.11n (HT40): 579.109mW
	For 15.247 (5GHz) 802.11a: 221.820mW 802.11n (HT20): 224.905mW 802.11n (HT40): 214.289mW 802.11ac (VHT80): 472.063mW
ANTENNA TYPE	Please see NOTE
DATA CABLE	NA
I/O PORTS	Refer to user's manual
ASSOCIATED DEVICES	Adapter x1

NOTE:

1. The EUT is a 2.4GHz & 5GHz WLAN device.
2. The antennas provided to the EUT, please refer to the following table:

Set 1							
Ant.	Transmitter Circuit	Model	Gain (dBi) (Include cable loss)	Antenna Type	Connector Type	Frequency range (MHz to MHz)	Cable Length (mm)
A	Chain (0)	290-20045	2.64	Dipole	NA	2400~2500	170
	Chain (0)		2.67	Dipole	I-pex	5150~5250	60
			3.67			5725~5850	
B	Chain (1)	G070-310068-A	3.93	Dipole	NA	2400~2500	65
Set 2							
Ant.	Transmitter Circuit	Model	Gain (dBi) (Include cable loss)	Antenna Type	Connector Type	Frequency range (MHz to MHz)	Cable Length (mm)
A	Chain (0)	290-20045	2.64	Dipole	NA	2400~2500	170
	Chain (0)		2.67	Dipole	I-pex	5150~5250	60
			3.67			5725~5850	
B	Chain (1)	290-20071	3.0	Dipole	NA	2400~2500	65

From the above antennas, antenna set 1 was selected for the test and its data was recorded in this report.

3. The EUT must be supplied with a power adapter as following table:

No	Brand	Model No.	Spec.
1	D-Link	AMS47-0501000FU	Input: 100-240V, 0.2A, 50/60Hz Output: 5V, 1A DC output cable (Unshielded, 1.5m)
2	D-Link	F05W-050100SPAU	Input: 100-240V, 190mA, 50/60Hz Output: 5V, 1A DC output cable (Unshielded, 1.5m)

For radiated emissions test, the worst case was found in Adapter 2. Therefore only the test data of the Adapter 2 was recorded in this report.

4. The EUT incorporates a MIMO function without beam forming.

MODULATION MODE	TX/RX FUNCTION
802.11b	2TX/2RX
802.11g	2TX/2RX
802.11n (HT20) <2.4GHz>	2TX/2RX
802.11n (HT40) <2.4GHz>	2TX/2RX
802.11a	1TX/1RX
802.11n (HT20) <5GHz>	1TX/1RX
802.11n (HT40) <5GHz>	1TX/1RX
802.11ac (VHT20)	1TX/1RX
802.11ac (VHT40)	1TX/1RX
802.11ac (VHT80)	1TX/1RX

Note: The modulation and bandwidth are similar for 802.11n mode for 20MHz (40MHz) and 802.11ac mode for 20MHz (40MHz), therefore investigated worst case to representative mode in test report. (Final test mode refer section 3.2.1)

5. The emission of the simultaneous operation (2.4GHz & 5GHz) has been evaluated and no non-compliance was found.
6. When the EUT operating in 802.11n, the software operation, which is defined by manufacturer, for 2.4GHz: MCS (Modulation and Coding Schemes) from 0 to 15; for 5GHz: MCS (Modulation and Coding Schemes) from 0 to 7.
7. When the EUT operating in 802.11ac, the software operation, which is defined by manufacturer, MCS (Modulation and Coding Schemes) from 0 to 9.
8. The above EUT information was declared by the manufacturer and for more detailed features description, please refer to the manufacturer's specifications or User's Manual.

3.2 DESCRIPTION OF TEST MODES

Operated in 5150 ~ 5250MHz band:

4 channels are provided for 802.11a, 802.11n (HT20), 802.11ac (VHT20):

CHANNEL	FREQUENCY	CHANNEL	FREQUENCY
36	5180 MHz	44	5220 MHz
40	5200 MHz	48	5240 MHz

2 channels are provided for 802.11n (HT40), 802.11ac (VHT40):

CHANNEL	FREQUENCY
38	5190 MHz
46	5230 MHz

1 channel is provided for 802.11ac (VHT80):

CHANNEL	FREQUENCY
42	5210 MHz

3.2.1 TEST MODE APPLICABILITY AND TESTED CHANNEL DETAIL

EUT CONFIGURE MODE	APPLICABLE TO				DESCRIPTION
	PLC	RE < 1G	RE ≥ 1G	APCM	
1	√	-	-	-	Adapter 1
2	√	√	√	√	Adapter 2

Where **PLC**: Power Line Conducted Emission **RE < 1G**: Radiated Emission below 1GHz
RE ≥ 1G: Radiated Emission above 1GHz **APCM**: Antenna Port Conducted Measurement

POWER LINE CONDUCTED EMISSION TEST:

- Pre-Scan has been conducted to determine the worst-case mode from all possible combinations between available modulations, data rates and antenna ports (if EUT with antenna diversity architecture).
- Following channel(s) was (were) selected for the final test as listed below.

MODE	AVAILABLE CHANNEL	TESTED CHANNEL	MODULATION TECHNOLOGY	MODULATION TYPE	DATA RATE (MBPS)
802.11n (HT40)	38 to 46	38	OFDM	BPSK	13.5

RADIATED EMISSION TEST (BELOW 1 GHz):

- Pre-Scan has been conducted to determine the worst-case mode from all possible combinations between available modulations, data rates and antenna ports (if EUT with antenna diversity architecture).
- Following channel(s) was (were) selected for the final test as listed below.

MODE	AVAILABLE CHANNEL	TESTED CHANNEL	MODULATION TECHNOLOGY	MODULATION TYPE	DATA RATE (Mbps)
802.11n (HT40)	38 to 46	38	OFDM	BPSK	13.5



RADIATED EMISSION TEST (ABOVE 1 GHz):

- Pre-Scan has been conducted to determine the worst-case mode from all possible combinations between available modulations, data rates and antenna ports (if EUT with antenna diversity architecture).
- Following channel(s) was (were) selected for the final test as listed below.

MODE	AVAILABLE CHANNEL	TESTED CHANNEL	MODULATION TECHNOLOGY	MODULATION TYPE	DATA RATE (Mbps)
802.11a	36 to 48	36, 40, 48	OFDM	BPSK	6
802.11n (HT20)	36 to 48	36, 40, 48	OFDM	BPSK	6.5
802.11n (HT40)	38 to 46	38, 46	OFDM	BPSK	13.5
802.11ac (VHT80)	42	42	OFDM	BPSK	29.3

ANTENNA PORT CONDUCTED MEASUREMENT:

- Pre-Scan has been conducted to determine the worst-case mode from all possible combinations between available modulations, data rates and antenna ports (if EUT with antenna diversity architecture).
- Following channel(s) was (were) selected for the final test as listed below.

MODE	AVAILABLE CHANNEL	TESTED CHANNEL	MODULATION TECHNOLOGY	MODULATION TYPE	DATA RATE (Mbps)
802.11a	36 to 48	36, 40, 48	OFDM	BPSK	6
802.11n (HT20)	36 to 48	36, 40, 48	OFDM	BPSK	6.5
802.11n (HT40)	38 to 46	38, 46	OFDM	BPSK	13.5
802.11ac (VHT80)	42	42	OFDM	BPSK	29.3

TEST CONDITION:

APPLICABLE TO	ENVIRONMENTAL CONDITIONS	INPUT POWER	TESTED BY
PLC	25deg. C, 65%RH	120Vac, 60Hz	Barry Lee
RE<1G	25deg. C, 68%RH	120Vac, 60Hz	Tim Ho
RE≥1G	23deg. C, 67%RH	120Vac, 60Hz	Tim Ho
APCM	25deg. C, 60%RH	120Vac, 60Hz	James Chan

3.3 GENERAL DESCRIPTION OF APPLIED STANDARDS

The EUT is a RF product. According to the specifications of the manufacturer, it must comply with the requirements of the following standards:

FCC Part 15, Subpart E (15.407)

789033 D01 General UNII Test Procedures v01 r03

ANSI C63.10-2009

All test items have been performed and recorded as per the above standards.

Note: The EUT has been verified to comply with the requirements of FCC Part 15, Subpart B, Class B (DoC). The test report has been issued separately.

3.4 DUTY CYCLE OF TEST SIGNAL

Duty cycle of test signal is 100 %, duty factor is not required.

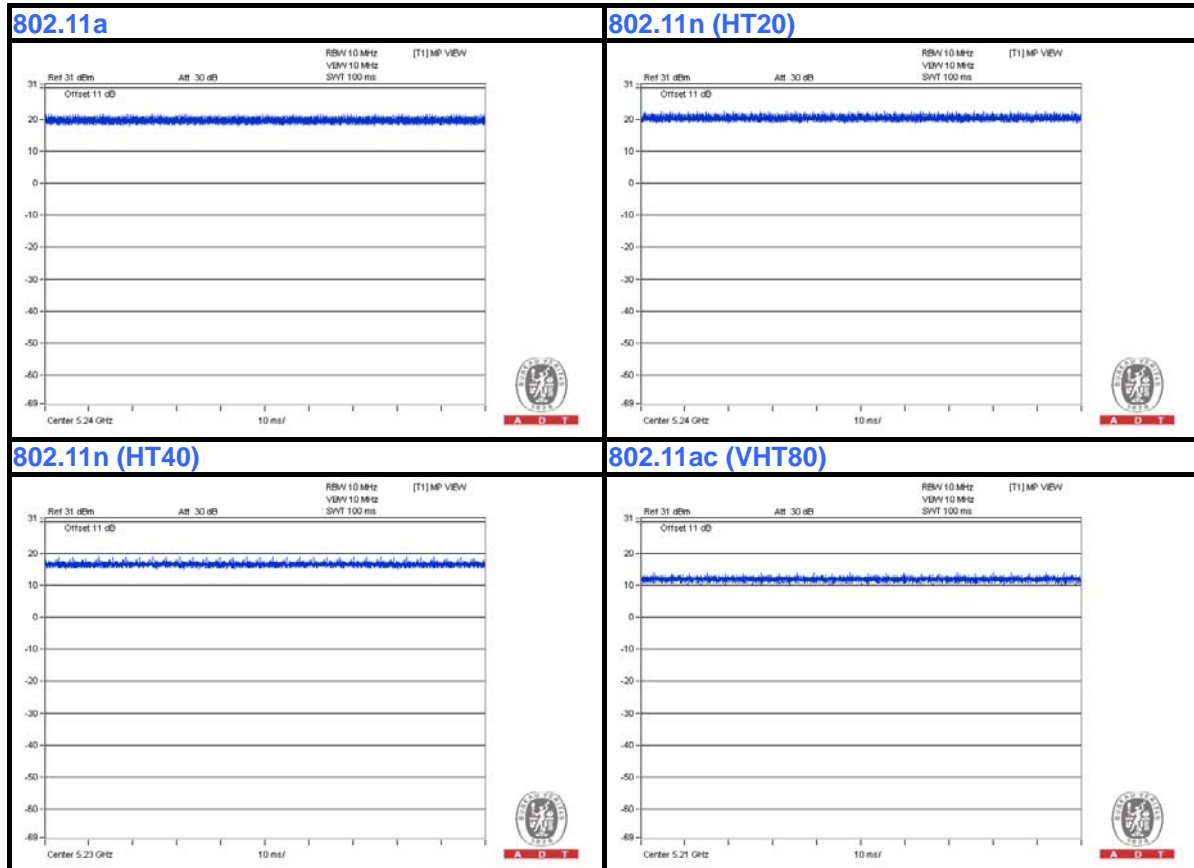



A D T

3.5 DESCRIPTION OF SUPPORT UNITS

The EUT has been tested as an independent unit together with other necessary accessories or support units. The following support units or accessories were used to form a representative test configuration during the tests.

NO.	PRODUCT	BRAND	MODEL NO.	SERIAL NO.	FCC ID
1	NOTEBOOK COMPUTER	DELL	PP32LA	GSLB32S	FCC DoC
2	HUB	ZyXEL	ES-116P	S060H02000215	FCC DoC

NO.	SIGNAL CABLE DESCRIPTION OF THE ABOVE SUPPORT UNITS
1	UTP cable, 10m
2	UTP cable, 10m

NOTE: All power cords of the above support units are non shielded (1.8m).

3.6 CONFIGURATION OF SYSTEM UNDER TEST

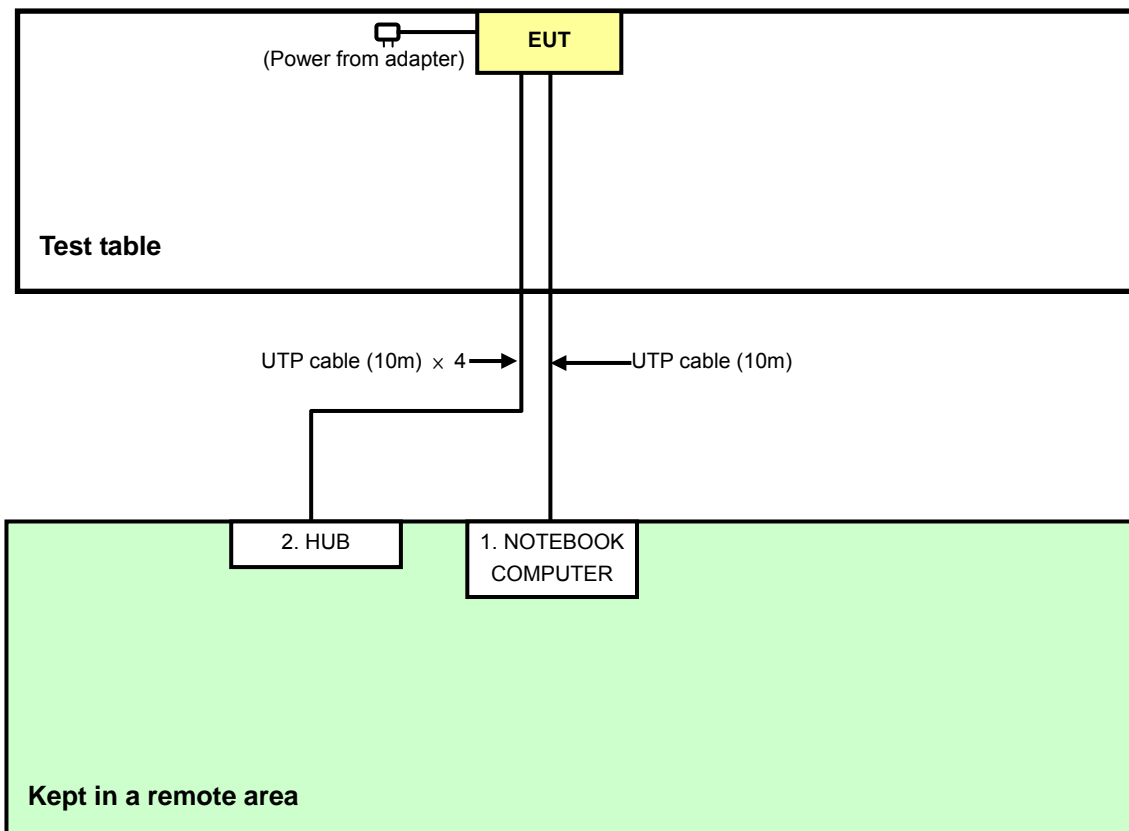

4. TEST TYPES AND RESULTS

4.1 CONDUCTED EMISSION MEASUREMENT

4.1.1 LIMITS OF CONDUCTED EMISSION MEASUREMENT

FREQUENCY OF EMISSION (MHz)	CONDUCTED LIMIT (dB μ V)	
	Quasi-peak	Average
0.15-0.5	66 to 56	56 to 46
0.5-5	56	46
5-30	60	50

- NOTE:**
1. The lower limit shall apply at the transition frequencies.
 2. The limit decreases in line with the logarithm of the frequency in the range of 0.15 to 0.50 MHz.

4.1.2 TEST INSTRUMENTS

DESCRIPTION & MANUFACTURER	MODEL NO.	SERIAL NO.	CALIBRATED DATE	CALIBRATED UNTIL
Test Receiver ROHDE & SCHWARZ	ESCS 30	100375	Mar. 08, 2013	Mar. 07, 2014
Line-Impedance Stabilization Network (for EUT) SCHWARZBECK	NSLK8127	8127-522	Sep. 06, 2012	Sep. 05, 2013
Line-Impedance Stabilization Network (for Peripheral)	ENV216	100072	June 07, 2013	June 06, 2014
RF Cable (JYEBAO)	5DFB	COCCAB-001	Mar. 11, 2013	Mar. 10, 2014
50 ohms Terminator	50	EMC-3	Sep. 25, 2012	Sep. 24, 2013
Software ADT	BV ADT_Cond_V7.3.7. 3	NA	NA	NA

Note:

1. The calibration interval of the above test instruments is 12 months and the calibrations are traceable to NML/ROC and NIST/USA.
2. The test was performed in Shielded Room No. C.
3. The VCCI Con C Registration No. is C-3611.
4. Tested Date: Aug. 22, 2013

4.1.3 TEST PROCEDURES

- a. The EUT was placed 0.4 meters from the conducting wall of the shielded room with EUT being connected to the power mains through a line impedance stabilization network (LISN). Other support units were connected to the power mains through another LISN.
- b. The two LISNs provide 50 ohm/ 50uH of coupling impedance for the measuring instrument.
- c. Both lines of the power mains connected to the EUT were checked for maximum conducted interference.
- d. The frequency range from 150kHz to 30MHz was searched. Emission level under (Limit – 20dB) was not recorded.

NOTE:

1. The resolution bandwidth of test receiver is 9kHz for Quasi-peak detection (QP) & Average detection (AV).

4.1.4 DEVIATION FROM TEST STANDARD

No deviation

4.1.5 TEST SETUP

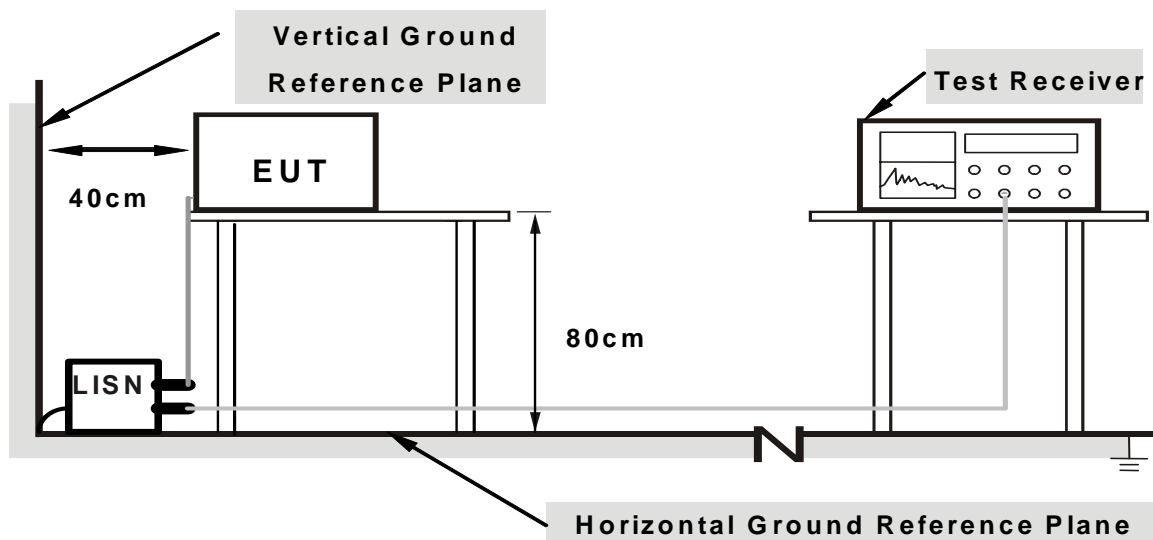

Note: 1.Support units were connected to second LISN.

For the actual test configuration, please refer to the related item – Photographs of the Test Configuration.

4.1.6 EUT OPERATING CONDITIONS

1. Turn on the power of EUT.
2. The communication partner run test program “RTL819x2.3” to enable EUT under transmission/receiving condition continuously at specific channel frequency.

4.1.7 TEST RESULTS (MODE 1)

PHASE	Line (L)	DETECTOR FUNCTION	Quasi-Peak (QP) / Average (AV)
--------------	----------	--------------------------	--------------------------------

No	Freq. [MHz]	Corr. Factor (dB)	Reading Value [dB (uV)]		Emission Level [dB (uV)]		Limit [dB (uV)]		Margin (dB)	
			Q.P.	AV.	Q.P.	AV.	Q.P.	AV.	Q.P.	AV.
1	0.43906	0.20	42.84	33.84	43.04	34.04	57.08	47.08	-14.04	-13.04
2	0.69297	0.22	41.07	33.90	41.29	34.12	56.00	46.00	-14.71	-11.88
3	0.84531	0.24	39.53	31.09	39.77	31.33	56.00	46.00	-16.23	-14.67
4	2.25000	0.36	42.81	34.58	43.17	34.94	56.00	46.00	-12.83	-11.06
5	3.58984	0.44	39.74	30.88	40.18	31.32	56.00	46.00	-15.82	-14.68
6	8.45313	0.79	47.52	38.50	48.31	39.29	60.00	50.00	-11.69	-10.71

REMARKS:

1. Q.P. and AV. are abbreviations of quasi-peak and average individually.
2. The emission levels of other frequencies were very low against the limit.
3. Margin value = Emission Level – Limit value
4. Correction Factor = Insertion loss + Cable loss
5. Emission Level = Correction Factor + Reading Value

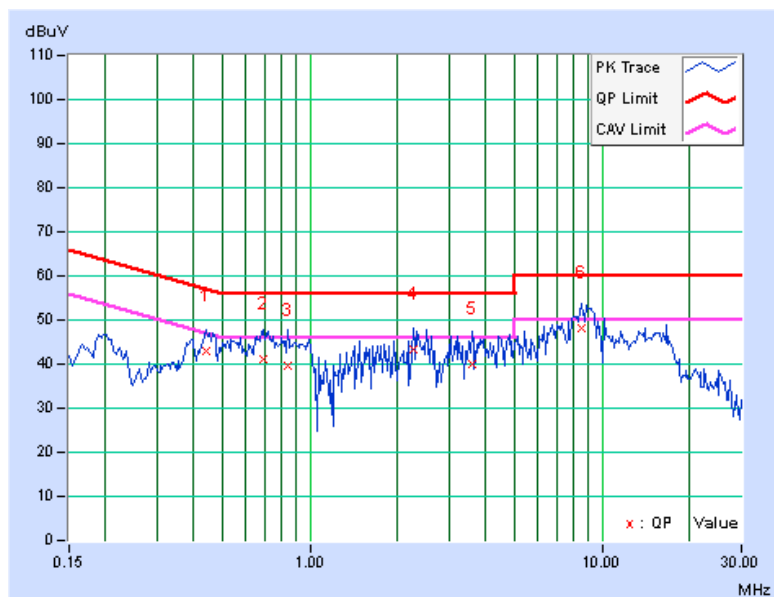

PHASE	Neutral (N)	DETECTOR FUNCTION	Quasi-Peak (QP) / Average (AV)
--------------	-------------	--------------------------	--------------------------------

No	Freq.	Corr.	Reading Value		Emission Level		Limit		Margin	
	[MHz]	Factor	[dB (uV)]		[dB (uV)]		[dB (uV)]		(dB)	
		(dB)	Q.P.	AV.	Q.P.	AV.	Q.P.	AV.	Q.P.	AV.
1	0.44297	0.19	41.24	30.25	41.43	30.44	57.01	47.01	-15.57	-16.56
2	0.69688	0.20	39.78	29.27	39.98	29.47	56.00	46.00	-16.02	-16.53
3	1.61328	0.27	39.13	29.63	39.40	29.90	56.00	46.00	-16.60	-16.10
4	7.86328	0.63	42.49	32.83	43.12	33.46	60.00	50.00	-16.88	-16.54
5	8.91406	0.68	45.96	36.14	46.64	36.82	60.00	50.00	-13.36	-13.18
6	15.04688	0.96	42.09	31.57	43.05	32.53	60.00	50.00	-16.95	-17.47

REMARKS:

1. Q.P. and AV. are abbreviations of quasi-peak and average individually.
2. The emission levels of other frequencies were very low against the limit.
3. Margin value = Emission Level – Limit value
4. Correction Factor = Insertion loss + Cable loss
5. Emission Level = Correction Factor + Reading Value

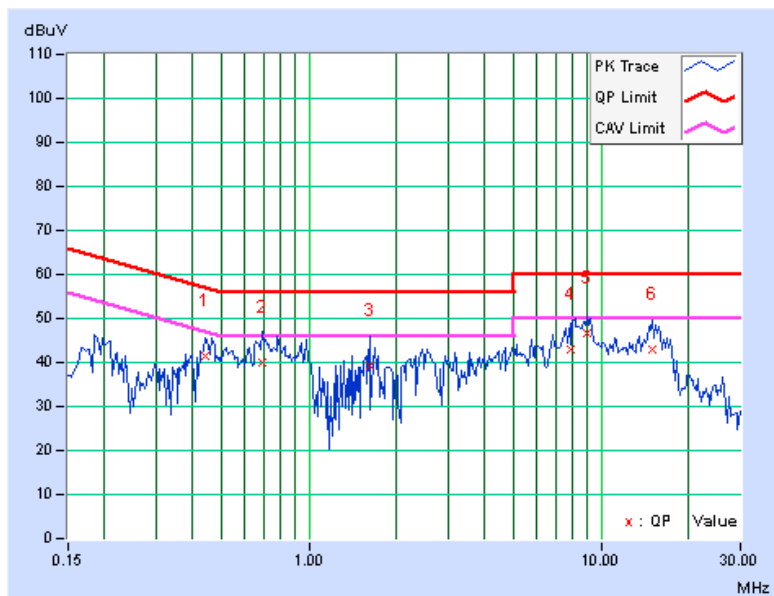

4.1.8 TEST RESULTS (MODE 2)

PHASE	Line (L)	DETECTOR FUNCTION	Quasi-Peak (QP) / Average (AV)
--------------	----------	--------------------------	--------------------------------

No	Freq. [MHz]	Corr. Factor [dB]	Reading Value [dB (uV)]		Emission Level [dB (uV)]		Limit [dB (uV)]		Margin (dB)	
			Q.P.	AV.	Q.P.	AV.	Q.P.	AV.	Q.P.	AV.
1	0.17734	0.14	44.35	21.56	44.49	21.70	64.61	54.61	-20.12	-32.91
2	0.21641	0.15	44.70	34.32	44.85	34.47	62.96	52.96	-18.10	-18.48
3	0.50156	0.21	43.78	33.65	43.99	33.86	56.00	46.00	-12.01	-12.14
4	0.74375	0.23	36.06	27.96	36.29	28.19	56.00	46.00	-19.71	-17.81
5	16.16797	1.26	39.28	33.74	40.54	35.00	60.00	50.00	-19.46	-15.00
6	23.12891	1.56	40.10	34.21	41.66	35.77	60.00	50.00	-18.34	-14.23

REMARKS:

1. Q.P. and AV. are abbreviations of quasi-peak and average individually.
2. The emission levels of other frequencies were very low against the limit.
3. Margin value = Emission Level – Limit value
4. Correction Factor = Insertion loss + Cable loss
5. Emission Level = Correction Factor + Reading Value

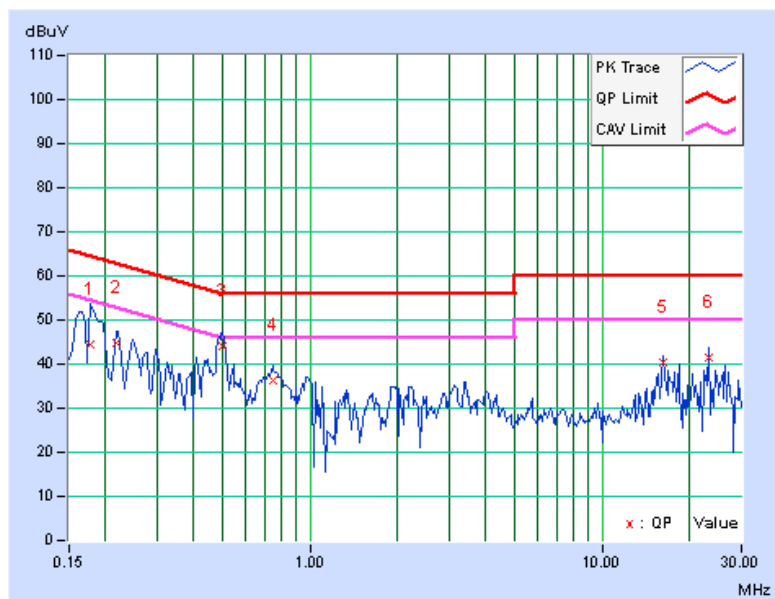

PHASE	Neutral (N)	DETECTOR FUNCTION	Quasi-Peak (QP) / Average (AV)
--------------	-------------	--------------------------	--------------------------------

No	Freq.	Corr.	Reading Value		Emission Level		Limit		Margin	
	[MHz]	Factor	[dB (uV)]		[dB (uV)]		[dB (uV)]		(dB)	
		(dB)	Q.P.	AV.	Q.P.	AV.	Q.P.	AV.	Q.P.	AV.
1	0.15391	0.11	41.44	22.70	41.55	22.81	65.79	55.79	-24.23	-32.97
2	0.19297	0.13	48.59	38.32	48.72	38.45	63.91	53.91	-15.19	-15.46
3	0.23203	0.14	37.91	17.68	38.05	17.82	62.38	52.38	-24.33	-34.56
4	0.45859	0.19	31.76	21.29	31.95	21.48	56.72	46.72	-24.77	-25.24
5	0.98984	0.22	27.16	19.71	27.38	19.93	56.00	46.00	-28.62	-26.07
6	18.24219	1.06	34.54	28.94	35.60	30.00	60.00	50.00	-24.40	-20.00

REMARKS:

1. Q.P. and AV. are abbreviations of quasi-peak and average individually.
2. The emission levels of other frequencies were very low against the limit.
3. Margin value = Emission Level – Limit value
4. Correction Factor = Insertion loss + Cable loss
5. Emission Level = Correction Factor + Reading Value

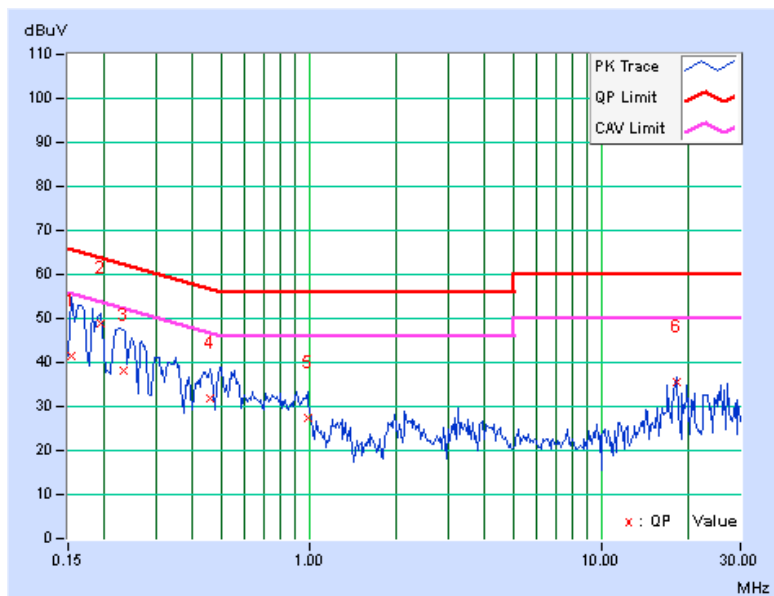

4.2 RADIATED EMISSION AND BANDEGE MEASUREMENT

4.2.1 LIMITS OF RADIATED EMISSION AND BANDEGE MEASUREMENT

Radiated emissions which fall in the restricted bands must comply with the radiated emission limits specified as below table:

Frequencies (MHz)	Field strength (microvolts/meter)	Measurement distance (meters)
0.009-0.490	2400/F(kHz)	300
0.490-1.705	24000/F(kHz)	30
1.705-30.0	30	30
30-88	100	3
88-216	150	3
216-960	200	3
Above 960	500	3

NOTE:

1. The lower limit shall apply at the transition frequencies.
2. Emission level (dBuV/m) = 20 log Emission level (uV/m).
3. For frequencies above 1000MHz, the field strength limits are based on average detector, however, the peak field strength of any emission shall not exceed the maximum permitted average limits, specified above by more than 20dB.

4.2.2 LIMITS OF UNWANTED EMISSION OUT OF THE RESTRICTED BANDS

APPLICABLE TO	LIMIT	
√	FIELD STRENGTH AT 3m (dBμV/m)	
	PK	AV
	74	54
-	EIRP LIMIT (dBm)	EQUIVALENT FIELD STRENGTH AT 3m (dBμV/m)
	PK	PK
	-27	68.3

NOTE:

1. The following formula is used to convert the equipment isotropic radiated power (eirp) to field strength:

$$E = \frac{1000000\sqrt{30P}}{3} \mu\text{V/m, where P is the eirp (Watts).}$$



A D T

4.2.3 TEST INSTRUMENTS

For below 1GHz test:

DESCRIPTION & MANUFACTURER	MODEL NO.	SERIAL NO.	CALIBRATED DATE	CALIBRATED UNTIL
Spectrum Analyzer Agilent	E4446A	MY48250253	Sep. 03, 2012	Sep. 02, 2013
MXE EMI Receiver Agilent	N9038A	MY50010156	Jan. 16, 2013	Jan. 15, 2014
Pre-Amplifier Mini-Circuits	ZFL-1000VH2 B	AMP-ZFL-04	Nov. 14, 2012	Nov. 13, 2013
Pre-Amplifier Agilent	8449B	3008A01923	Oct. 30, 2012	Oct. 29, 2013
Pre-Amplifier SPACEK LABS	SLKKa-48-6	9K16	Nov. 14, 2012	Nov. 13, 2013
Trilog Broadband Antenna SCHWARZBECK	VULB 9168	9168-361	Mar. 25, 2013	Mar. 24, 2014
Horn_Antenna AISI	AIH.8018	0000220091110	Nov. 27, 2012	Nov. 26, 2013
Horn_Antenna SCHWARZBECK	BBHA 9170	9170-424	Oct. 12, 2012	Oct. 11, 2013
RF Cable	NA	RF104-205 RF104-207 RF104-202	Dec. 26, 2012	Dec. 25, 2013
RF Cable	NA	CHHCAB_001	Oct. 07, 2012	Oct. 06, 2013
Software	ADT_Radiated _V8.7.05	NA	NA	NA
Antenna Tower & Turn Table CT	NA	NA	NA	NA

Note:

1. The calibration interval of the above test instruments is 12 months and the calibrations are traceable to NML/ROC and NIST/USA.
2. The horn antenna, preamplifier (model: 8449B) are used only for the measurement of emission frequency above 1GHz if tested.
3. The test was performed in 966 Chamber No. H.
4. The FCC Site Registration No. is 797305.
5. The CANADA Site Registration No. is IC 7450H-3.
6. Tested Date: Aug. 23, 2013



A D T

For above 1GHz test:

DESCRIPTION & MANUFACTURER	MODEL NO.	SERIAL NO.	CALIBRATED DATE	CALIBRATED UNTIL
Spectrum Analyzer Agilent	E4446A	MY48250253	Sep. 03, 2012	Sep. 02, 2013
MXE EMI Receiver Agilent	N9038A	MY51210105	Jan. 29,2013	Jan. 28,2014
Pre-Amplifier Mini-Circuits	ZFL-1000VH2 B	AMP-ZFL-03	Nov. 14, 2012	Nov. 13, 2013
Pre-Amplifier Agilent	8449B	3008A02578	June 25, 2013	June 24, 2014
Pre-Amplifier SPACEK LABS	SLKKa-48-6	9K16	Nov. 14, 2012	Nov. 13, 2013
Trilog Broadband Antenna SCHWARZBECK	VULB 9168	9168-360	Mar. 19, 2013	Mar. 18, 2014
Horn_Antenna AISl	AIH.8018	0000320091110	Nov. 19, 2012	Nov. 18, 2013
Horn_Antenna SCHWARZBECK	BBHA 9170	9170-424	Oct. 12, 2012	Oct. 11, 2013
RF Cable	NA	RF104-201 RF104-203 RF104-204	Dec. 25, 2012	Dec. 24, 2013
RF Cable	NA	CHGCAB_001	Oct. 06, 2012	Oct. 05, 2013
Software	ADT_Radiated _V8.7.05	NA	NA	NA
Antenna Tower & Turn Table CT	NA	NA	NA	NA

Note:

1. The calibration interval of the above test instruments is 12 months and the calibrations are traceable to NML/ROC and NIST/USA.
2. The horn antenna, preamplifier (model: 8449B) are used only for the measurement of emission frequency above 1GHz if tested.
3. The test was performed in 966 Chamber No. G.
4. The FCC Site Registration No. is 966073.
5. The VCCI Site Registration No. is G-137.
6. The CANADA Site Registration No. is IC 7450H-2.
7. Tested Date: Aug. 23, 2013

4.2.4 TEST PROCEDURES

- a. The EUT was placed on the top of a rotating table 0.8 meters above the ground at 3 meter chamber room for test. The table was rotated 360 degrees to determine the position of the highest radiation.
- b. The EUT was set 3 meters away from the interference-receiving antenna, which was mounted on the top of a variable-height antenna tower.
- c. The height of antenna is varied from one meter to four meters above the ground to determine the maximum value of the field strength. Both horizontal and vertical polarizations of the antenna are set to make the measurement.
- d. For each suspected emission, the EUT was arranged to its worst case and then the antenna was tuned to heights from 1 meter to 4 meters and the rotatable table was turned from 0 degrees to 360 degrees to find the maximum reading.
- e. The test-receiver system was set to quasi-peak detect function and specified bandwidth with maximum hold mode when the test frequency is below 1 GHz.
- f. The test-receiver system was set to peak and average detect function and specified bandwidth with maximum hold mode when the test frequency is above 1 GHz. If the peak reading value also meets average limit, measurement with the average detector is unnecessary.

NOTE:

1. The resolution bandwidth and video bandwidth of test receiver/spectrum analyzer is 120kHz for Quasi-peak detection (QP) at frequency below 1GHz.
2. The resolution bandwidth of test receiver/spectrum analyzer is 1 MHz and the video bandwidth is 3 MHz for Peak detection (PK) at frequency above 1GHz.
3. The resolution bandwidth of test receiver/spectrum analyzer is 1 MHz and the video bandwidth is 10 Hz for Average detection (AV) at frequency above 1GHz.
4. All modes of operation were investigated and the worst-case emissions are reported.

4.2.5 DEVIATION FROM TEST STANDARD

No deviation

4.2.6 TEST SETUP

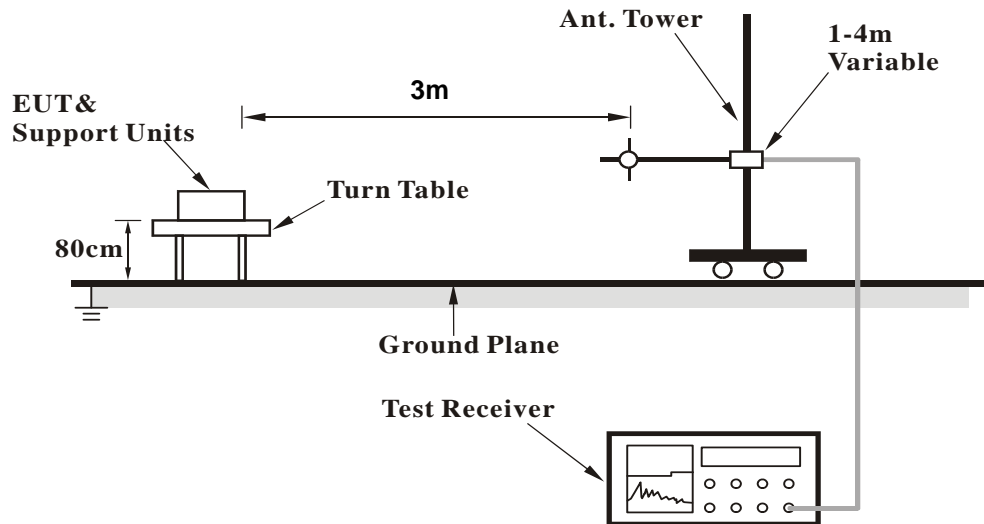

For the actual test configuration, please refer to the related item – Photographs of the Test Configuration.

4.2.7 EUT OPERATING CONDITION

Same as 4.1.6

4.2.8 TEST RESULTS

BELOW 1GHz WORST-CASE DATA

802.11n (HT40)

CHANNEL	TX Channel 38	DETECTOR FUNCTION	Quasi-Peak (QP)
FREQUENCY RANGE	Below 1GHz		

ANTENNA POLARITY & TEST DISTANCE: HORIZONTAL AT 3 M								
NO.	FREQ. (MHz)	EMISSION LEVEL (dBuV/m)	LIMIT (dBuV/m)	MARGIN (dB)	ANTENNA HEIGHT (m)	TABLE ANGLE (Degree)	RAW VALUE (dBuV)	CORRECTION FACTOR (dB/m)
1	149.97	26.8 QP	43.5	-16.7	1.50 H	112	40.05	-13.29
2	200.99	26.1 QP	43.5	-17.4	2.00 H	236	42.54	-16.45
3	319.03	30.2 QP	46.0	-15.8	1.50 H	259	41.66	-11.48
4	337.75	32.9 QP	46.0	-13.1	2.00 H	169	43.96	-11.07
5	498.91	26.0 QP	46.0	-20.0	1.50 H	269	33.56	-7.59
6	968.51	39.0 QP	54.0	-15.0	1.50 H	295	37.76	1.23
ANTENNA POLARITY & TEST DISTANCE: VERTICAL AT 3 M								
NO.	FREQ. (MHz)	EMISSION LEVEL (dBuV/m)	LIMIT (dBuV/m)	MARGIN (dB)	ANTENNA HEIGHT (m)	TABLE ANGLE (Degree)	RAW VALUE (dBuV)	CORRECTION FACTOR (dB/m)
1	30.24	33.3 QP	40.0	-6.7	1.00 V	187	47.54	-14.27
2	51.96	36.7 QP	40.0	-3.3	2.00 V	173	49.82	-13.08
3	193.99	28.9 QP	43.5	-14.6	1.00 V	287	45.20	-16.26
4	256.97	26.5 QP	46.0	-19.5	1.00 V	232	40.50	-13.99
5	579.87	28.9 QP	46.0	-17.1	2.00 V	131	34.78	-5.89
6	966.92	34.0 QP	54.0	-20.0	1.00 V	198	32.84	1.15

REMARKS:

1. Emission Level(dBuV/m) = Raw Value(dBuV) + Correction Factor(dB/m)
2. Correction Factor(dB/m) = Antenna Factor(dB/m) + Cable Factor(dB)
– Pre-Amplifier Factor(dB)
3. The other emission levels were very low against the limit.
4. Margin value = Emission Level – Limit value

ABOVE 1GHz DATA

802.11a

CHANNEL	TX Channel 36	DETECTOR FUNCTION	Peak (PK)
FREQUENCY RANGE	1GHz ~ 40GHz		Average (AV)

ANTENNA POLARITY & TEST DISTANCE: HORIZONTAL AT 3 M

NO.	FREQ. (MHz)	EMISSION LEVEL (dBuV/m)	LIMIT (dBuV/m)	MARGIN (dB)	ANTENNA HEIGHT (m)	TABLE ANGLE (Degree)	RAW VALUE (dBuV)	CORRECTION FACTOR (dB/m)
1	5105.00	54.5 PK	74.0	-19.5	1.09 H	23	46.16	8.34
2	5105.00	42.5 AV	54.0	-11.5	1.09 H	23	34.16	8.34
3	5150.00	63.6 PK	74.0	-10.4	1.09 H	23	55.00	8.60
4	5150.00	47.2 AV	54.0	-6.8	1.09 H	23	38.60	8.60
5	*5180.00	101.7 PK			1.09 H	23	92.94	8.76
6	*5180.00	93.0 AV			1.09 H	23	84.24	8.76
7	#10360.00	54.7 PK	74.0	-19.3	1.18 H	36	39.16	15.54
8	#10360.00	42.8 AV	54.0	-11.2	1.18 H	36	27.26	15.54
9	15540.00	54.7 PK	74.0	-19.3	1.00 H	273	32.33	22.37
10	15540.00	42.1 AV	54.0	-11.9	1.00 H	273	19.73	22.37

ANTENNA POLARITY & TEST DISTANCE: VERTICAL AT 3 M

NO.	FREQ. (MHz)	EMISSION LEVEL (dBuV/m)	LIMIT (dBuV/m)	MARGIN (dB)	ANTENNA HEIGHT (m)	TABLE ANGLE (Degree)	RAW VALUE (dBuV)	CORRECTION FACTOR (dB/m)
1	5105.00	60.0 PK	74.0	-14.0	1.02 V	30	51.66	8.34
2	5105.00	48.0 AV	54.0	-6.0	1.02 V	30	39.66	8.34
3	5150.00	69.4 PK	74.0	-4.6	1.00 V	327	60.80	8.60
4	5150.00	53.3 AV	54.0	-0.7	1.00 V	327	44.70	8.60
5	*5180.00	111.3 PK			1.00 V	327	102.54	8.76
6	*5180.00	102.6 AV			1.00 V	327	93.84	8.76
7	#10360.00	59.3 PK	74.0	-14.7	1.06 V	360	43.76	15.54
8	#10360.00	45.9 AV	54.0	-8.1	1.06 V	360	30.36	15.54
9	15540.00	60.0 PK	74.0	-14.0	1.15 V	96	37.63	22.37
10	15540.00	47.2 AV	54.0	-6.8	1.15 V	96	24.83	22.37

REMARKS:

- Emission Level(dBuV/m) = Raw Value(dBuV) + Correction Factor(dB/m)
- Correction Factor(dB/m) = Antenna Factor(dB/m) + Cable Factor(dB)
– Pre-Amplifier Factor(dB)
- The other emission levels were very low against the limit.
- Margin value = Emission Level – Limit value
- " * ": Fundamental frequency.
- " # ": The radiated frequency is out of the restricted band.

CHANNEL	TX Channel 40	DETECTOR FUNCTION	Peak (PK)
FREQUENCY RANGE	1GHz ~ 40GHz		Average (AV)

ANTENNA POLARITY & TEST DISTANCE: HORIZONTAL AT 3 M

NO.	FREQ. (MHz)	EMISSION LEVEL (dBuV/m)	LIMIT (dBuV/m)	MARGIN (dB)	ANTENNA HEIGHT (m)	TABLE ANGLE (Degree)	RAW VALUE (dBuV)	CORRECTION FACTOR (dB/m)
1	5150.00	58.4 PK	74.0	-15.6	1.03 H	36	49.80	8.60
2	5150.00	42.8 AV	54.0	-11.2	1.03 H	36	34.20	8.60
3	*5200.00	104.1 PK			1.03 H	36	95.23	8.87
4	*5200.00	94.6 AV			1.03 H	36	85.73	8.87
5	#10400.00	54.1 PK	74.0	-19.9	1.18 H	12	38.92	15.18
6	#10400.00	42.6 AV	54.0	-11.4	1.18 H	12	27.42	15.18
7	15600.00	55.1 PK	74.0	-18.9	1.04 H	261	32.98	22.12
8	15600.00	42.4 AV	54.0	-11.6	1.04 H	261	20.28	22.12

ANTENNA POLARITY & TEST DISTANCE: VERTICAL AT 3 M

NO.	FREQ. (MHz)	EMISSION LEVEL (dBuV/m)	LIMIT (dBuV/m)	MARGIN (dB)	ANTENNA HEIGHT (m)	TABLE ANGLE (Degree)	RAW VALUE (dBuV)	CORRECTION FACTOR (dB/m)
1	5150.00	64.2 PK	74.0	-9.8	1.11 V	329	55.60	8.60
2	5150.00	48.8 AV	54.0	-5.2	1.11 V	329	40.20	8.60
3	*5200.00	114.2 PK			1.11 V	329	105.33	8.87
4	*5200.00	104.7 AV			1.11 V	329	95.83	8.87
5	#10400.00	59.4 PK	74.0	-14.6	1.10 V	360	44.22	15.18
6	#10400.00	45.9 AV	54.0	-8.1	1.10 V	360	30.72	15.18
7	15600.00	59.9 PK	74.0	-14.1	1.16 V	97	37.78	22.12
8	15600.00	47.0 AV	54.0	-7.0	1.16 V	97	24.88	22.12

REMARKS:

- Emission Level(dBuV/m) = Raw Value(dBuV) + Correction Factor(dB/m)
- Correction Factor(dB/m) = Antenna Factor(dB/m) + Cable Factor(dB)
– Pre-Amplifier Factor(dB)
- The other emission levels were very low against the limit.
- Margin value = Emission Level – Limit value
- " * ": Fundamental frequency.
- " # ": The radiated frequency is out of the restricted band.



A D T

CHANNEL	TX Channel 48	DETECTOR FUNCTION	Peak (PK)
FREQUENCY RANGE	1GHz ~ 40GHz		Average (AV)

ANTENNA POLARITY & TEST DISTANCE: HORIZONTAL AT 3 M

NO.	FREQ. (MHz)	EMISSION LEVEL (dBuV/m)	LIMIT (dBuV/m)	MARGIN (dB)	ANTENNA HEIGHT (m)	TABLE ANGLE (Degree)	RAW VALUE (dBuV)	CORRECTION FACTOR (dB/m)
1	5150.00	52.1 PK	74.0	-21.9	1.00 H	39	43.50	8.60
2	5150.00	40.8 AV	54.0	-13.2	1.00 H	39	32.20	8.60
3	*5240.00	104.6 PK			1.00 H	39	95.59	9.01
4	*5240.00	95.7 AV			1.00 H	39	86.69	9.01
5	5359.00	53.5 PK	74.0	-20.5	1.00 H	39	44.17	9.33
6	5359.00	42.2 AV	54.0	-11.8	1.00 H	39	32.87	9.33
7	#10480.00	53.9 PK	74.0	-20.1	1.22 H	21	38.10	15.80
8	#10480.00	42.3 AV	54.0	-11.7	1.22 H	21	26.50	15.80
9	15720.00	54.9 PK	74.0	-19.1	1.00 H	270	33.10	21.80
10	15720.00	42.2 AV	54.0	-11.8	1.00 H	270	20.40	21.80

ANTENNA POLARITY & TEST DISTANCE: VERTICAL AT 3 M

NO.	FREQ. (MHz)	EMISSION LEVEL (dBuV/m)	LIMIT (dBuV/m)	MARGIN (dB)	ANTENNA HEIGHT (m)	TABLE ANGLE (Degree)	RAW VALUE (dBuV)	CORRECTION FACTOR (dB/m)
1	5150.00	55.6 PK	74.0	-18.4	1.09 V	327	47.00	8.60
2	5150.00	46.6 AV	54.0	-7.4	1.09 V	327	38.00	8.60
3	*5240.00	114.2 PK			1.09 V	327	105.19	9.01
4	*5240.00	105.2 AV			1.09 V	327	96.19	9.01
5	5359.00	60.3 PK	74.0	-13.7	1.06 V	327	50.97	9.33
6	5359.00	51.9 AV	54.0	-2.1	1.06 V	327	42.57	9.33
7	#10480.00	59.4 PK	74.0	-14.6	1.08 V	360	43.60	15.80
8	#10480.00	45.9 AV	54.0	-8.1	1.08 V	360	30.10	15.80
9	15720.00	60.0 PK	74.0	-14.0	1.20 V	103	38.20	21.80
10	15720.00	47.0 AV	54.0	-7.0	1.20 V	103	25.20	21.80

REMARKS:

1. Emission Level(dBuV/m) = Raw Value(dBuV) + Correction Factor(dB/m)
2. Correction Factor(dB/m) = Antenna Factor(dB/m) + Cable Factor(dB)
– Pre-Amplifier Factor(dB)
3. The other emission levels were very low against the limit.
4. Margin value = Emission Level – Limit value
5. " * ": Fundamental frequency.
6. " # ": The radiated frequency is out of the restricted band.



A D T

802.11n (HT20)

CHANNEL	TX Channel 36	DETECTOR FUNCTION	Peak (PK)
FREQUENCY RANGE	1GHz ~ 40GHz		Average (AV)

ANTENNA POLARITY & TEST DISTANCE: HORIZONTAL AT 3 M

NO.	FREQ. (MHz)	EMISSION LEVEL (dBuV/m)	LIMIT (dBuV/m)	MARGIN (dB)	ANTENNA HEIGHT (m)	TABLE ANGLE (Degree)	RAW VALUE (dBuV)	CORRECTION FACTOR (dB/m)
1	5105.00	52.0 PK	74.0	-22.0	1.03 H	25	43.66	8.34
2	5105.00	40.7 AV	54.0	-13.3	1.03 H	25	32.36	8.34
3	5150.00	65.7 PK	74.0	-8.3	1.03 H	25	57.10	8.60
4	5150.00	47.2 AV	54.0	-6.8	1.03 H	25	38.60	8.60
5	*5180.00	101.1 PK			1.03 H	25	92.34	8.76
6	*5180.00	91.8 AV			1.03 H	25	83.04	8.76
7	#10360.00	54.1 PK	74.0	-19.9	1.17 H	7	38.56	15.54
8	#10360.00	42.6 AV	54.0	-11.4	1.17 H	7	27.06	15.54
9	15540.00	55.0 PK	74.0	-19.0	1.03 H	273	32.63	22.37
10	15540.00	42.3 AV	54.0	-11.7	1.03 H	273	19.93	22.37

ANTENNA POLARITY & TEST DISTANCE: VERTICAL AT 3 M

NO.	FREQ. (MHz)	EMISSION LEVEL (dBuV/m)	LIMIT (dBuV/m)	MARGIN (dB)	ANTENNA HEIGHT (m)	TABLE ANGLE (Degree)	RAW VALUE (dBuV)	CORRECTION FACTOR (dB/m)
1	5105.00	58.7 PK	74.0	-15.3	1.00 V	252	50.36	8.34
2	5105.00	47.2 AV	54.0	-6.8	1.00 V	252	38.86	8.34
3	5150.00	71.7 PK	74.0	-2.3	1.12 V	326	63.10	8.60
4	5150.00	53.4 AV	54.0	-0.6	1.12 V	326	44.80	8.60
5	*5180.00	110.8 PK			1.12 V	326	102.04	8.76
6	*5180.00	101.6 AV			1.12 V	326	92.84	8.76
7	#10360.00	59.4 PK	74.0	-14.6	1.05 V	360	43.86	15.54
8	#10360.00	46.0 AV	54.0	-8.0	1.05 V	360	30.46	15.54
9	15540.00	60.2 PK	74.0	-13.8	1.19 V	102	37.83	22.37
10	15540.00	47.2 AV	54.0	-6.8	1.19 V	102	24.83	22.37

REMARKS:

1. Emission Level(dBuV/m) = Raw Value(dBuV) + Correction Factor(dB/m)
2. Correction Factor(dB/m) = Antenna Factor(dB/m) + Cable Factor(dB)
– Pre-Amplifier Factor(dB)
3. The other emission levels were very low against the limit.
4. Margin value = Emission Level – Limit value
5. " * ": Fundamental frequency.
6. " # ": The radiated frequency is out of the restricted band.



A D T

CHANNEL	TX Channel 40	DETECTOR FUNCTION	Peak (PK)
FREQUENCY RANGE	1GHz ~ 40GHz		Average (AV)

ANTENNA POLARITY & TEST DISTANCE: HORIZONTAL AT 3 M

NO.	FREQ. (MHz)	EMISSION LEVEL (dBuV/m)	LIMIT (dBuV/m)	MARGIN (dB)	ANTENNA HEIGHT (m)	TABLE ANGLE (Degree)	RAW VALUE (dBuV)	CORRECTION FACTOR (dB/m)
1	5114.00	52.5 PK	74.0	-21.5	1.04 H	38	44.11	8.39
2	5114.00	41.2 AV	54.0	-12.8	1.04 H	38	32.81	8.39
3	5150.00	60.4 PK	74.0	-13.6	1.04 H	38	51.80	8.60
4	5150.00	39.7 AV	54.0	-14.3	1.04 H	38	31.10	8.60
5	*5200.00	103.4 PK			1.04 H	38	94.53	8.87
6	*5200.00	93.8 AV			1.04 H	38	84.93	8.87
7	#10400.00	53.8 PK	74.0	-20.2	1.28 H	17	38.62	15.18
8	#10400.00	42.1 AV	54.0	-11.9	1.28 H	17	26.92	15.18
9	15600.00	55.0 PK	74.0	-19.0	1.01 H	272	32.88	22.12
10	15600.00	42.1 AV	54.0	-11.9	1.01 H	272	19.98	22.12

ANTENNA POLARITY & TEST DISTANCE: VERTICAL AT 3 M

NO.	FREQ. (MHz)	EMISSION LEVEL (dBuV/m)	LIMIT (dBuV/m)	MARGIN (dB)	ANTENNA HEIGHT (m)	TABLE ANGLE (Degree)	RAW VALUE (dBuV)	CORRECTION FACTOR (dB/m)
1	5114.00	58.4 PK	74.0	-15.6	1.11 V	327	50.01	8.39
2	5114.00	47.0 AV	54.0	-7.0	1.11 V	327	38.61	8.39
3	5150.00	66.8 PK	74.0	-7.2	1.12 V	327	58.20	8.60
4	5150.00	46.2 AV	54.0	-7.8	1.12 V	327	37.60	8.60
5	*5200.00	113.2 PK			1.12 V	327	104.33	8.87
6	*5200.00	103.9 AV			1.12 V	327	95.03	8.87
7	#10400.00	59.7 PK	74.0	-14.3	1.07 V	360	44.52	15.18
8	#10400.00	46.0 AV	54.0	-8.0	1.07 V	360	30.82	15.18
9	15600.00	60.6 PK	74.0	-13.4	1.18 V	96	38.48	22.12
10	15600.00	47.3 AV	54.0	-6.7	1.18 V	96	25.18	22.12

REMARKS:

1. Emission Level(dBuV/m) = Raw Value(dBuV) + Correction Factor(dB/m)
2. Correction Factor(dB/m) = Antenna Factor(dB/m) + Cable Factor(dB)
– Pre-Amplifier Factor(dB)
3. The other emission levels were very low against the limit.
4. Margin value = Emission Level – Limit value
5. " * ": Fundamental frequency.
6. " # ": The radiated frequency is out of the restricted band.



A D T

CHANNEL	TX Channel 48	DETECTOR FUNCTION	Peak (PK)
FREQUENCY RANGE	1GHz ~ 40GHz		Average (AV)

ANTENNA POLARITY & TEST DISTANCE: HORIZONTAL AT 3 M

NO.	FREQ. (MHz)	EMISSION LEVEL (dBuV/m)	LIMIT (dBuV/m)	MARGIN (dB)	ANTENNA HEIGHT (m)	TABLE ANGLE (Degree)	RAW VALUE (dBuV)	CORRECTION FACTOR (dB/m)
1	5120.00	48.9 PK	74.0	-25.1	1.07 H	43	40.47	8.43
2	5120.00	40.7 AV	54.0	-13.3	1.07 H	43	32.27	8.43
3	5150.00	55.0 PK	74.0	-19.0	1.07 H	43	46.40	8.60
4	5150.00	41.5 AV	54.0	-12.5	1.07 H	43	32.90	8.60
5	*5240.00	104.2 PK			1.07 H	43	95.19	9.01
6	*5240.00	94.9 AV			1.07 H	43	85.89	9.01
7	5359.00	54.1 PK	74.0	-19.9	1.07 H	43	44.77	9.33
8	5359.00	46.7 AV	54.0	-7.3	1.07 H	43	37.37	9.33
9	#10480.00	53.6 PK	74.0	-20.4	1.24 H	22	37.80	15.80
10	#10480.00	42.2 AV	54.0	-11.8	1.24 H	22	26.40	15.80
11	15720.00	55.1 PK	74.0	-18.9	1.00 H	285	33.30	21.80
12	15720.00	42.4 AV	54.0	-11.6	1.00 H	285	20.60	21.80

ANTENNA POLARITY & TEST DISTANCE: VERTICAL AT 3 M

NO.	FREQ. (MHz)	EMISSION LEVEL (dBuV/m)	LIMIT (dBuV/m)	MARGIN (dB)	ANTENNA HEIGHT (m)	TABLE ANGLE (Degree)	RAW VALUE (dBuV)	CORRECTION FACTOR (dB/m)
1	5120.00	54.7 PK	74.0	-19.3	1.09 V	326	46.27	8.43
2	5120.00	46.3 AV	54.0	-7.7	1.09 V	326	37.87	8.43
3	5150.00	55.1 PK	74.0	-18.9	1.09 V	326	46.50	8.60
4	5150.00	41.6 AV	54.0	-12.4	1.09 V	326	33.00	8.60
5	*5240.00	113.9 PK			1.09 V	326	104.89	9.01
6	*5240.00	104.9 AV			1.09 V	326	95.89	9.01
7	5359.00	60.8 PK	74.0	-13.2	1.07 V	326	51.47	9.33
8	5359.00	53.2 AV	54.0	-0.8	1.07 V	326	43.87	9.33
9	#10480.00	59.1 PK	74.0	-14.9	1.06 V	360	43.30	15.80
10	#10480.00	45.5 AV	54.0	-8.5	1.06 V	360	29.70	15.80
11	15720.00	60.6 PK	74.0	-13.4	1.15 V	102	38.80	21.80
12	15720.00	47.4 AV	54.0	-6.6	1.15 V	102	25.60	21.80

REMARKS:

1. Emission Level(dBuV/m) = Raw Value(dBuV) + Correction Factor(dB/m)
2. Correction Factor(dB/m) = Antenna Factor(dB/m) + Cable Factor(dB)
– Pre-Amplifier Factor(dB)
3. The other emission levels were very low against the limit.
4. Margin value = Emission Level – Limit value
5. " * ": Fundamental frequency.
6. " # ": The radiated frequency is out of the restricted band.



A D T

802.11n (HT40)

CHANNEL	TX Channel 38	DETECTOR FUNCTION	Peak (PK)
FREQUENCY RANGE	1GHz ~ 40GHz		Average (AV)

ANTENNA POLARITY & TEST DISTANCE: HORIZONTAL AT 3 M

NO.	FREQ. (MHz)	EMISSION LEVEL (dBuV/m)	LIMIT (dBuV/m)	MARGIN (dB)	ANTENNA HEIGHT (m)	TABLE ANGLE (Degree)	RAW VALUE (dBuV)	CORRECTION FACTOR (dB/m)
1	5150.00	60.8 PK	74.0	-13.2	1.04 H	31	52.20	8.60
2	5150.00	46.9 AV	54.0	-7.1	1.04 H	31	38.30	8.60
3	*5190.00	97.8 PK			1.04 H	31	88.98	8.82
4	*5190.00	88.5 AV			1.04 H	31	79.68	8.82
5	#10380.00	53.4 PK	74.0	-20.6	1.19 H	20	38.03	15.37
6	#10380.00	41.8 AV	54.0	-12.2	1.19 H	20	26.43	15.37
7	15570.00	55.6 PK	74.0	-18.4	1.00 H	284	33.36	22.24
8	15570.00	42.8 AV	54.0	-11.2	1.00 H	284	20.56	22.24

ANTENNA POLARITY & TEST DISTANCE: VERTICAL AT 3 M

NO.	FREQ. (MHz)	EMISSION LEVEL (dBuV/m)	LIMIT (dBuV/m)	MARGIN (dB)	ANTENNA HEIGHT (m)	TABLE ANGLE (Degree)	RAW VALUE (dBuV)	CORRECTION FACTOR (dB/m)
1	5150.00	67.5 PK	74.0	-6.5	1.18 V	272	58.90	8.60
2	5150.00	53.3 AV	54.0	-0.7	1.18 V	272	44.70	8.60
3	*5190.00	106.2 PK			1.18 V	272	97.38	8.82
4	*5190.00	96.8 AV			1.18 V	272	87.98	8.82
5	#10380.00	58.6 PK	74.0	-15.4	1.03 V	360	43.23	15.37
6	#10380.00	45.2 AV	54.0	-8.8	1.03 V	360	29.83	15.37
7	15570.00	60.0 PK	74.0	-14.0	1.10 V	101	37.76	22.24
8	15570.00	47.1 AV	54.0	-6.9	1.10 V	101	24.86	22.24

REMARKS:

1. Emission Level(dBuV/m) = Raw Value(dBuV) + Correction Factor(dB/m)
2. Correction Factor(dB/m) = Antenna Factor(dB/m) + Cable Factor(dB)
– Pre-Amplifier Factor(dB)
3. The other emission levels were very low against the limit.
4. Margin value = Emission Level – Limit value
5. " * ": Fundamental frequency.
6. " # ": The radiated frequency is out of the restricted band.



CHANNEL	TX Channel 46	DETECTOR FUNCTION	Peak (PK)
FREQUENCY RANGE	1GHz ~ 40GHz		Average (AV)

ANTENNA POLARITY & TEST DISTANCE: HORIZONTAL AT 3 M

NO.	FREQ. (MHz)	EMISSION LEVEL (dBuV/m)	LIMIT (dBuV/m)	MARGIN (dB)	ANTENNA HEIGHT (m)	TABLE ANGLE (Degree)	RAW VALUE (dBuV)	CORRECTION FACTOR (dB/m)
1	*5230.00	100.3 PK			1.09 H	39	91.33	8.97
2	*5230.00	91.2 AV			1.09 H	39	82.23	8.97
3	5350.00	55.1 PK	74.0	-18.9	1.09 H	39	45.79	9.31
4	5350.00	45.1 AV	54.0	-8.9	1.09 H	39	35.79	9.31
5	#10460.00	53.3 PK	74.0	-20.7	1.22 H	34	37.66	15.64
6	#10460.00	41.9 AV	54.0	-12.1	1.22 H	34	26.26	15.64
7	15690.00	55.3 PK	74.0	-18.7	1.00 H	289	33.52	21.78
8	15690.00	42.7 AV	54.0	-11.3	1.00 H	289	20.92	21.78

ANTENNA POLARITY & TEST DISTANCE: VERTICAL AT 3 M

NO.	FREQ. (MHz)	EMISSION LEVEL (dBuV/m)	LIMIT (dBuV/m)	MARGIN (dB)	ANTENNA HEIGHT (m)	TABLE ANGLE (Degree)	RAW VALUE (dBuV)	CORRECTION FACTOR (dB/m)
1	*5230.00	108.6 PK			1.16 V	264	99.63	8.97
2	*5230.00	99.5 AV			1.16 V	264	90.53	8.97
3	5350.00	60.6 PK	74.0	-13.4	1.16 V	264	51.29	9.31
4	5350.00	50.7 AV	54.0	-3.3	1.16 V	264	41.39	9.31
5	#10460.00	59.7 PK	74.0	-14.3	1.05 V	360	44.06	15.64
6	#10460.00	46.3 AV	54.0	-7.7	1.05 V	360	30.66	15.64
7	15690.00	60.6 PK	74.0	-13.4	1.22 V	104	38.82	21.78
8	15690.00	47.3 AV	54.0	-6.7	1.22 V	104	25.52	21.78

REMARKS:

- Emission Level(dBuV/m) = Raw Value(dBuV) + Correction Factor(dB/m)
- Correction Factor(dB/m) = Antenna Factor(dB/m) + Cable Factor(dB)
– Pre-Amplifier Factor(dB)
- The other emission levels were very low against the limit.
- Margin value = Emission Level – Limit value
- " * ": Fundamental frequency.
- " # ": The radiated frequency is out of the restricted band.



A D T

802.11ac (VHT80)

CHANNEL	TX Channel 42	DETECTOR FUNCTION	Peak (PK)
FREQUENCY RANGE	1GHz ~ 40GHz		Average (AV)

ANTENNA POLARITY & TEST DISTANCE: HORIZONTAL AT 3 M

NO.	FREQ. (MHz)	EMISSION LEVEL (dBuV/m)	LIMIT (dBuV/m)	MARGIN (dB)	ANTENNA HEIGHT (m)	TABLE ANGLE (Degree)	RAW VALUE (dBuV)	CORRECTION FACTOR (dB/m)
1	5150.00	60.0 PK	74.0	-14.0	1.04 H	57	51.40	8.60
2	5150.00	47.3 AV	54.0	-6.7	1.04 H	57	38.70	8.60
3	*5210.00	94.6 PK			1.04 H	57	85.70	8.90
4	*5210.00	85.4 AV			1.04 H	57	76.50	8.90
5	5350.00	51.2 PK	74.0	-22.8	1.04 H	57	41.89	9.31
6	5350.00	39.9 AV	54.0	-14.1	1.04 H	57	30.59	9.31
7	#10420.00	53.2 PK	74.0	-20.8	1.27 H	22	37.87	15.33
8	#10420.00	42.0 AV	54.0	-12.0	1.27 H	22	26.67	15.33
9	15630.00	55.0 PK	74.0	-19.0	1.00 H	294	32.99	22.01
10	15630.00	42.4 AV	54.0	-11.6	1.00 H	294	20.39	22.01

ANTENNA POLARITY & TEST DISTANCE: VERTICAL AT 3 M

NO.	FREQ. (MHz)	EMISSION LEVEL (dBuV/m)	LIMIT (dBuV/m)	MARGIN (dB)	ANTENNA HEIGHT (m)	TABLE ANGLE (Degree)	RAW VALUE (dBuV)	CORRECTION FACTOR (dB/m)
1	5150.00	66.2 PK	74.0	-7.8	1.11 V	334	57.60	8.60
2	5150.00	53.5 AV	54.0	-0.5	1.11 V	334	44.90	8.60
3	*5210.00	102.9 PK			1.11 V	334	94.00	8.90
4	*5210.00	93.5 AV			1.11 V	334	84.60	8.90
5	5350.00	54.7 PK	74.0	-19.3	1.11 V	334	45.39	9.31
6	5350.00	43.3 AV	54.0	-10.7	1.11 V	334	33.99	9.31
7	#10420.00	59.3 PK	74.0	-14.7	1.11 V	360	43.97	15.33
8	#10420.00	45.6 AV	54.0	-8.4	1.11 V	360	30.27	15.33
9	15630.00	61.3 PK	74.0	-12.7	1.19 V	94	39.29	22.01
10	15630.00	47.9 AV	54.0	-6.1	1.19 V	94	25.89	22.01

REMARKS:

1. Emission Level(dBuV/m) = Raw Value(dBuV) + Correction Factor(dB/m)
2. Correction Factor(dB/m) = Antenna Factor(dB/m) + Cable Factor(dB)
– Pre-Amplifier Factor(dB)
3. The other emission levels were very low against the limit.
4. Margin value = Emission Level – Limit value
5. " * ": Fundamental frequency.
6. " # ": The radiated frequency is out of the restricted band.

4.3 TRANSMIT POWER MEASUREMENT

4.3.1 LIMITS OF TRANSMIT POWER MEASUREMENT

Frequency Band	Limit
5.15 – 5.25GHz	The lesser of 50mW (17dBm) or 4dBm + 10logB
5.25 – 5.35GHz	The lesser of 250mW (24dBm) or 11dBm + 10logB
5.47 – 5.725GHz	The lesser of 250mW (24dBm) or 11dBm + 10logB
5.725 – 5.825GHz	The lesser of 1W (30dBm) or 17dBm + 10logB

Note: Where B is the 26dB emission bandwidth in MHz.

Per KDB 662911 D01 Multiple Transmitter Output v01r02 Method of conducted output power measurement on IEEE 802.11 devices,

Array Gain = 0 dB (i.e., no array gain) for NANT ≤ 4;

Array Gain = 0 dB (i.e., no array gain) for channel widths ≥ 40 MHz for any NANT;

Array Gain = 5 log(NANT/NSS) dB or 3 dB, whichever is less for 20-MHz channel widths with NANT ≥ 5.

For power measurements on all other devices: Array Gain = 10 log(NANT/NSS) dB.

4.3.2 TEST INSTRUMENTS

FOR POWER OUTPUT MEASUREMENT

DESCRIPTION & MANUFACTURER	MODEL NO.	SERIAL NO.	CALIBRATED DATE	CALIBRATED UNTIL
Power meter Anritsu	ML2495A	0824006	May 20, 2013	May 19, 2014
Power sensor Anritsu	MA2411B	0738172	May 20, 2013	May 19, 2014

Note:

1. The calibration interval of the above test instruments is 12 months and the calibrations are traceable to NML/ROC and NIST/USA.
2. Tested date : Aug. 22, 2013



A D T

FOR 26dB OCCUPIED BANDWIDTH

DESCRIPTION & MANUFACTURER	MODEL NO.	SERIAL NO.	CALIBRATED DATE	CALIBRATED UNTIL
Spectrum Analyzer R&S	FSP 40	100036	Jan. 21, 2013	Jan. 20, 2014

Note:

1. The calibration interval of the above test instruments is 12 months and the calibrations are traceable to NML/ROC and NIST/USA.
2. Tested date : Aug. 22, 2013

4.3.3 TEST PROCEDURE

FOR POWER OUTPUT MEASUREMENT

Method PM is used to perform output power measurement, trigger and gating function of wide band power meter is enabled to measure max output power of TX on burst. Duty factor is not added to measured value.

FOR 26dB OCCUPIED BANDWIDTH

1. Set RBW = approximately 1% of the emission bandwidth.
2. Set the VBW > RBW.
3. Detector = Peak.
4. Trace mode = max hold.
5. Measure the maximum width of the emission that is 26 dB down from the peak of the emission. Compare this with the RBW setting of the analyzer. Readjust RBW and repeat measurement as needed until the RBW/EBW ratio is approximately 1%.

4.3.4 DEVIATION FROM TEST STANDARD

No deviation

4.3.5 TEST SETUP

FOR POWER OUTPUT MEASUREMENT

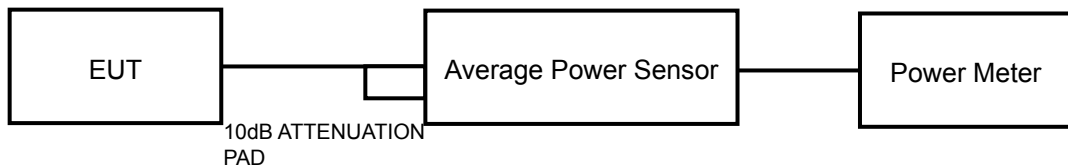

FOR 26dB OCCUPIED BANDWIDTH

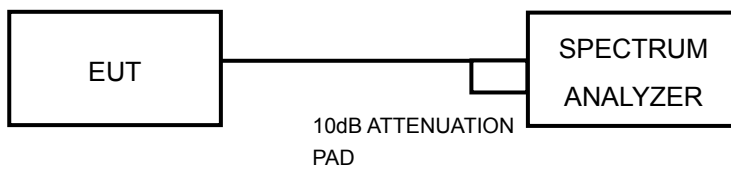

4.3.6 EUT OPERATING CONDITIONS

The software provided by client to enable the EUT under transmission condition continuously at specific channel frequencies individually.

4.3.7 TEST RESULTS

POWER OUTPUT: 802.11a

CHANNEL	CHANNEL FREQUENCY (MHz)	AVERAGE POWER (mW)	AVERAGE POWER (dBm)	POWER LIMIT (dBm)	PASS/FAIL
36	5180	41.400	16.17	17.00	PASS
40	5200	41.305	16.16	17.00	PASS
48	5240	41.210	16.15	17.00	PASS

26dB OCCUPIED BANDWIDTH:

CHANNEL	CHANNEL FREQUENCY (MHz)	26dBc BANDWIDTH (MHz)
36	5180	21.68
40	5200	21.60
48	5240	23.18

Note: For output power limitation is determined based on 26dBc bandwidth.

Power Limit = 4dBm + 10logB < Band 1 >			
Channel Number	Freq.(MHz)	Min. B(MHz)	Determined Limit (dBm)
36	5180	21.68	17.36 > 17
40	5200	21.60	17.34 > 17
48	5240	23.18	17.65 > 17



A D T

802.11n (HT20)

CHANNEL	CHANNEL FREQUENCY (MHz)	AVERAGE POWER (mW)	AVERAGE POWER (dBm)	POWER LIMIT (dBm)	PASS/FAIL
36	5180	41.020	16.13	17.00	PASS
40	5200	41.591	16.19	17.00	PASS
48	5240	40.832	16.11	17.00	PASS

26dB OCCUPIED BANDWIDTH:

CHANNEL	CHANNEL FREQUENCY (MHz)	26dBc BANDWIDTH (MHz)
36	5180	22.97
40	5200	22.67
48	5240	22.54

Note: For output power limitation is determined based on 26dBc bandwidth.

Power Limit = 4dBm + 10logB < Band 1 >			
Channel Number	Freq.(MHz)	Min. B(MHz)	Determined Limit (dBm)
36	5180	22.97	17.61 > 17
40	5200	22.67	17.55 > 17
48	5240	22.54	17.52 > 17



A D T

802.11n (HT40)

CHANNEL	CHANNEL FREQUENCY (MHz)	AVERAGE POWER (mW)	AVERAGE POWER (dBm)	POWER LIMIT (dBm)	PASS/FAIL
38	5190	48.753	16.88	17.00	PASS
46	5230	46.238	16.65	17.00	PASS

26dB OCCUPIED BANDWIDTH:

CHANNEL	CHANNEL FREQUENCY (MHz)	26dBc BANDWIDTH (MHz)
38	5190	45.82
46	5230	45.94

Note: For output power limitation is determined based on 26dBc bandwidth.

Power Limit = $4\text{dBm} + 10\log B$ < Band 1 >			
Channel Number	Freq.(MHz)	Min. B(MHz)	Determined Limit (dBm)
38	5190	45.82	20.61 > 17
46	5230	45.94	20.62 > 17



A D T

802.11ac (VHT80)

CHANNEL	CHANNEL FREQUENCY (MHz)	AVERAGE POWER (mW)	AVERAGE POWER (dBm)	POWER LIMIT (dBm)	PASS/FAIL
42	5210	25.704	14.10	17.00	PASS

26dB OCCUPIED BANDWIDTH:

CHANNEL	CHANNEL FREQUENCY (MHz)	26dBc BANDWIDTH (MHz)
42	5210	84.79

Note: For output power limitation is determined based on 26dBc bandwidth.

Power Limit = $4\text{dBm} + 10\log B$ < Band 1 >			
Channel Number	Freq.(MHz)	Min. B(MHz)	Determined Limit (dBm)
42	5210	84.79	23.28 > 17



A D T

4.4 PEAK POWER SPECTRAL DENSITY MEASUREMENT

4.4.1 LIMITS OF PEAK POWER SPECTRAL DENSITY MEASUREMENT

Frequency Band	Limit
5.15 ~ 5.25GHz	4dBm
5.25 ~ 5.35GHz	11dBm
5.47 – 5.725GHz	11dBm
5.725 ~ 5.825GHz	17dBm

4.4.2 TEST INSTRUMENTS

DESCRIPTION & MANUFACTURER	MODEL NO.	SERIAL NO.	CALIBRATED DATE	CALIBRATED UNTIL
Spectrum Analyzer R&S	FSP 40	100036	Jan. 21, 2013	Jan. 20, 2014

Note:

1. The calibration interval of the above test instruments is 12 months and the calibrations are traceable to NML/ROC and NIST/USA.
2. Tested date : Aug. 22, 2013

4.4.3 TEST PROCEDURES

1. Set span to encompass the entire emission bandwidth (EBW) of the signal.
2. Set RBW = 1 MHz, Set VBW \geq 3 MHz, Detector = RMS
3. Sweep time = auto, trigger set to “free run”.
4. Trace average at least 100 traces in power averaging mode.
5. Record the max value and for duty cycle of test signal is < 98% add 10 log (1/duty cycle)

4.4.4 DEVIATION FROM TEST STANDARD

No deviation



A D T

4.4.5 TEST SETUP

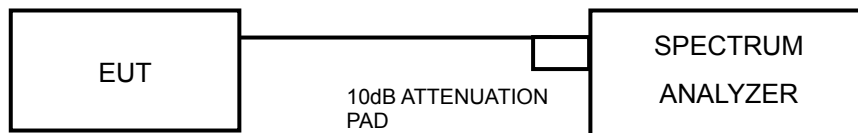

4.4.6 EUT OPERATING CONDITIONS

Same as 4.3.6



4.4.7 TEST RESULTS

802.11a

CHANNEL	CHANNEL FREQUENCY (MHz)	PSD (dBm)	MAXIMUM LIMIT (dBm)	PASS/FAIL
36	5180	3.05	4	PASS
40	5200	2.72	4	PASS
48	5240	2.63	4	PASS

802.11n (HT20)

CHANNEL	CHANNEL FREQUENCY (MHz)	PSD (dBm)	MAXIMUM LIMIT (dBm)	PASS/FAIL
36	5180	3.77	4	PASS
40	5200	3.61	4	PASS
48	5240	3.35	4	PASS

802.11n (HT40)

CHANNEL	CHANNEL FREQUENCY (MHz)	PSD (dBm)	MAXIMUM LIMIT (dBm)	PASS/FAIL
38	5190	0.08	4	PASS
46	5230	-0.28	4	PASS

802.11ac (VHT80)

CHANNEL	CHANNEL FREQUENCY (MHz)	PSD (dBm)	MAXIMUM LIMIT (dBm)	PASS/FAIL
42	5210	-4.59	4	PASS

NOTE: 1. Method 1 of power density measurement of KDB 662911 is using for calculating total power density. Total power density is summing entire spectra across corresponding frequency bins on the various outputs by computer.

4.5 PEAK POWER EXCURSION MEASUREMENT

4.5.1 LIMITS OF PEAK POWER EXCURSION MEASUREMENT

Shall not exceed 13 dB

4.5.2 TEST INSTRUMENTS

DESCRIPTION & MANUFACTURER	MODEL NO.	SERIAL NO.	CALIBRATED DATE	CALIBRATED UNTIL
Spectrum Analyzer R&S	FSP 40	100036	Jan. 21, 2013	Jan. 20, 2014

Note:

1. The calibration interval of the above test instruments is 12 months and the calibrations are traceable to NML/ROC and NIST/USA.
2. Tested date : Aug. 22, 2013

4.5.3 TEST PROCEDURE

1. Set RBW = 1 MHz, VBW \geq 3 MHz, Detector = peak.
2. Trace mode = max-hold. Allow the sweeps to continue until the trace stabilizes.
3. Use the peak search function to find the peak of the spectrum.
4. Measure the PPSD.
5. Compute the ratio of the maximum of the peak-max-hold spectrum to the PPSD.

4.5.4 DEVIATION FROM TEST STANDARD

No deviation

4.5.5 TEST SETUP

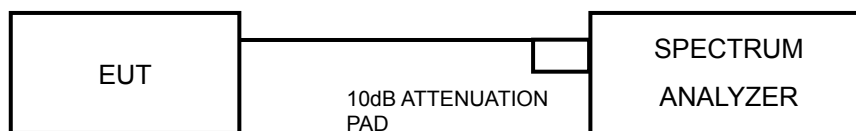

4.5.6 EUT OPERATING CONDITIONS

The software provided by client to enable the EUT under transmission condition continuously at specific channel frequencies individually.

4.5.7 TEST RESULTS

MODULATION MODE	MODULATION TYPE	CHANNEL FREQUENCY (MHz)	PEAK VALUE (dBm)	PPSD (dBm)	PEAK EXCURSION (dB)	LIMIT (dB)	PASS/ FAIL
802.11a	BPSK	5240	10.17	2.63	7.54	13	PASS
	QPSK		11.76	2.48	9.28	13	PASS
	16QAM		10.8	2.39	8.41	13	PASS
	64QAM		11.6	2.39	9.21	13	PASS
802.11n (40MHz)	BPSK	5240	11.06	3.35	7.71	13	PASS
	QPSK		11.13	3.03	8.1	13	PASS
	16QAM		12.13	3.09	9.04	13	PASS
	64QAM		12.74	3.12	9.62	13	PASS
802.11n (20MHz)	BPSK	5230	7.61	-0.28	7.89	13	PASS
	QPSK		8.5	-0.12	8.62	13	PASS
	16QAM		8.77	-0.33	9.1	13	PASS
	64QAM		9.32	-0.41	9.73	13	PASS
802.11ac (80MHz)	BPSK	5210	3.52	-4.59	8.11	13	PASS
	QPSK		3.97	-4.47	8.44	13	PASS
	16QAM		4.57	-4.57	9.14	13	PASS
	64QAM		3.63	-4.74	8.37	13	PASS
	256QAM		4.50	-4.53	9.03	13	PASS

4.6 FREQUENCY STABILITY

4.6.1 LIMITS OF FREQUENCY STABILITY MEASUREMENT

The frequency of the carrier signal shall be maintained within band of operation

4.6.2 TEST INSTRUMENTS

DESCRIPTION & MANUFACTURER	MODEL NO.	SERIAL NO.	CALIBRATED DATE	CALIBRATED UNTIL
Spectrum Analyzer R&S	FSP 40	100036	Jan. 21, 2013	Jan. 20, 2014
Temperature & Humidity Chamber GIANTFORCE	GTH-150-40 -SP-AR	MAA0812-008	Jan. 17, 2013	Jan. 16, 2014

Note:

1. The calibration interval of the above test instruments is 12 months and the calibrations are traceable to NML/ROC and NIST/USA.
2. Tested date : Aug. 22, 2013

4.6.3 TEST PROCEDURE

1. The EUT was placed inside the environmental test chamber and powered by nominal AC voltage.
2. Turn the EUT on and couple its output to a spectrum analyzer.
3. Turn the EUT off and set the chamber to the highest temperature specified.
4. Allow sufficient time (approximately 30 min) for the temperature of the chamber to stabilize, turn the EUT on and measure the operating frequency after 2, 5, and 10 minutes.
5. Repeat step 2 and 3 with the temperature chamber set to the lowest temperature.
6. The test chamber was allowed to stabilize at +20 degree C for a minimum of 30 minutes. The supply voltage was then adjusted on the EUT from 85% to 115% and the frequency record.

4.6.4 DEVIATION FROM TEST STANDARD

No deviation

4.6.5 TEST SETUP

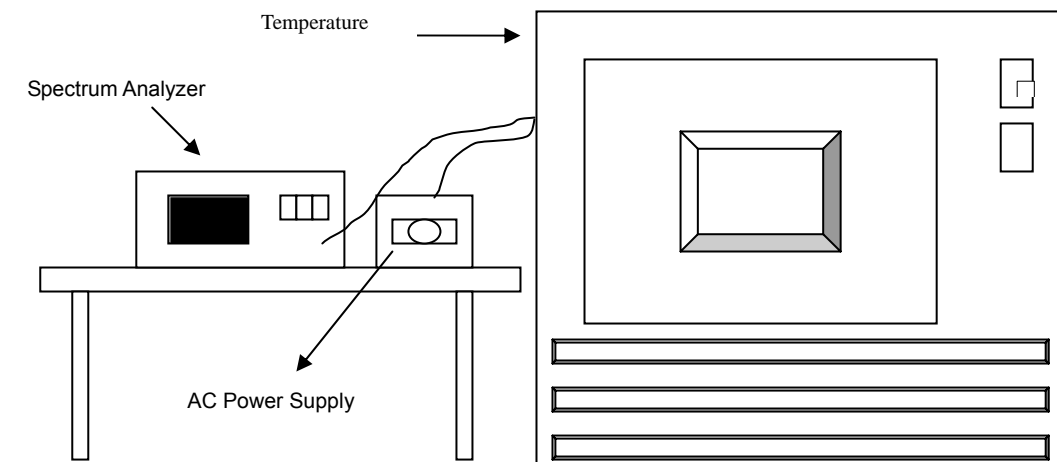

4.6.6 EUT OPERATING CONDITION

Set the EUT transmit at un-modulation mode to test frequency stability.



A D T

4.6.7 TEST RESULTS

FREQUENCY STABILITY VERSUS TEMP.									
OPERATING FREQUENCY: 5240MHz									
TEMP. (°C)	POWER SUPPLY (Vac)	0 MINUTE		2 MINUTE		5 MINUTE		10 MINUTE	
		Measured Frequency	Frequency Drift	Measured Frequency	Frequency Drift	Measured Frequency	Frequency Drift	Measured Frequency	Frequency Drift
		(MHz)	%	(MHz)	%	(MHz)	%	(MHz)	%
50	120	5240.018	0.00034	5240.0178	0.00034	5240.0141	0.00027	5240.0102	0.00019
40	120	5240.02	0.00038	5240.0244	0.00047	5240.0249	0.00048	5240.0177	0.00034
30	120	5239.9846	-0.00029	5239.9862	-0.00026	5239.989	-0.00021	5239.9862	-0.00026
20	120	5239.9848	-0.00029	5239.9873	-0.00024	5239.9898	-0.00019	5239.9888	-0.00021
10	120	5240.0225	0.00043	5240.0243	0.00046	5240.0194	0.00037	5240.023	0.00044
0	120	5239.9851	-0.00028	5239.9928	-0.00014	5239.9909	-0.00017	5239.9912	-0.00017
-10	120	5240.0016	0.00003	5240.0022	0.00004	5240.0075	0.00014	5240.0023	0.00004
-20	120	5240.0208	0.00040	5240.0187	0.00036	5240.0184	0.00035	5240.018	0.00034
-30	120	5239.9789	-0.00040	5239.9749	-0.00048	5239.9776	-0.00043	5239.9763	-0.00045

FREQUENCY STABILITY VERSUS VOLTAGE									
OPERATING FREQUENCY: 5240MHz									
TEMP. (°C)	POWER SUPPLY (Vac)	0 MINUTE		2 MINUTE		5 MINUTE		10 MINUTE	
		Measured Frequency	Frequency Drift	Measured Frequency	Frequency Drift	Measured Frequency	Frequency Drift	Measured Frequency	Frequency Drift
		(MHz)	%	(MHz)	%	(MHz)	%	(MHz)	%
20	138	5239.9848	-0.00029	5239.9865	-0.00026	5239.9899	-0.00019	5239.9893	-0.00020
	120	5239.9848	-0.00029	5239.9873	-0.00024	5239.9898	-0.00019	5239.9888	-0.00021
	102	5239.9854	-0.00028	5239.9872	-0.00024	5239.9888	-0.00021	5239.9892	-0.00021

5. PHOTOGRAPHS OF THE TEST CONFIGURATION

Please refer to the attached file (Test Setup Photo).



6. INFORMATION ON THE TESTING LABORATORIES

We, Bureau Veritas Consumer Products Services (H.K.) Ltd., Taoyuan Branch, were founded in 1988 to provide our best service in EMC, Radio, Telecom and Safety consultation. Our laboratories are accredited and approved according to ISO/IEC 17025.

If you have any comments, please feel free to contact us at the following:

Linko EMC/RF Lab:

Tel: 886-2-26052180

Fax: 886-2-26052943

Hsin Chu EMC/RF Lab:

Tel: 886-3-5935343

Fax: 886-3-5935342

Hwa Ya EMC/RF/Safety/Telecom Lab:

Tel: 886-3-3183232

Fax: 886-3-3270892

Email: service.adt@tw.bureauveritas.com

Web Site: www.bureauveritas-adt.com

The address and road map of all our labs can be found in our web site also.



A D T

7.APPENDIX A - MODIFICATIONS RECORDERS FOR ENGINEERING CHANGES TO THE EUT BY THE LAB

No modifications were made to the EUT by the lab during the test.

--- END ---