



A D T

FCC TEST REPORT

REPORT NO.: RF111115E02

MODEL NO.: DIR-618

FCC ID: KA2IR618B1

RECEIVED: Nov. 15, 2011

TESTED: Dec. 02 to 12, 2011

ISSUED: Dec. 21, 2011

APPLICANT: D-Link Corporation

ADDRESS: No.289, Sinhu 3rd Rd., Neihu District, Taipei
City 114, Taiwan, R.O.C.

ISSUED BY: Bureau Veritas Consumer Products Services
(H.K.) Ltd., Taoyuan Branch Hsin Chu Laboratory

LAB ADDRESS : No. 81-1, Lu Liao Keng, 9th Ling,Wu Lung Tsuen,
Chiung Lin Hsiang, Hsin Chu Hsien 307, Taiwan

TEST LOCATION (1): No. 81-1, Lu Liao Keng, 9th Ling,Wu Lung Tsuen,
Chiung Lin Hsiang, Hsin Chu Hsien 307, Taiwan

TEST LOCATION (2): No. 49, Ln. 206, Wende Rd., Shangshan Tsuen,
Chiung Lin Hsiang, Hsin Chu Hsien 307, Taiwan

This test report consists of 81 pages in total. It may be duplicated completely for legal use with the approval of the applicant. It should not be reproduced except in full, without the written approval of our laboratory. The client should not use it to claim product certification, approval, or endorsement by TAF or any government agencies. The test results in the report only apply to the tested sample.





A D T

Table of Contents

RELEASE CONTROL RECORD	4
1. CERTIFICATION	5
2. SUMMARY OF TEST RESULTS	6
2.1 MEASUREMENT UNCERTAINTY	7
3. GENERAL INFORMATION	8
3.1 GENERAL DESCRIPTION OF EUT	8
3.2 DESCRIPTION OF TEST MODES	10
3.2.1 TEST MODE APPLICABILITY AND TESTED CHANNEL DETAIL	11
3.3 GENERAL DESCRIPTION OF APPLIED STANDARDS	14
3.4 DESCRIPTION OF SUPPORT UNITS.....	15
3.5 CONFIGURATION OF SYSTEM UNDER TEST	16
4. TEST TYPES AND RESULTS	17
4.1 CONDUCTED EMISSION MEASUREMENT	17
4.1.1 LIMITS OF CONDUCTED EMISSION MEASUREMENT	17
4.1.2 TEST INSTRUMENTS.....	17
4.1.3 TEST PROCEDURES	18
4.1.4 DEVIATION FROM TEST STANDARD	18
4.1.5 TEST SETUP	19
4.1.6 EUT OPERATING CONDITIONS	19
4.1.7 TEST RESULTS (MODE 1)	20
4.1.8 TEST RESULTS (MODE 2)	22
4.2 RADIATED EMISSION MEASUREMENT	24
4.2.1 LIMITS OF RADIATED EMISSION MEASUREMENT	24
4.2.2 TEST INSTRUMENTS.....	25
4.2.3 TEST PROCEDURES	26
4.2.4 DEVIATION FROM TEST STANDARD	26
4.2.5 TEST SETUP	27
4.2.6 EUT OPERATING CONDITIONS	27
4.2.7 TEST RESULTS	28
4.3 6dB BANDWIDTH MEASUREMENT	57
4.3.1 LIMITS OF 6dB BANDWIDTH MEASUREMENT	57
4.3.2 TEST INSTRUMENTS.....	57
4.3.3 TEST PROCEDURE.....	57
4.3.4 DEVIATION FROM TEST STANDARD	57
4.3.5 TEST SETUP	57
4.3.6 EUT OPERATING CONDITIONS	57
4.3.7 TEST RESULTS	58
4.4 MAXIMUM PEAK OUTPUT POWER.....	62
4.4.1 LIMITS OF MAXIMUM PEAK OUTPUT POWER MEASUREMENT	62
4.4.2 INSTRUMENTS.....	62



A D T

4.4.3	TEST PROCEDURES	62
4.4.4	DEVIATION FROM TEST STANDARD	62
4.4.5	TEST SETUP	62
4.4.6	EUT OPERATING CONDITIONS	62
4.4.7	TEST RESULTS	64
4.5	POWER SPECTRAL DENSITY MEASUREMENT	66
4.5.1	LIMITS OF POWER SPECTRAL DENSITY MEASUREMENT	66
4.5.2	TEST INSTRUMENTS.....	66
4.5.3	TEST PROCEDURE.....	66
4.5.4	DEVIATION FROM TEST STANDARD	66
4.5.5	TEST SETUP	66
4.5.6	EUT OPERATING CONDITION.....	66
4.5.7	TEST RESULTS	67
4.6	CONDUCTED OUT-BAND EMISSION MEASUREMENT	71
4.6.1	LIMITS OF CONDUCTED OUT-BAND EMISSION MEASUREMENT.....	71
4.6.2	TEST INSTRUMENTS.....	71
4.6.3	TEST PROCEDURE.....	71
4.6.4	DEVIATION FROM TEST STANDARD	71
4.6.5	EUT OPERATING CONDITION.....	71
4.6.6	TEST RESULTS	71
5.	INFORMATION ON THE TESTING LABORATORIES	80
6.	APPENDIX A - MODIFICATIONS RECORDERS FOR ENGINEERING CHANGES TO THE EUT BY THE LAB.....	81



A D T

RELEASE CONTROL RECORD

ISSUE NO.	REASON FOR CHANGE	DATE ISSUED
RF111115E02	Original release	Dec. 21, 2011



A D T

1. CERTIFICATION

PRODUCT: Wireless N Router
BRAND NAME: D-Link
MODEL NO.: DIR-618
TEST SAMPLE: MASS-PRODUCTION
APPLICANT: D-Link Corporation
TESTED: Dec. 02 to 12, 2011
STANDARDS: FCC Part 15, Subpart C (Section 15.247)
ANSI C63.4-2003
ANSI C63.10-2009

The above equipment (Model: DIR-618) has been tested by **Bureau Veritas Consumer Products Services (H.K.) Ltd., Taoyuan Branch**, and found compliance with the requirement of the above standards. The test record, data evaluation & Equipment Under Test (EUT) configurations represented herein are true and accurate accounts of the measurements of the sample's EMC characteristics under the conditions specified in this report.

PREPARED BY : Midoli Peng, **DATE:** Dec. 21, 2011
(Midoli Peng, Specialist)

APPROVED BY : May Chen, **DATE:** Dec. 21, 2011
(May Chen, Deputy Manager)

2. SUMMARY OF TEST RESULTS

The EUT has been tested according to the following specifications:

For 2.4GHz, 2412~2462MHz Band

APPLIED STANDARD: FCC Part 15, Subpart C			
Standard Section	Test Type and Limit	Result	Remark
15.207	AC Power Conducted Emission	PASS	Meet the requirement of limit. Minimum passing margin is -6.56dB at 23.129MHz
15.247(a)(2)	Spectrum Bandwidth of a Direct Sequence Spread Spectrum System Limit: min. 500kHz	PASS	Meet the requirement of limit.
15.247(b)	Maximum Peak Output Power Limit: max. 30dBm	PASS	Meet the requirement of limit.
15.247(d)	Radiated Emissions Limit: Table 15.209	PASS	Meet the requirement of limit. Minimum passing margin is -0.5dB at 2390.0MHz & 2359.8MHz
15.247(e)	Power Spectral Density Limit: max. 8dBm	PASS	Meet the requirement of limit.
15.247(d)	Conducted Out-Band Emission Measurement Limit: 20dB less than the peak value of fundamental frequency	PASS	Meet the requirement of limit.
15.203	Antenna Requirement	PASS	No antenna connector is used.



A D T

2.1 MEASUREMENT UNCERTAINTY

Where relevant, the following measurement uncertainty levels have been estimated for tests performed on the EUT as specified in CISPR 16-4-2:

This uncertainty represents an expanded uncertainty expressed at approximately the 95% confidence level using a coverage factor of $k=2$.

Measurement	Value
Conducted emissions	2.45 dB
Radiated emissions (30MHz-1GHz)	3.89 dB
Radiated emissions (1GHz -18GHz)	2.19 dB
Radiated emissions (18GHz -40GHz)	2.56 dB



A D T

3. GENERAL INFORMATION

3.1 GENERAL DESCRIPTION OF EUT

PRODUCT	Wireless N Router
MODEL NO.	DIR-618
FCC ID	KA2IR618B1
POWER SUPPLY	DC 12V from power adapter
MODULATION TYPE	CCK, DQPSK, DBPSK for DSSS 64QAM, 16QAM, QPSK, BPSK for OFDM
MODULATION TECHNOLOGY	DSSS, OFDM
TRANSFER RATE	802.11b: up to 11Mbps 802.11g: up to 54Mbps 802.11n (20MHz, 800ns GI): up to 130Mbps 802.11n (40MHz, 800ns GI): up to 270Mbps 802.11n (20MHz, 400ns GI): up to 144.444Mbps 802.11n (40MHz, 400ns GI): up to 300Mbps
OPERATING FREQUENCY	2.412 ~ 2.462GHz
NUMBER OF CHANNEL	11 for 802.11b, 802.11g, 802.11n (20MHz) 7 for 802.11n (40MHz)
MAXIMUM OUTPUT POWER	802.11b: 323.6mW 802.11g: 407.4mW 802.11n (20MHz): 580.6mW 802.11n (40MHz): 533.9mW
ANTENNA TYPE	Please see note
DATA CABLE	NA
I/O PORTS	INTERNET port x 1 LAN (Ethernet) (10, 100Mbps) port x 4
ASSOCIATED DEVICES	Adapter x 1

NOTE:

1. There are two antennas provided to this EUT, please refer to the following table:

Transmitter Circuit	Manufacturer	Model No.	Antenna Type	Gain (dBi)	Antenna Connector
Chain (0)	WHA YU GROUP	C037-511127-A (SSR-11747)	Dipole	4.705	SMA Plug Reverse
Chain (1)	WHA YU GROUP	C037-511127-A (SSR-11747)	Dipole	4.705	SMA Plug Reverse

2. The EUT must be supplied with a power adapter and following two different models could be chosen as following table:

No.	Brand	Model No.	Spec.
1	D-Link	AMS9-1201000FU2	Input: 100-240V, 0.5A, 50/60Hz Output: 12V, 1.0A DC output cable (unshielded, 1.25m)
2	D-Link	CAP012121 US	Input: 100-240V, 0.35A, 47-63Hz Output: 12.0V, 1.0A DC output cable (unshielded, 1.25m)

From the above adapters, the radiated emissions worse case was found in the **adapter 1**. Therefore only the test data of the adapter was recorded in this report.

3. The EUT is 2 * 2 spatial MIMO (2Tx & 2Rx) without beam forming function. The 11b and 11g legacy mode is limited to single transmitter only.
4. When the EUT operating in 802.11n, the software operation, which is defined by manufacturer, MCS (Modulation and Coding Schemes) from 0 to 15.
5. The above EUT information was declared by the manufacturer and for more detailed features description, please refer to the manufacturer's specifications or User's.

3.2 DESCRIPTION OF TEST MODES

Operated in 2400 ~ 2483.5MHz band:

Eleven channels are provided for 802.11b, 802.11g, 802.11n (20MHz):

CHANNEL	FREQUENCY	CHANNEL	FREQUENCY
1	2412MHz	7	2442MHz
2	2417MHz	8	2447MHz
3	2422MHz	9	2452MHz
4	2427MHz	10	2457MHz
5	2432MHz	11	2462MHz
6	2437MHz		

Seven channels are provided for 802.11n (40MHz):

CHANNEL	FREQUENCY	CHANNEL	FREQUENCY
3	2422MHz	7	2442MHz
4	2427MHz	8	2447MHz
5	2432MHz	9	2452MHz
6	2437MHz		

3.2.1 TEST MODE APPLICABILITY AND TESTED CHANNEL DETAIL

EUT CONFIGURE MODE	APPLICABLE TO					DESCRIPTION
	PLC	RE < 1G	RE ≥ 1G	APCM	OB	
1	√	√	√	√	√	With adapter 1
2	√	-	-	-	-	With adapter 2

Where **PLC**: Power Line Conducted Emission **RE < 1G**: Radiated Emission below 1GHz
RE ≥ 1G: Radiated Emission above 1GHz **APCM**: Antenna Port Conducted Measurement
OB: Conducted Out-Band Emission Measurement

ANTENNA COMBINATION MODE:

COMBINATION MODE	OPERATION MODE	TX CHAIN(0)	TX CHAIN(1)
A	802.11 b	√	-
B	802.11 g	√	-
C	802.11n(20MHz) for MCS0~7	√	-
D	802.11n(20MHz) for MCS8~15	√	√
E	802.11n(40MHz) for MCS0~7	√	-
F	802.11n(40MHz) for MCS8~15	√	√

Note: 1. The above information was declared by manufacturer and for more detailed features description, please refer to the manufacturer's specifications or user's manual.

POWER LINE CONDUCTED EMISSION TEST:

- Pre-Scan has been conducted to determine the worst-case mode from all possible combinations between available modulations, data rates and antenna ports (if EUT with antenna diversity architecture).
- Following channel(s) was (were) selected for the final test as listed below.

MODE	AVAILABLE CHANNEL	TESTED CHANNEL	MODULATION TECHNOLOGY	MODULATION TYPE	DATA RATE (Mbps)	COMBINATION
802.11n (20MHz)	1 to 11	6	OFDM	BPSK	13	D



A D T

RADIATED EMISSION TEST (BELOW 1 GHz):

- Pre-Scan has been conducted to determine the worst-case mode from all possible combinations between available modulations, data rates and antenna ports (if EUT with antenna diversity architecture).
- Following channel(s) was (were) selected for the final test as listed below.

MODE	AVAILABLE CHANNEL	TESTED CHANNEL	MODULATION TECHNOLOGY	MODULATION TYPE	DATA RATE (Mbps)	COMBINATION
802.11n (20MHz)	1 to 11	6	OFDM	BPSK	13	D

RADIATED EMISSION TEST (ABOVE 1 GHz):

- Pre-Scan has been conducted to determine the worst-case mode from all possible combinations between available modulations, data rates and antenna ports (if EUT with antenna diversity architecture).
- Following channel(s) was (were) selected for the final test as listed below.

MODE	AVAILABLE CHANNEL	TESTED CHANNEL	MODULATION TECHNOLOGY	MODULATION TYPE	DATA RATE (Mbps)	COMBINATION
802.11b	1 to 11	1, 6, 11	DSSS	DBPSK	1	A
802.11g	1 to 11	1, 6, 11	OFDM	BPSK	6	B
802.11n (20MHz)	1 to 11	1, 6, 11	OFDM	BPSK	13	D
802.11n (40MHz)	3 to 9	3, 6, 9	OFDM	BPSK	27	F

ANTENNA PORT CONDUCTED MEASUREMENT:

- This item includes all test value of each mode, but only includes spectrum plot of worst value of each mode.
- Pre-Scan has been conducted to determine the worst-case mode from all possible combinations between available modulations, data rates and antenna ports (if EUT with antenna diversity architecture).
- Following channel(s) was (were) selected for the final test as listed below.

MODE	AVAILABLE CHANNEL	TESTED CHANNEL	MODULATION TECHNOLOGY	MODULATION TYPE	DATA RATE (Mbps)	COMBINATION
802.11b	1 to 11	1, 6, 11	DSSS	DBPSK	1	A
802.11g	1 to 11	1, 6, 11	OFDM	BPSK	6	B
802.11n (20MHz)	1 to 11	1, 6, 11	OFDM	BPSK	13	D
802.11n (40MHz)	3 to 9	3, 6, 9	OFDM	BPSK	27	F



A D T

CONDUCTED OUT-BAND EMISSION MEASUREMENT:

- Pre-Scan has been conducted to determine the worst-case mode from all possible combinations between available modulations, data rates and antenna ports (if EUT with antenna diversity architecture).
- Following channel(s) was (were) selected for the final test as listed below.

MODE	AVAILABLE CHANNEL	TESTED CHANNEL	MODULATION TECHNOLOGY	MODULATION TYPE	DATA RATE (Mbps)	COMBINATION MODE
802.11b	1 to 11	1, 11	DSSS	DBPSK	1	A
802.11g	1 to 11	1, 11	OFDM	BPSK	6	B
802.11n (20MHz)	1 to 11	1, 11	OFDM	BPSK	13	D
802.11n (40MHz)	3 to 9	3, 9	OFDM	BPSK	27	F

TEST CONDITION:

APPLICABLE TO	ENVIRONMENTAL CONDITIONS	INPUT POWER	TESTED BY
PLC	23deg. C, 69%RH	120Vac, 60Hz	Kyle Huang
RE<1G	17deg. C, 63%RH	120Vac, 60Hz	Kent Liu
RE ³ 1G	15deg. C, 61%RH	120Vac, 60Hz	Even Huang
APCM	25deg. C, 60%RH	120Vac, 60Hz	Ken Liu
OB	25deg. C, 60%RH	120Vac, 60Hz	Ken Liu

3.3 GENERAL DESCRIPTION OF APPLIED STANDARDS

The EUT is a RF product. According to the specifications of the manufacturer, it must comply with the requirements of the following standards:

FCC Part 15, Subpart C. (15.247)

ANSI C63.4-2003

ANSI C63.10-2009

All test items have been performed and recorded as per the above standards.

NOTE: The EUT is also considered as a kind of computer peripheral, because the connection to computer is necessary for typical use. It has been verified to comply with the requirements of FCC Part 15, Subpart B, Class B (DoC). The test report has been issued separately.



A D T

3.4 DESCRIPTION OF SUPPORT UNITS

The EUT has been tested as an independent unit together with other necessary accessories or support units. The following support units or accessories were used to form a representative test configuration during the tests.

No.	Product	Brand	Model No.	Serial No.	FCC ID
1	NOTEBOOK COMPUTER	DELL	PP32LA	HSLB32S	FCC DoC
2	NOTEBOOK COMPUTER (For conducted emission test)	DELL	PP18L	12252644560	FCC DoC
	NOTEBOOK COMPUTER (For other test items)	DELL	PP32LA	GSLB32S	FCC DoC
3	HUB	ZyXEL	ES-116P	S060H02000215	FCC DoC

No.	SIGNAL CABLE DESCRIPTION OF THE ABOVE SUPPORT UNITS
1	UTP Cable (10m)
2	UTP Cable (10m)
3	UTP Cable (10m)

NOTE: All power cords of the above support units are non shielded (1.8m).

3.5 CONFIGURATION OF SYSTEM UNDER TEST

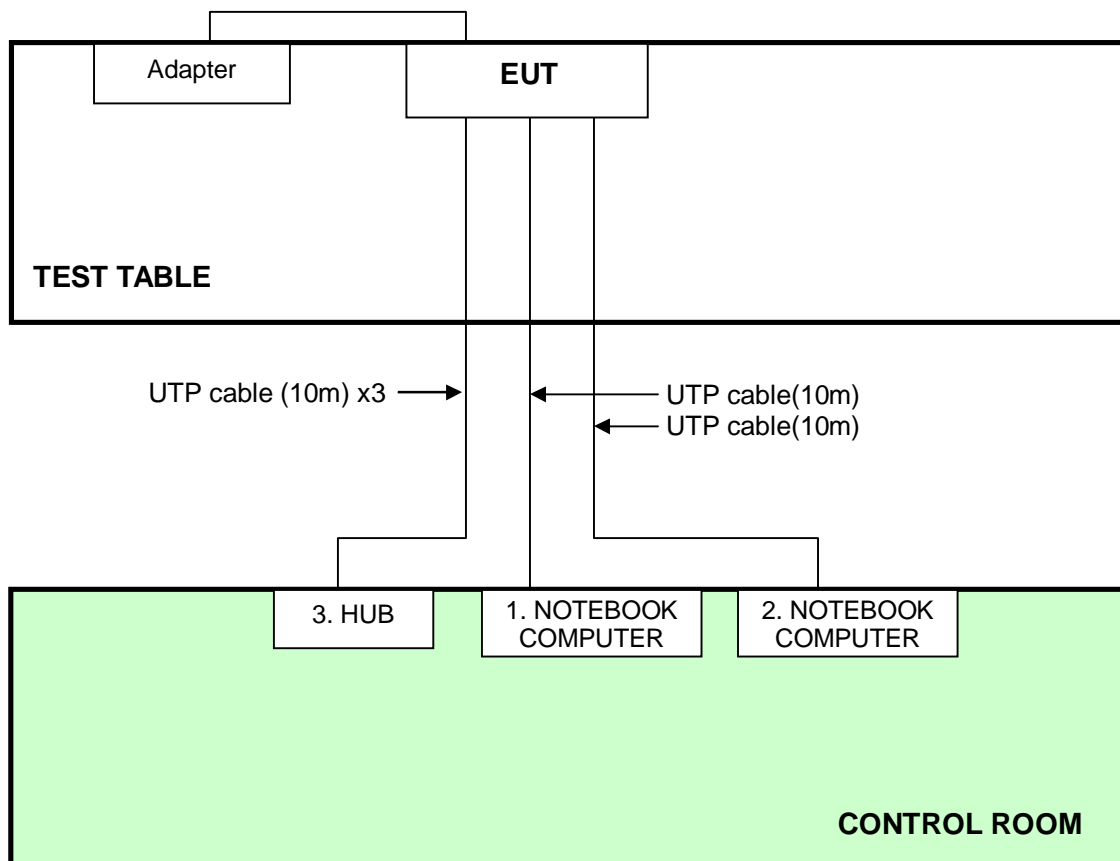

4. TEST TYPES AND RESULTS

4.1 CONDUCTED EMISSION MEASUREMENT

4.1.1 LIMITS OF CONDUCTED EMISSION MEASUREMENT

FREQUENCY OF EMISSION (MHz)	CONDUCTED LIMIT (dB μ V)	
	Quasi-peak	Average
0.15-0.5	66 to 56	56 to 46
0.5-5	56	46
5-30	60	50

- NOTE:**
1. The lower limit shall apply at the transition frequencies.
 2. The limit decreases in line with the logarithm of the frequency in the range of 0.15 to 0.50 MHz.

4.1.2 TEST INSTRUMENTS

Test date: Dec. 12, 2011

DESCRIPTION & MANUFACTURER	MODEL NO.	SERIAL NO.	CALIBRATED DATE	CALIBRATED UNTIL
ROHDE & SCHWARZ Test Receiver	ESCS 30	100287	Mar. 02, 2011	Mar. 01, 2012
Line-Impedance Stabilization Network (for EUT)	NSLK 8127	8127-523	Sep. 20, 2011	Sep. 19, 2012
Line-Impedance Stabilization Network (for Peripheral)	ENV-216	100072	June 10, 2011	June 09, 2012
RF Cable (JYEBAO)	5DFB	CONCAB-003	Aug. 05, 2011	Aug. 04, 2012
50 ohms Terminator	50	3	Nov. 02, 2011	Nov. 01, 2012
Software	BV ADT_Cond_V7.3.7	NA	NA	NA

Note:

1. The calibration interval of the above test instruments is 12 months and the calibrations are traceable to NML/ROC and NIST/USA.
2. The test was performed in Shielded Room No. A.
3. The VCCI Con A Registration No. is C-817.

4.1.3 TEST PROCEDURES

- a. The EUT was placed 0.4 meters from the conducting wall of the shielded room with EUT being connected to the power mains through a line impedance stabilization network (LISN). Other support units were connected to the power mains through another LISN. The two LISNs provide 50 ohm/ 50uH of coupling impedance for the measuring instrument.
- b. Both lines of the power mains connected to the EUT were checked for maximum conducted interference.
- c. The frequency range from 150kHz to 30MHz was searched. Emission levels under (Limit - 20dB) were not recorded.

4.1.4 DEVIATION FROM TEST STANDARD

No deviation

4.1.5 TEST SETUP

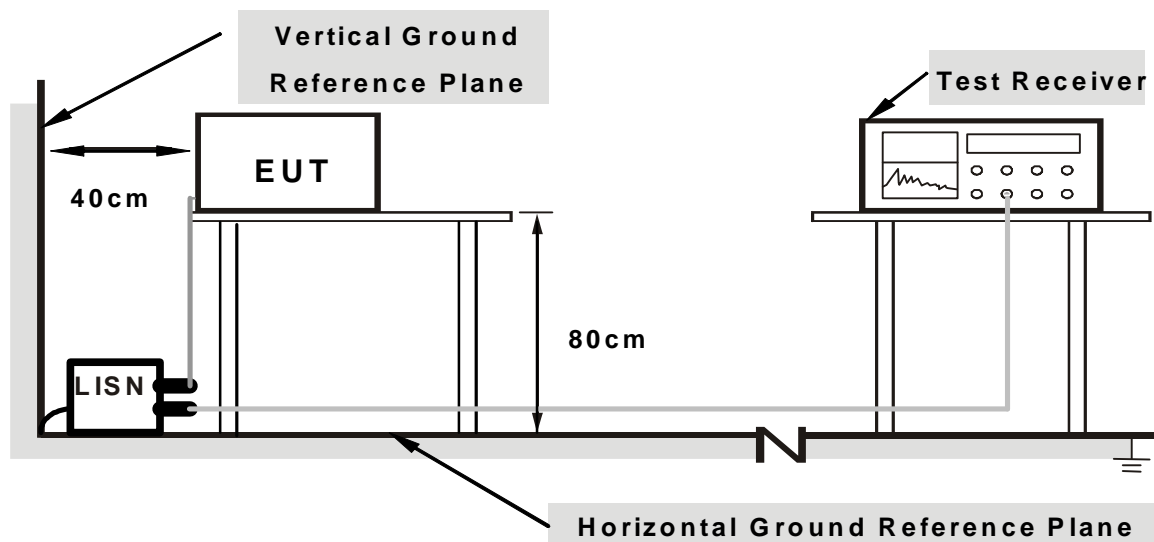

Note: 1. Support units were connected to second LISN.

2. Both of LISNs (AMN) are 80 cm from EUT and at least 80 from other units and other metal planes

For the actual test configuration, please refer to the related item – Photographs of the Test Configuration.

4.1.6 EUT OPERATING CONDITIONS

1. Placed the EUT on testing table.
2. Prepared computer systems (support unit 1~2) to act as communication partner and placed it outside of testing area.
3. The communication partner ran test program “MP_TEST.exe” to enable EUT under transmission/receiving condition continuously at specific channel frequency.

4.1.7 TEST RESULTS (MODE 1)

PHASE	Line (L)	6dB BANDWIDTH	9 kHz
-------	----------	---------------	-------

No	Freq. [MHz]	Corr. Factor (dB)	Reading Value [dB (uV)]		Emission Level [dB (uV)]		Limit [dB (uV)]		Margin (dB)	
			Q.P.	AV.	Q.P.	AV.	Q.P.	AV.	Q.P.	AV.
			1	0.166	0.06	39.45	31.19	39.51	31.25	65.18
2	0.201	0.06	37.19	28.48	37.25	28.54	63.56	53.56	-26.31	-25.02
3	0.370	0.08	31.30	25.21	31.38	25.29	58.50	48.50	-27.12	-23.21
4	12.809	0.71	35.38	29.93	36.09	30.64	60.00	50.00	-23.91	-19.36
5	16.228	0.87	41.32	36.69	42.19	37.56	60.00	50.00	-17.81	-12.44
6	21.664	1.05	46.81	40.20	47.86	41.25	60.00	50.00	-12.14	-8.75

- REMARKS:**
1. Q.P. and AV. are abbreviations of quasi-peak and average individually.
 2. The emission levels of other frequencies were very low against the limit.
 3. Margin value = Emission level - Limit value
 4. Correction factor = Insertion loss + Cable loss
 5. Emission Level = Correction Factor + Reading Value.

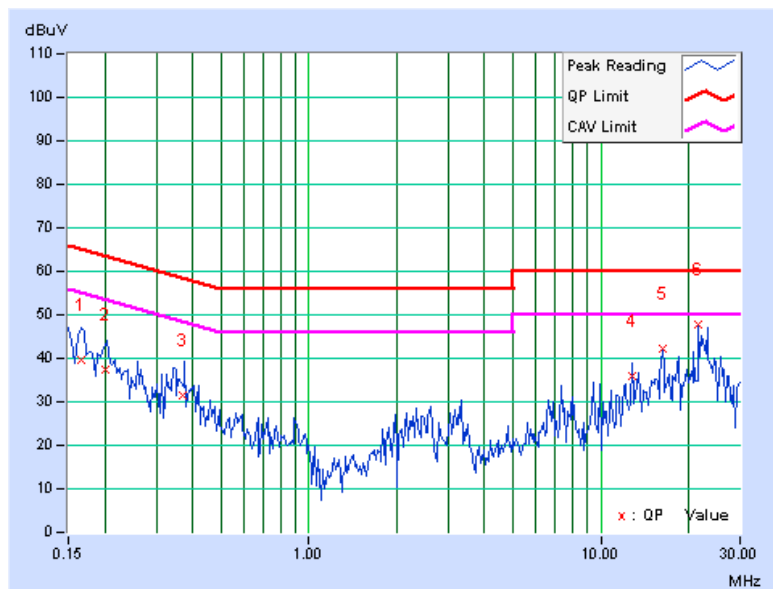

PHASE	Neutral (N)	6dB BANDWIDTH	9 kHz
--------------	-------------	----------------------	-------

No	Freq. [MHz]	Corr. Factor (dB)	Reading Value		Emission Level		Limit		Margin	
			[dB (uV)]		[dB (uV)]		[dB (uV)]		(dB)	
			Q.P.	AV.	Q.P.	AV.	Q.P.	AV.	Q.P.	AV.
1	0.169	0.07	44.24	32.65	44.31	32.72	65.03	55.03	-20.72	-22.31
2	0.237	0.08	39.24	28.95	39.32	29.03	62.22	52.22	-22.90	-23.19
3	0.362	0.09	31.80	26.67	31.89	26.76	58.67	48.67	-26.78	-21.91
4	2.551	0.23	23.93	13.39	24.16	13.62	56.00	46.00	-31.84	-32.38
5	16.227	0.86	40.68	34.57	41.54	35.43	60.00	50.00	-18.46	-14.57
6	23.129	1.09	41.37	37.08	42.46	38.17	60.00	50.00	-17.54	-11.83

- REMARKS:**
1. Q.P. and AV. are abbreviations of quasi-peak and average individually.
 2. The emission levels of other frequencies were very low against the limit.
 3. Margin value = Emission level - Limit value
 4. Correction factor = Insertion loss + Cable loss
 5. Emission Level = Correction Factor + Reading Value.

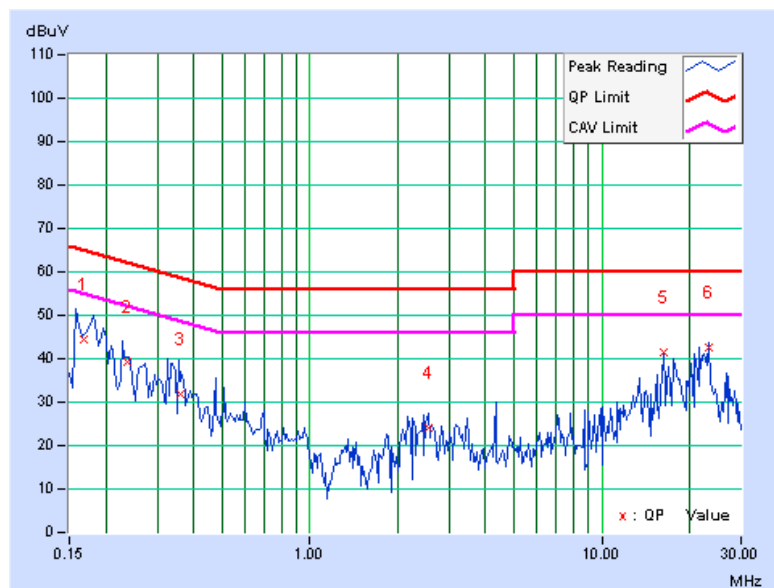

4.1.8 TEST RESULTS (MODE 2)

PHASE	Line (L)	6dB BANDWIDTH	9 kHz
--------------	----------	----------------------	-------

No	Freq.	Corr.	Reading Value		Emission Level		Limit		Margin	
	[MHz]	Factor	[dB (uV)]		[dB (uV)]		[dB (uV)]		(dB)	
		(dB)	Q.P.	AV.	Q.P.	AV.	Q.P.	AV.	Q.P.	AV.
1	0.161	0.06	47.93	37.27	47.99	37.33	65.39	55.39	-17.40	-18.06
2	0.213	0.06	42.24	33.29	42.30	33.35	63.07	53.07	-20.77	-19.72
3	0.505	0.08	42.12	30.73	42.20	30.81	56.00	46.00	-13.80	-15.19
4	1.133	0.11	28.88	18.18	28.99	18.29	56.00	46.00	-27.01	-27.71
5	12.199	0.69	33.48	27.33	34.17	28.02	60.00	50.00	-25.83	-21.98
6	23.129	1.09	48.27	42.35	49.36	43.44	60.00	50.00	-10.64	-6.56

- REMARKS:**
1. Q.P. and AV. are abbreviations of quasi-peak and average individually.
 2. The emission levels of other frequencies were very low against the limit.
 3. Margin value = Emission level - Limit value
 4. Correction factor = Insertion loss + Cable loss
 5. Emission Level = Correction Factor + Reading Value.

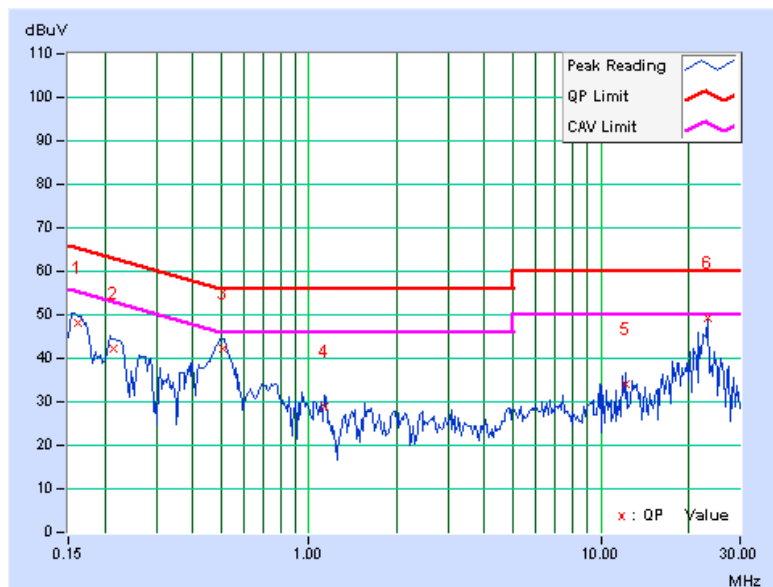

PHASE	Neutral (N)	6dB BANDWIDTH	9 kHz
--------------	-------------	----------------------	-------

No	Freq.	Corr.	Reading Value		Emission Level		Limit		Margin	
	[MHz]	Factor	[dB (uV)]		[dB (uV)]		[dB (uV)]		(dB)	
		(dB)	Q.P.	AV.	Q.P.	AV.	Q.P.	AV.	Q.P.	AV.
1	0.158	0.07	47.19	31.35	47.26	31.42	65.58	55.58	-18.32	-24.16
2	0.214	0.08	41.14	30.26	41.22	30.34	63.03	53.03	-21.81	-22.69
3	0.509	0.09	38.75	26.44	38.84	26.53	56.00	46.00	-17.16	-19.47
4	1.121	0.12	24.41	14.39	24.53	14.51	56.00	46.00	-31.47	-31.49
5	18.488	0.95	36.58	29.87	37.53	30.82	60.00	50.00	-22.47	-19.18
6	23.129	1.09	45.87	40.95	46.96	42.04	60.00	50.00	-13.04	-7.96

- REMARKS:**
1. Q.P. and AV. are abbreviations of quasi-peak and average individually.
 2. The emission levels of other frequencies were very low against the limit.
 3. Margin value = Emission level - Limit value
 4. Correction factor = Insertion loss + Cable loss
 5. Emission Level = Correction Factor + Reading Value.

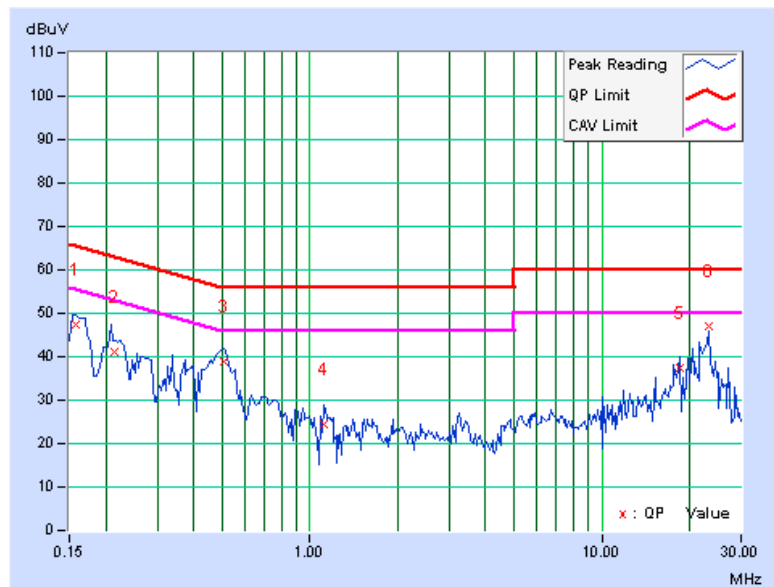

4.2 RADIATED EMISSION MEASUREMENT

4.2.1 LIMITS OF RADIATED EMISSION MEASUREMENT

Emissions radiated outside of the specified bands, shall be according to the general radiated limits in 15.209 as following:

Frequencies (MHz)	Field strength (microvolts/meter)	Measurement distance (meters)
0.009-0.490	2400/F(kHz)	300
0.490-1.705	24000/F(kHz)	30
1.705-30.0	30	30
30-88	100	3
88-216	150	3
216-960	200	3
Above 960	500	3

NOTE:

1. The lower limit shall apply at the transition frequencies.
2. Emission level (dBuV/m) = 20 log Emission level (uV/m).
3. As shown in 15.35(b), for frequencies above 1000MHz, the field strength limits are based on average detector, however, the peak field strength of any emission shall not exceed the maximum permitted average limits, specified above by more than 20dB under any condition of modulation.
4. Section 15.205 restricted bands of operation shall compliance with the limits in Section 15.209.



A D T

4.2.2 TEST INSTRUMENTS

Test date: Dec. 02 to 03, 2011

DESCRIPTION & MANUFACTURER	MODEL NO.	SERIAL NO.	CALIBRATED DATE	CALIBRATED UNTIL
Agilent Spectrum Analyzer	E4446A	MY48250254	July 12, 2011	July 11, 2012
Agilent Pre-Selector	N9039A	MY46520311	July 12, 2011	July 11, 2012
Agilent Signal Generator	N5181A	MY49060517	July 12, 2011	July 11, 2012
Mini-Circuits Pre-Amplifier	ZFL-1000VH2B	AMP-ZFL-03	Nov. 15, 2011	Nov. 14, 2012
Agilent Pre-Amplifier	8449B	3008A02578	July 04, 2011	July 03, 2012
SPACEK LABS	SLKKa-48-6	9K16	Nov. 15, 2011	Nov. 14, 2012
SCHWARZBECK Trilog Broadband Antenna	VULB 9168	9168-360	Apr. 14, 2011	Apr. 13, 2012
AISI Horn_Antenna	AIH.8018	0000320091110	Nov. 14, 2011	Nov. 13, 2012
SCHWARZBECK Horn_Antenna	BBHA 9170	9170-424	Oct. 07, 2011	Oct. 06, 2012
RF CABLE	NA	RF104-201 RF104-203 RF104-204	Dec. 27, 2010	Dec. 26, 2011
RF Cable	NA	CHGCAB_001	Oct. 07, 2011	Oct. 06, 2012
Software	ADT_Radiated_V8.7.05	NA	NA	NA
CT Antenna Tower & Turn Table	NA	NA	NA	NA

- Note: 1. The calibration interval of the above test instruments is 12 months and the calibrations are traceable to NML/ROC and NIST/USA.
2. The horn antenna, preamplifier (model: 8449B) are used only for the measurement of emission frequency above 1GHz if tested.
3. The test was performed in 966 Chamber No. G.
4. The FCC Site Registration No. is 966073.
5. The VCCI Site Registration No. is G-137.
6. The CANADA Site Registration No. is IC 7450H-2.

4.2.3 TEST PROCEDURES

- a. The EUT was placed on the top of a rotating table 0.8 meters above the ground at 3 meter chamber room. The table was rotated 360 degrees to determine the position of the highest radiation.
- b. The EUT was set 3 meters away from the interference-receiving antenna, which was mounted on the top of a variable-height antenna tower.
- c. The height of antenna is varied from one meter to four meters above the ground to determine the maximum value of the field strength. Both horizontal and vertical polarizations of the antenna are set to make the measurement.
- d. For each suspected emission, the EUT was arranged to its worst case and then the antenna was tuned to heights from 1 meter to 4 meters and the rotatable table was turned from 0 degrees to 360 degrees to find the maximum reading.
- e. The test-receiver system was set to quasi-peak detect function and specified bandwidth with maximum hold mode when the test frequency is below 1 GHz.
- f. The test-receiver system was set to peak and average detect function and specified bandwidth with maximum hold mode when the test frequency is above 1 GHz. If the peak reading value also meets average limit, measurement with the average detector is unnecessary.

NOTE:

1. The resolution bandwidth and video bandwidth of test receiver/spectrum analyzer is 120kHz for Quasi-peak detection (QP) at frequency below 1GHz.
2. The resolution bandwidth of test receiver/spectrum analyzer is 1 MHz and the video bandwidth is 3 MHz for Peak detection (PK) at frequency above 1GHz.
3. The resolution bandwidth of test receiver/spectrum analyzer is 1 MHz and the video bandwidth is 10 Hz for Average detection (AV) at frequency above 1GHz.

4.2.4 DEVIATION FROM TEST STANDARD

No deviation

4.2.5 TEST SETUP

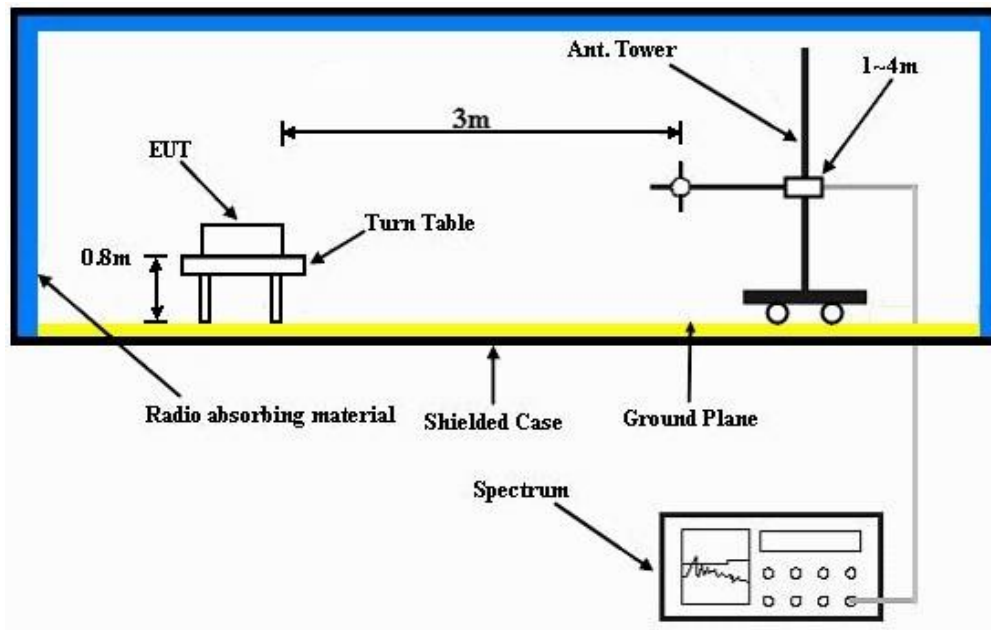

For the actual test configuration, please refer to the related item – Photographs of the Test Configuration.

4.2.6 EUT OPERATING CONDITIONS

Same as 4.1.6



A D T

4.2.7 TEST RESULTS

BELOW 1GHz WORST-CASE DATA : 802.11n (20MHz) OFDM MODULATION

EUT TEST CONDITION		MEASUREMENT DETAIL	
CHANNEL	Channel 6	FREQUENCY RANGE	Below 1000MHz
INPUT POWER	120Vac, 60Hz	DETECTOR FUNCTION	Quasi-Peak
ENVIRONMENTAL CONDITIONS	17deg. C, 63%RH	TESTED BY	Kent Liu

ANTENNA POLARITY & TEST DISTANCE: HORIZONTAL AT 3 M								
NO.	FREQ. (MHz)	EMISSION LEVEL (dBuV/m)	LIMIT (dBuV/m)	MARGIN (dB)	ANTENNA HEIGHT (m)	TABLE ANGLE (Degree)	RAW VALUE (dBuV)	CORRECTION FACTOR (dB/m)
1	98.45	38.0 QP	43.5	-5.5	1.75 H	121	28.70	9.33
2	159.67	35.8 QP	43.5	-7.7	1.75 H	284	21.17	14.63
3	312.44	41.6 QP	46.0	-4.4	1.00 H	54	25.93	15.65
4	435.83	37.0 QP	46.0	-9.0	2.00 H	300	18.24	18.79
5	500.02	36.3 QP	46.0	-9.7	2.00 H	283	16.00	20.31
6	799.98	30.6 QP	46.0	-15.4	1.00 H	49	4.76	25.87
ANTENNA POLARITY & TEST DISTANCE: VERTICAL AT 3 M								
NO.	FREQ. (MHz)	EMISSION LEVEL (dBuV/m)	LIMIT (dBuV/m)	MARGIN (dB)	ANTENNA HEIGHT (m)	TABLE ANGLE (Degree)	RAW VALUE (dBuV)	CORRECTION FACTOR (dB/m)
1	66.24	35.3 QP	40.0	-4.7	1.25 V	97	22.38	12.96
2	106.15	35.9 QP	43.5	-7.6	1.25 V	46	25.44	10.43
3	312.44	36.6 QP	46.0	-9.4	1.50 V	33	20.94	15.65
4	439.15	37.4 QP	46.0	-8.6	1.25 V	227	18.57	18.87
5	500.02	38.1 QP	46.0	-8.0	1.00 V	159	17.74	20.31
6	799.98	34.3 QP	46.0	-11.8	1.25 V	360	8.38	25.87

- REMARKS:**
1. Emission level (dBuV/m) = Raw Value (dBuV) + Correction Factor (dB/m).
 2. Correction Factor (dB/m) = Antenna Factor (dB/m) + Cable Factor (dB).
 3. The other emission levels were very low against the limit.
 4. Margin value = Emission level – Limit value.



A D T

ABOVE 1GHz WORST-CASE DATA

802.11b DSSS MODULATION

EUT TEST CONDITION		MEASUREMENT DETAIL	
CHANNEL	Channel 1	FREQUENCY RANGE	1 ~ 25GHz
INPUT POWER	120Vac, 60Hz	DETECTOR FUNCTION	Peak (PK) Average (AV)
ENVIRONMENTAL CONDITIONS	15deg. C, 61%RH	TESTED BY	Evan Huang

ANTENNA POLARITY & TEST DISTANCE: HORIZONTAL AT 3 M								
NO.	FREQ. (MHz)	EMISSION LEVEL (dBuV/m)	LIMIT (dBuV/m)	MARGIN (dB)	ANTENNA HEIGHT (m)	TABLE ANGLE (Degree)	RAW VALUE (dBuV)	CORRECTION FACTOR (dB/m)
1	2385.20	57.4 PK	74.0	-16.6	1.00 H	262	25.67	31.73
2	2385.20	47.6 AV	54.0	-6.4	1.00 H	262	15.87	31.73
3	*2412.00	102.3 PK			1.00 H	262	70.48	31.82
4	*2412.00	100.2 AV			1.00 H	262	68.38	31.82
5	4824.00	54.8 PK	74.0	-19.2	1.00 H	107	15.44	39.36
6	4824.00	51.4 AV	54.0	-2.6	1.00 H	107	12.04	39.36
ANTENNA POLARITY & TEST DISTANCE: VERTICAL AT 3 M								
NO.	FREQ. (MHz)	EMISSION LEVEL (dBuV/m)	LIMIT (dBuV/m)	MARGIN (dB)	ANTENNA HEIGHT (m)	TABLE ANGLE (Degree)	RAW VALUE (dBuV)	CORRECTION FACTOR (dB/m)
1	2385.30	61.1 PK	74.0	-12.9	1.16 V	23	29.37	31.73
2	2385.30	52.9 AV	54.0	-1.1	1.16 V	23	21.17	31.73
3	*2412.00	110.2 PK			1.14 V	22	78.38	31.82
4	*2412.00	108.3 AV			1.14 V	22	76.48	31.82
5	4824.00	54.9 PK	74.0	-19.1	1.07 V	107	15.54	39.36
6	4824.00	53.1 AV	54.0	-0.9	1.07 V	107	13.74	39.36

- REMARKS:**
1. Emission level (dBuV/m) = Raw Value (dBuV) + Correction Factor (dB/m).
 2. Correction Factor (dB/m) = Antenna Factor (dB/m) + Cable Factor (dB).
 3. The other emission levels were very low against the limit.
 4. Margin value = Emission level – Limit value.
 5. “ * “: Fundamental frequency.



A D T

EUT TEST CONDITION		MEASUREMENT DETAIL	
CHANNEL	Channel 6	FREQUENCY RANGE	1 ~ 25GHz
INPUT POWER	120Vac, 60Hz	DETECTOR FUNCTION	Peak (PK) Average (AV)
ENVIRONMENTAL CONDITIONS	15deg. C, 61%RH	TESTED BY	Evan Huang

ANTENNA POLARITY & TEST DISTANCE: HORIZONTAL AT 3 M								
NO.	FREQ. (MHz)	EMISSION LEVEL (dBuV/m)	LIMIT (dBuV/m)	MARGIN (dB)	ANTENNA HEIGHT (m)	TABLE ANGLE (Degree)	RAW VALUE (dBuV)	CORRECTION FACTOR (dB/m)
1	*2437.00	105.6 PK			1.00 H	258	73.68	31.92
2	*2437.00	103.4 AV			1.00 H	258	71.48	31.92
3	4874.00	55.5 PK	74.0	-18.5	1.00 H	106	16.03	39.50
4	4874.00	50.7 AV	54.0	-3.3	1.00 H	106	11.20	39.50
5	7311.00	54.3 PK	74.0	-19.7	1.00 H	71	7.42	46.88
6	7311.00	45.2 AV	54.0	-8.8	1.00 H	71	-1.68	46.88
ANTENNA POLARITY & TEST DISTANCE: VERTICAL AT 3 M								
NO.	FREQ. (MHz)	EMISSION LEVEL (dBuV/m)	LIMIT (dBuV/m)	MARGIN (dB)	ANTENNA HEIGHT (m)	TABLE ANGLE (Degree)	RAW VALUE (dBuV)	CORRECTION FACTOR (dB/m)
1	*2437.00	111.4 PK			1.14 V	22	79.48	31.92
2	*2437.00	109.4 AV			1.14 V	22	77.48	31.92
3	4874.00	54.3 PK	74.0	-19.7	1.19 V	108	14.80	39.50
4	4874.00	52.0 AV	54.0	-2.0	1.19 V	108	12.51	39.50
5	7311.00	56.8 PK	74.0	-17.2	1.51 V	304	9.94	46.88
6	7311.00	50.1 AV	54.0	-3.9	1.51 V	304	3.22	46.88

- REMARKS:**
1. Emission level (dBuV/m) = Raw Value (dBuV) + Correction Factor (dB/m).
 2. Correction Factor (dB/m) = Antenna Factor (dB/m) + Cable Factor (dB).
 3. The other emission levels were very low against the limit.
 4. Margin value = Emission level – Limit value.
 5. “ * “: Fundamental frequency.



A D T

EUT TEST CONDITION		MEASUREMENT DETAIL	
CHANNEL	Channel 11	FREQUENCY RANGE	1 ~ 25GHz
INPUT POWER	120Vac, 60Hz	DETECTOR FUNCTION	Peak (PK) Average (AV)
ENVIRONMENTAL CONDITIONS	15deg. C, 61%RH	TESTED BY	Evan Huang

ANTENNA POLARITY & TEST DISTANCE: HORIZONTAL AT 3 M								
NO.	FREQ. (MHz)	EMISSION LEVEL (dBuV/m)	LIMIT (dBuV/m)	MARGIN (dB)	ANTENNA HEIGHT (m)	TABLE ANGLE (Degree)	RAW VALUE (dBuV)	CORRECTION FACTOR (dB/m)
1	*2462.00	105.3 PK			1.00 H	256	73.29	32.01
2	*2462.00	103.1 AV			1.00 H	256	71.09	32.01
3	2487.60	57.9 PK	74.0	-16.1	1.00 H	8	25.80	32.10
4	2487.60	45.7 AV	54.0	-8.3	1.00 H	8	13.60	32.10
5	4924.00	53.9 PK	74.0	-20.1	1.00 H	106	14.23	39.67
6	4924.00	50.4 AV	54.0	-3.6	1.00 H	106	10.73	39.67
7	7386.00	55.4 PK	74.0	-18.6	1.08 H	66	8.60	46.80
8	7386.00	46.6 AV	54.0	-7.4	1.08 H	66	-0.20	46.80
ANTENNA POLARITY & TEST DISTANCE: VERTICAL AT 3 M								
NO.	FREQ. (MHz)	EMISSION LEVEL (dBuV/m)	LIMIT (dBuV/m)	MARGIN (dB)	ANTENNA HEIGHT (m)	TABLE ANGLE (Degree)	RAW VALUE (dBuV)	CORRECTION FACTOR (dB/m)
1	*2462.00	111.3 PK			1.12 V	21	79.29	32.01
2	*2462.00	109.3 AV			1.12 V	21	77.29	32.01
3	2487.70	61.4 PK	74.0	-12.6	1.14 V	21	29.30	32.10
4	2487.70	52.6 AV	54.0	-1.4	1.14 V	21	20.50	32.10
5	4924.00	55.5 PK	74.0	-18.5	1.03 V	108	15.83	39.67
6	4924.00	53.3 AV	54.0	-0.7	1.03 V	108	13.63	39.67
7	7386.00	57.3 PK	74.0	-16.7	1.55 V	270	10.50	46.80
8	7386.00	50.7 AV	54.0	-3.3	1.55 V	270	3.90	46.80

- REMARKS:**
1. Emission level (dBuV/m) = Raw Value (dBuV) + Correction Factor (dB/m).
 2. Correction Factor (dB/m) = Antenna Factor (dB/m) + Cable Factor (dB).
 3. The other emission levels were very low against the limit.
 4. Margin value = Emission level – Limit value.
 5. “ * “: Fundamental frequency.

RESTRICTED BANDEDGE (802.11b MODE, CH1, HORIZONTAL)

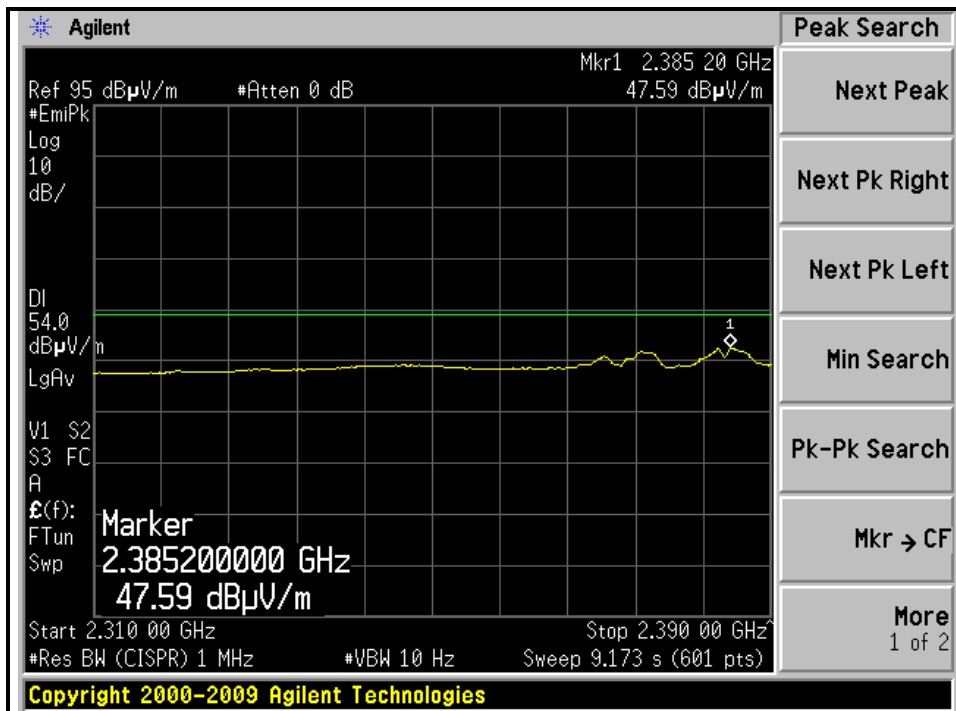
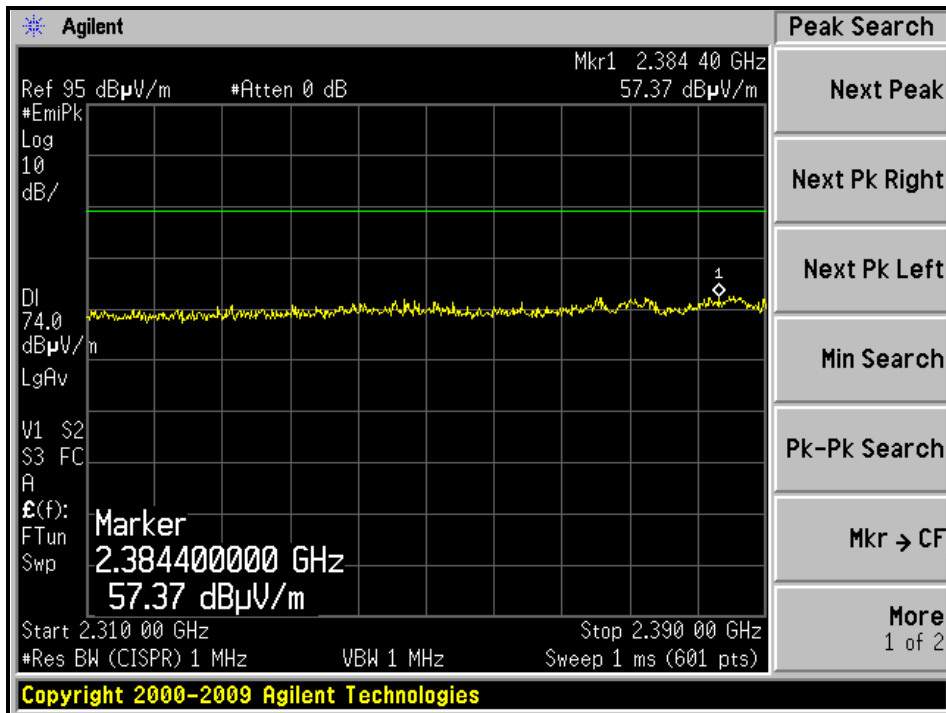



A D T

RESTRICTED BANDEDGE (802.11b MODE, CH1, VERTICAL)

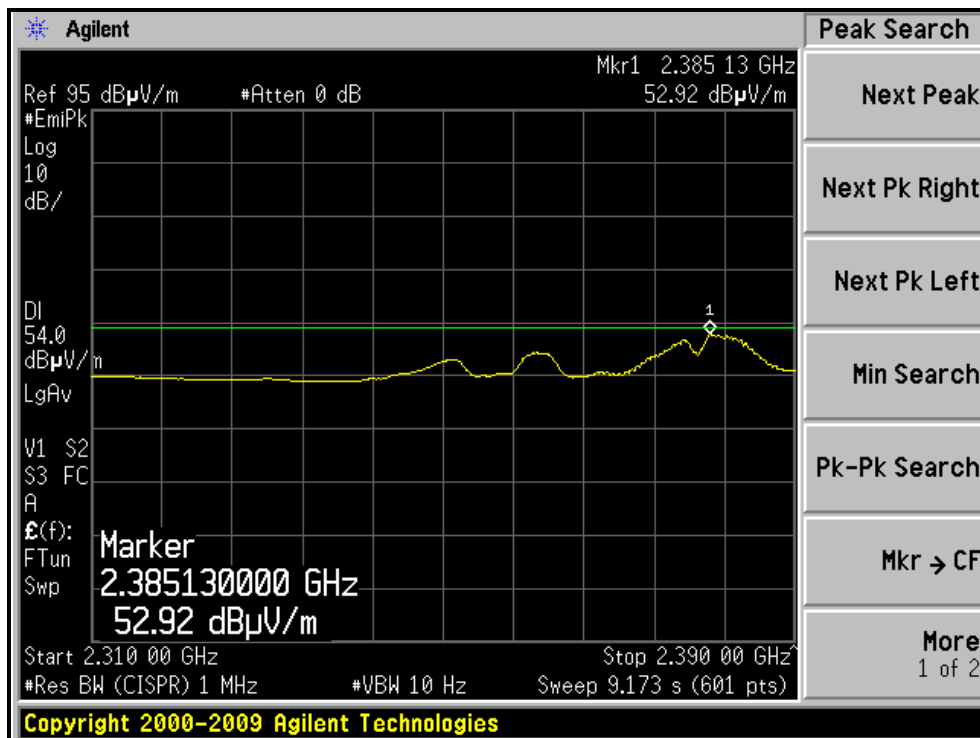
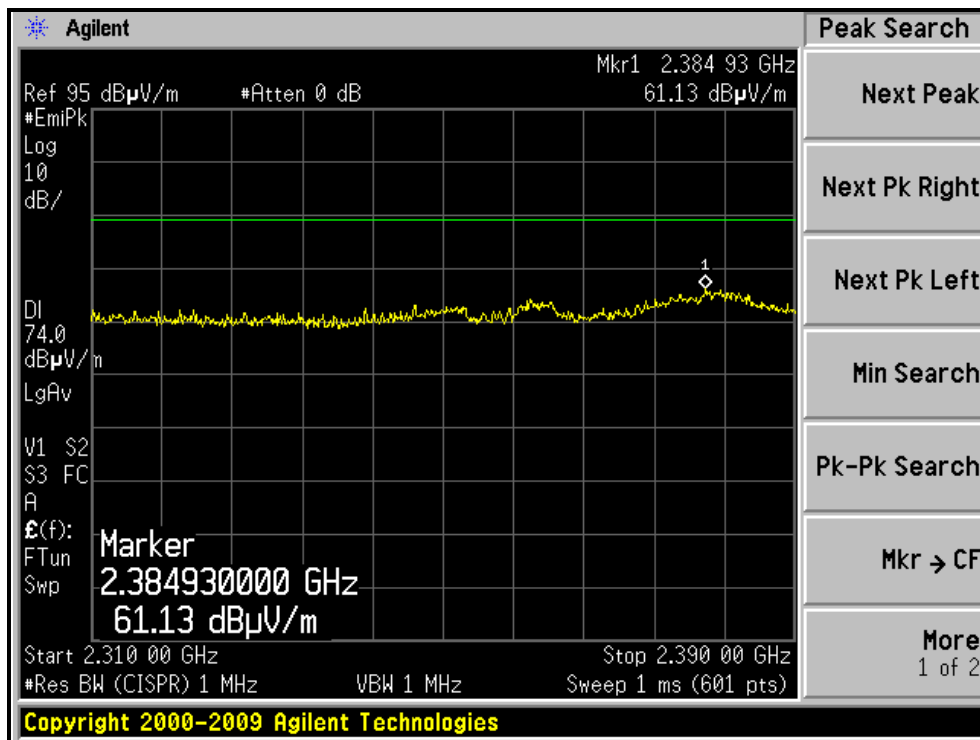

RESTRICTED BANDEDGE (802.11b MODE, CH11, HORIZONTAL)

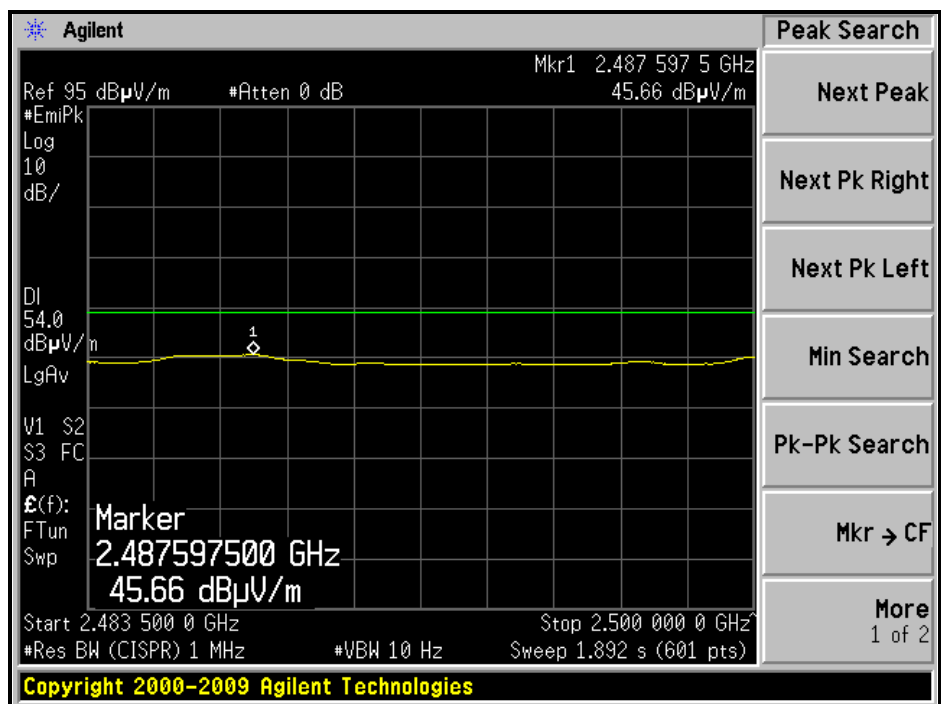
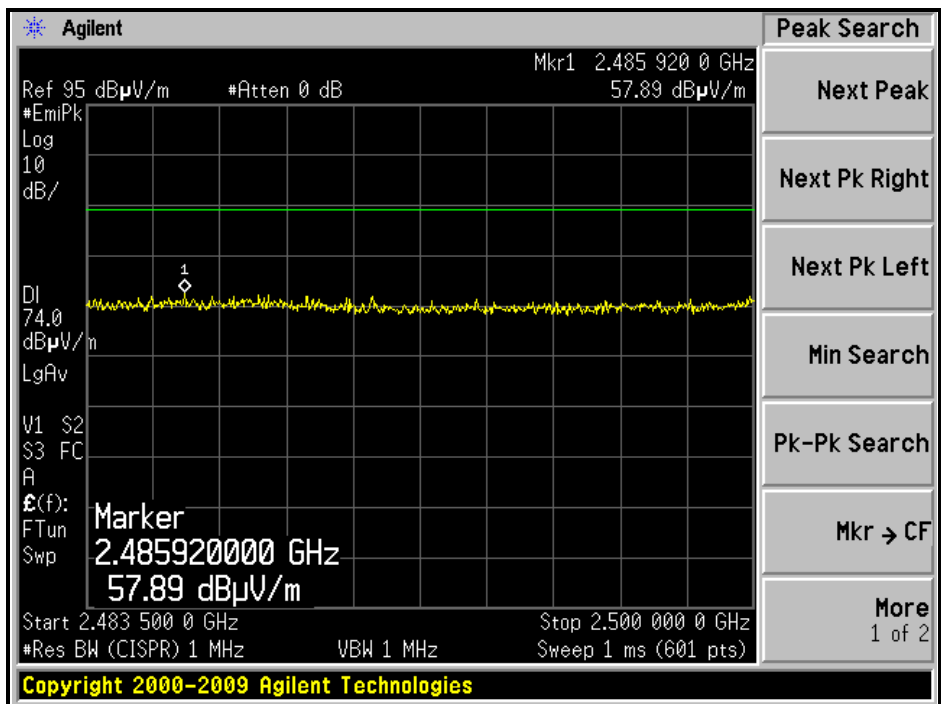



A D T

RESTRICTED BANDEDGE (802.11b MODE, CH11, VERTICAL)

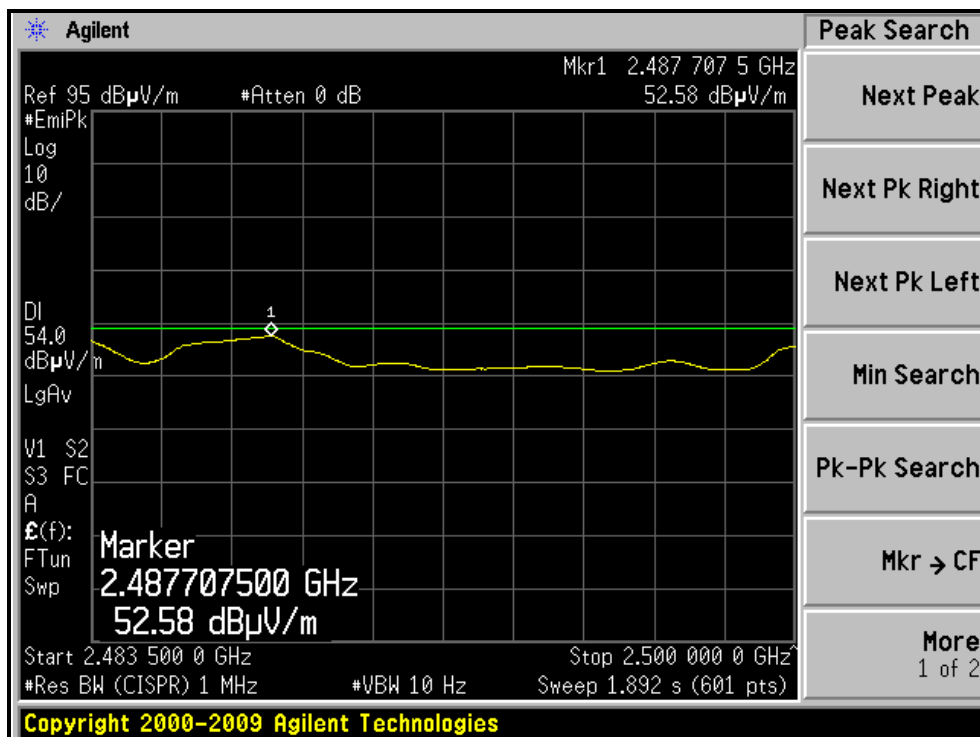
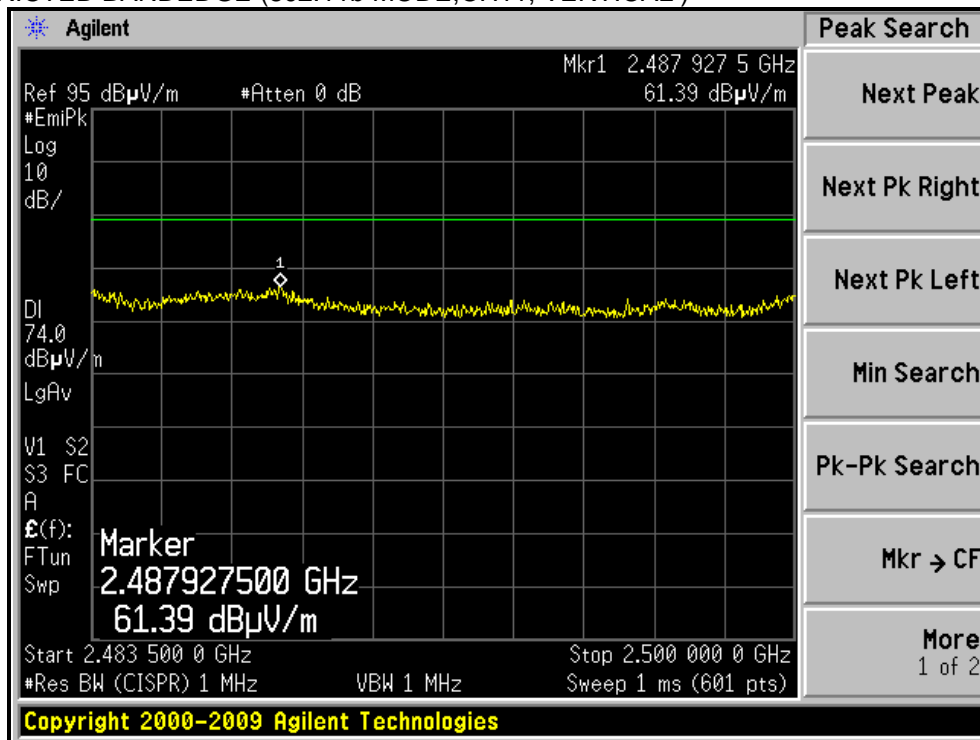



A D T

802.11g OFDM MODULATION

EUT TEST CONDITION		MEASUREMENT DETAIL	
CHANNEL	Channel 1	FREQUENCY RANGE	1 ~ 25GHz
INPUT POWER	120Vac, 60Hz	DETECTOR FUNCTION	Peak (PK) Average (AV)
ENVIRONMENTAL CONDITIONS	15deg. C, 61%RH	TESTED BY	Evan Huang

ANTENNA POLARITY & TEST DISTANCE: HORIZONTAL AT 3 M

NO.	FREQ. (MHz)	EMISSION LEVEL (dBuV/m)	LIMIT (dBuV/m)	MARGIN (dB)	ANTENNA HEIGHT (m)	TABLE ANGLE (Degree)	RAW VALUE (dBuV)	CORRECTION FACTOR (dB/m)
1	2390.00	63.1 PK	74.0	-10.9	1.00 H	262	31.35	31.75
2	2390.00	49.8 AV	54.0	-4.2	1.00 H	262	18.05	31.75
3	*2412.00	105.2 PK			1.00 H	262	73.38	31.82
4	*2412.00	95.4 AV			1.00 H	262	63.58	31.82
5	4824.00	46.6 PK	74.0	-27.4	1.00 H	315	7.24	39.36
6	4824.00	34.8 AV	54.0	-19.2	1.00 H	315	-4.56	39.36

ANTENNA POLARITY & TEST DISTANCE: VERTICAL AT 3 M

NO.	FREQ. (MHz)	EMISSION LEVEL (dBuV/m)	LIMIT (dBuV/m)	MARGIN (dB)	ANTENNA HEIGHT (m)	TABLE ANGLE (Degree)	RAW VALUE (dBuV)	CORRECTION FACTOR (dB/m)
1	2390.00	66.0 PK	74.0	-8.0	1.72 V	29	34.25	31.75
2	2390.00	53.5 AV	54.0	-0.5	1.72 V	29	21.75	31.75
3	*2412.00	111.1 PK			1.64 V	295	79.28	31.82
4	*2412.00	102.3 AV			1.64 V	295	70.48	31.82
5	4824.00	48.0 PK	74.0	-26.0	1.07 V	114	8.64	39.36
6	4824.00	37.3 AV	54.0	-16.7	1.07 V	114	-2.06	39.36

- REMARKS:**
1. Emission level (dBuV/m) = Raw Value (dBuV) + Correction Factor (dB/m).
 2. Correction Factor (dB/m) = Antenna Factor (dB/m) + Cable Factor (dB).
 3. The other emission levels were very low against the limit.
 4. Margin value = Emission level – Limit value.
 5. “ * “: Fundamental frequency.



A D T

EUT TEST CONDITION		MEASUREMENT DETAIL	
CHANNEL	Channel 6	FREQUENCY RANGE	1 ~ 25GHz
INPUT POWER	120Vac, 60Hz	DETECTOR FUNCTION	Peak (PK) Average (AV)
ENVIRONMENTAL CONDITIONS	15deg. C, 61%RH	TESTED BY	Evan Huang

ANTENNA POLARITY & TEST DISTANCE: HORIZONTAL AT 3 M								
NO.	FREQ. (MHz)	EMISSION LEVEL (dBuV/m)	LIMIT (dBuV/m)	MARGIN (dB)	ANTENNA HEIGHT (m)	TABLE ANGLE (Degree)	RAW VALUE (dBuV)	CORRECTION FACTOR (dB/m)
1	*2437.00	105.4 PK			1.00 H	261	73.48	31.92
2	*2437.00	96.8 AV			1.00 H	261	64.88	31.92
3	4874.00	47.1 PK	74.0	-26.9	1.00 H	313	7.60	39.50
4	4874.00	35.2 AV	54.0	-18.8	1.00 H	313	-4.30	39.50
5	7311.00	54.1 PK	74.0	-19.9	1.18 H	30	7.22	46.88
6	7311.00	43.3 AV	54.0	-10.7	1.18 H	30	-3.58	46.88
ANTENNA POLARITY & TEST DISTANCE: VERTICAL AT 3 M								
NO.	FREQ. (MHz)	EMISSION LEVEL (dBuV/m)	LIMIT (dBuV/m)	MARGIN (dB)	ANTENNA HEIGHT (m)	TABLE ANGLE (Degree)	RAW VALUE (dBuV)	CORRECTION FACTOR (dB/m)
1	*2437.00	112.5 PK			1.75 V	286	80.58	31.92
2	*2437.00	103.7 AV			1.75 V	286	71.78	31.92
3	4874.00	47.9 PK	74.0	-26.1	1.09 V	121	8.40	39.50
4	4874.00	37.1 AV	54.0	-16.9	1.09 V	121	-2.40	39.50
5	7311.00	54.1 PK	74.0	-19.9	1.38 V	223	7.22	46.88
6	7311.00	43.6 AV	54.0	-10.4	1.38 V	223	-3.28	46.88

- REMARKS:**
1. Emission level (dBuV/m) = Raw Value (dBuV) + Correction Factor (dB/m).
 2. Correction Factor (dB/m) = Antenna Factor (dB/m) + Cable Factor (dB).
 3. The other emission levels were very low against the limit.
 4. Margin value = Emission level – Limit value.
 5. “ * “: Fundamental frequency.



A D T

EUT TEST CONDITION		MEASUREMENT DETAIL	
CHANNEL	Channel 11	FREQUENCY RANGE	1 ~ 25GHz
INPUT POWER	120Vac, 60Hz	DETECTOR FUNCTION	Peak (PK) Average (AV)
ENVIRONMENTAL CONDITIONS	15deg. C, 61%RH	TESTED BY	Evan Huang

ANTENNA POLARITY & TEST DISTANCE: HORIZONTAL AT 3 M								
NO.	FREQ. (MHz)	EMISSION LEVEL (dBuV/m)	LIMIT (dBuV/m)	MARGIN (dB)	ANTENNA HEIGHT (m)	TABLE ANGLE (Degree)	RAW VALUE (dBuV)	CORRECTION FACTOR (dB/m)
1	*2462.00	105.6 PK			1.00 H	250	73.59	32.01
2	*2462.00	96.7 AV			1.00 H	250	64.69	32.01
3	2483.50	64.8 PK	74.0	-9.2	1.00 H	258	32.71	32.09
4	2483.50	50.2 AV	54.0	-3.8	1.00 H	258	18.11	32.09
5	4924.00	47.0 PK	74.0	-27.0	1.00 H	299	7.33	39.67
6	4924.00	35.2 AV	54.0	-18.8	1.00 H	299	-4.47	39.67
7	7386.00	54.5 PK	74.0	-19.5	1.23 H	16	7.70	46.80
8	7386.00	43.4 AV	54.0	-10.6	1.23 H	16	-3.40	46.80
ANTENNA POLARITY & TEST DISTANCE: VERTICAL AT 3 M								
NO.	FREQ. (MHz)	EMISSION LEVEL (dBuV/m)	LIMIT (dBuV/m)	MARGIN (dB)	ANTENNA HEIGHT (m)	TABLE ANGLE (Degree)	RAW VALUE (dBuV)	CORRECTION FACTOR (dB/m)
1	*2462.00	110.1 PK			1.57 V	58	78.10	32.01
2	*2462.00	101.3 AV			1.57 V	58	69.29	32.01
3	2483.50	63.9 PK	74.0	-10.1	1.89 V	61	31.81	32.09
4	2483.50	52.3 AV	54.0	-1.7	1.89 V	61	20.21	32.09
5	4924.00	48.3 PK	74.0	-25.7	1.05 V	112	8.63	39.67
6	4924.00	37.4 AV	54.0	-16.6	1.05 V	112	-2.27	39.67
7	7386.00	54.0 PK	74.0	-20.0	1.32 V	230	7.20	46.80
8	7386.00	43.8 AV	54.0	-10.2	1.32 V	230	-3.00	46.80

- REMARKS:**
1. Emission level (dBuV/m) = Raw Value (dBuV) + Correction Factor (dB/m).
 2. Correction Factor (dB/m) = Antenna Factor (dB/m) + Cable Factor (dB).
 3. The other emission levels were very low against the limit.
 4. Margin value = Emission level – Limit value.
 5. “ * “: Fundamental frequency.



A D T

RESTRICTED BANDEDGE (802.11g MODE, CH1, HORIZONTAL)

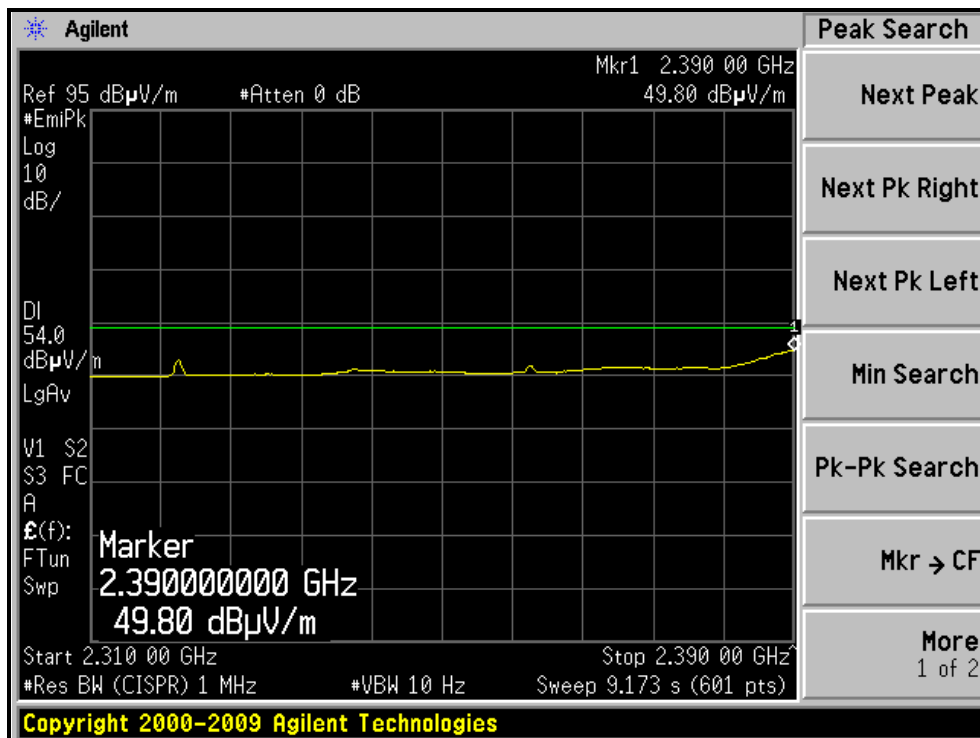
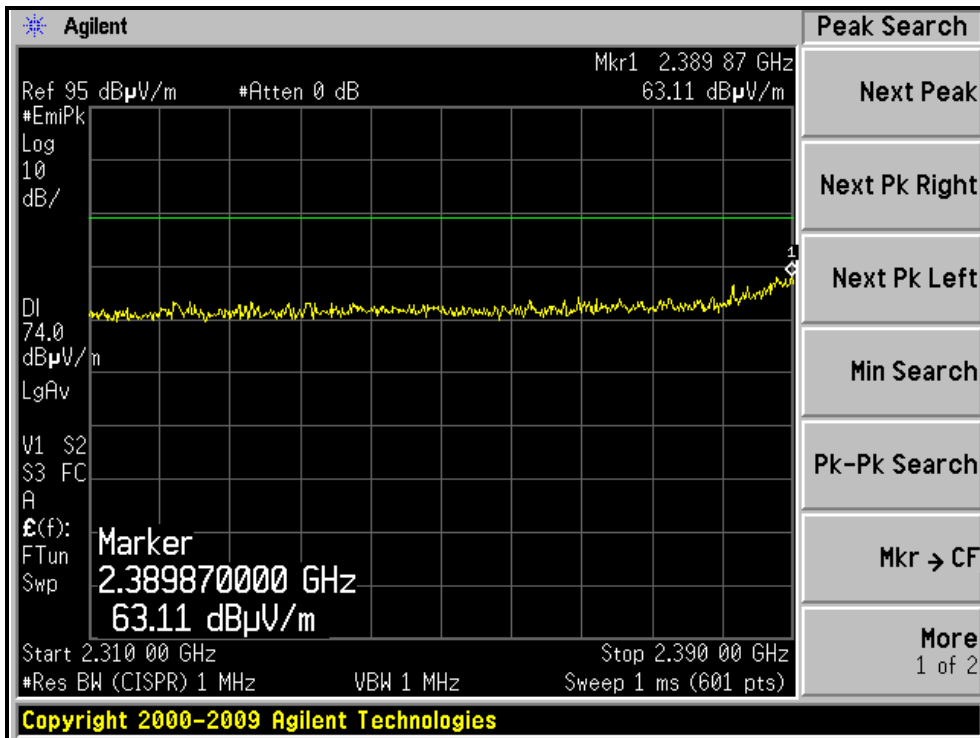



A D T

RESTRICTED BANDEDGE (802.11g MODE, CH1, VERTICAL)

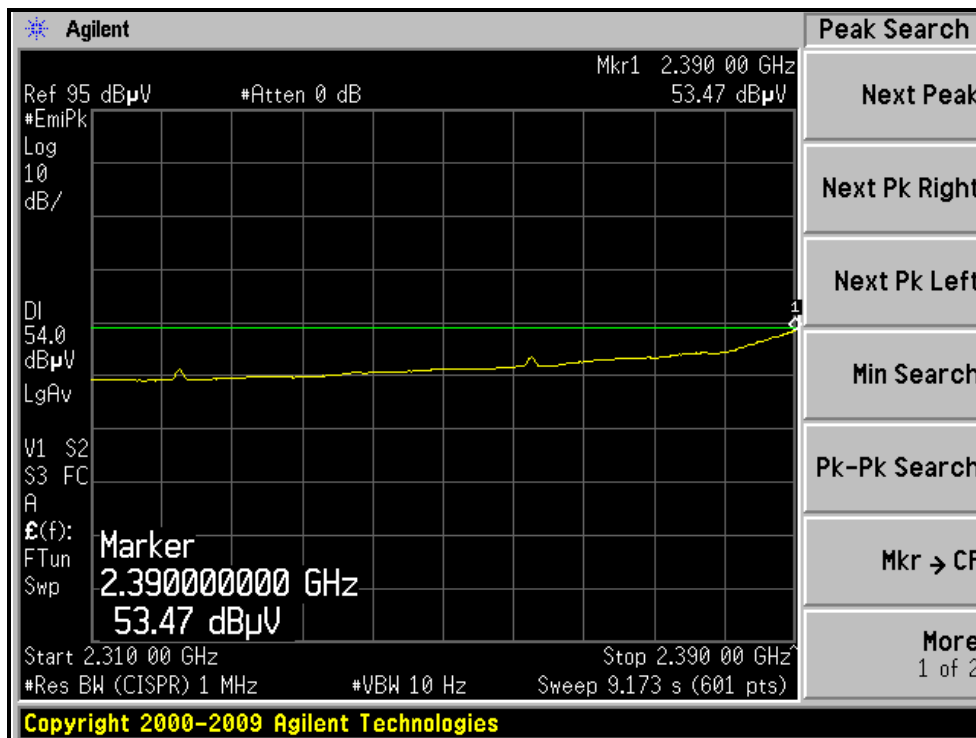
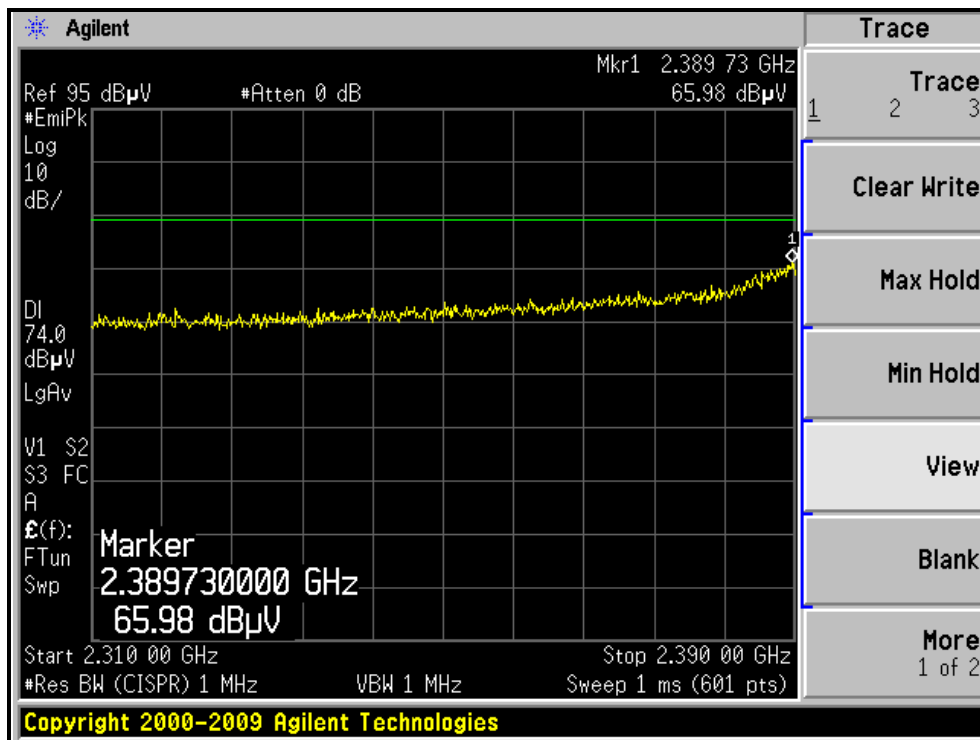

RESTRICTED BANDEDGE (802.11g MODE, CH11, HORIZONTAL)

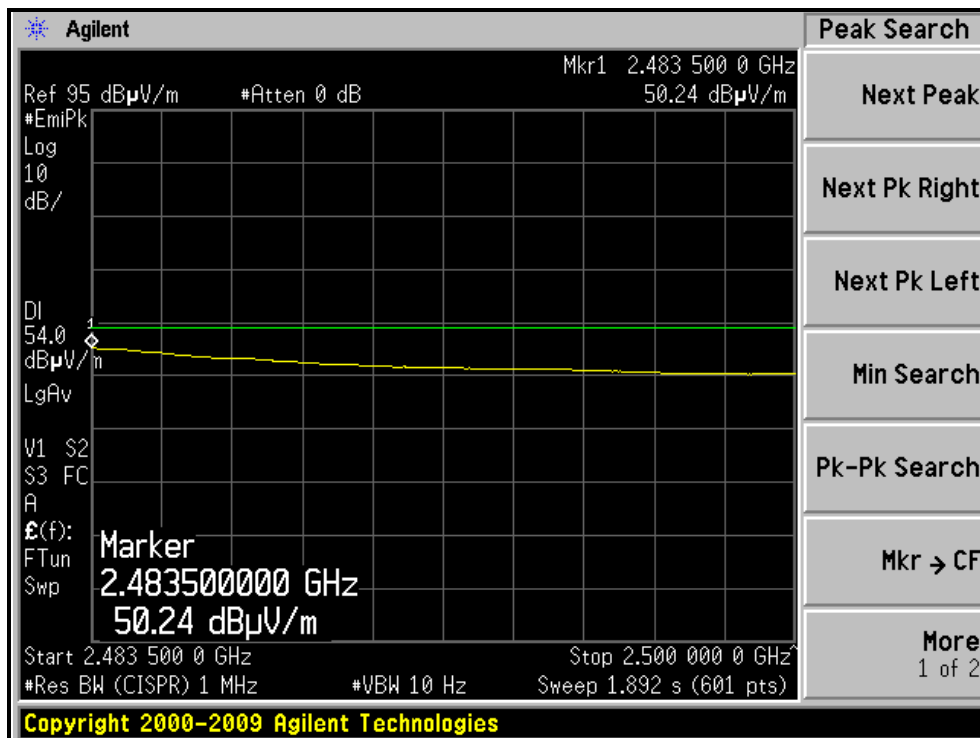
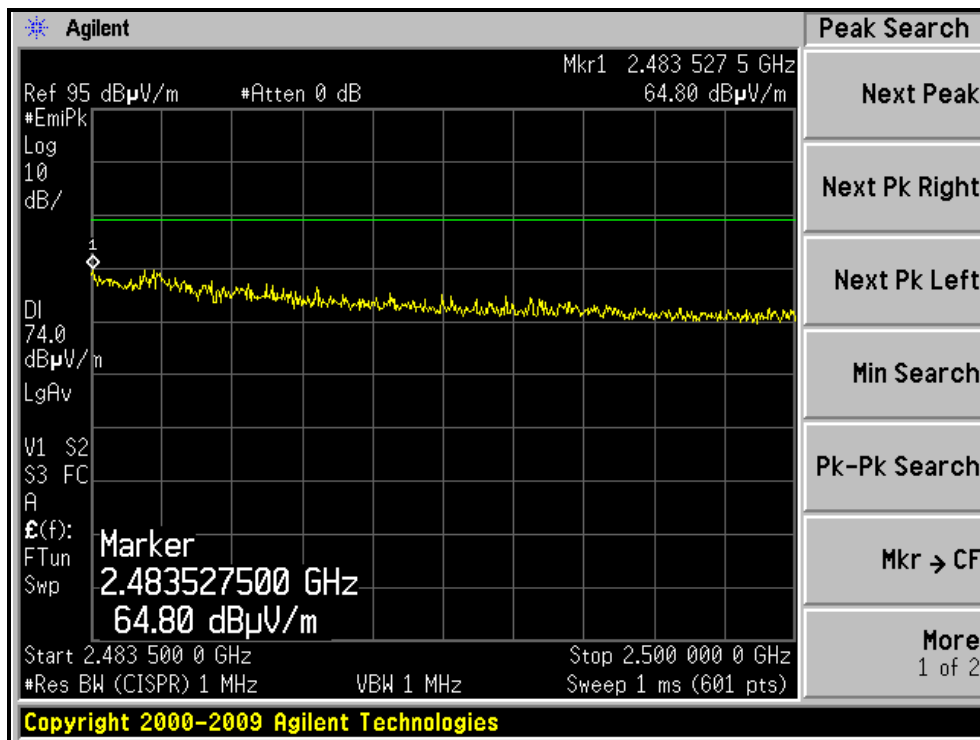

RESTRICTED BANDEDGE (802.11g MODE, CH11, VERTICAL)

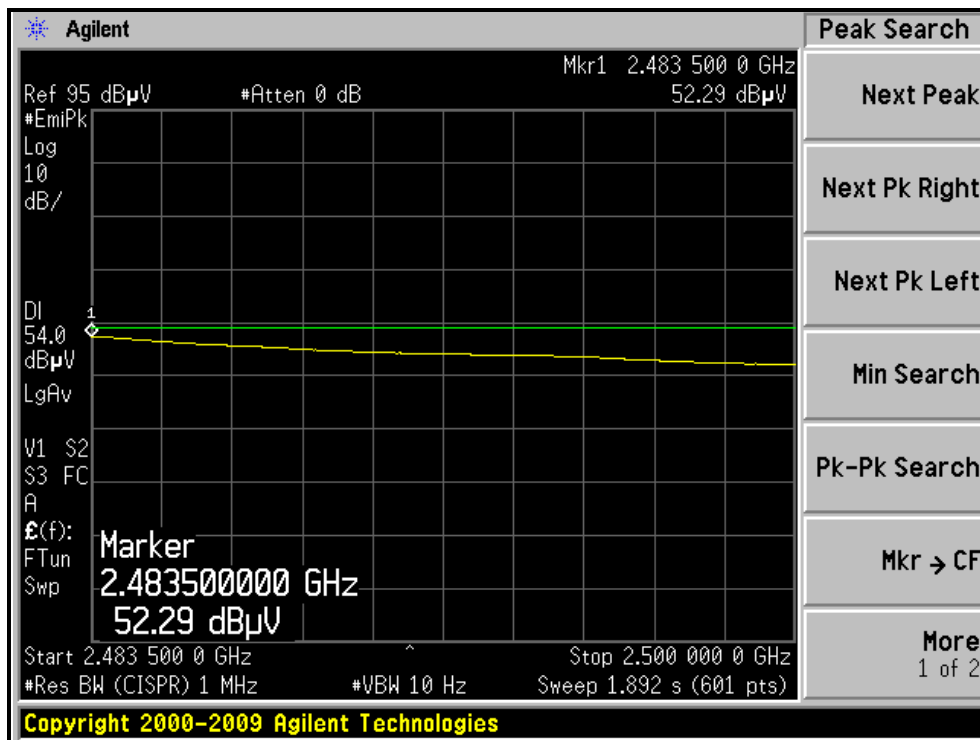
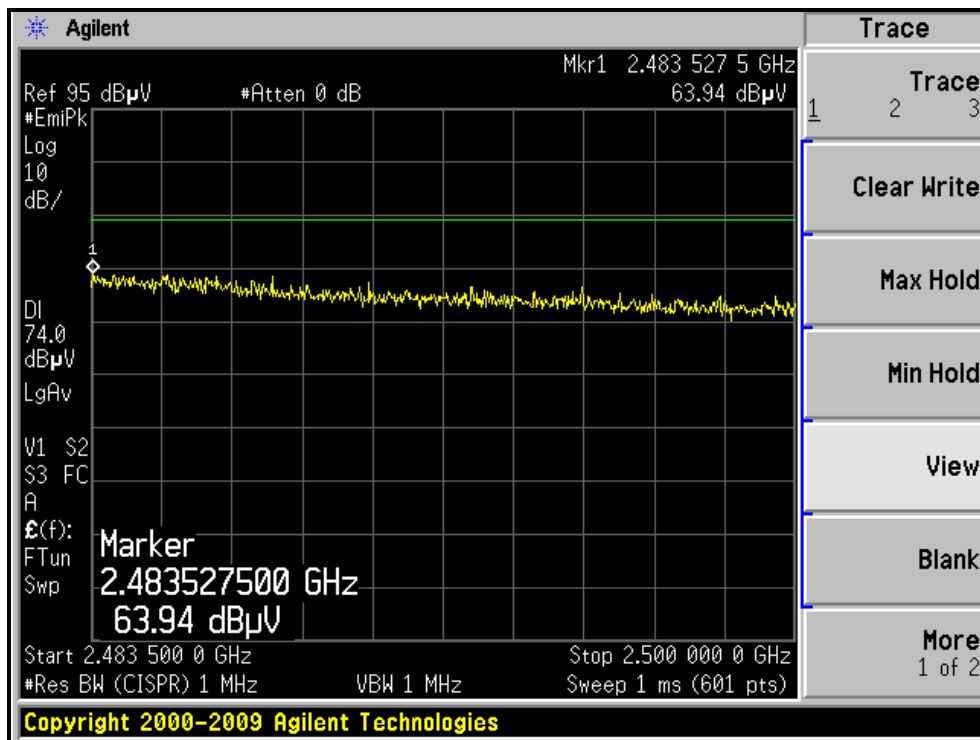



A D T

802.11n (20MHz) OFDM MODULATION

EUT TEST CONDITION		MEASUREMENT DETAIL	
CHANNEL	Channel 1	FREQUENCY RANGE	1 ~ 25GHz
INPUT POWER	120Vac, 60Hz	DETECTOR FUNCTION	Peak (PK) Average (AV)
ENVIRONMENTAL CONDITIONS	15deg. C, 61%RH	TESTED BY	Evan Huang

ANTENNA POLARITY & TEST DISTANCE: HORIZONTAL AT 3 M

NO.	FREQ. (MHz)	EMISSION LEVEL (dBuV/m)	LIMIT (dBuV/m)	MARGIN (dB)	ANTENNA HEIGHT (m)	TABLE ANGLE (Degree)	RAW VALUE (dBuV)	CORRECTION FACTOR (dB/m)
1	2390.00	60.5 PK	74.0	-13.5	1.00 H	294	28.75	31.75
2	2390.00	47.3 AV	54.0	-6.7	1.00 H	294	15.55	31.75
3	*2412.00	102.6 PK			1.00 H	294	70.78	31.82
4	*2412.00	93.5 AV			1.00 H	294	61.68	31.82
5	4824.00	46.6 PK	74.0	-27.4	1.07 H	285	7.24	39.36
6	4824.00	34.8 AV	54.0	-19.2	1.07 H	285	-4.56	39.36

ANTENNA POLARITY & TEST DISTANCE: VERTICAL AT 3 M

NO.	FREQ. (MHz)	EMISSION LEVEL (dBuV/m)	LIMIT (dBuV/m)	MARGIN (dB)	ANTENNA HEIGHT (m)	TABLE ANGLE (Degree)	RAW VALUE (dBuV)	CORRECTION FACTOR (dB/m)
1	2390.00	66.3 PK	74.0	-7.7	1.19 V	324	34.55	31.75
2	2390.00	53.4 AV	54.0	-0.6	1.19 V	324	21.65	31.75
3	*2412.00	111.5 PK			1.14 V	312	79.68	31.82
4	*2412.00	101.3 AV			1.14 V	312	69.48	31.82
5	4824.00	48.4 PK	74.0	-25.6	1.10 V	118	9.04	39.36
6	4824.00	37.8 AV	54.0	-16.2	1.10 V	118	-1.56	39.36

- REMARKS:**
1. Emission level (dBuV/m) = Raw Value (dBuV) + Correction Factor (dB/m).
 2. Correction Factor (dB/m) = Antenna Factor (dB/m) + Cable Factor (dB).
 3. The other emission levels were very low against the limit.
 4. Margin value = Emission level – Limit value.
 5. “ * “: Fundamental frequency.



A D T

EUT TEST CONDITION		MEASUREMENT DETAIL	
CHANNEL	Channel 6	FREQUENCY RANGE	1 ~ 25GHz
INPUT POWER	120Vac, 60Hz	DETECTOR FUNCTION	Peak (PK) Average (AV)
ENVIRONMENTAL CONDITIONS	15deg. C, 61%RH	TESTED BY	Evan Huang

ANTENNA POLARITY & TEST DISTANCE: HORIZONTAL AT 3 M								
NO.	FREQ. (MHz)	EMISSION LEVEL (dBuV/m)	LIMIT (dBuV/m)	MARGIN (dB)	ANTENNA HEIGHT (m)	TABLE ANGLE (Degree)	RAW VALUE (dBuV)	CORRECTION FACTOR (dB/m)
1	2390.00	55.7 PK	74.0	-18.3	1.01 H	261	23.95	31.75
2	2390.00	44.2 AV	54.0	-9.8	1.01 H	261	12.45	31.75
3	*2437.00	103.5 PK			1.00 H	260	71.58	31.92
4	*2437.00	94.0 AV			1.00 H	260	62.08	31.92
5	2483.50	55.9 PK	74.0	-18.1	1.00 H	270	23.81	32.09
6	2483.50	44.6 AV	54.0	-9.4	1.00 H	270	12.51	32.09
7	4874.00	46.6 PK	74.0	-27.4	1.02 H	296	7.10	39.50
8	4874.00	35.0 AV	54.0	-19.0	1.02 H	296	-4.50	39.50
9	7311.00	54.6 PK	74.0	-19.4	1.19 H	30	7.72	46.88
10	7311.00	43.5 AV	54.0	-10.5	1.19 H	30	-3.38	46.88
ANTENNA POLARITY & TEST DISTANCE: VERTICAL AT 3 M								
NO.	FREQ. (MHz)	EMISSION LEVEL (dBuV/m)	LIMIT (dBuV/m)	MARGIN (dB)	ANTENNA HEIGHT (m)	TABLE ANGLE (Degree)	RAW VALUE (dBuV)	CORRECTION FACTOR (dB/m)
1	2359.80	63.2 PK	74.0	-10.8	1.10 V	320	31.54	31.66
2	2359.80	53.5 AV	54.0	-0.5	1.10 V	320	21.84	31.66
3	*2437.00	114.6 PK			1.10 V	325	82.68	31.92
4	*2437.00	104.0 AV			1.10 V	325	72.08	31.92
5	2496.70	62.1 PK	74.0	-11.9	1.12 V	39	29.96	32.14
6	2496.70	52.5 AV	54.0	-1.5	1.12 V	39	20.36	32.14
7	4874.00	48.1 PK	74.0	-25.9	1.14 V	121	8.60	39.50
8	4874.00	37.5 AV	54.0	-16.5	1.14 V	121	-2.00	39.50
9	7311.00	53.8 PK	74.0	-20.2	1.34 V	217	6.92	46.88
10	7311.00	43.4 AV	54.0	-10.6	1.34 V	217	-3.48	46.88

- REMARKS:**
1. Emission level (dBuV/m) = Raw Value (dBuV) + Correction Factor (dB/m).
 2. Correction Factor (dB/m) = Antenna Factor (dB/m) + Cable Factor (dB).
 3. The other emission levels were very low against the limit.
 4. Margin value = Emission level – Limit value.
 5. “ * ”: Fundamental frequency.



A D T

EUT TEST CONDITION		MEASUREMENT DETAIL	
CHANNEL	Channel 11	FREQUENCY RANGE	1 ~ 25GHz
INPUT POWER	120Vac, 60Hz	DETECTOR FUNCTION	Peak (PK) Average (AV)
ENVIRONMENTAL CONDITIONS	15deg. C, 61%RH	TESTED BY	Evan Huang

ANTENNA POLARITY & TEST DISTANCE: HORIZONTAL AT 3 M								
NO.	FREQ. (MHz)	EMISSION LEVEL (dBuV/m)	LIMIT (dBuV/m)	MARGIN (dB)	ANTENNA HEIGHT (m)	TABLE ANGLE (Degree)	RAW VALUE (dBuV)	CORRECTION FACTOR (dB/m)
1	*2462.00	104.0 PK			1.00 H	258	71.99	32.01
2	*2462.00	94.5 AV			1.00 H	258	62.49	32.01
3	2483.50	62.7 PK	74.0	-11.3	1.05 H	258	30.61	32.09
4	2483.50	48.8 AV	54.0	-5.2	1.05 H	258	16.71	32.09
5	4924.00	46.5 PK	74.0	-27.5	1.08 H	294	6.83	39.67
6	4924.00	35.0 AV	54.0	-19.0	1.08 H	294	-4.67	39.67
7	7386.00	54.2 PK	74.0	-19.8	1.17 H	30	7.40	46.80
8	7386.00	43.1 AV	54.0	-10.9	1.17 H	30	-3.70	46.80
ANTENNA POLARITY & TEST DISTANCE: VERTICAL AT 3 M								
NO.	FREQ. (MHz)	EMISSION LEVEL (dBuV/m)	LIMIT (dBuV/m)	MARGIN (dB)	ANTENNA HEIGHT (m)	TABLE ANGLE (Degree)	RAW VALUE (dBuV)	CORRECTION FACTOR (dB/m)
1	*2462.00	112.6 PK			1.14 V	323	80.59	32.01
2	*2462.00	102.2 AV			1.14 V	323	70.19	32.01
3	2483.50	65.2 PK	74.0	-8.8	1.12 V	360	33.11	32.09
4	2483.50	53.2 AV	54.0	-0.8	1.12 V	360	21.11	32.09
5	4924.00	47.8 PK	74.0	-26.2	1.17 V	130	8.13	39.67
6	4924.00	37.2 AV	54.0	-16.8	1.17 V	130	-2.47	39.67
7	7386.00	53.8 PK	74.0	-20.2	1.33 V	203	7.00	46.80
8	7386.00	43.7 AV	54.0	-10.3	1.33 V	203	-3.10	46.80

- REMARKS:**
1. Emission level (dBuV/m) = Raw Value (dBuV) + Correction Factor (dB/m).
 2. Correction Factor (dB/m) = Antenna Factor (dB/m) + Cable Factor (dB).
 3. The other emission levels were very low against the limit.
 4. Margin value = Emission level – Limit value.
 5. “ * “: Fundamental frequency.



A D T

RESTRICTED BANDEDGE (802.11n (20MHz) MODE,CH1, HORIZONTAL)

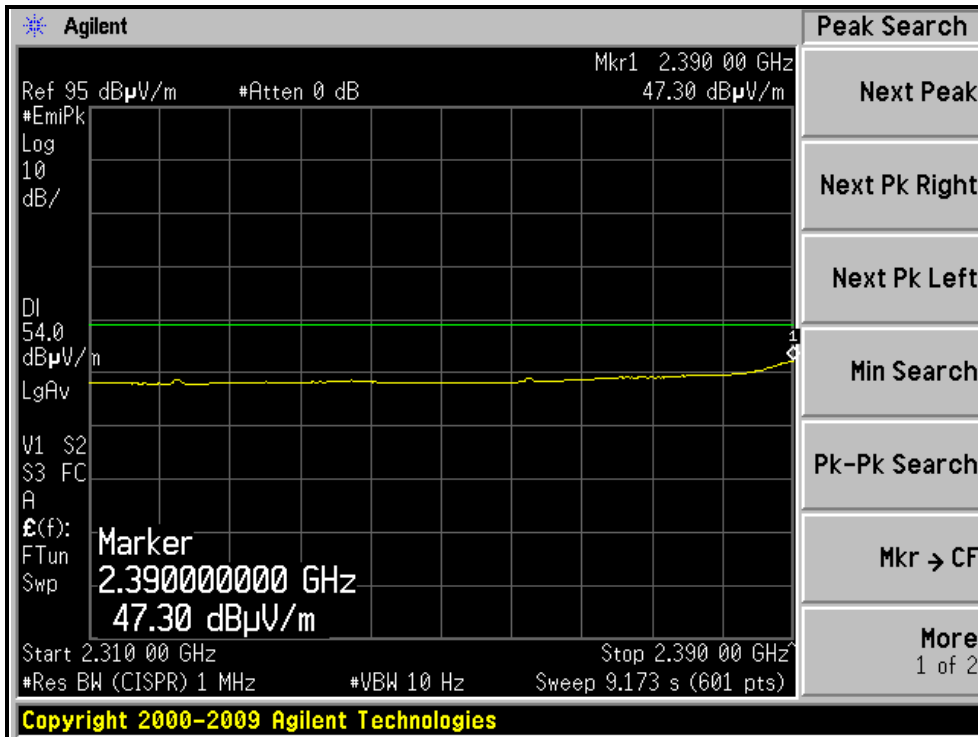
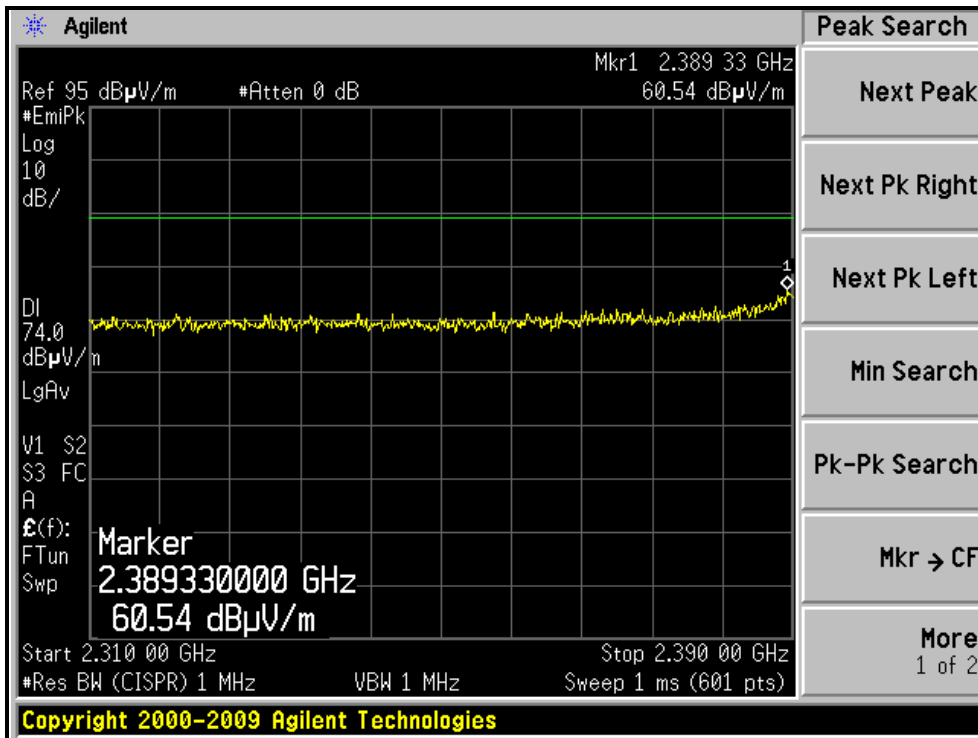



A D T

RESTRICTED BANDEDGE (802.11n (20MHz) MODE,CH1, VERTICAL)

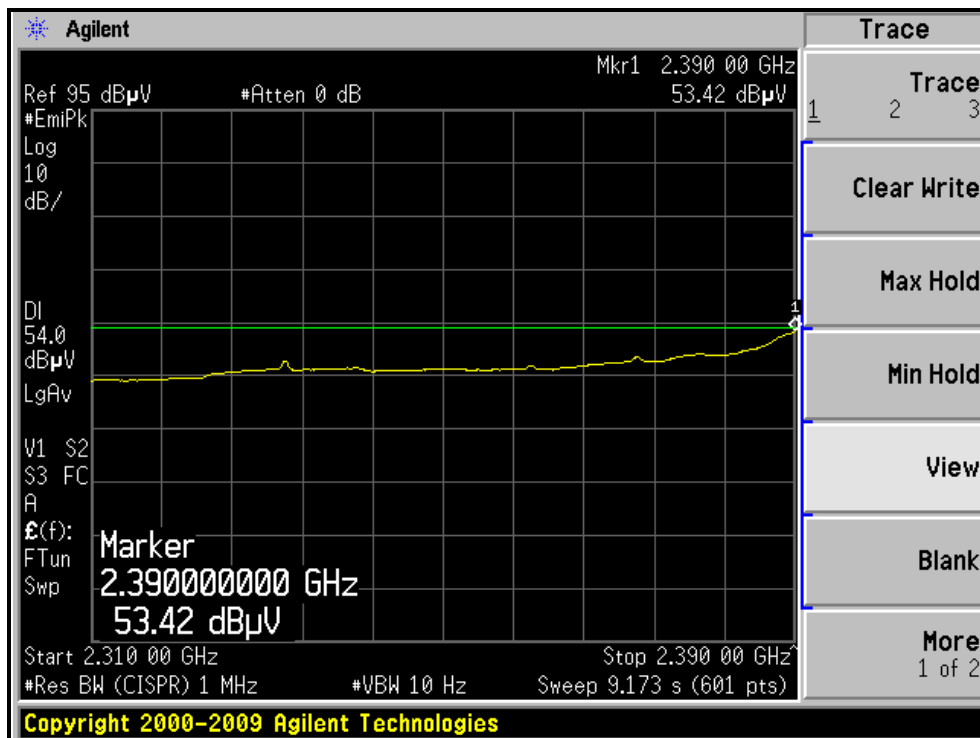
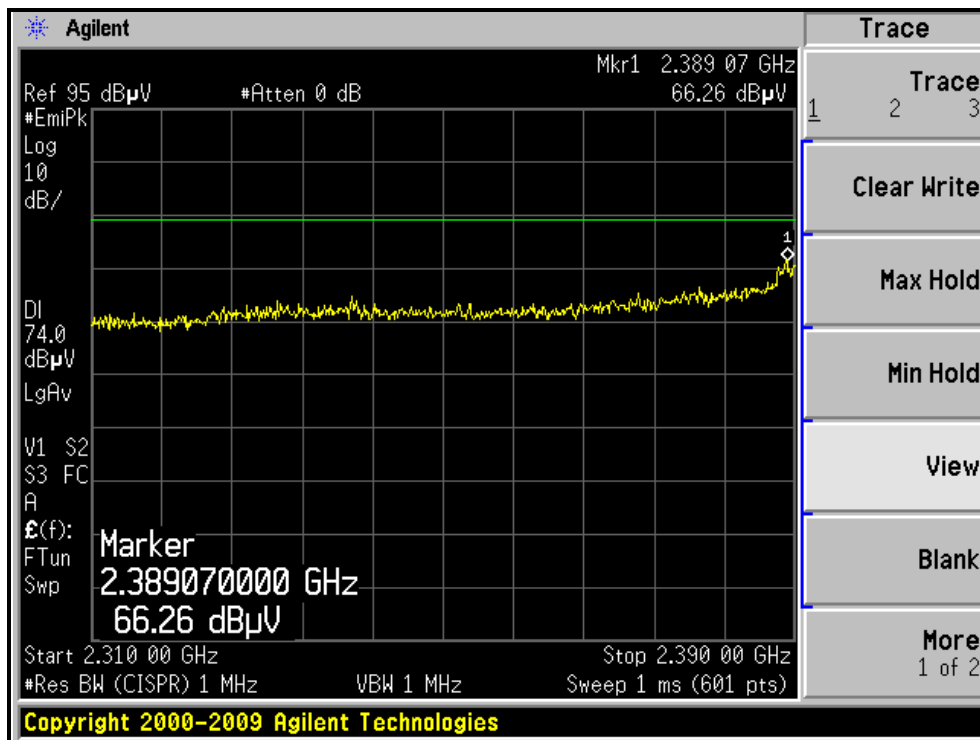



A D T

RESTRICTED BANDEDGE (802.11n (20MHz) MODE,CH11, HORIZONTAL)

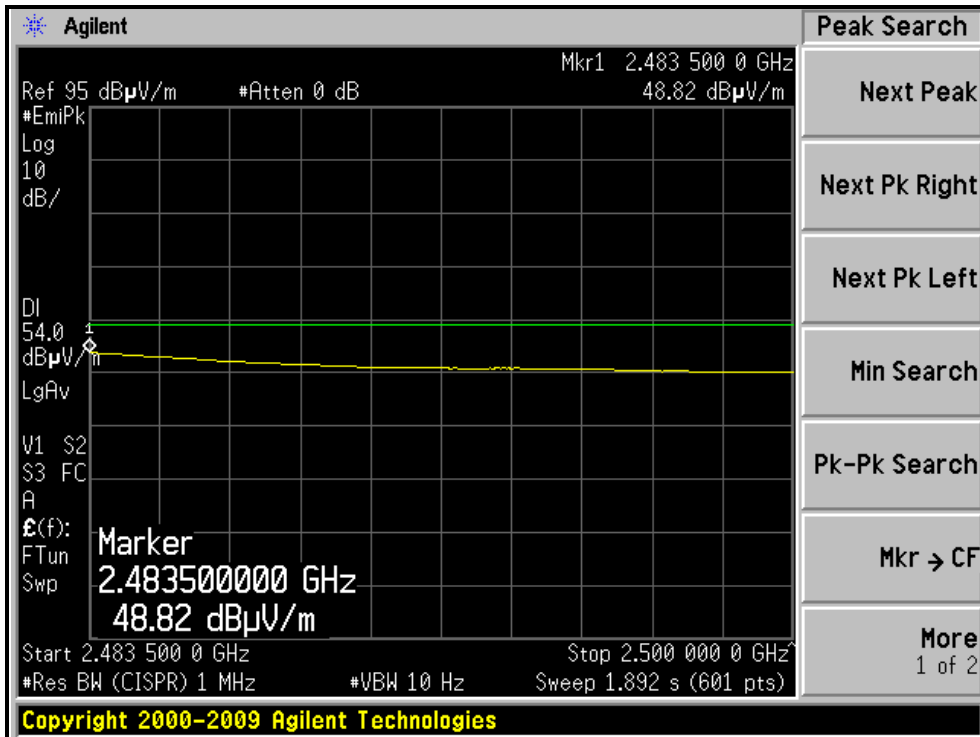
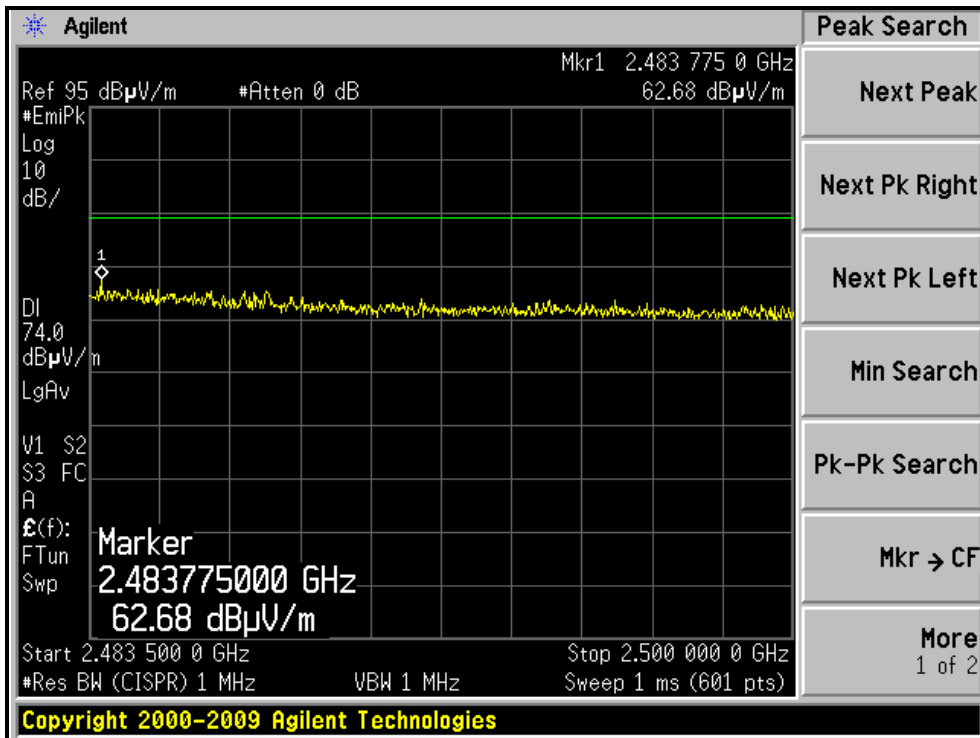



A D T

RESTRICTED BANDEDGE (802.11n (20MHz) MODE,CH11, VERTICAL)

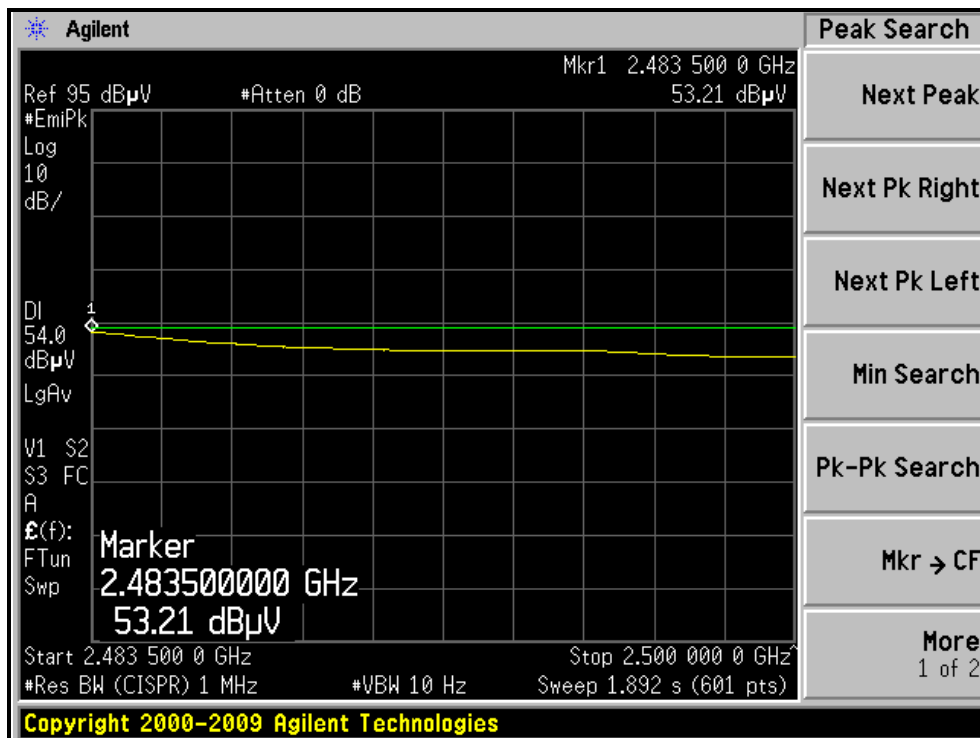
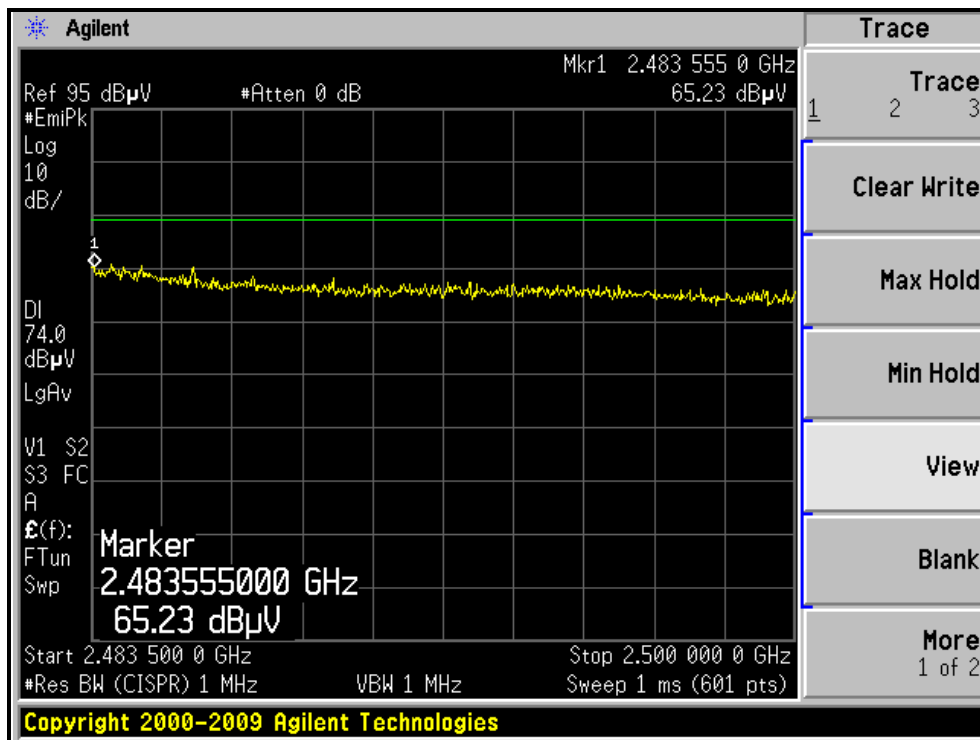



A D T

802.11n (40MHz) OFDM MODULATION

EUT TEST CONDITION		MEASUREMENT DETAIL	
CHANNEL	Channel 3	FREQUENCY RANGE	1 ~ 25GHz
INPUT POWER	120Vac, 60Hz	DETECTOR FUNCTION	Peak (PK) Average (AV)
ENVIRONMENTAL CONDITIONS	15deg. C, 61%RH	TESTED BY	Evan Huang

ANTENNA POLARITY & TEST DISTANCE: HORIZONTAL AT 3 M

NO.	FREQ. (MHz)	EMISSION LEVEL (dBuV/m)	LIMIT (dBuV/m)	MARGIN (dB)	ANTENNA HEIGHT (m)	TABLE ANGLE (Degree)	RAW VALUE (dBuV)	CORRECTION FACTOR (dB/m)
1	2390.00	59.2 PK	74.0	-14.8	1.05 H	260	27.45	31.75
2	2390.00	46.3 AV	54.0	-7.7	1.05 H	260	14.55	31.75
3	*2422.00	101.6 PK			1.05 H	260	69.74	31.86
4	*2422.00	91.4 AV			1.05 H	260	59.54	31.86
5	4844.00	44.7 PK	74.0	-29.3	1.21 H	281	5.28	39.42
6	4844.00	33.6 AV	54.0	-20.4	1.21 H	281	-5.82	39.42
7	7266.00	53.4 PK	74.0	-20.6	1.07 H	33	6.49	46.91
8	7266.00	42.6 AV	54.0	-11.4	1.07 H	33	-4.31	46.91

ANTENNA POLARITY & TEST DISTANCE: VERTICAL AT 3 M

NO.	FREQ. (MHz)	EMISSION LEVEL (dBuV/m)	LIMIT (dBuV/m)	MARGIN (dB)	ANTENNA HEIGHT (m)	TABLE ANGLE (Degree)	RAW VALUE (dBuV)	CORRECTION FACTOR (dB/m)
1	2390.00	65.4 PK	74.0	-8.6	1.15 V	323	33.65	31.75
2	2390.00	53.3 AV	54.0	-0.7	1.15 V	323	21.55	31.75
3	*2422.00	106.8 PK			1.14 V	323	74.94	31.86
4	*2422.00	96.4 AV			1.14 V	323	64.54	31.86
5	4844.00	45.9 PK	74.0	-28.1	1.20 V	138	6.48	39.42
6	4844.00	35.4 AV	54.0	-18.6	1.20 V	138	-4.02	39.42
7	7266.00	53.1 PK	74.0	-20.9	1.37 V	195	6.19	46.91
8	7266.00	43.0 AV	54.0	-11.0	1.37 V	195	-3.91	46.91

- REMARKS:**
1. Emission level (dBuV/m) = Raw Value (dBuV) + Correction Factor (dB/m).
 2. Correction Factor (dB/m) = Antenna Factor (dB/m) + Cable Factor (dB).
 3. The other emission levels were very low against the limit.
 4. Margin value = Emission level – Limit value.
 5. “ * “: Fundamental frequency.



A D T

EUT TEST CONDITION		MEASUREMENT DETAIL	
CHANNEL	Channel 6	FREQUENCY RANGE	1 ~ 25GHz
INPUT POWER	120Vac, 60Hz	DETECTOR FUNCTION	Peak (PK) Average (AV)
ENVIRONMENTAL CONDITIONS	15deg. C, 61%RH	TESTED BY	Evan Huang

ANTENNA POLARITY & TEST DISTANCE: HORIZONTAL AT 3 M

NO.	FREQ. (MHz)	EMISSION LEVEL (dBuV/m)	LIMIT (dBuV/m)	MARGIN (dB)	ANTENNA HEIGHT (m)	TABLE ANGLE (Degree)	RAW VALUE (dBuV)	CORRECTION FACTOR (dB/m)
1	2390.00	55.6 PK	74.0	-18.4	1.04 H	268	23.85	31.75
2	2390.00	44.3 AV	54.0	-9.7	1.04 H	268	12.55	31.75
3	*2437.00	101.8 PK			1.05 H	254	69.88	31.92
4	*2437.00	92.0 AV			1.05 H	254	60.08	31.92
5	2483.50	55.8 PK	74.0	-18.2	1.04 H	270	23.71	32.09
6	2483.50	44.7 AV	54.0	-9.3	1.04 H	270	12.61	32.09
7	4874.00	44.6 PK	74.0	-29.4	1.23 H	280	5.10	39.50
8	4874.00	33.8 AV	54.0	-20.2	1.23 H	280	-5.70	39.50
9	7311.00	53.1 PK	74.0	-20.9	1.12 H	24	6.22	46.88
10	7311.00	42.3 AV	54.0	-11.7	1.12 H	24	-4.58	46.88

ANTENNA POLARITY & TEST DISTANCE: VERTICAL AT 3 M

NO.	FREQ. (MHz)	EMISSION LEVEL (dBuV/m)	LIMIT (dBuV/m)	MARGIN (dB)	ANTENNA HEIGHT (m)	TABLE ANGLE (Degree)	RAW VALUE (dBuV)	CORRECTION FACTOR (dB/m)
1	2390.00	62.8 PK	74.0	-11.2	1.13 V	30	31.03	31.75
2	2390.00	51.9 AV	54.0	-2.1	1.13 V	30	20.15	31.75
3	*2437.00	110.5 PK			1.12 V	324	78.58	31.92
4	*2437.00	100.5 AV			1.12 V	324	68.58	31.92
5	2483.50	63.0 PK	74.0	-11.0	1.13 V	30	30.91	32.09
6	2483.50	52.8 AV	54.0	-1.2	1.13 V	30	20.68	32.09
7	4874.00	45.8 PK	74.0	-28.2	1.17 V	126	6.30	39.50
8	4874.00	35.3 AV	54.0	-18.7	1.17 V	126	-4.20	39.50
9	7311.00	53.4 PK	74.0	-20.6	1.42 V	211	6.52	46.88
10	7311.00	43.0 AV	54.0	-11.0	1.42 V	211	-3.88	46.88

- REMARKS:**
1. Emission level (dBuV/m) = Raw Value (dBuV) + Correction Factor (dB/m).
 2. Correction Factor (dB/m) = Antenna Factor (dB/m) + Cable Factor (dB).
 3. The other emission levels were very low against the limit.
 4. Margin value = Emission level – Limit value.
 5. “ * ”: Fundamental frequency.



A D T

EUT TEST CONDITION		MEASUREMENT DETAIL	
CHANNEL	Channel 9	FREQUENCY RANGE	1 ~ 25GHz
INPUT POWER	120Vac, 60Hz	DETECTOR FUNCTION	Peak (PK) Average (AV)
ENVIRONMENTAL CONDITIONS	15deg. C, 61%RH	TESTED BY	Evan Huang

ANTENNA POLARITY & TEST DISTANCE: HORIZONTAL AT 3 M								
NO.	FREQ. (MHz)	EMISSION LEVEL (dBuV/m)	LIMIT (dBuV/m)	MARGIN (dB)	ANTENNA HEIGHT (m)	TABLE ANGLE (Degree)	RAW VALUE (dBuV)	CORRECTION FACTOR (dB/m)
1	*2452.00	101.5 PK			1.05 H	257	69.53	31.97
2	*2452.00	91.6 AV			1.05 H	257	59.63	31.97
3	2484.90	60.0 PK	74.0	-14.0	1.05 H	257	27.91	32.09
4	2484.90	47.9 AV	54.0	-6.1	1.05 H	257	15.81	32.09
5	4904.00	44.2 PK	74.0	-29.8	1.25 H	270	4.60	39.60
6	4904.00	33.5 AV	54.0	-20.5	1.25 H	270	-6.10	39.60
7	7356.00	53.7 PK	74.0	-20.3	1.09 H	16	6.87	46.83
8	7356.00	42.7 AV	54.0	-11.3	1.09 H	16	-4.13	46.83
ANTENNA POLARITY & TEST DISTANCE: VERTICAL AT 3 M								
NO.	FREQ. (MHz)	EMISSION LEVEL (dBuV/m)	LIMIT (dBuV/m)	MARGIN (dB)	ANTENNA HEIGHT (m)	TABLE ANGLE (Degree)	RAW VALUE (dBuV)	CORRECTION FACTOR (dB/m)
1	*2452.00	109.1 PK			1.13 V	324	77.15	31.97
2	*2452.00	98.9 AV			1.13 V	324	66.93	31.97
3	2483.50	63.7 PK	74.0	-10.3	1.13 V	35	31.61	32.09
4	2483.50	51.7 AV	54.0	-2.3	1.13 V	35	19.61	32.09
5	4904.00	45.3 PK	74.0	-28.7	1.17 V	137	5.70	39.60
6	4904.00	34.9 AV	54.0	-19.1	1.17 V	137	-4.70	39.60
7	7356.00	53.3 PK	74.0	-20.7	1.47 V	198	6.47	46.83
8	7356.00	42.6 AV	54.0	-11.4	1.47 V	198	-4.23	46.83

- REMARKS:**
1. Emission level (dBuV/m) = Raw Value (dBuV) + Correction Factor (dB/m).
 2. Correction Factor (dB/m) = Antenna Factor (dB/m) + Cable Factor (dB).
 3. The other emission levels were very low against the limit.
 4. Margin value = Emission level – Limit value.
 5. “ * “: Fundamental frequency.



A D T

RESTRICTED BANDEDGE (802.11n (40MHz) MODE,CH3, HORIZONTAL)

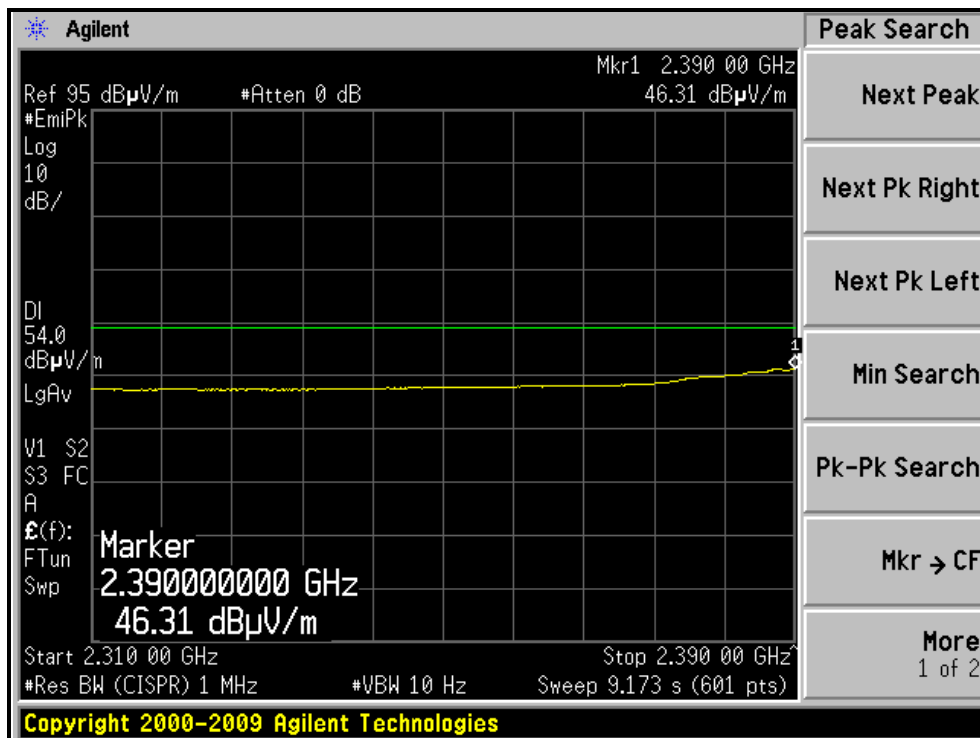
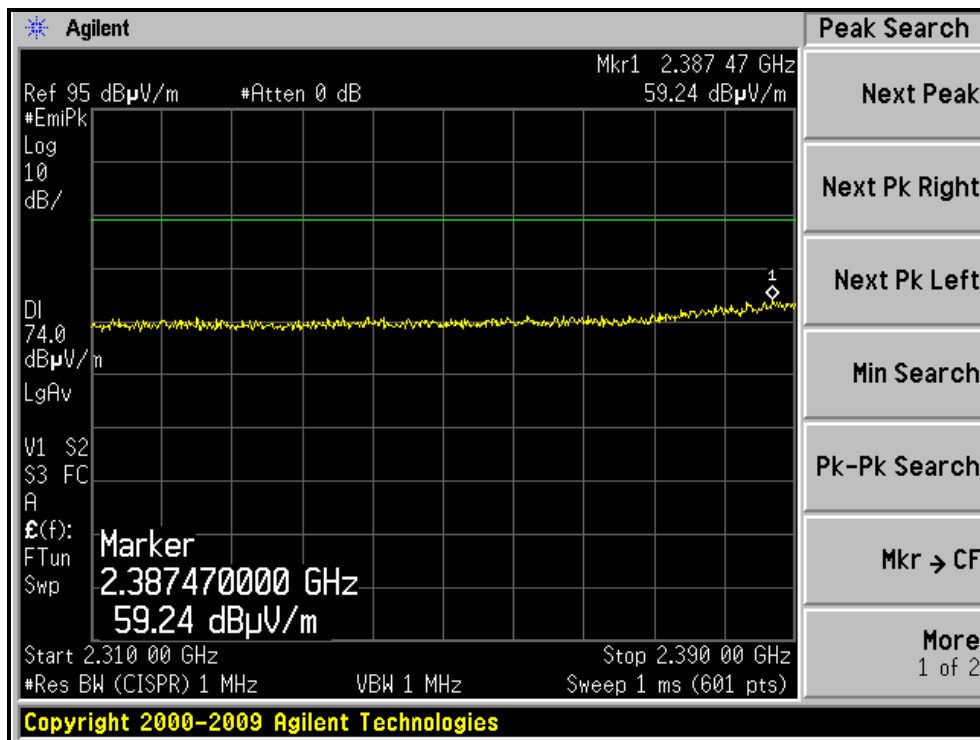

RESTRICTED BANDEDGE (802.11n (40MHz) MODE,CH3, VERTICAL)

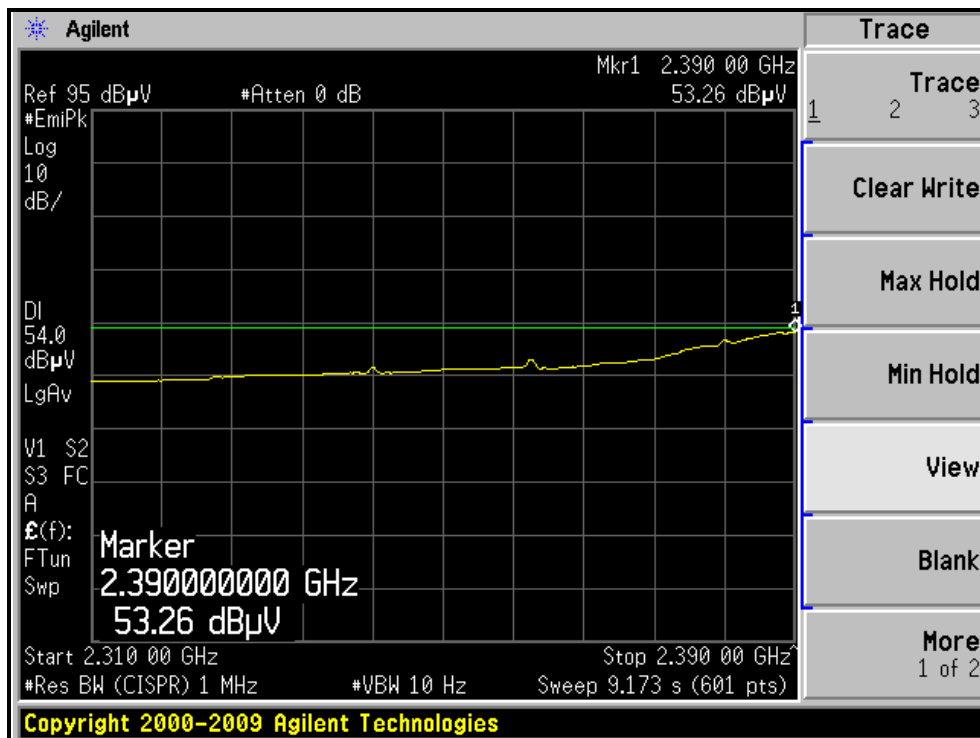
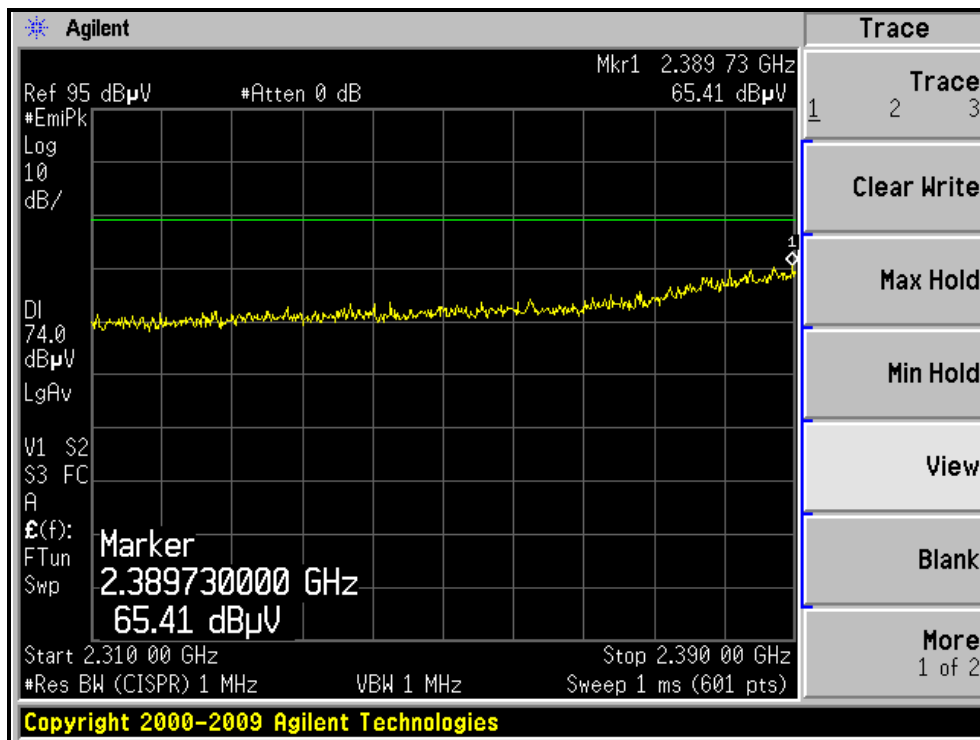

RESTRICTED BANDEDGE (802.11n (40MHz) MODE,CH9, HORIZONTAL)

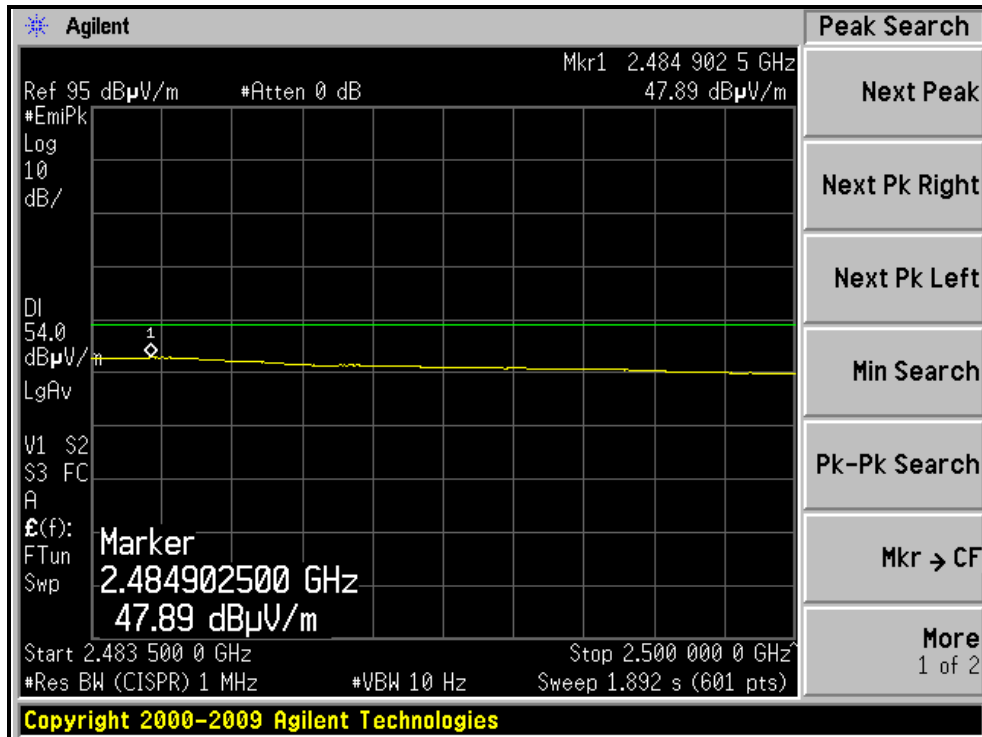
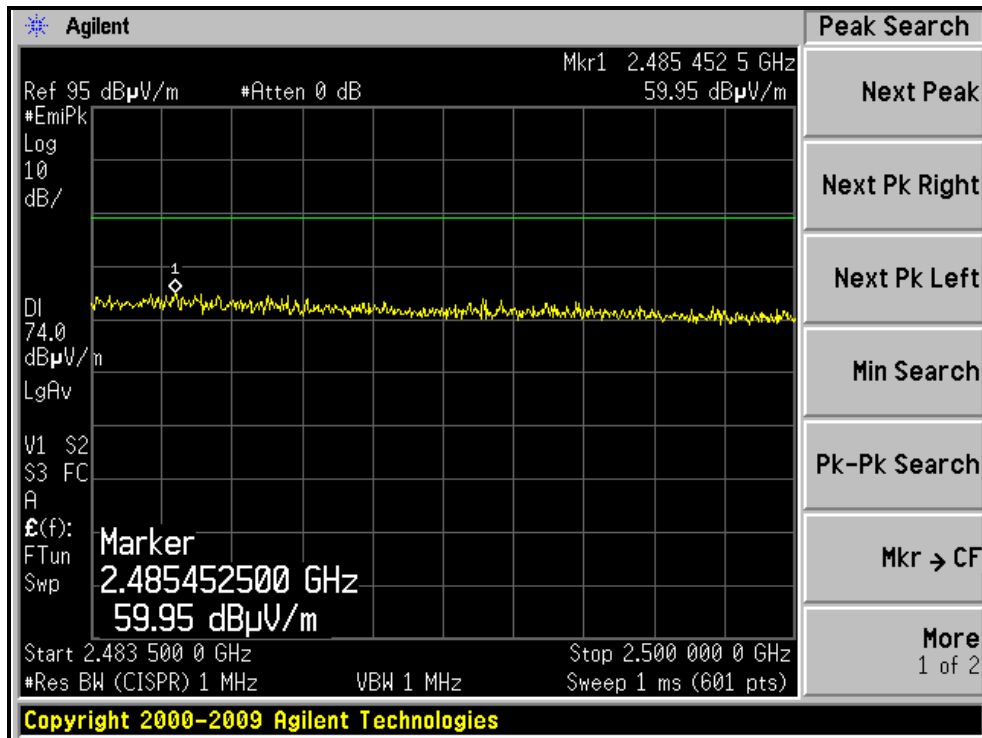



A D T

RESTRICTED BANDEDGE (802.11n (40MHz) MODE,CH9, VERTICAL)

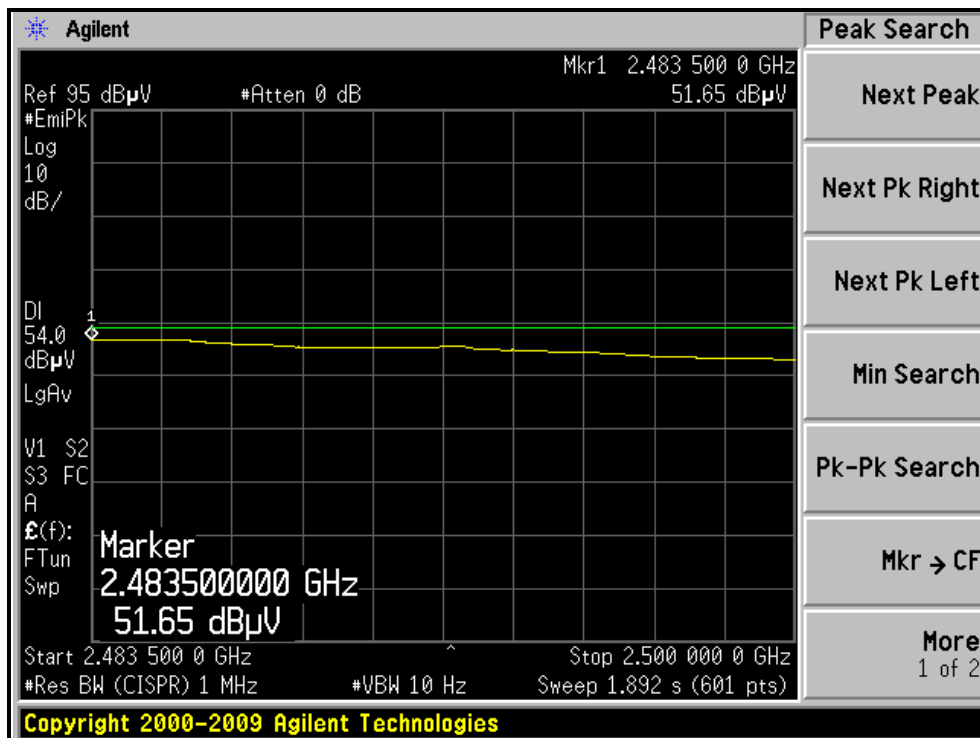
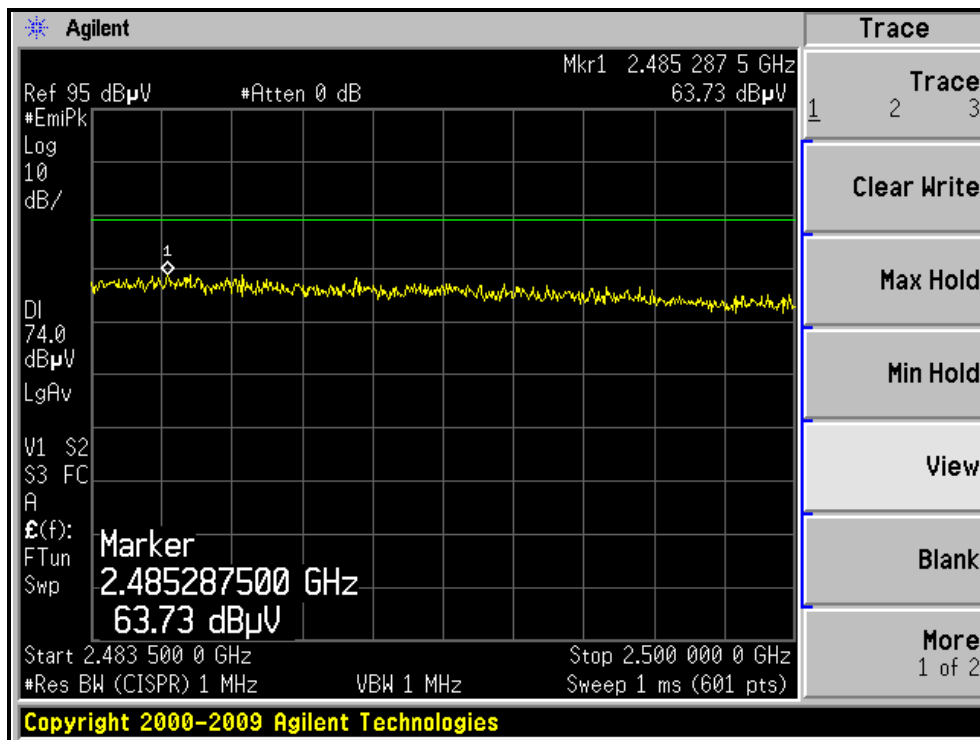

4.3 6dB BANDWIDTH MEASUREMENT

4.3.1 LIMITS OF 6dB BANDWIDTH MEASUREMENT

The minimum of 6dB Bandwidth Measurement is 0.5 MHz.

4.3.2 TEST INSTRUMENTS

Test date: Dec. 02, 2011

DESCRIPTION & MANUFACTURER	MODEL NO.	SERIAL NO.	CALIBRATED DATE	CALIBRATED UNTIL
R&S Spectrum Analyzer	FSP40	100036	Dec. 08, 2010	Dec. 07, 2011

NOTE: The calibration interval of the above test instruments is 12 months and the calibrations are traceable to NML/ROC and NIST/USA.

4.3.3 TEST PROCEDURE

The transmitter output was connected to the spectrum analyzer through an attenuator. The bandwidth of the fundamental frequency was measured by spectrum analyzer with 100kHz RBW and 300kHz VBW. The 6dB bandwidth is defined as the total spectrum the power of which is higher than peak power minus 6dB.

4.3.4 DEVIATION FROM TEST STANDARD

No deviation

4.3.5 TEST SETUP



4.3.6 EUT OPERATING CONDITIONS

The software provided by client to enable the EUT under transmission condition continuously at lowest, middle and highest channel frequencies individually.

4.3.7 TEST RESULTS

802.11b DSSS MODULATION:

CHANNEL	CHANNEL FREQUENCY (MHz)	6dB BANDWIDTH (MHz)	MINIMUM LIMIT (MHz)	PASS / FAIL
1	2412	9.36	0.5	PASS
6	2437	9.34	0.5	PASS
11	2462	9.10	0.5	PASS

CH1

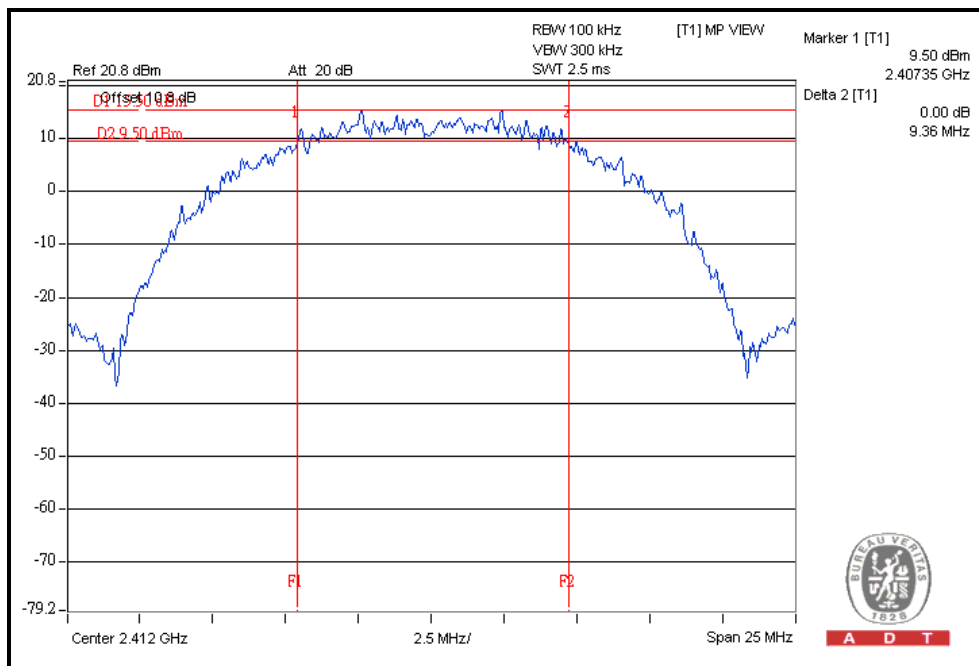

802.11g OFDM MODULATION:

CHANNEL	CHANNEL FREQUENCY (MHz)	6dB BANDWIDTH (MHz)	MINIMUM LIMIT (MHz)	PASS / FAIL
1	2412	16.58	0.5	PASS
6	2437	16.59	0.5	PASS
11	2462	16.57	0.5	PASS

CH6

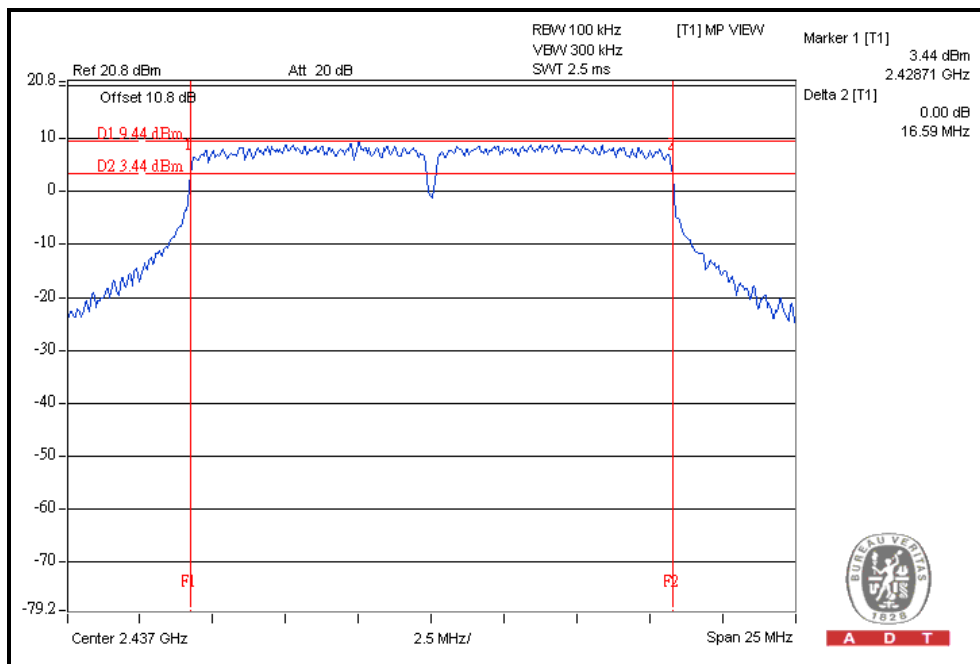



A D T

802.11n (20MHz) OFDM modulation:

CHANNEL	CHANNEL FREQUENCY (MHz)	6dB BANDWIDTH (MHz)		MINIMUM LIMIT (MHz)	PASS / FAIL
		CHAIN(0)	CHAIN(1)		
1	2412	17.81	17.74	0.5	PASS
6	2437	17.82	17.77	0.5	PASS
11	2462	17.77	17.73	0.5	PASS

For Chain(0) : CH6

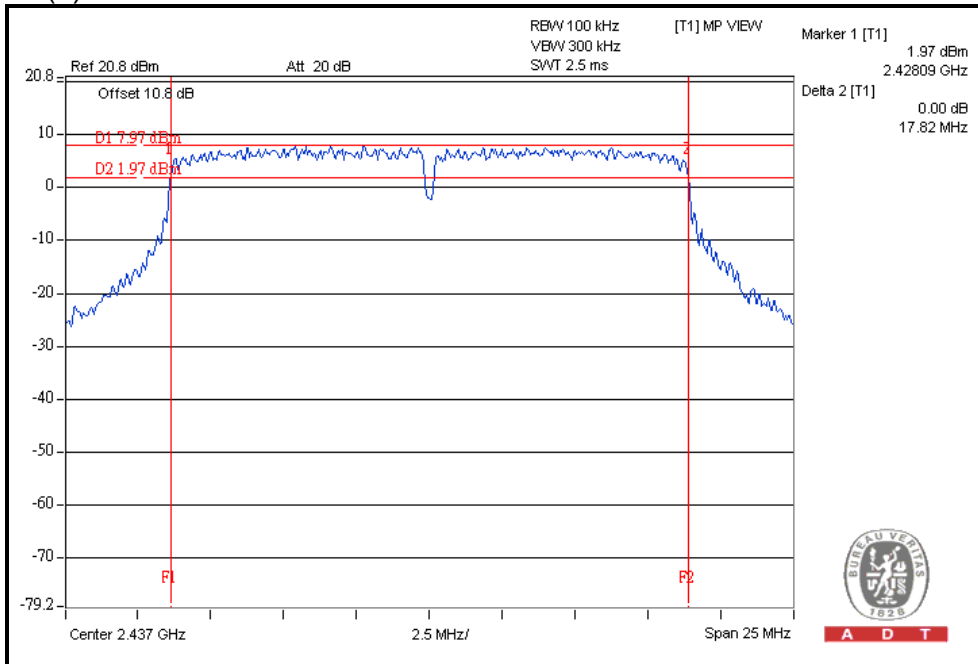



A D T

802.11n (40MHz) OFDM MODULATION:

CHANNEL	CHANNEL FREQUENCY (MHz)	6dB BANDWIDTH (MHz)		MINIMUM LIMIT (MHz)	PASS / FAIL
		CHAIN(0)	CHAIN(1)		
3	2422	36.51	36.46	0.5	PASS
6	2437	36.52	36.47	0.5	PASS
9	2452	36.52	36.46	0.5	PASS

For Chain(0) : CH9

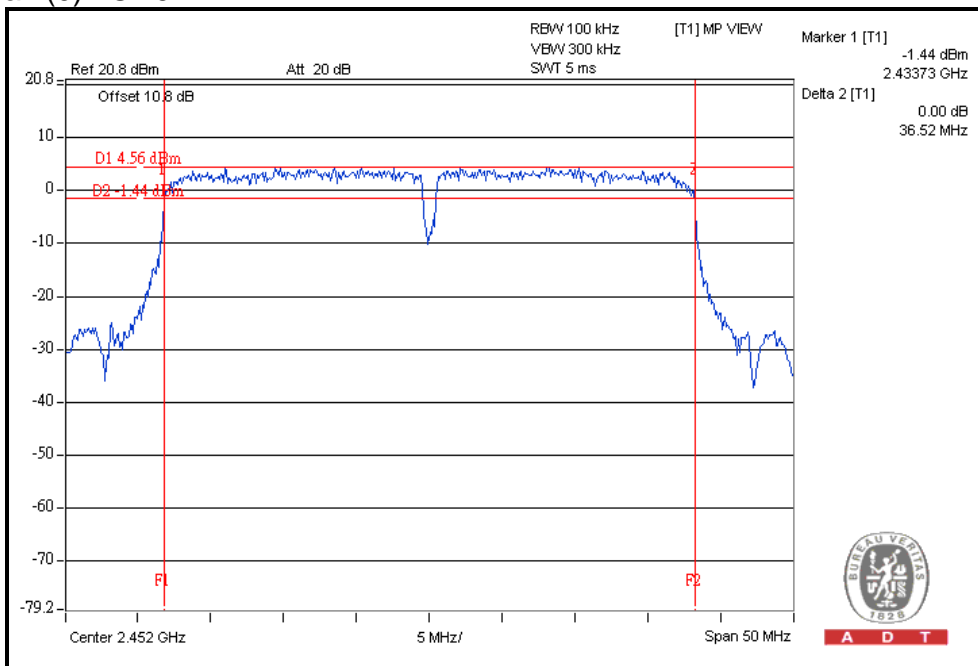

4.4 MAXIMUM PEAK OUTPUT POWER

4.4.1 LIMITS OF MAXIMUM PEAK OUTPUT POWER MEASUREMENT

The Maximum Peak Output Power Measurement is 30dBm.

4.4.2 INSTRUMENTS

Test date: Dec. 02, 2011

DESCRIPTION & MANUFACTURER	MODEL NO.	SERIAL NO.	CALIBRATED DATE	CALIBRATED UNTIL
Agilent SIGNAL GENERATOR	E8257C	MY43320668	Dec. 27, 2010	Dec. 26, 2011
TEKTRONIX OSCILLOSCOPE	TDS 5104	BO51450	May. 17, 2011	May. 16, 2012
NARDA DETECTOR	4503A	FSCM99899	NA	NA

NOTE: The calibration interval of the above test instruments is 12 months and the calibrations are traceable to NML/ROC and NIST/USA.

4.4.3 TEST PROCEDURES

1. A detector was used on the output port of the EUT. An oscilloscope was used to read the response of the detector.
2. Replaced the EUT by the signal generator. The center frequency of the S.G was adjusted to the center frequency of the measured channel.
3. Adjusted the power to have the same reading on oscilloscope. Record the power level.

4.4.4 DEVIATION FROM TEST STANDARD

No deviation

4.4.5 TEST SETUP

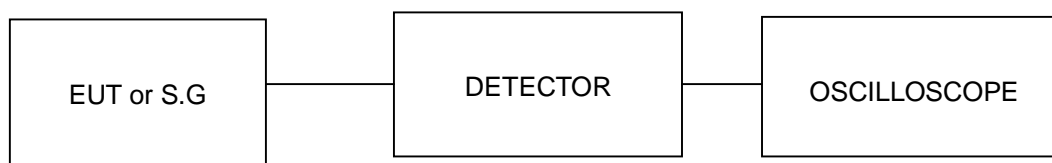

4.4.6 EUT OPERATING CONDITIONS

Same as Item 4.3.6



A D T

4.4.7 TEST RESULTS

802.11b DSSS MODULATION:

CHANNEL	CHANNEL FREQUENCY (MHz)	PEAK POWER OUTPUT (mW)	PEAK POWER OUTPUT (dBm)	PEAK POWER LIMIT (dBm)	PASS/FAIL
1	2412	239.9	23.8	30	PASS
6	2437	309.0	24.9	30	PASS
11	2462	323.6	25.1	30	PASS

802.11g OFDM MODULATION:

CHANNEL	CHANNEL FREQUENCY (MHz)	PEAK POWER OUTPUT (mW)	PEAK POWER OUTPUT (dBm)	PEAK POWER LIMIT (dBm)	PASS/FAIL
1	2412	363.1	25.6	30	PASS
6	2437	371.5	25.7	30	PASS
11	2462	407.4	26.1	30	PASS



A D T

802.11n (20MHz) OFDM MODULATION:

CHANNEL	CHANNEL FREQUENCY (MHz)	PEAK POWER OUTPUT (dBm)		TOTAL PEAK POWER (mW)	TOTAL PEAK POWER (dBm)	PEAK POWER LIMIT (dBm)	PASS / FAIL
		CHAIN(0)	CHAIN(1)				
1	2412	22.9	22.3	364.8	25.6	30	PASS
6	2437	25.1	24.1	580.6	27.6	30	PASS
11	2462	25.2	23.9	576.6	27.6	30	PASS

802.11n (40MHz) OFDM MODULATION:

CHANNEL	CHANNEL FREQUENCY (MHz)	PEAK POWER OUTPUT (dBm)		TOTAL PEAK POWER (mW)	TOTAL PEAK POWER (dBm)	PEAK POWER LIMIT (dBm)	PASS / FAIL
		CHAIN(0)	CHAIN(1)				
3	2422	22.3	21.3	304.7	24.8	30	PASS
6	2437	24.1	23.8	496.9	27.0	30	PASS
9	2452	24.6	23.9	533.9	27.3	30	PASS

4.5 POWER SPECTRAL DENSITY MEASUREMENT

4.5.1 LIMITS OF POWER SPECTRAL DENSITY MEASUREMENT

The Maximum of Power Spectral Density Measurement is 8dBm.

4.5.2 TEST INSTRUMENTS

Test date: Dec. 02, 2011

DESCRIPTION & MANUFACTURER	MODEL NO.	SERIAL NO.	CALIBRATED DATE	CALIBRATED UNTIL
R&S Spectrum Analyzer	FSP40	100036	Dec. 08, 2010	Dec. 07, 2011

NOTE: The calibration interval of the above test instruments is 12 months and the calibrations are traceable to NML/ROC and NIST/USA.

4.5.3 TEST PROCEDURE

The transmitter output was connected to the spectrum analyzer through an attenuator, the bandwidth of the fundamental frequency was measured with the spectrum analyzer using 3kHz RBW and 30kHz VBW, set sweep time = span/3kHz. The power spectral density was measured and recorded. The sweep time is allowed to be longer than span/3kHz for a full response of the mixer in the spectrum analyzer.

4.5.4 DEVIATION FROM TEST STANDARD

No deviation

4.5.5 TEST SETUP

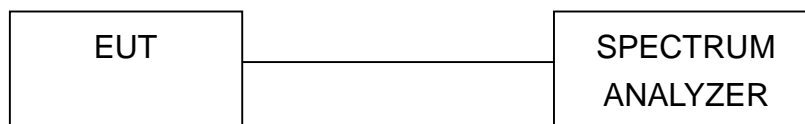

4.5.6 EUT OPERATING CONDITION

Same as Item 4.3.6



A D T

4.5.7 TEST RESULTS

802.11b DSSS MODULATION:

CHANNEL	FREQUENCY (MHz)	PSD (dBm/3kHz)	Limit (dBm/3kHz)	PASS / FAIL
1	2412	4.8	8	PASS
6	2437	2.9	8	PASS
11	2462	1.7	8	PASS

CH1

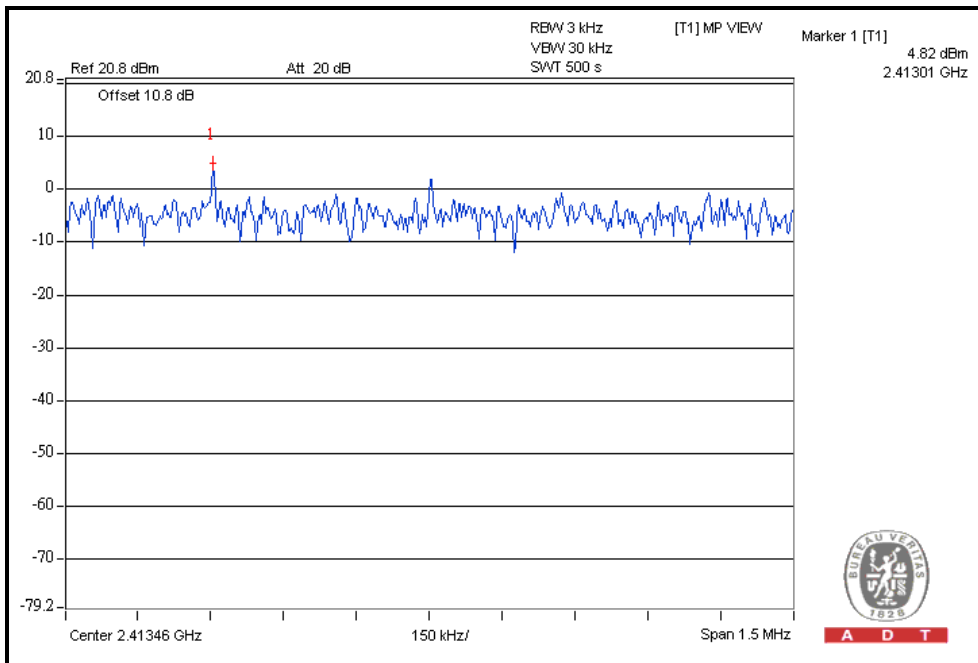



A D T

802.11g OFDM MODULATION:

CHANNEL	FREQUENCY (MHz)	PSD (dBm/3kHz)	Limit (dBm/3kHz)	PASS / FAIL
1	2412	-5.6	8	PASS
6	2437	-5.2	8	PASS
11	2462	-5.2	8	PASS

CH6

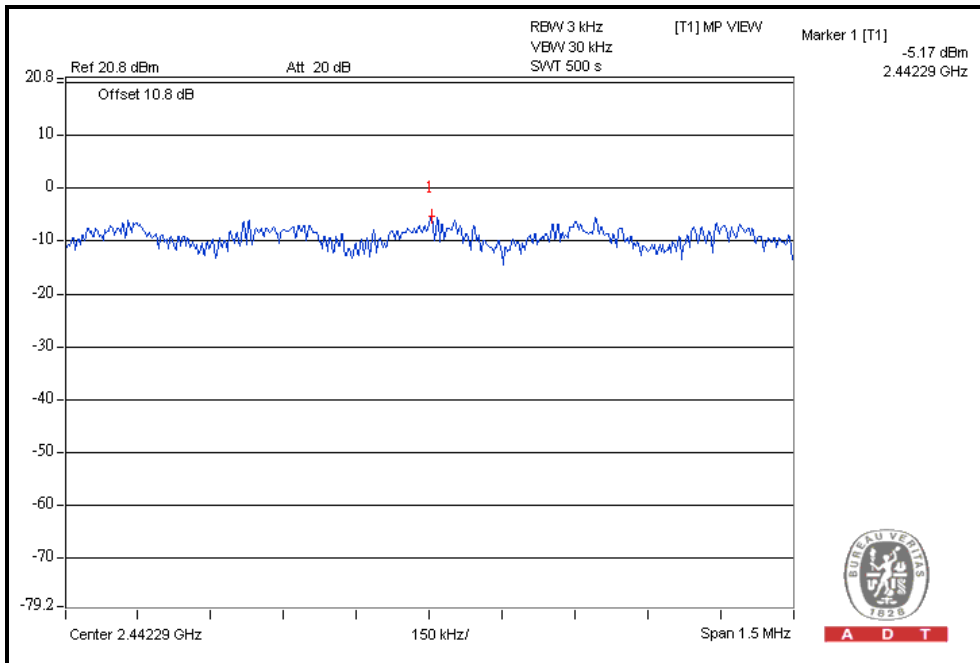



A D T

802.11n (20MHz) OFDM MODULATION:

TX chain	Channel	FREQ. (MHz)	PSD (dBm/3kHz)	10 log (N=2) dB	Total PSD (dBm/3kHz)	Limit (dBm/3kHz)	PASS /FAIL
0	1	2412	-6.8	3.0	-3.8	8	PASS
	6	2437	-4.6	3.0	-1.6	8	PASS
	11	2462	-5.5	3.0	-2.5	8	PASS
1	1	2412	-6.2	3.0	-3.2	8	PASS
	6	2437	-5.0	3.0	-2.0	8	PASS
	11	2462	-5.2	3.0	-2.2	8	PASS

For Chain(0): CH6

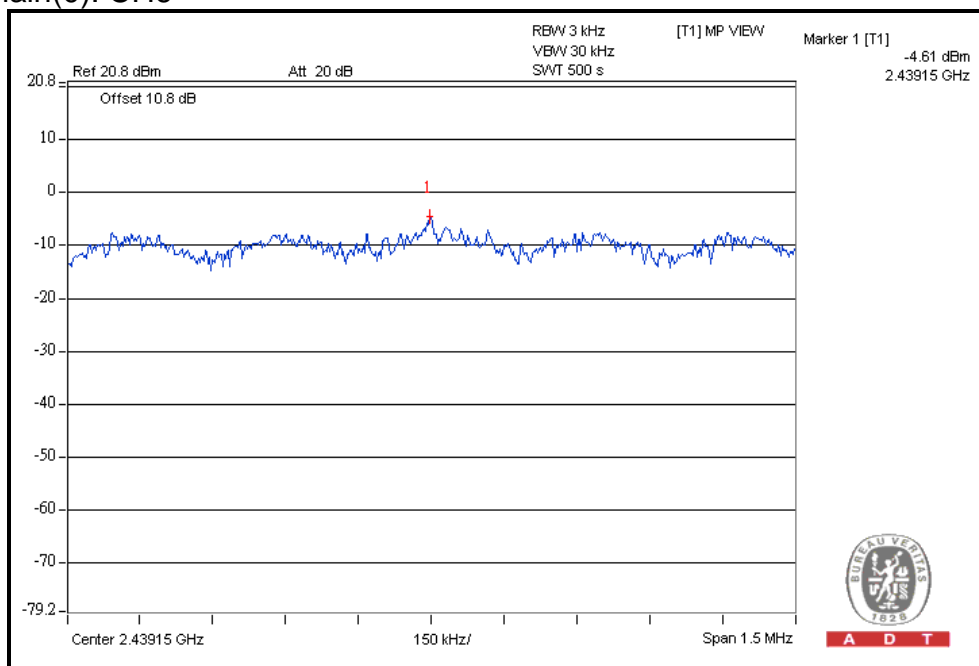



A D T

802.11n (40MHz) OFDM MODULATION:

TX chain	Channel	FREQ. (MHz)	PSD (dBm/3kHz)	10 log (N=2) dB	Total PSD (dBm/3kHz)	Limit (dBm/3kHz)	PASS /FAIL
0	3	2422	-9.9	3.0	-6.9	8	PASS
	6	2437	-7.1	3.0	-4.1	8	PASS
	9	2452	-7.3	3.0	-4.3	8	PASS
1	3	2422	-11.4	3.0	-8.4	8	PASS
	6	2437	-9.0	3.0	-6.0	8	PASS
	9	2452	-8.4	3.0	-5.4	8	PASS

For Chain(0): CH6

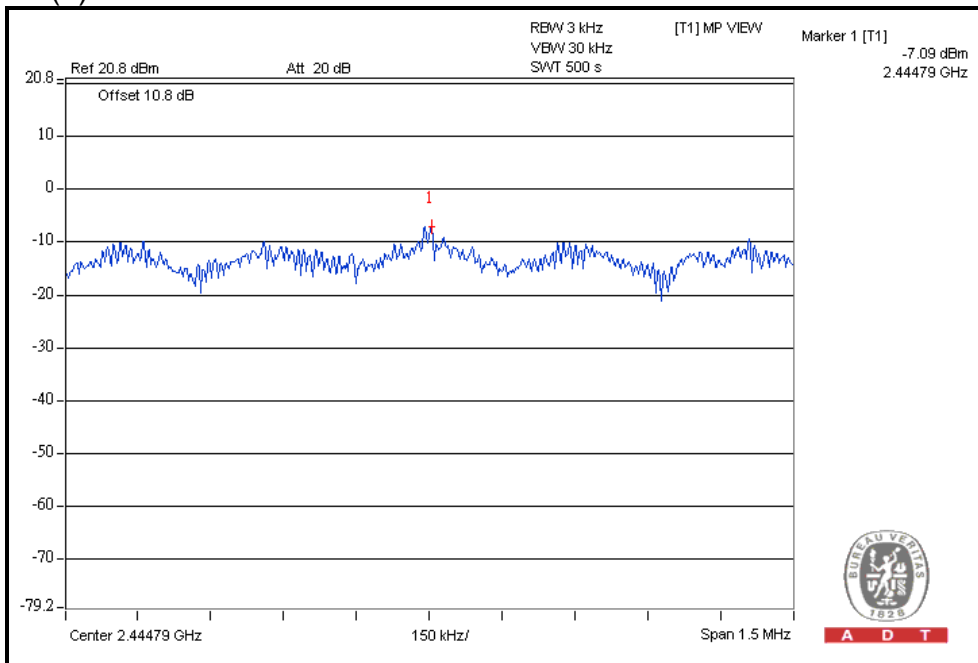

4.6 CONDUCTED OUT-BAND EMISSION MEASUREMENT

4.6.1 LIMITS OF CONDUCTED OUT-BAND EMISSION MEASUREMENT

Below -20dB of the highest emission level of operating band (in 100kHz Resolution Bandwidth).

4.6.2 TEST INSTRUMENTS

Test date: Dec. 02, 2011

DESCRIPTION & MANUFACTURER	MODEL NO.	SERIAL NO.	CALIBRATED DATE	CALIBRATED UNTIL
R&S Spectrum Analyzer	FSP40	100036	Dec. 08, 2010	Dec. 07, 2011

NOTE: The calibration interval of the above test instruments is 12 months and the calibrations are traceable to NML/ROC and NIST/USA.

4.6.3 TEST PROCEDURE

The transmitter output was connected to the spectrum analyzer via a low loss cable. Set RBW of spectrum analyzer to 100kHz and VBW of spectrum analyzer to 300kHz with suitable frequency span including 100MHz or 200MHz bandwidth from band edge. The band edges was measured and recorded.

The spectrum plots (RBW = 100kHz, VBW = 300kHz) are attached on the following pages.

4.6.4 DEVIATION FROM TEST STANDARD

No deviation

4.6.5 EUT OPERATING CONDITION

Same as Item 4.3.6

4.6.6 TEST RESULTS

The spectrum plots are attached on the following images. D1 line indicates the highest level, and D2 line indicates the 20dB offset below D1. It shows compliance with the requirement in part 15.247(d).



A D T

Performing measurements: Measure and add 10 log(N) dB 802.11b DSSS MODULATION:

CH1

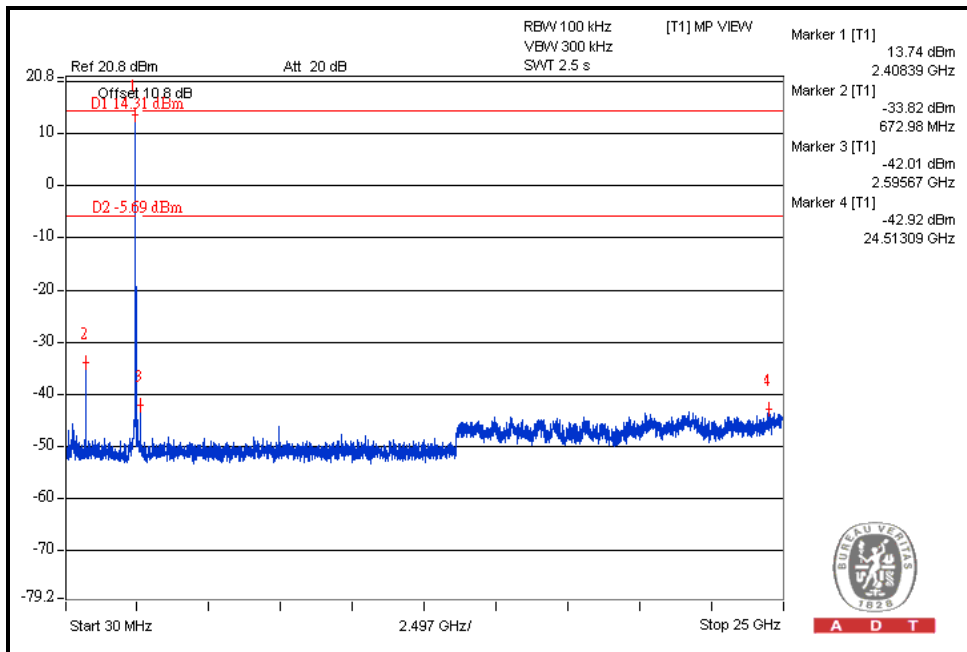
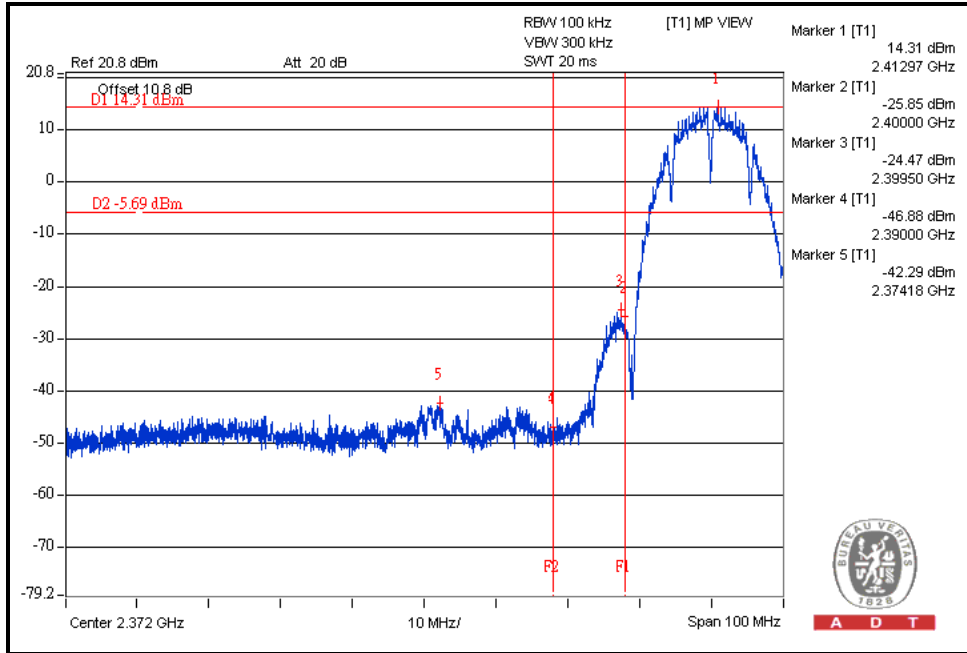



A D T

CH11

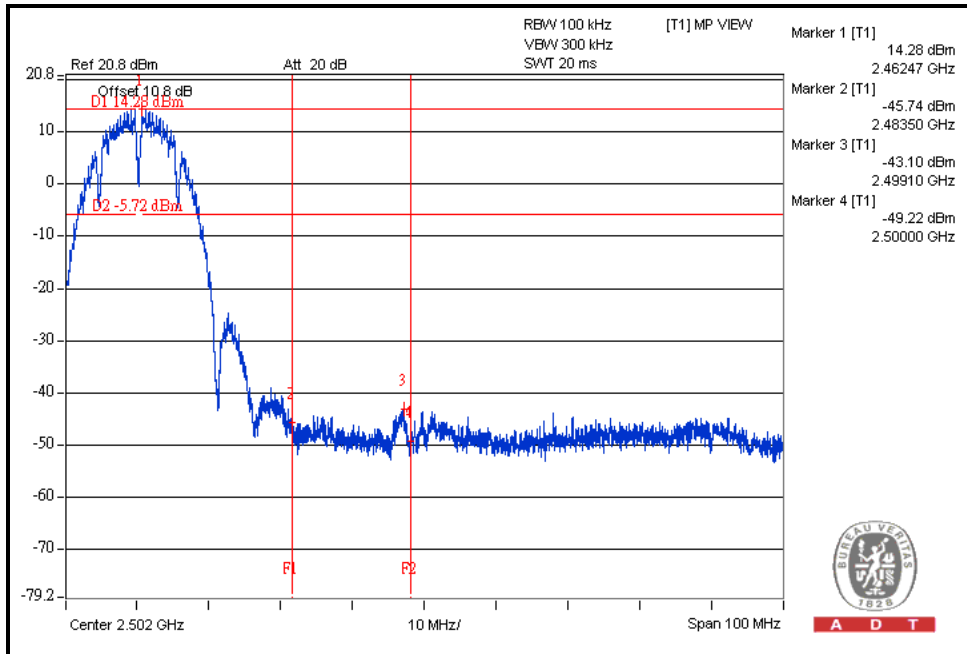

A D T

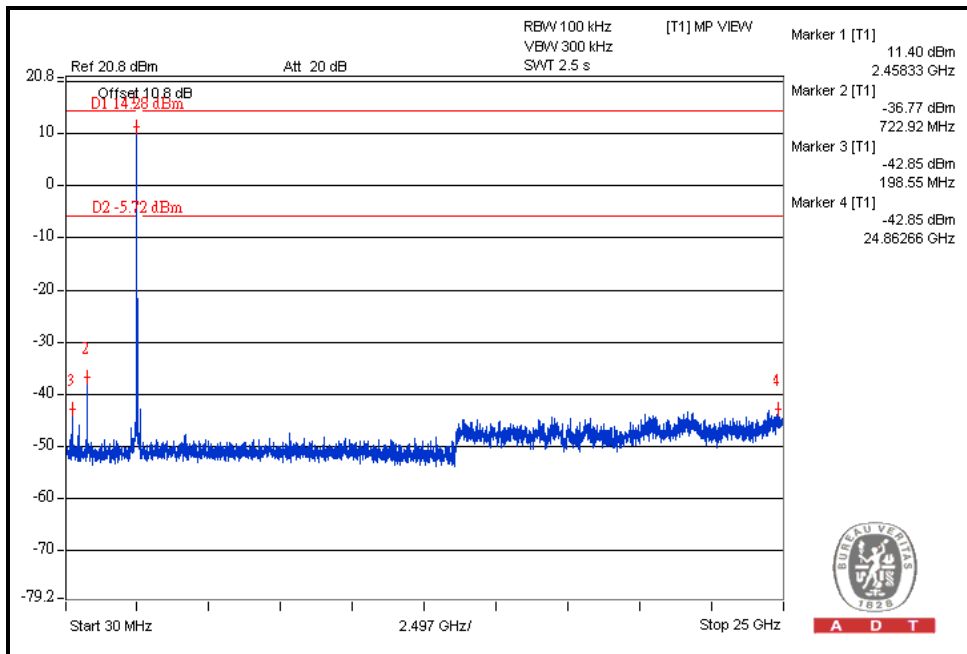

A D T



A D T

802.11g OFDM MODULATION:

CH1

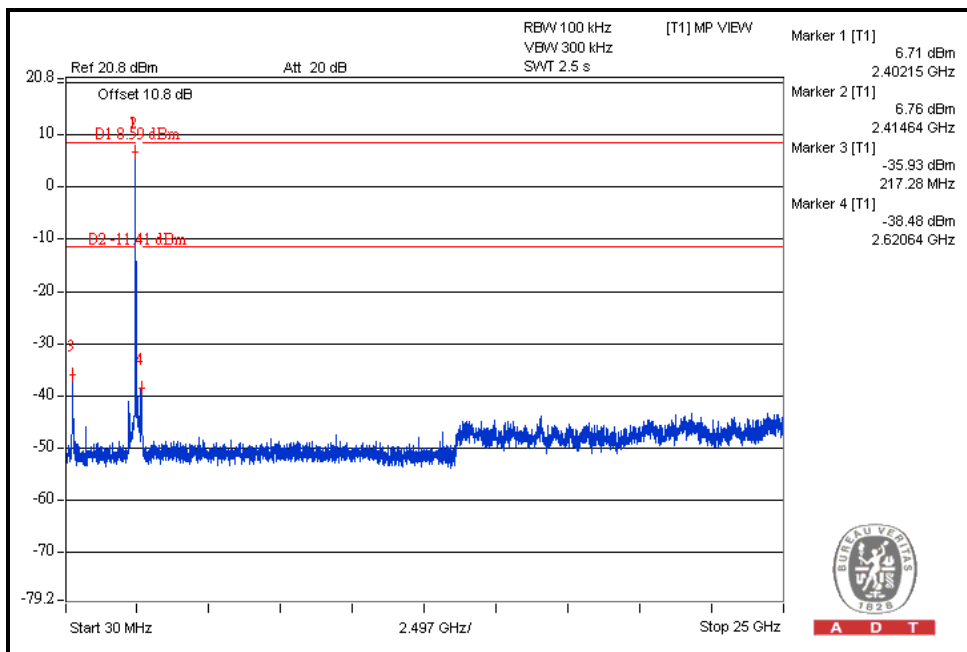
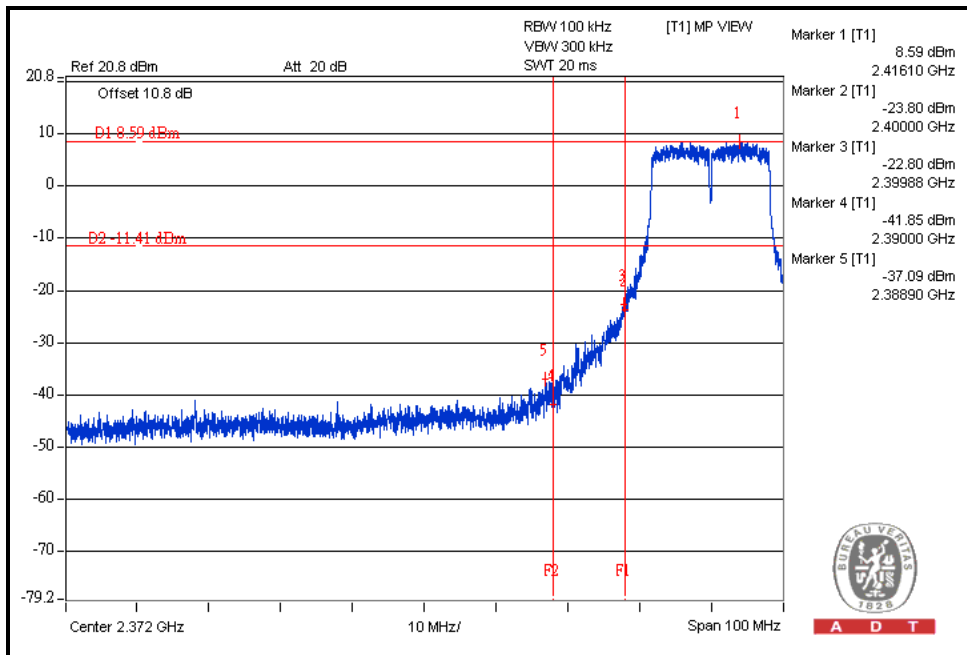



A D T

CH11

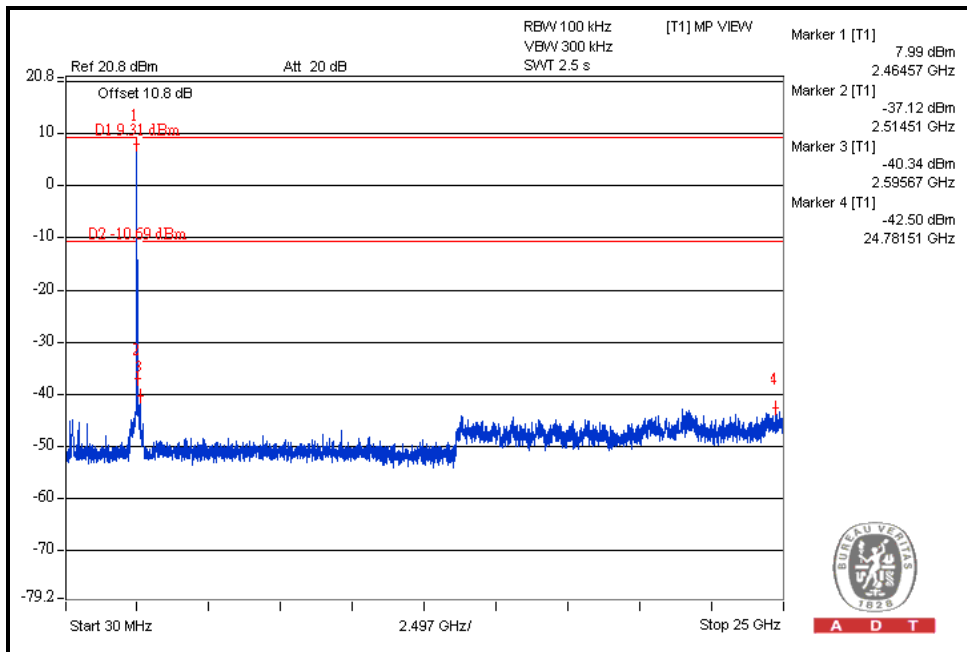
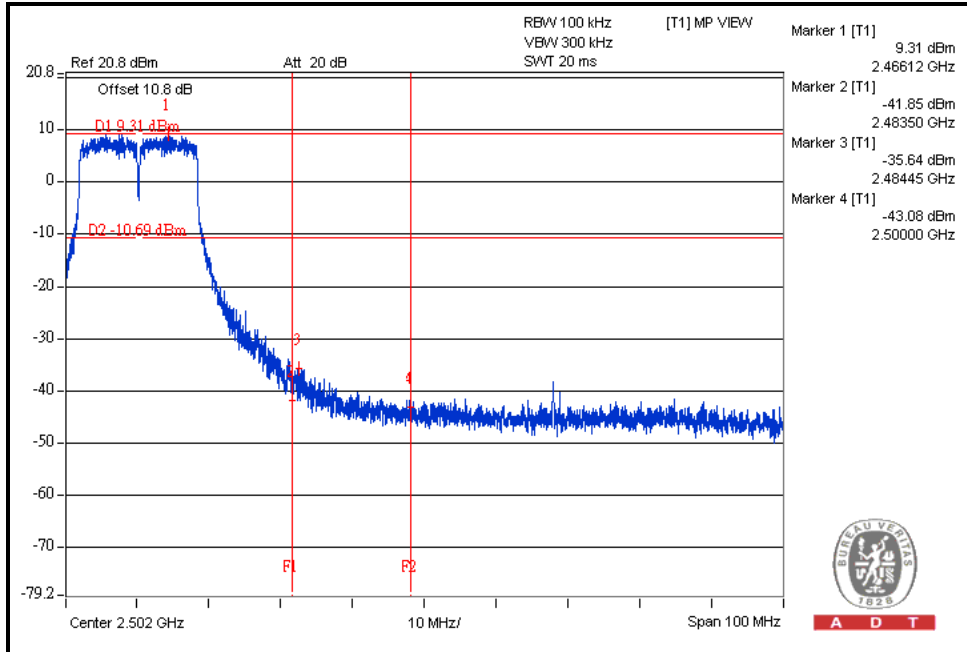



A D T

802.11n (20MHz) OFDM MODULATION:

CH1

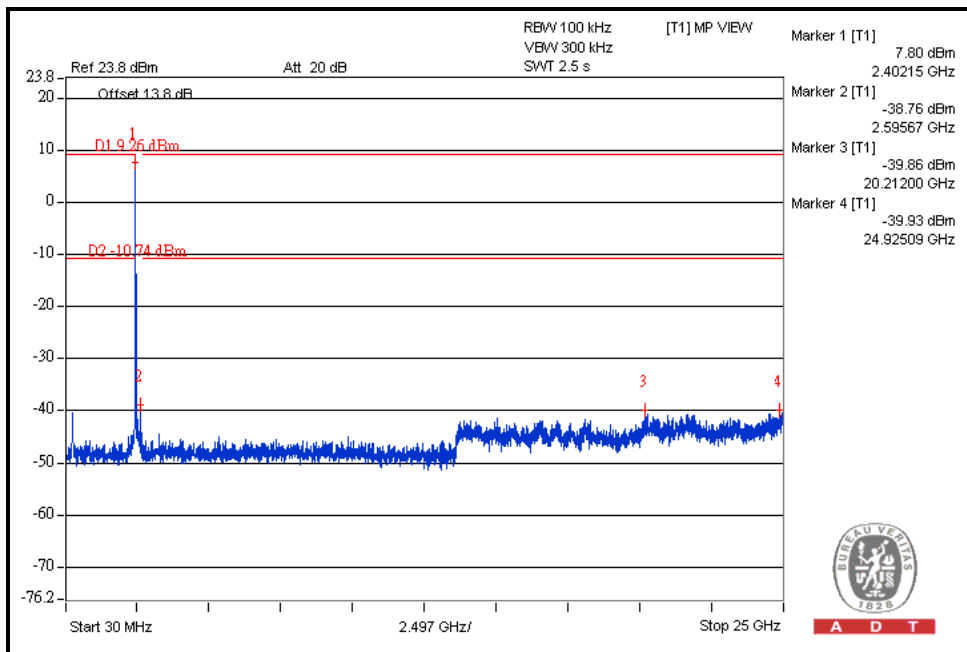
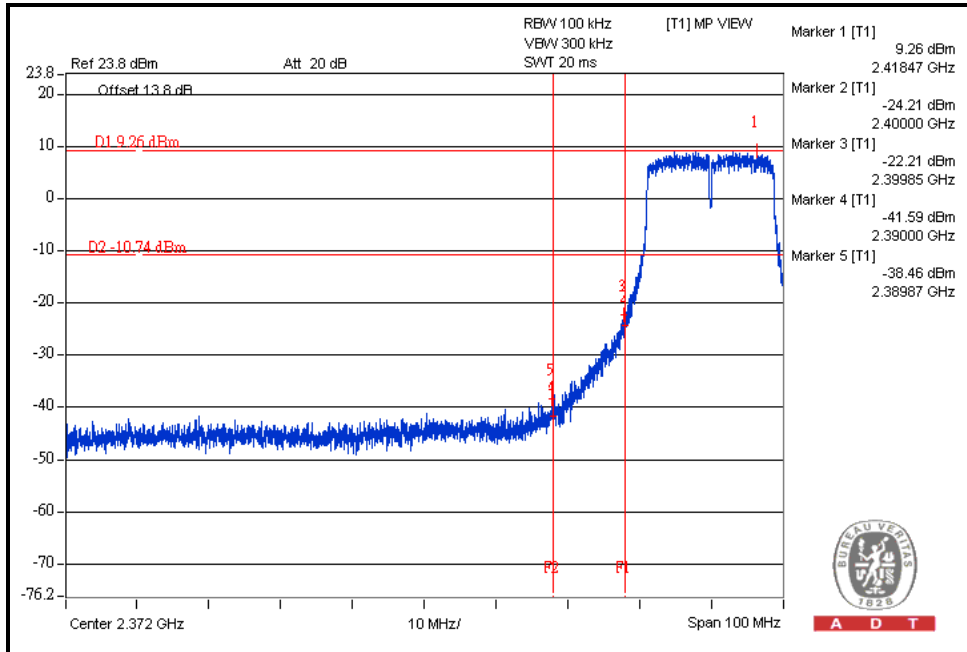



A D T

CH11

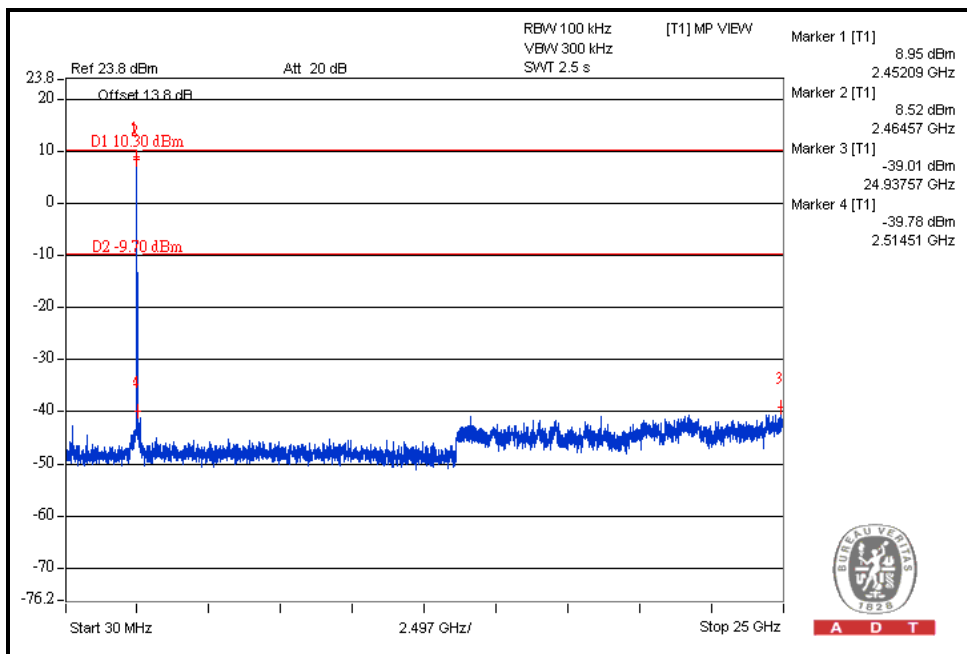
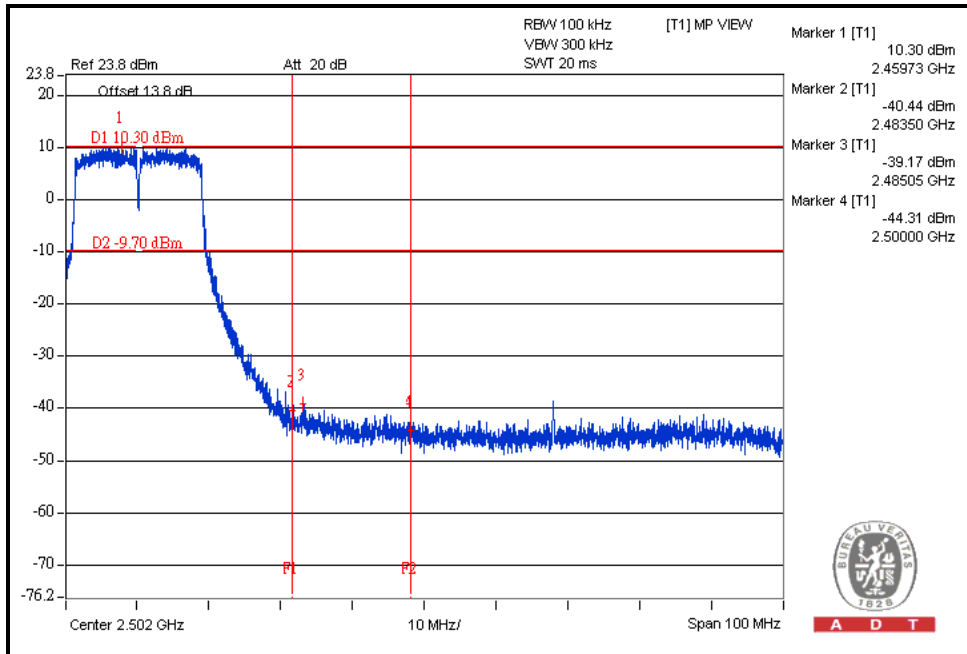



A D T

802.11n (40MHz) OFDM MODULATION:

CH3

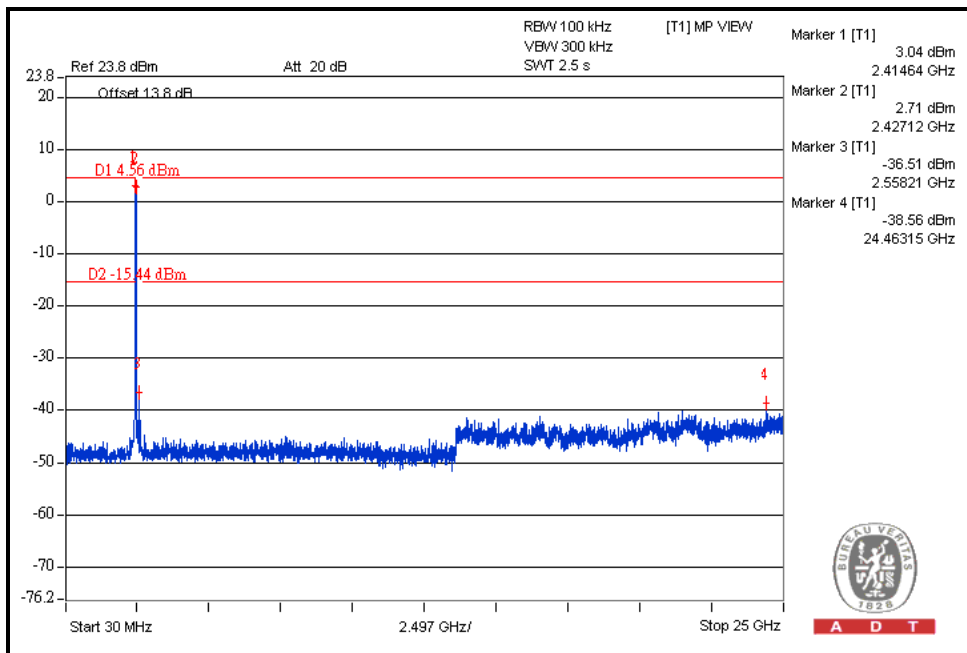
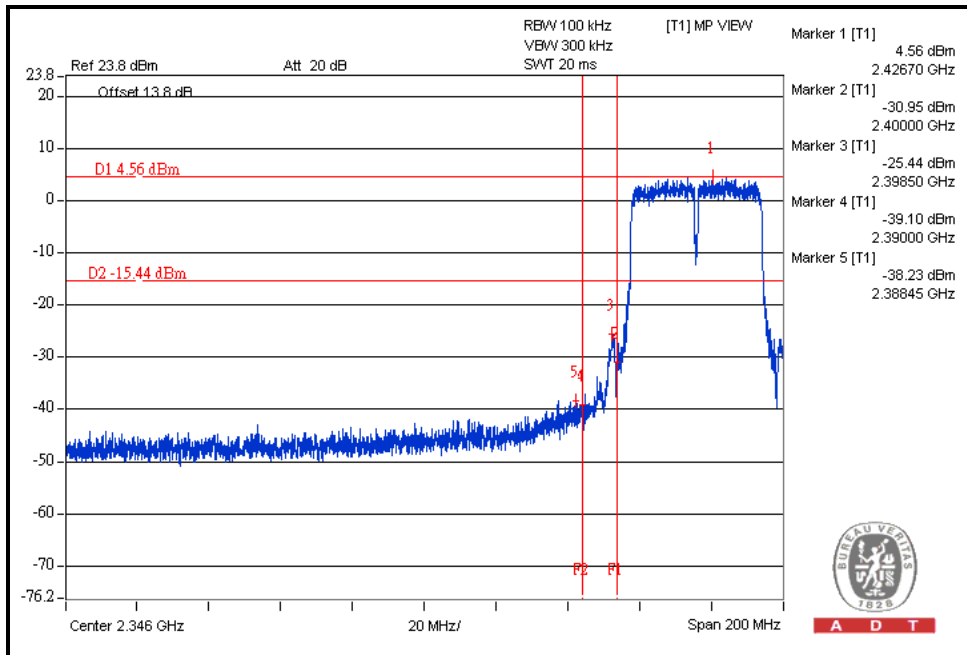



A D T

CH9

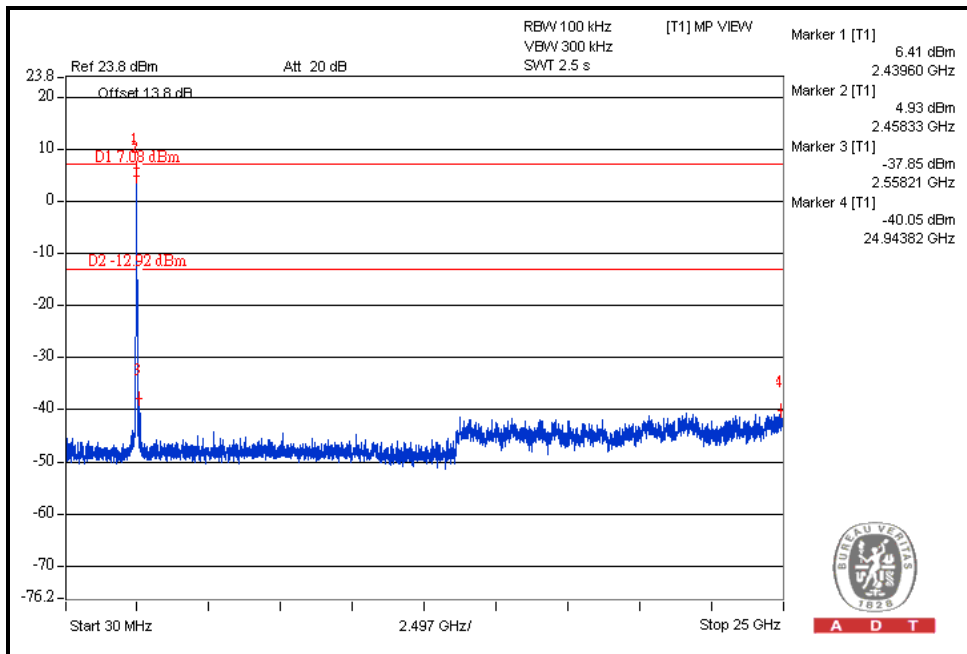
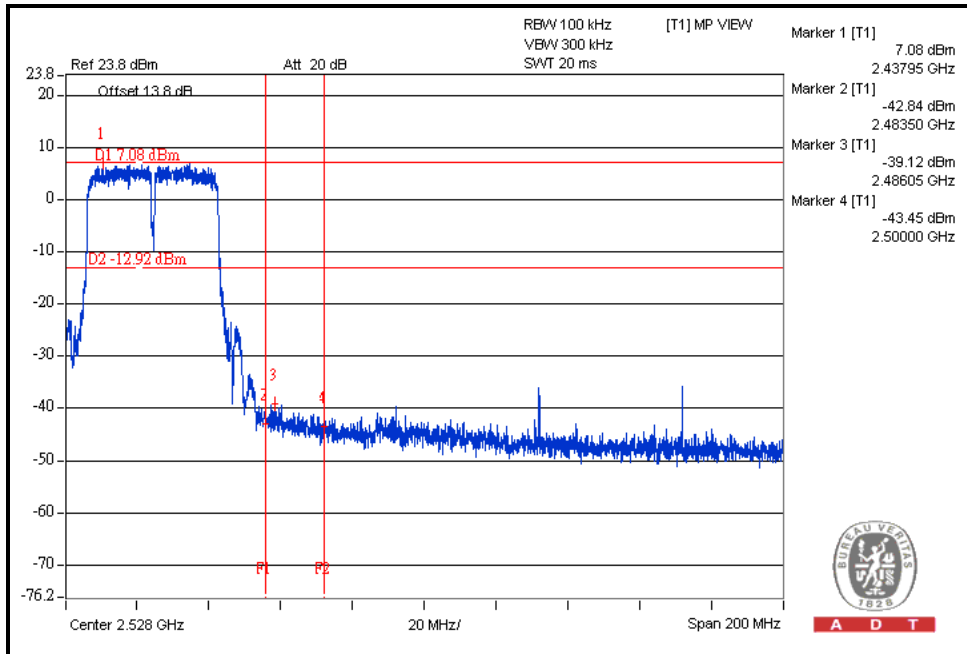



5. INFORMATION ON THE TESTING LABORATORIES

We, Bureau Veritas Consumer Products Services (H.K.) Ltd., Taoyuan Branch, were founded in 1988 to provide our best service in EMC, Radio, Telecom and Safety consultation. Our laboratories are accredited and approved according to ISO/IEC 17025.

Copies of accreditation and authorization certificates of our laboratories obtained from approval agencies can be downloaded from our web site:

www.adt.com.tw/index.5.phtml.

If you have any comments, please feel free to contact us at the following:

Linko EMC/RF Lab:

Tel: 886-2-26052180

Fax: 886-2-26052943

Hsin Chu EMC/RF Lab:

Tel: 886-3-5935343

Fax: 886-3-5935342

Hwa Ya EMC/RF/Safety/Telecom Lab:

Tel: 886-3-3183232

Fax: 886-3-3185050

Email: service.adt@tw.bureauveritas.com

Web Site: www.adt.com.tw

The address and road map of all our labs can be found in our web site also.



A D T

6.APPENDIX A - MODIFICATIONS RECORDERS FOR ENGINEERING CHANGES TO THE EUT BY THE LAB

No modifications were made to the EUT by the lab during the test.

--- END ---