



# FCC TEST REPORT

**REPORT NO.:** RF921002R05

**MODEL NO.:** DWL-G810 / DWL-G800AP

**BRAND:** D-Link

**RECEIVED:** October 01, 2003

**TESTED:** Oct. 01, 2003 ~ Oct. 06, 2003

**APPLICANT:** D-Link Corporation

**ADDRESS:** No. 8, Li-Hsin VII Road Science Based  
Industrial Park, Hsin-Chu, Taiwan

**ISSUED BY:** Advance Data Technology Corporation

**LAB LOCATION:** 47 14th Lin, Chiapau Tsun, Linko, Taipei,  
Taiwan, R.O.C.

This test report consists of 63 pages in total. It may be duplicated completely for legal use with the approval of the applicant. It should not be reproduced except in full, without the written approval of our laboratory. The client should not use it to claim product endorsement by CNLA, NVLAP or any government agencies. The test results in the report only apply to the tested sample.



0528  
ILAC MRA



Lab Code: 200102-0



## Table of Contents

1	CERTIFICATION .....	4
2	SUMMARY OF TEST RESULTS .....	5
3	GENERAL INFORMATION .....	6
3.1	GENERAL DESCRIPTION OF EUT .....	6
3.2	DESCRIPTION OF TEST MODES .....	7
3.3	GENERAL DESCRIPTION OF APPLIED STANDARDS .....	7
3.4	DESCRIPTION OF SUPPORT UNITS .....	8
3.5	CONFIGURATION OF SYSTEM UNDER TEST .....	8
4	TEST TYPES AND RESULTS .....	9
4.1	CONDUCTED EMISSION MEASUREMENT .....	9
4.1.1	LIMITS OF CONDUCTED EMISSION MEASUREMENT .....	9
4.1.2	TEST INSTRUMENTS .....	9
4.1.3	TEST PROCEDURES .....	10
4.1.4	DEVIATION FROM TEST STANDARD .....	10
4.1.5	TEST SETUP .....	11
4.1.6	EUT OPERATING CONDITIONS .....	11
4.1.7	TEST RESULTS .....	12
4.2	RADIATED EMISSION MEASUREMENT .....	18
4.2.1	LIMITS OF RADIATED EMISSION MEASUREMENT .....	18
4.2.2	TEST INSTRUMENTS .....	19
4.2.3	TEST PROCEDURES .....	20
4.2.4	DEVIATION FROM TEST STANDARD .....	20
4.2.5	TEST SETUP .....	21
4.2.6	EUT OPERATING CONDITIONS .....	21
4.2.7	TEST RESULTS .....	22
4.2.8	TEST RESULTS (FOR CCK) .....	24
4.2.9	TEST RESULTS (FOR OFDM) .....	27
4.3	6dB BANDWIDTH MEASUREMENT .....	30
4.3.1	LIMITS OF 6dB BANDWIDTH MEASUREMENT .....	30
4.3.2	TEST INSTRUMENTS .....	30
4.3.3	TEST PROCEDURE .....	31
4.3.4	DEVIATION FROM TEST STANDARD .....	31
4.3.5	TEST SETUP .....	31
4.3.6	EUT OPERATING CONDITIONS .....	31
4.3.7	TEST RESULTS .....	32
4.4	MAXIMUM PEAK OUTPUT POWER .....	40



4.4.1	LIMITS OF MAXIMUM PEAK OUTPUT POWER MEASUREMENT .....	40
4.4.2	TEST INSTRUMENTS .....	40
4.4.3	TEST PROCEDURES .....	41
4.4.4	DEVIATION FROM TEST STANDARD .....	41
4.4.5	TEST SETUP .....	41
4.4.6	EUT OPERATING CONDITIONS .....	41
4.4.7	TEST RESULTS .....	42
4.5	POWER SPECTRAL DENSITY MEASUREMENT .....	43
4.5.1	LIMITS OF POWER SPECTRAL DENSITY MEASUREMENT .....	43
4.5.2	TEST INSTRUMENTS .....	43
4.5.3	TEST PROCEDURE .....	44
4.5.4	DEVIATION FROM TEST STANDARD .....	44
4.5.5	TEST SETUP .....	44
4.5.6	EUT OPERATING CONDITIONS .....	44
4.5.7	TEST RESULTS .....	45
4.6	BAND EDGES MEASUREMENT .....	53
4.6.1	LIMITS OF BAND EDGES MEASUREMENT .....	53
4.6.2	TEST INSTRUMENTS .....	53
4.6.3	TEST PROCEDURE .....	53
4.6.4	DEVIATION FROM TEST STANDARD .....	53
4.6.5	EUT OPERATING CONDITION .....	54
4.6.6	TEST RESULTS ( FOR CCK) .....	54
4.6.7	TEST RESULTS ( FOR OFDM) .....	57
4.7	ANTENNA REQUIREMENT .....	60
4.7.1	STANDARD APPLICABLE .....	60
4.7.2	ANTENNA CONNECTED CONSTRUCTION .....	60
5	PHOTOGRAPHS OF THE TEST CONFIGURATION .....	61
6	INFORMATION ON THE TESTING LABORATORIES .....	63



# 1 CERTIFICATION

**PRODUCT :** 802.11g High-Speed Ethernet to Wireless Bridge  
**MODEL NO.:** DWL-G810 / DWL-G800AP  
**BRAND:** D-Link  
**APPLICANT :** D-Link Corporation  
**TEST ITEM:** Engineering Sample  
**STANDARDS :** 47 CFR Part 15, Subpart C (Section 15.247),  
ANSI C63.4-1992

We, **Advance Data Technology Corporation**, hereby certify that one sample of the designation has been tested in our facility from Oct. 01, 2003 ~ Oct. 06, 2003. The test record, data evaluation and Equipment Under Test (EUT) configurations represented herein are true and accurate accounts of the measurements of the sample's EMC characteristics under the conditions herein specified.

PREPARED BY: Wendy Liao , DATE: October 08, 2003  
Wendy Liao  
APPROVED BY: Ellis Wu , DATE: October 08, 2003  
Ellis Wu / Manager



## 2 SUMMARY OF TEST RESULTS

The EUT has been tested according to the following specifications:

<b>APPLIED STANDARD: 47 CFR Part 15, Subpart C</b>			
<b>Standard Section</b>	<b>Test Type and Limit</b>	<b>Result</b>	<b>REMARK</b>
15.207	AC Power Conducted Emission	PASS	Meet the requirement of limit Minimum passing margin is -6.26dB at 0.248MHz
15.247(a)(2)	Spectrum Bandwidth of a Direct Sequence Spread Spectrum System Limit: min. 500kHz	PASS	Meet the requirement of limit
15.247(b)	Maximum Peak Output Power Limit: max. 30dBm	PASS	Meet the requirement of limit
15.247(c)	Transmitter Radiated Emissions Limit: Table 15.209	PASS	Meet the requirement of limit Minimum passing margin is -2.00dB at 2688.00MHz
15.247(d)	Power Spectral Density Limit: max. 8dBm	PASS	Meet the requirement of limit
15.247(c)	Band Edge Measurement Limit: 20 dB less than the peak value of fundamental frequency	PASS	Meet the requirement of limit



### 3 GENERAL INFORMATION

#### 3.1 GENERAL DESCRIPTION OF EUT

<b>PRODUCT</b>	802.11g High-Speed Ethernet to Wireless Bridge
<b>MODEL NO.</b>	DWL-G810 / DWL-G800AP
<b>BRAND</b>	D-Link
<b>POWER SUPPLY</b>	5VDC from power adapter
<b>MODULATION TYPE</b>	BPSK, QPSK, CCK, 16QAM, 64QAM
<b>RADIO TECHNOLOGY</b>	DSSS, OFDM
<b>TRANSFER RATE</b>	Up to 54Mbps
<b>FREQUENCY RANGE</b>	2412MHz ~ 2462MHz
<b>NUMBER OF CHANNEL</b>	11
<b>OUTPUT POWER</b>	17.12dBm
<b>ANTENNA TYPE</b>	Dipole antenna with 1.8dBi gain
<b>DATA CABLE</b>	NA
<b>I/O PORTS</b>	RJ45 Port
<b>ASSOCIATED DEVICES</b>	NA

**NOTE:**

1. The following adapter is provided to this EUT:

<b>BRAND:</b>	D-Link
<b>MODEL:</b>	SMP-T1378
<b>INPUT:</b>	100-120V--0.5A 50-60Hz
<b>OUTPUT:</b>	5V--2.0A

2. The EUT operates in the 2.4GHz frequency spectrum with throughput of up to 54Mbps.
3. The EUT complies with IEEE 802.11g draft standards, and backwards compatible with IEEE 802.11b products.
4. For more detailed features description, please refer to the manufacturer's specifications or User's Manual.



### 3.2 DESCRIPTION OF TEST MODES

Eleven channels are provided to this EUT.

Channel	Frequency	Channel	Frequency
1	2412 MHz	7	2442 MHz
2	2417 MHz	8	2447 MHz
3	2422 MHz	9	2452 MHz
4	2427 MHz	10	2457 MHz
5	2432 MHz	11	2462 MHz
6	2437 MHz		

**NOTE:**

1. Below 1GHz, the channel 1, 6, and 11 were pre-tested in chamber. The channel 11, worst case one, was chosen for final test.
2. Above 1GHz, the channel 1, 6, and 11 were tested individually.
3. Transfer rate, 11Mbps with CCK technique and 6Mbps with OFDM technique, the worst case, were chosen for final test.

### 3.3 GENERAL DESCRIPTION OF APPLIED STANDARDS

The EUT is the specifications of the manufacturer, it must comply with the requirements of the following standards:

**FCC 47 CFR Part 15, Subpart C. (15.247)**

**ANSI C63.4: 1992**

All test items have been performed and recorded as per the above standards.

**NOTE:** The EUT is also considered as a kind of computer peripheral, because the connection to computer is necessary for typical use. It has been verified to comply with the requirements of FCC Part 15, Subpart B, Class B (DoC). The test report has been issued separately.



### 3.4 DESCRIPTION OF SUPPORT UNITS

The EUT has been tested as an independent unit together with other necessary accessories or support units. The following support units or accessories were used to form a representative test configuration during the tests.

NO.	PRODUCT	BRAND	MODEL NO.	SERIAL NO.	FCC ID
1	Notebook	Dell	PP01L	TW-09C748-12800-16M-5064	FCC DoC Approved
2	USB 10/100 Fast Ethernet	D-Link	DU-E100	UR15001597	FCC DoC Approved

NO.	SIGNAL CABLE DESCRIPTION OF THE ABOVE SUPPORT UNITS
1	NA
2	NA

**NOTE:** All power cords of the above support units are non shielded (1.8m).

### 3.5 CONFIGURATION OF SYSTEM UNDER TEST

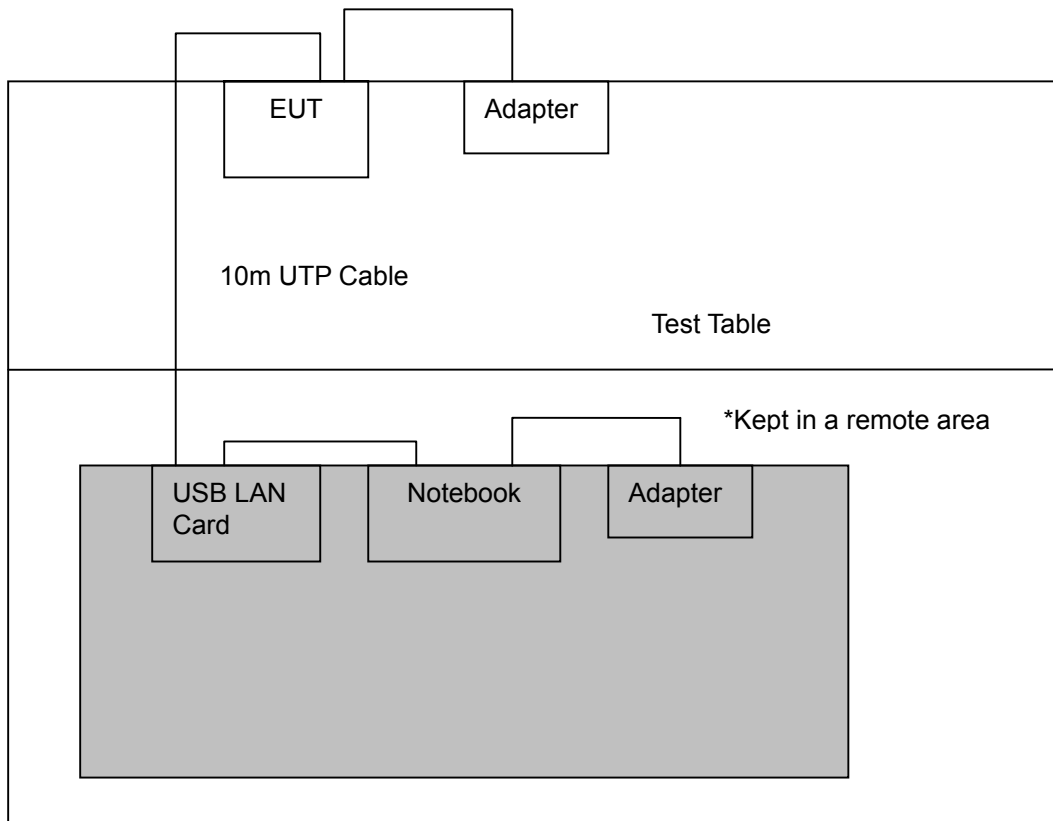





## 4 TEST TYPES AND RESULTS

### 4.1 CONDUCTED EMISSION MEASUREMENT

#### 4.1.1 LIMITS OF CONDUCTED EMISSION MEASUREMENT

FREQUENCY OF EMISSION (MHz)	CONDUCTED LIMIT (dB $\mu$ V)	
	Quasi-peak	Average
0.15-0.5	66 to 56	56 to 46
0.5-5	56	46
5-30	60	50

- NOTE:**
1. The lower limit shall apply at the transition frequencies.
  2. The limit decreases in line with the logarithm of the frequency in the range of 0.15 to 0.50 MHz.
  3. All emanations from a class A/B digital device or system, including any network of conductors and apparatus connected thereto, shall not exceed the level of field strengths specified above.

#### 4.1.2 TEST INSTRUMENTS

DESCRIPTION & MANUFACTURER	MODEL NO.	SERIAL NO.	CALIBRATED UNTIL
ROHDE & SCHWARZ Test Receiver	ESCS 30	838251/021	Jan. 20, 2004
ROHDE & SCHWARZ Artificial Mains Network (for EUT)	ESH3-Z5	100218	Dec. 18, 2003
ROHDE & SCHWARZ Artificial Mains Network (for peripherals)	ESH3-Z5	100219	Dec. 18, 2003
ROHDE & SCHWARZ Artificial Mains Network (for peripherals)	ESH3-Z5	100220	Dec. 18, 2003
ROHDE & SCHWARZ 4-wire ISN	ENY41	837032/016	Nov. 29, 2003
ROHDE & SCHWARZ 2-wire ISN	ENY22	837497/016	Nov. 29, 2003
Software	Cond-V2M3	NA	NA
RF cable (JYEBAO)	5D-FB	Cable-C10.01	May 01, 2004
SUHNER Terminator (For ROHDE & SCHWARZ LISN)	65BNC-5001	E1-010770	Mar. 24, 2004
SUHNER Terminator (For ROHDE & SCHWARZ LISN)	65BNC-5001	E1-010773	Apr. 06, 2004

- NOTE:**
1. The calibration interval of the above test instruments is 12 months and the calibrations are traceable to NML/ROC and NIST/USA.
  2. “\*”: These equipment are used for conducted telecom port test only (if tested).
  3. The test was performed in ADT Shielded Room No. 10.
  4. The VCCI Site Registration No. is C-1312.



#### 4.1.3 TEST PROCEDURES

- a. The EUT was placed 0.4 meters from the conducting wall of the shielded room with EUT being connected to the power mains through a line impedance stabilization network (LISN). Other support units were connected to the power mains through another LISN. The two LISNs provide 50 ohm/ 50uH of coupling impedance for the measuring instrument.
- b. Both lines of the power mains connected to the EUT were checked for maximum conducted interference.
- c. The frequency range from 150kHz to 30MHz was searched. Emission levels over 10dB under the prescribed limits could not be reported

#### 4.1.4 DEVIATION FROM TEST STANDARD

No deviation

#### 4.1.5 TEST SETUP

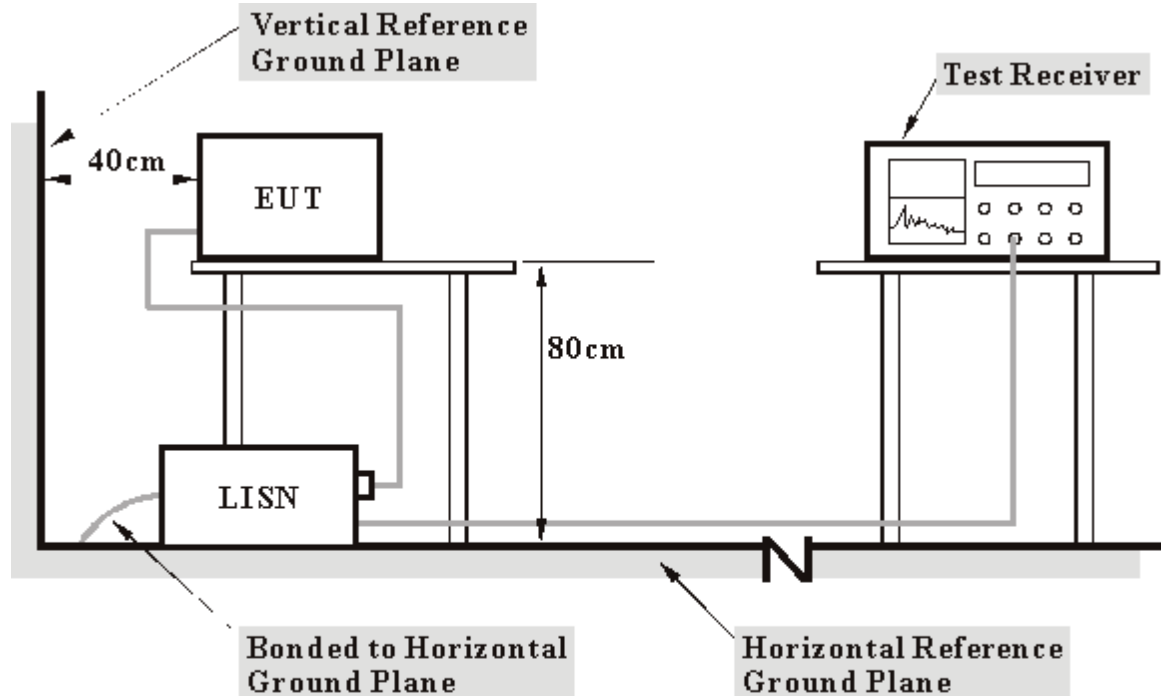

- Note:**
1. Support units were connected to second LISN.
  2. Both of LISNs (AMN) 80 cm from EUT and at the least 80 cm from other units and other metal planes support units.

For the actual test configuration, please refer to the related item – Photographs of the Test Configuration.

#### 4.1.6 EUT OPERATING CONDITIONS

- a. Placed the EUT on the testing table.
- b. Prepared another computer system to act as a communication partner and placed it outside of testing area.
- c. The communication partner run a test program to enable EUT under transmission/receiving condition continuously at specific channel frequency via an RJ45 cable.
- d. The communication partner sent data to EUT by command "PIN".



4.1.7 TEST RESULTS

<b>EUT</b>	802.11g High-Speed Ethernet to Wireless Bridge	<b>MODEL</b>	DWL-G810 DWL-G800AP
<b>MODE</b>	Channel 1	<b>6dB BANDWIDTH</b>	9kHz
<b>INPUT POWER (SYSTEM)</b>	120Vac, 60 Hz	<b>PHASE</b>	Line (L)
<b>ENVIRONMENTAL CONDITIONS</b>	25deg. C, 70%RH, 991hPa	<b>TESTED BY:</b> Martin Lee	

No	Freq. [MHz]	Corr. Factor (dB)	Reading Value		Emission Level		Limit		Margin	
			[dB (uV)]		[dB (uV)]		[dB (uV)]		(dB)	
			Q.P.	AV.	Q.P.	AV.	Q.P.	AV.	Q.P.	AV.
1	0.248	0.06	55.52	31.99	55.58	32.05	61.84	51.84	-6.26	-19.79
2	0.343	0.06	51.01	35.44	51.07	35.50	59.14	49.14	-8.07	-13.64
3	0.392	0.06	45.65	-	45.71	-	58.01	48.01	-12.30	-
4	0.436	0.07	43.28	-	43.35	-	57.14	47.14	-13.79	-
5	0.490	0.08	46.23	23.25	46.31	23.33	56.16	46.16	-9.85	-22.83
6	1.161	0.16	31.22	-	31.38	-	56.00	46.00	-24.62	-
7	8.395	0.36	36.63	-	36.99	-	60.00	50.00	-23.01	-
8	19.862	0.64	45.84	-	46.48	-	60.00	50.00	-13.52	-

- REMARKS:**
1. Q.P. and AV. are abbreviations of quasi-peak and average individually.
  2. "-": The Quasi-peak reading value also meets average limit and measurement with the average detector is unnecessary.
  3. The emission levels of other frequencies were very low against the limit.
  4. Margin value = Emission level - Limit value
  5. Correction factor = Insertion loss + Cable loss
  6. Emission Level = Correction Factor + Reading Value.

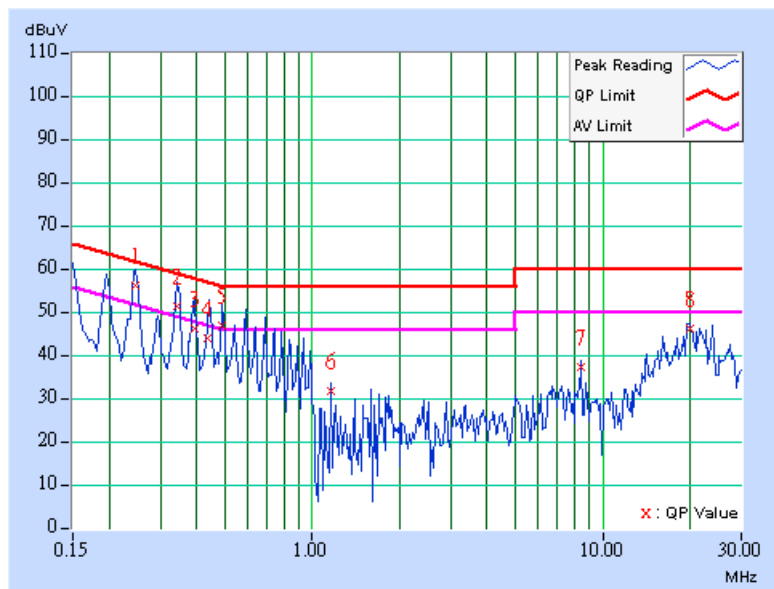



<b>EUT</b>	802.11g High-Speed Ethernet to Wireless Bridge	<b>MODEL</b>	DWL-G810 DWL-G800AP
<b>MODE</b>	Channel 1	<b>6dB BANDWIDTH</b>	9kHz
<b>INPUT POWER (SYSTEM)</b>	120Vac, 60 Hz	<b>PHASE</b>	Neutral (N)
<b>ENVIRONMENTAL CONDITIONS</b>	25deg. C, 70%RH, 991hPa	<b>TESTED BY:</b> Martin Lee	

No	Freq. [MHz]	Corr. Factor (dB)	Reading Value		Emission Level		Limit		Margin	
			[dB (uV)]		[dB (uV)]		[dB (uV)]		(dB)	
			Q.P.	AV.	Q.P.	AV.	Q.P.	AV.	Q.P.	AV.
1	0.197	0.05	49.85	-	49.90	-	63.74	53.74	-13.84	-
2	0.243	0.05	51.23	-	51.28	-	61.99	51.99	-10.71	-
3	0.484	0.06	34.68	-	34.74	-	56.27	46.27	-21.53	-
4	2.414	0.19	30.27	-	30.46	-	56.00	46.00	-25.54	-
5	7.243	0.31	34.90	-	35.21	-	60.00	50.00	-24.79	-
6	19.645	0.51	34.36	-	34.87	-	60.00	50.00	-25.13	-

- REMARKS:**
1. Q.P. and AV. are abbreviations of quasi-peak and average individually.
  2. "-": The Quasi-peak reading value also meets average limit and measurement with the average detector is unnecessary.
  3. The emission levels of other frequencies were very low against the limit.
  4. Margin value = Emission level - Limit value
  5. Correction factor = Insertion loss + Cable loss
  6. Emission Level = Correction Factor + Reading Value.

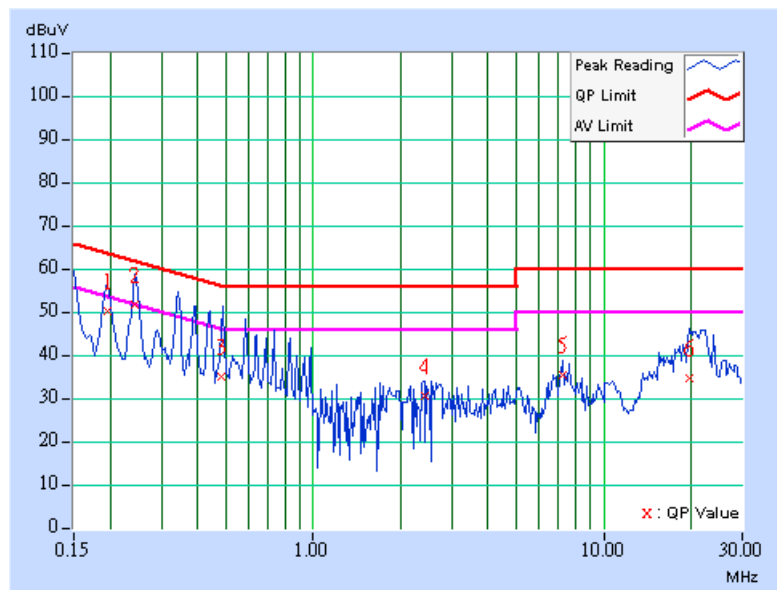



<b>EUT</b>	802.11g High-Speed Ethernet to Wireless Bridge	<b>MODEL</b>	DWL-G810 DWL-G800AP
<b>MODE</b>	Channel 6	<b>6dB BANDWIDTH</b>	9kHz
<b>INPUT POWER (SYSTEM)</b>	120Vac, 60 Hz	<b>PHASE</b>	Line (L)
<b>ENVIRONMENTAL CONDITIONS</b>	25deg. C, 70%RH, 991hPa	<b>TESTED BY:</b> Martin Lee	

No	Freq. [MHz]	Corr. Factor (dB)	Reading Value		Emission Level		Limit		Margin	
			[dB (uV)]		[dB (uV)]		[dB (uV)]		(dB)	
			Q.P.	AV.	Q.P.	AV.	Q.P.	AV.	Q.P.	AV.
1	0.244	0.06	49.55	-	49.61	-	61.97	51.97	-12.36	-
2	0.338	0.06	43.86	-	43.92	-	59.25	49.25	-15.33	-
3	0.338	0.06	43.78	-	43.84	-	59.25	49.25	-15.41	-
4	0.965	0.15	26.31	-	26.46	-	56.00	46.00	-29.54	-
5	8.756	0.37	38.26	-	38.63	-	60.00	50.00	-21.37	-
6	19.861	0.64	44.56	-	45.20	-	60.00	50.00	-14.80	-

- REMARKS:**
1. Q.P. and AV. are abbreviations of quasi-peak and average individually.
  2. "-": The Quasi-peak reading value also meets average limit and measurement with the average detector is unnecessary.
  3. The emission levels of other frequencies were very low against the limit.
  4. Margin value = Emission level - Limit value
  5. Correction factor = Insertion loss + Cable loss
  6. Emission Level = Correction Factor + Reading Value.

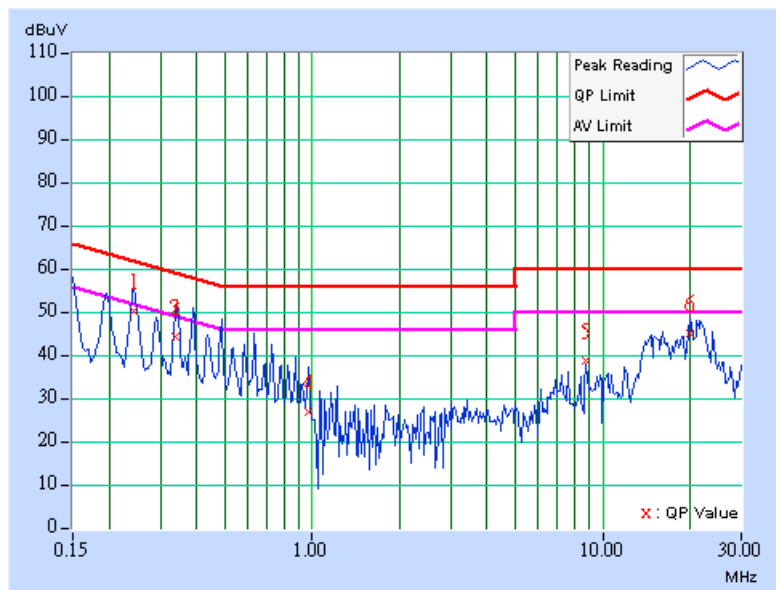



<b>EUT</b>	802.11g High-Speed Ethernet to Wireless Bridge	<b>MODEL</b>	DWL-G810 DWL-G800AP
<b>MODE</b>	Channel 6	<b>6dB BANDWIDTH</b>	9kHz
<b>INPUT POWER (SYSTEM)</b>	120Vac, 60 Hz	<b>PHASE</b>	Neutral (N)
<b>ENVIRONMENTAL CONDITIONS</b>	25deg. C, 70%RH, 991hPa	<b>TESTED BY:</b> Martin Lee	

No	Freq. [MHz]	Corr. Factor (dB)	Reading Value		Emission Level		Limit		Margin	
			[dB (uV)]		[dB (uV)]		[dB (uV)]		(dB)	
			Q.P.	AV.	Q.P.	AV.	Q.P.	AV.	Q.P.	AV.
1	0.244	0.05	50.62	-	50.67	-	61.97	51.97	-11.30	-
2	0.385	0.05	39.42	-	39.47	-	58.17	48.17	-18.70	-
3	0.482	0.06	38.34	-	38.40	-	56.30	46.30	-17.90	-
4	1.352	0.17	30.42	-	30.59	-	56.00	46.00	-25.41	-
5	2.749	0.19	31.64	-	31.83	-	56.00	46.00	-24.17	-
6	21.238	0.56	40.38	-	40.94	-	60.00	50.00	-19.06	-

- REMARKS:**
1. Q.P. and AV. are abbreviations of quasi-peak and average individually.
  2. "-": The Quasi-peak reading value also meets average limit and measurement with the average detector is unnecessary.
  3. The emission levels of other frequencies were very low against the limit.
  4. Margin value = Emission level - Limit value
  5. Correction factor = Insertion loss + Cable loss
  6. Emission Level = Correction Factor + Reading Value.

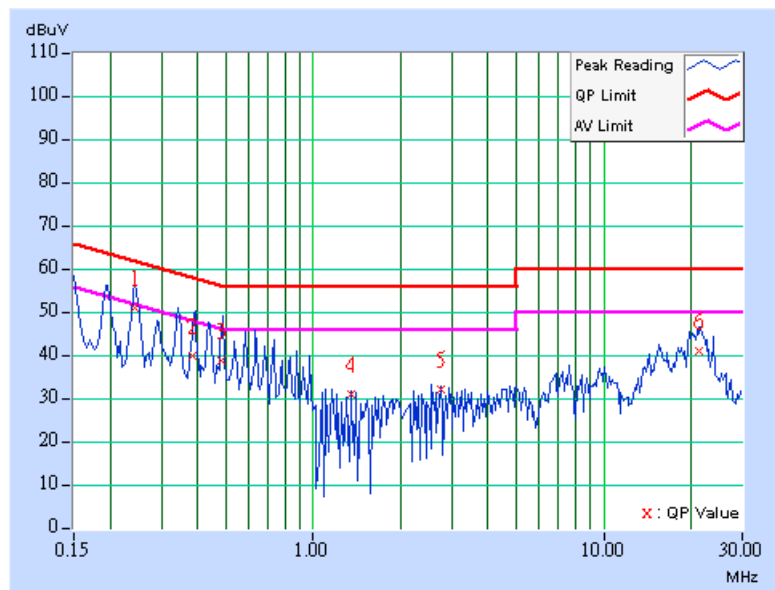



<b>EUT</b>	802.11g High-Speed Ethernet to Wireless Bridge	<b>MODEL</b>	DWL-G810 DWL-G800AP
<b>MODE</b>	Channel 11	<b>6dB BANDWIDTH</b>	9kHz
<b>INPUT POWER (SYSTEM)</b>	120Vac, 60 Hz	<b>PHASE</b>	Line (L)
<b>ENVIRONMENTAL CONDITIONS</b>	25eg. C, 70%RH, 991hPa	<b>TESTED BY:</b> Martin Lee	

No	Freq. [MHz]	Corr. Factor (dB)	Reading Value		Emission Level		Limit		Margin	
			[dB (uV)]		[dB (uV)]		[dB (uV)]		(dB)	
			Q.P.	AV.	Q.P.	AV.	Q.P.	AV.	Q.P.	AV.
1	0.150	0.05	57.47	41.95	57.52	42.00	66.00	56.00	-8.48	-14.00
2	0.244	0.06	54.63	35.30	54.69	35.36	61.97	51.97	-7.28	-16.61
3	0.345	0.06	50.46	26.78	50.52	26.84	59.07	49.07	-8.55	-22.23
4	0.590	0.09	43.36	-	43.45	-	56.00	46.00	-12.55	-
5	0.982	0.16	34.78	-	34.94	-	56.00	46.00	-21.06	-
6	4.586	0.24	30.64	-	30.88	-	56.00	46.00	-25.12	-
7	8.403	0.36	38.65	-	39.01	-	60.00	50.00	-20.99	-
8	22.211	0.75	37.75	-	38.50	-	60.00	50.00	-21.50	-

- REMARKS:**
1. Q.P. and AV. are abbreviations of quasi-peak and average individually.
  2. "-": The Quasi-peak reading value also meets average limit and measurement with the average detector is unnecessary.
  3. The emission levels of other frequencies were very low against the limit.
  4. Margin value = Emission level - Limit value
  5. Correction factor = Insertion loss + Cable loss
  6. Emission Level = Correction Factor + Reading Value.

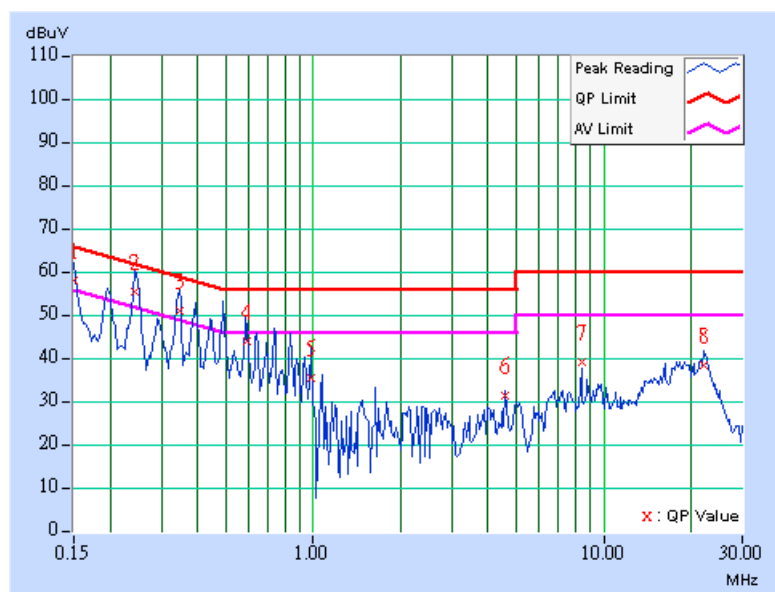





<b>EUT</b>	802.11g High-Speed Ethernet to Wireless Bridge	<b>MODEL</b>	DWL-G810 DWL-G800AP
<b>MODE</b>	Channel 11	<b>6dB BANDWIDTH</b>	9kHz
<b>INPUT POWER (SYSTEM)</b>	120Vac, 60 Hz	<b>PHASE</b>	Neutral (N)
<b>ENVIRONMENTAL CONDITIONS</b>	25deg. C, 70%RH, 991hPa	<b>TESTED BY:</b> Martin Lee	

No	Freq. [MHz]	Corr. Factor (dB)	Reading Value		Emission Level		Limit		Margin	
			[dB (uV)]		[dB (uV)]		[dB (uV)]		(dB)	
			Q.P.	AV.	Q.P.	AV.	Q.P.	AV.	Q.P.	AV.
1	0.150	0.05	56.27	40.27	56.32	40.32	66.00	56.00	-9.68	-15.68
2	0.244	0.05	54.40	35.89	54.45	35.94	61.97	51.97	-7.52	-16.03
3	0.345	0.05	49.20	26.20	49.25	26.25	59.09	49.09	-9.84	-22.84
4	0.492	0.07	45.54	-	45.61	-	56.14	46.14	-10.53	-
5	0.734	0.11	40.24	-	40.35	-	56.00	46.00	-15.65	-
6	4.441	0.22	30.76	-	30.98	-	56.00	46.00	-25.02	-
7	7.289	0.31	33.48	-	33.79	-	60.00	50.00	-26.21	-
8	22.883	0.64	34.04	-	34.68	-	60.00	50.00	-25.32	-

- REMARKS:**
1. Q.P. and AV. are abbreviations of quasi-peak and average individually.
  2. "-": The Quasi-peak reading value also meets average limit and measurement with the average detector is unnecessary.
  3. The emission levels of other frequencies were very low against the limit.
  4. Margin value = Emission level - Limit value
  5. Correction factor = Insertion loss + Cable loss
  6. Emission Level = Correction Factor + Reading Value.

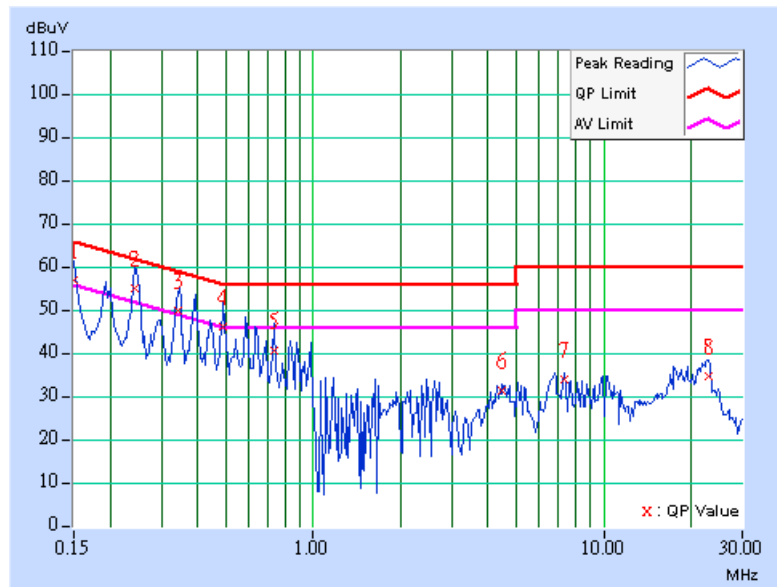



**4.2 RADIATED EMISSION MEASUREMENT**

**4.2.1 LIMITS OF RADIATED EMISSION MEASUREMENT**

Emissions radiated outside of the specified bands, shall be according to the general radiated limits in 15.209 as following:

<b>Frequencies (MHz)</b>	<b>Field strength (microvolts/meter)</b>	<b>Measurement distance (meters)</b>
0.009-0.490	2400/F(kHz)	300
0.490-1.705	24000/F(kHz)	30
1.705-30.0	30	30
30-88	100	3
88-216	150	3
216-960	200	3
Above 960	500	3

**NOTE:**

1. The lower limit shall apply at the transition frequencies.
2. Emission level (dBuV/m) = 20 log Emission level (uV/m).
3. As shown in 15.35(b), for frequencies above 1000MHz, the field strength limits are based on average detector, however, the peak field strength of any emission shall not exceed the maximum permitted average limits, specified above by more than 20dB under any condition of modulation.



#### 4.2.2 TEST INSTRUMENTS

DESCRIPTION & MANUFACTURER	MODEL NO.	SERIAL NO.	CALIBRATED UNTIL
* HP Spectrum Analyzer	8594E	3911A07465	Jul. 07, 2004
* HP Preamplifier	8447D	2944A10386	Aug. 12, 2004
* HP Preamplifier	8449B	3008A01201	Dec. 01, 2003
* HP Preamplifier	8449B	3008A01292	Aug. 11, 2004
SCHAFFNER Tunable Dipole Antenna	VHBA 9123	459	Nov. 22, 2003
SCHWARZBECK Tunable Dipole Antenna	UHA 9105	977	
SCHAFFNER TEST RECEIVER	SCR 3501	409	Jan. 26, 2004
* SCHAFFNER BILOG Antenna	CBL6111C	2727	Jul. 15, 2004
* SCHWARZBECK Horn Antenna	BBHA9120-D1	D130	Jun 30, 2004
* EMCO Horn Antenna	3115	9312-4192	Mar. 23 2004
* ADT. Turn Table	TT100	0201	NA
* ADT. Tower	AT100	0201	NA
* Software	ADT_Radiated_V 5.14	NA	NA
* ANRITSU RF Switches	MP59B	6100237246	Oct. 30, 2003
* TIMES RF cable	LMR-600	CABLE-ST10-01	Oct. 30, 2003

- NOTE:**
1. The calibration interval of the above test instruments is 12 months. And the calibrations are traceable to NML/ROC and NIST/USA.
  2. "\*" = These equipment are used for the final measurement.
  3. The horn antenna and HP preamplifier (model: 8449B) are used only for the measurement of emission frequency above 1GHz if tested.
  4. The test was performed in ADT Open Site No. 10.
  5. The VCCI Site Registration No. is R-1625.



#### 4.2.3 TEST PROCEDURES

- a. The EUT was placed on the top of a rotating table 0.8 meters above the ground at a 10 meter open area test site. The table was rotated 360 degrees to determine the position of the highest radiation.
- b. The EUT was set 3 meters away from the interference-receiving antenna, which was mounted on the top of a variable-height antenna tower.
- c. The antenna is a broadband antenna, and its height is varied from one meter to four meters above the ground to determine the maximum value of the field strength. Both horizontal and vertical polarizations of the antenna are set to make the measurement.
- d. For each suspected emission, the EUT was arranged to its worst case and then the antenna was tuned to heights from 1 meter to 4 meters and the rotatable table was turned from 0 degrees to 360 degrees to find the maximum reading.
- e. The test-receiver system was set to Peak Detect Function and Specified Bandwidth with Maximum Hold Mode.
- f. If the emission level of the EUT in peak mode was 10 dB lower than the limit specified, then testing could be stopped and the peak values of the EUT would be reported. Otherwise the emissions that did not have 10 dB margin would be re-tested one by one using peak, quasi-peak or average method as specified and then reported in a data sheet.

**NOTE:**

1. The resolution bandwidth and video bandwidth of test receiver/spectrum analyzer is 120kHz for Peak detection (PK) and Quasi-peak detection (QP) at frequency below 1GHz.
2. The resolution bandwidth and video bandwidth of test receiver/spectrum analyzer is 1 MHz for Peak detection at frequency above 1GHz.
3. The resolution bandwidth of test receiver/spectrum analyzer is 1 MHz and the video bandwidth is 300 Hz for Average detection (AV) at frequency above 1GHz.

#### 4.2.4 DEVIATION FROM TEST STANDARD

No deviation

#### 4.2.5 TEST SETUP

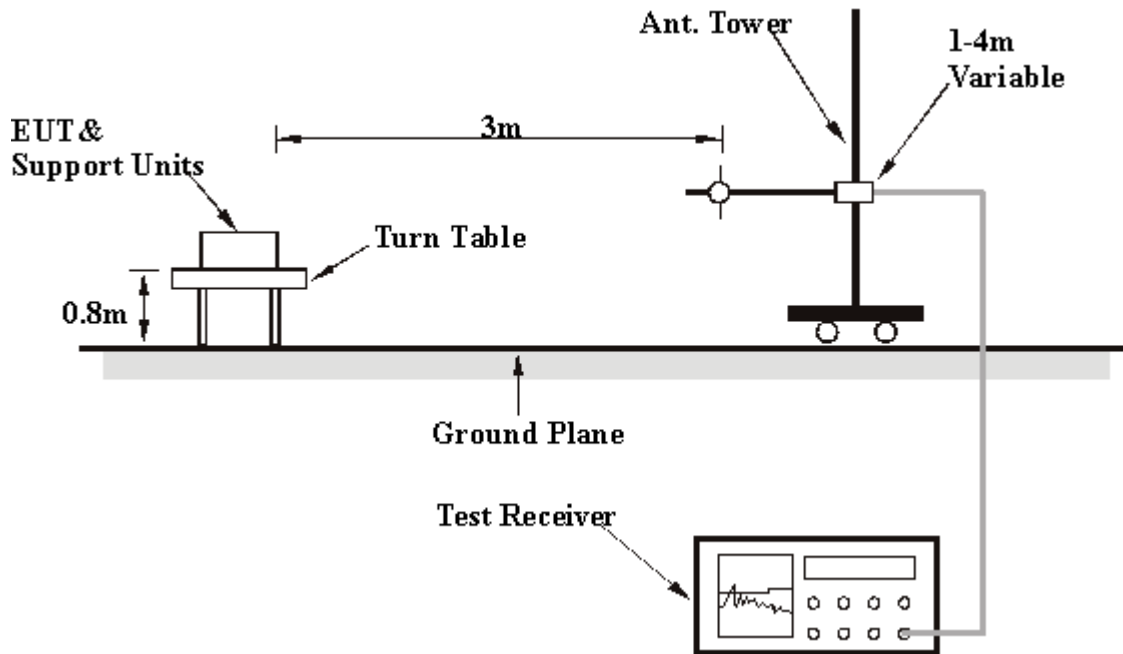

For the actual test configuration, please refer to the related item – Photographs of the Test Configuration.

#### 4.2.6 EUT OPERATING CONDITIONS

Same as 4.1.6



4.2.7 TEST RESULTS

<b>EUT</b>	802.11g High-Speed Ethernet to Wireless Bridge	<b>MODEL</b>	DWL-G810 DWL-G800AP
<b>MODE</b>	Channel 11	<b>FREQUENCY RANGE</b>	Below 1000MHz
<b>INPUT POWER (SYSTEM)</b>	120Vac, 60 Hz	<b>DETECTOR FUNCTION</b>	Quasi-Peak
<b>ENVIRONMENTAL CONDITIONS</b>	30deg. C, 60%RH, 991hPa	<b>TESTED BY:</b> Jamison Chan	

**ANTENNA POLARITY & TEST DISTANCE: HORIZONTAL AT 3 M**

No.	Freq. (MHz)	Emission Level (dBuV/m)	Limit (dBuV/m)	Margin (dB)	Antenna Height (m)	Table Angle (Degree)	Raw Value (dBuV)	Correction Factor (dB/m)
1	200.00	17.40 QP	43.50	-26.10	1.78 H	299	8.10	9.30
2	250.03	32.80 QP	46.00	-13.20	1.65 H	7	20.30	12.50
3	270.03	25.90 QP	46.00	-20.10	1.15 H	123	12.20	13.70
4	300.03	18.80 QP	46.00	-27.20	1.41 H	256	4.10	14.70
5	375.02	30.20 QP	46.00	-15.80	1.27 H	207	13.80	16.40
6	450.02	38.70 QP	46.00	-7.30	1.07 H	85	20.60	18.20
7	475.05	30.50 QP	46.00	-15.50	1.00 H	108	11.70	18.80
8	500.04	35.10 QP	46.00	-10.90	1.00 H	120	15.60	19.50
9	625.05	27.20 QP	46.00	-18.80	1.00 H	86	5.20	22.00
10	720.00	32.30 QP	46.00	-13.70	1.34 H	105	9.10	23.30
11	750.05	29.60 QP	46.00	-16.40	1.00 H	91	5.50	24.10
12	810.00	31.80 QP	46.00	-14.20	1.32 H	102	7.70	24.10
13	875.09	29.90 QP	46.00	-16.10	1.05 H	115	4.50	25.40

- REMARKS:**
1. Emission level(dBuV/m)=Raw Value(dBuV) + Correction Factor(dB/m)
  2. Correction Factor(dB/m) = Antenna Factor (dB/m) + Cable Factor (dB)
  3. The other emission levels were very low against the limit.
  4. Margin value = Emission level – Limit value.



<b>EUT</b>	802.11g High-Speed Ethernet to Wireless Bridge	<b>MODEL</b>	DWL-G810 DWL-G800AP
<b>MODE</b>	Channel 11	<b>FREQUENCY RANGE</b>	Below 1000MHz
<b>INPUT POWER (SYSTEM)</b>	120Vac, 60 Hz	<b>DETECTOR FUNCTION</b>	Quasi-Peak
<b>ENVIRONMENTAL CONDITIONS</b>	30deg. C, 60%RH, 991hPa	<b>TESTED BY:</b> Jamison Chan	

**ANTENNA POLARITY & TEST DISTANCE: VERTICAL AT 3 M**

No.	Freq. (MHz)	Emission Level (dBuV/m)	Limit (dBuV/m)	Margin (dB)	Antenna Height (m)	Table Angle (Degree)	Raw Value (dBuV)	Correction Factor (dB/m)
1	200.00	19.10 QP	43.50	-24.40	1.23 V	308	9.70	9.30
2	250.02	36.10 QP	46.00	-9.90	1.59 V	345	23.60	12.50
3	270.00	26.40 QP	46.00	-19.60	1.00 V	282	12.70	13.70
4	375.02	32.00 QP	46.00	-14.00	1.76 V	242	15.60	16.40
5	450.00	27.50 QP	46.00	-18.50	1.81 V	273	9.30	18.20
6	485.93	34.10 QP	46.00	-11.90	2.12 V	162	15.00	19.10
7	500.04	29.80 QP	46.00	-16.20	1.83 V	217	10.20	19.50
8	600.04	25.20 QP	46.00	-20.80	2.05 V	255	3.60	21.60
9	630.00	32.40 QP	46.00	-13.60	1.15 V	329	10.30	22.10
10	720.00	28.70 QP	46.00	-17.30	1.22 V	321	5.40	23.30
11	750.07	29.30 QP	46.00	-16.70	2.04 V	329	5.20	24.10
12	875.07	27.90 QP	46.00	-18.10	1.85 V	266	2.60	25.40

- REMARKS:**
1. Emission level(dBuV/m)=Raw Value(dBuV) + Correction Factor(dB/m)
  2. Correction Factor(dB/m) = Antenna Factor (dB/m) + Cable Factor (dB)
  3. The other emission levels were very low against the limit.
  4. Margin value = Emission level – Limit value.



4.2.8 TEST RESULTS (FOR CCK)

<b>EUT</b>	802.11g High-Speed Ethernet to Wireless Bridge	<b>MODEL</b>	DWL-G810 DWL-G800AP
<b>CHANNEL</b>	Channel 1	<b>FREQUENCY RANGE</b>	Above 1000MHz
<b>INPUT POWER (SYSTEM)</b>	120Vac, 60 Hz		
<b>ENVIRONMENTAL CONDITIONS</b>	30deg. C, 60%RH, 991hPa	<b>DETECTOR FUNCTION</b>	Peak(PK) Average (AV)
<b>TESTED BY:</b> Jamison Chan			

ANTENNA POLARITY & TEST DISTANCE: HORIZONTAL AT 3 M								
No.	Freq. (MHz)	Emission Level (dBuV/m)	Limit (dBuV/m)	Margin (dB)	Antenna Height (m)	Table Angle (Degree)	Raw Value (dBuV)	Correction Factor (dB/m)
1	2292.00	55.40 PK	74.00	-18.60	1.30 H	143	22.30	33.10
1	2292.00	49.90 AV	54.00	-4.10	1.30 H	143	16.80	33.10
2	*2412.00	102.70 PK			1.30 H	143	69.00	33.70
2	*2412.00	97.20 AV			1.30 H	143	63.50	33.70
3	4824.00	51.50 PK	74.00	-22.50	1.37 H	125	10.40	41.10
3	4824.00	40.00 AV	54.00	-14.00	1.37 H	125	-1.10	41.10
4	7326.00	55.90 PK	74.00	-18.10	1.39 H	142	10.60	45.30
4	7326.00	43.00 AV	54.00	-11.00	1.39 H	142	-2.20	45.30

ANTENNA POLARITY & TEST DISTANCE: VERTICAL AT 3 M								
No.	Freq. (MHz)	Emission Level (dBuV/m)	Limit (dBuV/m)	Margin (dB)	Antenna Height (m)	Table Angle (Degree)	Raw Value (dBuV)	Correction Factor (dB/m)
1	2292.00	54.50 PK	74.00	-19.50	1.00 V	240	21.40	33.10
1	2292.00	48.80 AV	54.00	-5.20	1.00 V	240	15.70	33.10
2	*2412.00	107.20 PK			1.00 V	240	73.50	33.70
2	*2412.00	101.50 AV			1.00 V	240	67.80	33.70
3	2688.00	53.70 PK	74.00	-20.30	1.00 V	240	19.00	34.70
3	2688.00	48.00 AV	54.00	-6.00	1.00 V	240	13.30	34.70
4	4824.00	53.00 PK	74.00	-21.00	1.00 V	219	11.90	41.10
4	4824.00	42.70 AV	54.00	-11.30	1.00 V	219	1.60	41.10
5	7236.00	56.30 PK	74.00	-17.70	1.30 V	10	11.50	44.80
5	7236.00	44.30 AV	54.00	-9.70	1.30 V	10	-0.50	44.80
6	9648.00	58.40 PK	74.00	-15.60	1.30 V	207	10.90	47.50
6	9648.00	45.80 AV	54.00	-8.20	1.30 V	207	-1.70	47.50

- REMARKS:**
1. Emission level(dBuV/m)=Raw Value(dBuV) + Correction Factor(dB)
  2. Correction Factor(dB/m) = Antenna Factor (dB/m) + Cable Factor (dB)
  3. The other emission levels were very low against the limit.
  4. Margin value = Emission level – Limit value.
  5. “ \* “ : Fundamental frequency.





<b>EUT</b>	802.11g High-Speed Ethernet to Wireless Bridge	<b>MODEL</b>	DWL-G810 DWL-G800AP
<b>CHANNEL</b>	Channel 6	<b>FREQUENCY RANGE</b>	Above 1000MHz
<b>INPUT POWER (SYSTEM)</b>	120Vac, 60 Hz		
<b>ENVIRONMENTAL CONDITIONS</b>	30deg. C, 60%RH, 991hPa	<b>DETECTOR FUNCTION</b>	Peak(PK) Average (AV)
<b>TESTED BY:</b> Jamison Chan			

<b>ANTENNA POLARITY &amp; TEST DISTANCE: HORIZONTAL AT 3M</b>								
No.	Freq. (MHz)	Emission Level (dBuV/m)	Limit (dBuV/m)	Margin (dB)	Antenna Height (m)	Table Angle (Degree)	Raw Value (dBuV)	Correction Factor (dB/m)
1	*2437.00	98.60 PK			1.28 H	153	64.80	33.80
1	*2437.00	96.30 AV			1.28 H	153	62.50	33.80
2	4874.00	46.00 PK	74.00	-28.00	1.25 H	263	4.70	41.30
3	7311.00	51.10 PK	74.00	-22.90	1.24 H	44	5.80	45.30
3	7311.00	43.90 AV	54.00	-10.10	1.24 H	44	-1.40	45.30

<b>ANTENNA POLARITY &amp; TEST DISTANCE: VERTICAL AT 3M</b>								
No.	Freq. (MHz)	Emission Level (dBuV/m)	Limit (dBuV/m)	Margin (dB)	Antenna Height (m)	Table Angle (Degree)	Raw Value (dBuV)	Correction Factor (dB/m)
1	*2437.00	104.10 PK			1.24 V	180	70.30	33.80
1	*2437.00	101.90 AV			1.24 V	180	68.20	33.80
2	4874.00	47.20 PK	74.00	-26.80	1.14 V	210	5.90	41.30
3	7311.00	50.90 PK	74.00	-23.10	1.14 V	222	5.60	45.30
4	9748.00	51.00 PK	74.00	-23.00	1.12 V	271	4.40	46.60
4	9748.00	45.20 AV	54.00	-8.80	1.12 V	271	-1.40	46.60

- REMARKS:**
1. Emission level(dBuV/m)=Raw Value(dBuV) + Correction Factor(dB)
  2. Correction Factor(dB/m) = Antenna Factor (dB/m) + Cable Factor (dB)
  3. The other emission levels were very low against the limit.
  4. Margin value = Emission level – Limit value.
  5. “ \* “ : Fundamental frequency.



<b>EUT</b>	802.11g High-Speed Ethernet to Wireless Bridge	<b>MODEL</b>	DWL-G810 DWL-G800AP
<b>CHANNEL</b>	Channel 11	<b>FREQUENCY RANGE</b>	Above 1000MHz
<b>INPUT POWER (SYSTEM)</b>	120Vac, 60 Hz		
<b>ENVIRONMENTAL CONDITIONS</b>	30deg. C, 60%RH, 991hPa	<b>DETECTOR FUNCTION</b>	Peak(PK) Average (AV)
<b>TESTED BY:</b> Jamison Chan			

<b>ANTENNA POLARITY &amp; TEST DISTANCE: HORIZONTAL AT 3M</b>								
No.	Freq. (MHz)	Emission Level (dBuV/m)	Limit (dBuV/m)	Margin (dB)	Antenna Height (m)	Table Angle (Degree)	Raw Value (dBuV)	Correction Factor (dB/m)
1	*2462.00	101.40 PK			1.30 H	147	67.50	33.90
1	*2462.00	96.00 AV			1.30 H	147	62.20	33.90
2	2483.50	54.00 PK	74.00	-20.00	1.30 H	147	20.10	33.90
2	2483.50	48.70 AV	54.00	-5.30	1.30 H	147	14.80	33.90
3	2688.00	54.90 PK	74.00	-19.10	1.30 H	147	20.20	34.70
3	2688.00	49.50 AV	54.00	-4.50	1.30 H	147	14.80	34.70
4	4924.00	52.60 PK	74.00	-21.40	1.35 H	158	11.20	41.40
4	4924.00	41.10 AV	54.00	-12.90	1.35 H	158	-0.30	41.40
5	7386.00	57.60 PK	74.00	-16.40	1.26 H	268	12.40	45.20
5	7386.00	44.60 AV	54.00	-9.40	1.26 H	268	-0.60	45.20

<b>ANTENNA POLARITY &amp; TEST DISTANCE: VERTICAL AT 3M</b>								
No.	Freq. (MHz)	Emission Level (dBuV/m)	Limit (dBuV/m)	Margin (dB)	Antenna Height (m)	Table Angle (Degree)	Raw Value (dBuV)	Correction Factor (dB/m)
1	*2462.00	104.00 PK			1.00 V	153	70.20	33.90
1	*2462.00	101.70 AV			1.00 V	153	67.80	33.90
2	2483.50	46.20 PK	74.00	-27.80	1.00 V	153	12.30	33.90
2	2483.50	43.90 AV	54.00	-10.10	1.00 V	153	10.00	33.90
3	2688.00	49.70 PK	74.00	-24.30	1.00 V	153	15.00	34.70
3	2688.00	47.40 AV	54.00	-6.60	1.00 V	153	12.70	34.70
4	4924.00	46.50 PK	74.00	-27.50	1.00 V	181	5.10	41.40
5	7386.00	58.00 PK	74.00	-16.00	1.23 V	227	12.80	45.20
5	7386.00	46.60 AV	54.00	-7.40	1.23 V	227	1.40	45.20
6	9848.00	57.10 PK	74.00	-16.90	1.24 V	291	12.20	44.80
6	9848.00	44.40 AV	54.00	-9.60	1.24 V	291	-0.40	44.80

- REMARKS:**
1. Emission level(dBuV/m)=Raw Value(dBuV) + Correction Factor(dB)
  2. Correction Factor(dB/m) = Antenna Factor (dB/m) + Cable Factor (dB)
  3. The other emission levels were very low against the limit.
  4. Margin value = Emission level – Limit value.
  5. “ \* “ : Fundamental frequency.



4.2.9 TEST RESULTS (FOR OFDM)

<b>EUT</b>	802.11g High-Speed Ethernet to Wireless Bridge	<b>MODEL</b>	DWL-G810 DWL-G800AP
<b>CHANNEL</b>	Channel 1	<b>FREQUENCY RANGE</b>	Above 1000MHz
<b>INPUT POWER (SYSTEM)</b>	120Vac, 60 Hz		
<b>ENVIRONMENTAL CONDITIONS</b>	30deg. C, 60%RH, 991hPa	<b>DETECTOR FUNCTION</b>	Peak(PK) Average (AV)
<b>TESTED BY:</b> Jamison Chan			

<b>ANTENNA POLARITY &amp; TEST DISTANCE: HORIZONTAL AT 3 M</b>								
No.	Freq. (MHz)	Emission Level (dBuV/m)	Limit (dBuV/m)	Margin (dB)	Antenna Height (m)	Table Angle (Degree)	Raw Value (dBuV)	Correction Factor (dB/m)
1	2390.00	61.40 PK	74.00	-12.60	1.25 H	142	27.80	33.60
1	2390.00	51.70 AV	54.00	-2.30	1.25 H	142	18.10	33.60
2	*2412.00	104.50 PK			1.25 H	142	70.80	33.70
2	*2412.00	94.80 AV			1.25 H	142	61.20	33.70
3	2688.00	61.70 PK	74.00	-12.30	1.25 H	142	27.00	34.70
<b>3</b>	<b>2688.00</b>	<b>52.00 AV</b>	<b>54.00</b>	<b>-2.00</b>	<b>1.25 H</b>	<b>142</b>	<b>17.30</b>	<b>34.70</b>

<b>ANTENNA POLARITY &amp; TEST DISTANCE: VERTICAL AT 3 M</b>								
No.	Freq. (MHz)	Emission Level (dBuV/m)	Limit (dBuV/m)	Margin (dB)	Antenna Height (m)	Table Angle (Degree)	Raw Value (dBuV)	Correction Factor (dB/m)
1	2390.00	57.20 PK	74.00	-16.80	1.46 V	249	23.60	33.60
1	2390.00	48.00 AV	54.00	-6.00	1.46 V	249	14.40	33.60
2	*2412.00	107.50 PK			1.46 V	249	73.80	33.70
2	*2412.00	98.30 AV			1.46 V	249	64.70	33.70
3	2688.00	54.80 PK	74.00	-19.20	1.46 V	249	20.10	34.70
3	2688.00	45.60 AV	54.00	-8.40	1.46 V	249	10.90	34.70
4	4824.00	51.50 PK	74.00	-22.50	1.34 V	235	10.40	41.10
4	4824.00	39.70 AV	54.00	-14.30	1.34 V	235	-1.40	41.10
5	7236.00	55.80 PK	74.00	-18.20	1.44 V	232	11.00	44.80
5	7236.00	42.80 AV	54.00	-11.20	1.44 V	232	-2.00	44.80

- REMARKS:**
1. Emission level(dBuV/m)=Raw Value(dBuV) + Correction Factor(dB)
  2. Correction Factor(dB/m) = Antenna Factor (dB/m) + Cable Factor (dB)
  3. The other emission levels were very low against the limit.
  4. Margin value = Emission level – Limit value.
  5. “ \* “ : Fundamental frequency.



<b>EUT</b>	802.11g High-Speed Ethernet to Wireless Bridge	<b>MODEL</b>	DWL-G810 DWL-G800AP
<b>CHANNEL</b>	Channel 6	<b>FREQUENCY RANGE</b>	Above 1000MHz
<b>INPUT POWER (SYSTEM)</b>	120Vac, 60 Hz		
<b>ENVIRONMENTAL CONDITIONS</b>	30deg. C, 60%RH, 991hPa	<b>DETECTOR FUNCTION</b>	Peak(PK) Average (AV)
<b>TESTED BY:</b> Jamison Chan			

<b>ANTENNA POLARITY &amp; TEST DISTANCE: HORIZONTAL AT 3M</b>								
No.	Freq. (MHz)	Emission Level (dBuV/m)	Limit (dBuV/m)	Margin (dB)	Antenna Height (m)	Table Angle (Degree)	Raw Value (dBuV)	Correction Factor (dB/m)
1	*2437.00	103.90 PK			1.30 H	144	70.20	33.80
1	*2437.00	95.10 AV			1.30 H	144	61.30	33.80

<b>ANTENNA POLARITY &amp; TEST DISTANCE: VERTICAL AT 3M</b>								
No.	Freq. (MHz)	Emission Level (dBuV/m)	Limit (dBuV/m)	Margin (dB)	Antenna Height (m)	Table Angle (Degree)	Raw Value (dBuV)	Correction Factor (dB/m)
1	*2437.00	107.90 PK			1.25 V	150	74.20	33.80
1	*2437.00	98.60 AV			1.25 V	150	64.80	33.80
2	4874.00	52.80 PK	74.00	-21.20	1.44 V	195	11.60	41.30
2	4874.00	40.00 AV	54.00	-14.00	1.44 V	195	-1.30	41.30
3	7311.00	57.20 PK	74.00	-16.80	1.32 V	135	11.90	45.30
3	7311.00	44.20 AV	54.00	-9.80	1.32 V	135	-1.10	45.30

- REMARKS:**
1. Emission level(dBuV/m)=Raw Value(dBuV) + Correction Factor(dB)
  2. Correction Factor(dB/m) = Antenna Factor (dB/m) + Cable Factor (dB)
  3. The other emission levels were very low against the limit.
  4. Margin value = Emission level – Limit value.
  5. “ \* “ : Fundamental frequency.



<b>EUT</b>	802.11g High-Speed Ethernet to Wireless Bridge	<b>MODEL</b>	DWL-G810 DWL-G800AP
<b>CHANNEL</b>	Channel 11	<b>FREQUENCY RANGE</b>	Above 1000MHz
<b>INPUT POWER (SYSTEM)</b>	120Vac, 60 Hz		
<b>ENVIRONMENTAL CONDITIONS</b>	30deg. C, 60%RH, 991hPa	<b>DETECTOR FUNCTION</b>	Peak(PK) Average (AV)
<b>TESTED BY:</b> Jamison Chan			

<b>ANTENNA POLARITY &amp; TEST DISTANCE: HORIZONTAL AT 3M</b>								
No.	Freq. (MHz)	Emission Level (dBuV/m)	Limit (dBuV/m)	Margin (dB)	Antenna Height (m)	Table Angle (Degree)	Raw Value (dBuV)	Correction Factor (dB/m)
1	*2462.00	102.70 PK			1.29 H	145	68.80	33.90
1	*2462.00	93.70 AV			1.29 H	145	59.80	33.90
2	2483.50	60.90 PK	74.00	-13.10	1.29 H	145	27.00	33.90
2	2483.50	51.90 AV	54.00	-2.10	1.29 H	145	18.00	33.90

<b>ANTENNA POLARITY &amp; TEST DISTANCE: VERTICAL AT 3M</b>								
No.	Freq. (MHz)	Emission Level (dBuV/m)	Limit (dBuV/m)	Margin (dB)	Antenna Height (m)	Table Angle (Degree)	Raw Value (dBuV)	Correction Factor (dB/m)
1	2462.00	107.40 PK			1.41 V	250	73.50	33.90
1	2462.00	97.90 AV			1.41 V	250	64.00	33.90
2	2483.50	54.60 PK	74.00	-19.40	1.41 V	250	20.70	33.90
2	2483.50	45.10 AV	54.00	-8.90	1.41 V	250	11.20	33.90
3	2688.00	56.70 PK	74.00	-17.30	1.41 V	250	22.00	34.70
3	2688.00	47.20 AV	54.00	-6.80	1.41 V	250	12.50	34.70
4	4924.00	53.30 PK	74.00	-20.70	1.29 V	184	11.90	41.40
4	4924.00	40.60 AV	54.00	-13.40	1.29 V	184	-0.80	41.40
5	7386.00	57.30 PK	74.00	-16.70	1.30 V	161	12.10	45.20
5	7386.00	44.30 AV	54.00	-9.70	1.30 V	161	-0.90	45.20

- REMARKS:**
1. Emission level(dBuV/m)=Raw Value(dBuV) + Correction Factor(dB)
  2. Correction Factor(dB/m) = Antenna Factor (dB/m) + Cable Factor (dB)
  3. The other emission levels were very low against the limit.
  4. Margin value = Emission level – Limit value.
  5. " \* " : Fundamental frequency.



### 4.3 6dB BANDWIDTH MEASUREMENT

#### 4.3.1 LIMITS OF 6dB BANDWIDTH MEASUREMENT

The minimum of 6dB Bandwidth Measurement is 0.5 MHz.

#### 4.3.2 TEST INSTRUMENTS

Description & Manufacturer	Model No.	Serial No.	Calibrated Until
SPECTRUM ANALYZER	FSEK30	100049	Aug. 12, 2004

**NOTE:** The calibration interval of the above test instruments is 12 months and the calibrations are traceable to NML/ROC and NIST/USA.

#### 4.3.3 TEST PROCEDURE

The transmitter output was connected to the spectrum analyzer through an attenuator. The bandwidth of the fundamental frequency was measured by spectrum analyzer with 100 kHz RBW and 100kHz VBW. The 6dB bandwidth is defined as the total spectrum the power of which is higher than peak power minus 6dB.

#### 4.3.4 DEVIATION FROM TEST STANDARD

No deviation

#### 4.3.5 TEST SETUP

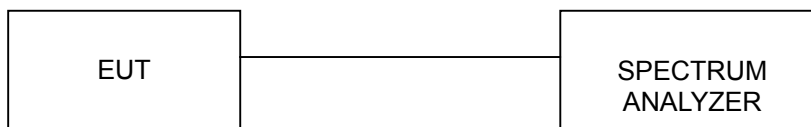

For the actual test configuration, please refer to the related Item – Photographs of the Test Configuration.

#### 4.3.6 EUT OPERATING CONDITIONS

The software provided by client to enable the EUT under transmission condition continuously at lowest, middle and highest channel frequencies individually.



## 4.3.7 TEST RESULTS

<b>EUT</b>	802.11g High-Speed Ethernet to Wireless Bridge	<b>MODEL</b>	DWL-G810 DWL-G800AP
		<b>TEST MODE</b>	CCK
<b>INPUT POWER (SYSTEM)</b>	120Vac, 60 Hz	<b>ENVIRONMENTAL CONDITIONS</b>	26deg. C, 64%RH, 991hPa
<b>TESTED BY:</b> Steven Lu			

<b>CHANNEL</b>	<b>CHANNEL FREQUENCY (MHz)</b>	<b>6dB BANDWIDTH (MHz)</b>	<b>MINIMUM LIMIT (MHz)</b>	<b>PASS/FAIL</b>
1	2412	9.76	0.5	PASS
6	2437	10.04	0.5	PASS
11	2462	10.08	0.5	PASS





CH1

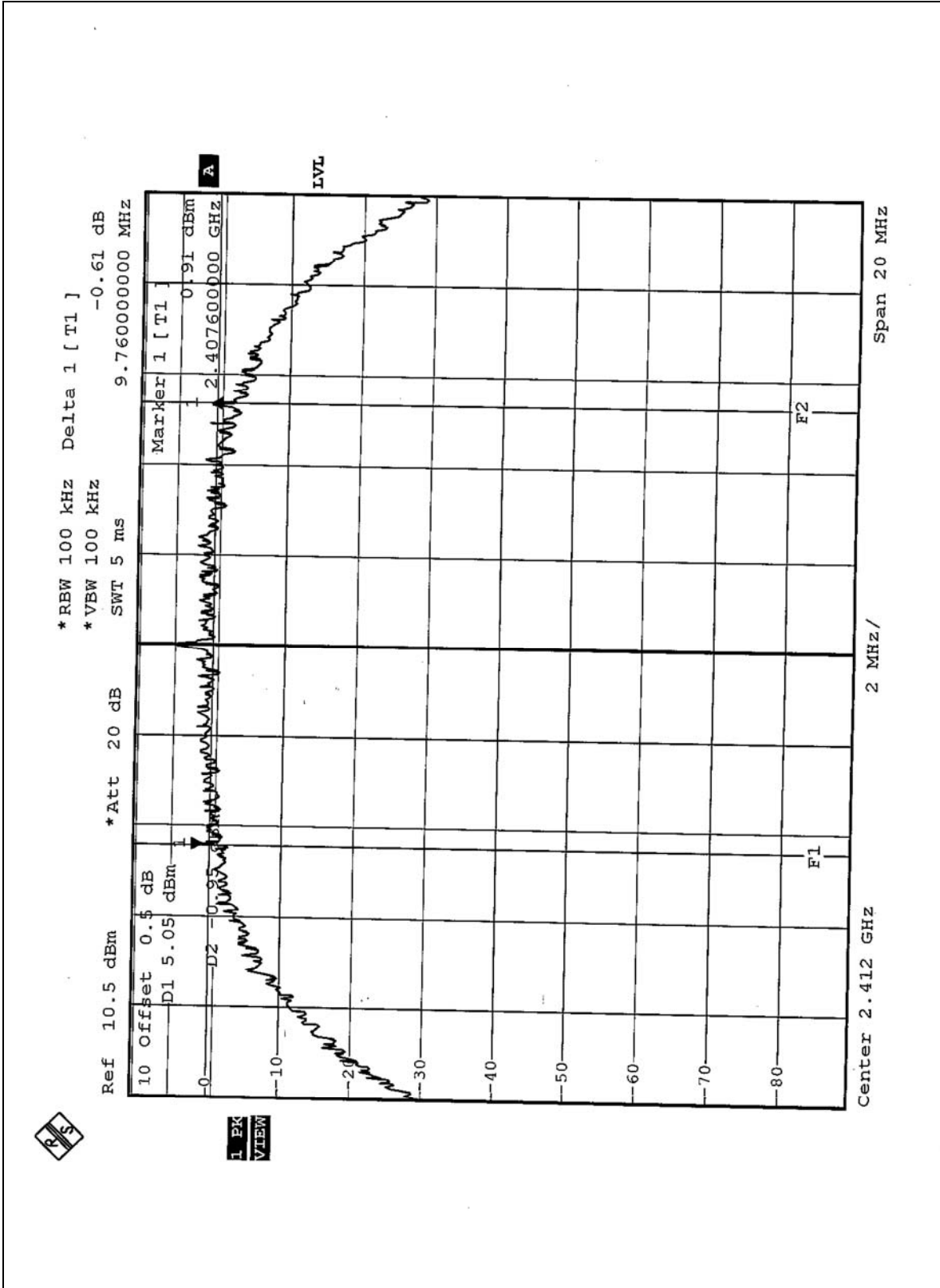



CH6

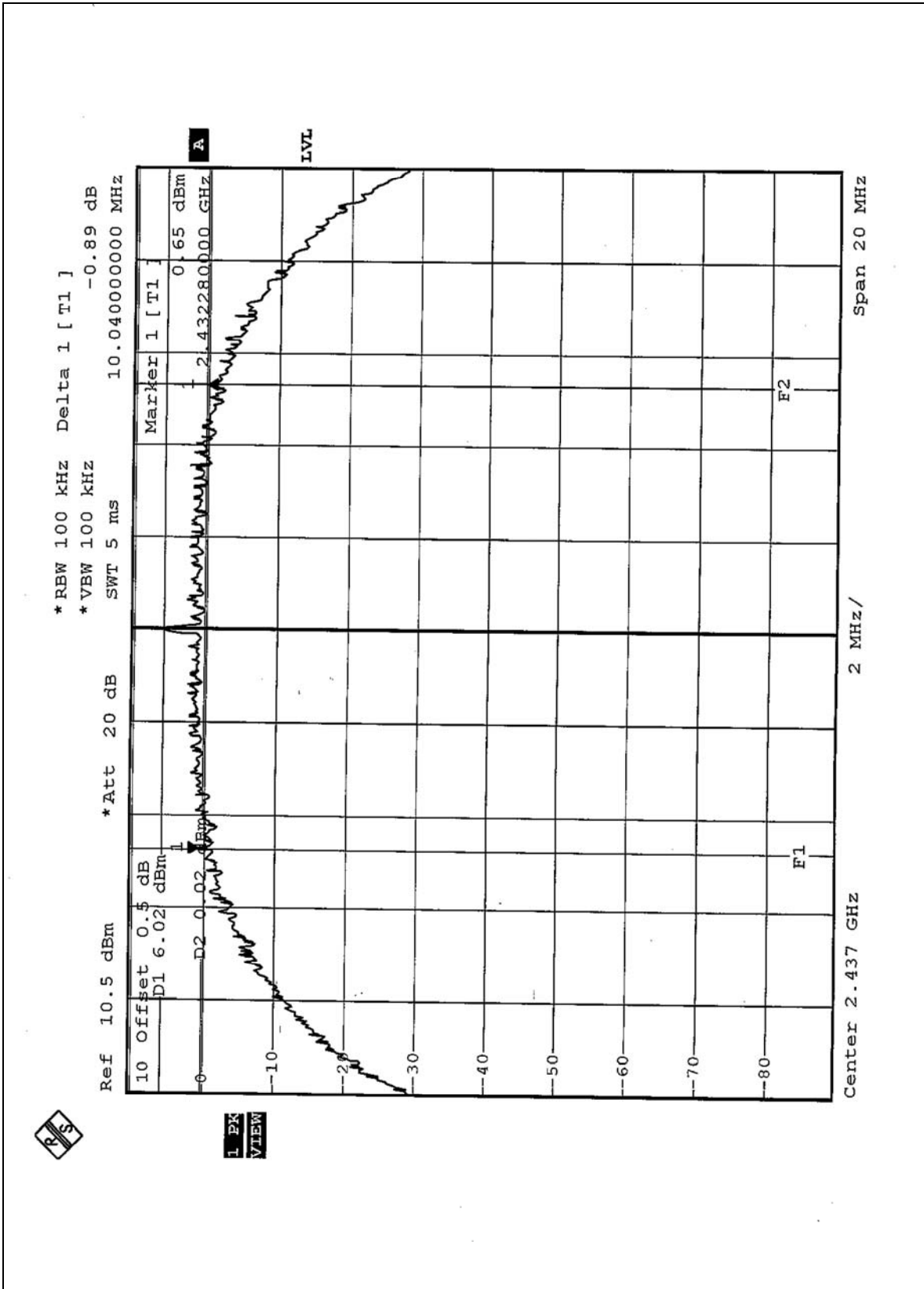



CH11

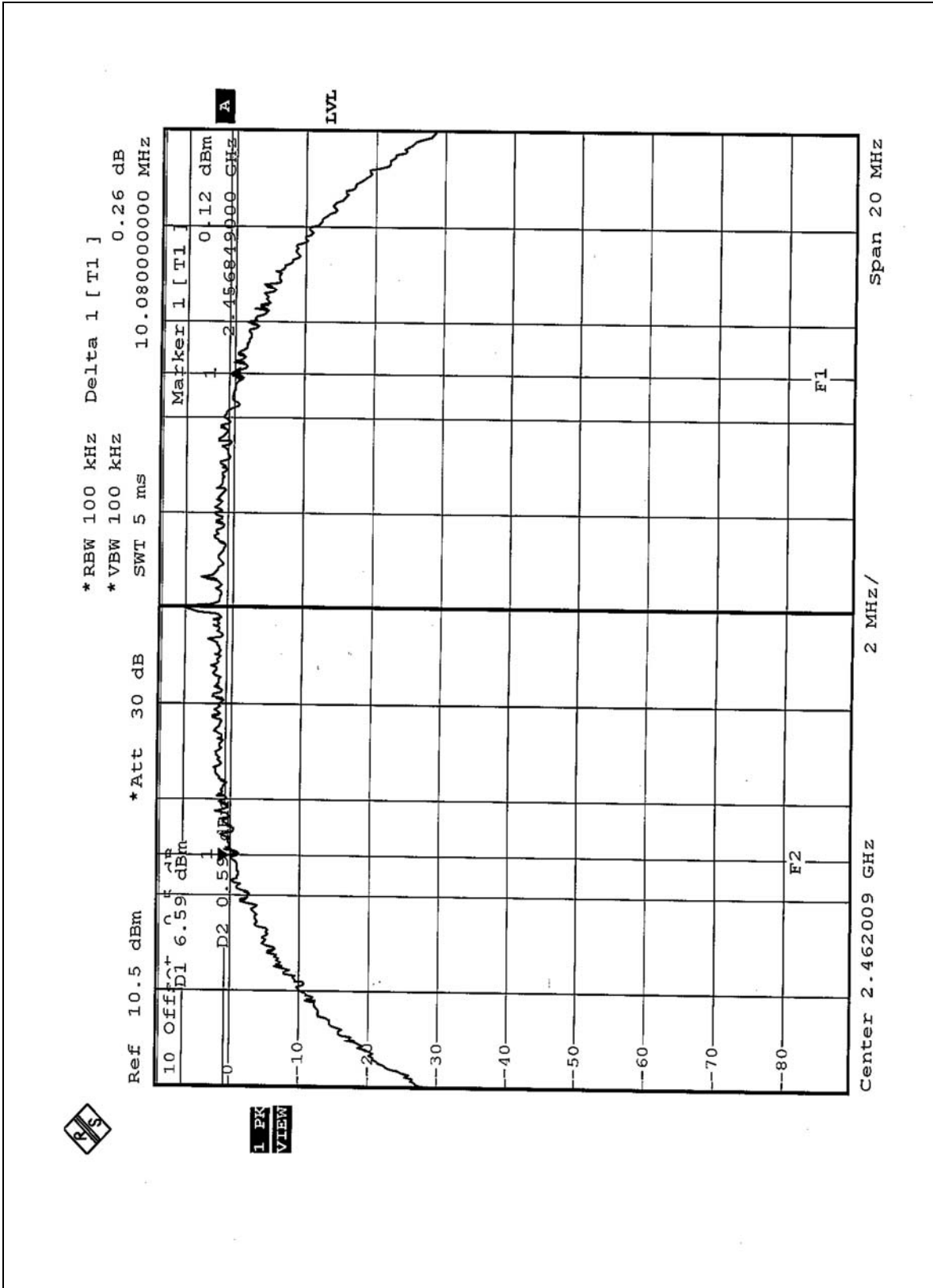



<b>EUT</b>	802.11g High-Speed Ethernet to Wireless Bridge	<b>MODEL</b>	DWL-G810 DWL-G800AP
		<b>TEST MODE</b>	OFDM
<b>INPUT POWER (SYSTEM)</b>	120Vac, 60 Hz	<b>ENVIRONMENTAL CONDITIONS</b>	26deg. C, 64%RH, 991hPa
<b>TESTED BY:</b> Steven Lu			

<b>CHANNEL</b>	<b>CHANNEL FREQUENCY (MHz)</b>	<b>6dB BANDWIDTH (MHz)</b>	<b>MINIMUM LIMIT (MHz)</b>	<b>PASS/FAIL</b>
1	2412	16.36	0.5	PASS
6	2437	16.32	0.5	PASS
11	2462	16.36	0.5	PASS



CH1

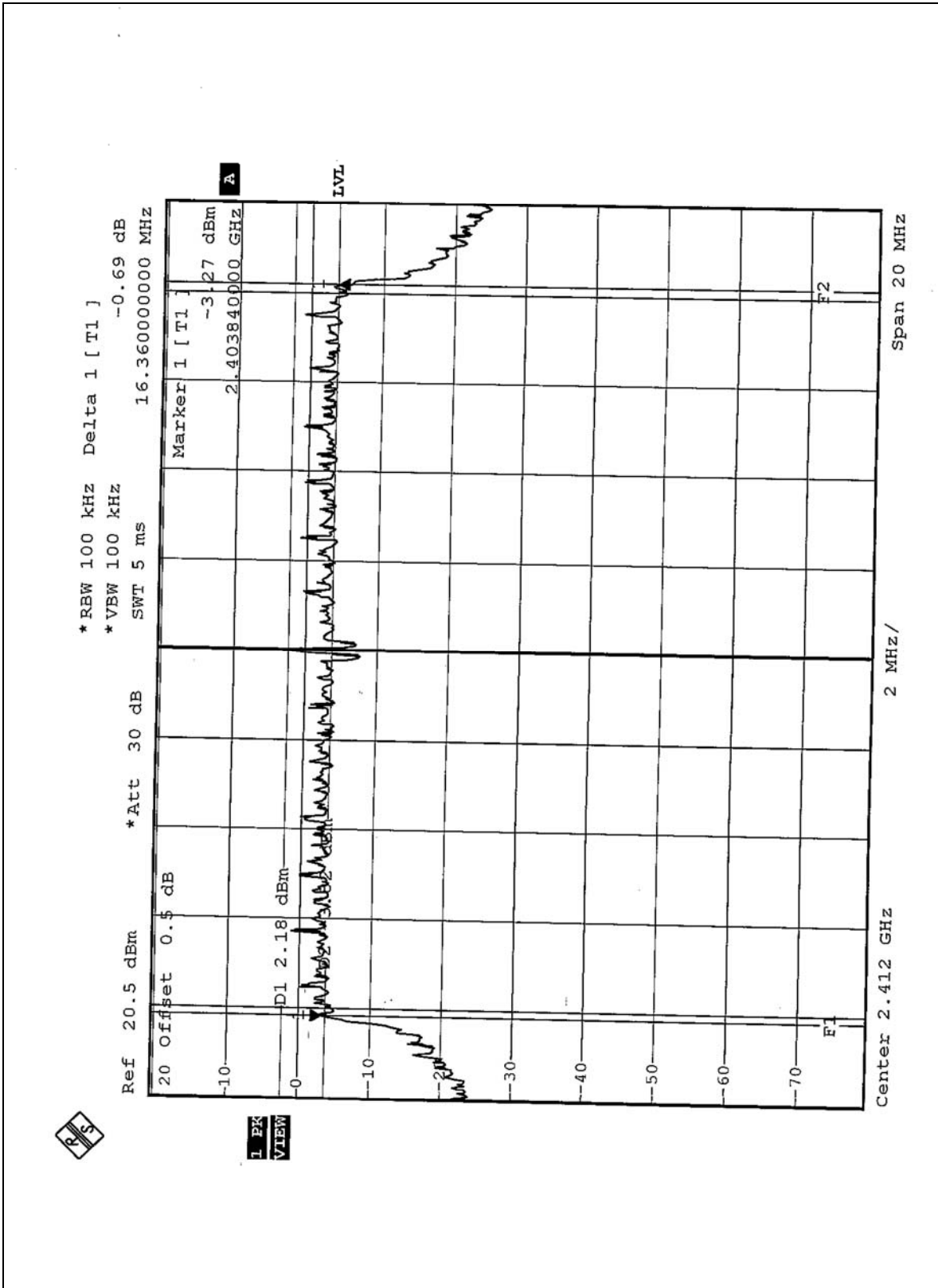



CH6

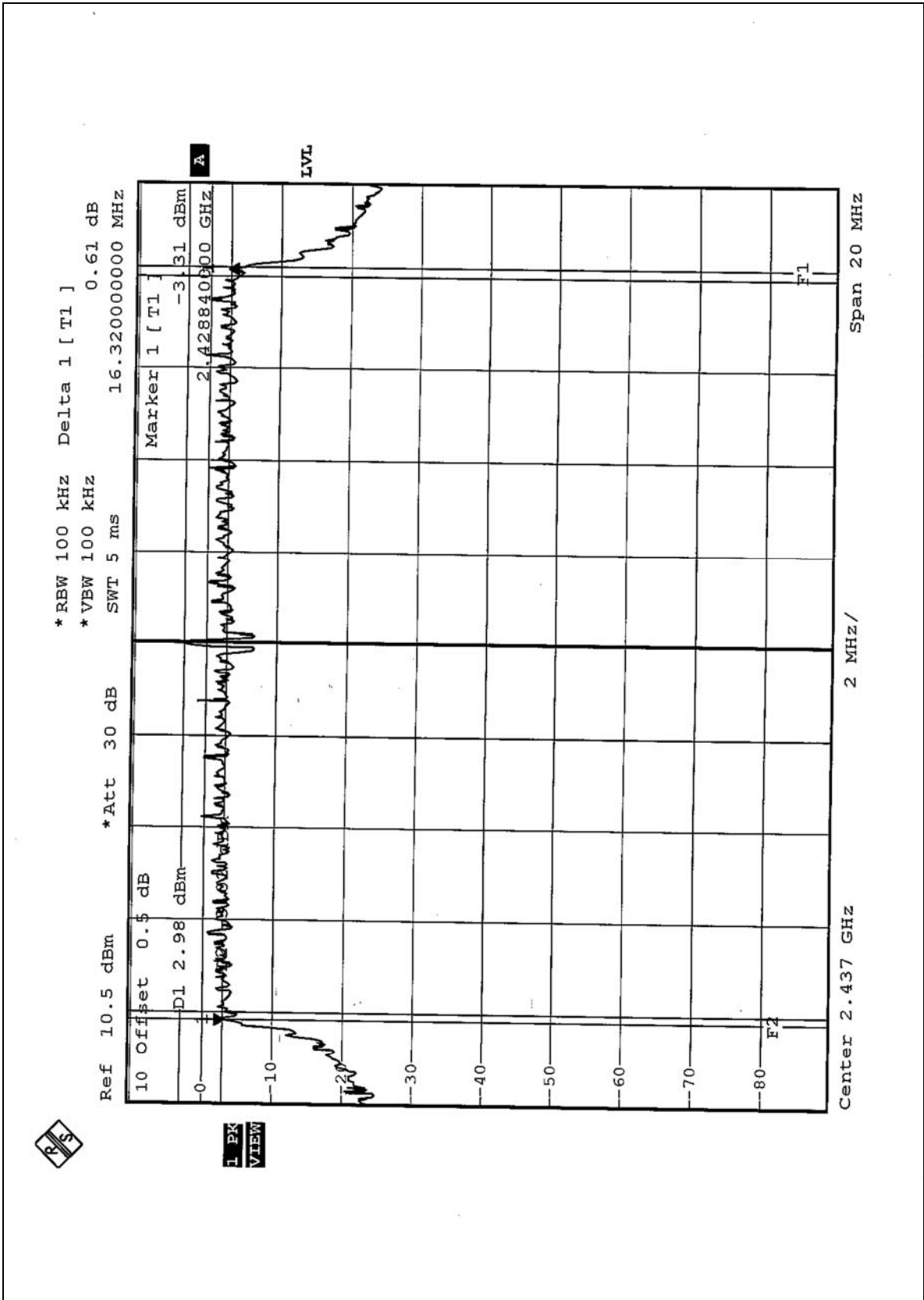



CH11

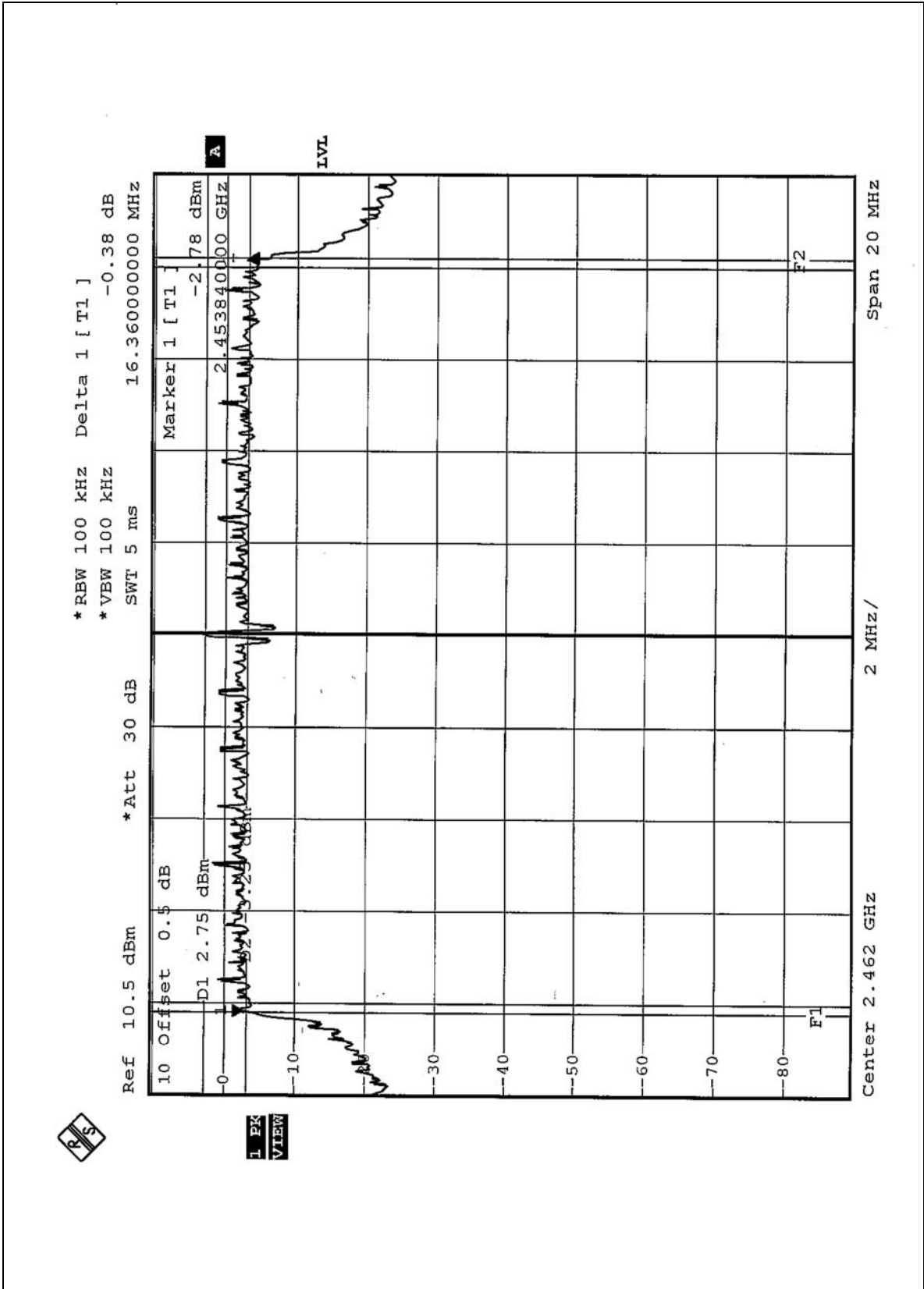



#### 4.4 MAXIMUM PEAK OUTPUT POWER

##### 4.4.1 LIMITS OF MAXIMUM PEAK OUTPUT POWER MEASUREMENT

The Maximum Peak Output Power Measurement is 30dBm.

##### 4.4.2 TEST INSTRUMENTS

Description & Manufacturer	Model No.	Serial No.	Calibrated Until
R&S SPECTRUM ANALYZER	FSEK30	100049	Aug. 12, 2004
R&S SIGNAL GENERATOR	SMP04	100011	May 28, 2004
TEKTRONIX OSCILLOSCOPE	TDS 220	B048470	Mar. 05, 2004
NARDA DETECTOR	4503A	FSCM99899	NA

**NOTE:**

The calibration interval of the above test instruments is 12 months and the calibrations are traceable to NML/ROC and NIST/USA..





#### 4.4.3 TEST PROCEDURES

1. A detector was used on the output port of the EUT. An oscilloscope was used to read the response of the detector.
2. Replaced the EUT by the signal generator. The center frequency of the S.G was adjusted to the center frequency of the measured channel.
3. Adjusted the power to have the same reading on oscilloscope. Record the power level.

#### 4.4.4 DEVIATION FROM TEST STANDARD

No deviation

#### 4.4.5 TEST SETUP



#### 4.4.6 EUT OPERATING CONDITIONS

Same as Item 4.3.6.



4.4.7 TEST RESULTS

<b>EUT</b>	802.11g High-Speed Ethernet to Wireless Bridge	<b>MODEL</b>	DWL-G810 DWL-G800AP
		<b>TEST MODE</b>	CCK
<b>INPUT POWER (SYSTEM)</b>	120Vac, 60 Hz	<b>ENVIRONMENTAL CONDITIONS</b>	26deg. C, 64%RH, 991hPa
<b>TESTED BY:</b> Steven Lu			

CHANNEL	CHANNEL FREQUENCY (MHz)	PEAK POWER OUTPUT (dBm)	PEAK POWER LIMIT (dBm)	PASS/FAIL
1	2412	17.02	30	PASS
6	2437	17.04	30	PASS
11	2462	16.99	30	PASS

<b>EUT</b>	802.11g High-Speed Ethernet to Wireless Bridge	<b>MODEL</b>	DWL-G810 DWL-G800AP
		<b>TEST MODE</b>	OFDM
<b>INPUT POWER (SYSTEM)</b>	120Vac, 60 Hz	<b>ENVIRONMENTAL CONDITIONS</b>	26deg. C, 64%RH, 991hPa
<b>TESTED BY:</b> Steven Lu			

CHANNEL	CHANNEL FREQUENCY (MHz)	PEAK POWER OUTPUT (dBm)	PEAK POWER LIMIT (dBm)	PASS/FAIL
1	2412	17.07	30	PASS
6	2437	17.12	30	PASS
11	2462	16.98	30	PASS



## 4.5 POWER SPECTRAL DENSITY MEASUREMENT

### 4.5.1 LIMITS OF POWER SPECTRAL DENSITY MEASUREMENT

The Maximum of Power Spectral Density Measurement is 8dBm.

### 4.5.2 TEST INSTRUMENTS

Description & Manufacturer	Model No.	Serial No.	Calibrated Until
SPECTRUM ANALYZER	FSEK30	100049	Aug. 12, 2004

**NOTE:** The calibration interval of the above test instruments is 12 months and the calibrations are traceable to NML/ROC and NIST/USA.

#### 4.5.3 TEST PROCEDURE

The transmitter output was connected to the spectrum analyzer through an attenuator, the bandwidth of the fundamental frequency was measured with the spectrum analyzer using 3kHz RBW and 30kHz VBW, set sweep time=span/3kHz. The power spectral density was measured and recorded. The sweep time is allowed to be longer than span/3KHz for a full response of the mixer in the spectrum analyzer.

#### 4.5.4 DEVIATION FROM TEST STANDARD

No deviation

#### 4.5.5 TEST SETUP



#### 4.5.6 EUT OPERATING CONDITIONS

Same as 4.3.6



## 4.5.7 TEST RESULTS

<b>EUT</b>	802.11g High-Speed Ethernet to Wireless Bridge	<b>MODEL</b>	DWL-G810 DWL-G800AP
		<b>TEST MODE</b>	CCK
<b>INPUT POWER (SYSTEM)</b>	120Vac, 60 Hz	<b>ENVIRONMENTAL CONDITIONS</b>	26deg. C, 64%RH, 991hPa
<b>TESTED BY:</b> Steven Lu			

<b>CHANNEL</b>	<b>CHANNEL FREQUENCY (MHz )</b>	<b>RF POWER LEVEL IN 3 kHz BW (dBm)</b>	<b>MAXIMUM LIMIT (dBm)</b>	<b>PASS/FAIL</b>
1	2412	0.46	8	PASS
6	2437	0.84	8	PASS
11	2462	2.00	8	PASS



CH1

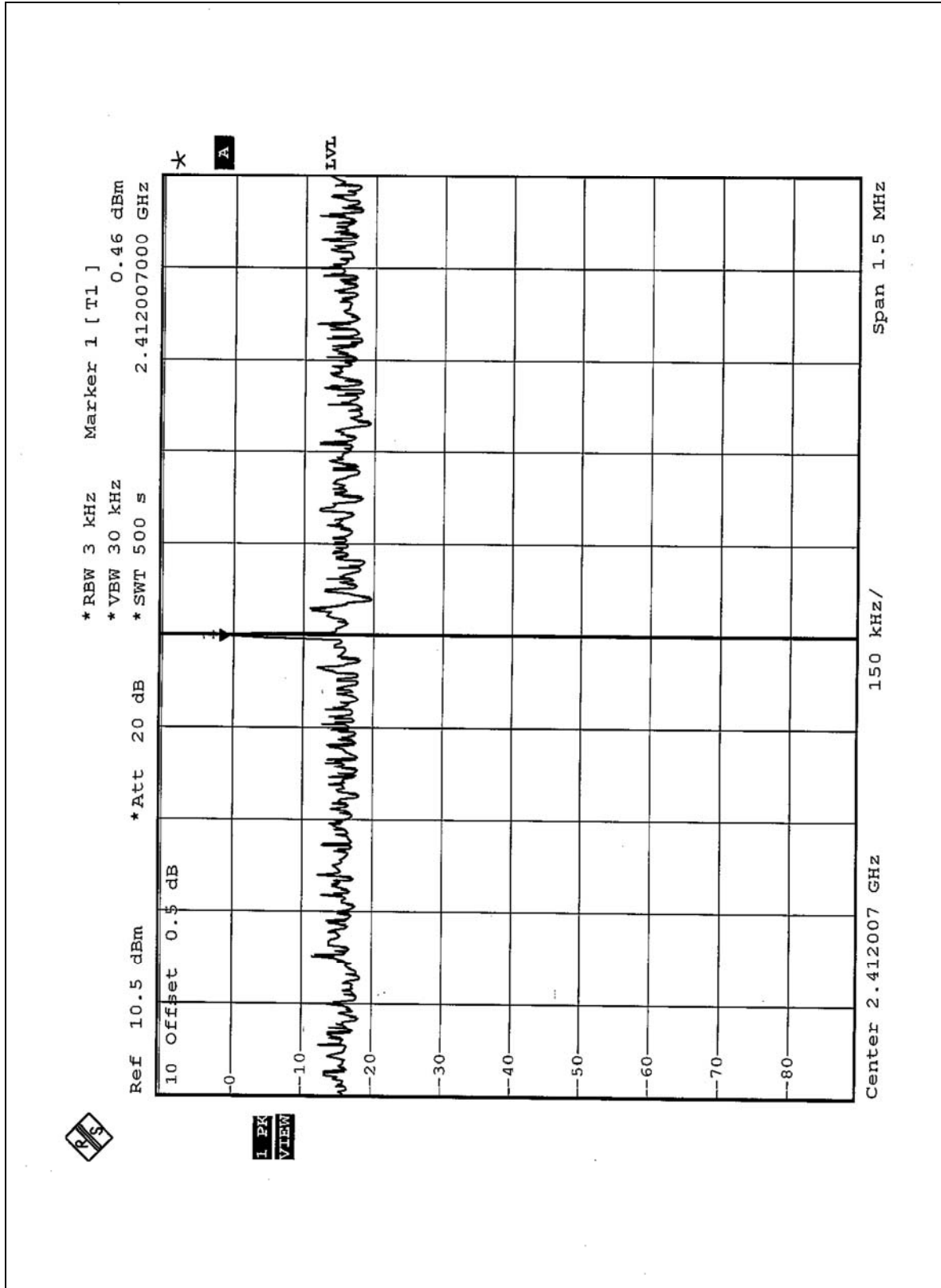



CH6

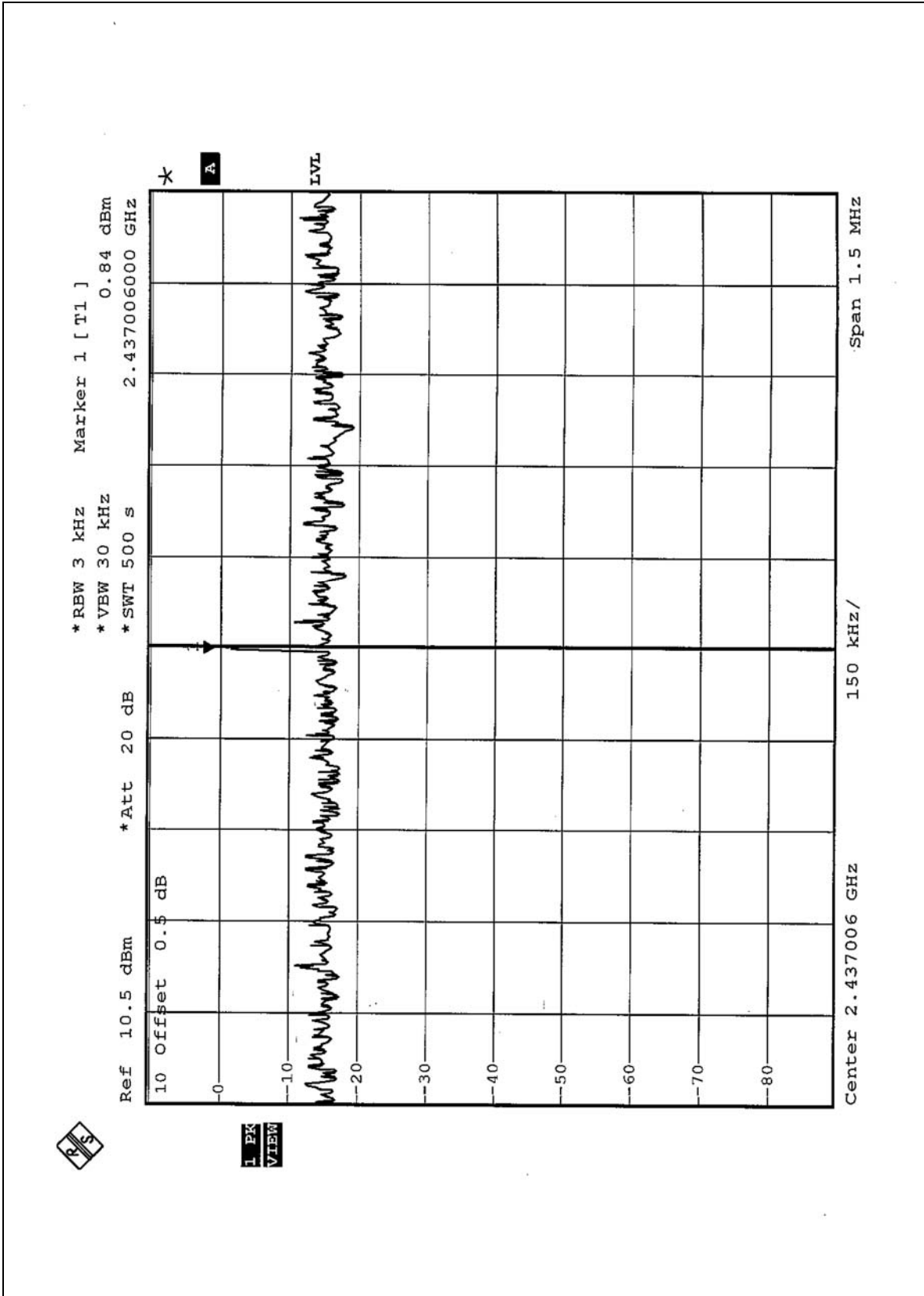



CH11

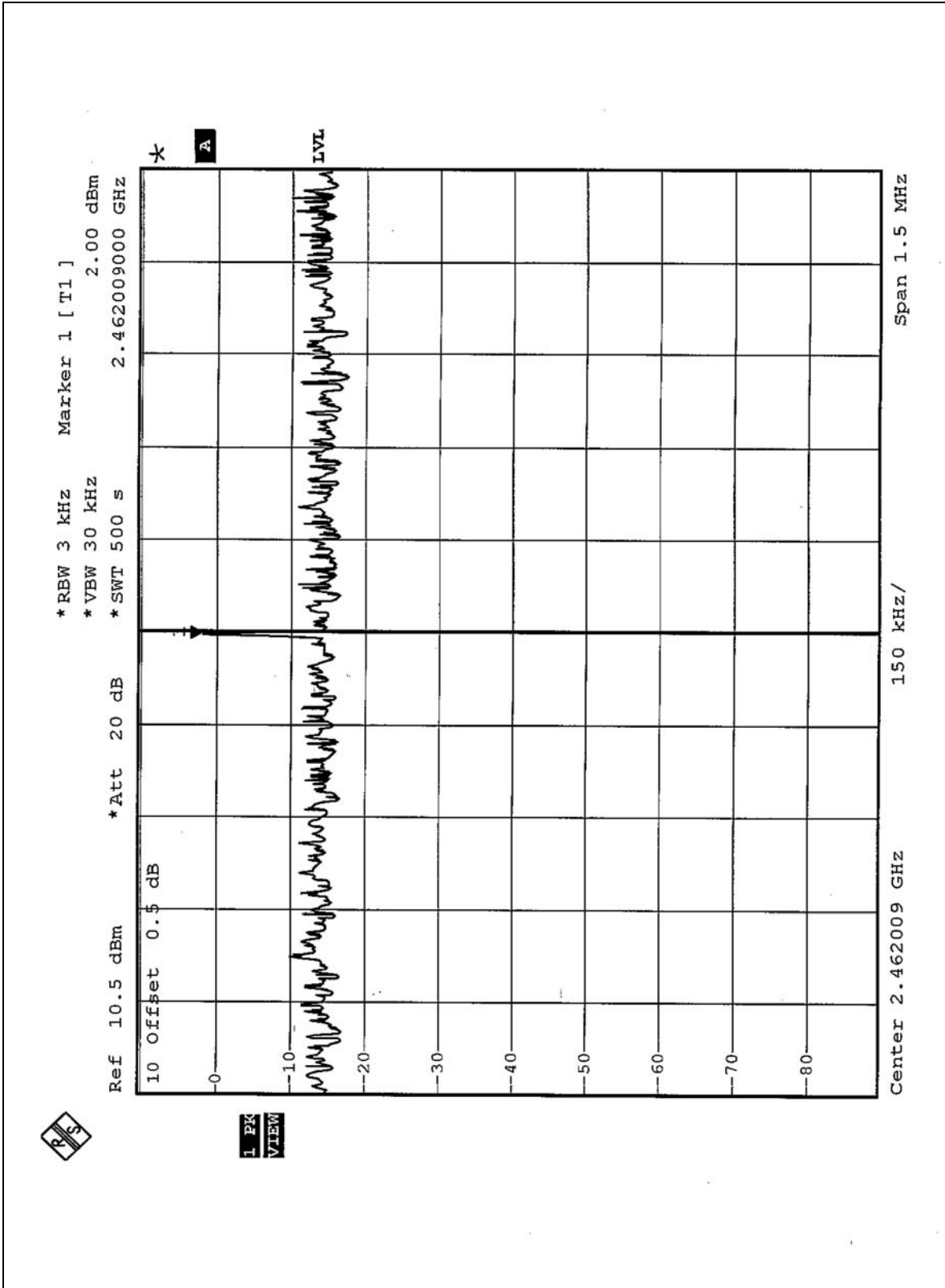





<b>EUT</b>	802.11g High-Speed Ethernet to Wireless Bridge	<b>MODEL</b>	DWL-G810 DWL-G800AP
		<b>TEST MODE</b>	ODFM
<b>INPUT POWER (SYSTEM)</b>	120Vac, 60 Hz	<b>ENVIRONMENTAL CONDITIONS</b>	26deg. C, 64%RH, 991hPa
<b>TESTED BY:</b> Steven Lu			

<b>CHANNEL</b>	<b>CHANNEL FREQUENCY (MHz )</b>	<b>RF POWER LEVEL IN 3 kHz BW (dBm)</b>	<b>MAXIMUM LIMIT (dBm)</b>	<b>PASS/FAIL</b>
1	2412	1.18	8	PASS
6	2437	1.79	8	PASS
11	2462	1.83	8	PASS



CH1

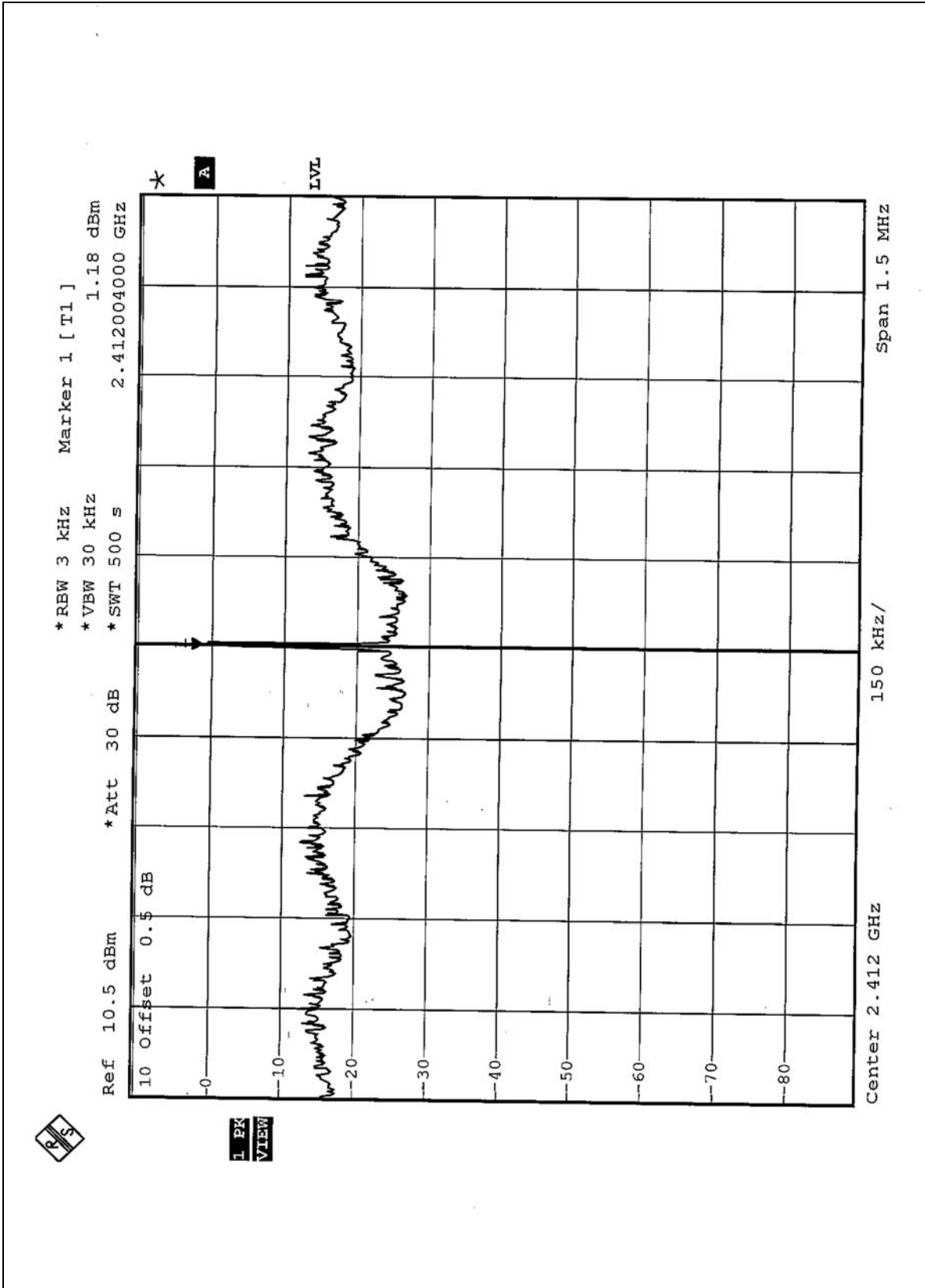



CH6

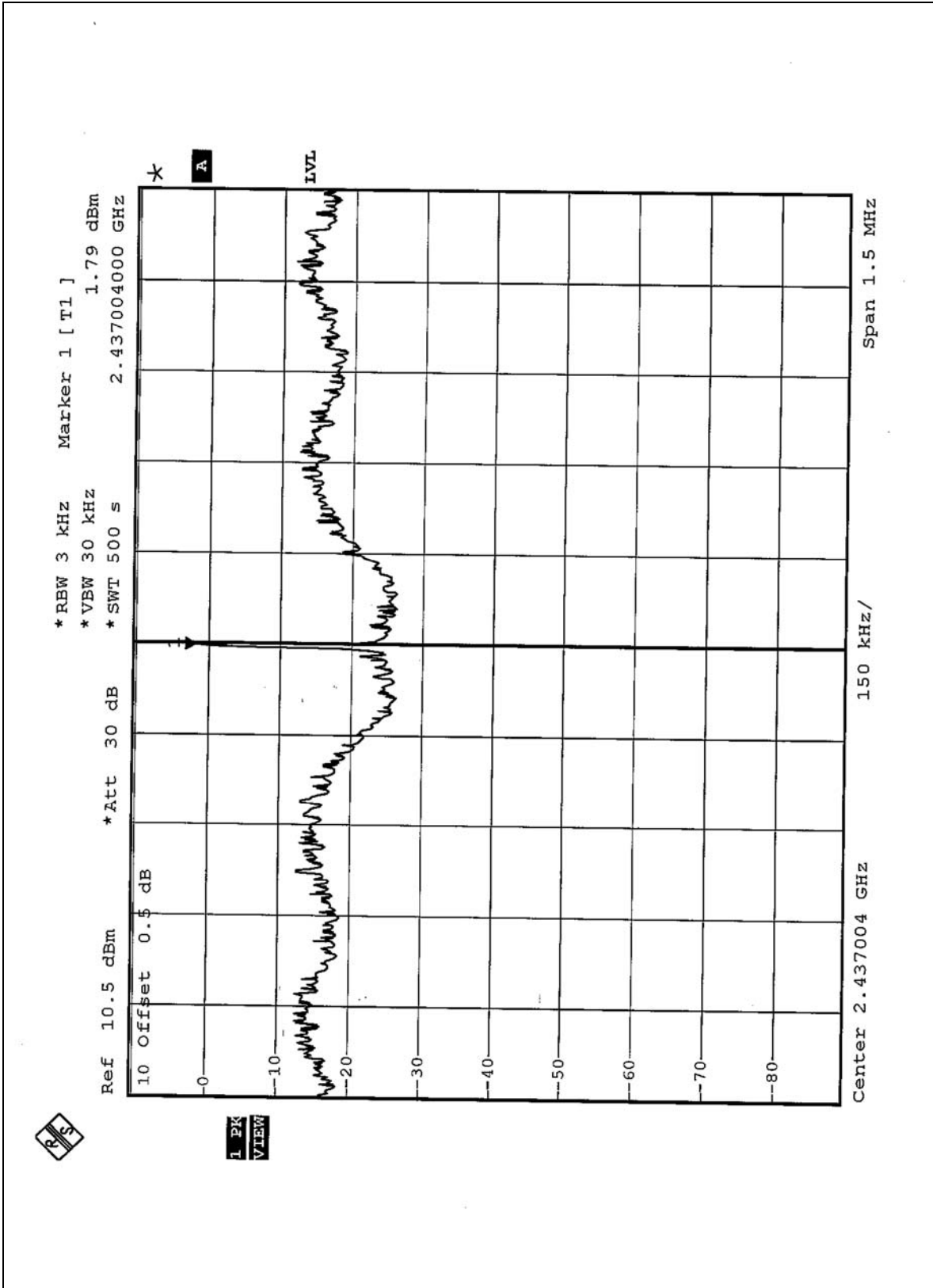



CH11

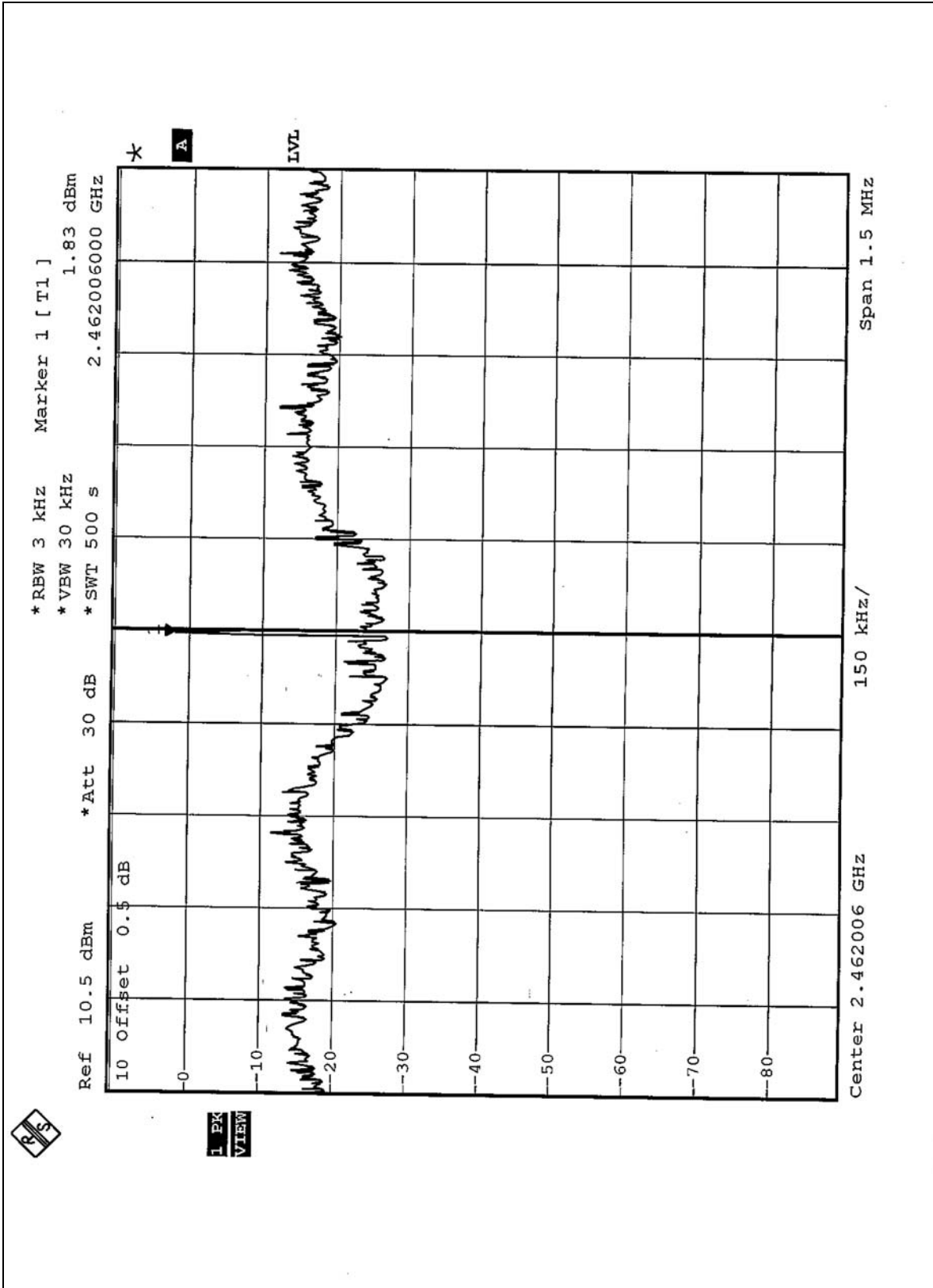



## 4.6 BAND EDGES MEASUREMENT

### 4.6.1 LIMITS OF BAND EDGES MEASUREMENT

Below  $-20\text{dB}$  of the highest emission level of operating band (in 100KHz Resolution Bandwidth).

### 4.6.2 TEST INSTRUMENTS

Description & Manufacturer	Model No.	Serial No.	Calibrated Until
SPECTRUM ANALYZER	FSEK30	100049	Aug. 12, 2004

**NOTE:** The calibration interval of the above test instruments is 12 months and the calibrations are traceable to NML/ROC and NIST/USA.

### 4.6.3 TEST PROCEDURE

The transmitter output was connected to the spectrum analyzer via a low lose cable. Set both RBW and VBW of spectrum analyzer to 100kHz with suitable frequency span including 100MHz bandwidth from band edge. The band edges was measured and recorded.

### 4.6.4 DEVIATION FROM TEST STANDARD

No deviation



#### 4.6.5 EUT OPERATING CONDITION

Same as Item 4.3.6

#### 4.6.6 TEST RESULTS ( FOR CCK)

The spectrum plots are attached on the following 2 pages. D2 line indicates the highest level, D1 line indicates the 20dB offset below D2. It shows compliance with the requirement in part 15.247(C).

**NOTE 1:**

The band edge emission plot on the following first pages shows 51.49dB delta between carrier maximum power and local maximum emission in restrict band (2.3602GHz). The emission of carrier strength list in the test result of channel 1 at the item 4.2.8 is 101.50dBuV/m, so the maximum field strength in restrict band is  $101.50-51.49=50.01$ dBuV/m which is under 54dBuV/m limit.

**NOTE 2:**

The band edge emission plot on the following second pages shows 58.92dB delta between carrier maximum power and local maximum emission in restrict band (2.4841GHz). The emission of carrier strength list in the test result of channel 11 at the item 4.2.8 is 101.70dBuV/m, so the maximum field strength in restrict band is  $101.70-58.92=42.78$ dBuV/m which is under 54 dBuV/m limit.



1 PK VIEW

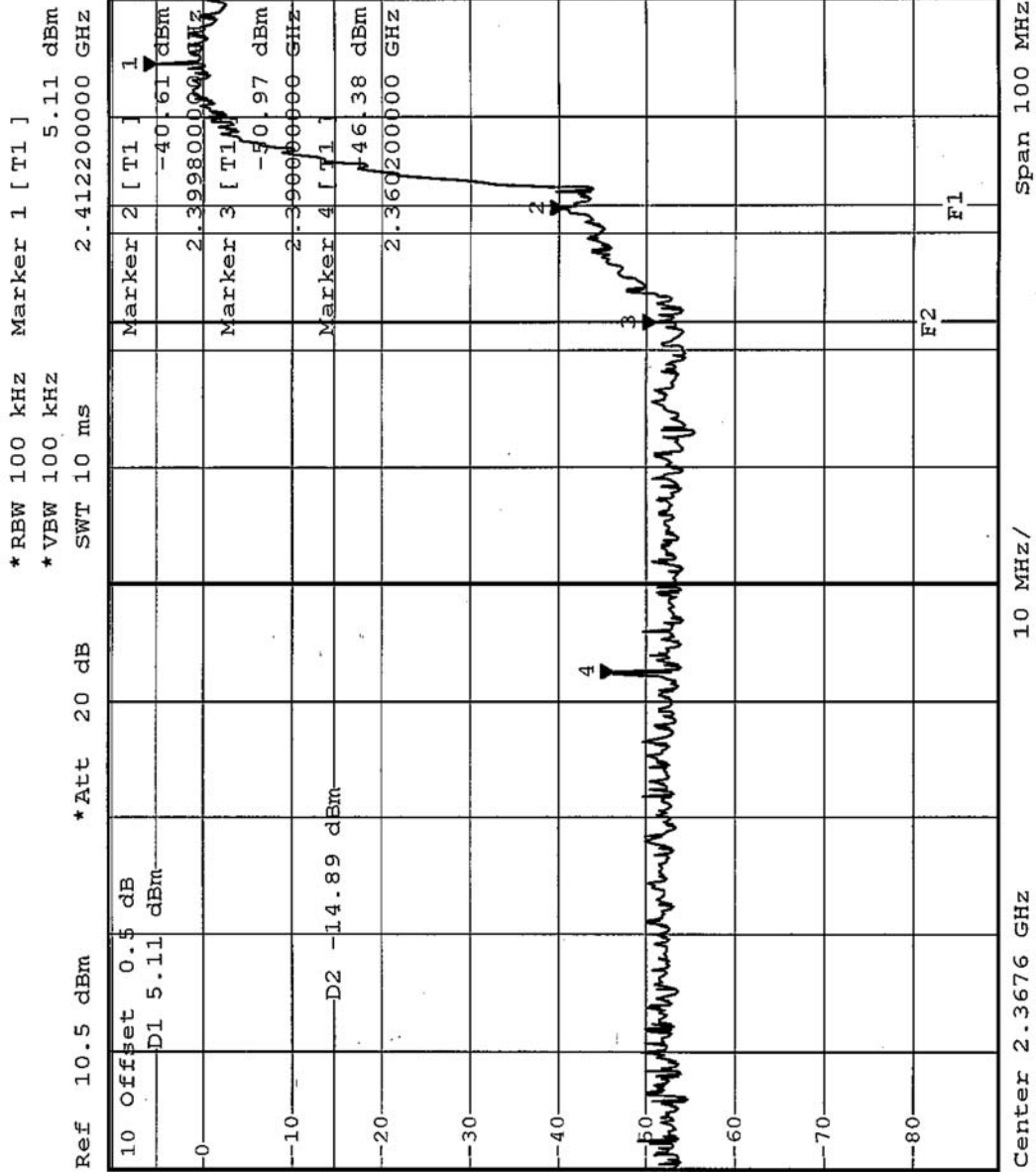

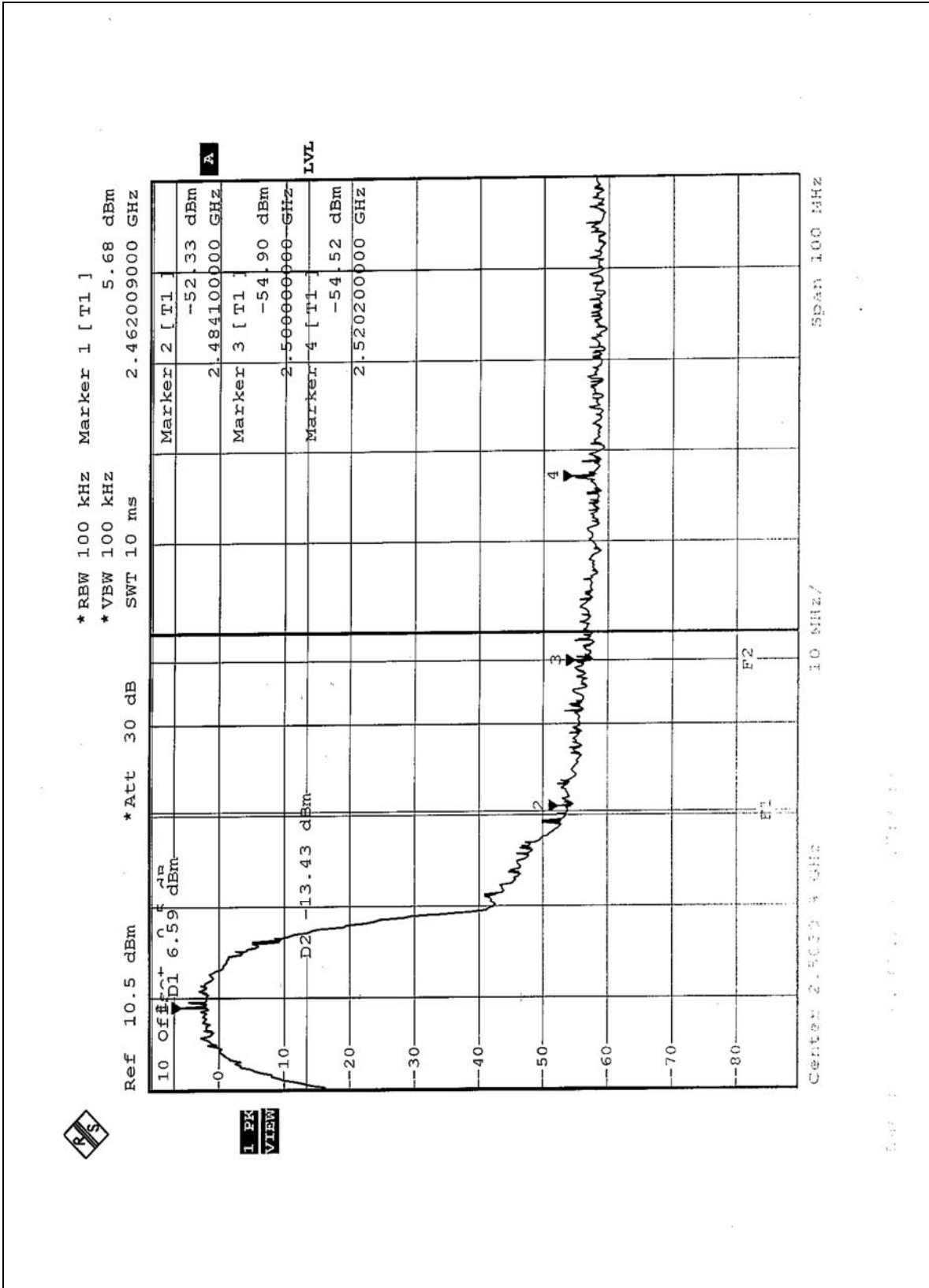





#### 4.6.7 TEST RESULTS ( FOR OFDM)

The spectrum plots are attached on the following 2 pages. D2 line indicates the highest level, D1 line indicates the 20dB offset below D2. It shows compliance with the requirement in part 15.247(C).

**NOTE 1:**

The band edge emission plot on the following first pages shows 47.09dB delta between carrier maximum power and local maximum emission in restrict band (2.3600GHz). The emission of carrier strength list in the test result of channel 1 at the item 4.2.9 is 98.30dBuV/m, so the maximum field strength in restrict band is  $98.30 - 47.09 = 51.21$ dBuV/m which is under 54dBuV/m limit.

**NOTE 2:**

The band edge emission plot on the following second pages shows 51.89dB delta between carrier maximum power and local maximum emission in restrict band (2.4837GHz). The emission of carrier strength list in the test result of channel 11 at the item 4.2.9 is 97.90dBuV/m, so the maximum field strength in restrict band is  $97.90 - 51.89 = 46.01$ dBuV/m which is under 54 dBuV/m limit.

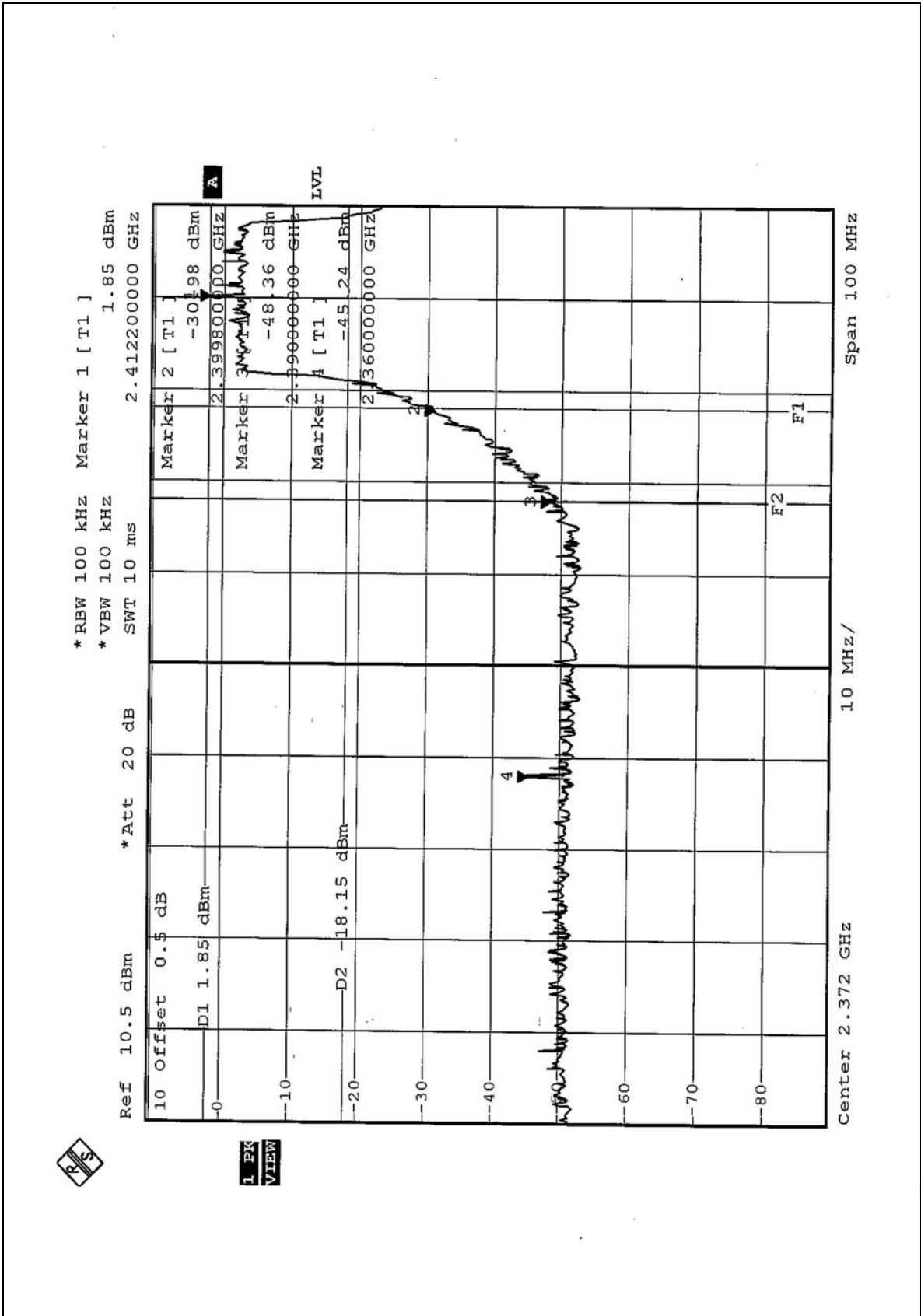

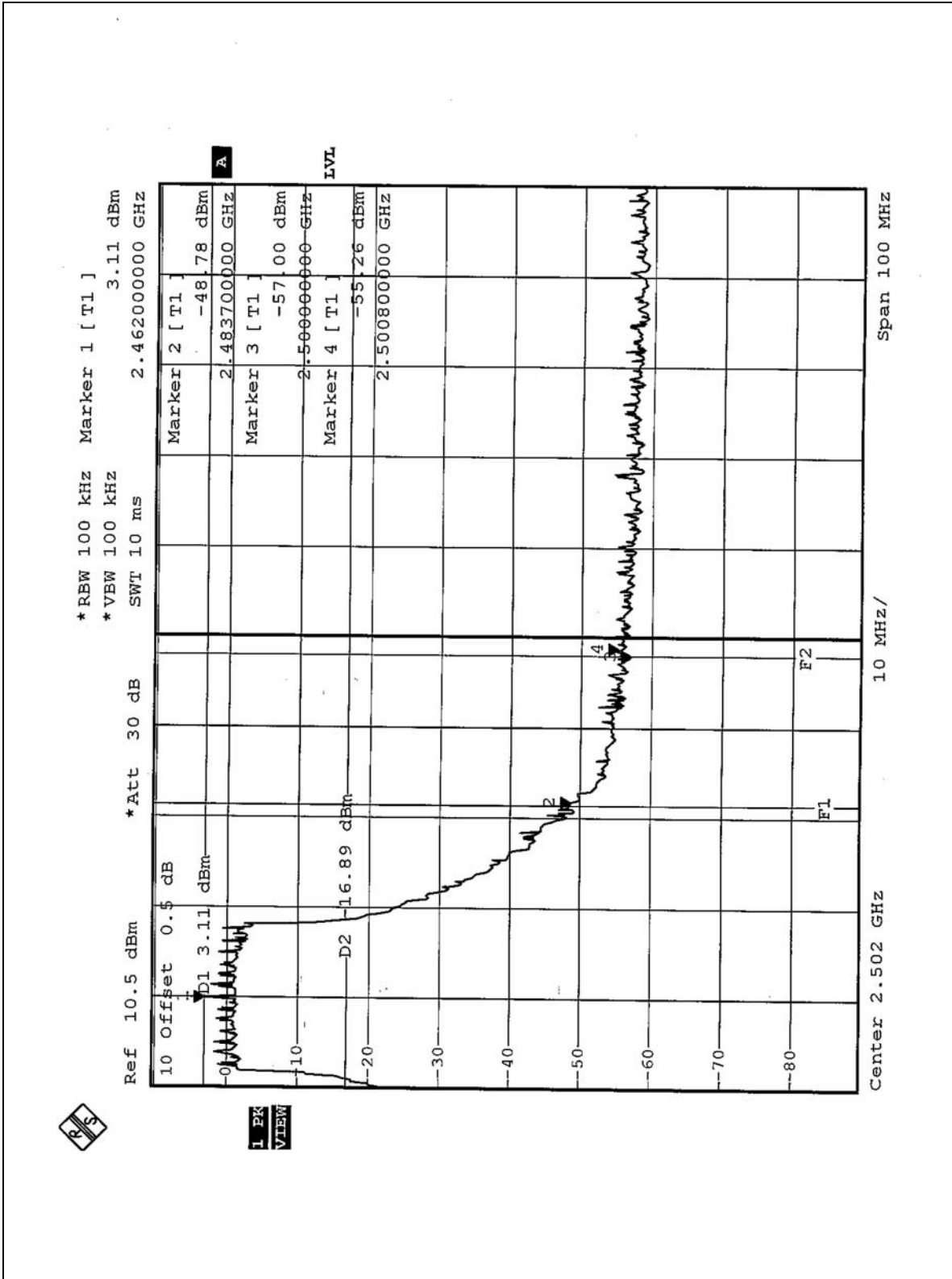



## **4.7 ANTENNA REQUIREMENT**

### **4.7.1 STANDARD APPLICABLE**

For intentional device, according to FCC 47 CFR Section 15.203, an intentional radiator shall be designed to ensure that no antenna other than that furnished by the responsible party shall be used with the device.

And according to FCC 47 CFR Section 15.247 (b), if transmitting antennas of directional gain greater than 6dBi are used, the power shall be reduced by the amount in dB that the directional gain of the antenna exceeds 6dBi.

### **4.7.2 ANTENNA CONNECTED CONSTRUCTION**

The antenna type used in this product is Dipole Antenna without antenna connector. The maximum Gain of this antenna is only 1.8dBi.

## 5 PHOTOGRAPHS OF THE TEST CONFIGURATION

### CONDUCTED EMISSION TEST



### RADIATED EMISSION TEST





## 6 INFORMATION ON THE TESTING LABORATORIES

We, ADT Corp., were founded in 1988 to provide our best service in EMC and Safety consultation. Our laboratories are accredited and approved by the following approval agencies according to ISO/IEC 17025, Guide 25 or EN 45001:

<b>USA</b>	FCC, NVLAP
<b>Germany</b>	TUV Rheinland
<b>Japan</b>	VCCI
<b>New Zealand</b>	MoC
<b>Norway</b>	NEMKO
<b>R.O.C.</b>	BSMI, DGT, CNLA

Copies of accreditation certificates of our laboratories obtained from approval agencies can be downloaded from our web site:

[www.adt.com.tw/index.5/phtml](http://www.adt.com.tw/index.5/phtml).

If you have any comments, please feel free to contact us at the following:

**Lin Kou EMC Lab:**

Tel: 886-2-26052180

Fax: 886-2-26052943

**Hsin Chu EMC Lab:**

Tel: 886-35-935343

Fax: 886-35-935342

**Lin Kou Safety Lab:**

Tel: 886-2-26093195

Fax: 886-2-26093184

**Lin Kou RF&Telecom Lab**

Tel: 886-3-3270910

Fax: 886-3-3270892

**Email:** [service@mail.adt.com.tw](mailto:service@mail.adt.com.tw)

**Web Site:** [www.adt.com.tw](http://www.adt.com.tw)

The address and road map of all our labs can be found in our web site also.